

Higher drawing/s:	10 00 000 A	1:5	Cable chain anchor, simpler holddown	25-09-07	B
			First issue	23-11-06	A
			Description of change	Date (d-m-y)	Rev.
Material:	ASSEMBLY		Title		
			Y-CAR ASSEMBLY		
	Drawing Number		Process	Revision	
	10 30 000		A	B	

**MechMate**  
www.mechmate.com

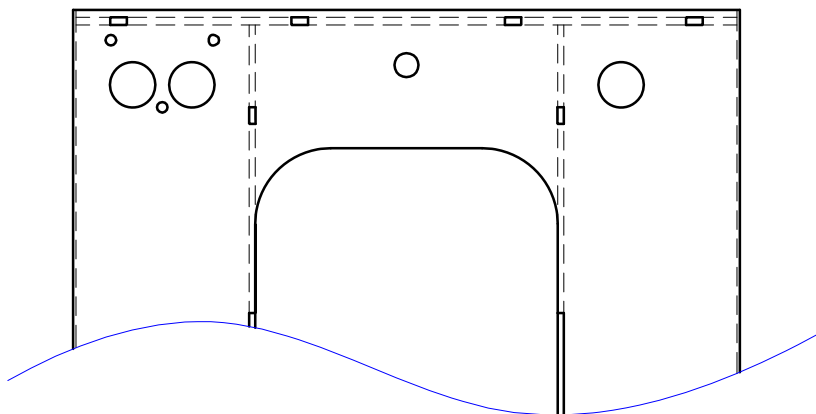
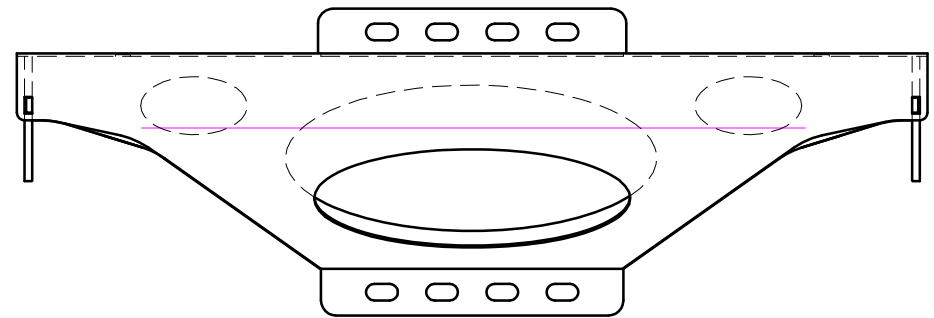
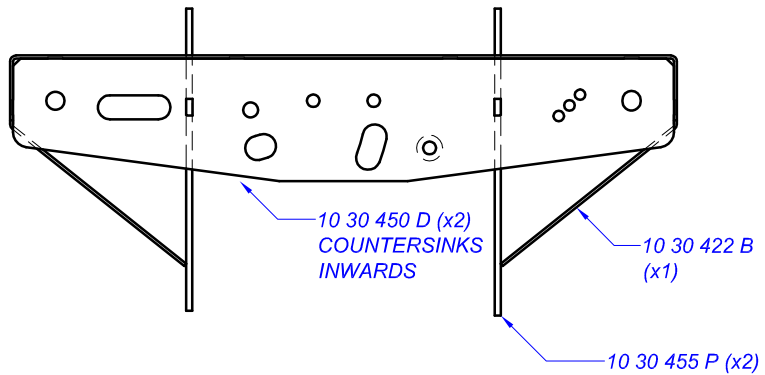

Welding instructions, with photos, are on the Forum

Higher drawing/s:	10 30 000 A	1:5		
			First issue	22-11-06 A
			Description of change	Date (d-m-y) Rev.
Material:	2 to 5mm STEEL		Title	
			Y-CAR FRAME WELDED	
	Drawing Number		Process	Revision
	10 30 420		W	A
	www.mechmate.com			

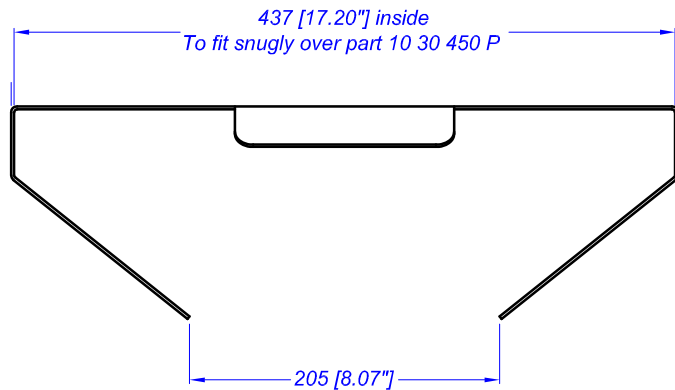
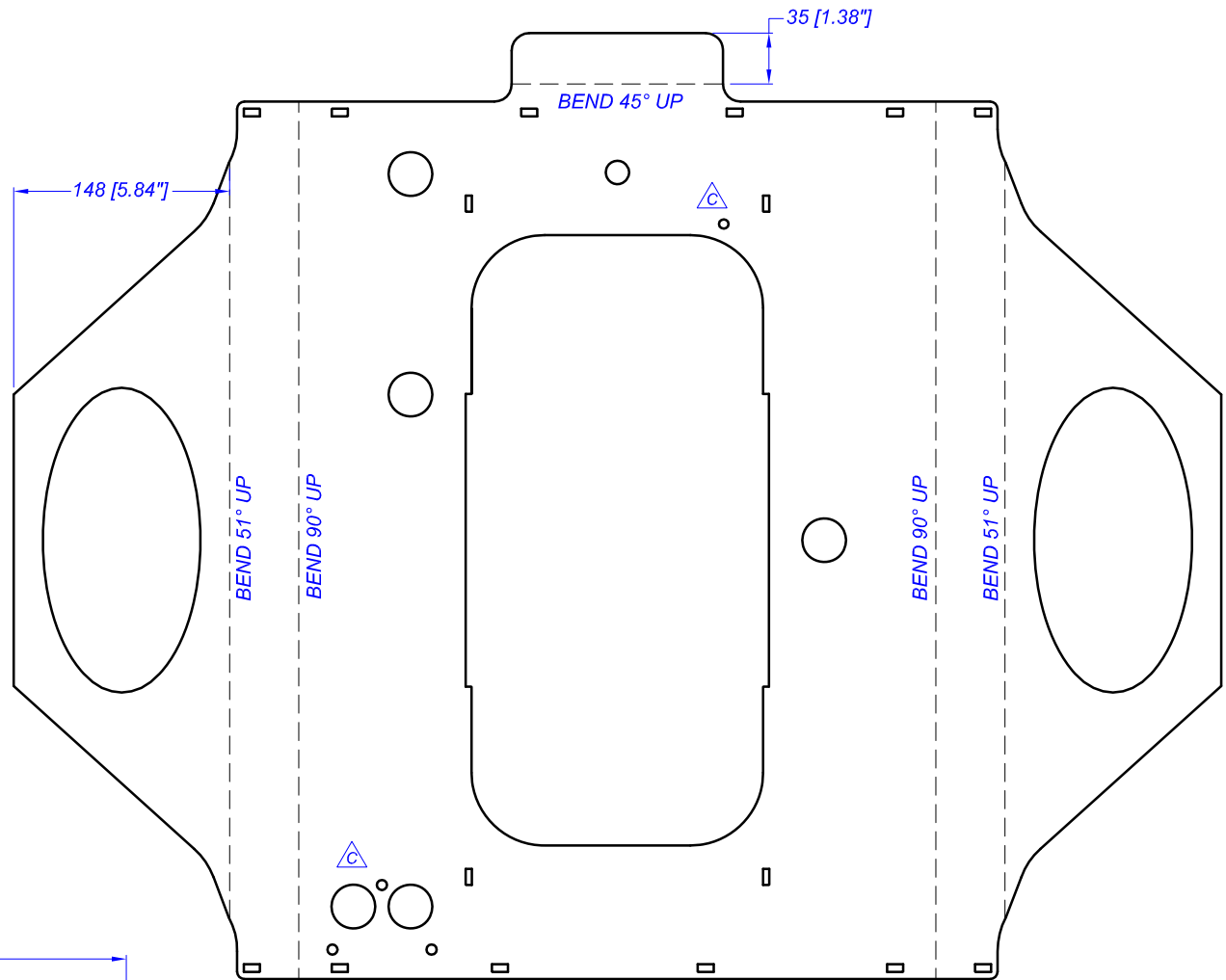

10 30 422 P

Higher drawing/s:	10 20 420 W	1:5	Showing handed part	26-09-07	C
			Added bend (switch box)	08-06-08	D
			Description of change	Date (d-m-y)	Rev.
Material:	2mm STEEL PLATE		Title		
 www.mechmate.com			CAR MAIN PLATE - BENT		
			Drawing Number <b>10 30 422</b>	Process <b>B</b>	Revision <b>D</b>

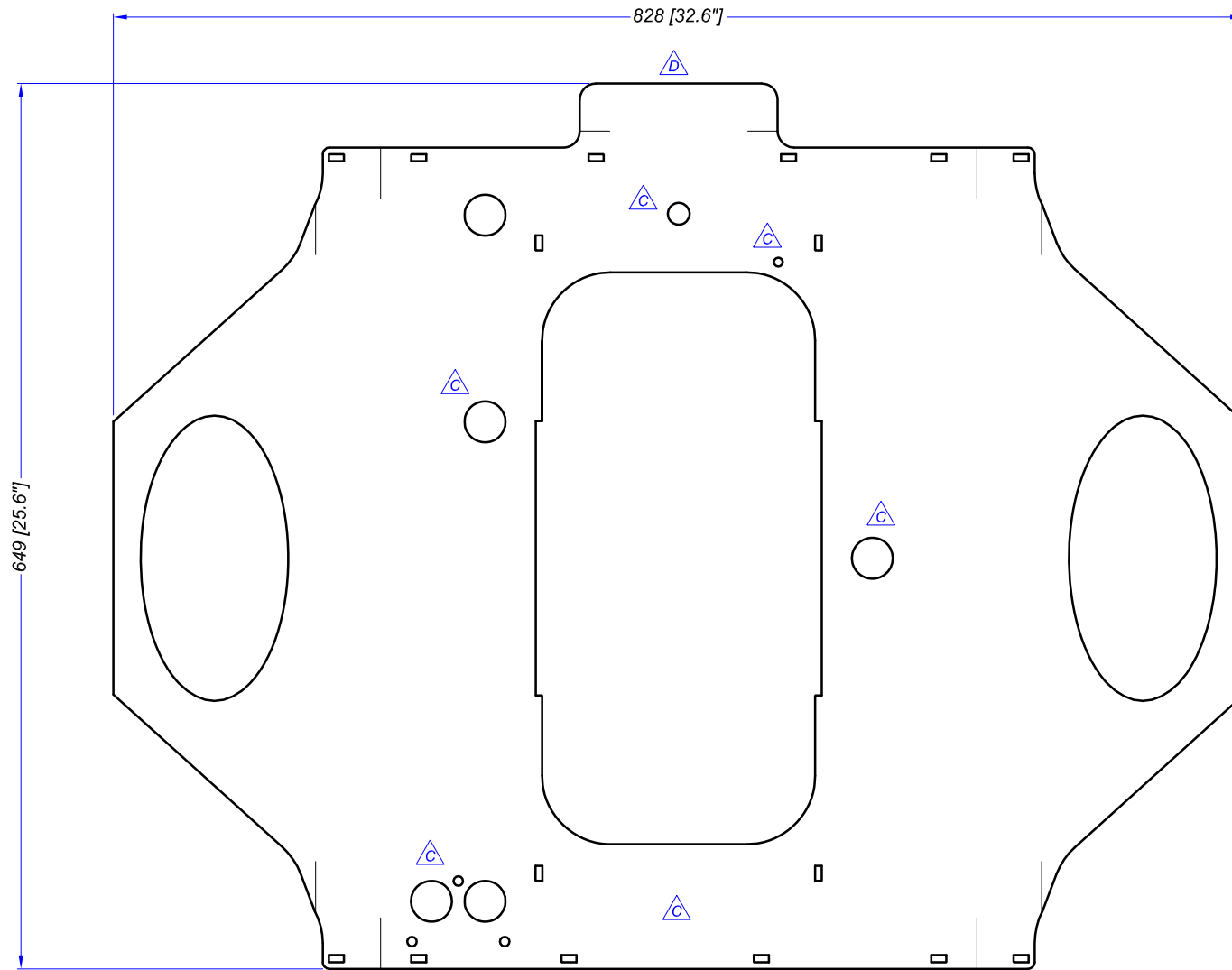



SUPPLY .dxf VERSION OF THIS DRAWING TO THE LASER CUTTING CONTRACTOR.

ENGRAVE BEND MARKS

Higher drawing/s:	10 20 422 B	1:5	Revised holes - part now handed	26-09-07	C
			Added bent lip for mounting switch station	08-06-08	D
			Description of change	Date (d-m-y)	Rev.
Material:	2mm (14ga) STEEL PLATE		Title		
			CAR MAIN PLATE - PROFILE CUT		
Drawing Number		Process	Revision		
10 30 422		P	D		

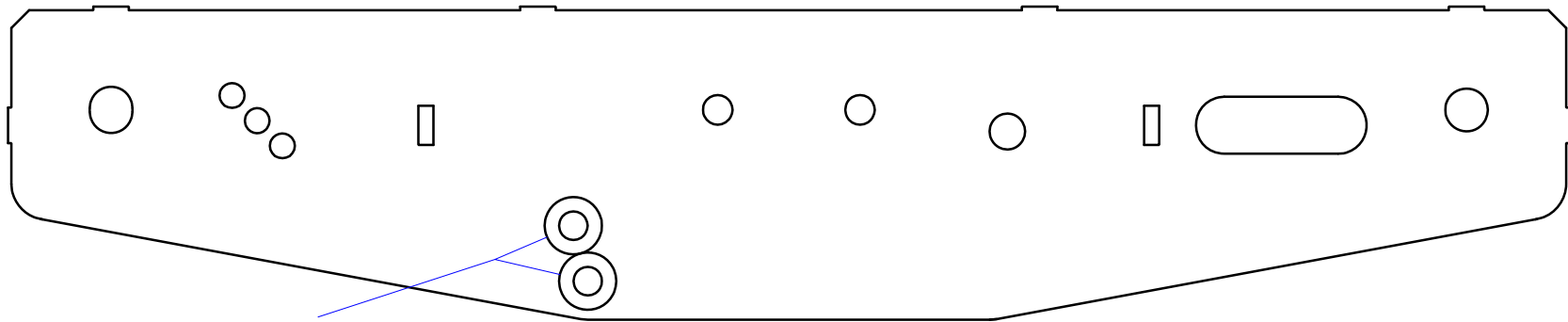
**MechMate**  
www.mechmate.com





 COUNTERSINK ONLY THESE TWO HOLES FROM THE CORRECT SIDE (VIEWED AS ABOVE)

Higher drawing/s:	10 30 420 W	1:2	Dual countersunk holes	05-12-06	B
			Plates no longer handed left/right	26-06-08	C
			Description of change	Date (d-m-y)	Rev.

Material:	STEEL 300MPa	Title	CAR CARRIER PLATE - CSK DRILLED		
 www.mechmate.com		Drawing Number	10 30 450	Process	D
				Revision	C

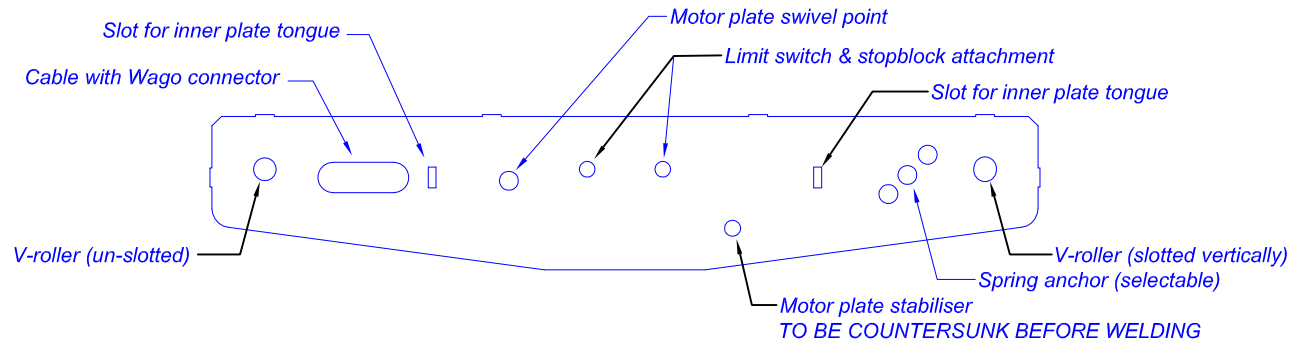
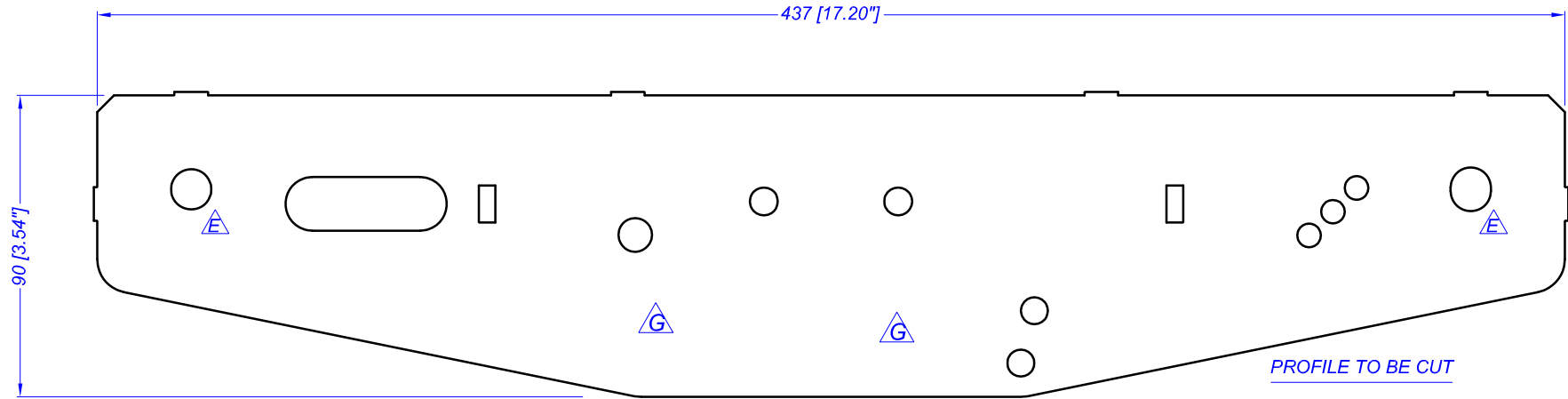
SUPPLY .dxf VERSION OF THIS DRAWING TO THE LASER CUTTING CONTRACTOR FOR REMAINDER OF DIMENSIONS. THE TWO GIVEN DIMENSIONS ARE TO CHECK SCALE.



EXPLANATION OF HOLES - DO NOT CUT THIS PROFILE

Higher drawing/s:	10 30 450 D	1:2	Deleted clearance slots for screw heads	17-04-08	G
			Motor position for 28mm tall rail	06-10-07	F
			Description of change	Date (d-m-y)	Rev.

Material:	5mm (3/16") STEEL 300MPa	Title	CAR CARRIER PLATE - PROFILE CUT		
 <a href="http://www.mechmate.com">www.mechmate.com</a>		Drawing Number	10 30 450	Process	P
		Revision	G		

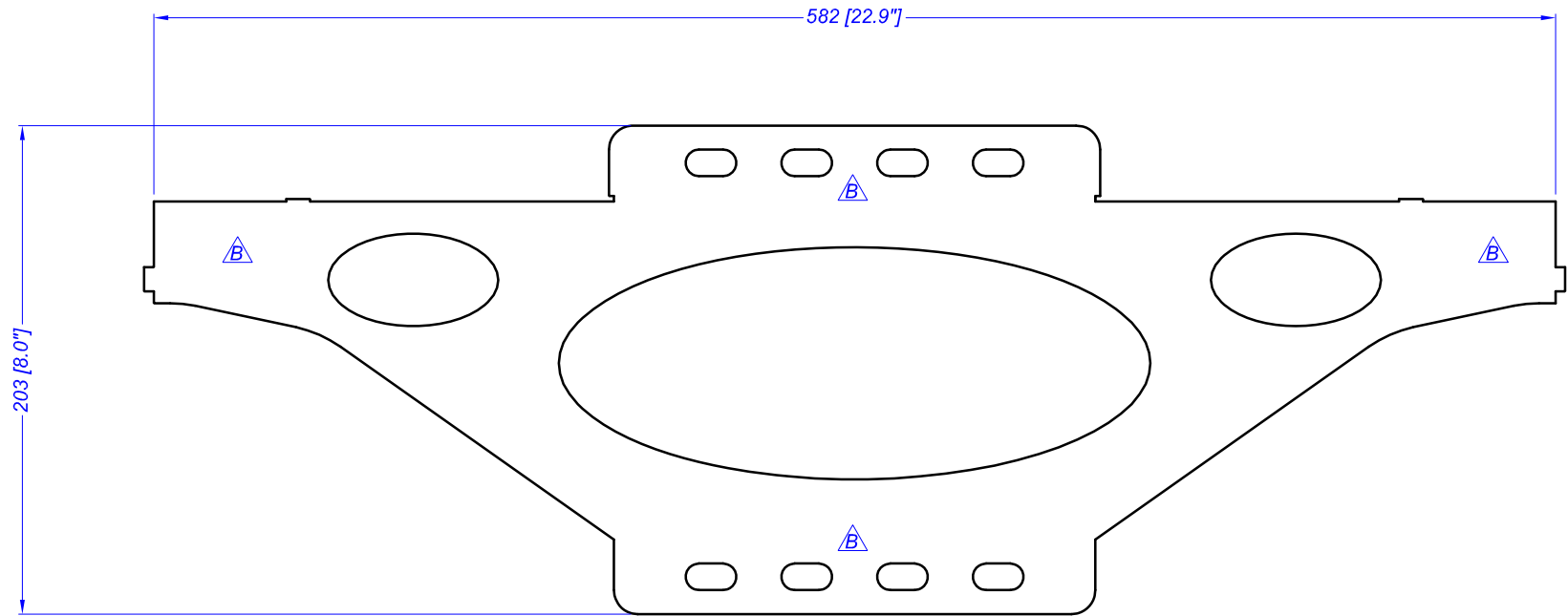

SUPPLY .dxf VERSION OF THIS DRAWING TO THE LASER CUTTING CONTRACTOR.

Higher drawing/s:	10 30 400 W	1:3	Moved slots, deleted small holes	5-11-06	B
			First issue	14-07-06	A
			Description of change	Date (d-m-y)	Rev.
Material:	4mm [3/16"] STEEL 300MPa		Title		
			TOWER CARRIER PLATE - PROFILE CUT		
			Drawing Number	Process	Revision
			10 30 455	P	B

**MechMate**  
www.mechmate.com







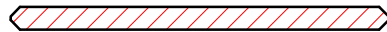
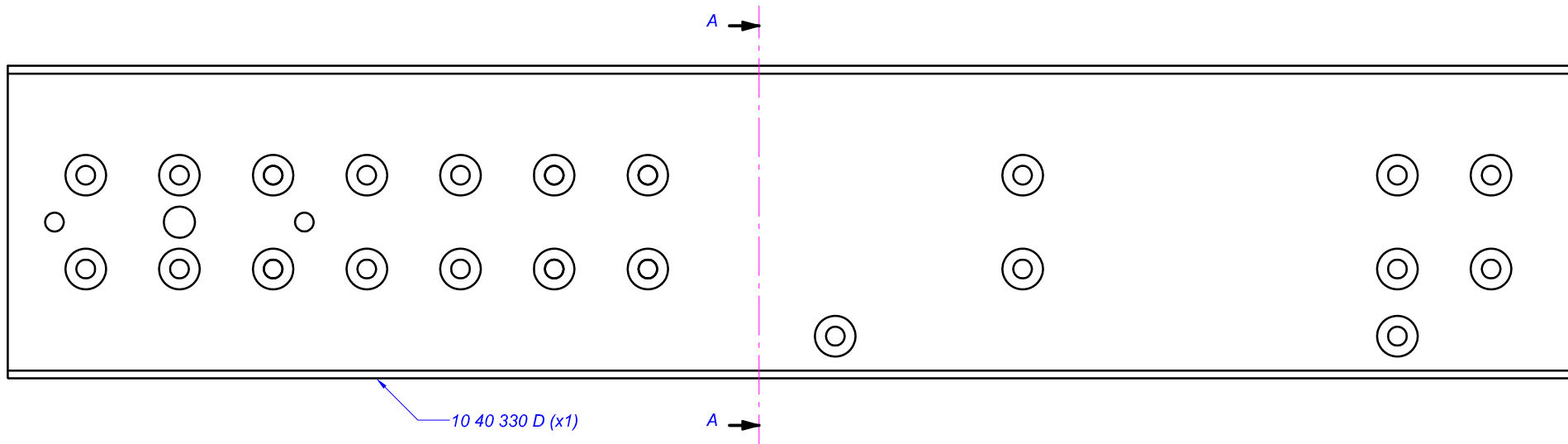

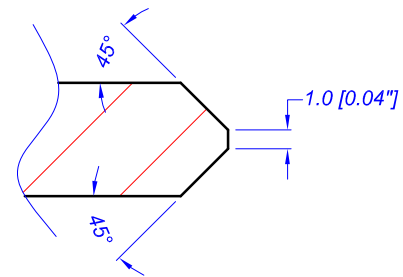

Section A-A



**OPTION**

Higher drawing/s:	10 40 000 A	1:2		
			First issue	20-11-06 A
			Description of change	Date (d-m-y) Rev.
Material:	6mm TOOL STEEL	Title		
 www.mechmate.com		250mm [10"] SLIDE PLATE - MILL/GRIND		
		Drawing Number	Process	Revision
		10 40 330	M	A

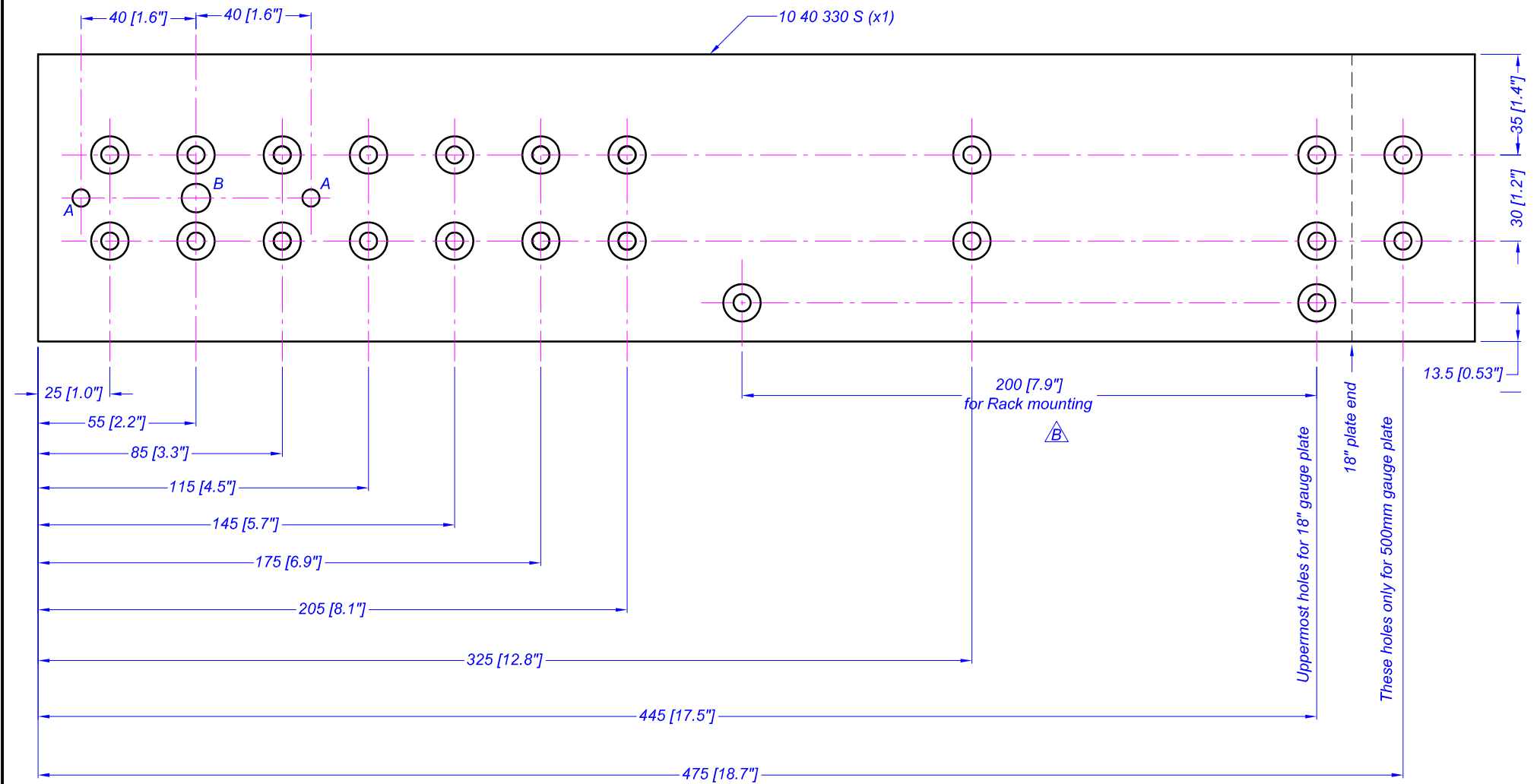

Holes A: 6mm precision location for dowel pins.

Hole B: 10.5mm for drawbolt (10mm)

All other holes countersunk 6.5mm - check screwheads below plate surface.

**OPTION**

Higher drawing/s:	10 40 330 M	1:2	Allow for longer rack	10-10-07	B
			Further 20mm rack length	29-06-08	C
			Description of change	Date (d-m-y)	Rev.
Material:	6mm "GAUGE PLATE"		Title		
 www.mechmate.com			250mm [10"] Z-SLIDE PLATE - DRILLED		
			Drawing Number	Process	Revision
			10 40 330	D	C

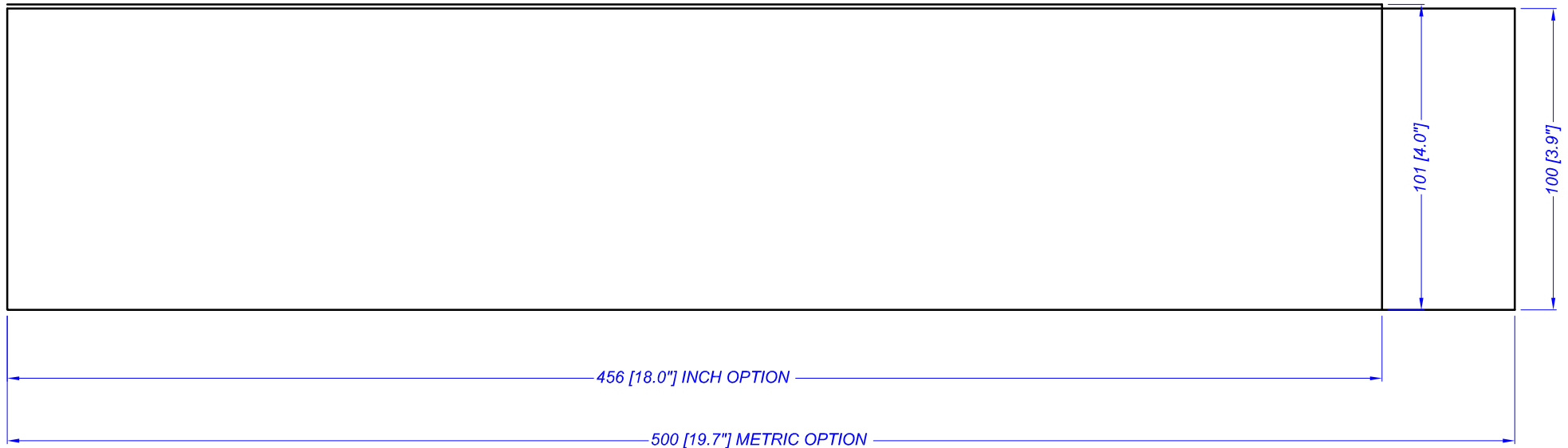

GAUGE PLATE OR GROUND STEEL STOCK FOR  
OIL HARDENING. EITHER 6mm OR 1/4" THICK

**OPTION**

Higher drawing/s:	10 40 330 D	1:2			
			First issue	20-11-06	A
			Description of change	Date (d-m-y)	Rev.
Material:	6mm "GAUGE PLATE"		Title		
			250mm [10"] SLIDE PLATE - SAWN		
	Drawing Number		Process	Revision	
	10 40 330		S	A	
	www.mechmate.com				

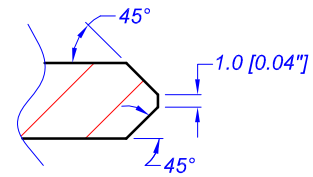
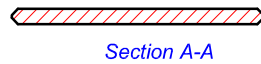
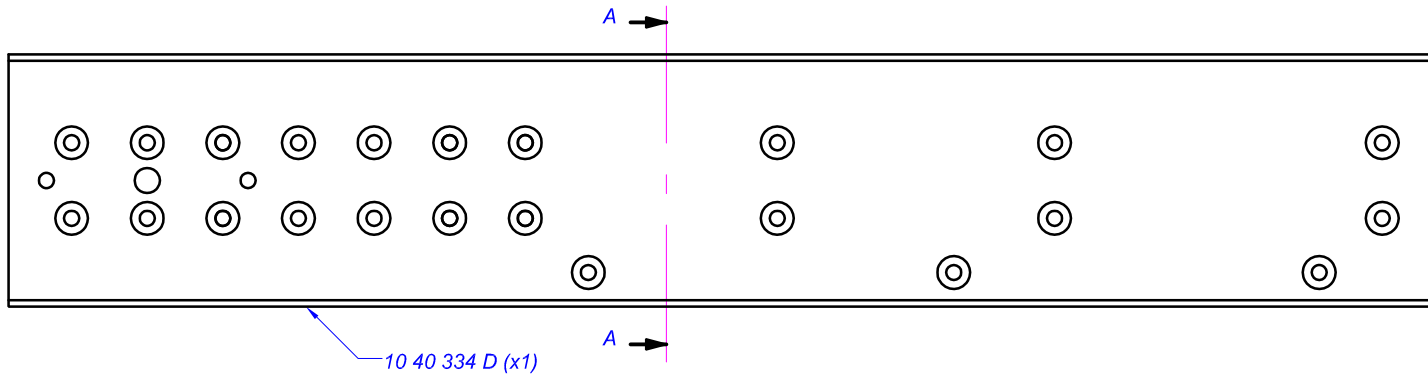

**OPTION**

Higher drawing/s:	10 40 014 A	1:3		
			First issue	10-10-07 A
			Description of change	Date (d-m-y) Rev.
Material:	6mm TOOL STEEL		Title	
			350mm SLIDE PLATE - MILLED/GROUND	
	Drawing Number		Process	Revision
	10 40 334		M	A
	www.mechmate.com			

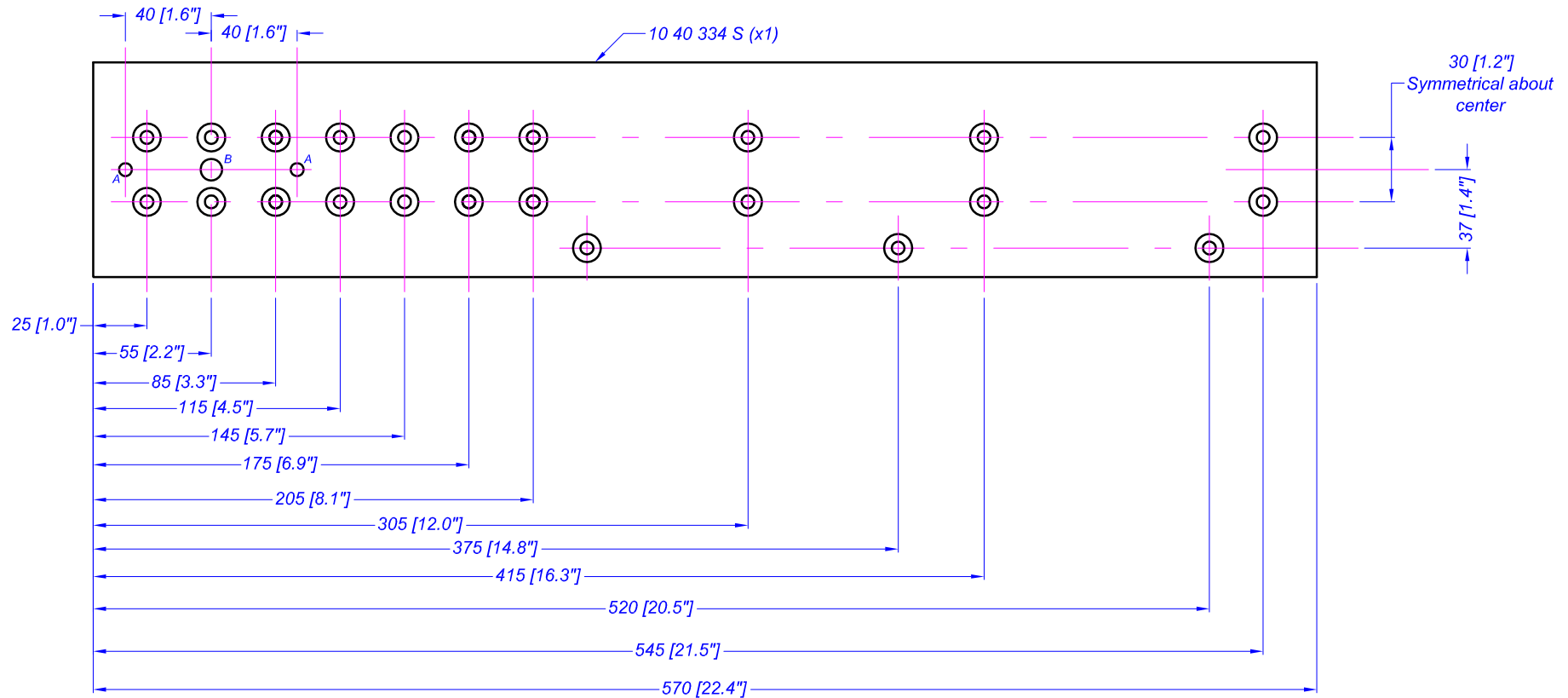

Holes A: 6mm precision location for dowel pins.

Hole B: 10.5mm for drawbolt (10mm)

All other holes countersunk 6.5mm - check screwheads below plate surface.

**OPTION**

Higher drawing/s:	10 40 334 M	1:3		
			First issue	10-10-07 A
			Description of change	Date (d-m-y) Rev.
Material:	6mm "GAUGE PLATE"		Title	
			350mm [14"] Z-SLIDE PLATE - DRILLED	
	Drawing Number		Process	Revision
	10 40 334		D	A
	www.mechmate.com			

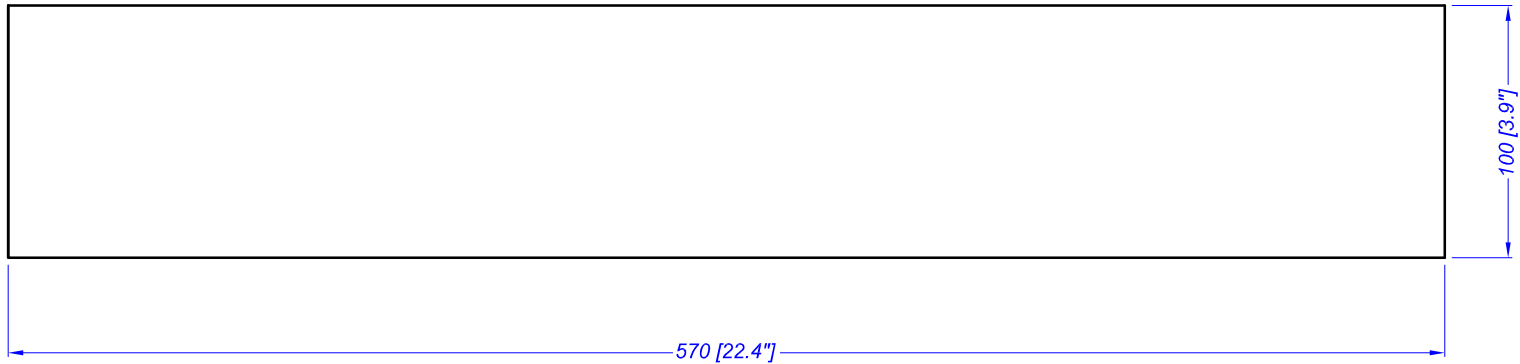

GAUGE PLATE OR GROUND STEEL  
 STOCK FOR OIL HARDENING.  
 EITHER 6mm OR 1/4" THICK

**OPTION**

Higher drawing/s:	10 40 334 D	1:3			
			First issue	10-10-07	A
			Description of change	Date (d-m-y)	Rev.
Material:	6mm "GAUGE PLATE"		Title		
			350mm [14"] SLIDE PLATE - SAWN		
	Drawing Number		Process	Revision	
	10 40 334		S	A	
	www.mechmate.com				

2 Tapped holes for spring  
 bracket in back of tube  
 Location determined acc. to spring

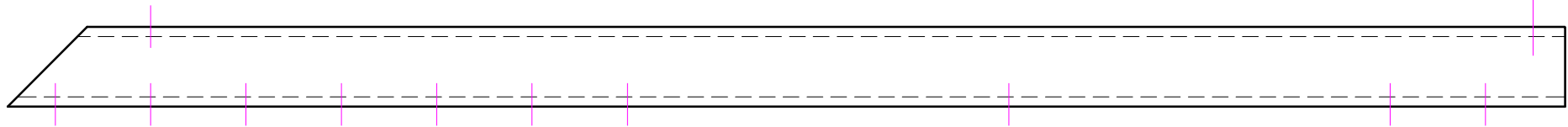

This hole 10.5mm right through. All other holes tapped M6 through one face only

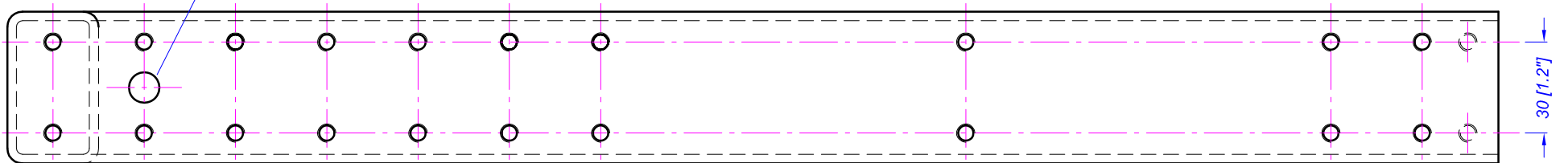

This view from back/bottom of tube. Most holes only through this one face.

10 40 360 S

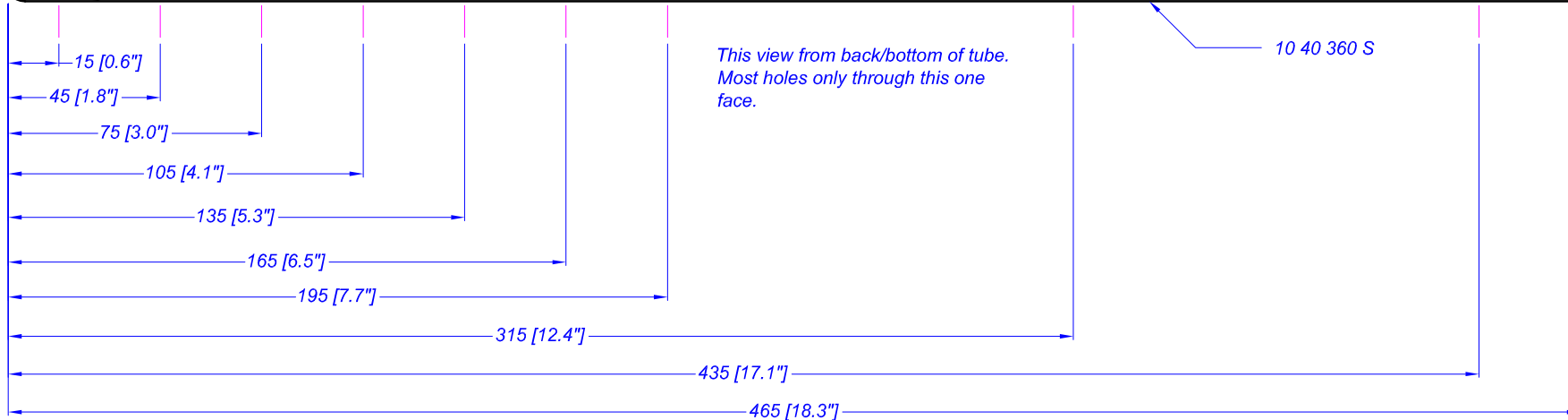

**OPTION**

Higher drawing/s:	10 40 000 A	1:2	Mounting for strut bracket	10-10-07	B
			Floated spring bracket mounting holes	27-06-08	C
			Description of change	Date (d-m-y)	Rev.
Material:	3mm STEEL TUBING		Title		
			250mm [10"] SLIDE TUBE - DRILL & TAP		
	Drawing Number		Process	Revision	
	10 40 360		D	C	

**MechMate**  
 www.mechmate.com



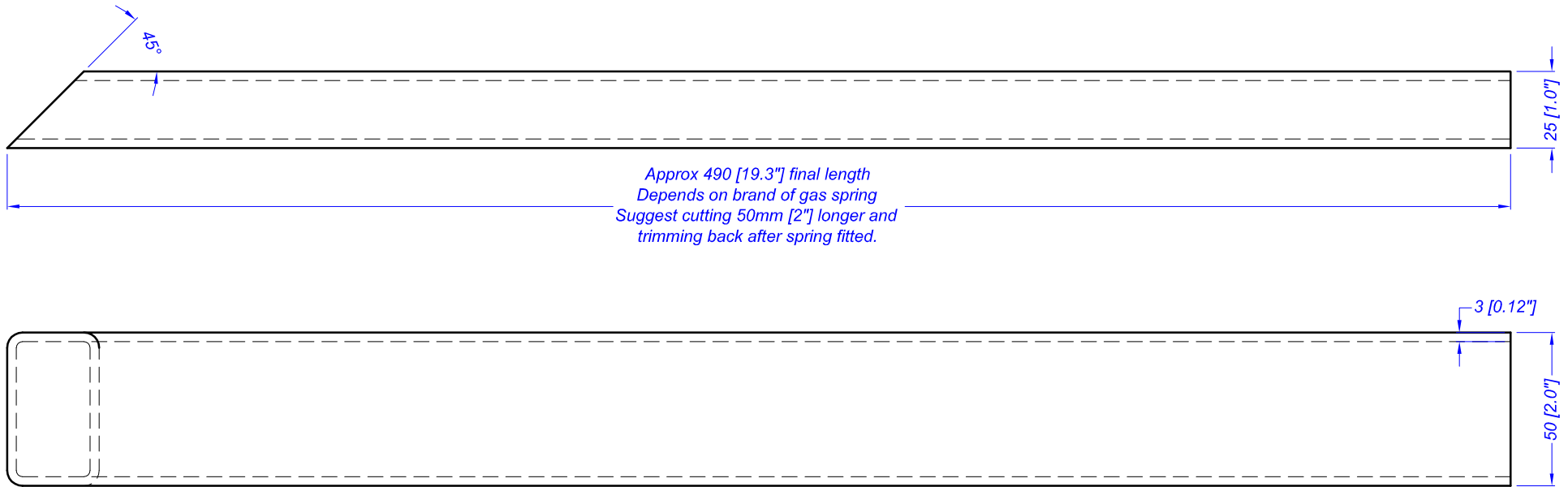

**OPTION**

Higher drawing/s:	10 40 360 D	1:2	First issue	14-11-06	A
			Add allowance for gas spring variance	27-06-08	B
			Description of change	Date (d-m-y)	Rev.
Material:	50 x 25 x 3 STEEL TUBING		Title		
			250mm [10"] Z-SLIDE TUBE - SAWN		
	Drawing Number		Process	Revision	
	10 40 360		S	B	

**MechMate**  
www.mechmate.com

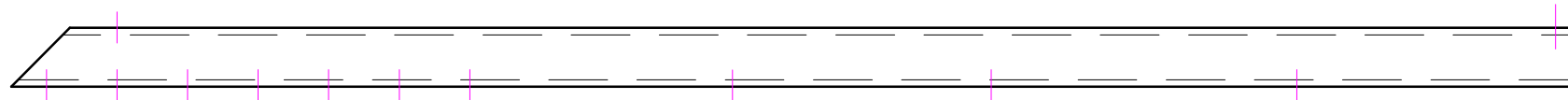

This hole 10.5mm right through. All other holes tapped M6 through one face only

2 Tapped holes for spring bracket in back of tube  
Location determined acc. to spring  $\triangle B$

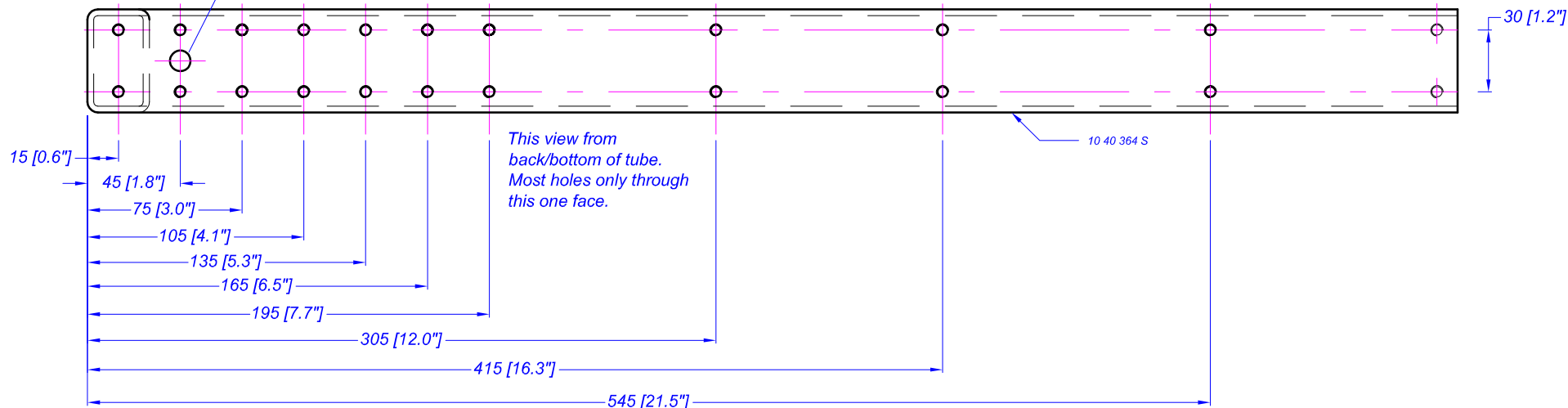

$\triangle B$

**OPTION**

Higher drawing/s:	10 40 014 A	1:3	Floated spring bracket mounting holes	27-06-08	B
		$\triangle B$	First issue	10-10-07	A
			Description of change	Date (d-m-y)	Rev.
Material:	3mm STEEL TUBING		Title	350mm SLIDE TUBE - DRILLED & TAPPED	
MechMate www.mechmate.com			Drawing Number	10 40 364	Process D
					Revision B

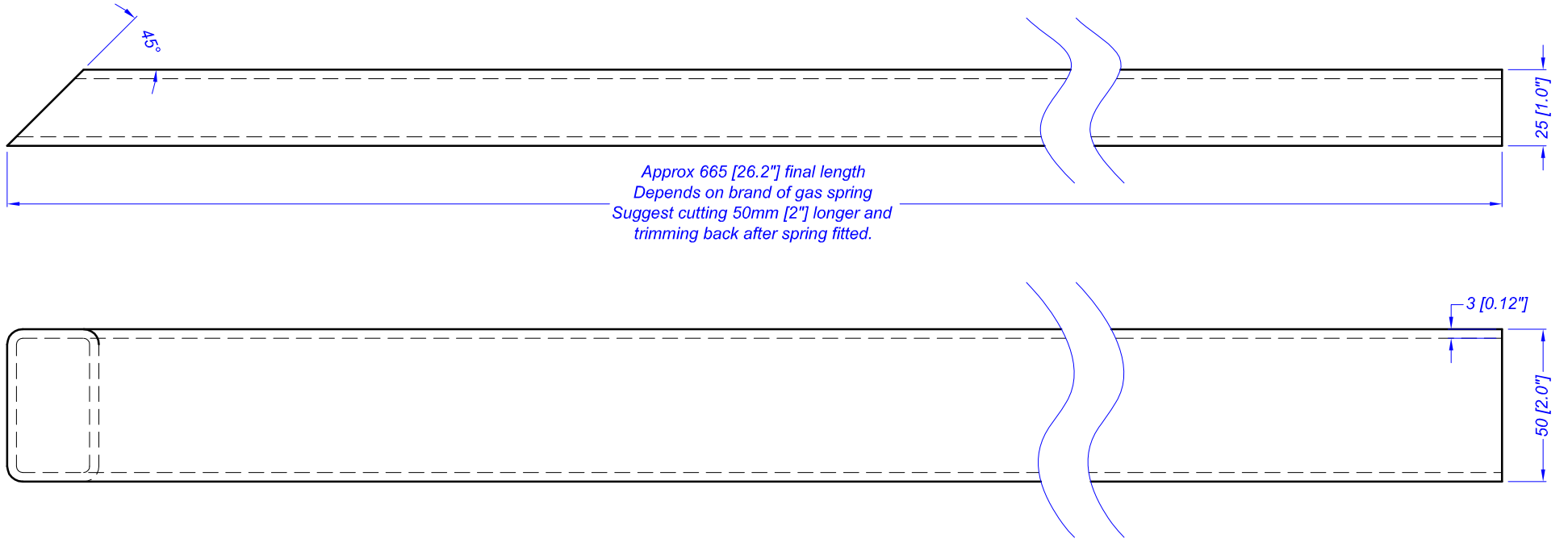

**OPTION**

Higher drawing/s:	10 40 364 D	1:2	First issue	10-10-07	A
			Add allowance for gas spring variance	27-06-08	B
			Description of change	Date (d-m-y)	Rev.
Material:	50 x 25 x 3 STEEL TUBING		Title		
			350mm [14"] Z-SLIDE TUBE - SAWN		
	Drawing Number		Process	Revision	
	10 40 364		S	B	

**MechMate**  
www.mechmate.com

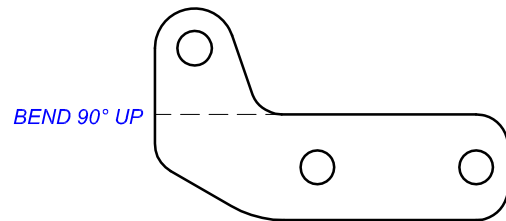
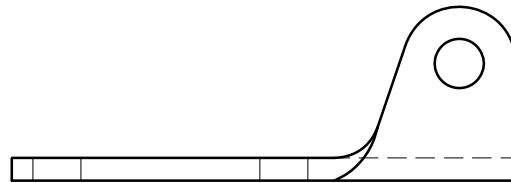
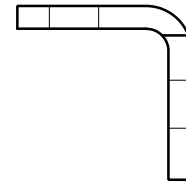
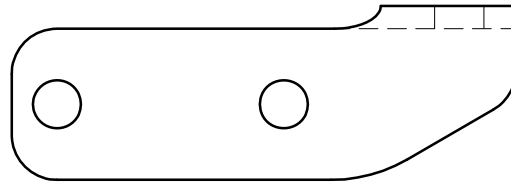

Higher drawing/s:	10 40 000 A	1:1		
			First issue	10-10-07 A
			Description of change	Date (d-m-y) Rev.
Material:	3mm [1/8"] STEEL 300MPa		Title	
			UPPER STRUT BRACKET - BEND	
	Drawing Number		Process	Revision
	10 40 372		B	A
	www.mechmate.com			

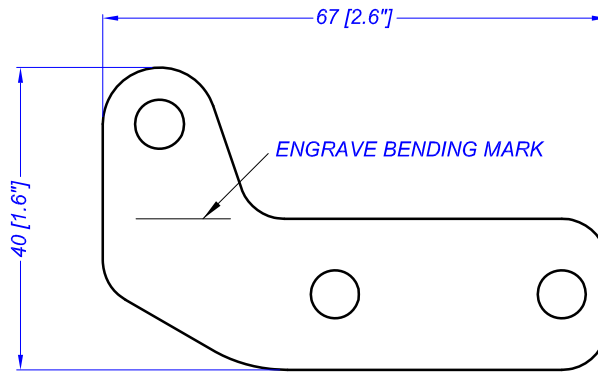

Higher drawing/s:	10 40 372 B	1:1		
			First issue	10-10-07 A
			Description of change	Date (d-m-y) Rev.
Material:	3mm [1/8"] STEEL 300MPa	Title		
 <a href="http://www.mechmate.com">www.mechmate.com</a>		UPPER STRUT BRACKET - LASER PROFILE		
		Drawing Number	Process	Revision
		10 40 372	P	A

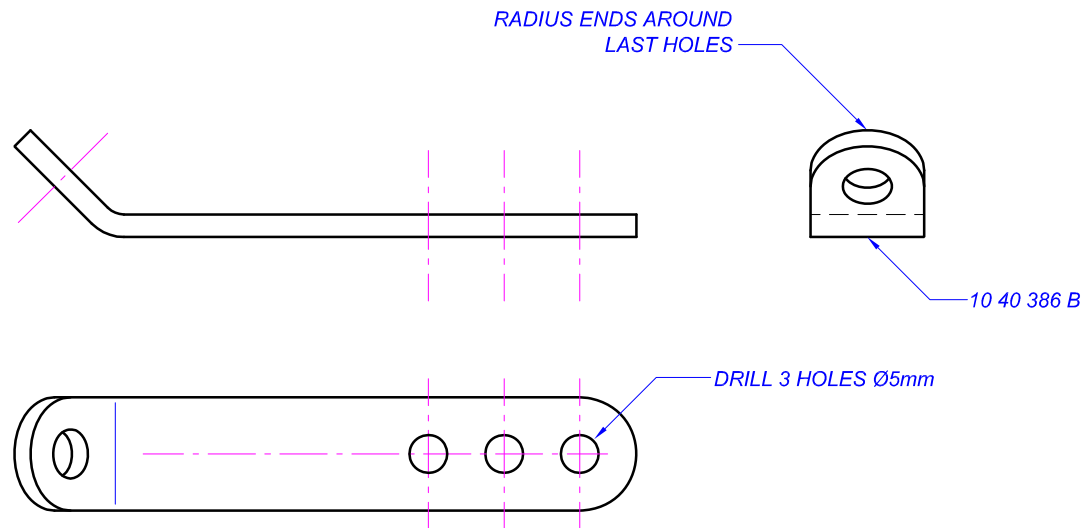

CHECK THESE DIMENSIONS AGAINST THE Z-MOTOR TENSIONING SPRING

Note: The Z-Motor spring should have a tension of about 12kg [25 #] when in the center of the 3 holes. The adjacent holes are for adjusting the tension.

**OPTION**

Higher drawing/s:	M5 10 150 A	1:1	Note added	18-05-07	B
			First issue	30-11-06	A
			Description of change	Date	Rev.
Material:	3mm STEEL		Title		
			Z-SPRING ANCHOR - DRILLED & RADIUSED		
	Drawing Number		Process	Revision	
	10 40 386		D	B	
	www.mechmate.com				

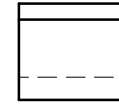
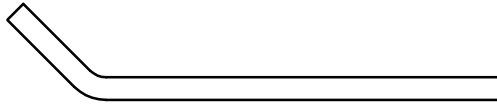

Development

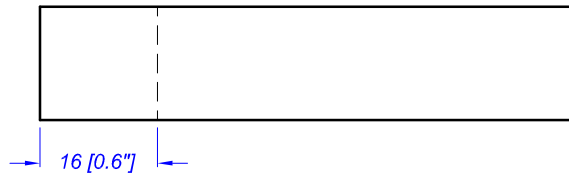

Note: The length and angle of this spring anchor is best determined in-situ. Pull the spring with 12kg [25#] force (use "fisherman's scale") and then figure out how to anchor it. There are too many variables to try and make an exact design for a simple little plate. . . . .

**OPTION**

Higher drawing/s:	10 40 386 D	1:1	Note added	18-05-07	B
			First issue	30-11-06	A
			Description of change	Date	Rev.
Material:	3mm STEEL		Title		
			Z-SPRING ANCHOR - BEND		
	Drawing Number		Process	Revision	
	10 40 386		B	B	
	www.mechmate.com				

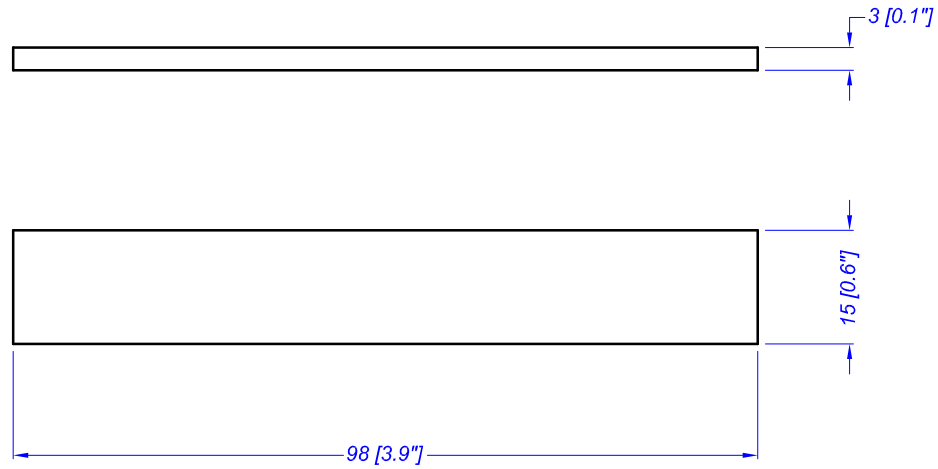

**OPTION**

Higher drawing/s:	10 40 386 B	1:1			
			First issue	30-11-06	A
			Description of change	Date (d-m-y)	Rev.
Material:	15 X 3mm STEEL FLAT		Title		
			Z-SPRING ANCHOR - BLANK		
	MechMate www.mechmate.com		Drawing Number	Process	Revision
			10 40 386	S	A



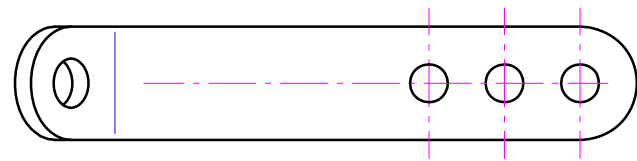
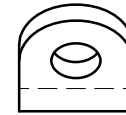
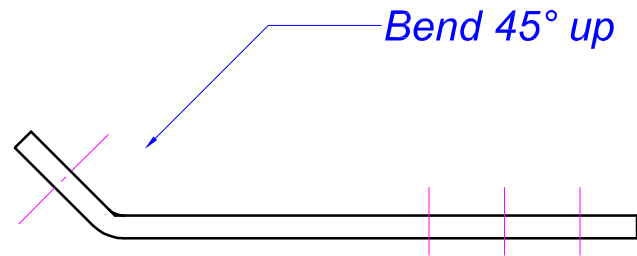

Developed Part t=3mm [ $\frac{1}{8}$ "]

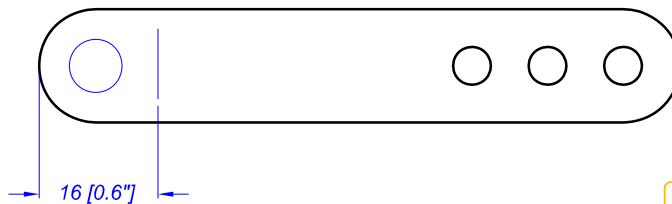

**OPTION**

Higher drawing/s:	M5 10 150 A	1:1			
			First issue	17-06-08	A
			Description of change	Date (d-m-y)	Rev.
Material:	3mm [1/8"] STEEL	Title			
		Z-SPRING ANCHOR - BEND			
Drawing Number			Process	Revision	
10 40 387			B	A	
www.mechmate.com					

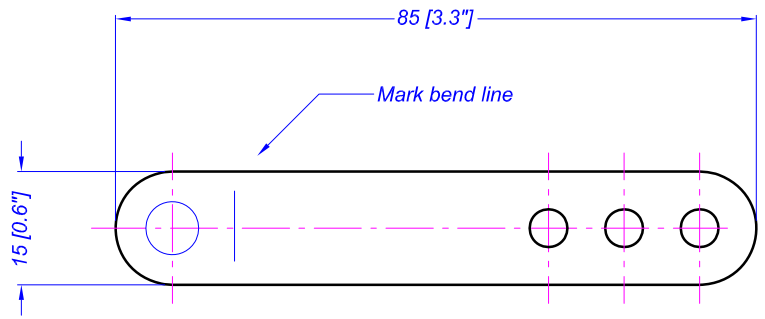

**OPTION**

Higher drawing/s:	10 40 387 B	1:1		
			First issue	17-06-08 A
			Description of change	Date (d-m-y) Rev.
Material:	3mm STEEL		Title	
			Z-SPRING ANCHOR - PROFILE	
	Drawing Number	Process	Revision	
	10 40 387	P	A	

**MechMate**  
www.mechmate.com

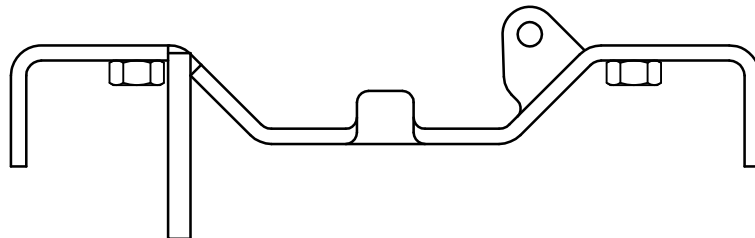
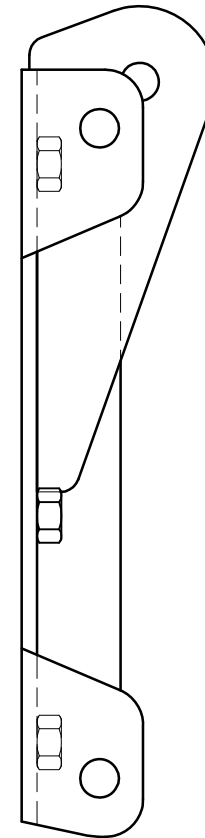
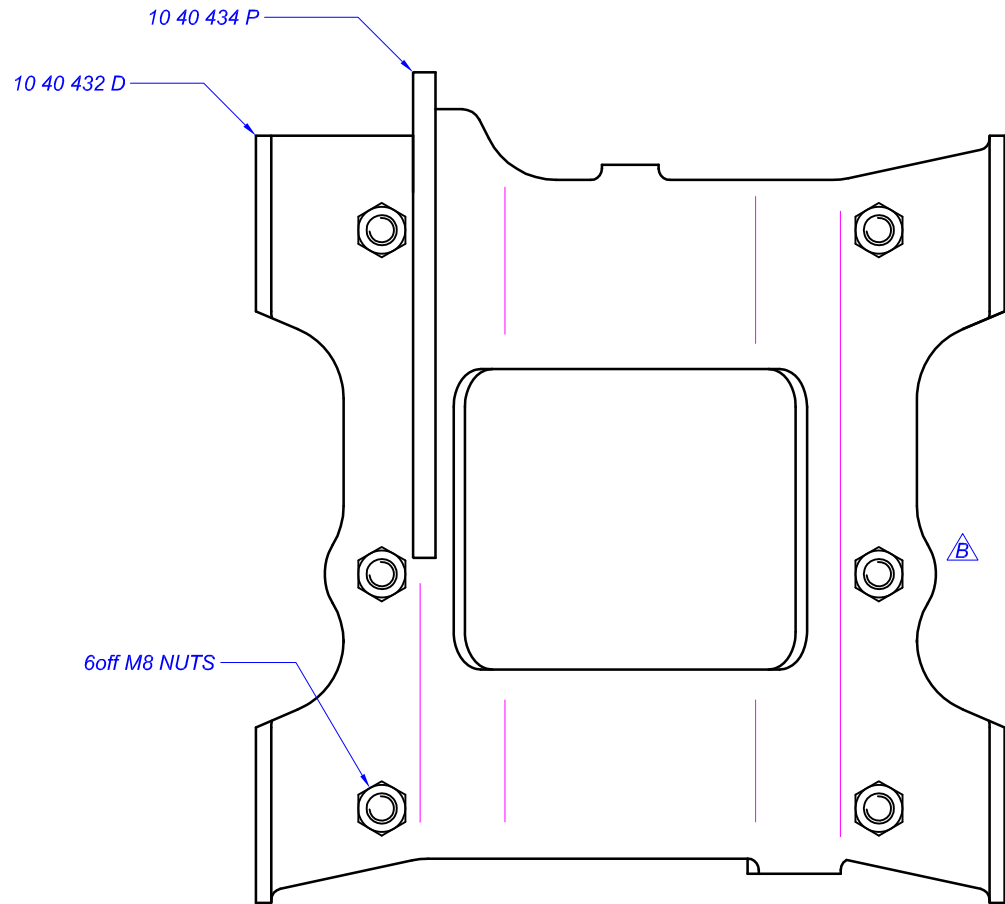

Higher drawing/s:	10 40 000 A	1:2	Optional 3rd roller pair position	25-09-07	B
			First issue	21-11-06	A
			Description of change	Date (d-m-y)	Rev.
Material:	STEEL		Title		
			SPIDER - WELDED		
Drawing Number		Process	Revision		
10 40 430		W	B		

**MechMate**  
www.mechmate.com

10 40 432 B

DRILL & TAP 6off HOLES M8

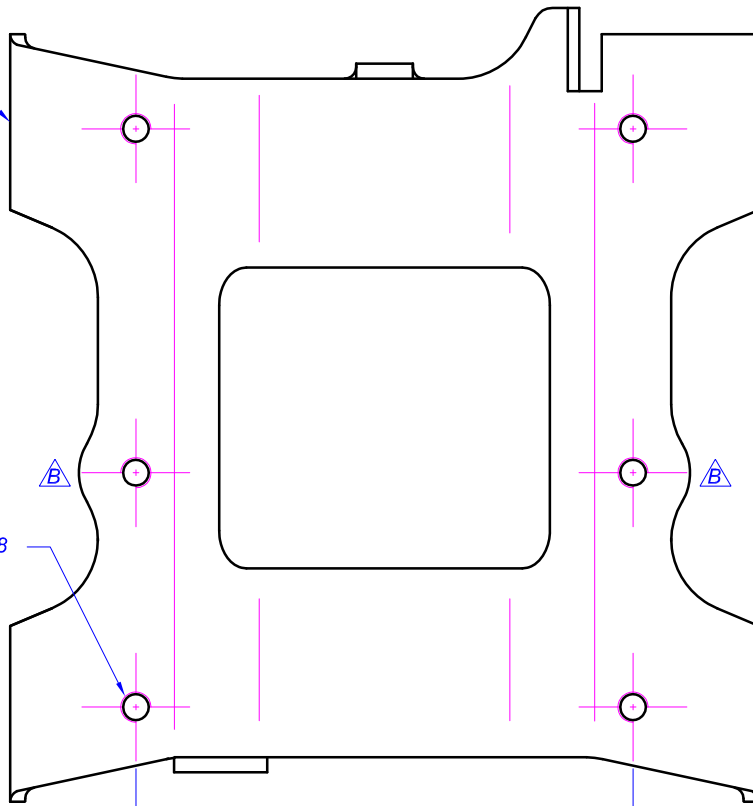

(132 [5.2"]) approx  
TO SUIT SLIDE & V-ROLLERS

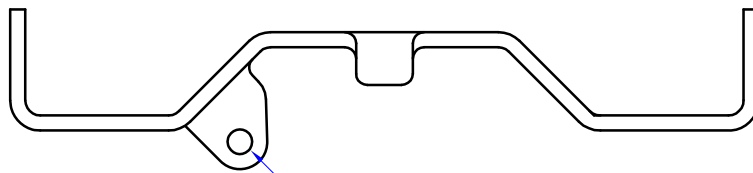

DRILL Ø6.5mm  
or to suit GAS SPRING

(Gas spring must be a  
loose fit in the hole)

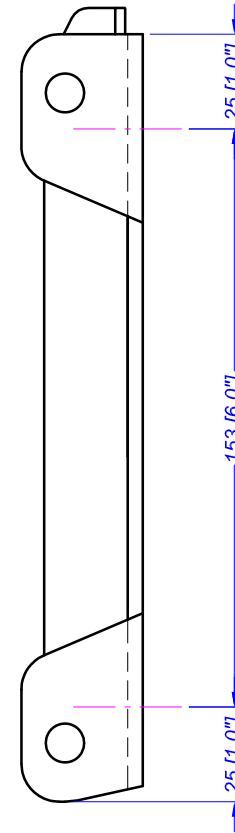

Higher drawing/s:	10 40 430 W	1:2	Optional 3rd roller pair position	25-09-07	B
			First issue	21-11-06	A
			Description of change	Date (d-m-y)	Rev.
Material:	STEEL 300MPa		Title		
 www.mechmate.com			SPIDER PLATE - DRILLED		
			Drawing Number	Process	Revision
			10 40 432	D	B

This face to be flat and non-twisted  
after bending within 1mm [0.04"]

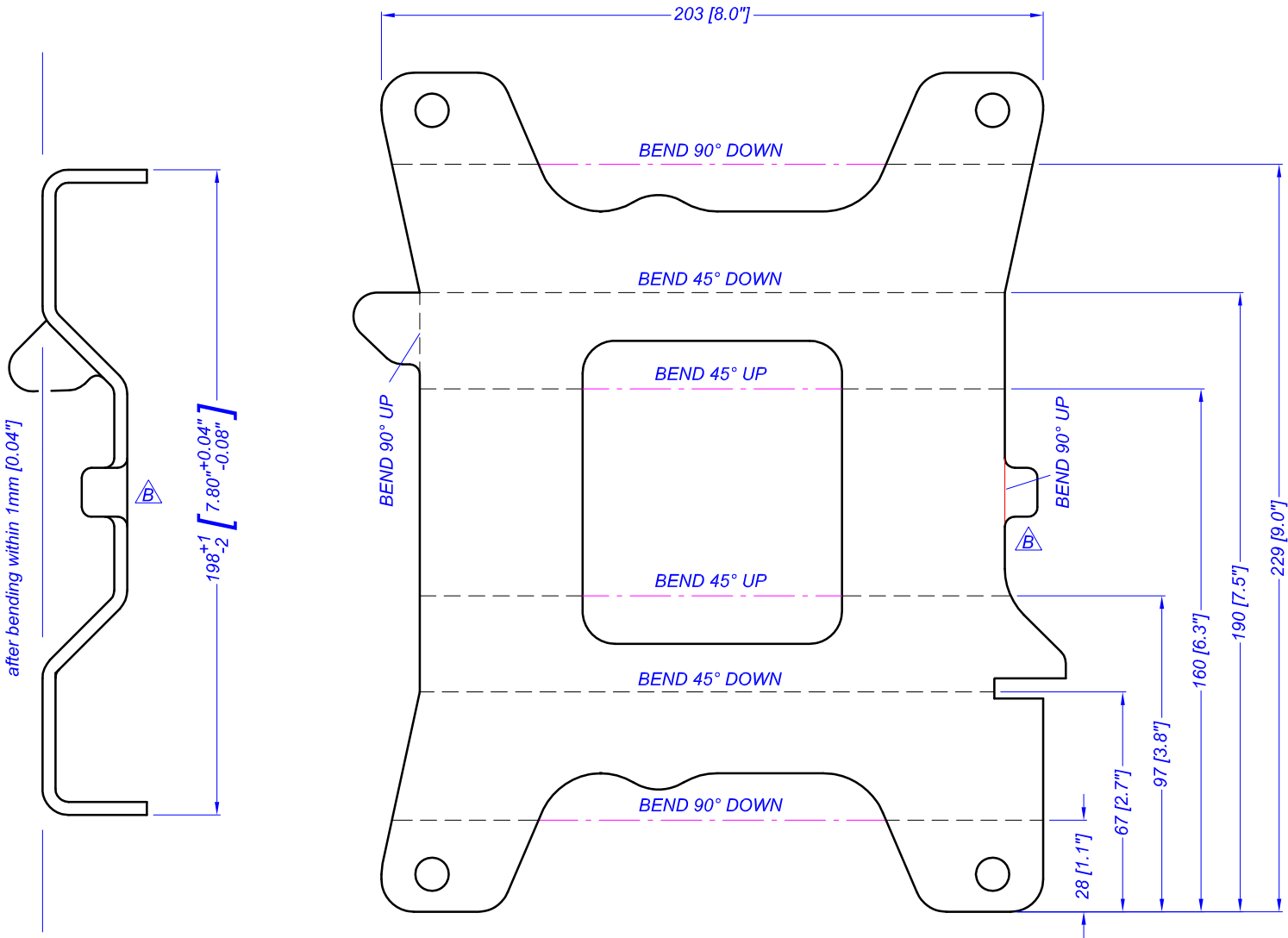

Higher drawing/s:	10 40 432 D	1:2	Shape changed. bend added	19-11-06	B
			Flatness tolerance added	27-06-08	A
			Description of change	Date (d-m-y)	Rev.

Material:	5mm [3/16"] STEEL 300MPa	Title			
 www.mechmate.com		SPIDER PLATE - BEND			
		Drawing Number	Process	Revision	
		10 40 432	B	C	

Engrave markings

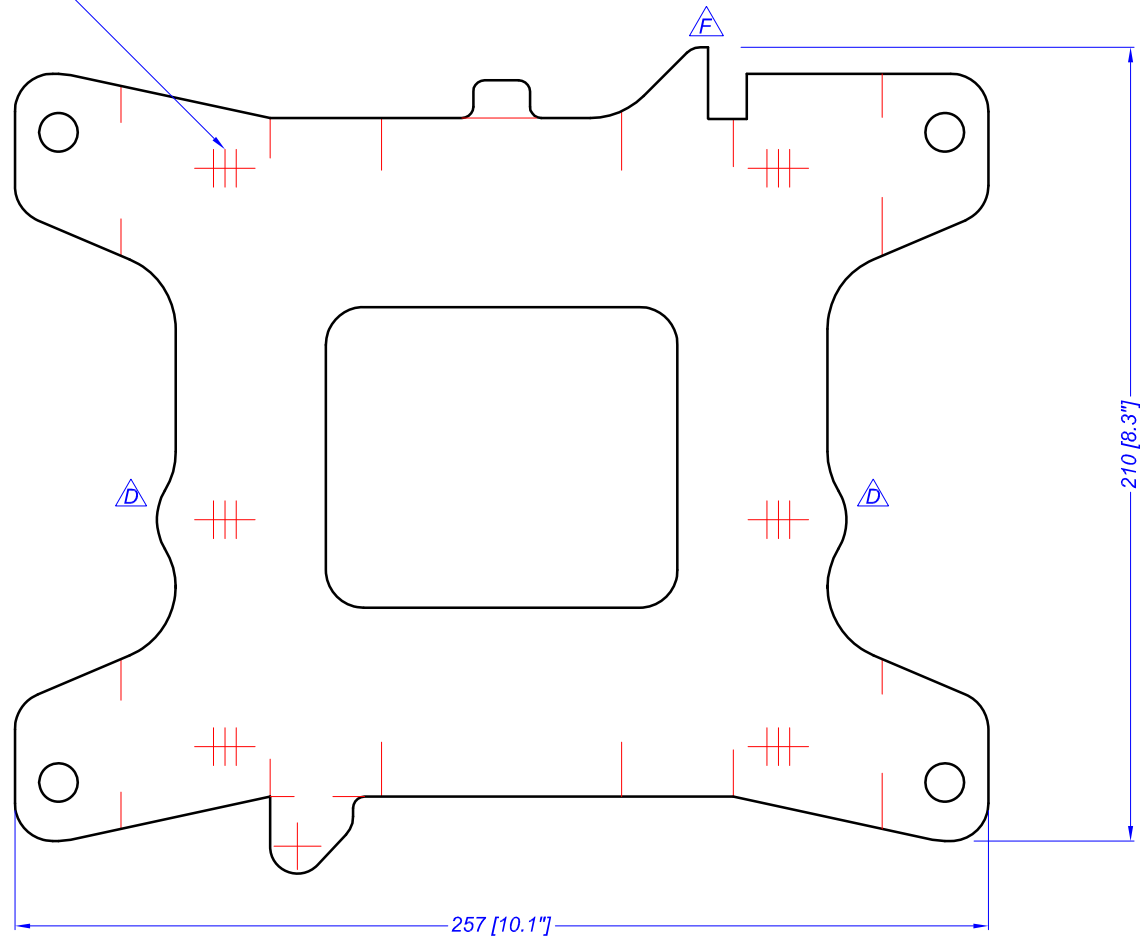

Higher drawing/s:	10 40 432 B	1:2	Widen notch by 2.5mm	26-06-08	F
			Metric thickness changed to 5mm	08-06-08	E
			Description of change	Date (d-m-y)	Rev.
Material:	5mm [3/16"] STEEL 300MPa		Title		
 www.mechmate.com			SPIDER PLATE - PROFILE CUT		
			Drawing Number <b>10 40 432</b>	Process <b>P</b>	Revision <b>F</b>

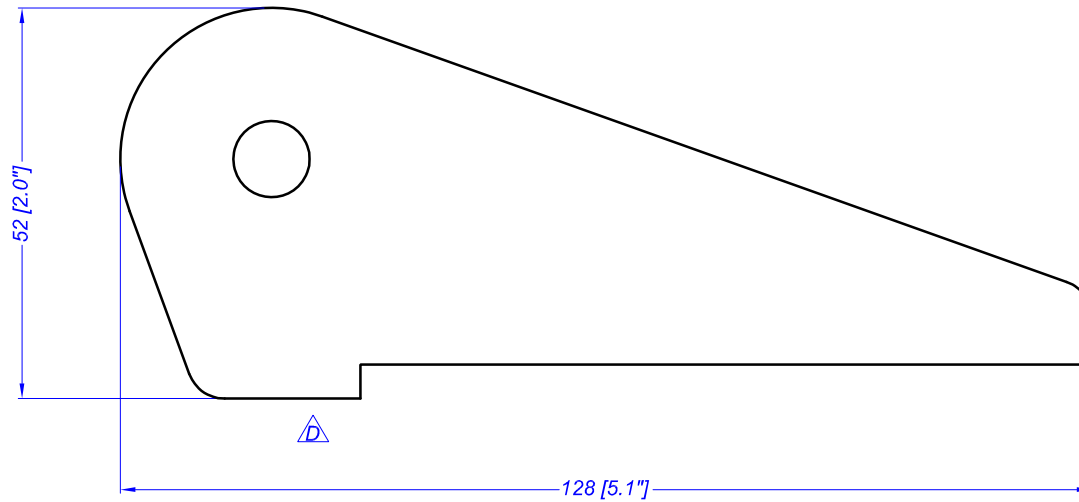

Higher drawing/s:	10 40 430 W	1:1	Shape change to lower motor position	21-11-06	C
			Increased nose protrusion 2.5mm	27-06-08	D
			Description of change	Date (d-m-y)	Rev.
Material:	6mm [1/4"] STEEL 300MPa		Title		
			MOTOR PLATE LUG - PROFILE CUT		
	Drawing Number		Process	Revision	
	10 40 434		P	D	

**MechMate**  
www.mechmate.com

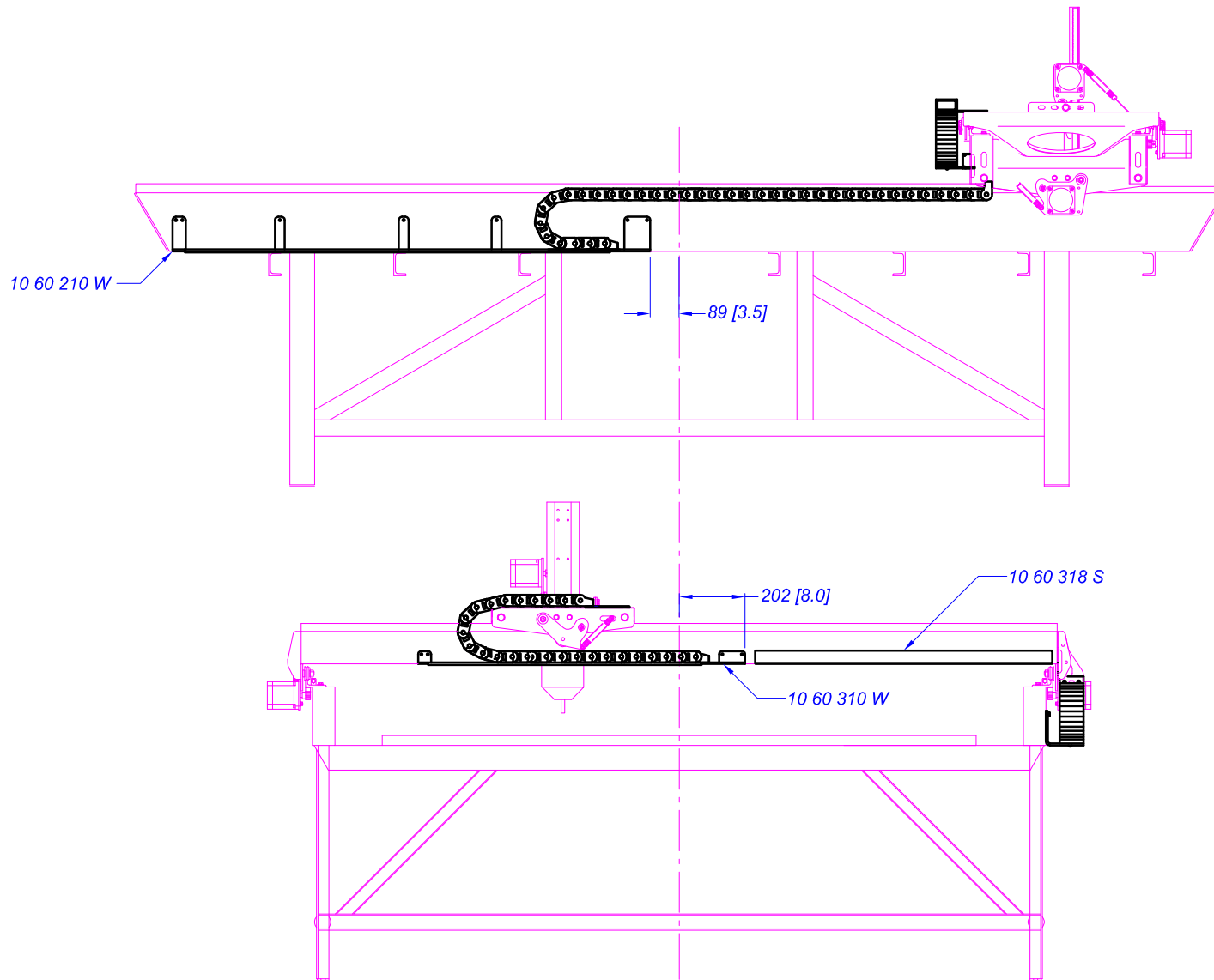

Higher drawing/s:	10 60 000 A	1:20		
			First issue	06-11-07 A
			Description of change	Date (d-m-y) Rev.
Material:	ASSEMBLY		Title	
			CABLE CHAIN ASSEMBLIES	
	Drawing Number		Process	Revision
	10 60 100		A	A

**MechMate**  
www.mechmate.com



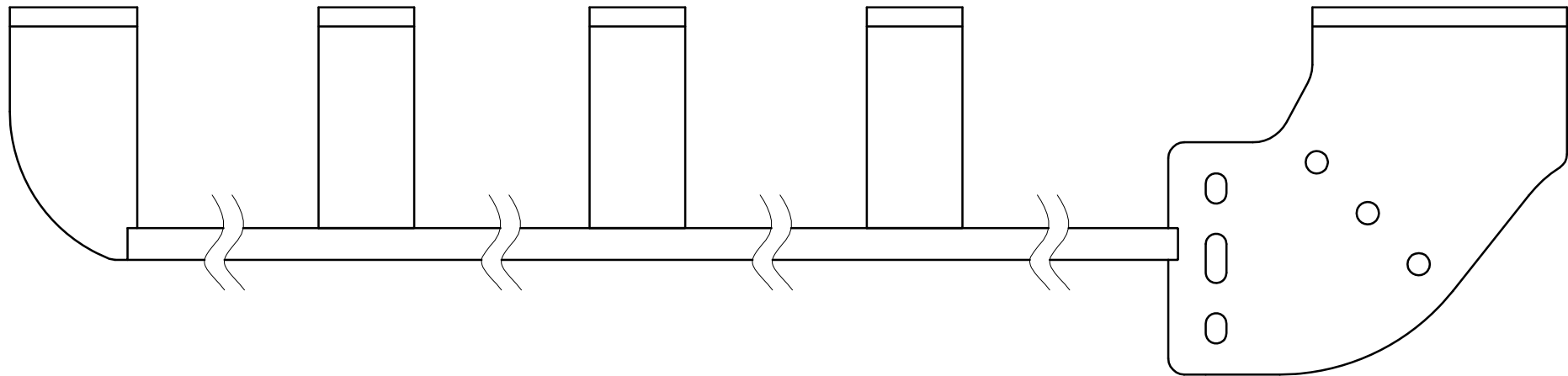
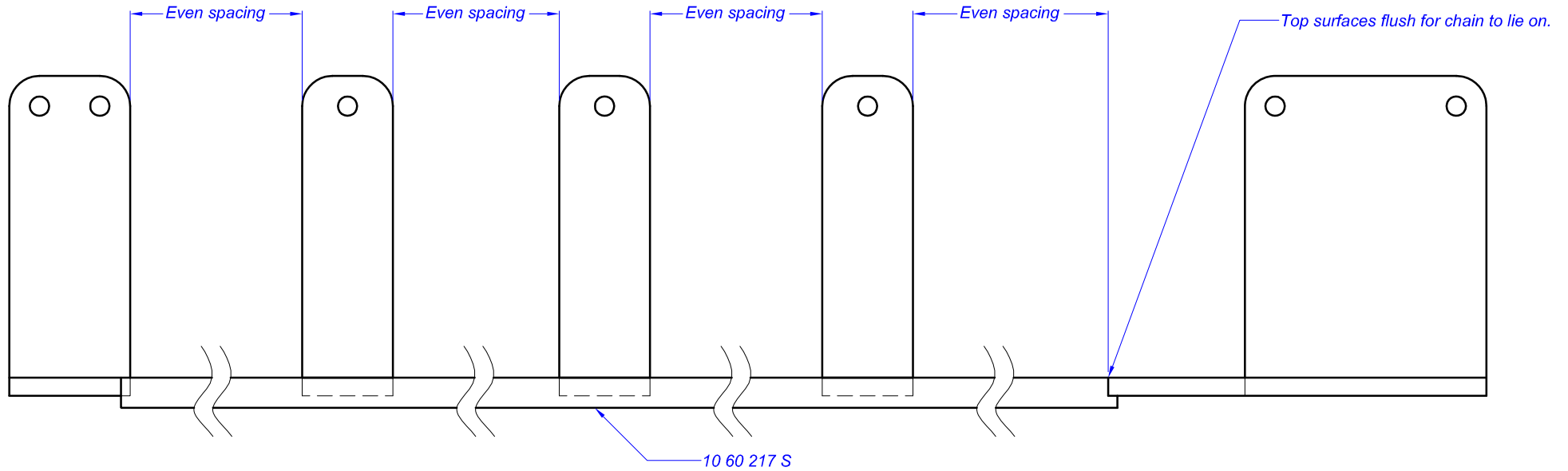

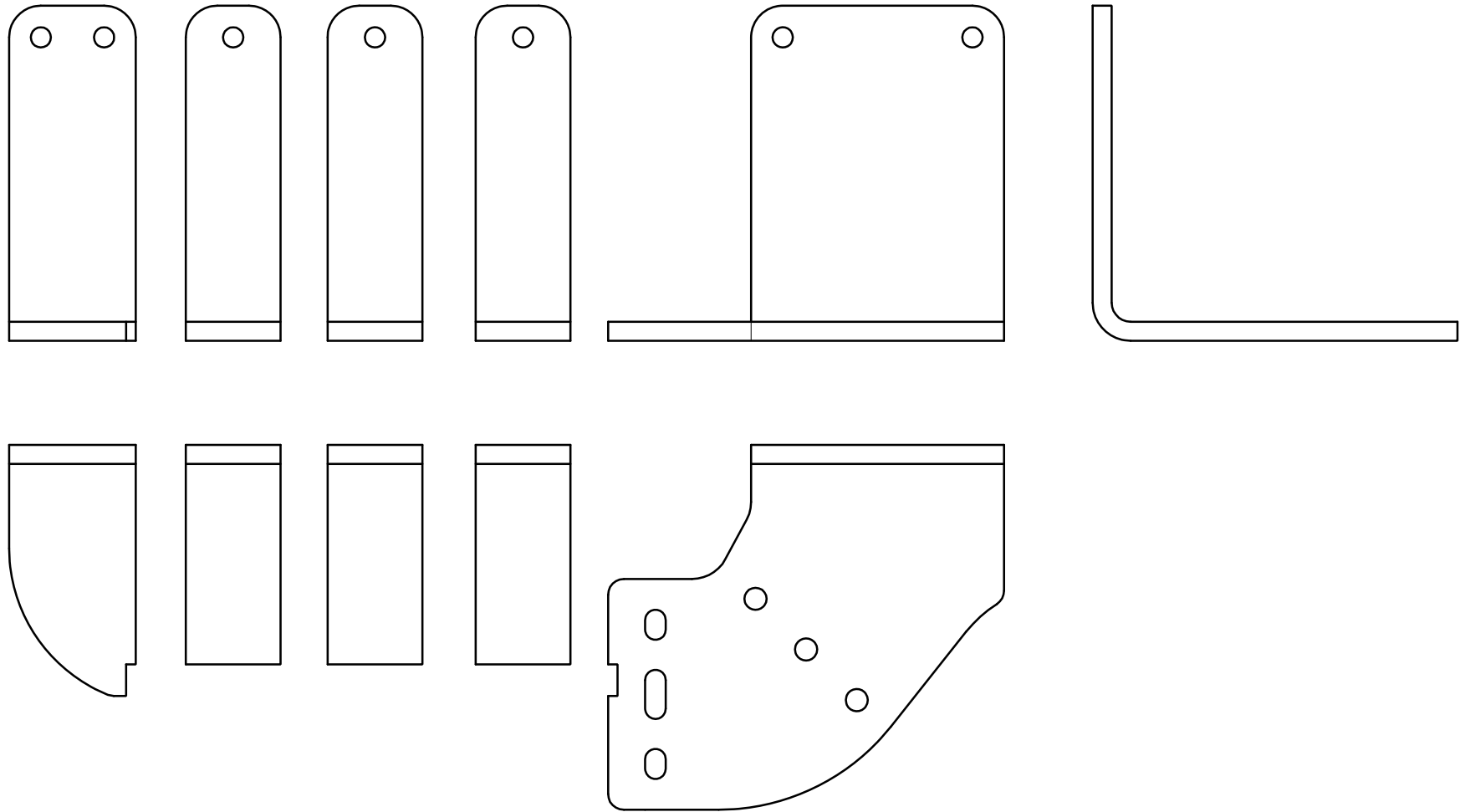

Higher drawing/s:	10 60 100 A	1:2		
		△	First issue	06-11-07 A
			Description of change	Date (d-m-y) Rev.
Material:	STEEL		Title	
			X-CABLE CHAIN SHELF - WELD	
Drawing Number		Process	Revision	
10 60 210		W	A	

**MechMate**  
www.mechmate.com



Higher drawing/s:	10 60 210 W	1:2			
			First issue	06-11-07	A
			Description of change	Date (d-m-y)	Rev.
Material:	6mm [1/4"] STEEL 300MPa		Title		
 <a href="http://www.mechmate.com">www.mechmate.com</a>			X-CABLE CHAIN SHELF - CUT		
			Drawing Number	Process	Revision
			10 60 215	S	A

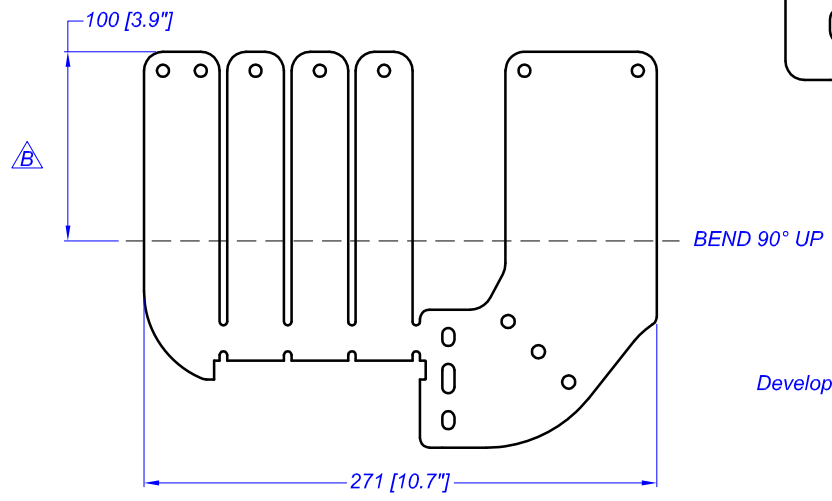
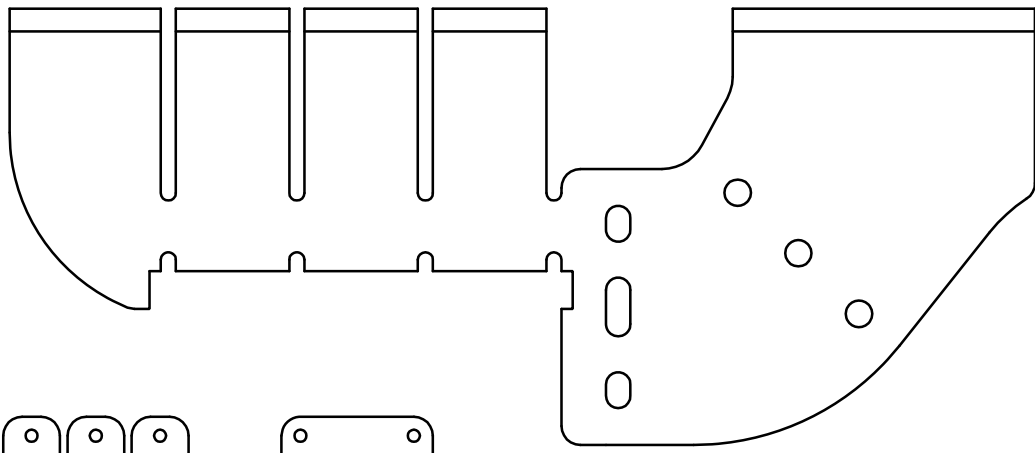
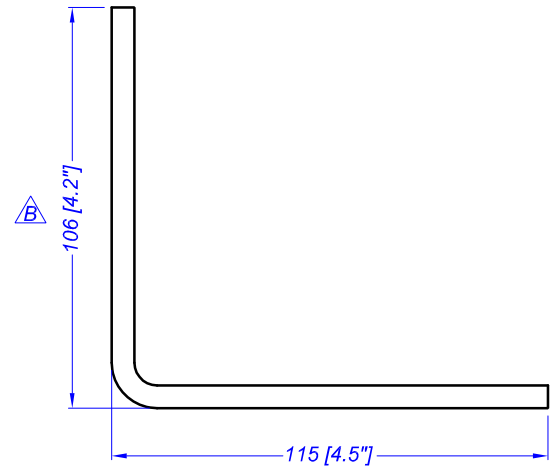
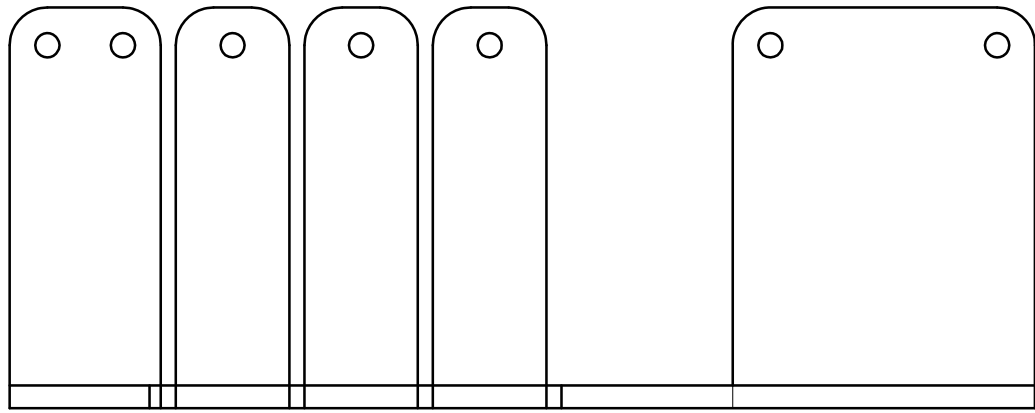

Developed part t = 6mm [1/4"]

Higher drawing/s:	10 60 215 S	1:2	Moved bend location for revised profile	27-06-08	B
			First issue	06-11-07	A
			Description of change	Date (d-m-y)	Rev.
Material:	6mm [1/4"] STEEL 300MPa		Title		
 www.mechmate.com			X-CABLE CHAIN SHELF - BEND		
			Drawing Number <b>10 60 215</b>	Process <b>B</b>	Revision <b>B</b>

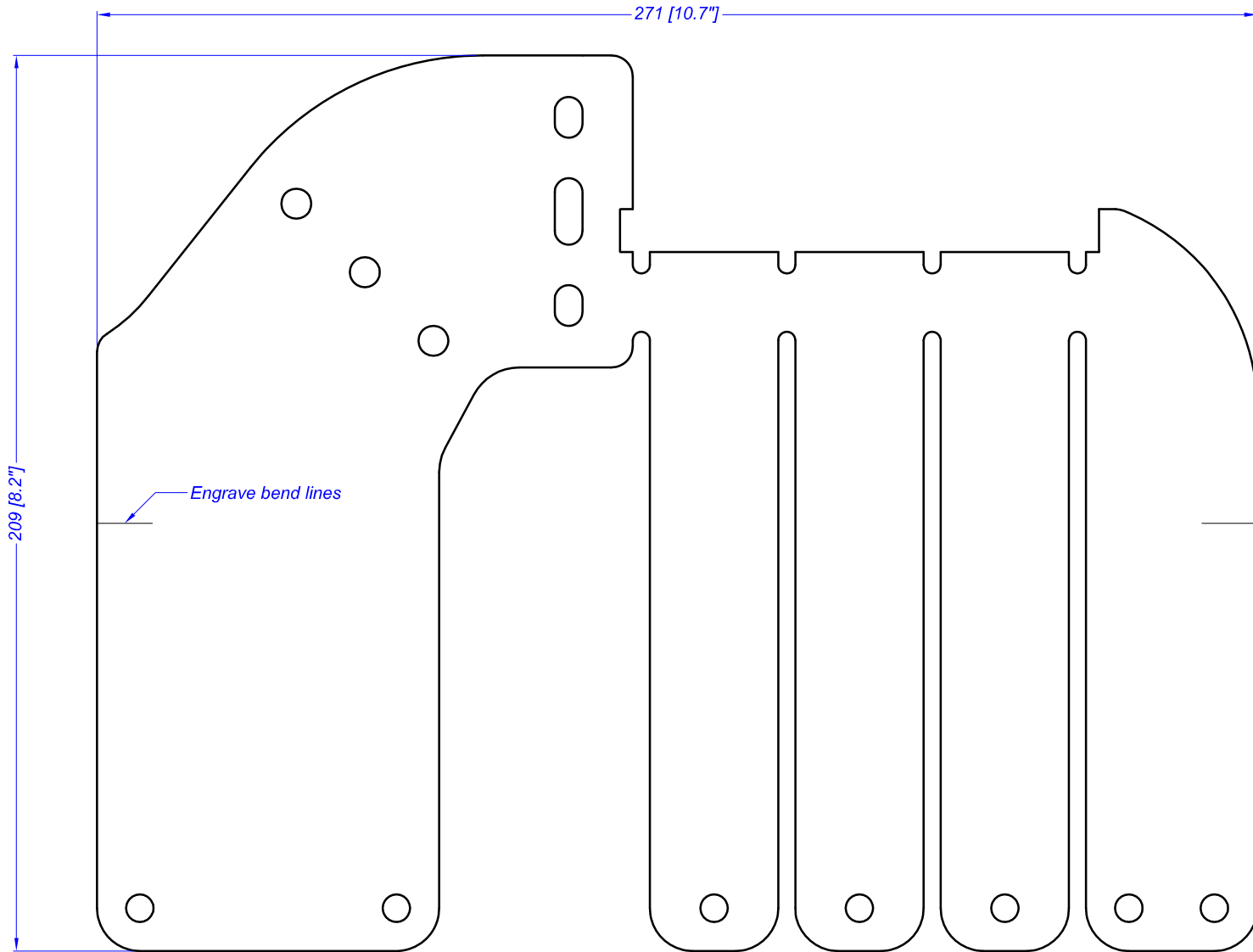



**OPTION**

Higher drawing/s:	10 60 215 B	1:1.5	Lenthened legs	17-06-08	B
			First issue	06-11-07	A
			Description of change	Date (d-m-y)	Rev.
Material:	6mm [1/4"] STEEL 300MPa		Title		
			X-CABLE CHAIN SHELF - PROFILE CUT		
	Drawing Number		Process	Revision	
	10 60 215		P	B	

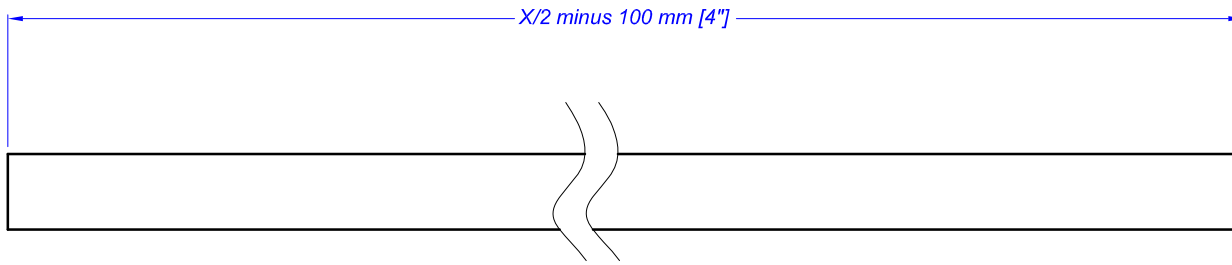
**MechMate**  
www.mechmate.com



Higher drawing/s:	10 60 210 W	1:1			
			First issue	06-11-07	A
			Description of change	Date (d-m-y)	Rev.
Material:	10mm [3/8"] STEEL ROD		Title		
			X-CABLE CHAIN SHELF ROD		
 <a href="http://www.mechmate.com">www.mechmate.com</a>		Drawing Number		Process	Revision
		10 60 217		S	A

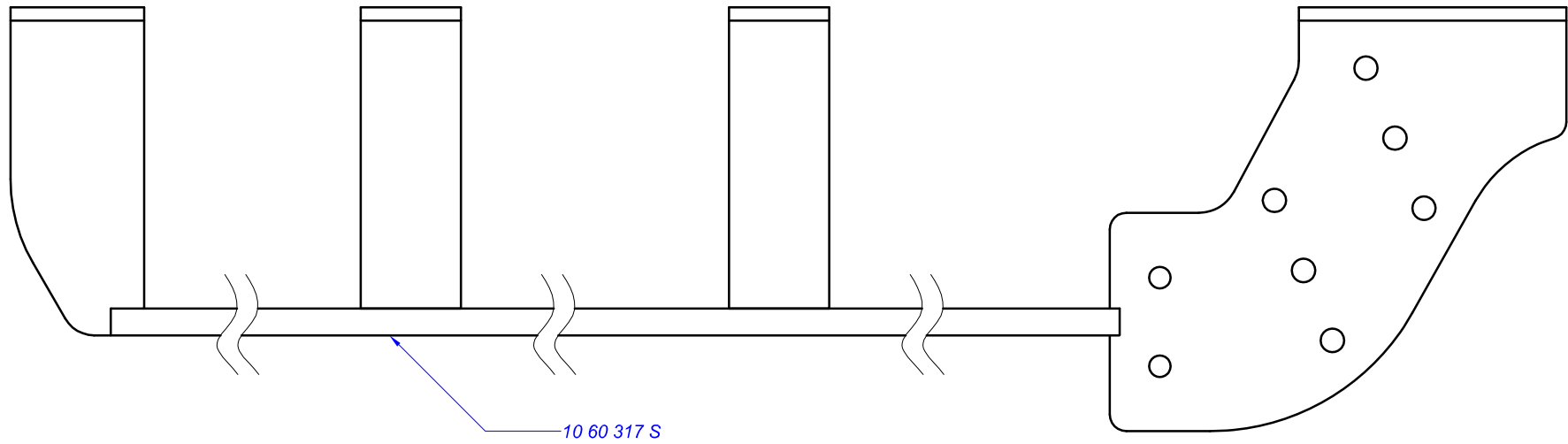
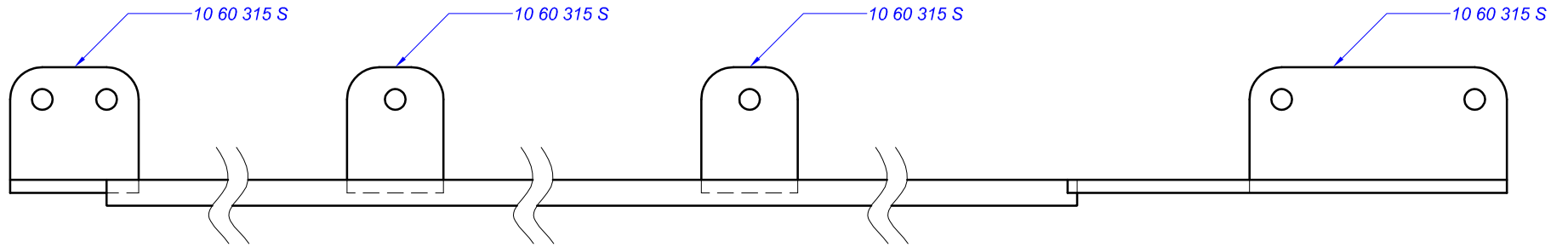

Higher drawing/s:	10 60 100 A	1:2		
			First issue	06-11-07 A
			Description of change	Date (d-m-y) Rev.
Material:	STEEL		Title	
			Y-CABLE CHAIN SHELF - WELD	
 www.mechmate.com		Drawing Number		Process
		10 60 310		W A

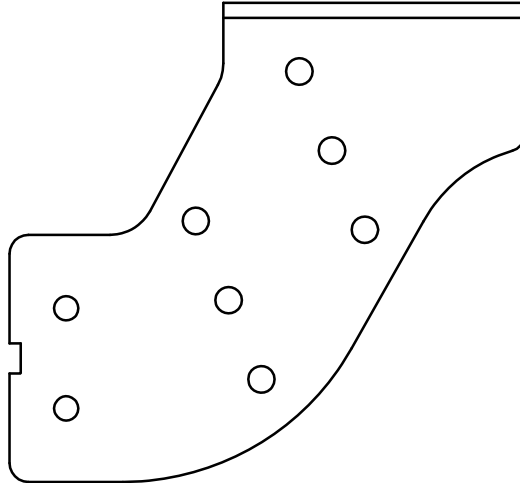
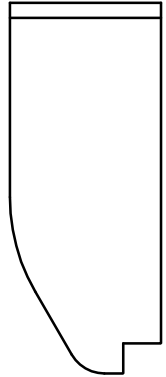
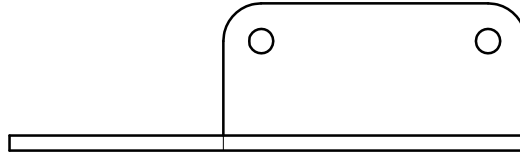
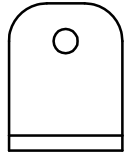
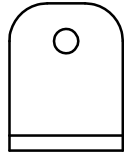
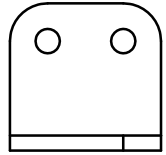

Higher drawing/s:	10 60 310 W	1:2			
			First issue	06-11-07	A
			Description of change	Date (d-m-y)	Rev.
Material:	4mm [3/16"] STEEL 300MPa	Title			
		Y-CABLE CHAIN SHELF - CUT			
www.mechmate.com		Drawing Number	Process	Revision	
		10 60 315	S	A	

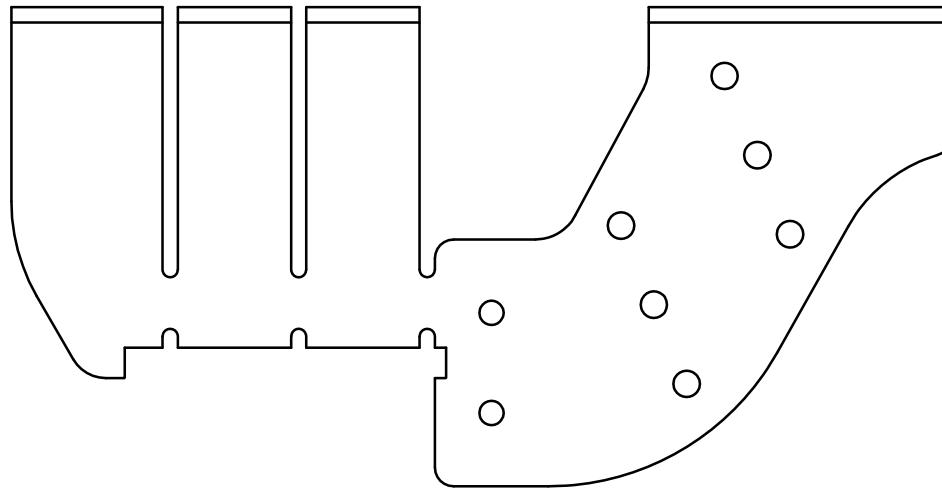
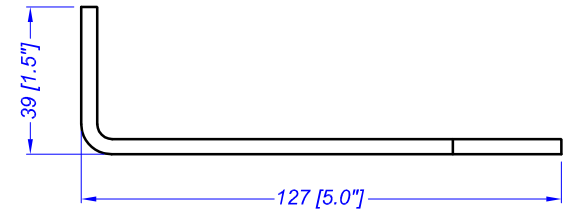
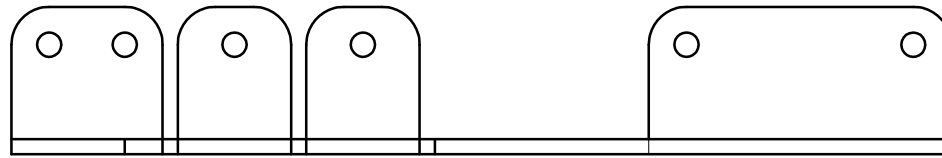

Developed part  $t = 4\text{mm}$  [3/16"]

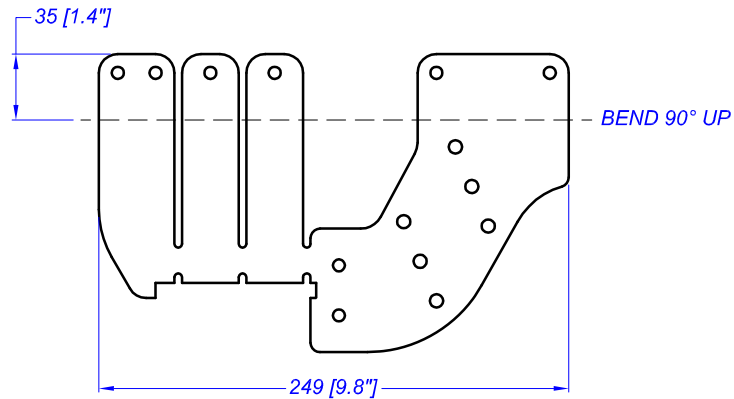



Higher drawing/s:	10 60 315 S	1:2		
			First issue	06-11-07 A
			Description of change	Date (d-m-y) Rev.
Material:	4mm [3/16"] STEEL 300MPa	Title		
MechMate www.mechmate.com		Y-CABLE CHAIN SHELF - BEND		
Drawing Number		Process	Revision	
10 60 315		B	A	

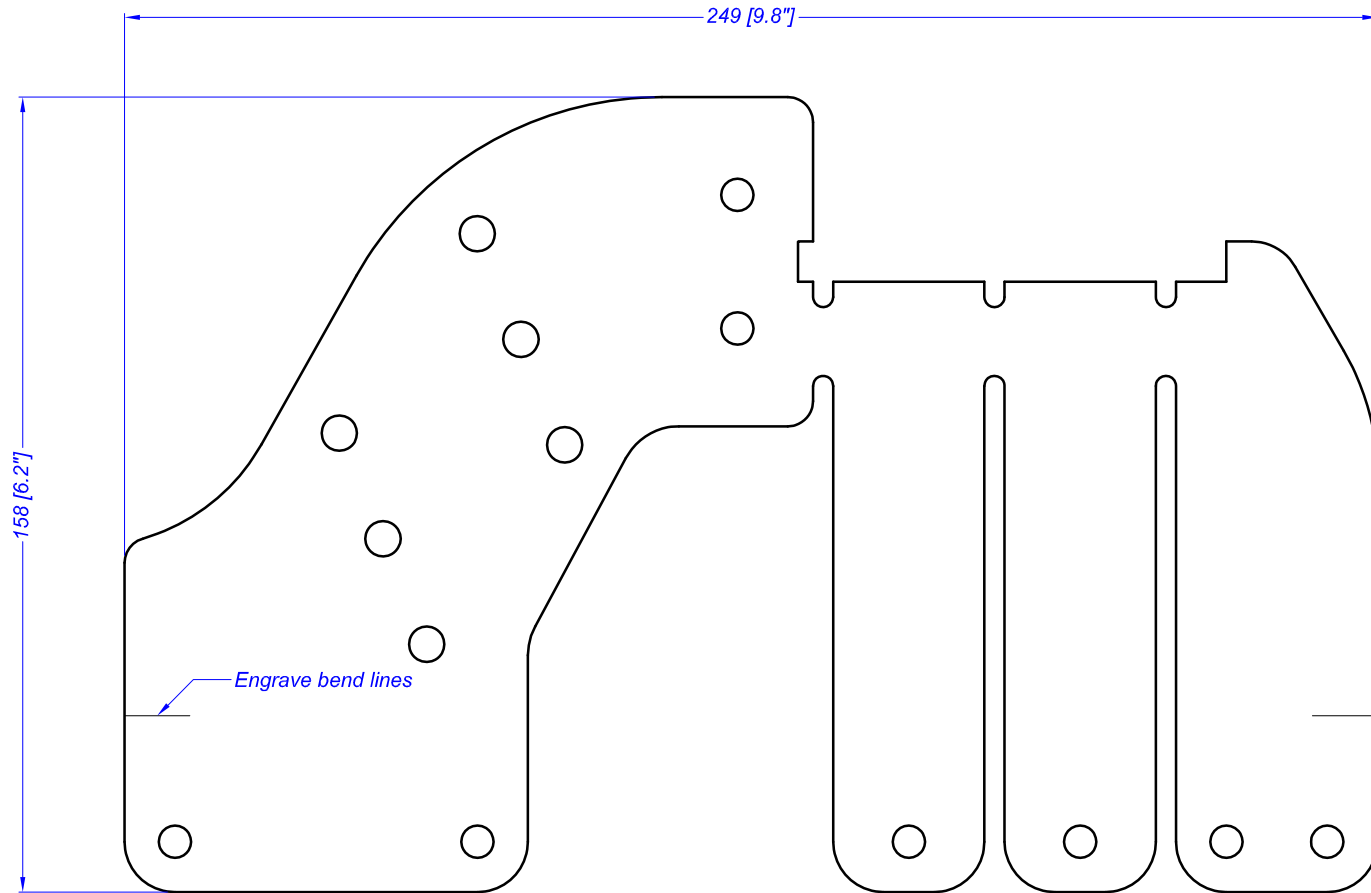

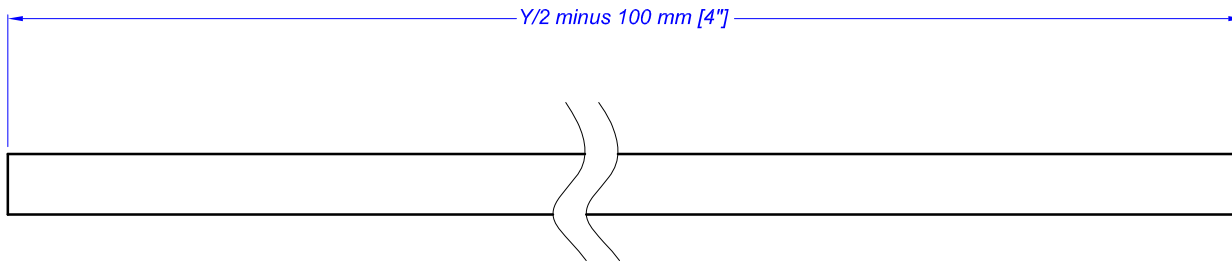

Higher drawing/s:	10 60 315 B	1:1.5			
			First issue	06-11-07	A
			Description of change	Date (d-m-y)	Rev.
Material:	4mm [3/16"] STEEL 300MPa	Title			
		Y-CABLE CHAIN SHELF - PROFILE CUT			
www.mechmate.com		Drawing Number		Process	Revision
		10 60 315		P	A



Higher drawing/s:	10 60 310 W	1:1			
			First issue	06-11-07	A
			Description of change	Date (d-m-y)	Rev.
Material:	8mm [5/16"] STEEL ROD		Title		
			Y-CABLE CHAIN SHELF ROD		
 <a href="http://www.mechmate.com">www.mechmate.com</a>		Drawing Number		Process	Revision
		10 60 317		S	A

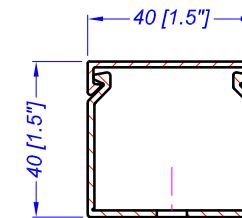
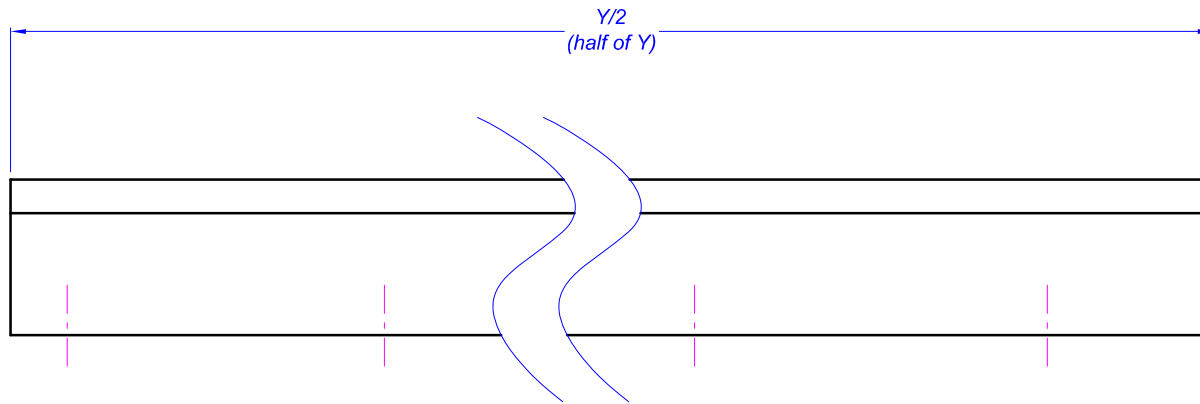

Drill Ø8mm holes at 250 to 300 centers

Higher drawing/s:	10 60 100 A	1:2			
			First issue	06-11-07	A
			Description of change	Date (d-m-y)	Rev.
Material:	40 x 40 mm PVC DUCT		Title		
			GANTRY CABLE DUCT		
 <a href="http://www.mechmate.com">www.mechmate.com</a>		Drawing Number		Process	Revision
		10 60 318		S	A

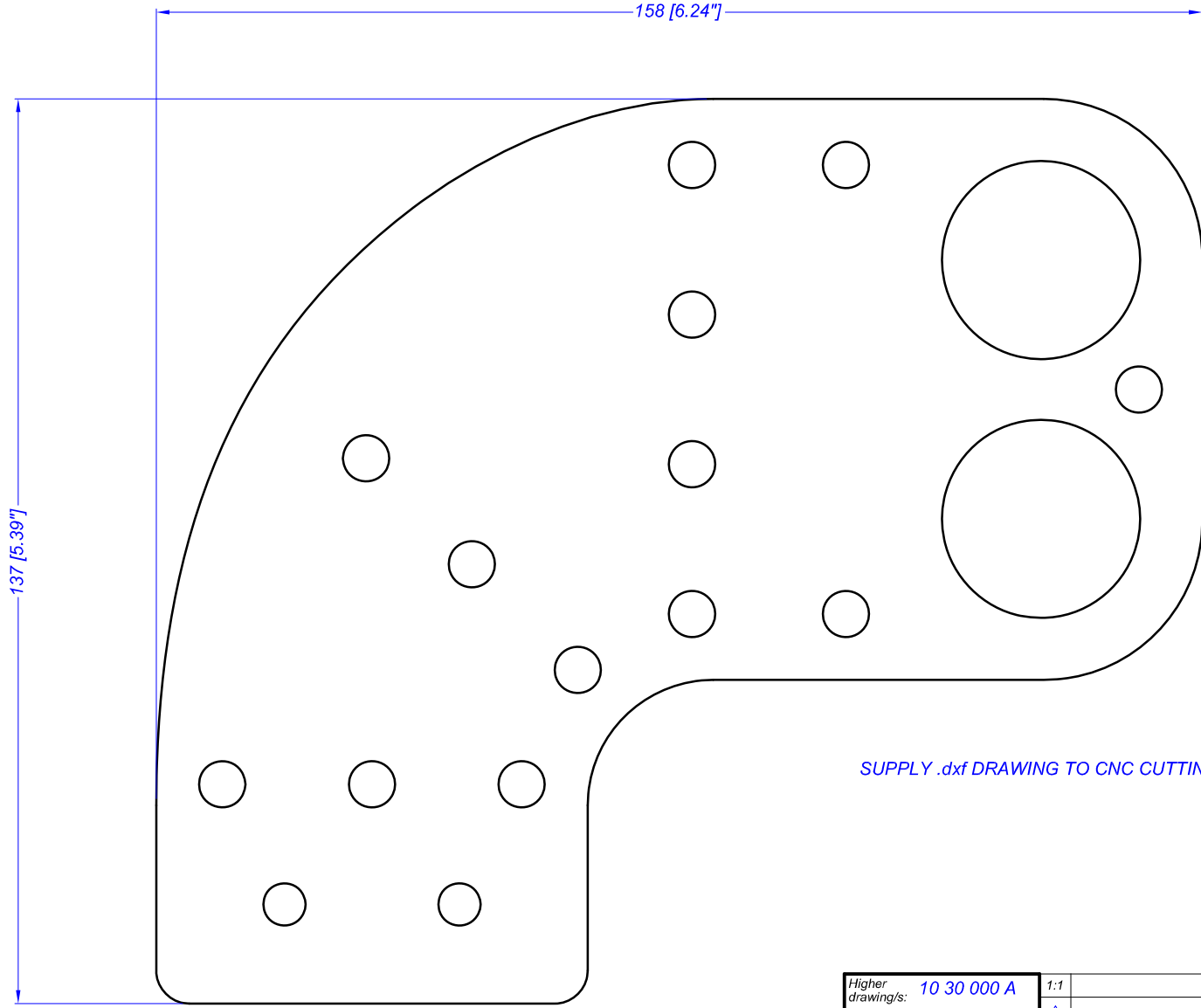

SUPPLY .dxf DRAWING TO CNC CUTTING COMPANY

Higher drawing/s:	10 30 000 A	1:1			
			First issue	25-09-07	A
			Description of change	Date (d-m-y)	Rev.
Material:	3mm [1/8"] STEEL 300MPa	Title			
 <a href="http://www.mechmate.com">www.mechmate.com</a>		Y-CAR CABLE CHAIN ANCHOR			
		Drawing Number	Process	Revision	
		10 60 325	P	A	