

SKF

SKF angular contact ball bearings - your key to longer service life



Contents

The SKF brand now stands for more than ever before, and means more to you as a valued customer.

While SKF maintains its leadership as the hallmark of quality bearings throughout the world, new dimensions in technical advances, product support and services have evolved SKF into a truly solutions-oriented supplier, creating greater value for customers.

These solutions encompass ways to bring greater productivity to customers, not only with breakthrough application-specific products, but also through leading-edge design simulation tools and consultancy services, plant asset efficiency maintenance programs, and the industry's most advanced supply management techniques.

The SKF brand still stands for the very best in rolling bearings, but it now stands for much more.

SKF – The knowledge engineering company



1 Product information 3

Diversity and quality 3

Why specify angular contact ball bearings? 3

Why specify SKF angular contact ball bearings? 3

Advantages by design with

SKF Explorer bearings 4

Technical improvements 4

Identification symbols 5

Advantages for your design:

higher performance with SKF Explorer bearings 6

Longer service life 6

New designs with smaller bearings 7

New designs with higher power density 7

Efficient in all industrial segments 8

2 Recommendations 10

Selection of bearing size 10

Bearing life 10

Load carrying capacity of paired
single row bearings 11

Equivalent dynamic bearing load 12

Equivalent static bearing load 12

Minimum load 12

Determining axial force for bearings
mounted singly or paired in tandem 13

Design of bearing arrangements 14

Mounting and dismounting 16

Mounting 16

Dismounting 17

Service for a lasting partnership 18

3 Product data 19

Single row angular contact ball bearings 19

General bearing data 19

Assortment 22

Product table 24

Double row angular contact ball bearings 34

General bearing data 34

Assortment 38

Product tables 40

Other SKF angular contact ball bearings 46

SKF – The knowledge engineering company 48

Diversity and quality

Why specify angular contact ball bearings?

High rotating speeds, combined radial and axial loads, a high degree of stiffness and running accuracy – these are the application requirements where angular contact ball bearings excel. The great variety of applications and operating conditions calls for unique bearing solutions made possible by a wide range of angular contact ball bearings.

Why specify SKF angular contact ball bearings?

Because SKF is your reliable, expert source for angular contact ball bearings. Because SKF has a wide range of types and variants unmatched anywhere else. Because when you work with SKF you don't have to settle for any unfavourable compromises. Since the introduction of the BE bearings in 1984, SKF single row angular contact ball bearings have set the standard. Since then, time certainly hasn't stood still, and neither has SKF.

The best example: the SKF Explorer single row and double row angular

contact ball bearings offer a completely new level of performance. With SKF angular contact ball bearings, you benefit in a number of ways:

High performance

They have a high load carrying capacity and thus allowing smaller bearings to be used while still providing long service life.

Quieter and cooler running

With their optimal internal geometry, they run quieter and cooler and can provide longer maintenance intervals.

Precise shaft guidance

Due to precision manufacturing processes, almost all SKF angular contacts meet closer tolerances, to enable a smoother, truer running shaft with less heat and less vibration.

High temperature capability

They can withstand relatively high operating temperatures without significant loss of dimensional stability.

Universal matching

At SKF, universally matchable single row angular contact ball bearings are standard. These bearings simplify assembly and can also increase the quality of your products. Our selection of clearance and preload classes covers almost all possible application requirements.

Integral sealing solutions

Double row angular contact ball bearings are available with integral seals and shields. These bearings are supplied with grease and do not require maintenance.

Standard solutions

It will be hard to find an application for which there's no standard SKF bearing readily available from our vast selection and enormous variety.

Customer satisfaction

Now you can build additional value into your products with SKF Explorer bearings. Your customers will definitely be impressed by the low operating costs, reliability and long service life of your machines – no doubt in part to your use of SKF bearings.



Advantages by design with SKF Explorer bearings

At SKF we're continuously working to improve the performance and durability of our products. And with the new SKF Explorer angular contact ball bearings, we think you'll notice the difference immediately. These bearings can provide:

- Even longer service life,
- Even higher reliability,
- Even more performance.

The following pages will describe the improvements we have made to our angular contact ball bearings in the 72 B and 73 B series and in the 32 A and 33 A series, of course also for the bearings in the 52 A and 53 A series, which are identical to the corresponding 32 A and 33 A bearings.

Technical improvements

Improved materials

SKF Explorer angular contact ball bearings are manufactured from an extremely high quality bearing steel with a very low oxygen content and a minimum number of impurities. The rings are manufactured from forged or cold rolled blanks.

All rings are heat treated to provide dimensional stability up to 150 °C (300 °F). The advantage: SKF single row angular contact ball bearing sets hold their original built-in clearances and preloads for extended operating times (→ **diagram 1**).

Improved inner geometry

Computer-aided design and manufacturing programs permit almost undetectable geometrical changes in the bearing. These small but effective changes in the bearing's geometry lead to measurable improvements in performance and service life. One effect of this fine tuning: SKF Explorer

angular contact ball bearings are less sensitive to potential axial overloading.

More precise shaft guidance

SKF Explorer single row bearings are manufactured to P5 running accuracy. SKF Explorer double row bearings are manufactured to P6 running accuracy.

Better ball quality

The balls used in SKF Explorer angular contact ball bearings are one ISO grade better than before. The more uniform ball diameter helps to improve running accuracy even at high speeds, while reducing noise and operating temperature.

New cages

SKF Explorer single row angular contact ball bearings have solid cages made from polyamide or brass. Polyamide cages have been improved

Diagram 1

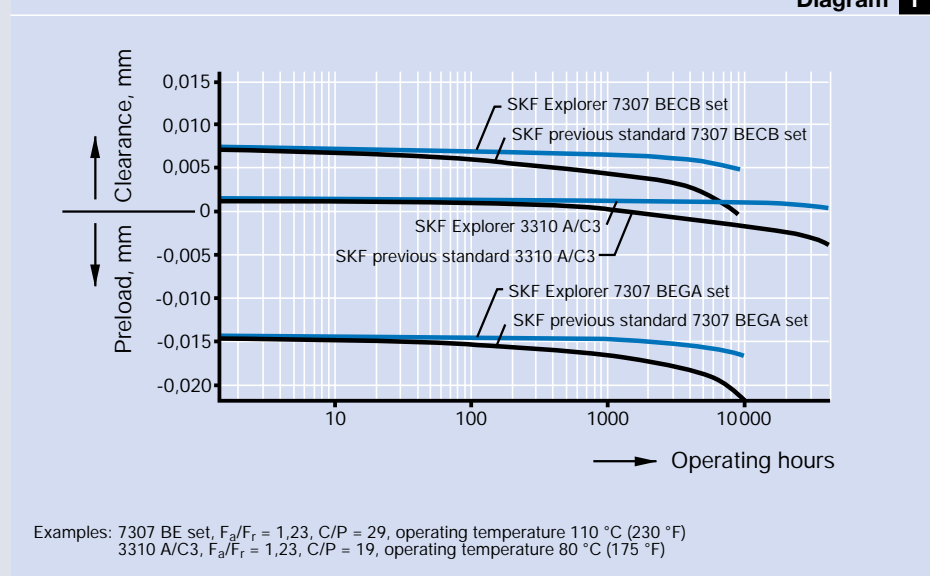

Change of the residual axial bearing clearance/preload during operation





Fig 1

Shielded SKF Explorer double row angular contact ball bearing

to better withstand high accelerations. Machined brass cages are manufactured to closer tolerances and have been improved to provide better ball guidance and maximize the effects of the lubricant under all operating conditions.

SKF Explorer double row angular contact ball bearings are available as standard with a newly-developed crown cage made of sheet steel.

Effective seals

Double row angular contact ball bearings are available with seals or shields. Shielded SKF Explorer bearings (→ fig 1) use a new shield design. A new simple labyrinth keeps contaminants out and retains grease in the bearing cavity.

Identification symbols

SKF Explorer angular contact ball bearings are not an extension of the assortment. They replace final variants of the previous types. And because it is easier for inventory management,

SKF Explorer angular contact ball bearings

- Improved materials
- Optimized internal geometry
- Higher precision
- Higher ball quality
- Improved cages
- For universal matching in bearing sets
- New shields for double row bearings

their part numbers remain the same. Nevertheless, SKF Explorer bearings can be recognised easily.

Packaging

SKF Explorer bearings come in a unique package, so that they can be recognised immediately as SKF Explorer bearings.

Laser inscription

A new feature of the SKF Explorer bearings is their laser inscription. It is not only more legible, but also more environmentally friendly because acids are no longer required for etching. It also permits individual markings. Depending on the requirements in Quality Assurance, the bearings can be traced precisely.



Advantages for your design: higher performance with SKF Explorer bearings

The technical improvements incorporated in SKF Explorer angular contact ball bearings can provide one of four general design benefits. For existing designs, you can either increase service life or increase power output. For new designs, you can maintain power output or increase power density. The option you chose depends on the customer and the application's requirements. Whichever option you chose, new SKF Explorer angular contact ball bearings will provide increased service

life and decreased maintenance costs for your application.

Longer service life

The extended life of SKF Explorer angular contact ball bearings can be demonstrated best with the use of an example. The shafts of a twin screw compressor are supported radially with cylindrical roller bearings and axially with a matched set of angular con-

tact ball bearings (→ fig 1). With the existing design, the axial bearing of the drive shaft is the critical point. The calculated life of this bearing arrangement, consisting of three 7308 BEGAP bearings amounts to 50 900 hours; calculated in accordance with the SKF Life Method. With the new SKF Explorer bearings, the calculated life amounts to 96 200 hours. This means a life 1,9 times longer under otherwise identical conditions and without any changes in the design.

Increase service life of existing designs

Don't need to increase power output? Use an SKF Explorer bearing of equal size to:

- Increase the reliability
- Reduce vibration
- Reduce heat generation
- Increase service intervals
- Increase machine uptime

Maintain power output of new designs

Use a smaller SKF Explorer bearing to:

- Reduce overall dimensions to save on material cost and weight
- Reduce heat generation
- Increase speeds

Increase power output of existing designs

Avoid costly redesign by using an SKF Explorer bearing of equal size to:

- Increase power density (output)
- Increase speeds
- Increase loads

Increase power density of new designs

Use a lower cross section SKF Explorer bearing with the same outside diameter to:

- Increase shaft size
- Achieve a stiffer design
- Operate at the same or higher speeds

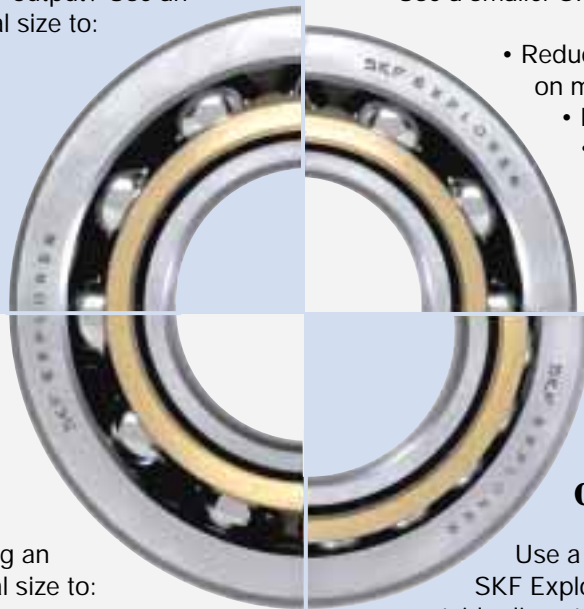

New designs with smaller bearings













In many cases where 73 B series bearings are used, it will be possible to use 72 B series bearings in the future. Even with a smaller bearing, a longer bearing service life will be possible. **Table 1** shows some suitable examples.

Without changes to the shaft, bearing arrangements can also be designed more compactly. SKF Explorer bearings permit lighter structures with the same capacity.

New designs with higher power density

If the outside diameter of the bearing remains unchanged, the transition from 73 B series bearings to 72 B series bearings will permit the use of stronger shafts (→ **table 1**).

With otherwise unchanged parts, more rigid designs with higher power density are possible. And the service life of the bearing will be increased significantly.

Table 1				
	Previous standard bearing	SKF Explorer bearing	Cross section $\frac{A_{Expl.}}{A_{prev.}} \times 100$	Life increase $\frac{L_{10m,Expl.}}{L_{10m,prev}}$
Same bore diameter	7306 BE 	7206 BE 	64 %	1
	7308 BE 	7208 BE 	63 %	1,2
	7319 BE 	7219 BE 	51 %	1,1
Same outer diameter	7304 BE 	7205 BE 	84 %	1,7
	7308 BE 	7210 BE 	70 %	1,6
	7313 BE 	7216 BE 	63 %	1,5

Comparison of SKF Explorer and previous standard bearings – possible downsizing

Twin-screw compressor bearing arrangement

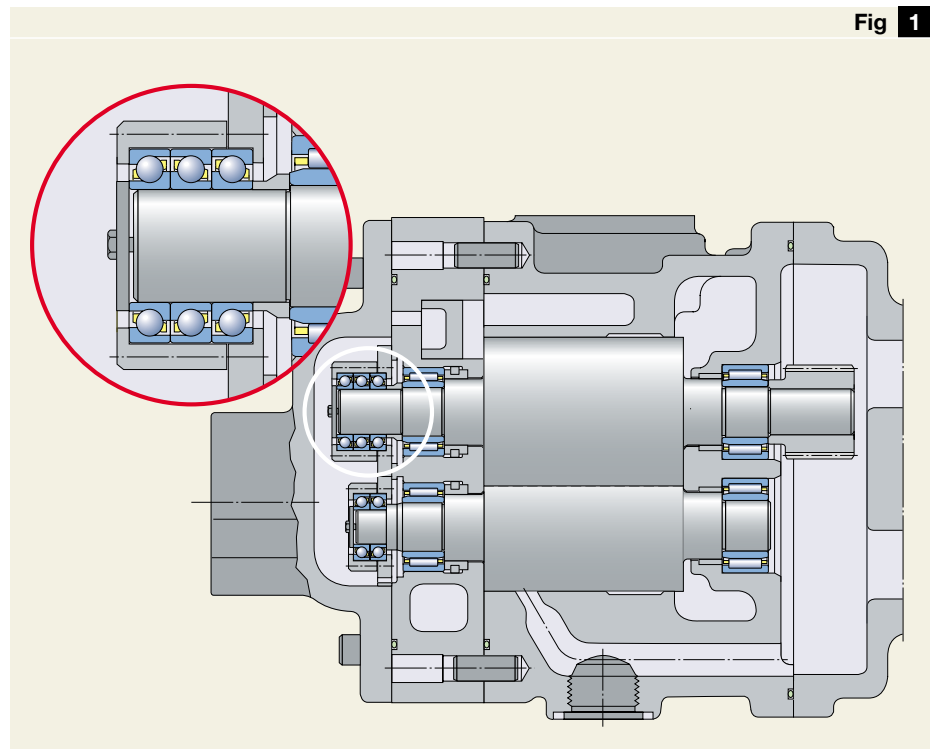

Fig 1

Efficient in all industrial segments

Lower friction, quieter running and, above all, improved reliability in complex applications with combined loads make SKF angular contact ball bearings indispensable in many areas.

Long service life and reliable performance have earned SKF angular contact ball bearings an excellent reputation in a variety of industries ranging from gearboxes to turbines.

Nevertheless, the most common applications for angular contact ball bearings are pumps and compressors. These applications are not just the most common, they are also the most demanding. For example, the bearings

used in both pumps and compressors must be able to accommodate combined axial and radial loads, high speeds, poor lubrication and contaminated conditions.

The improvements made to the new SKF Explorer bearings were aimed primarily at the demanding requirements of both pumps and compressors. For these applications a recommended product range is available.

Industrial segments

- Fluid machinery:
Pumps, compressors, blowers, ventilators, turbines
- Automotive engineering:
Drives, clutches, gearboxes, wheel bearings, components
- Industrial drives and drive motors
- Printing machines
- Textile machines
- Material handling

Requirements

- Long service life
- High load-carrying capacity and high speeds
- High degree of stiffness
- High degree of running accuracy
- Low heat generation
- Quiet running
- Technical support

Solution





Selection of bearing size

Bearing life

The life-extending improvements, embodied in SKF Explorer bearings can best be understood using the SKF Life Method. This life calculation method constitutes an extension of the fatigue life theory developed by Lundberg and Palmgren and is better able to predict bearing life. The life method, first presented by SKF in 1989 is standardized today in ISO 281:1990/Amd 2:2000. The modified rating life for angular contact ball bearings can be calculated from

$$L_{nm} = a_1 a_{SKF} L_{10}$$

or

$$L_{nm} = a_1 a_{SKF} \left(\frac{C}{P}\right)^3$$

With a constant rotational speed, the life in operating hours can be calculated from the following formula:

$$L_{nmh} = a_1 a_{SKF} \frac{1\,000\,000}{60 n} \left(\frac{C}{P}\right)^3$$

where

- L_{nm} = SKF rating life (at 100 – n % reliability), millions of revolutions
- L_{nmh} = SKF rating life (at 100 – n % reliability), operating hours
- L_{10} = basic rating life (at 90 % reliability), millions of revolutions
- a_1 = life adjustment factor for reliability (→ table 1)
- a_{SKF} = SKF life modification factor (→ diagram 1)
- C = basic dynamic load rating, kN
- P = equivalent dynamic bearing load, kN
- n = rotational speed, r/min

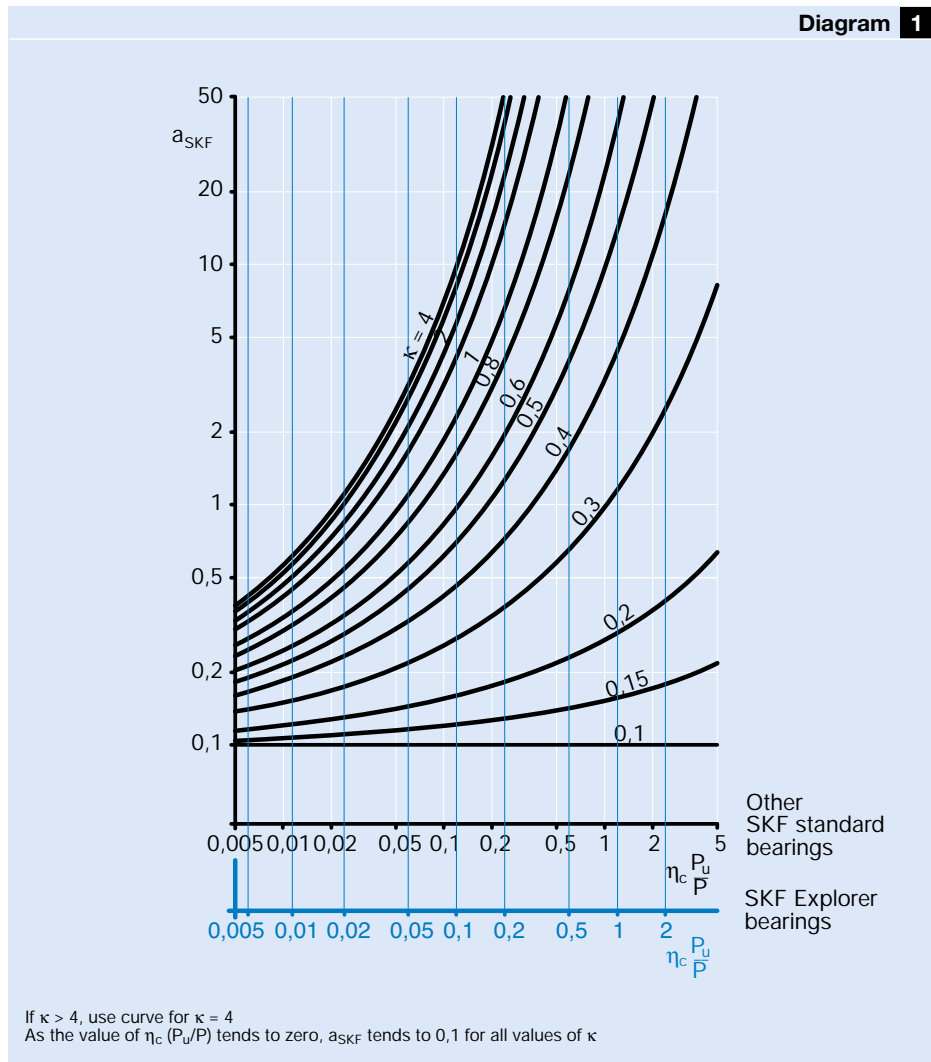

Life modification factor a_{SKF} for angular contact ball bearings

Table 1

Reliability %	L_{nm}	a_1
90	L_{10m}	1
95	L_{5m}	0,62
96	L_{4m}	0,53
97	L_{3m}	0,44
98	L_{2m}	0,33
99	L_{1m}	0,21

Values for life adjustment factor a_1

Bearing life can be calculated easily using the programs found in the "SKF Interactive Engineering Catalogue".

Life modification factor a_{SKF}

The SKF Life Method takes into account the complex relationships between different factors influencing bearing life. These factors have been simplified so that they can be inserted into your calculations. **Diagram 1** contains the life modification factor for SKF angular contact ball bearings. The values are given as a function of

- the viscosity ratio κ ,
- the ratio of the fatigue load limit to the applied equivalent load (P_u/P),
- the contamination level in the bearing (η_c).

Guideline values for the selection of η_c are given in **table 2**.

Diagram 1 is based on the general safety factors typically associated with the fatigue load limits for other mechanical components. The diagram is valid for lubricants without EP additives. If lubricants with EP additives are used, reference should be made to the information in the SKF General Catalogue or in the "SKF Interactive Engineering Catalogue" on CD-ROM or online at www.skf.com.

Load carrying capacity of paired single row bearings

The values for the basic dynamic and static load ratings as well as for the fatigue load limit quoted in the bearing table on **pages 24 to 33** are for single bearings.

For pairs of universally matchable angular contact ball bearings the basic dynamic load ratings C obtained from the table should be multiplied by

- 1,62 for standard bearings in all arrangements and SKF Explorer bearings in face-to-face or back-to-back arrangement,
- 2 for SKF Explorer bearings in tandem arrangement.

Condition	Factor η_c ¹⁾ for bearings with diameter	
	$d_m < 100$ mm	$d_m \geq 100$ mm
Extreme cleanliness Particle size of the order of the lubricant film thickness. Laboratory conditions	1	1
High cleanliness Oil filtered through extremely fine filter Conditions typical of bearings greased for life and sealed	0,8 ... 0,6	0,9 ... 0,8
Normal cleanliness Oil filtered through fine filter Conditions typical of bearings greased for life and shielded	0,6 ... 0,5	0,8 ... 0,6
Slight contamination Slight contamination in lubricant	0,5 ... 0,3	0,6 ... 0,4
Typical contamination Conditions typical of bearings without integral seals, coarse filtering, wear particles and ingress from surroundings	0,3 ... 0,1	0,4 ... 0,2
Severe contamination Bearing environment heavily contaminated and bearing arrangement with inadequate sealing	0,1 ... 0	0,1 ... 0
Very severe contamination (under extreme contamination values of η_c can be outside the scale resulting in a more severe reduction of life than predicted by the equation for L_{nm})	0	0

¹⁾ The scale for η_c refers only to typical solid contaminants. Contamination by water or other fluids detrimental to bearing life is not included. In case of very heavy contamination ($\eta_c = 0$), failure will be caused by wear, the useful life of the bearing can be shorter than the rated life

Guideline values for factor η_c for different levels of contamination

The basic static load rating and the fatigue load limit of a pair of bearings can be obtained by multiplying the table value C_0 or P_u by 2.

Equivalent dynamic bearing load

Single row bearings

For single row B and BE design angular contact ball bearings mounted as single bearings or paired in tandem:

$$P = F_r \quad \text{when } F_a/F_r \leq 1,14$$

$$P = 0,35 F_r + 0,57 F_a \quad \text{when } F_a/F_r > 1,14$$

When determining the axial load F_a , reference should be made to the section "Determining axial force for bearings mounted singly or paired in tandem".

For pairs of bearings arranged back-to-back or face-to-face:

$$P = F_r + 0,55 F_a \quad \text{when } F_a/F_r \leq 1,14$$

$$P = 0,57 F_r + 0,93 F_a \quad \text{when } F_a/F_r > 1,14$$

F_r and F_a are the forces acting on the pair of bearings.

Double row bearings

For double row angular contact ball bearings in the 32 A and 33 A series:

$$P = F_r + 0,78 F_a \quad \text{when } F_a/F_r \leq 0,80$$

$$P = 0,63 F_r + 1,24 F_a \quad \text{when } F_a/F_r > 0,80$$

and for double row angular contact ball bearings in the 33 DNRCBM series:

$$P = F_r + 0,55 F_a \quad \text{when } F_a/F_r \leq 1,14$$

$$P = 0,57 F_r + 0,93 F_a \quad \text{when } F_a/F_r > 1,14$$

and for double row angular contact ball bearings in the 33 D series:

$$P = F_r + 0,47 F_a \quad \text{when } F_a/F_r \leq 1,34$$

$$P = 0,54 F_r + 0,81 F_a \quad \text{when } F_a/F_r > 1,34$$

Equivalent static bearing load

Single row bearings

For single row B and BE design angular contact ball bearings mounted as single bearings or paired in tandem:

$$P_0 = 0,5 F_r + 0,26 F_a$$

If $P_0 < F_r$ then $P_0 = F_r$. When determining the axial load F_a , refer to the section "Determining axial force for

Bearing size

bearings mounted singly or paired in tandem".

For pairs of bearings arranged back-to-back or face-to-face:

$$P_0 = F_r + 0,52 F_a$$

F_r and F_a are the forces acting on the pair of bearings.

Double row bearings

For double row angular contact ball bearings in the 32 A and 33 A series:

$$P_0 = F_r + 0,66 F_a$$

and for bearings in the 33 DNRCBM series:

$$P_0 = F_r + 0,52 F_a$$

and for bearings in the 33 D series:

$$P_0 = F_r + 0,44 F_a$$

Minimum load

In order to provide satisfactory operation, a minimum load must be applied to the bearing arrangement. This is particularly important in high-speed applications where inertial forces of the balls and the cage as well as the friction in the lubricant influence the rolling conditions in the bearing to cause sliding movements (skidding) between the balls and raceways.

For single row individual bearings and pairs of bearings in a tandem arrangement, the requisite minimum load can be calculated as follows:

$$F_{am} = k_a \frac{C_0}{1\,000} \left(\frac{n d_m}{100\,000} \right)^2$$

For pairs of bearings arranged back-to-back or face-to-face as well as for double row bearings, the following applies:

$$F_{rm} = k_r \left(\frac{v n}{1\,000} \right)^{2/3} \times \left(\frac{d_m}{100} \right)^2$$

where

F_{am} = minimum axial load, kN

F_{rm} = minimum radial load, kN

C_0 = basic static load rating of bearing or bearing pair respectively, kN

k_a = minimum axial load factor according to **table 3**

k_r = minimum radial load factor according to **table 3**

v = oil viscosity at operating temperature, mm²/s

n = rotational speed, r/min

d_m = mean diameter of bearing = 0,5 (d + D), mm

As a rule, the load is already higher than the necessary minimum load through the weight of the parts supported and the external forces. If the calculated minimum load is not obtained, the bearing must be loaded additionally in other ways. In the case of individual bearings or pairs of bearings in a tandem arrangement, an additional axial load can be achieved by adjusting the inner and outer ring or with the use of springs. Double row bearings as well as bearing sets arranged back-to-back or face-to-face can also be loaded radially.

Minimum load factors

Table 3

Bearing series	Minimum load factors	
	k_a	k_r
72 BE	1,4	0,095
72 B	1,2	0,08
73 BE	1,6	0,1
73 B	1,4	0,09
32 A	–	0,06
33 A	–	0,07
33 D	–	0,095
33 DNR	–	0,095

Determining axial force for bearings mounted singly or paired in tandem

When a radial load is applied, the load is transmitted from one raceway to the other at an angle to the bearing axis and an internal axial force will be induced in single row angular contact ball bearings. This must be considered when calculating the equivalent bearing loads for bearing arrangements consisting of two single bearings and/or bearing pairs arranged in tandem.

The necessary equations are given in **table 4** for the various bearing arrangements and load cases. The equations are only valid if the bearings are adjusted against each other to practically zero clearance, but without any preload. In the arrangements shown, bearing A is subjected to a radial load F_{rA} and bearing B to a radial load F_{rB} . Both F_{rA} and F_{rB} are always considered positive even when they act in the direction opposite to that shown in the figures. The radial loads act at the pressure centres of the bearings (\rightarrow dimension a in the product table).

Variable R

The variable R from **table 4** takes into account the contact conditions inside the bearing. The values for R can be obtained from **diagram 2** as a function of the ratio K_a/C . K_a is the external axial load acting on the shaft or on the housing and C is the basic dynamic load rating of the bearing, which must accommodate the external axial load. For $K_a = 0$ use $R = 1$.

Values for variable R

Table 4			
Bearing arrangement	Load case	Axial forces	
	Case 1a $F_{rA} \geq F_{rB}$ $K_a \geq 0$	$F_{aA} = R F_{rA}$ $F_{aB} = F_{aA} + K_a$	
	Case 1b $F_{rA} < F_{rB}$ $K_a \geq R (F_{rB} - F_{rA})$	$F_{aA} = R F_{rA}$ $F_{aB} = F_{aA} + K_a$	
	Case 1c $F_{rA} < F_{rB}$ $K_a < R (F_{rB} - F_{rA})$	$F_{aA} = F_{aB} - K_a$ $F_{aB} = R F_{rB}$	
		Case 2a $F_{rA} \leq F_{rB}$ $K_a \geq 0$	$F_{aA} = F_{aB} + K_a$ $F_{aB} = R F_{rB}$
		Case 2b $F_{rA} > F_{rB}$ $K_a \geq R (F_{rA} - F_{rB})$	$F_{aA} = F_{aB} + K_a$ $F_{aB} = R F_{rB}$
		Case 2c $F_{rA} > F_{rB}$ $K_a < R (F_{rA} - F_{rB})$	$F_{aA} = R F_{rA}$ $F_{aB} = F_{aA} - K_a$

Axial loading of bearing arrangements incorporating two single row B or BE design angular contact ball bearings and/or bearing pairs in tandem

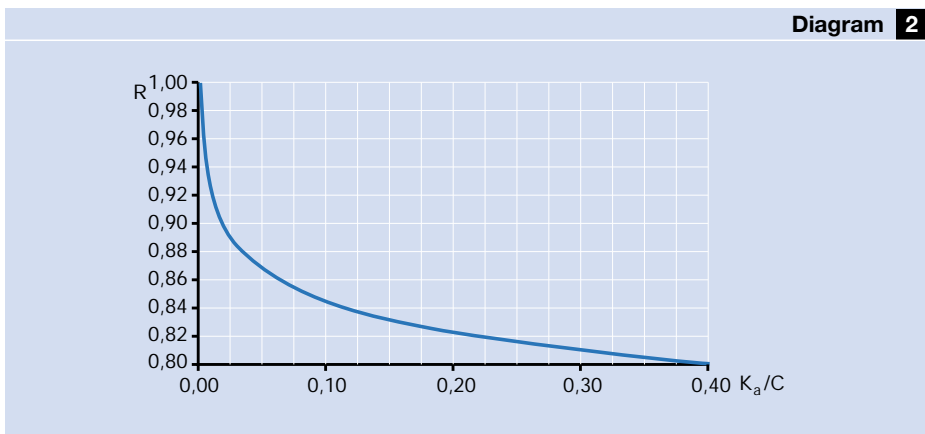

Design of bearing arrangements

Adjusting single row angular contact ball bearings

Because of their internal design, angular contact ball bearings should not be used alone and should always be used with a second bearing or as part of a bearing set (→ **figs 1** and **2**).

In cases where there are two individual single row angular contact ball bearings, they should be adjusted against each other until the desired internal clearance or the necessary preload is obtained.

Adjusting clearance or preload correctly is one of the most important factors that affects bearing service life and the reliability of the bearing arrangement (→ **diagram 1**). In the case of excessive clearance, the load carrying capacity of the bearings will not be realized. This will cause excessive noise or skidding between the balls and raceways. In the case of excessive preload, higher friction and the resulting higher operating temperatures will reduce bearing service life.

Single row angular contact ball bearings as bearing sets

Paired mounting is used when the load carrying capacity is inadequate (tandem arrangement) or when combined or axial loads act in both directions (back-to-back and face-to-face arrangements).

When arranged in tandem (→ **fig 3a**), the radial and axial loads are shared equally by the bearings. However the bearing set can only accommodate axial loads acting in one direction. Axial loads acting in both directions, as well as combined loads, require a third bearing adjusted against the tandem pair.

Bearings arranged back-to-back (→ **fig 3b**) can accommodate axial loads acting in both directions, but only by one bearing in each direction. Bearings mounted back-to-back provide a relatively stiff bearing arrangement, which can accommodate tilting moments.

Bearings mounted face-to-face (→ **fig 3c**) can accommodate axial loads acting in both directions, but only by one bearing in each direction.

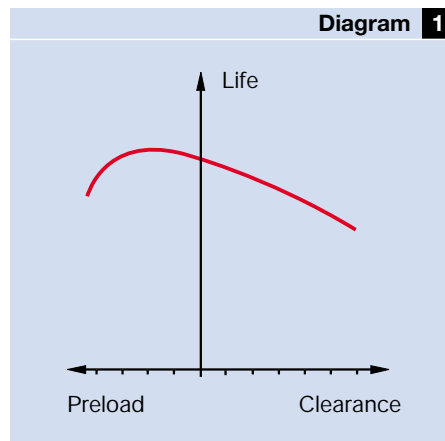

Bearing service life as a function of clearance or preload

Bearing arrangement with two individual bearings

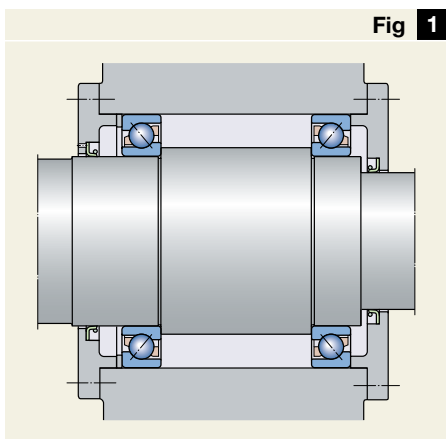

Bearing arrangement with a bearing set

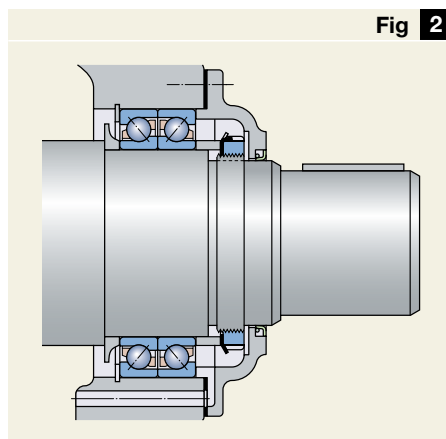

Arrangement combinations of universally matchable bearings

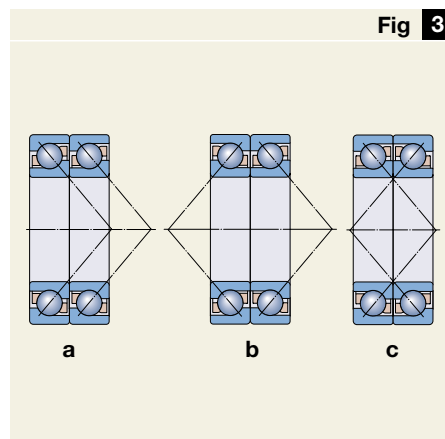

This arrangement is not as stiff as the back-to-back arrangement and is less able to accommodate tilting moments.

Bearing sets that use universally matchable SKF bearings do not need special shims or final adjustments. These bearings are supplied with the correct preload or clearance manufactured into the bearing. To realize these predetermined values, the bearing seat in the housing and on the shaft must be manufactured to the correct tolerances.

Favourable load ratios for single row angular contact ball bearings

For single row angular contact ball bearings with a 40° contact angle (designation suffix B), the optimal rolling conditions will only be achieved in the bearing when the load ratio $F_a/F_r \geq 1$.

Axial loads acting in one direction

In applications where single row bearings are mounted back-to-back or face-to-face, axial loads acting predominantly in one direction can increase noise, cause the balls to skid,

interrupt the lubricant film or increase cage loads in the axially inactive bearing.

To correct this condition, bearings with zero clearance or a light preload are typically used. For additional information, contact your local SKF application engineering service.

Double row bearings with shields or seals

Bearings with shields are typically used in applications where the inner ring rotates. In applications where the outer ring rotates, grease (at certain speeds) can exit between the shield and the outer ring.

Under extreme conditions, where there are high speeds or high operating temperatures, grease can escape between the inner ring and seal.

Cage selection criteria

Angular contact ball bearings are available with different cages. The characteristics of the cages and selection criteria are summarised in **table 1**.

For more information on cages that are typically used in bearings for high-speed applications, contact your local SKF representative.

Cage characteristics and selection chart

Table 1

Characteristics	Cage design						
	Injection moulded polyamide	Pressed steel conventional	Pressed steel crowned	Machined steel	Pressed brass	Machined brass	
Suffixes	P or TN9	J or none	J or none	F	Y	M	MA
Cage guidance	ball	ball	ball	ball	ball	ball	outer ring shoulder
Sliding properties of guiding surfaces	++	0	+	+	0	+	+
Lubricant access	++	0	++	+	0	+	– (grease) + (oil)
Weight	++	+	+	–	+	–	0
Elasticity	++	0	0	–	0	–	–
Strength	–	0	0	++	0	++	+
Suitability for							
high acceleration	0	–	0	–	–	+	++
high temperatures	0	+	+	++	+	++	++
vibration	0	–	0	+	–	+	++
high speed	0	–	0	0 (grease) + (oil)	0	+	++

++ very favourable + favourable 0 average – unfavourable

Mounting and dismounting

Mounting

Angular contact ball bearings are usually mounted with an interference fit onto the shaft. Bearings up to a 50 mm diameter bore can usually be mounted mechanically. But it is not possible to mount larger bearings when they are "cold", as the force required to mount the bearing increases considerably with its size. Therefore, the bearings should be heated prior to mounting.

When mounting, a clean work environment is essential since dirt introduced into the bearing will dramatically affect the bearing service life. In principle, bearings should always remain in the original packing until immediately before mounting.

Mechanical mounting

- Oil the bearing seating surface lightly with thin oil.
- Press the bearing on at right angles to the shaft axis.
- Apply force to the bearing ring that needs to be mounted with interference (→ fig 1).

SKF TMFT bearing fitting tools are designed for quick, precise and safe mounting of smaller sized bearings.

Hot mounting

- Heat the bearing with an induction heater (→ fig 2) or a hotplate. SKF TIH series induction heaters provide high quality heating power and control and provide excellent automatic demagnetisation.
- The required temperature difference between the bearing inner ring and shaft seating depends on the magnitude of the interference fit and the bearing size. Normally a bearing temperature of 80 to 90 °C (175 to 195 °F) above that of the shaft is sufficient for mounting. Never heat a bearing to a temperature above 125 °C (255 °F).

- Wear clean protective gloves when mounting a hot bearing. Push the bearing along the shaft as far as the abutment and hold the bearing in position, pressing until a tight fit is obtained.
- Sealed bearings should be heated only with an induction heater and should never be heated above 80 °C (175 °F).

After mounting

- Check whether the outer ring can be turned without resistance.
- Secure the bearing onto the shaft or in the housing.
- Angular contact ball bearings usually operate at high speeds. Therefore, grease should fill only about 30 % of the free space in the bearing cavity.

Apply force to the bearing ring that needs to be mounted with interference

Induction heater for bearings

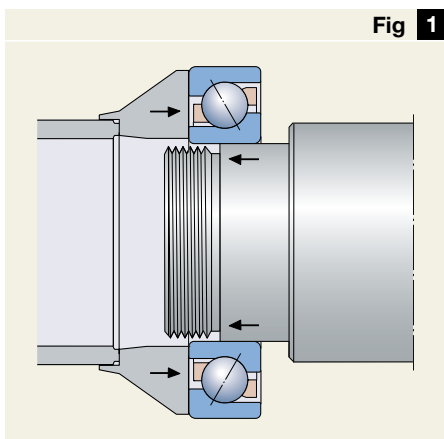

Fig 1

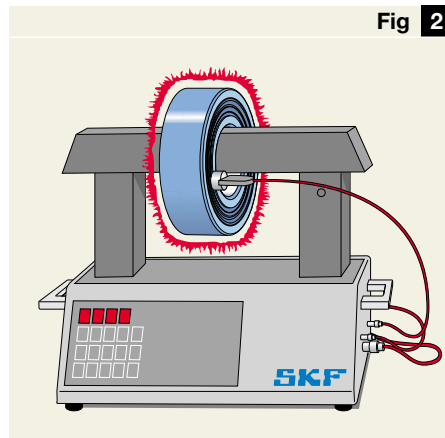

Fig 2

Dismounting

Dismounting is a potential source of bearing damage. Dirt may enter the bearing or errors may be made during remounting. Therefore avoid, if possible, dismantling an undamaged bearing.

When dismantling a bearing, arrange for a suitable stop or support for the shaft, otherwise the bearing might be damaged by dismantling forces.

Cleanliness is very important. It is easier to prevent bearings from becoming dirty than it is to clean them. Most angular contact ball bearings can not be separated and are therefore difficult to clean.

An undamaged bearing should be remounted in the same position in the housing. Mark the relative position of each bearing, i. e. which section of the bearing is up, which side is front etc.

Dismounting

Removing bearings from the shaft

- Always use a puller. SKF offers a comprehensive assortment of suitable pullers.
- Place the claws of the puller against the side face of the inner ring (→ **fig 3**).
- To avoid damage to the bearing seat, the puller should be accurately centred. The use of a self-centring puller is highly recommended and makes dismantling faster and easier.
- Only in cases, where it is impossible to engage the inner ring, should the claws of the puller be applied to the outer ring. Rotate the outer ring when dismantling so that no part of the bearing is damaged by the dismantling force. To do this lock the screw and rotate the puller continuously until the bearing comes free (→ **fig 4**).

Note: Do not engage the puller to the low shoulder of a single row angular contact ball bearing (→ **fig 5**).



Detailed mounting instructions for almost all SKF rolling bearings are available online at www.skf.com/mount

Always place the claws of the puller at the inner ring

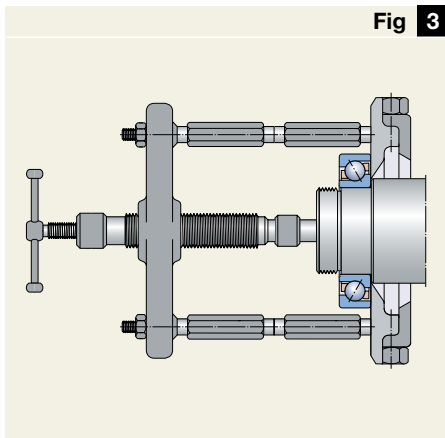

Only in exceptional cases apply the claws of the puller to the outer ring

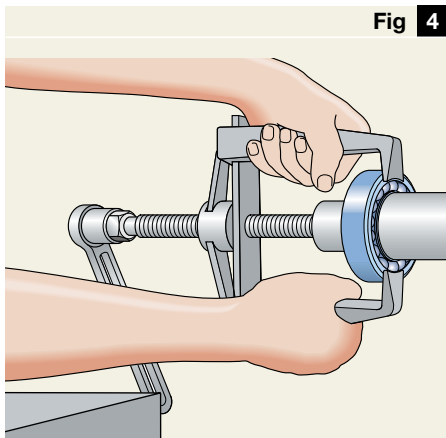

Never engage the puller at the side of the low shoulder of the bearing outer ring

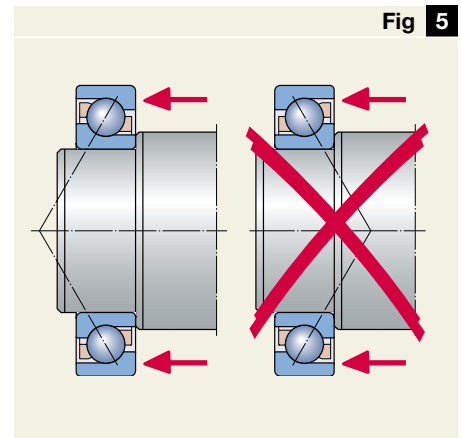

Service for a lasting partnership

Under the proper conditions, bearings can run for an extremely long time. For them to run at least as long as they should, operating conditions must be optimized. At SKF we know our bearings and you know your operating conditions. Together, as partners SKF can work with you during the design stage and continue to work with you right through to installation and maintenance to keep your machines in peak operating condition.

SKF concepts for creating customer value

Why not take advantage of SKF competencies for creating customer value? Decades of troubleshooting experience in virtually every industrial sector

enables SKF to provide solutions that improve machine performance and productivity. With our Total Shaft Solutions™ concept you can take full advantage of our in-depth competence comprising

- Root cause failure analysis and elimination
- Rotating equipment engineering
- Products, services and systems
- Machine monitoring

Another SKF concept that embraces a broader view of customer-focused technologies and competencies is called Asset Efficiency Optimization™, or AEO for short. As the name implies, AEO recognizes the importance of

treating machinery and equipment as plant assets. SKF programs that take a systems approach to optimizing these customer assets include

- Predictive Maintenance,
- Pro-active Reliability Maintenance
- Operator-driven Reliability, and
- Integrated Maintenance Solutions, an all-inclusive contractual program.

For more information about SKF competencies and services, contact your local SKF representative.



Single row angular contact ball bearings

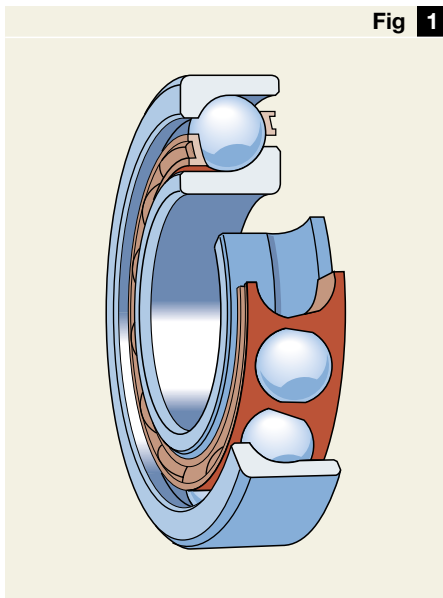

Fig 1

General bearing data

Designs

Only bearings in the 72 B and 73 B series (→ fig 1) are shown in this brochure. For information about other single row angular contact ball bearings, please refer to the “SKF Interactive Engineering Catalogue” on CD-ROM or online at www.skf.com. SKF bearings in the 72 B and 73 B series have a 40° contact angle (→ fig 2) and are designed to be non-separable. Two versions are available:

- Bearings for universal matching in sets. These bearings are designed for arrangements where two or more bearings are mounted immediately adjacent to each other in random order.
- Basic design bearings. These bearings are intended for arrangements where only one bearing is used at each bearing position.

Universally matchable bearings are precision manufactured so that a specific clearance or preload is “built into” the bearings when mounted immediately adjacent to each other. This precision manufacturing process also provides an even distribution of load, without the use of shims or similar devices.

Tables 3 and 4 on pages 22 and 23 indicate which bearing versions are available in the standard assortment as individual bearings or as universally matchable bearings. All SKF Explorer bearings are universally matchable. All universally matchable bearings can also be used as single bearings.

Dimensions

The boundary dimensions of SKF single row angular contact ball bearings conform to ISO 15:1998.

Tolerances

Basic design bearings for single mounting are manufactured to Normal tolerances. Standard design bearings for universal matching are manufactured to better tolerances than Normal.

SKF Explorer bearings are manufactured to P6 dimensional accuracy, P5 running accuracy and are universally matchable.

The values of the tolerances correspond to ISO 492:2002.

Clearance, preload

In applications where individual bearings are used, the clearance or preload is determined by adjusting one bearing against another during installation.

Universally matchable bearings mounted in a back-to-back or face-to-face arrangement, have the prescribed clearance or preload “built into” the bearings and do not require any adjustment during mounting.

Universally matchable bearings are available in different internal clearance or preload classes. Bearings with Normal clearance (CB) or light preload (GA) are standard. Tables 3 and 4 on pages 22 and 23 show the available standard options. For additional information about special internal clearances or preloads, contact your local SKF representative.

Two or more universally matchable bearings with axial internal clearance CA, CB or CC can be mounted immediately adjacent to each other in random order. However bearings with preload GA, GB and GC should only be arranged in pairs, as otherwise the preload will increase.

40° contact angle

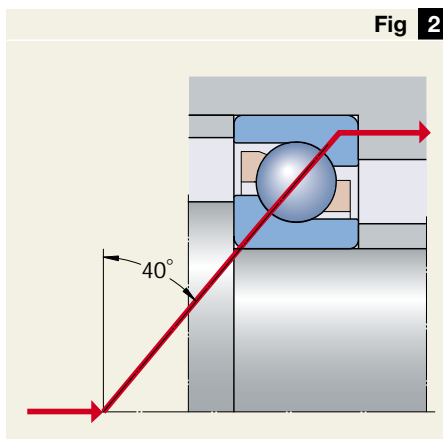

Fig 2

Values for the axial internal clearance classes CA, CB and CC are given in **table 1**. They are valid for bearings arranged back-to-back or face-to-face, before mounting and under zero measuring load.

The values for the preload classes GA, GB and GC are given in **table 2** and apply to bearing pairs in a back-to-back or face-to-face arrangement before mounting.

Speed ratings for bearing pairs

For bearings arranged in pairs, the reference speeds provided in the product table for single bearings should be reduced by approximately 20 %.

Misalignment

Single row angular contact ball bearings have only limited ability to accommodate misalignment. The permissible misalignment of the shaft relative to the housing depends on the operating clearance in the bearing, bearing size, internal design and the forces and moments acting on the bearing. Because of the complex relationship between the influencing factors, it is not possible to quote any values which are universally valid.

However, under normal operating conditions the value of the permissible misalignment for individual bearings lies between 2 and 6 minutes of arc.

For bearings mounted in sets, particularly those with small axial internal clearance when mounted in a back-to-back arrangement, angular misalignments can only be accommodated between the balls and raceways by force. This leads to increased ball loads and cage stresses as well as a reduction in bearing service life. Any misalignment of the bearing rings will also lead to an increase in running noise.

Cages

Depending on size and series, SKF single row angular contact ball bearings are equipped as standard with one of the cages described below. The available SKF standard assortment is shown in **tables 3** and **4** on **pages 22** and **23**.

The standard cages used for single row angular contact ball bearings are

Table 1

Bore diameter d over incl.		Axial internal clearance					
		Class CA		Class CB		Class CC	
mm	incl.	min	max	min	max	min	max
		μm					
10	18	5	13	15	23	24	32
18	30	7	15	18	26	32	40
30	50	9	17	22	30	40	48
50	80	11	23	26	38	48	60
80	110	14	26	32	44	55	67
110	180	17	29	35	47	62	74
180	250	21	37	45	61	74	90

Axial internal clearance of sets of universally matchable bearings arranged back-to-back or face-to-face (before mounting and under zero measuring load)

Table 2

Bore diameter d over incl.		Preload class										
		Class GA			Class GB			Class GC				
mm	incl.	min	max	max	min	max	min	max	min	max	min	max
		μm		N	μm		N		μm		N	
10	18	+4	-4	80	-2	-10	30	330	-8	-16	230	660
18	30	+4	-4	120	-2	-10	40	480	-8	-16	340	970
30	50	+4	-4	160	-2	-10	60	630	-8	-16	450	1 280
50	80	+6	-6	380	-3	-15	140	1 500	-12	-24	1 080	3 050
80	110	+6	-6	410	-3	-15	150	1 600	-12	-24	1 150	3 250
110	180	+6	-6	540	-3	-15	200	2 150	-12	-24	1 500	4 300
180	250	+8	-8	940	-4	-20	330	3 700	-16	-32	2 650	7 500

Preload of bearing pairs consisting of universally matchable bearings arranged back-to-back or face-to-face (before mounting)

- an injection moulded cage of glass fibre reinforced polyamide 6,6 (→ **fig 3**), ball centred, designation suffix P,
- a pressed window-type brass cage (→ **fig 4**), ball centred, designation suffix Y,
- a machined window-type brass cage (→ **fig 5**), ball centred, designation suffix M.

Bearings having a pressed sheet steel cage, designation suffix J, or machined steel cage, designation suffix F, may also be available. Before ordering, please check for availability.

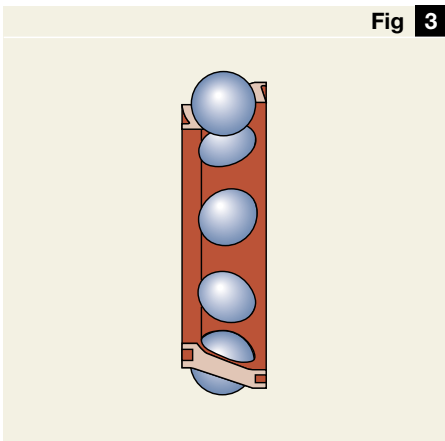

Polyamide cage

Fig 3

Note

Single row angular contact ball bearings with polyamide 6,6 cages can be used at temperatures up to +120 °C (250 °F). With the exception of a few oils and greases with a synthetic oil base, and lubricants containing a high proportion of EP additives when used at high temperatures, the lubricants generally used for rolling bearings do not have a detrimental effect on cage properties.

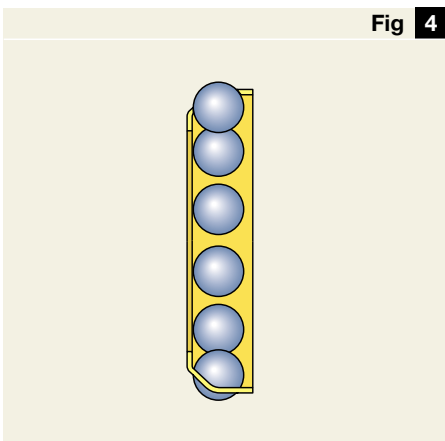

Pressed brass cage

Fig 4

Designation suffixes

The designation suffixes used to identify certain features of SKF single row angular contact ball bearings are explained in the following.

- A** 30° contact angle
- AC** 25° contact angle
- B** 40° contact angle
- CA** Bearing for universal matching mounted in random order; when arranged back-to-back or face-to-face the axial internal clearance will be smaller than Normal (CB)
- CB** Bearing for universal matching mounted in random order; when arranged back-to-back or face-to-face the axial internal clearance will be Normal
- CC** Bearing for universal matching mounted in random order; when arranged back-to-back or face-to-face the axial internal clearance will be greater than Normal (CB)
- DB** Two bearings matched back-to-back
- DF** Two bearings matched face-to-face
- DT** Two bearings matched in tandem
- E** Optimized internal design
- F** Machined steel cage
- GA** Bearing for universal matching mounted in random order; when arranged back-to-back or face-to-face there will be a light preload

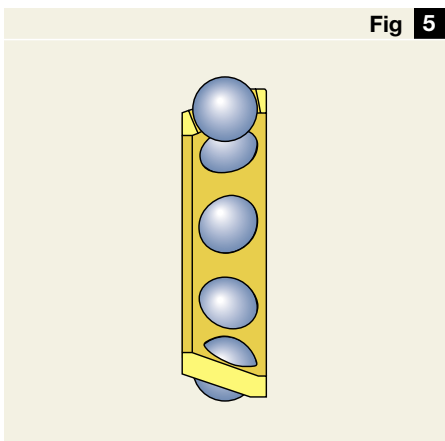

Machined brass cage

Fig 5

- GB** Bearing for universal matching mounted in random order; when arranged back-to-back or face-to-face there will be a moderate preload
- GC** Bearing for universal matching mounted in random order; when arranged back-to-back or face-to-face there will be a heavy preload
- J** Pressed steel cage, ball centred
- M** Machined brass cage, ball centred, different designs are identified by a figure, e.g. M1
- N1** One locating slot in the outer ring
- N2** Two locating slots in the outer ring, positioned at 180° to each other
- P** Injection moulded cage of glass fibre reinforced polyamide 6,6, ball centred
- P5** Dimensional and running accuracy to ISO tolerance class 5
- P6** Dimensional and running accuracy to ISO tolerance class 6
- W64** Solid Oil filling
- Y** Pressed window-type brass cage, ball centred

Assortment

SKF single row angular contact ball bearings in the 72 B and 73 B series are available in a number of variants. The standard assortment for bearings in the

- 72 B series is listed in **table 3** and
- 73 B series is listed in **table 4**.

The dimensions and performance data of these bearings can be found in the product table starting on **page 24**.

Additional variants with other internal clearance or preload values or different cage variations are available. For details, contact your local SKF representative.

Bearing designations

Tables 3 and **4** also contain the bearing designations of the bearings available in the standard assortment. The table headings show bearing designations without the size code; a grey coloured square indicates the position for the size.

Example of an order designation

A universally matchable bearing in the 73 BE series



- with a 60 mm bore diameter (bearing size 12),
- with Normal axial internal clearance when arranged back-to-back or face-to-face as bearing pair (CB),
- with a cage of glass fibre reinforced polyamide 6,6 (P)

has 7312 BECBP as order designation. The meaning of relevant designation suffixes is explained on **page 21**.

When ordering universally matchable bearings it is necessary to state the number of individual bearings required – not the number of pairs.

Table **3**



Bore diameter mm	Universally matchable bearings						Basic design bearings			Bearing size	
	72 BECBP	72 BEGAP	72 BEGBP	72 BECXY	72 BEGAY	72 B(E)CBM	72 B(E)GAM	72 BEP	72 BEY		72 B(E)M
10											00
12											01
15											02
17											03
20											04
25											05
30											06
35											07
40											08
45											09
50											10
55											11
60											12
65											13
70											14
75											15
80											16
85											17
90											18
95											19
100											20
105											21
110											22
120											24
130											26
140											28
150											30
160											32
170											34
180											36
190											38
200											40
220											44
240											48

 SKF Explorer bearing
 Other SKF standard bearing

SKF standard assortment of single row angular contact ball bearings in the 72 B series

Table 4

Bore diameter mm	Universally matchable bearings				Basic design bearings				Bearing size					
	73 BECAP	73 BECBP	73 BEGAP	73 BEGBP	73 BECXY	73 BEGBY	73 B(E)CBM	73 BECCM		73 BEGAM	73 B(E)GBM	73 BEP	73 BEY	73 B(E)M
10														00
12														01
15														02
17														03
20														04
25														05
30														06
35														07
40														08
45														09
50														10
55														11
60														12
65														13
70														14
75														15
80														16
85														17
90														18
95														19
100														20
105														21
110														22
120														24
130														26
140														28
150														30
160														32
170														34
180														36
190														38
200														40
220														44
240														48

 SKF Explorer bearing
 Other SKF standard bearing

SKF standard assortment of single row angular contact ball bearings in the 73 B series

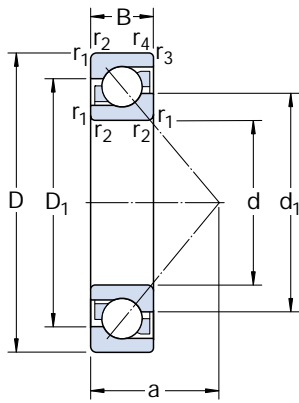

Principal dimensions			Basic load ratings		Fatigue load limit P _u	Speed ratings		Mass	Designations*	
d	D	B	dynamic C	static C ₀		Reference speed	Limiting speed		Universally matchable bearing	Basic design bearing
mm			kN		kN	r/min		kg	-	
10	30	9	7,02	3,35	0,14	30 000	30 000	0,030	7200 BECBP	7200 BEP
12	32	10	7,61	3,8	0,16	26 000	26 000	0,036	7201 BECBP	7201 BEP
	37	12	10,6	5	0,208	24 000	24 000	0,063	-	7301 BEP
15	35	11	8,84	4,8	0,204	24 000	24 000	0,045	7202 BECBP	7202 BEP
	42	13	13	6,7	0,28	20 000	20 000	0,081	7302 BECBP	7302 BEP
17	40	12	11	5,85	0,25	22 000	22 000	0,064	7203 BECBP	-
	40	12	10,4	5,5	0,236	20 000	20 000	0,064	-	7203 BEP
	40	12	11,1	6,1	0,26	20 000	20 000	0,064	-	7203 BEY
	40	12	11	5,85	0,25	22 000	22 000	0,070	7203 BECBM	-
	47	14	15,9	8,3	0,355	19 000	19 000	0,11	7303 BECBP	7303 BEP
20	47	14	14	8,3	0,355	18 000	18 000	0,11	7204 BECBP	7204 BEP
	47	14	14	8,3	0,355	18 000	18 000	0,11	7204 BECBY	-
	47	14	13,3	7,65	0,325	18 000	19 000	0,11	7204 BECBM	-
	52	15	19	10	0,425	18 000	18 000	0,14	7304 BECBP	-
	52	15	17,4	9,5	0,4	16 000	16 000	0,14	-	7304 BEP
	52	15	19	10,4	0,44	16 000	16 000	0,15	7304 BECBY	7304 BEY
	52	15	19	10	0,425	18 000	18 000	0,15	7304 BECBM	-
25	52	15	15,6	10	0,43	17 000	17 000	0,13	7205 BECBP	-
	52	15	14,8	9,3	0,4	15 000	15 000	0,13	-	7205 BEP
	52	15	15,6	10,2	0,43	15 000	15 000	0,13	7205 BECBY	7205 BEY
	52	15	15,6	10	0,43	17 000	17 000	0,14	7205 BECBM	-
	62	17	26,5	15,3	0,655	15 000	15 000	0,23	7305 BECBP	-
	62	17	24,2	14	0,6	14 000	14 000	0,23	-	7305 BEP
	62	17	26	15,6	0,655	14 000	14 000	0,24	7305 BECBY	7305 BEY
	62	17	26,5	15,3	0,655	15 000	15 000	0,24	7305 BECBM	-
30	62	16	24	15,6	0,655	14 000	14 000	0,19	7206 BECBP	-
	62	16	22,5	14,3	0,61	13 000	13 000	0,19	-	7206 BEP
	62	16	23,8	15,6	0,655	13 000	13 000	0,21	7206 BECBY	7206 BEY
	62	16	24	15,6	0,655	14 000	14 000	0,21	7206 BECBM	-
	72	19	35,5	21,2	0,9	13 000	13 000	0,33	7306 BECBP	-
	72	19	32,5	19,3	0,815	12 000	12 000	0,33	-	7306 BEP
	72	19	34,5	21,2	0,9	12 000	12 000	0,37	7306 BECBY	7306 BEY
	72	19	35,5	21,2	0,9	13 000	13 000	0,37	7306 BECBM	-
35	72	17	31	20,8	0,88	12 000	12 000	0,28	7207 BECBP	-
	72	17	29,1	19	0,815	11 000	11 000	0,28	-	7207 BEP
	72	17	30,7	20,8	0,88	11 000	11 000	0,30	7207 BECBY	7207 BEY
	72	17	31	20,8	0,88	12 000	12 000	0,30	7207 BECBM	-
	80	21	41,5	26,5	1,14	11 000	11 000	0,45	7307 BECBP	-
	80	21	39	24,5	1,04	10 000	10 000	0,45	-	7307 BEP
	80	21	39	24,5	1,04	10 000	10 000	0,49	7307 BECBY	7307 BEY
	80	21	41,5	26,5	1,14	11 000	11 000	0,49	7307 BECBM	-

* The designations of bearings belonging to the SKF Explorer performance class are printed blue. Information on available variants → pages 22 and 23

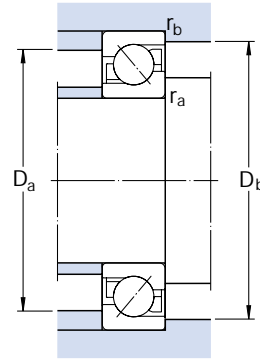
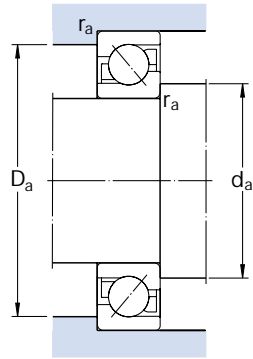

Conversion factors:

Length: 1 mm = 0,0394 in
 1 in = 25,4 mm
Force: 1 N = 0,225 lbf
 1 lbf = 4,4482 N
Mass: 1 kg = 2,205 lb
 1 lb = 0,454 kg

Dimensions

Abutment and fillet dimensions

d	d ₁ ~	d ₂ ~	D ₁ ~	r _{1,2} min	r _{3,4} min	a	d _a min	D _a max	D _b max	r _a max	r _b max
mm	mm										
10	18,3	14,6	22,9	0,6	0,3	13	14,2	25,8	27,6	0,6	0,3
12	20,2 21,8	16,6 17	25 28,3	0,6 1	0,3 0,6	14,4 16,3	16,2 17,6	27,8 31,4	29,6 32,8	0,6 1	0,3 0,6
15	22,7 26	19 20,7	27,8 32,6	0,6 1	0,3 0,6	16 18,6	19,2 20,6	30,8 36,4	32,6 37,8	0,6 1	0,3 0,6
17	26,3 26,3 26,3 26,3 28,7	21,7 21,7 21,7 21,7 22,8	31,2 31,2 31,2 31,2 36,2	0,6 0,6 0,6 0,6 1	0,6 0,6 0,6 0,6 0,6	18 18 18 18 20,4	21,2 21,2 21,2 21,2 22,6	35,8 35,8 35,8 35,8 41,4	35,8 35,8 35,8 35,8 42,8	0,6 0,6 0,6 0,6 1	0,6 0,6 0,6 0,6 0,6
20	30,8 30,8 30,8 33,3 33,3 33,3 33,3	25,9 25,9 25,9 26,8 26,8 26,8 26,8	37 37 37 40,4 40,4 40,4 40,4	1 1 1 1,1 1,1 1,1 1,1	0,6 0,6 0,6 0,6 0,6 0,6 0,6	21 21 21 22,8 22,8 22,8 22,8	25,6 25,6 25,6 27 27 27 27	41,4 41,4 41,4 45 45 45 45	42,8 42,8 42,8 47,8 47,8 47,8 47,8	1 1 1 1 1 1 1	0,6 0,6 0,6 0,6 0,6 0,6 0,6
25	36,1 36,1 36,1 36,1 39,8 39,8 39,8 39,8	30,9 30,9 30,9 30,9 32,4 32,4 32,4 32,4	41,5 41,5 41,5 41,5 48,1 48,1 48,1 48,1	1 1 1 1 1,1 1,1 1,1 1,1	0,6 0,6 0,6 0,6 0,6 0,6 0,6 0,6	23,7 23,7 23,7 23,7 26,8 26,8 26,8 26,8	30,6 30,6 30,6 30,6 32 32 32 32	46,4 46,4 46,4 46,4 55 55 55 55	47,8 47,8 47,8 47,8 57,8 57,8 57,8 57,8	1 1 1 1 1 1 1 1	0,6 0,6 0,6 0,6 0,6 0,6 0,6 0,6
30	42,7 42,7 42,7 42,7 46,6 46,6 46,6 46,6	36,1 36,1 36,1 36,1 37,9 37,9 37,9 37,9	50,1 50,1 50,1 50,1 56,5 56,5 56,5 56,5	1 1 1 1 1,1 1,1 1,1 1,1	0,6 0,6 0,6 0,6 0,6 0,6 0,6 0,6	27,3 27,3 27,3 27,3 31 31 31 31	35,6 35,6 35,6 35,6 37 37 37 37	56,4 56,4 56,4 56,4 65 65 65 65	57,8 57,8 57,8 57,8 67,8 67,8 67,8 67,8	1 1 1 1 1 1 1 1	0,6 0,6 0,6 0,6 0,6 0,6 0,6 0,6
35	49,7 49,7 49,7 49,7 52,8 52,8 52,8 52,8	42 42 42 42 43,6 43,6 43,6 43,6	58,3 58,3 58,3 58,3 63,3 63,3 63,3 63,3	1,1 1,1 1,1 1,1 1,5 1,5 1,5 1,5	0,6 0,6 0,6 0,6 1 1 1 1	31 31 31 31 35 35 35 35	42 42 42 42 44 44 44 44	65 65 65 65 71 71 71 71	67,8 67,8 67,8 67,8 74,4 74,4 74,4 74,4	1 1 1 1 1,5 1,5 1,5 1,5	0,6 0,6 0,6 0,6 1 1 1 1

Single row angular contact ball bearings
d 40 – 60 mm

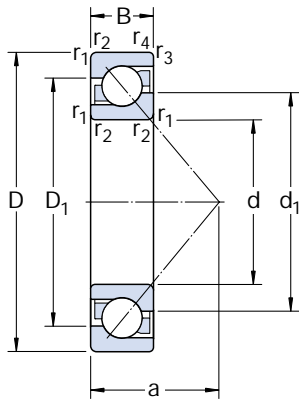

Principal dimensions			Basic load ratings		Fatigue load limit P _u	Speed ratings		Mass	Designations*	
d	D	B	dynamic C	static C ₀		Reference speed	Limiting speed		Universally matchable bearing	Basic design bearing
mm			kN		kN	r/min		kg	-	
40	80	18	36,5	26	1,1	11 000	11 000	0,37	7208 BECBP	-
	80	18	34,5	24	1,02	10 000	10 000	0,37	-	7208 BEP
	80	18	36,4	26	1,1	10 000	10 000	0,38	7208 BEC BY	7208 BEY
	80	18	36,5	26	1,1	11 000	11 000	0,39	7208 BECBM	-
	80	18	34,5	24	1,02	10 000	10 000	0,39	-	7208 BEM
	90	23	50	32,5	1,37	10 000	10 000	0,61	7308 BECBP	-
	90	23	46,2	30,5	1,13	9 000	9 000	0,61	-	7308 BEP
	90	23	49,4	33,5	1,4	9 000	9 000	0,64	7308 BEC BY	7308 BEY
	90	23	50	32,5	1,37	10 000	10 000	0,68	7308 BECBM	-
45	85	19	38	28,5	1,22	10 000	10 000	0,42	7209 BECBP	-
	85	19	35,8	26	1,12	9 000	9 000	0,42	-	7209 BEP
	85	19	37,7	28	1,2	9 000	9 000	0,43	7209 BEC BY	7209 BEY
	85	19	38	28,5	1,22	10 000	10 000	0,44	7209 BECBM	-
	100	25	61	40,5	1,73	9 000	9 000	0,82	7309 BECBP	-
	100	25	55,9	37,5	1,73	8 000	8 000	0,82	-	7309 BEP
	100	25	60,5	41,5	1,73	8 000	8 000	0,86	7309 BEC BY	7309 BEY
	100	25	61	40,5	1,73	9 000	9 000	0,90	7309 BECBM	-
	50	90	20	40	31	1,32	9 000	9 000	0,47	7210 BECBP
90		20	37,7	28,5	1,22	8 500	8 500	0,47	-	7210 BEP
90		20	39	30,5	1,29	8 500	8 500	0,47	7210 BEC BY	7210 BEY
90		20	40	31	1,32	9 000	9 000	0,51	7210 BECBM	-
110		27	75	51	2,16	8 000	8 000	1,04	7310 BECBP	-
110		27	68,9	47,5	2	7 500	7 500	1,04	-	7310 BEP
110		27	74,1	51	2,2	7 500	7 500	1,13	7310 BEC BY	7310 BEY
110		27	75	51	2,16	8 000	8 000	1,16	7310 BECBM	-
55	100	21	48,8	38	1,63	7 500	7 500	0,62	7211 BECBP	7211 BEP
	100	21	48,8	38	1,63	7 500	7 500	0,62	7211 BEC BY	7211 BEY
	100	21	46,2	36	1,53	7 500	8 000	0,66	7211 BECBM	-
	120	29	85	60	2,55	7 000	7 000	1,34	7311 BECBP	-
	120	29	79,3	55	2,32	6 700	6 700	1,34	-	7311 BEP
	120	29	85,2	60	2,55	6 700	6 700	1,48	7311 BEC BY	7311 BEY
	120	29	85	60	2,55	7 000	7 000	1,49	7311 BECBM	-
	60	110	22	61	50	2,12	7 500	7 500	0,78	7212 BECBP
110		22	57,2	45,5	1,93	7 000	7 000	0,78	-	7212 BEP
110		22	57,2	45,5	1,93	7 000	7 000	0,83	7212 BEC BY	7212 BEY
110		22	61	50	2,12	7 500	7 500	0,85	7212 BECBM	-
130		31	104	76,5	3,2	6 700	6 700	1,71	7312 BECBP	-
130		31	95,6	69,5	3	6 000	6 000	1,71	-	7312 BEP
130		31	95,6	69,5	3	6 000	6 000	1,75	7312 BEC BY	7312 BEY
130		31	104	76,5	3,2	6 700	6 700	1,88	7312 BECBM	-
130		31	95,6	69,5	3	6 000	6 300	1,88	-	7312 BEM

* The designations of bearings belonging to the SKF Explorer performance class are printed blue. Information on available variants → pages 22 and 23

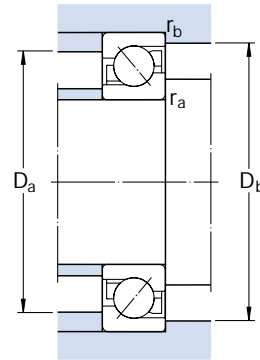
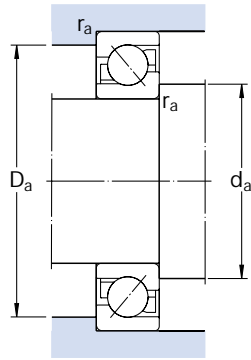

Conversion factors:

Length: 1 mm = 0,0394 in
 1 in = 25,4 mm
Force: 1 N = 0,225 lbf
 1 lbf = 4,4482 N
Mass: 1 kg = 2,205 lb
 1 lb = 0,454 kg

Dimensions

Abutment and fillet dimensions

d	d ₁ ~	d ₂ ~	D ₁ ~	r _{1,2} min	r _{3,4} min	a	d _a min	D _a max	D _b max	r _a max	r _b max
mm							mm				
40	56,3	48,1	65,6	1,1	0,6	34	47	73	75,8	1	0,6
	56,3	48,1	65,6	1,1	0,6	34	47	73	75,8	1	0,6
	56,3	48,1	65,6	1,1	0,6	34	47	73	75,8	1	0,6
	56,3	48,1	65,6	1,1	0,6	34	47	73	75,8	1	0,6
	56,3	48,1	65,6	1,1	0,6	34	47	73	75,8	1	0,6
	59,7	49,6	71,6	1,5	1	39	49	81	84,4	1,5	1
	59,7	49,6	71,6	1,5	1	39	49	81	84,4	1,5	1
	59,7	49,6	71,6	1,5	1	39	49	81	84,4	1,5	1
45	60,9	52,7	70,2	1,1	0,6	37	52	78	80,8	1	0,6
	60,9	52,7	70,2	1,1	0,6	37	52	78	80,8	1	0,6
	60,9	52,7	70,2	1,1	0,6	37	52	78	80,8	1	0,6
	60,9	52,7	70,2	1,1	0,6	37	52	78	80,8	1	0,6
	66,5	55,3	79,8	1,5	1	43	54	91	94,4	1,5	1
	66,5	55,3	79,8	1,5	1	43	54	91	94,4	1,5	1
	66,5	55,3	79,8	1,5	1	43	54	91	94,4	1,5	1
	66,5	55,3	79,8	1,5	1	43	54	91	94,4	1,5	1
50	65,8	57,7	75,2	1,1	0,6	39	57	83	85,8	1	0,6
	65,8	57,7	75,2	1,1	0,6	39	57	83	85,8	1	0,6
	65,8	57,7	75,2	1,1	0,6	39	57	83	85,8	1	0,6
	65,8	57,7	75,2	1,1	0,6	39	57	83	85,8	1	0,6
	73,8	61,1	88,8	2	1	47	61	99	104	2	1
	73,8	61,1	88,8	2	1	47	61	99	104	2	1
	73,8	61,1	88,8	2	1	47	61	99	104	2	1
	73,8	61,1	88,8	2	1	47	61	99	104	2	1
55	72,4	63,6	83,7	1,5	1	43	64	91	94	1,5	1
	72,4	63,6	83,7	1,5	1	43	64	91	94	1,5	1
	72,4	63,6	83,7	1,5	1	43	64	91	94	1,5	1
	80,3	66,7	96,6	2	1	51	66	109	114	2	1
	80,3	66,7	96,6	2	1	51	66	109	114	2	1
	80,3	66,7	96,6	2	1	51	66	109	114	2	1
	80,3	66,7	96,6	2	1	51	66	109	114	2	1
	80,3	66,7	96,6	2	1	51	66	109	114	2	1
60	79,6	69,3	91,55	1,5	1	47	69	101	104	1,5	1
	79,6	69,3	91,6	1,5	1	47	69	101	104	1,5	1
	79,6	69,3	91,6	1,5	1	47	69	101	104	1,5	1
	79,6	69,3	91,6	1,5	1	47	69	101	104	1,5	1
	87,3	72,6	104,8	2,1	1,1	55	72	118	123	2	1
	87,3	72,6	104,8	2,1	1,1	55	72	118	123	2	1
	87,3	72,6	104,8	2,1	1,1	55	72	118	123	2	1
	87,3	72,6	104,8	2,1	1,1	55	72	118	123	2	1
	87,3	72,6	104,8	2,1	1,1	55	72	118	123	2	1
	87,3	72,6	104,8	2,1	1,1	55	72	118	123	2	1

Single row angular contact ball bearings
d 65 – 90 mm

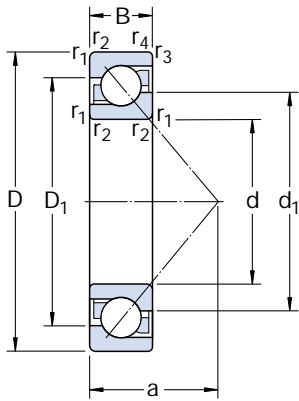

Principal dimensions			Basic load ratings		Fatigue load limit P _u	Speed ratings		Mass	Designations*	
d	D	B	dynamic C	static C ₀		Reference speed	Limiting speed		Universally matchable bearing	Basic design bearing
mm			kN		kN	r/min		kg	-	
65	120	23	66,3	54	2,28	6 300	6 300	1,00	7213 BECBP	7213 BEP
	120	23	66,3	54	2,28	6 300	6 300	1,00	7213 BECBy	7213 BEY
	120	23	66,3	54	2,28	6 300	6 700	1,10	7213 BECBM	-
	140	33	116	86,5	3,65	6 300	6 300	2,10	7313 BECBP	-
	140	33	108	80	3,35	5 600	5 600	2,15	7313 BECBy	7313 BEP
	140	33	116	86,5	3,65	6 300	6 300	2,31	7313 BECBM	-
70	125	24	75	64	2,7	6 300	6 300	1,10	7214 BECBP	-
	125	24	71,5	60	2,5	6 000	6 000	1,10	7214 BECBy	7214 BEP
	125	24	72	60	2,55	6 300	6 300	1,18	7214 BECBM	-
	150	35	127	98	3,9	5 600	5 600	2,55	7314 BECBP	-
	150	35	119	90	3,65	5 300	5 300	2,67	7314 BECBy	7314 BEP
	150	35	127	98	3,9	5 600	5 600	2,83	7314 BECBM	-
75	130	25	72,8	64	2,65	5 600	5 600	1,18	7215 BECBP	7215 BEP
	130	25	72,8	64	2,65	5 600	5 600	1,26	7215 BECBy	-
	130	25	70,2	60	2,5	5 600	6 000	1,29	7215 BECBM	-
	160	37	132	104	4,15	5 300	5 300	3,06	7315 BECBP	-
	160	37	125	98	3,8	5 000	5 000	3,06	-	7315 BEP
	160	37	133	106	4,15	5 000	5 000	3,20	7315 BECBy	-
	160	37	132	104	4,15	5 300	5 300	3,26	7315 BECBM	-
80	140	26	80,6	69,5	2,8	5 300	5 300	1,43	7216 BECBP	7216 BEP
	140	26	83,2	73,5	3	5 300	5 300	1,58	7216 BECBy	-
	140	26	85	75	3,05	5 600	5 600	1,59	7216 BECBM	-
	170	39	143	118	4,5	5 000	5 000	3,64	7316 BECBP	-
	170	39	135	110	4,15	4 500	4 500	3,64	-	7316 BEP
	170	39	143	118	4,5	4 500	4 500	3,70	7316 BECBy	7316 BEY
	170	39	143	118	4,5	5 000	5 000	4,03	7316 BECBM	-
	170	39	135	110	4,15	4 500	4 800	3,80	-	7316 BEM
85	150	28	95,6	83	3,25	5 000	5 000	1,83	7217 BECBP	7217 BEP
	150	28	95,6	83	3,25	5 000	5 000	1,83	7217 BECBy	-
	150	28	95,6	83	3,25	5 000	5 300	1,99	7217 BECBM	-
	180	41	156	132	4,9	4 800	4 800	4,26	7317 BECBP	-
	180	41	146	112	4,5	4 300	4 300	4,26	-	7317 BEP
	180	41	153	132	4,9	4 300	4 300	4,59	7317 BECBy	-
	180	41	156	132	4,9	4 800	4 800	4,74	7317 BECBM	-
	180	41	146	112	4,5	4 300	4 500	4,74	-	7317 BEM
	180	41	146	112	4,5	4 300	4 500	4,74	-	7317 BEM
90	160	30	108	96,5	3,65	4 500	4 500	2,12	7218 BECBP	7218 BEP
	160	30	108	96,5	3,65	4 500	4 500	2,34	7218 BECBy	-
	160	30	108	96,5	3,65	4 500	4 800	2,41	7218 BECBM	-
	190	43	166	146	5,3	4 500	4 500	4,98	7318 BECBP	-
	190	43	156	134	4,8	4 000	4 000	4,98	-	7318 BEP
	190	43	165	146	5,2	4 000	4 000	5,22	7318 BECBy	-
	190	43	166	146	5,3	4 500	4 500	5,53	7318 BECBM	-
	190	43	156	134	4,8	4 000	4 300	5,53	-	7318 BEM
	190	43	156	134	4,8	4 000	4 300	5,53	-	7318 BEM

* The designations of bearings belonging to the SKF Explorer performance class are printed blue. Information on available variants → pages 22 and 23

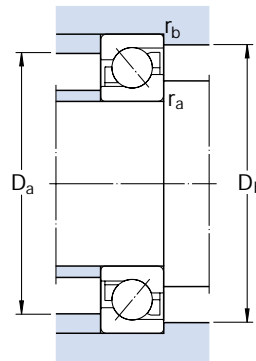
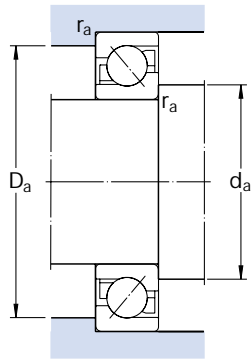

Conversion factors:

Length: 1 mm = 0,0394 in
 1 in = 25,4 mm
Force: 1 N = 0,225 lbf
 1 lbf = 4,4482 N
Mass: 1 kg = 2,205 lb
 1 lb = 0,454 kg

Dimensions

Abutment and fillet dimensions

d	d ₁ ~	d ₂ ~	D ₁ ~	r _{1,2} min	r _{3,4} min	a	d _a min	D _a max	D _b max	r _a max	r _b max
mm							mm				
65	86,4	75,5	100	1,5	1	50	74	111	114	1,5	1
	86,4	75,5	100	1,5	1	50	74	111	114	1,5	1
	86,4	75,5	100	1,5	1	50	74	111	114	1,5	1
	94,2	78,5	112,9	2,1	1,1	60	77	128	133	2	1
	94,2	78,5	112,9	2,1	1,1	60	77	128	133	2	1
	94,2	78,5	112,9	2,1	1,1	60	77	128	133	2	1
70	91,5	80,3	104,8	1,5	1	53	79	116	119	1,5	1
	91,5	80,3	104,8	1,5	1	53	79	116	119	1,5	1
	91,5	80,3	104,8	1,5	1	53	79	116	119	1,5	1
	101,1	84,4	121	2,1	1,1	64	82	138	143	2	1
	101,1	84,4	121	2,1	1,1	64	82	138	143	2	1
	101,1	84,4	121	2,1	1,1	64	82	138	143	2	1
75	96,3	85,3	110,1	1,5	1	56	84	121	124	1,5	1
	96,3	85,3	110,1	1,5	1	56	84	121	124	1,5	1
	96,3	85,3	110,1	1,5	1	56	84	121	124	1,5	1
	108,3	91,1	128,7	2,1	1,1	68	87	148	153	2	1
	108,3	91,1	128,7	2,1	1,1	68	87	148	153	2	1
	108,3	91,1	128,7	2,1	1,1	68	87	148	153	2	1
	108,3	91,1	128,7	2,1	1,1	68	87	148	153	2	1
80	103,6	91,4	117,9	2	1	59	91	129	134	2	1
	103,6	91,4	117,9	2	1	59	91	129	134	2	1
	103,6	91,4	117,9	2	1	59	91	129	134	2	1
	115,2	97,1	136,8	2,1	1,1	72	92	158	163	2	1
	115,2	97,1	136,8	2,1	1,1	72	92	158	163	2	1
	115,2	97,1	136,8	2,1	1,1	72	92	158	163	2	1
	115,2	97,1	136,8	2,1	1,1	72	92	158	163	2	1
	115,2	97,1	136,8	2,1	1,1	72	92	158	163	2	1
	115,2	97,1	136,8	2,1	1,1	72	92	158	163	2	1
85	110,1	97	126,7	2	1	63	96	139	144	2	1
	110,1	97	126,7	2	1	63	96	139	144	2	1
	110,1	97	126,7	2	1	63	96	139	144	2	1
	122,3	103	145	3	1,1	76	99	166	173	2,5	1
	122,3	103	145	3	1,1	76	99	166	173	2,5	1
	122,3	103	145	3	1,1	76	99	166	173	2,5	1
	122,3	103	145	3	1,1	76	99	166	173	2,5	1
	122,3	103	145	3	1,1	76	99	166	173	2,5	1
	122,3	103	145	3	1,1	76	99	166	173	2,5	1
90	117,1	103	134,8	2	1	67	101	149	154	2	1
	117,1	103	134,8	2	1	67	101	149	154	2	1
	117,1	103	134,8	2	1	67	101	149	154	2	1
	129,2	109	153,1	3	1,1	80	104	176	183	2,5	1
	129,2	109	153,1	3	1,1	80	104	176	183	2,5	1
	129,2	109	153,1	3	1,1	80	104	176	183	2,5	1
	129,2	109	153,1	3	1,1	80	104	176	183	2,5	1
	129,2	109	153,1	3	1,1	80	104	176	183	2,5	1
	129,2	109	153,1	3	1,1	80	104	176	183	2,5	1



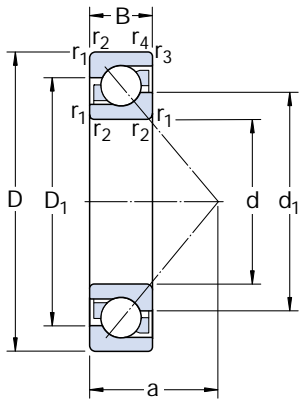

Principal dimensions			Basic load ratings		Fatigue load limit P _u	Speed ratings		Mass	Designations*	
d	D	B	dynamic C	static C ₀		Reference speed	Limiting speed		Universally matchable bearing	Basic design bearing
mm			kN		kN	r/min		kg	-	
95	170	32	124	108	4	4 300	4 300	2,68	7219 BECBP	7219 BEP
	170	32	124	108	4	4 300	4 300	2,82	7219 BECBY	-
	170	32	129	118	4,4	4 800	4 800	2,95	7219 BECBM	-
	200	45	180	163	5,7	4 300	4 300	5,77	7319 BECBP	-
	200	45	168	150	5,2	3 800	3 800	5,77	-	7319 BEP
	200	45	178	163	5,6	3 800	3 800	6,17	7319 BECBY	-
	200	45	180	163	5,7	4 300	4 300	6,41	7319 BECBM	-
	200	45	168	150	5,2	3 800	4 000	6,41	-	7319 BEM
100	180	34	135	122	4,4	4 000	4 000	3,29	7220 BECBP	7220 BEP
	180	34	135	122	4,4	4 000	4 000	3,38	7220 BECBY	7220 BEY
	180	34	135	122	4,4	4 000	4 300	3,61	7220 BECBM	-
	215	47	216	208	6,95	4 000	4 000	7,17	7320 BECBP	-
	215	47	203	190	6,4	3 600	3 600	7,17	-	7320 BEP
	215	47	203	190	6,4	3 600	3 600	7,15	7320 BECBY	7320 BEY
	215	47	216	208	6,95	4 000	4 000	8,00	7320 BECBM	-
	215	47	203	190	6,4	3 600	3 800	8,00	-	7320 BEM
105	190	36	148	137	4,8	3 800	3 800	3,82	7221 BECBP	7221 BEP
	190	36	148	137	4,8	3 800	4 000	4,18	7221 BECBM	-
	225	49	212	208	6,95	3 400	3 400	8,46	7321 BECBP	7321 BEP
	225	49	203	193	6,4	3 400	3 600	9,12	7321 BECBM	-
110	200	38	163	153	5,2	3 600	3 600	4,60	7222 BECBP	7222 BEP
	200	38	163	153	5,2	3 600	3 600	4,75	7222 BECBY	-
	200	38	153	143	4,9	3 600	3 800	4,95	7222 BECBM	7222 BEM
	240	50	225	224	7,2	3 200	3 200	9,69	7322 BECBP	7322 BEP
	240	50	225	224	7,2	3 200	3 200	9,69	7322 BECBY	7322 BEY
	240	50	225	224	7,2	3 200	3 400	10,7	7322 BECBM	7322 BEM
120	215	40	165	163	5,3	3 400	3 600	5,89	7224 BCBM	7224 BM
	260	55	238	250	7,65	3 000	3 200	13,8	7324 BCBM	-
130	230	40	186	193	6,1	3 200	3 400	6,76	7226 BCBM	7226 BM
	280	58	296	305	9	2 800	2 800	17,1	7326 BCBM	7326 BM
140	250	42	199	212	6,4	2 800	3 000	8,63	7228 BCBM	7228 BM
	300	62	302	345	9,8	2 600	2 600	21,3	7328 BCBM	-
150	270	45	216	240	6,95	2 600	2 800	10,8	7230 BCBM	-
	320	65	332	390	10,8	2 400	2 400	25,0	7330 BCBM	-
160	290	48	255	300	8,5	2 400	2 600	13,6	7232 BCBM	-
170	310	52	281	345	9,5	2 400	2 400	16,7	7234 BCBM	-
	360	72	390	490	12,7	2 000	2 200	34,6	7334 BCBM	-

* The designations of bearings belonging to the SKF Explorer performance class are printed blue. Information on available variants → pages 22 and 23

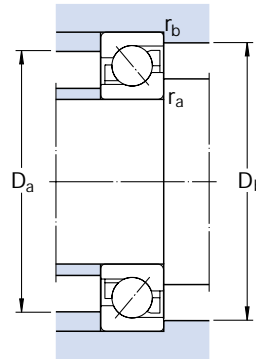
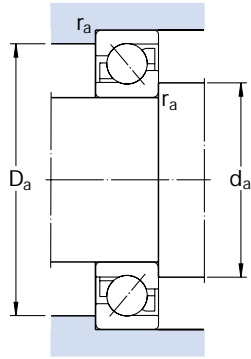

Conversion factors:

Length: 1 mm = 0,0394 in
 1 in = 25,4 mm
Force: 1 N = 0,225 lbf
 1 lbf = 4,4482 N
Mass: 1 kg = 2,205 lb
 1 lb = 0,454 kg

Dimensions

Abutment and fillet dimensions

d	d ₁ ~	d ₂ ~	D ₁ ~	r _{1,2} min	r _{3,4} min	a	d _a min	D _a max	D _b max	r _a max	r _b max
mm							mm				
95	124,3	109,1	142,5	2,1	1,1	72	107	158	163	2	1
	124,3	109,1	142,5	2,1	1,1	72	107	158	163	2	1
	124,3	109,1	142,5	2,1	1,1	72	107	158	163	2	1
	136,2	114,9	161,3	3	1,1	84	109	186	193	2,5	1
	136,2	114,9	161,3	3	1,1	84	109	186	193	2,5	1
	136,2	114,9	161,3	3	1,1	84	109	186	193	2,5	1
	136,2	114,9	161,3	3	1,1	84	109	186	193	2,5	1
100	131	115,2	150,9	2,1	1,1	76	112	168	173	2	1
	131	115,2	150,9	2,1	1,1	76	112	168	173	2	1
	131	115,2	150,9	2,1	1,1	76	112	168	173	2	1
	144,5	120,5	173,4	3	1,1	90	114	201	-	2,5	-
	144,5	120,5	173,4	3	1,1	90	114	201	208	2,5	1
	144,5	120,5	173,4	3	1,1	90	114	201	208	2,5	1
	144,5	120,5	173,4	3	1,1	90	114	201	-	2,5	-
105	138	121,2	159,1	2,1	1,1	80	117	178	183	2	1
	138	121,2	159,1	2,1	1,1	80	117	178	183	2	1
	151,7	127,9	181,4	3	1,1	94	119	211	218	2,5	1
	151,7	127,9	181,4	3	1,1	94	119	211	218	2,5	1
110	144,9	127,1	167,4	2,1	1,1	84	122	188	193	2	1
	144,9	127,1	167,4	2,1	1,1	84	122	188	193	2	1
	144,9	127,1	167,4	2,1	1,1	84	122	188	193	2	1
	160,8	135	193,5	3	1,1	99	124	226	233	2,5	1
	160,8	135	193,5	3	1,1	99	124	226	233	2,5	1
	160,8	135	193,5	3	1,1	99	124	226	233	2,5	1
120	157	138,6	179,4	2,1	1,1	90	132	203	208	2	1
	178,4	153,9	211	3	1,5	107	134	246	253	2,5	1
130	169	149,6	192,6	3	1,1	96	144	216	222	2,5	1
	189,9	161,4	227,5	4	1,5	115	147	263	271	3	1,5
140	183,3	163,6	209,5	3	1,1	103	154	236	243	2,5	1
	203	172,2	243	4	1,5	123	157	283	291	3	1,5
150	197,2	175,6	226	3	1,1	111	164	256	263	2,5	1
	216,1	283,9	258,7	4	1,5	131	167	303	311	3	1,5
160	211	187,6	242,3	3	1,1	118	174	276	283	2,5	1
170	227,4	202	261	4	1,5	127	187	293	301	3	1,5
	243,8	207,9	292	4	2	147	187	343	351	3	1,5

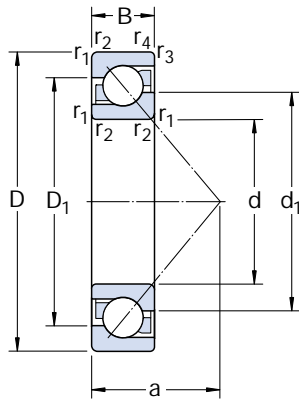

Principal dimensions		Basic load ratings		Fatigue load limit P_u	Speed ratings		Mass	Designation* Universally matchable bearing	
d	D	dynamic	static		Reference speed	Limiting speed			
	B	C	C_0						
mm		kN		kN	r/min		kg	-	
180	320	52	291	375	10	2 200	2 400	17,6	7236 BCBM
	380	75	410	540	13,7	2 000	2 000	40,0	7336 BCBM
190	340	55	307	405	10,4	2 000	2 200	21,9	7238 BCBM
	400	78	442	600	14,6	1 900	1 900	48,3	7338 BCBM
200	360	58	325	430	11	1 800	2 000	25,0	7240 BCBM
	420	80	462	655	15,6	1 800	1 800	52,8	7340 BCBM
220	400	65	319	465	11,2	1 800	1 800	35,2	7244 BCBM
240	440	72	364	540	12,5	1 600	1 700	49,0	7248 BCBM

* Information on available variants → pages 22 and 23

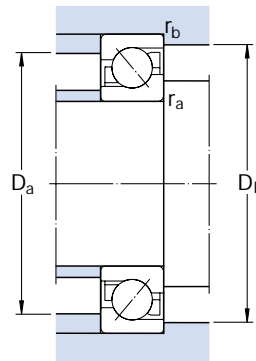
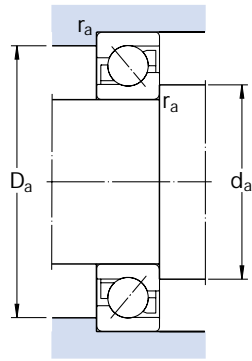

Conversion factors:

Length: 1 mm = 0,0394 in
 1 in = 25,4 mm
Force: 1 N = 0,225 lbf
 1 lbf = 4,4482 N
Mass: 1 kg = 2,205 lb
 1 lb = 0,454 kg

Dimensions

Abutment and fillet dimensions

d	d_1 ~	d_2 ~	D_1 ~	$r_{1,2}$ min	$r_{3,4}$ min	a	d_a min	D_a max	D_b max	r_a max	r_b max
mm							mm				
180	234,9 257,7	209,6 219,8	268,8 308	4 4	1,5 2	131 156	197 197	303 363	311 369	3 3	1,5 2
190	250,4 271,6	224,1 231,8	285,4 324,3	4 5	1,5 2	139 164	207 210	323 380	331 389	3 4	1,5 2
200	263,3 287	235,1 247	300,8 339,5	4 5	1,5 2	146 170	217 220	343 400	351 409	3 4	1,5 2
220	291,1	259,1	333,4	4	1,5	164	237	383	391	3	1,5
240	322	292	361	4	1,5	180	257	423	431	3	1,5

Double row angular contact ball bearings

Fig 1

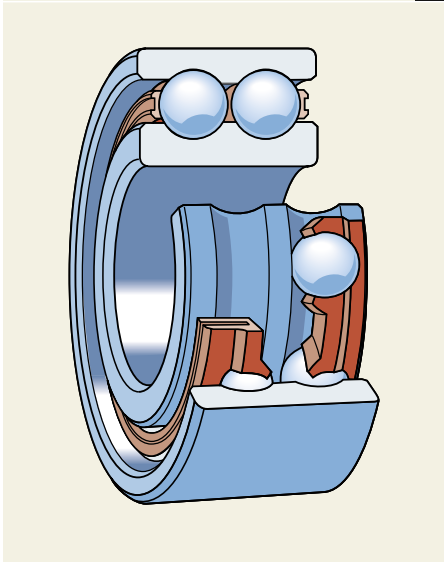

Double row angular contact ball bearing

General bearing data

Designs

SKF double row angular contact ball bearings correspond in design to two single row angular contact ball bearings but take up less axial space (→ fig 1).

The SKF standard range of double row angular contact ball bearings includes

- bearings of basic design, suffix designation A (→ figs 2a and 2b),
- bearings with shields, suffix designation A-2Z (→ figs 2c and 2d),
- bearings with seals, suffix designation A-2RS1 (→ fig 2e),
- separable bearings with a two-piece inner ring, suffix designation D (→ fig 2f),
- non-separable bearings with a two-piece inner ring and snap ring, suffix designation DNRCBM (→ fig 2g).

The bearing range covers sizes from 10 to 110 mm bore diameter.

For information about other double row angular contact ball bearings, please refer to the "SKF Interactive Engineering Catalogue" on CD-ROM or online at www.skf.com.

Basic design

Double row angular contact ball bearings in the 32 A and 33 A series have a 30° contact angle and are non-separable. These bearings do not contain filling slots and therefore can accommodate axial loads acting in both directions. Many of these bearings are manufactured as SKF Explorer bearings.

For manufacturing reasons, bearings of the basic design may have seal recesses on inner and outer rings, even if they are supplied without seals or shields (→ fig 2b).

Sealed bearings

SKF bearings in the 32 A and 33 A series are available with

- shields (non-contact seals) or
- seals (contact seals)

at both sides. As standard, these bearings are filled with an NLGI Class 3 lithium thickener grease, which has good corrosion inhibiting properties and can be used at temperatures between -30 and +120 °C (-20 and + 250 °F). Bearings with this lithium thickener grease carry the suffix MT33.

If sealed double row bearings with a high-temperature grease are needed, bearings in the 52 A or 53 A series should be ordered. These bearings are filled with an NGLI Class 2 mineral-oil based grease and polyurea thickener. This grease is resistant to ageing and has good corrosion inhibiting properties. Its operating temperature range is -30 to +175 °C (-20 to +345 °F). The temperature is nevertheless limited to 150 °C (300 °F) by the bearing rings or to 120 °C (250 °F) if seals or polyamide cages are used.

Sealed bearings are lubricated for life and are maintenance-free and should therefore not be washed or heated above 80 °C (175 °F) prior to mounting.

Bearings in the 52 A and 53 A series

Basic design bearings in the 32 A and 33 A series shown in this brochure as well as the corresponding sealed bearings to 2Z and 2RS1 design are identical to the corresponding bearings in the 52 A and 53 A series for the North American market. They have the same performance characteristics and dimensional features (except for the width of size 5200). However, the sealed bearings are filled with a different grease.

Fig 2

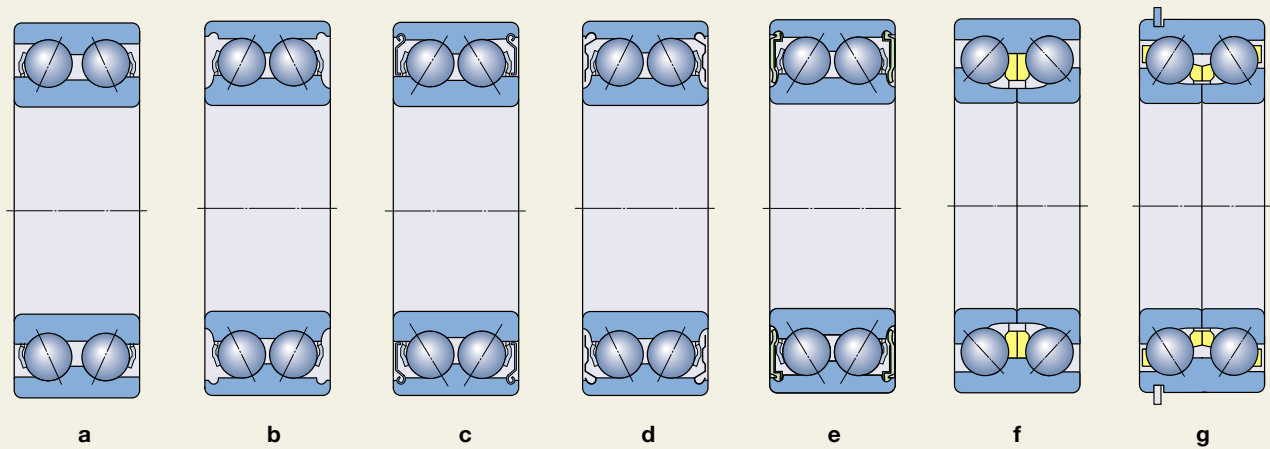

Design alternatives of double row angular contact ball bearings

Bearings with shields

Bearings with shields made of sheet steel are supplied in two different designs depending on the bearing variant:

- Standard design bearings have shields which form a long sealing gap with the land of the inner ring shoulder (→ fig 3a).
- SKF Explorer bearings are equipped with shields which overlap the recesses in the inner ring shoulder and form a highly efficient labyrinth seal (→ fig 3b).

Bearings with seals

Bearings with seals, designation suffix 2RS1, have an acrylonitrile butadiene rubber, sheet steel reinforced seal at both sides (→ fig 3c). The seal material is resistant to ageing and wear. The temperature limits for the seals are -40 to +100 °C (-40 to +210 °F) and up to +120 °C (+250 °F) for brief periods. The periphery of the seal engages in a recess in the outer ring without deforming the ring and provides good sealing at this position. The rubber lip seals against a recess in the inner ring shoulder, exerting a slight pressure on the ring.

Bearings in the 33 D series

SKF double row angular contact ball bearings in the 33 D series (→ fig 2f) with a two-piece inner ring incorporate a large number of large balls and have high load carrying capacity as a consequence. The bearings have a 45° contact angle and can support heavy axial loads in both directions. The bearings are separable.

Bearings in the 33 DNRCBM series

Bearings in the 33 DNRCBM series (→ fig 2g) have been designed specifically to operate under the conditions

Bearings with shields and seals

Fig 3

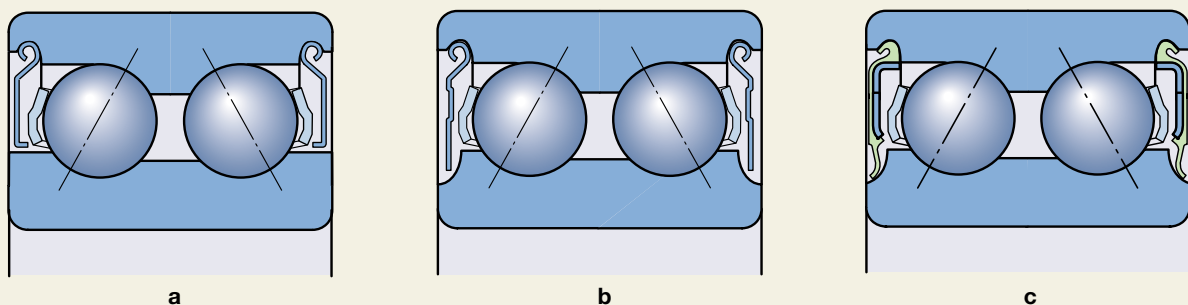

pertaining in centrifugal pumps, but can also be used in other applications. Their principal characteristics are

- a 40° contact angle,
- a split inner ring,
- machined brass cages, ball centred,
- higher running accuracy,
- a snap ring groove and a snap ring in the outer ring, enabling simple and space-saving axial location in the housing.

Dimensions

With the exception of the width of a 3200 A bearing, the boundary dimensions of the double row angular contact ball bearings listed in the product tables conform to ISO 15:1998.

Tolerances

SKF Explorer double row bearings as well as the bearings in 33 DNRCBM series are manufactured to P6 dimensional and running accuracy.

Other SKF double row angular contact ball bearings are manufactured to Normal tolerances.

The values for the tolerances correspond to ISO 492:2002.

Clearance

SKF double row angular contact ball bearings in the 32 A and 33 A series are available with Normal as well as C3 axial internal clearance as standard (→ tables 2 and 3 on pages 38 and 39).

The bearings in the 33 D and 33 DNRCBM series are only manufactured to the special axial internal clearance listed in table 1.

The values for axial internal clearances given in table 1 are valid for bearings before mounting and under zero measuring load.

Misalignment

Double row angular contact ball bearings are limited in their ability to compensate for shaft misalignment and axial deflections. Both conditions will increase noise, and decrease bearing service life.

Cages

SKF double row angular contact ball bearings are fitted with one cage per ball row. The type of cage typically depends on bearing design and size. In some cases two different cages are available so that bearings with cages appropriate to the operating conditions can be chosen:

Double row bearings

- Standard design bearings in the 32 A and 33 A series:
 - snap type cage of glass fibre reinforced polyamide 6,6, ball centred, designation suffix TN9 (→ fig 4) or
 - pressed steel, snap type cage, ball centred, no designation suffix (→ fig 5).
- SKF Explorer bearings in the 32 A and 33 A series:
 - pressed steel, crown type cage, ball centred, no designation suffix (→ fig 6) or
 - snap type cage of glass fibre reinforced polyamide 6,6, ball centred, designation suffix TN9 (→ fig 4).
- Bearings in the 33 D series:
 - snap type cage of glass fibre reinforced polyamide 6,6, ball centred, designation suffix TN9 (→ fig 4) or
 - pressed steel snap type cage, ball centred, designation suffix J1 (→ fig 5) or
 - machined brass cage, outer ring centred, designation suffix MA (→ fig 7).
- Bearings in the 33 DNRCBM series:
 - machined brass cage, ball centred, designation suffix M (→ fig 8).

Axial internal clearance of double row angular contact ball bearings (before mounting and under zero measuring load)

Table 1

Bore diameter d over incl.		Axial internal clearance for bearings in the series							
		32 A and 33 A				33 D		33 DNRCBM	
		C2		Normal		C3			
		min	max	min	max	min	max	min	max
mm		µm							
–	10	1	11	5	21	12	28	–	–
10	18	1	12	6	23	13	31	–	–
18	24	2	14	7	25	16	34	–	–
24	30	2	15	8	27	18	37	–	–
30	40	2	16	9	29	21	40	33	54
40	50	2	18	11	33	23	44	36	58
50	65	3	22	13	36	26	48	40	63
65	80	3	24	15	40	30	54	46	71
80	100	3	26	18	46	35	63	55	83
100	110	4	30	22	53	42	73	65	96

Note

Double row angular contact ball bearings with polyamide 6,6 cages can be used at temperatures up to +120 °C (250 °F). With the exception of a few oils and greases with a synthetic base oil, and lubricants containing a high proportion of EP additives when used at high temperatures, the lubricants generally used for rolling bearings do not have a detrimental effect on cage properties.

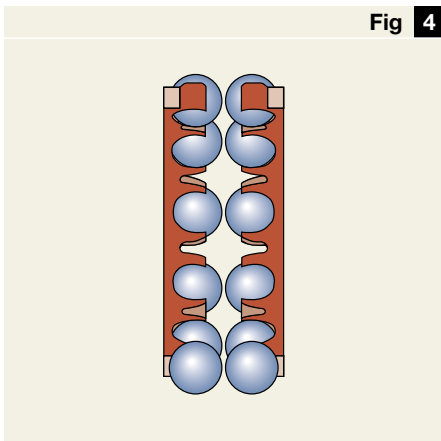

Polyamide cage

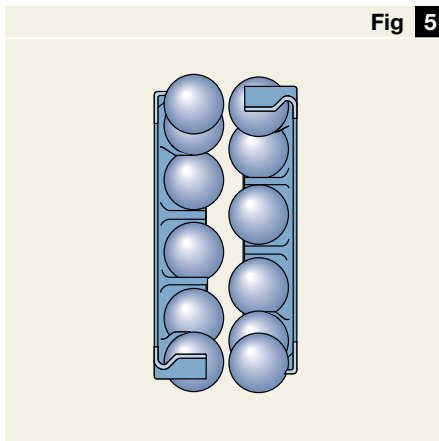

Snap cage of sheet steel

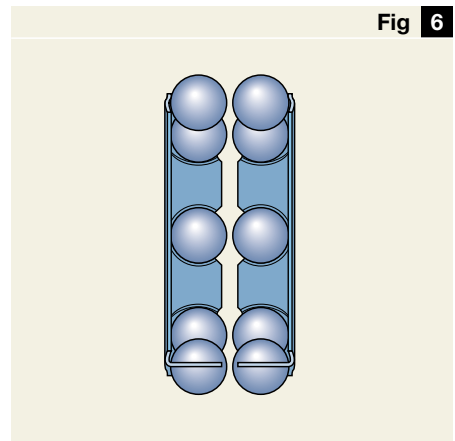

Crown cage of sheet steel

Tables 2 and 3 on pages 38 and 39 show which cage designs are available for which bearing. Information on "Cage selection criteria" can be found on page 15. For additional information about cages, contact your local SKF representative.

Designation suffixes

The designation suffixes which occur most frequently with double row angular contact ball bearings, are listed and explained below.

- A** Optimized internal design, no filling slots
- CB** Controlled axial internal clearance
- C2** Axial internal clearance smaller than Normal
- C3** Axial internal clearance greater than Normal
- D** Two-piece inner ring
- J1** Sheet steel cage, ball centred
- M** Machined brass cage, ball centred
- MA** Machined brass cage, outer ring centred
- MT33** Lithium thickener grease for operating temperatures in the range of -30 to +120 °C (-20 to +250 °F)
- NR** Snap ring groove in the outer ring with snap ring
- P5** Dimensional and running accuracy to ISO tolerance class 5
- P6** Dimensional and running accuracy to ISO tolerance class 6

- P62** P6 running accuracy and C2 axial internal clearance
- P63** P6 running accuracy and C3 axial internal clearance
- TN9** Snap type cage of glass fibre reinforced polyamide 6,6, ball centred
- 2RS1** Sheet steel reinforced acrylonitrile butadiene rubber seals on both sides of the bearing
- 2Z** Pressed steel shields on both sides of the bearing

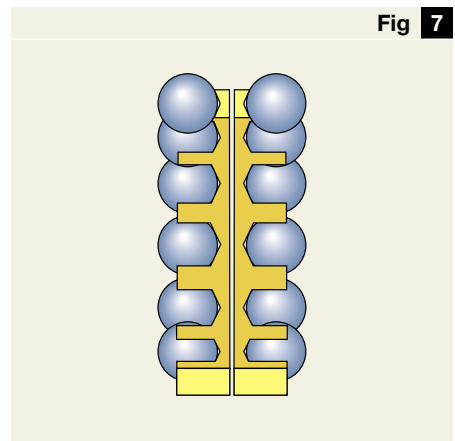

Machined brass cage, outer ring centred

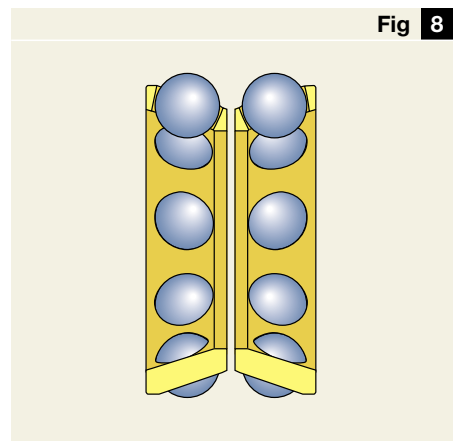

Machined brass cage, ball centred

Assortment

SKF double row angular contact ball bearings in the 32 and 33 series are available in a large number of variants. The standard assortment for bearings in the

- 32 A series is listed in **table 2** and
- 33 A and 33 D series is listed in **table 3**.

The dimensions and performance data of these bearings can be found in the product tables starting on **page 40**.

Additional variants with other internal clearance values or different cage variations are available. For details, contact your local SKF representative.

Bearing designations

Tables 2 and **3** also contain the bearing designations of the bearings available in the standard assortment. The table headings show bearing designations without the size code; a grey coloured square indicates the position for the size.

Example of an order designation

A double row angular contact ball bearing in the 33 A series

- with a 40 mm bore diameter (bearing size 08),
- with shields on both sides (-2Z),
- with snap type cage of glass fibre reinforced polyamide 6,6 (TN9),
- with axial internal clearance greater than Normal (C3),
- with lithium thickener grease (MT33)

has 3308 A-2ZTN9/C3MT33 as order designation. The meaning of relevant designation suffixes is explained on **page 37**.

Table **2**

Bore diameter mm	Bearings of open design				Bearings with shields				Bearings with seals		Bearing size
	A	A/C3	ATN9	ATN9/C3	A-2Z/MT33	A-2Z/C3MT33	A-2ZTN9/MT33	A-2ZTN9/C3MT33	A-2RS1/MT33	A-2RS1TN9/MT33	
10											00
12											01
15											02
17											03
20	■	■	■	■	■	■	■	■	■	■	04
25	■	■	■	■	■	■	■	■	■	■	05
30	■	■	■	■	■	■	■	■	■	■	06
35	■	■	■	■	■	■	■	■	■	■	07
40	■	■	■	■	■	■	■	■	■	■	08
45	■	■	■	■	■	■	■	■	■	■	09
50	■	■	■	■	■	■	■	■	■	■	10
55	■	■	■	■	■	■	■	■	■	■	11
60	■	■	■	■	■	■	■	■	■	■	12
65	■	■	■	■	■	■	■	■	■	■	13
70	■	■	■	■	■	■	■	■	■	■	14
75	■	■	■	■	■	■	■	■	■	■	15
80	■	■	■	■	■	■	■	■	■	■	16
85	■	■	■	■	■	■	■	■	■	■	17
90	■	■	■	■	■	■	■	■	■	■	18
95	■	■	■	■	■	■	■	■	■	■	19
100	■	■	■	■	■	■	■	■	■	■	20
110	■	■	■	■	■	■	■	■	■	■	22

■ SKF Explorer bearing
 ■ Other SKF standard bearing



Bearings in the 52 A series

This table is also valid for bearings in the 52 A series, which are identical to the corresponding bearings in the 32 A series. However, sealed bearings in the 52 A series are filled with a high-temperature grease. They do not carry any designation suffix for the grease.

SKF standard assortment of double row angular contact ball bearings in the 32 A series

Table 3

Bore diameter mm	Bearings of open design				Bearings with shields				Bearings with seals		Bearings with a two-piece inner ring				Bearing size
	A	A/C3	ATN9	ATN9/C3	A-ZZ/MT33	A-ZZ/C3MT3	A-ZZTN9/MT33	A-ZZTN9/C3MT33	A-2RS1/MT33	A-2RS1TN9/MT33	DJ1	DTN9	DMA	DNRCBM	
10															00
12															01
15															02
17															03
20															04
25															05
30															06
35															07
40															08
45															09
50															10
55															11
60															12
65															13
70															14
75															15
80															16
85															17
90															18
95															19
100															20
110															22

 SKF Explorer bearing
 Other SKF standard bearing

Bearings in the 53 A series

This matrix is also valid for bearings in the 53 A series, which are identical to the corresponding bearings in the 33 A series. However, sealed bearings in the 53 A series are filled with a high-temperature grease. They do not carry any designation suffix for the grease.

SKF standard assortment of double row angular contact ball bearings in the 33 A and 33 D series

Double row angular contact ball bearings
d 10 – 60 mm

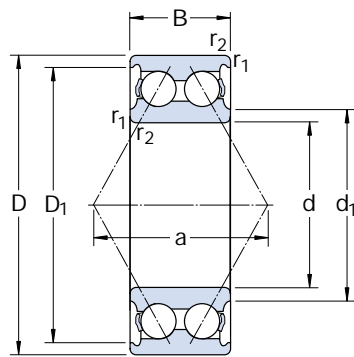

A design

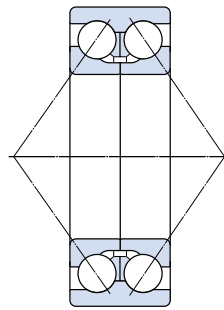

33 D

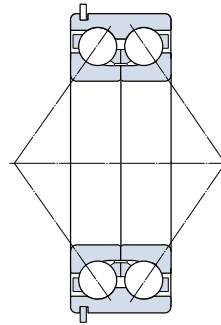

33 DNRCBM

Principal dimensions			Basic load ratings		Fatigue load limit P _u	Speed ratings		Mass	Designations*	
d	D	B	dynamic	static		Reference speed	Limiting speed		Bearing with metallic cage	polyamide cage
mm			kN		kN	r/min		kg	–	
10	30	14	7,61	4,3	0,183	22 000	24 000	0,051	–	3200 ATN9
12	32	15,9	10,1	5,6	0,24	20 000	22 000	0,058	–	3201 ATN9
15	35	15,9	11,2	6,8	0,285	17 000	18 000	0,066	–	3202 ATN9
	42	19	15,1	9,3	0,4	15 000	16 000	0,13	–	3302 ATN9
17	40	17,5	14,3	8,8	0,365	15 000	16 000	0,096	–	3203 ATN9
	47	22,2	21,6	12,7	0,54	14 000	14 000	0,18	–	3303 ATN9
20	47	20,6	20	12	0,51	14 000	14 000	0,16	3204 A	3204 ATN9
	52	22,2	23,6	14,6	0,62	13 000	13 000	0,22	3304 A	3304 ATN9
25	52	20,6	21,6	14,3	0,6	12 000	12 000	0,18	3205 A	3205 ATN9
	62	25,4	32	20,4	0,865	11 000	11 000	0,35	3305 A	3305 ATN9
30	62	23,8	30	20,4	0,865	10 000	10 000	0,29	3206 A	3206 ATN9
	72	30,2	41,5	27,5	1,16	9 000	9 000	0,53	3306 A	3306 ATN9
35	72	27	40	28	1,18	9 000	9 000	0,44	3207 A	3207 ATN9
	80	34,9	52	35,5	1,5	8 500	8 500	0,71	3307 A	3307 ATN9
	80	34,9	52,7	41,5	1,76	7 500	8 000	0,79	3307 DJ1	–
40	80	30,2	47,5	34	1,43	8 000	8 000	0,58	3208 A	3208 ATN9
	90	36,5	64	44	1,86	7 500	7 500	1,05	3308 A	3308 ATN9
	90	36,5	49,4	41,5	1,76	6 700	7 000	1,20	3308 DNRCBM	–
	90	36,5	68,9	64	2,45	6 700	7 000	1,05	3308 DMA	3308 DTN9
45	85	30,2	51	39	1,63	7 500	7 500	0,63	3209 A	3209 ATN9
	100	39,7	75	53	2,24	6 700	6 700	1,40	3309 A	3309 ATN9
	100	39,7	61,8	52	2,2	6 000	6 300	1,50	3309 DNRCBM	–
	100	39,7	79,3	69,5	3	6 000	6 300	1,60	3309 DMA	–
50	90	30,2	51	39	1,66	7 000	7 000	0,66	3210 A	3210 ATN9
	110	44,4	90	64	2,75	6 000	6 000	1,95	3310 A	3310 ATN9
	110	44,4	81,9	69,5	3	5 300	5 600	1,95	3310 DNRCBM	–
	110	44,4	93,6	85	3,6	5 300	5 600	2,15	3310 DMA	–
55	100	33,3	60	47,5	2	6 300	6 300	1,05	3211 A	3211 ATN9
	120	49,2	112	81,5	3,45	5 300	5 300	2,55	3311 A	–
	120	49,2	95,6	83	3,55	4 800	5 000	2,55	3311 DNRCBM	–
	120	49,2	111	100	4,3	4 800	5 000	2,80	3311 DMA	–
60	110	36,5	73,5	58,5	2,5	5 600	5 600	1,40	3212 A	3212 ATN9
	130	54	127	95	4,05	5 000	5 000	3,25	3312 A	–

* The designations of bearings belonging to the SKF Explorer performance class are printed blue. Information on available variants → pages 38 and 39
The bearings in the 32 A and 33 A series are identical with those in the 52 A and 53 A series for the North American market

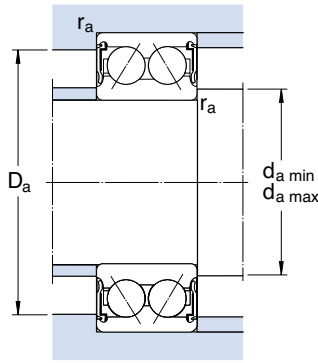
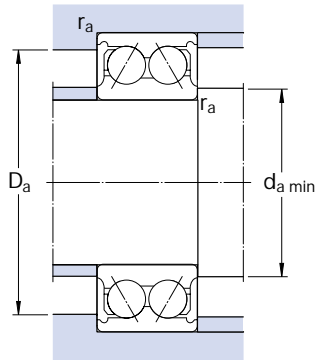

Conversion factors:

Length: 1 mm = 0,0394 in
 1 in = 25,4 mm
Force: 1 N = 0,225 lbf
 1 lbf = 4,4482 N
Mass: 1 kg = 2,205 lb
 1 lb = 0,454 kg

Dimensions

Abutment and fillet dimensions

d	d ₁ ≈	D ₁ ≈	r _{1,2} min	a	d _a min	D _a max	r _a max
				mm			
10	17,7	23,6	0,6	16	14,4	25,6	0,6
12	19,1	26,5	0,6	19	16,4	27,6	0,6
15	22,1 25,4	29,5 34,3	0,6 1	21 24	19,4 20,6	30,6 36,4	0,6 1
17	25,1 27,3	33,6 38,8	0,6 1	23 28	21,4 22,6	35,6 41,4	0,6 1
20	27,7 29,9	40,9 44,0	1 1,1	28 30	25,6 27	41,4 45	1 1
25	32,7 35,7	45,9 53,4	1 1,1	30 36	30,6 32	46,4 55	1 1
30	38,7 39,8	55,2 64,1	1 1,1	36 42	35,6 37	56,4 65	1 1
35	45,4 44,6 52,8	63,9 70,5 69,0	1,1 1,5 1,5	42 47 76	42 44 44	65 71 71	1 1,5 1,5
40	47,8 50,8 60,1 59,4	72,1 80,5 79,5 80,3	1,1 1,5 1,5 1,5	46 53 71 84	47 49 49 49	73 81 81 81	1 1,5 1,5 1,5
45	52,8 55,6 68 70	77,1 90 87,1 86,4	1,1 1,5 1,5 1,5	49 58 79 93	52 54 54 54	78 91 91 91	1 1,5 1,5 1,5
50	57,8 62 74,6 76,5	82,1 99,5 87 94,2	1,1 2 2 2	52 65 88 102	57 61 61 61	83 99 99 99	1 2 2 2
55	63,2 68,4 81,6 81,3	92,3 109,4 106,5 104,4	1,5 2 2 2	57 72 97 114	64 66 66 66	91 109 109 109	1,5 2 2 2
60	74,4 84,2	96,2 110	1,5 2,1	63 78	69 72	101 118	1,5 2

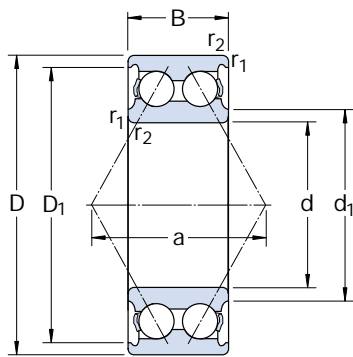

A design

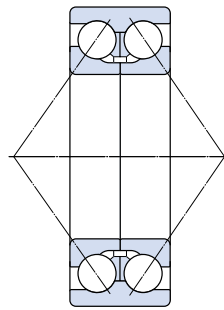

33 D

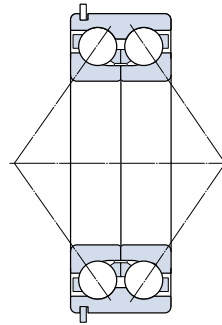

33 DNRCBM

Principal dimensions			Basic load ratings		Fatigue load limit P _u	Speed ratings		Mass	Designation* Bearing with metallic cage
d	D	B	dynamic	static		Reference speed	Limiting speed		
mm			kN		kN	r/min		kg	–
65	120	38,1	80,6	73,5	3,1	4 500	4 800	1,75	3213 A
	140	58,7	146	110	4,55	4 500	4 500	4,10	3313 A
	140	58,7	138	122	5,1	4 300	4 500	4,00	3313 DNRCBM
70	125	39,7	88,4	80	3,4	4 300	4 500	1,90	3214 A
	150	63,5	153	125	5	4 000	4 000	5,05	3314 A
75	130	41,3	95,6	88	3,75	4 300	4 500	2,10	3215 A
	160	68,3	176	140	5,5	4 000	4 000	5,55	3315 A
80	140	44,4	106	95	3,9	4 000	4 300	2,65	3216 A
	170	68,3	182	156	6	3 400	3 600	6,80	3316 A
	170	68,3	190	196	7,35	3 400	3 600	7,55	3316 DMA
85	150	49,2	124	110	4,4	3 600	3 800	3,40	3217 A
	180	73	195	176	6,55	3 200	3 400	8,30	3317 A
90	160	52,4	130	120	4,55	3 400	3 600	4,15	3218 A
	190	73	195	180	6,4	3 000	3 200	9,25	3318 A
	190	73	225	250	8,8	3 000	3 200	10,0	3318 DMA
95	170	55,6	159	146	5,4	3 200	3 400	5,00	3219 A
	200	77,8	225	216	7,5	2 800	3 000	11,0	3319 A
	200	77,8	242	275	9,5	2 800	3 000	12,0	3319 DMA
100	180	60,3	178	166	6	3 000	3 200	6,10	3220 A
	215	82,6	255	255	8,65	2 600	2 800	13,5	3320 A
	215	82,6	260	305	10,4	2 600	2 800	15,0	3320 DMA
110	200	69,8	212	212	7,2	2 800	2 800	8,80	3222 A
	240	92,1	291	305	9,8	2 400	2 600	19,0	3322 A
	240	92,1	307	375	12	2 400	2 600	21,0	3322 DMA

* The designations of bearings belonging to the SKF Explorer performance class are printed blue. Information on available variants → pages 38 and 39
The bearings in the 32 A and 33 A series are identical with those in the 52 A and 53 A series for the North American market

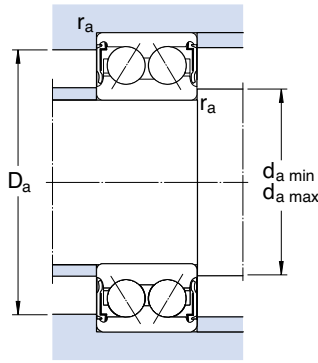
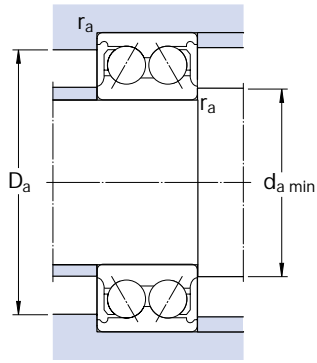

Conversion factors:

- Length:** 1 mm = 0,0394 in
 1 in = 25,4 mm
- Force:** 1 N = 0,225 lbf
 1 lbf = 4,4482 N
- Mass:** 1 kg = 2,205 lb
 1 lb = 0,454 kg

Dimensions

Abutment and fillet dimensions

d	d ₁ ≈	D ₁ ≈	r _{1,2} min	a	d _a min	D _a max	r _a max
mm					mm		
65	85	103	1,5	71	74	111	1,5
	89,8	116	2,1	84	77	128	2
	95,1	126	2,1	114	77	128	2
70	88,5	107	1,5	74	79	116	1,5
	84,2	139	2,1	89	82	138	2
75	91,9	112	1,5	77	84	121	1,5
	88,8	147	2,1	97	87	148	2
80	97,7	120	2	82	91	129	2
	108	143	2,1	101	92	158	2
	114	145	2,1	158	92	158	2
85	104	128	2	88	96	139	2
	116	153	3	107	99	166	2,5
90	111	139	2	94	101	149	2
	123	160	3	112	104	176	2,5
	130	167	3	178	104	176	2,5
95	119	147	2,1	101	107	158	2
	127	168	3	118	109	186	2,5
	138	177	3	189	109	186	2,5
100	125	155	2,1	107	112	168	2
	136	180	3	127	114	201	2,5
	144	186	3	199	114	201	2,5
110	139	173	2,1	119	122	188	2
	153	200	3	142	124	226	2,5
	157	204	3	217	124	226	2,5

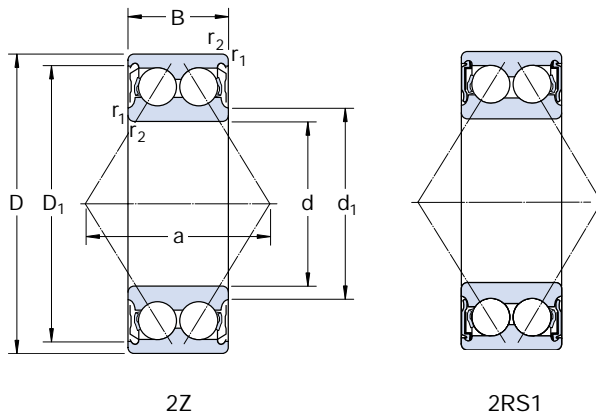

Principal dimensions			Basic load ratings		Fatigue load limit P _u	Limiting speeds		Mass	Designations*	
d	D	B	dynamic C	static C ₀		Bearing with shields	seals		Bearing with shields	seals
mm			kN		kN	r/min	kg	–		
10	30	14	7,61	4,3	0,183	24 000	17 000	0,051	3200 A-2Z	3200 A-2RS1
12	32	15,9	10,1	5,6	0,24	22 000	15 000	0,058	3201 A-2Z	3201 A-2RS1
15	35	15,9	11,2	6,8	0,285	18 000	14 000	0,066	3202 A-2Z	3202 A-2RS1
	42	19	15,1	9,3	0,4	16 000	12 000	0,13	3302 A-2Z	3302 A-2RS1
17	40	17,5	14,3	8,8	0,365	16 000	12 000	0,10	3203 A-2Z	3203 A-2RS1
	47	22,2	21,6	12,7	0,54	14 000	11 000	0,18	3303 A-2Z	3303 A-2RS1
20	47	20,6	20	12	0,51	14 000	10 000	0,16	3204 A-2Z	3204 A-2RS1
	52	22,2	23,6	14,6	0,62	13 000	9 000	0,22	3304 A-2Z	3304 A-2RS1
25	52	20,6	21,6	14,3	0,6	12 000	8 500	0,18	3205 A-2Z	3205 A-2RS1
	62	25,4	32	20,4	0,865	11 000	7 500	0,35	3305 A-2Z	3305 A-2RS1
30	62	23,8	30	20,4	0,865	10 000	7 500	0,29	3206 A-2Z	3206 A-2RS1
	72	30,2	41,5	27,5	1,16	9 000	6 300	0,52	3306 A-2Z	3306 A-2RS1
35	72	27	40	28	1,18	9 000	6 300	0,44	3207 A-2Z	3207 A-2RS1
	80	34,9	52	35,5	1,5	8 500	6 000	0,73	3307 A-2Z	3307 A-2RS1
40	80	30,2	47,5	34	1,43	8 000	5 600	0,57	3208 A-2Z	3208 A-2RS1
	90	36,5	64	44	1,86	7 500	5 000	0,93	3308 A-2Z	3308 A-2RS1
45	85	30,2	51	39	1,63	7 500	5 300	0,63	3209 A-2Z	3209 A-2RS1
	100	39,7	75	53	2,24	6 700	4 800	1,25	3309 A-2Z	3309 A-2RS1
50	90	30,2	51	39	1,66	7 000	4 800	0,65	3210 A-2Z	3210 A-2RS1
	110	44,4	90	64	2,75	6 000	4 300	1,70	3310 A-2Z	3310 A-2RS1
55	100	33,3	60	47,5	2	6 300	4 500	0,91	3211 A-2Z	3211 A-2RS1
	120	49,2	112	81,5	3,45	5 300	3 800	2,65	3311 A-2Z	3311 A-2RS1
60	110	36,5	73,5	58,5	2,5	5 600	4 000	1,20	3212 A-2Z	3212 A-2RS1
	130	54	127	95	4,05	5 000	–	2,80	3312 A-2Z	–
65	120	38,1	80,6	73,5	3,1	4 800	3 600	1,75	3213 A-2Z	3213 A-2RS1
	140	58,7	146	110	4,55	4 500	–	4,10	3313 A-2Z	–
70	125	39,7	88,4	80	3,4	4 500	–	1,90	3214 A-2Z	–
	150	63,5	153	125	5	4 000	–	5,05	3314 A-2Z	–
75	130	41,3	95,6	88	3,75	4 500	–	2,10	3215 A-2Z	–
	160	68,3	176	140	5,5	4 000	–	5,60	3315 A-2Z	–

* The designations of bearings belonging to the SKF Explorer performance class are printed blue. Information on available variants → pages 38 and 39
The bearings in the 32 A and 33 A series are identical with those in the 52 A and 53 A series for the North American market

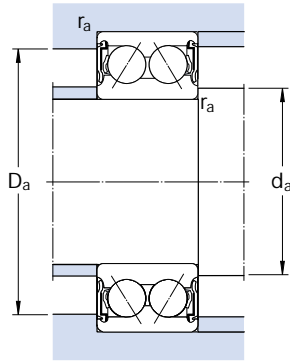

Conversion factors:
Length: 1 mm = 0,0394 in
 1 in = 25,4 mm
Force: 1 N = 0,225 lbf
 1 lbf = 4,4482 N
Mass: 1 kg = 2,205 lb
 1 lb = 0,454 kg

Dimensions

Abutment and fillet dimensions

d	d ₁ ≈	D ₁ ≈	r _{1,2} min	a	d _a min	d _a max	D _a max	r _a max
mm					mm			
10	15,8	25	0,6	16	14,4	15,5	25,6	0,6
12	17,2	27,7	0,6	19	16,4	17	27,7	0,6
15	20,2 23,7	30,7 35,7	0,6 1	21 24	19,4 20,6	20 23,5	30,7 36,4	0,6 1
17	23,3 25,7	35 40,2	0,6 1	23 28	21,4 22,6	23 25,5	35,6 41,4	0,6 1
20	27,7 29,9	40,9 44	1 1,1	28 30	25,6 27	27,5 29,5	41,4 45	1 1
25	32,7 35,7	45,9 53,4	1 1,1	30 36	30,6 32	32,5 35,5	46,4 55	1 1
30	38,7 39,8	55,2 64,1	1 1,1	36 42	35,6 37	38,5 39,5	56,4 65	1 1
35	45,4 44,6	63,9 70,5	1,1 1,5	42 47	42 44	45 44,5	65 71	1 1,5
40	47,8 50,8	72,1 80,5	1,1 1,5	46 53	47 49	47 50,5	73 81	1 1,5
45	52,8 55,6	77,1 90	1,1 1,5	49 58	52 54	52,5 55,5	78 91	1 1,5
50	57,8 62	82,1 99,5	1,1 2	52 65	57 61	57,5 61,5	83 99	1 2
55	63,2 68,4	92,3 109	1,5 2	57 72	63 66	63 68	91 109	1,5 2
60	68,8 73,4	101 118	1,5 2,1	63 78	68,5 72	68,5 73	101 118	1,5 2
65	76,3 78,5	113 130	1,5 2,1	71 84	74 77	76 78,5	111 128	1,5 2
70	82 84,2	118 139	1,5 2,1	74 89	79 82	82 84	116 138	1,5 2
75	84,6 88,8	123 147	1,5 2,1	77 97	84 87	84 88,5	121 148	1,5 2

Other SKF angular contact ball bearings

Precision angular contact ball bearings

SKF manufactures high-precision angular contact ball bearings for the machine tool industry. These radial angular contact ball bearings are available as series 719, 70 and 72 with two different contact angles. For additional information please ask for our catalogue "High-precision bearings".

Four-point contact ball bearings

Four-point contact ball bearings are single row angular contact ball bearings having raceways that are so designed that the bearings can support axial loads acting in both directions. They take up less space axially than double row bearings.

They are designed to accommodate loads, which are predominantly axial and in many applications they are used as thrust bearings together with cylindrical roller bearings that take the radial loads. For additional information on these bearings, consult the "SKF General Catalogue" or the "SKF Interactive Engineering Catalogue" on CD-ROM or online at www.skf.com.

Hybrid bearings

Angular contact ball bearings are also manufactured as hybrid bearings. These bearings combine steel rings with ceramic balls. They are typically used in applications where there is inadequate lubrication, excessive amounts of contamination or stray electrical currents. Even under poor lubrication conditions there is no metal-to-metal contact between the raceways and balls because of the ceramic material.

In these difficult application conditions, hybrid bearings can attain a service life 3 to 30 times longer than a comparable all-steel bearing.

Angular contact thrust ball bearings

High axial stability is important for bearings in precision roller or ball screws. The manufacturing quality of SKF angular contact thrust ball bearings, their running accuracy and low friction contribute to their outstanding positioning accuracy of precision screws. You can find additional information in the SKF catalogue "High-precision bearings".



Electrically insulated bearings

To insulate bearings in electrical drives from stray currents, SKF INSOCOAT® bearings can be used. Available only from SKF, this ceramic coating is applied to the outer or inner ring of bearings used in electrical applications. For additional information on SKF INSOCOAT bearings, contact your local SKF representative. You can also find more information in the "SKF General Catalogue" or the "SKF Interactive Engineering Catalogue" on CD-ROM or online at www.skf.com.

NoWear® bearings

NoWear bearings consist of steel rings and rolling elements, but the rolling elements and, if necessary, the raceways are coated with a low friction

ceramic coating. NoWear bearings are typically used in applications where there are special operating conditions like high speeds with low loads, poor lubrication or high levels of contamination. For additional information about NoWear bearings, reference should be made to the "SKF General Catalogue" or the "SKF Interactive Engineering Catalogue" on CD-ROM or online at www.skf.com.

Application-specific bearing units

SKF manufactures optimized angular contact ball bearing units for special applications. They can be, for example, double row units with different contact angles or units with flanges for quick installation, sealed and lubricated for life. For application-specific units, please contact your SKF representative.

Special designs for the automotive industry

Angular contact ball bearings can be adapted easily to new applications. The automotive industry uses this characteristic to its advantage in clutches, motors, drives, steering assemblies and hub units.

SKF manufactures complete hub units in a large variety of designs. Clutch release bearings and wire race ball bearings for steering columns also belong to the programme.



SKF - The knowledge engineering company

The business of the SKF Group consists of the design, manufacture and marketing of the world's leading brand of rolling bearings, with a global leadership position in complementary products such as radial seals. SKF also holds an increasingly important position in the market for linear motion products, high precision aerospace bearings, machine tool spindles, plant maintenance services and is an established producer of high-quality bearing steel.

The SKF Group maintains specialized businesses to meet the needs of the global marketplace. SKF supports specific market segments with ongoing research and development efforts that have led to a growing number of innovations, new standards and new products.

SKF Group has global ISO 14001 environmental certification. Individual divisions have been approved for quality certification in accordance with either ISO 9000 or appropriate industry specific standards.

Some 80 manufacturing sites worldwide and sales companies in 70 countries make SKF a truly international corporation. In addition, our 7 000 distributor and dealer partners around the world, e-business marketplace and global distribution system put SKF close to customers for the supply of both products and services. In essence, SKF solutions are available wherever and whenever our customers need them.

Overall, the SKF brand now stands for more than ever before. It stands for the knowledge engineering company ready to serve you with world-class product competences, intellectual resources and the vision to help you succeed.



Harnessing wind power

The growing industry of wind-generated electric power provides an environmentally compatible source of electricity. SKF is working closely with global industry leaders to develop efficient and trouble-free turbines, using SKF knowledge to provide highly specialized bearings and condition monitoring systems to extend equipment life in the extreme and often remote environments of wind farms.

Developing a cleaner cleaner

The electric motor and its bearings are the heart of many household appliances. SKF works closely with appliance manufacturers to improve their product's performance, cut costs and reduce weight. A recent



example produced a new generation of vacuum cleaners with substantially more suction. SKF's knowledge in small bearing technology is also applied to manufacturers of power tools and office equipment.



Delivering asset efficiency optimization

To optimize efficiency and boost productivity, many industrial facilities outsource some or all of their maintenance services to SKF, often with guaranteed performance contracts. Through the specialized capabilities and knowledge available from

SKF Reliability Systems, SKF provides a comprehensive range of asset efficiency services, from maintenance strategies and engineering assistance, to operator-driven reliability and machine maintenance programs.



Creating a new “cold remedy”

In the frigid winters of northern China, sub-zero temperatures can cause rail car wheel assemblies and their bearings to seize due to lubrication starvation. SKF created a new family of synthetic lubricants formulated to retain their lubrication viscosity even at these extreme bearing temperatures. SKF's knowledge of lubricants and friction are unmatched throughout the world.



Planning for sustainable growth

By their very nature, bearings make a positive contribution to the natural environment. Reduced friction enables machinery to operate more efficiently, consume less power and require less lubrication. SKF is continually raising the performance bar, enabling new generations of high-efficiency products and equipment. With an eye to the future, SKF's global policies and manufacturing techniques are planned and implemented to help protect and preserve the earth's limited natural resources. We remain committed to sustainable, environmentally responsible growth.



Evolving by-wire technology

SKF has unique expertise and knowledge in fast growing by-wire technology, from fly-by-wire, to drive-by-wire, to work-by-wire. SKF pioneered practical fly-by-wire technology and is a close working partner with all aerospace industry leaders. As an example, virtually all aircraft of the Airbus design use SKF by-wire systems for cockpit flight control. SKF is also a leader in automotive drive-by-wire,

having jointly developed the revolutionary Filo and Novanta concept cars which employ SKF mechatronics for steering and braking. Further by-wire development has led SKF to produce an all-electric forklift truck which uses mechatronics rather than hydraulics for all controls.



Maintaining a 320 km/h R&D lab

In addition to SKF's renowned research and development facilities in Europe and the United States, Formula One car racing provides a unique environment for SKF to push the limits of bearing technology. For over 50 years, SKF products, engineering and knowledge have helped

make Scuderia Ferrari a formidable force in F1 racing. (The average racing Ferrari utilizes more than 150 SKF components.) Lessons learned here are applied to the products we provide to automakers and the aftermarket worldwide.

® SKF, INSOCOAT and NoWear are registered trademarks of the SKF Group.

™ Total Shaft Solutions and Asset Efficiency Optimization are trademarks of the SKF Group.

© Copyright SKF 2003

The contents of this publication are the copyright of the publisher and may not be reproduced (even extracts) unless permission is granted. Every care has been taken to ensure the accuracy of the information contained in this publication but no liability can be accepted for any loss or damage whether direct, indirect or consequential arising out of the use of the information contained herein.

Publication **5105/I E** · September 2003

Printed in Sweden on environmentally friendly, chlorine-free paper (Multiart Silk) by Hyltebruks Tryckeri AB.