

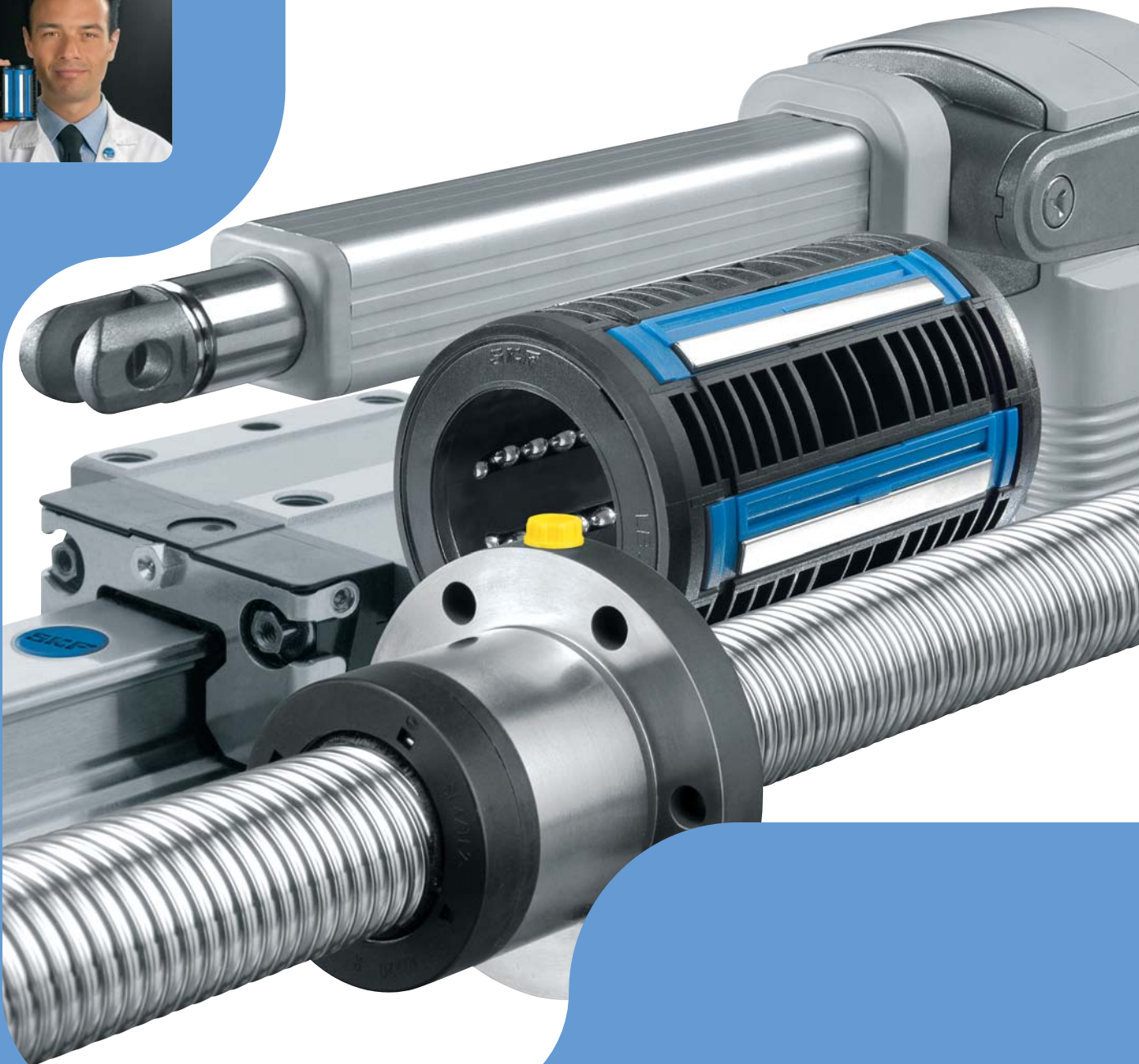

Linear motion standard range



Contents

(by chapters)

Made by SKF® stands for excellence. It symbolises our consistent endeavour to achieve total quality in everything we do. For those who use our products, “Made by SKF” implies three main benefits:

Reliability – based on modern, efficient products, our worldwide application know-how, optimised materials, forward-looking designs and the most advanced production techniques.

Cost effectiveness – resulting from the favourable ratio between our product quality plus service facilities, and the purchase price of the product.

Market lead – which you can achieve by taking advantage of our products and services. Increased operating time and reduced downtime, as well as improved output and product quality are the keys to a successful partnership.



1 General 11

2 Guiding systems 15

Shaft guidings	16
Ordering key for LBBR - compact series	20
LBBR Compact series	21
LBBR ../HV6 Corrosion resistant type	21
LPBR Linear plain bearings	22
LUHR Linear ball bearing units	22
LUHR PB Linear plain bearing units	23
LUJR Linear ball bearing units	23
LTBR Tandem linear ball bearing units	23
LSHS Shaft blocks for compact series	24
LTDR Duo linear ball bearing units	24
LQBR Quadro linear ball bearing units	24
LEBS Tandem shaft blocks	25
Appropriate special seals	25
Ordering key for LBBR - standard series	26
LBCD Standard series 3, closed type	28
LBCR Standard series 3, closed type	28
LPAR Linear plain bearings, closed type	29
LUCD Single units, self-aligning, closed type	29
LUCE Single units, self-aligning, closed type	30
LUCR Single units, closed type	30
LUCR PA Single plain bearing units, closed type	31
LUCS Single units, closed type	31
LUND Single units, self-aligning, closed type	32
LUNE Single units, self-aligning, closed type	32
LVCD Flanged self-aligning units	33
LVCR Flanged units	33
LSCS Shaft blocks	34
LSNS Shaft blocks	34
LTCD Tandem units, self-aligning, closed type	35
LTCR Tandem units, closed type	35
LQCD Quadro units, self-aligning, closed type	36
LQCR Quadro units, closed type	36
LEAS Tandem shaft blocks, closed type	37
LBCF Standard series 3, open type	38
LBCT Standard series 3, open type	38
LBHT Heavy-load type, open type	39
LPAT Linear plain bearings, open type	39
LUCF Single units, self-aligning, open type	40
LUCT Single units, open type	40
LUCT BH Single heavy-load units, open type	41
LUCT ..PA Single units, open type	41
LUNF Single units, self-aligning, open type	42
LTCF Tandem units, self-aligning, open type	42
LTCT Tandem units, open type	43

LQCF Quadro units, self-aligning, open type	43	Miniature profile rail guides	74
LQCT Quadro units, open type	44	Ordering key for miniature profile rail guides	77
LRCB/LRCC Shaft supports, open type	44	LLMHR Standard rails	78
Precision shafts	46	LLMWR Wide rails	78
LJM Precision shafts, steel	47	LLMHC ..TA Standard carriages	78
LJMH Hard chromium plated precision shafts	47	LLMWC ..TA Carriages for wide rails	79
LJMR Precision shafts, stainless steel	47	LLMHC ..LA Long carriages	79
LJMS Precision shafts, stainless steel	47	LLMWC ..LA Long carriages for wide rails	79
LJT Hollow shafts, high grade steel	47	Precision rail guides	80
Ordering key for precision shafts	48	ACS Anti-creeping-system for LWRE	80
ESSC 1 Precision shaft configurations	49	Ordering key for precision rail guides	81
ESSC 2 Precision shaft configurations	49	LWR Precision rail guides	82
ESSC 3 Precision shaft configurations	49	LWRB Precision rail guides	82
ESSC 4 Precision shaft configurations	49	LWAL Crossed roller assemblies, aluminium cages	82
ESSC 5 Precision shaft configurations	50	LWJK Ball assemblies, plastics cages	82
ESSC 6 Precision shaft configurations	50	LWAK Crossed roller assemblies, plastics cages	82
ESSC 7 Precision shaft configurations	50	LWERA End pieces	82
ESSC 8 Precision shaft configurations	51	LWGD Special attachment screws	82
ESSC 9 Precision shaft configurations	51	LWR 3/6 .. Kit Precision rail guide kits	83
ESSC 10 Precision shaft configurations	51	LWRB 1 Precision rail guides	84
Design and basic data	52	LWRB 2 Precision rail guides	84
Linear ball bearing table without drive	54	LWR 3 Precision rail guides	85
Ordering key for linear ball bearing table without drive	55	LWR 6 Precision rail guides	85
LZBU ..A-2LS Quadro linear tables	56	LWR 9 Precision rail guides	86
LZBU ..B-2LS Quadro linear tables	57	LWR 12 Precision rail guides	86
LZAU ..2LS Quadro linear tables	58	LWRE Precision rail guides	87
Linear guiding system Speedi-Roll	60	LWAKE Crossed roller assemblies, plastics cage	87
Ordering key for Speedi-Roll	61	LWERE End pieces	87
LLEHR Rails	62	LWGD Special attachment screws	87
LLEHC ..HZ/HC Standard carriages	62	LWRE 3/4/6 .. Kit Precision rail guide kits	88
LLEHC ..LZ/LC Long carriages	63	LWRE 3/4/6 .. ACS - Kit Precision rail guide kits with ACS	89
LLEHM End stops	63	LWRE 3 Precision rail guides	90
LLEHX Roller covers	63	LWRE 2211 Precision rail guides	90
LLEHE ..Z Rollers	64	LWRE 4 Precision rail guides	91
Profile rail guides	65	LWRE 6 Precision rail guides	91
Ordering key for profile rail guides	66	LWRE 9 Precision rail guides	92
Accessories for profile rail guides	67	LWRE 3 ACS Precision rail guides with ACS	92
LLRHS ..SA	68	LWRE 2211 ACS Precision rail guides with ACS	93
LLRHS ..A	68	LWRE 4 ACS Precision rail guides with ACS	93
LLRRS ..LA	68	LWRE 6 ACS Precision rail guides with ACS	94
LLRHS ..SU	70	LWRE 9 ACS Precision rail guides with ACS	94
LLRHS ..U	70	LWRM Precision rail guides	95
LLRHS ..LU	70	LWRV Precision rail guides	95
LLRHS ..R	72	LWHW Needle roller assemblies, aluminium cage	95
LLRHS ..LR	72	LWEARM End pieces	95
		LWEARV End pieces	95
		LWGD Special attachment screws	95

LWRM 6 Precision rail guides	96
LWRV 6 Precision rail guides	96
LWRM 9 Precision rail guides	96
LWRV 9 Precision rail guides	96
LWM / LWV Precision rail guides	97
LWHW Needle roller assemblies, aluminium cages	97
LWEAM End pieces	97
LWEAV End pieces	97
LWGD Special attachment screws	97
LWM 3015 / LWV 3015 Precision rail guides	98
M3 DIN 84	98
LWM 4020 / LWV 4020 Precision rail guides	98
M5 DIN 84	98
LWM 5025 / LWV 5025 Precision rail guides	99
M6 DIN 84	99
LWM 6035 / LWV 6035 Precision rail guides	99
M6 DIN 84	99
LWM 7040 / LWV 7040 Precision rail guides	100
M6 DIN 84	100
LWM 8050 / LWV 8050 Precision rail guides	100
M6 DIN 84	100

Ordering key for roller screws	131
Planetary roller screws	132
BRC Range	132
FLRBU/BRC Range	133
SRC Range	134
SRF Range	136
TRU / PRU Range	138
TRK / PRK Range	141

Recirculating roller screws	144
BVC Range	144
FLRBU/BVC	145
SVC Range	146
PVU Range	147
PVK Range	148
FLRBU Accessories for roller screws	149

Symbols	151
----------------------	------------

4 Actuation systems 153

About actuation systems	153
Selection guide	154
Combinations of actuators, control units and operating units	165

Telescopic pillars	167
TELEMAG: principle	167
TGC	168
THC	169
THG	170
TLC	171
TLG	172
TLT	173
TMS	174
TELESMART: principle	176
TMD	177
TMA	178
TXG	179
Maggear	180

Linear actuators	182
CAT: principle	182
CAT 21B	183
CAT 33H	184
CAT 33	186
CAT 32B	188
Page with all detailed drawings of CAT 32B, CAT 33 and CAT 33H	190
CAP: principle	192
CAP 32	193
CAP 43A	194
CAP 43B	195
Detailed drawings of attachments and motor options for CAP 43 and motor options for CAP 32	196
CAR: principle	197
CAR 22	198

3 Driving systems 103

Ball and roller screws	103
-------------------------------------	------------

How to orientate your choice	104
---	------------

Ball screws	105
--------------------------	------------

Ordering key for ball screw	106
SD/BD Miniature screws	107
SH Miniature screws	107
SX/BX Universal screws	108
FHRF Round flanges (for SX nuts only)	109
FHSF Square flanges (for SX nuts only)	109
SN/BN Precision screw	110
SND/BND Precision screw, DIN standard	110
PN Precision screw, preloaded	111
PND Precision screw, DIN standard, preloaded	111
SL/BL Long lead screws	112
SLD/BLD Long lead screws, DIN standard	112
Rotating nut	114
Shaft and combinations for rolled ball screws	116
PLBU Plummer bearing units	120
FLBU Flanged bearing units	120
BUF End bearing units	121
FBS - Q Support bearing cartridge units (4 bearings matched in set)	121
FBS - D Support bearing cartridge units (2 bearings matched in set)	121
Ground ball screws	122
Ordering key for ground ball screws	123
PGFE screw with DIN double flanged preloaded nuts	124
PGFJ screw with DIN flanged nuts with internal preload	124

Roller screws	126
----------------------------	------------

Planetary roller screws: principle	128
Recirculating roller screws: principle	129

CAR 32	199	CRAB 05: principle	256
CAR 40	200	CRAB 05	255
CARN 32	201	Control units: principle	258
CCBR 32	202	KOM1	259
MAGFORCE: principle	203	KOM2	260
GTD	204	KOM3	261
WSP	205	KOM6	262
ASM	206	MCU	263
DSP	207	LD	264
SKG	208	SEM	265
SKD	209	CAFC 04	266
STW	210	CAFCM	267
STG	211	CAEN15	267
STD	212	CAEN10R	268
SKS/SKA	213	CAEV	268
SLS	214	CAED ANR	268
ECOMAG: principle	216	CAED	269
ECO	216	CAEP	269
CALA 36: principle	218	CAEL	269
CALA 36A	219	BCU	270
MATRIX: principle	220	Hand switches: principle	271
MAX1	221	EHA1	272
MAX3	222	EHA2	273
MAX6	223	EHA3	274
CARE 33: principle	224	IHA1	275
CARE 33	224	EHE1/3	276
RUNNER: principle	226	EHE6	277
RU20/RU21/RU22	227	PHC	278
CAFM: principle	228	CAFH	278
CAFM	228	CAES	278
CAFS: principle	230	Foot switch: principle	279
CAFS	230	ST	280
MAGPUSH: principle	232	PFP	281
GC 84 UB	233	CAFHF	281
LC .. UB	233	Desk switches: principle	282
GC 84 TL	234	ST	283
HC 85 UB	235	LD	284
MAGTOP CS: principle	236	CAFHT	285
CS10	237	PAM	285
CS20	238	Junction box	286
CS31	239	CAFR	286
CS40	240	Easy3: principle	287
CS50	241	EASY3-02 In-line actuator package	288
CS60	242	EASY3-03 Low-noise actuator package	288
CS70	243	EASY3-04 Low-noise actuation system	289
VARIMAG CC: principle	244	EASY3-05 Low-noise actuation system	289
CC10	245	EASY3-10 Integrated actuation system	290
CC20	246	EASY3-11 Integrated actuation system	290
CC30	247	EASY3-12 Flexible actuation system	291
CC40	248	EASY3-13 Flexible actuation system	291
CC50	249	Guiding tube sets FRE: principle	292
MAGRACK CK: principle	250	FRE	293
CK..	250		
CK - 24 VDC	251		
CK - 230 VAC	252		
Rotary actuators	254		
CRAB 17: principle	254		
CRAB 17	257		

Spare parts	294	RSS Precision slides: principle	309
Type codes for accessories and spare parts:		LZBB/LZAB Linear ball bearing tables: principle	309
CAR 22	294	LTP Linear axes, type PICO: principle	309
CAR 32	294	LTB Profile rail guide slides: principle	309
CAR 40	295	Ordering key for miniature slides	312
CAP 32	295	LZM Miniature slides	313
CARN 32	296	Ordering key for standard slides	315
CCBR 32	296	GCL Standard slides, steel version	316
CAT 33	296	GCLA Standard slides, aluminium version	318
CAT 33H	297	RM Standard slides	320
CAT 32B	298	Ordering key for slides, tables and compact cross tables	321
CAT 43	298	SSM/SSK Dovetail slides	322
Drawings spare parts	299	TO/TS Compact cross tables	325
Glossary and definitions	302	RSM/RSK Precision slides	326
		RSS Precision slides	328
		Ordering key for linear ball bearing table with drive	331
		LZBB Linear ball bearing tables, ball screw	332
		LZAB Linear ball bearing tables, ball screw	333
		Ordering key for linear axes, type PICO	334
		Technical informations	335
		LTP 60	336
		LTP 80	336
		Drive concepts	338
		Ordering key for profile rail guide slides	341
		LTB Profile rail guide slides	342
		SKF – The knowledge engineering company	348
5 Positioning systems	307		
General	307		
LZM miniature slides: principle	307		
GCL Standard slides: principle	308		
GCLA Standard slides: principle	308		
RM Standard slides: principle	308		
SSM/SSK Dovetail slides: principle	308		
TO/TS Compact cross tables: principle	308		
RSM / RSK Precision slides: principle	308		

Contents

(by alphabetical order)

A

About actuation systems	153
Accessories for profile rail guides	67
Actuation systems	153
Anti-creeping-system (ACS)	80
Appropriate special seals	25
ASM	206

B

Ball and roller screws	103
Ball screws	105
BCU	270
BRC	132
BUF	121
BVC	144

C

CAED	269
CAED ANR	268
CAEL	269
CAEN10R	268
CAEN15	267
CAEP	269
CAES	278
CAEV	268
CAFC 04	266
CAFCEM	267
CAFH	278
CAFHF	281
CAFHT	285
CAFME: principle	228
CAFME	228
CAFR	286
CAFS: principle	230
CAFS	230
CALA 36: principle	218
CALA 36A	219
CAP: principle	192
CAP 32	193, 295
CAP 43A	194, 298
CAP 43B	195, 298
CAR: principle	197
CAR 22	198, 294
CAR 32	199, 294

CAR 40	200, 295
CARE 33: principle	224
CARE 33	224
CARN 32	201, 296
CAT: principle	182
CAT 21B	183
CAT 32B	188, 298
CAT 33	186, 296
CAT 33H	184, 297
CC10	245
CC20	246
CC30	247
CC40	248
CC50	249
CCBR 32	202, 296
CK	250
CK - 230 VDC	251
CK - 24 VAC	252
Combination of actuators, control unit and operating units	165
Control units: principle	258
CRAB 05	257
CRAB 05: principle	256
CRAB 17	254
CRAB 17: principle	254
CS10	237
CS10	245
CS20	246
CS30	247
CS40	248
CS50	249

D

Design and basic data	52
Desk switches: principle	282
Detailed drawings of attachments and motor options for CAP 43 and motor options for CAP 32	196
Drawings spare parts	299
Drive concepts	338
Driving systems	103
DSP	207

E

Easy3: principle	287
EASY3-02	288

EASY3-03	288
EASY3-04	289
EASY3-05	289
EASY3-10	290
EASY3-11	290
EASY3-12	291
EASY3-13	291
ECO	216
ECOMAG: principle	216
EHA1	272
EHA2	273
EHA3	274
EHE1/3	276
EHE6	277
ESSC 1	49
ESSC 2	49
ESSC 3	49
ESSC 4	49
ESSC 5	50
ESSC 6	50
ESSC 7	50
ESSC 8	51
ESSC 9	51
ESSC 10	51

F

FBS - D	121
FBS - Q	121
FHRF	109
FHSF	109
FLBU	120
FLRBU	149
FLRBU/BRC	133
FLRBU/BVC	145
Foot switch: principle	279
FRE	293

G

GC 84 TL	234
GC 84 UB	233
GCL	316
GCL: principle	308
GCLA	318
GCLA: principle	308
General	11
Glossary and definitions	302
Ground ball screws	122
GTD	204
Guiding systems	15
Guiding tube sets FRE: principle	292

H

Hand switches: principle	271
--------------------------	-----

HC 85 UB	235
How to orientate your choice	104

I

IHA1	275
------	-----

J

Junction box	286
--------------	-----

K

KOM1	259
KOM2	260
KOM3	261
KOM6	262

L

LBBR	21
LBBR ../HV6	21
LBCD	28
LBCF	38
LBCR	28
LBCT	38
LBHT	39
LC .. UB	233
LD	264, 284
LEAS	37
LEBS	25
Linear actuators	182
Linear ball bearing table without drive	54
Linear guiding system Speedi-Roll	60
LJM	47
LJMH	47
LJMR	47
LJMS	47
LJT	47
LLEHC ../HZ/HC	62
LLEHC ../LZ/LC	63
LLEHE ../Z	64
LLEHM	63
LLEHR	62
LLEHX	63
LLMHC ../LA	79
LLMHC ../TA	78
LLMHR	78
LLMWC ../LA	79
LLMWC ../TA	79
LLMWR	78
LLRHS ../A	68
LLRHS ../LR	72
LLRHS ../LU	70
LLRHS ../R	72

Ground ball screws	123
LBBR – compact series	20
LBBR – standard series	26
Linear axes, type PICO	334
Linear ball bearing table with drive	331
Linear ball bearing table without drive	55
Miniature profile rail guides	77
Miniature slides	312
Precision rail guides	81
Precision shafts	48
Profile rail guide slides	341
Profile rail guides	66
Roller screws	131
Slides, tables and compact cross tables	321
Speedi-Roll	61
Standard slides	315

SEM	265
SD/BD	107
SH	107
Shaft and combinations for rolled ball screws	116
Shaft guiding	16
SKD	209
SKG	208
SKS/SKA	213
SL/BL	112
SLD/BLD	112
SLS	214
SN/BN	110
SND/BND	110
Spare parts	294
SRC	134
SRF	136
SSM/SSK	322
SSM/SSK: principle	308
ST	280, 283
STD	212
STG	211
STW	210
SVC	146
SX/BX	108
Symbols	151

P

Page with all detailed drawings of CAT 32B, CAT 33 and CAT 33H	190
PAM	285
PFP	281
PGFE	124
PGFJ	124
PHC	278
Planetary roller screws	132
Planetary roller screws: principle	128
PLBU	120
PN	111
PND	111
Positioning systems	307
Precision rail guides	80
Precision shafts	46
Profile rail guides	65
PVK	148
PVU	147

R

Recirculating roller screws	144
Recirculating roller screws: principle	129
RM	320
RM: principle	308
Roller screws	126
Rotary actuators	254
Rotating nut	114
RSM/RSK	326
RSM/RSK: principle	308
RSS	328
RSS: principle	309
RU20/RU21/RU22	227
RUNNER: principle	226

S

Selection guide	154
-----------------------	-----

T

TELEMAG: principle	167
Telescopic pillars	167
TELESMART: principle	176
TGC	168
THC	169
THG	170
TL	111
TLC	171
TLD	111
TLG	172
TLT	173
TMA	178
TMD	177
TMS	174
TN	107
TND	108
TO/TS	325
TO/TS: principle	308
TRK/PRK	141
TRU/PRU	138
TXG	179
Type codes for accessories and spare parts	294

V

VARIMAG CC: principle	244
-----------------------------	-----

W

WSP	205
-----------	-----

General

SKF Group

SKF is the leading global supplier of products, customer solutions and services in the business of rolling bearings and seals. The Group's position and its very strong brand awareness are due to its own competence in providing products and services able to create value for all customers. SKF's main skills include technical support, maintenance services, condition monitoring and training. SKF also holds an increasingly important position in the market for linear motion products, as well as high precision bearings, spindles and spindle services for the machine tool industry, lubrication systems, and is an established producer of bearing steel.

The SKF business is organized into five divisions: Industrial, Automotive, Electrical, Service and Aero and Steel. Each division serves a global market, focusing on its specific customer segments.

To successfully create added value for all customer belonging to these different

communities, SKF holds a deep and full understanding of what customers specifically require and need, regarding to products and services. Original and most valuable equipment manufacturers value how SKF's knowledge and technology can make their own products more competitive. For end-users, the aim is to ensure the maximum utilization of their assets in order to increase their productivity and profitability. In the aftermarket, the most important elements are to exactly know what kind of products the customer needs and to have these products always and immediately available.

The key factor is one only: "Knowledge". Learning and competence developing is a never-ending journey and SKF's competitive advantage is directly linked to its own technological know-how increased throughout decades.

Linear Motion from SKF

Linear Motion from SKF is a business unit specialised in manufacturing and sales of a wide range of high precision components, units and systems for linear movements, providing solutions for guiding, driving, actuation and positioning.

SKF Linear Motion provides products and assistance through a specialised sales companies network all around the world, in order to be always close to customers, supporting them in their everyday needs and making Linear Motion's technology totally meet their requests for any application use.

Such an organised support network and technological knowledge are available 24 hours a day on www.linearmotion.skf.com and the whole wide standard product range is by customers' hands with Standard delivery range catalogue.

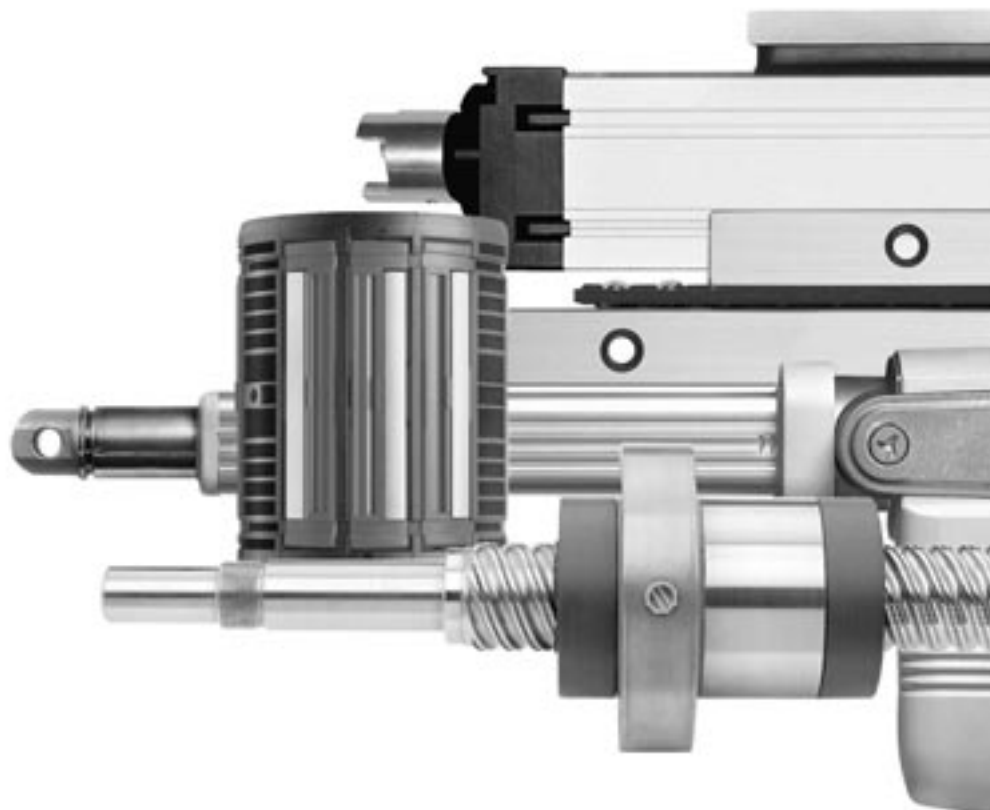

Easy Tools

Selecting, defining and purchasing Linear Motion from SKF products has never been so simple. Four tools to satisfy all selection requests of SKF solutions, with the aim to make all of our proposals “easy to buy, easy to sell.”

Standard delivery range

The encyclopedia of the Linear Motion. The Standard delivery range catalogue introduces over three hundred pages dense of information on all the standard products, with the related very clearly structured tables, to help the customer to select the right solution and the correct definition of the product to order.

Electronic Price List

For a simple and immediate price calculation and for the configuration of the desired solution, the “Electronic Price list” CD-ROM , realized in four languages, is the ideal tool: quick, precise and efficient.

Linear Motion Website

To find the whole Linear Motion products and services range, it is only to connect to:

www.linearmotion.skf.com.

All the information that customers can desire, all the “customer communities” and a wide range of functionalities: all rigorously on-line.

Linear Motion Webshop

Do product configuring and ordering ask for too much time? No more, with the Linear Motion Webshop. Thanks to this precious tool, the ordering and delivery time is reduced to the least. Then, less time means less costs.

PDF catalogues online

In addition to this Standard delivery range catalogue we have all product brochures available as pdf document on the internet.

www.linearmotion.skf.com/doc



Defining



Selection



Configuration



Accessibility



Customization



Ordering



How to handle

This publication consists of 4 chapters divided as follows:

- Guiding systems
- Driving systems
- Actuation systems
- Positioning systems

The chapters are arranged from the most simple, the guiding, through to the most complex, the positioning, which consists of parts of the other components.

Each linear solution is introduced by an overview, which makes it easy to select the right product.

The different subjects are contained in the separate chapters, starting with a brief general description followed by the specific ordering key and the drawings with the data tables.

If a subject is divided into several sections, the corresponding ordering key is located at the beginning of each section, followed by the pages with tables and

pictures of that section (for example, on page 20 and on page 26 there are two ordering keys for the Linear ball bearings but they belong to different families: compact series and standard series).

The composition of the ordering keys is not univocal, due to the structural difference of the products, instead it follows the type of the individual product.

The procedure to determine the product code to be indicated on the order is as follows:

After identifying the type of product required by examining the relevant pages containing the main data, it is necessary to prepare the code for the order. This may consist of pre-set options, ordering key boxes already filled in (for example: type, colour, etc.) and options that can be selected from several items, empty boxes (for example: design, bearing, nut type, stroke, length, etc.).

In the ordering key the options are set out under the associated subjects, with the indication of the code or the information to be entered (with the measurement restrictions contained in the associated table), the sequence of the ordering key is defined by the thin guiding lines that select the corresponding box.

The individual ordering key may contain indications or special notes.

Examples to show how to fill in are given at the end of each ordering key.

In the chapter for the actuators the selection of the items dynamic load/speed, motor option, is through a further table with several options, located above the ordering key.

An example is given below to show how to prepare the order code for an LZ long linear table.

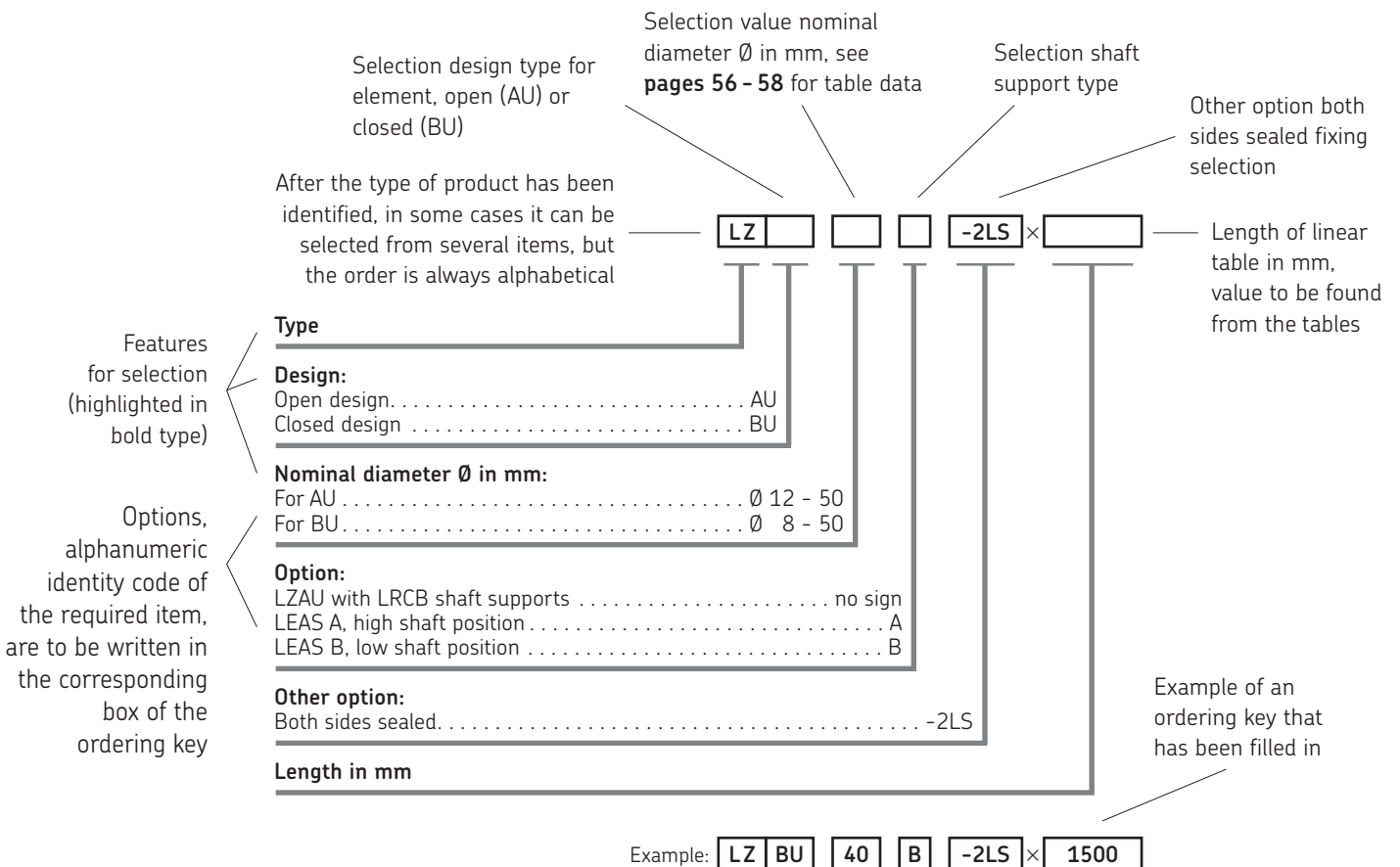



Light, steady and always on the run.



The hummingbird is not only the world's smallest bird but it is also the most stable, thanks to the incredible speed of its wings (eighty pulsations per second) that allow it to be suspended in flight, so allowing itself to feed on the delicious nectar from many of the flowers in Latin America.

The lightness and stability are among the features that have given SKF the inspiration to create lightweight linear ball bearings which are capable of accommodating loads with the greatest efficiency.

The potential derived from such lightness is truly impressive.

Linear motion from SKF
www.linearmotion.skf.com



Guiding systems

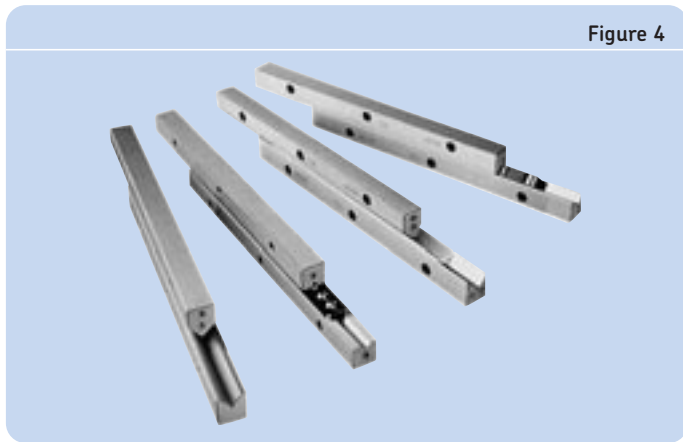
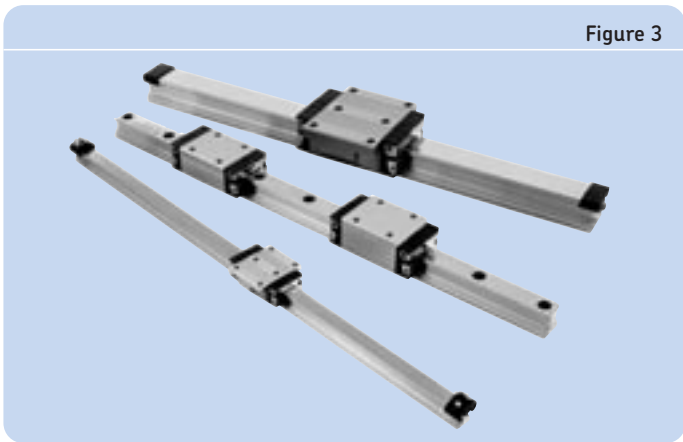
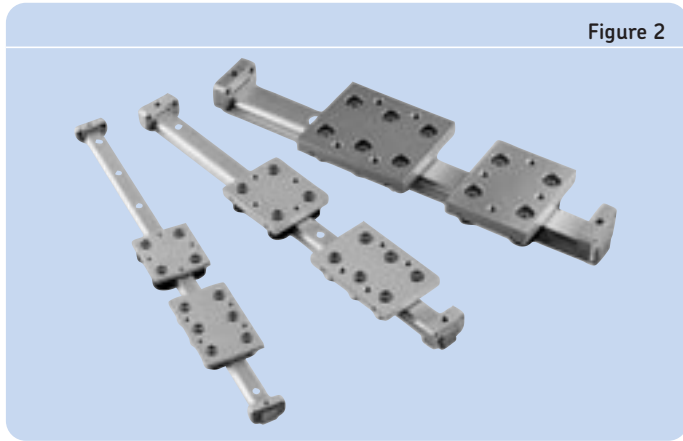
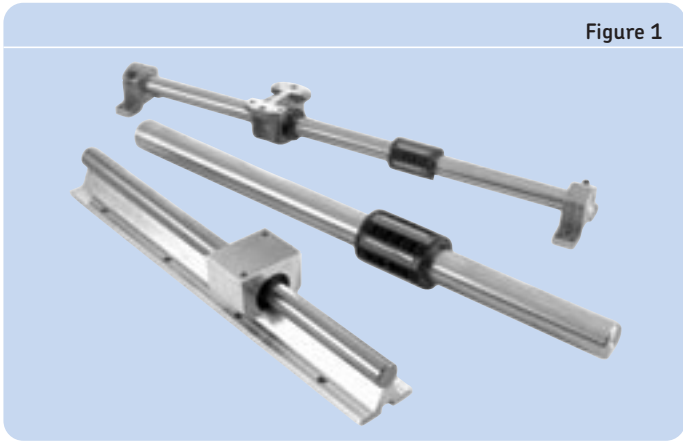

Linear ball bearings (→ **figure 1**), cam roller guides (Speedi-Roll) (→ **figure 2**), profile rail guides (→ **figure 3**), precision

rail guides (→ **figure 4**): limited stroke, very high precision and performance capabilities.

Operating precision (→ Table 1)
Comparison of the different positioning components and systems.

Table 1

Operating precision (µm)	Guiding systems		Driving systems		Actuation systems	Positioning systems
0.1 - 1		Precision rail guides	Roller screws	Linear motors		Standard drives or linear motors with all guiding systems
1 - 10	Linear ball bearings					
10 - 100		Profile rail guides	Ball screws			
100 - 1000		Cam roller guides			Electro-mechanical actuators	

Shaft guidings

Linear ball bearings (→ figures 5, 6 and 7) are bushings with recirculating ball tracks which provide low friction movement and the possibility of unlimited stroke. With the range of linear ball bearings, plain bearings and accessories it is possible to design and build economical and simple linear guiding

systems to suit a wide range of applications. The bearings are available in two size ranges: the compact ISO 1 series and the heavy duty by standard ISO 3 series (→ Table 2).



Figure 5

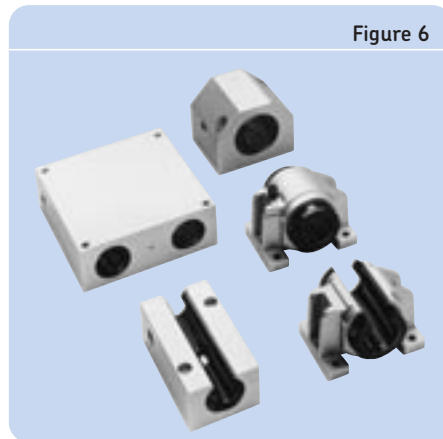

Figure 6

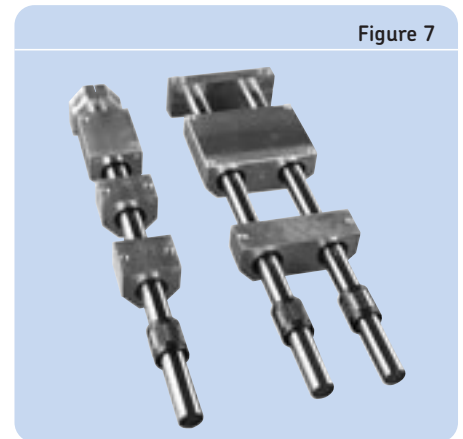

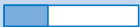



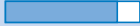



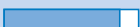















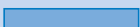









Figure 7

Table 2

	Type		Basic dynamic load rating	Stiffness	Speed	Precision
Linear ball bearings						
Compact	LBBR 					
Standard	LBCR 					
	LBCD 					
	LBCT 					
	LBCF 					
	LBHT 					
Linear plain bearings						
Compact	LPBR 					
Standard	LPAR 					
	LPAT 					
Shafts						
	LJM 		Standard CF 53			
	LJMH 		Hard chromium-plated			
	LJMR 		Corrosion resistant			
	LJT 		Hollow			
	LJMS 		Corrosion resistant			

Compact range

Figure 8



LBBR

Compact linear ball bearings available in standard or corrosion resistant versions

Figure 9

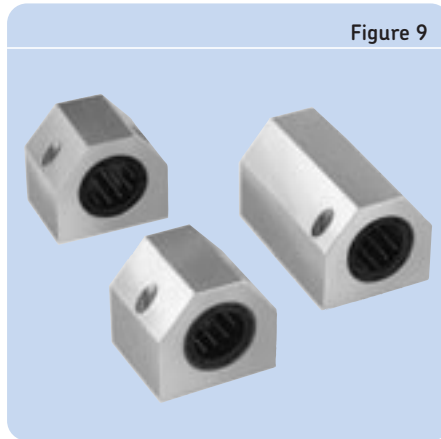

LUHR / LUJR

Linear ball bearing units with either integral seals or G-type seals mounted in the housing

LTBR

Tandem linear ball bearing units with seals

Figure 10

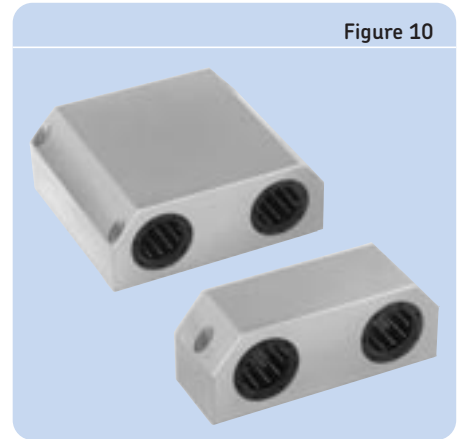

LTDR

Duo linear ball bearing units with seals

LQBR

Quadro linear ball bearing units with seals

Figure 11

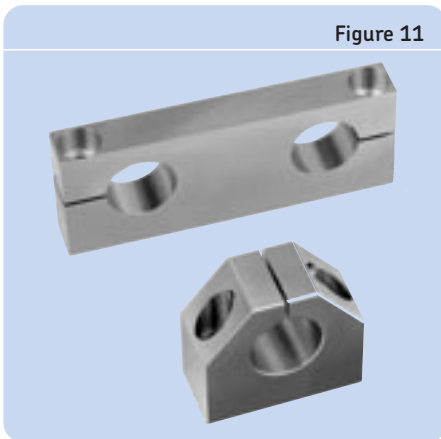

LSHS

Shaft blocks for compact series

LEBS

Tandem shaft blocks suitable for LQBR and LTDR

NB:

In addition to this catalogue we have all product brochures available as pdf document on the internet.

www.linearmotion.skf.com/doc

Standard range

Figure 12

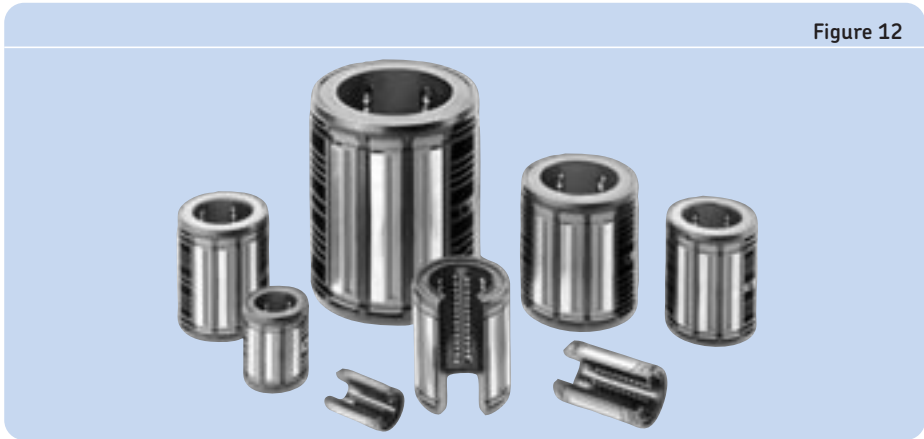

LBCR
Closed linear ball bearings without self-aligning feature

LBCT
Open linear ball bearings, not self-aligning

LBHT
Heavy-load linear ball bearings, open type

LBCD
Self-aligning linear ball bearings, closed type

LBCF
Self-aligning linear ball bearings, open type

NB:
All LBC and LBH Linear ball bearings available in corrosion resistant!

Figure 13



LUCD / LUCE
Self-aligning linear ball bearing units with adjustable preload

LUCF
Open self-aligning linear ball bearing units with adjustable preload

Figure 14

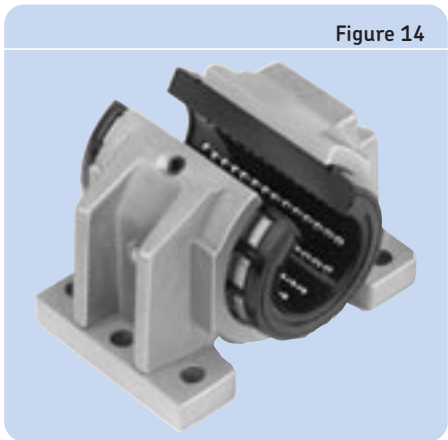

LUCT / BH
Heavy-load linear ball bearing units with adjustable preload

Figure 15



LUND / LUNE
Self-aligning linear ball bearing units with adjustable preload

LUNF
Self-aligning linear ball bearing units, open type with adjustable preload

Figure 16



LTCD / LTCF
Open or closed self-aligning tandem linear ball bearing units

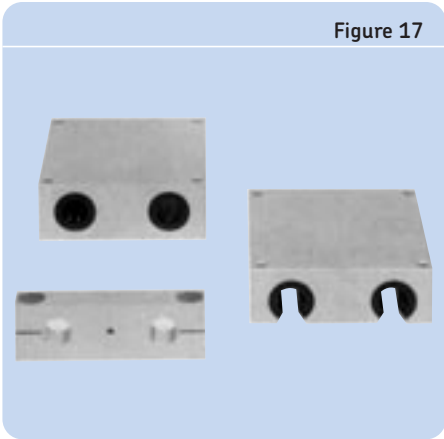

LQCD / LQCF
Open or closed self-aligning quadro linear ball bearing units

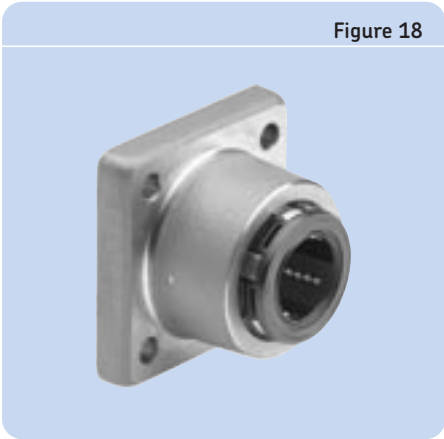

LVCR
Flanged linear ball bearing units

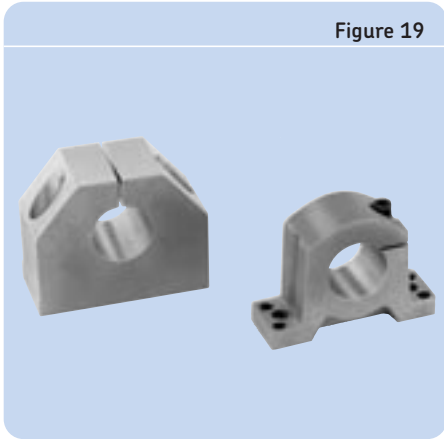

LSCS
Standard shaft blocks suitable for use with all linear bearing units

LSNS
Shaft blocks suitable for use with all linear bearing units

Linear ball bearings / Linear bearing units

Table 3

Designation	ISO serie I Compact		ISO serie III Standard									
	LBBR	LPBR	LBCD .. A	LBCF .. A	LBHT .. A	LBCR .. A	LBCT .. A	LPAR	LPAT	-	-	
Linear bearing unit¹⁾	LUHR	LUHR PB LUJR	LUCD	LUCF LUCE	LUCT BH LUNF	LUCR	LUCT LUCS	LUCR PA	LUCT PA	-	LUCT	
				LUND LUNE							LUCR LUCS	
	LUBR LUER	LUBR PB										
Flanged unit¹⁾	-	-	LVCD	-	-	LVCR	-		-	LVCR	-	
Tandem unit¹⁾	LTBR		LTCB	LTCF		LTCR	LTCT					
Duo unit	LTDR											
Quadro unit¹⁾	LQBR		LQCD	LQCF		LQCR	LQCT			LQCR		
Shaft blocks	LSHS	LSHS	LSCS	- LSNS	- -	LSCS -	- LSNS	LSCS -	- LSNS	LSCS -	- -	
Tandem shaft block	LEBS	-	LEAS	-	-	LEAS	-	-	-	LEAS	-	
Shaft supports	- -	- -	- -	LRCB LRCC	LRCB LRCC	- -	LRCB LRCC	- -	LRCB LRCC	- -	LRAB LRAC	

□ **Standard:** available from stock (changes reserved)
 ■ **Non-standard:** price and delivery time on request

¹⁾ Linear bearing units without seals are available on request only.

LBBR ..

Compact series 1
Linear ball bearings
LBBR (without seals)
-LS with one seal
-2LS with two seals

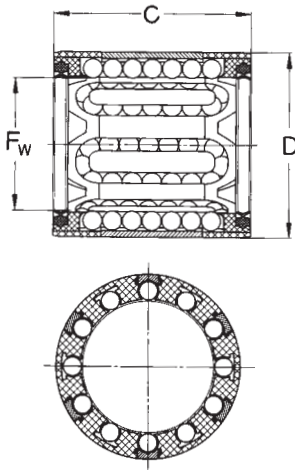

Designations	Dimensions			Basic load ratings	
	F_w	D	C	dynamic C	static C_0
	mm			N	
LBBR 3 (CAS4)*	3	7	10	60	44
LBBR 4 (CAS4)*	4	8	12	75	60
LBBR 5 (CAS4)*	5	10	15	170	129
LBBR 6A	6	12	22 ¹⁾	335	270
LBBR 8	8	15	24	490	355
LBBR 10	10	17	26	585	415
LBBR 12	12	19	28	695	510
LBBR 14	14	21	28	710	530
LBBR 16	16	24	30	930	630
LBBR 20	20	28	30	1160	800
LBBR 25	25	35	40	2120	1560
LBBR 30	30	40	50	3150	2700
LBBR 40	40	52	60	5500	4500
LBBR 50	50	62	70	6950	6300

Example:
LBBR 4 (CAS4)
LBBR 20-LS
LBBR 50-2LS

* Without seal, 4 pieces, packed in cassette (only valid for sizes 3, 4, 5)

¹⁾ Width 22 does not correspond to series 1 in ISO standard 10285

LBBR .. /HV6

Compact series 1
Corrosion resistant bearings
/HV6 without seals
-2LS/HV6 with two seals

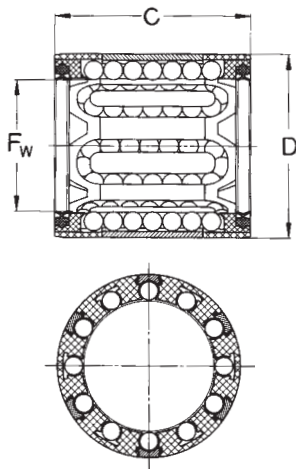

Designations	Dimensions			Basic load ratings	
	F_w	D	C	dynamic C	static C_0
	mm			N	
LBBR 3/HV6 (CAS 4)*	3	7	10	60	44
LBBR 4/HV6 (CAS 4)*	4	8	12	75	60
LBBR 5/HV6 (CAS 4)*	5	10	15	170	129
LBBR 6A/HV6	6	12	22 ¹⁾	335	270
LBBR 8/HV6	8	15	24	490	355
LBBR 10/HV6	10	17	26	585	415
LBBR 12/HV6	12	19	28	695	510
LBBR 14/HV6	14	21	28	710	530
LBBR 16/HV6	16	24	30	930	630
LBBR 20/HV6	20	28	30	1160	800
LBBR 25/HV6	25	35	40	2120	1560
LBBR 30/HV6	30	40	50	3150	2700
LBBR 40/HV6	40	52	60	5500	4500
LBBR 50/HV6	50	62	70	6950	6300

Example:
LBBR 4/HV6 (CAS4)
LBBR 50-2LS/HV6

* Without seal, 4 pieces, packed in cassette (only valid for sizes 3, 4, 5)

¹⁾ Width 22 does not correspond to series 1 in ISO standard 10285

2 Guiding systems

Shaft guidings - compact series

LPBR

Linear plain bearings

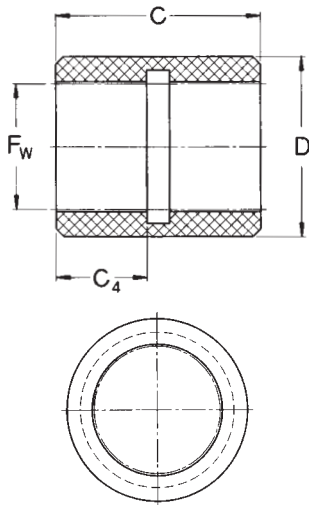

Designations	Dimensions				Basic load ratings		
	F_w	D	C	C_4	dynamic C 0.1 m/s	static C ₀ 4 m/s	
	mm				N		
LPBR 12	12	19.19	28	10	965	24	3350
LPBR 16	16	24.23	30	12	1530	38	5400
LPBR 20	20	28.24	30	13	2080	52	7350
LPBR 25	25	35.25	40	17	3400	85	12000
LPBR 30	30	40.27	50	20	4800	120	17000
LPBR 40	40	52.32	60	24	7650	193	27000
LPBR 50	50	62.35	70	27	10800	270	38000

LUHR ..

Linear ball bearing units

LUHR (without seals)

-2LS with 2 seals

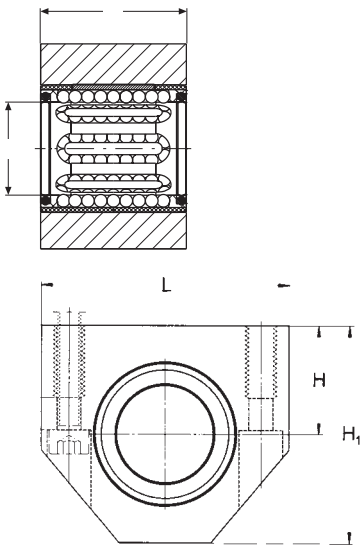

Designations	Dimensions					Basic load ratings	
	F_w	A	H ± 0.01	H_1	L	dynamic C	static C ₀
	mm					N	
LUHR 12	12	28	17	33	40	695	510
LUHR 16	16	30	19	38	45	930	630
LUHR 20	20	30	23	45	53	1160	800
LUHR 25	25	40	27	54	62	2120	1560
LUHR 30	30	50	30	60	67	3150	2700
LUHR 40	40	60	39	76	87	5500	4500
LUHR 50	50	70	47	92	103	6950	6300

Example:
LUHR 16
LUHR 30-2LS

LUHR .. PB

Linear plain bearing units without seals

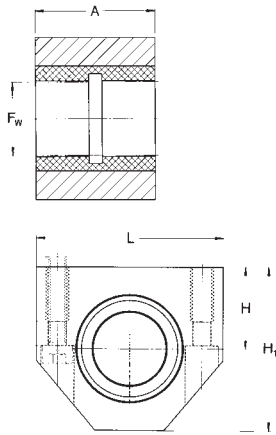

Designations	Dimensions					Basic load ratings		
	F _w	A	H ± 0.01	H ₁	L	dynamic C 0.1 m/s C 4 m/s		static C ₀
	mm					N		
LUHR 12 PB	12	28	17	33	40	965	24	3350
LUHR 16 PB	16	30	19	38	45	1530	38	5400
LUHR 20 PB	20	30	23	45	53	2080	52	7350
LUHR 25 PB	25	40	27	54	62	3400	85	12000
LUHR 30 PB	30	50	30	60	67	4800	120	17000
LUHR 40 PB	40	60	39	76	87	7650	193	27000
LUHR 50 PB	50	70	47	92	103	10800	270	38000

LUJR

Linear ball bearing units with shaft seals

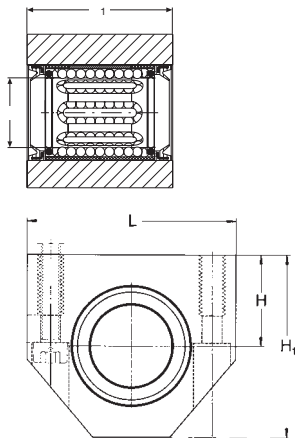

Designations	Dimensions					Basic load ratings	
	F _w	A ₁	H ± 0.01	H ₁	L	dynamic C	static C ₀
	mm					N	
LUJR 12	12	35	17	33	40	695	510
LUJR 16	16	37	19	38	45	930	630
LUJR 20	20	39	23	45	53	1160	800
LUJR 25	25	49	27	54	62	2120	1560
LUJR 30	30	59	30	60	67	3150	2700
LUJR 40	40	71	39	76	87	5500	4500
LUJR 50	50	81	47	92	103	6950	6300

LTBR ..

Tandem linear ball bearing units
LTBR (without seals)
-2LS with two seals

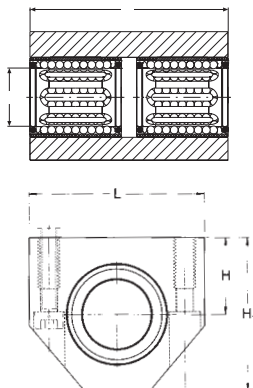

Designations	Dimensions					Basic load ratings	
	F _w	A	H ± 0.01	H ₁	L	dynamic C	static C ₀
	mm					N	
LTBR 12	12	60	17	33	40	1140	1020
LTBR 16	16	65	19	38	45	1530	1270
LTBR 20	20	65	23	45	53	1900	1600
LTBR 25	25	85	27	54	62	3450	3150
LTBR 30	30	105	30	60	67	5200	5400
LTBR 40	40	125	39	76	87	9000	9000
LTBR 50	50	145	47	92	103	11400	12700

Example:
LTBR 16
LTBR 30-2LS

2 Guiding systems

Shaft guidings - compact series

LSHS

Shaft block for compact series

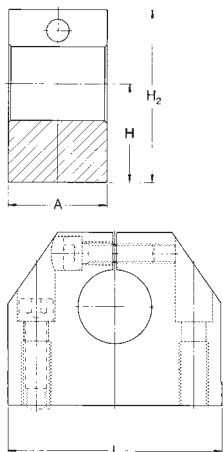

Designations	Dimensions				
	F _w	A	H	H ₂	L
	± 0.01				
	mm				
LSHS 12	12	18	19	33	40
LSHS 16	16	20	22	38	45
LSHS 20	20	24	25	45	53
LSHS 25	25	28	31	54	62
LSHS 30	30	30	34	60	67
LSHS 40	40	40	42	76	87
LSHS 50	50	50	50	92	103

LTDR ..

Duo linear ball bearing units
LTDR (without seals)
-2LS with four seals

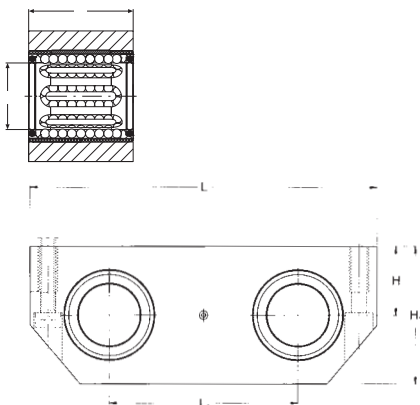

Designations	Dimensions						Basic load ratings	
	F _w	A	H	H ₁	L	L ₁	dynamic C	static C ₀
	± 0.01							
	mm						N	
LTDR 12	12	28	15	30	80	40	1140	1020
LTDR 16	16	30	17.5	35	96	52	1530	1270
LTDR 20	20	30	20	40	115	63	1900	1600
LTDR 25	25	40	25	50	136	75	3450	3150
LTDR 30	30	50	28	56	146	80	5200	5400
LTDR 40	40	60	35	70	184	97	9000	9000
LTDR 50	50	70	40	80	210	107	11400	12700

Example:
LTDR 12
LTDR 25-2LS

LQBR ..

Quadro linear ball bearing units
LQBR (without seals)
-2LS with four seals

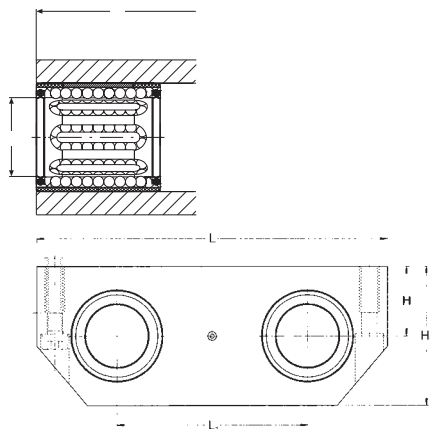

Designations	Dimensions						Basic load ratings	
	F _w	A	H	H ₁	L	L ₁	dynamic C	static C ₀
	± 0.01							
	mm						N	
LQBR 12	12	70	15	30	80	40	1860	2040
LQBR 16	16	80	17.5	35	96	52	2500	2550
LQBR 20	20	85	20	40	115	63	3100	3200
LQBR 25	25	100	25	50	136	75	5600	6300
LQBR 30	30	130	28	56	146	80	8500	10800
LQBR 40	40	150	35	70	184	97	14600	18000
LQBR 50	50	175	40	80	210	107	18600	25500

Example:
LQBR 40
LQBR 30-2LS

LEBS

Tandem shaft blocks suitable for LQBR and LTDR

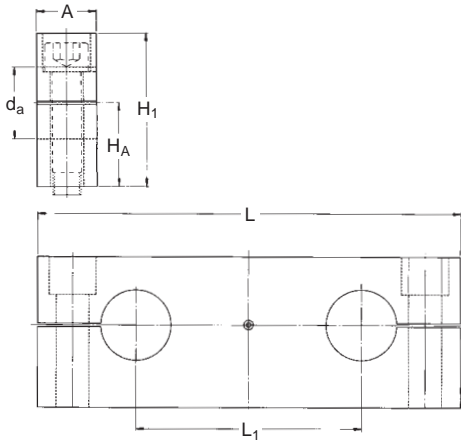

Designations	Dimensions					
	d_a	A	H_A ± 0.01	H_1	L	L_1
	mm					
LEBS 12 A	12	15	17	30	80	40
LEBS 16 A	16	15	19.5	35	96	52
LEBS 20 A	20	18	22	40	115	63
LEBS 25 A	25	20	27	50	136	75
LEBS 30 A	30	20	31	56	146	80
LEBS 40 A	40	25	38	70	184	97
LEBS 50 A	50	30	43	80	210	107

2

Appropriate special seals

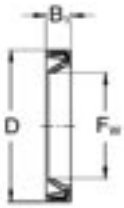

Designations	Dimensions		
	F_w	D	B_1
	mm		
SP - 6×12×2	6	12	2
SP - 8×15×3	8	15	3
SP - 10×17×3	10	17	3
SP - 12×19×3	12	19	3
SP - 14×21×3	14	21	3
SP - 16×24×3	16	24	3
SP - 20×28×4	20	28	4
SP - 25×35×4	25	35	4
SP - 30×40×4	30	40	4
SP - 40×52×5	40	52	5
SP - 50×62×5	50	62	5

2 Guiding systems

Shaft guidings - standard series

Ordering key

Type	L						
Bearings, units, components:							
Linear plain bearing.....	P						
Linear ball bearing.....	B						
Single unit.....	U						
Flanged unit.....	V						
Tandem unit.....	T						
Quadro unit.....	Q						
Shaft block.....	S						
Tandem shaft block.....	E						
Shaft support.....	R						
Design (for seals on side see table at end page):							
For P { Closed design (5 - 80).....	AR						
Open design (5 - 80).....	AT						
Self-aligning, closed design (12 - 50).....	CD						
Self-aligning, open design (12 - 50).....	CF						
For B* { Closed design (5 - 80).....	CR						
Open design (12 - 80).....	CT						
Heavy load, open design (20 - 50).....	HT						
Self-aligning, closed design, relubricatable (12 - 50).....	CD						
Self-aligning, radial adjustable, slotted design, relubricatable (12 - 50).....	CE						
Self-aligning, clearance adjustable, open design, relubricatable (12 - 50).....	CF						
For U { Closed design, (relubricatable) (8 - 80).....	CR						
Clearance adjustable, closed design, relubricatable (8 - 80).....	CS						
Clearance adjustable, open design, relubricatable (12 - 80).....	CT						
Self-aligning, clearance adjustable, closed design, relubricatable (12 - 50).....	ND						
Self-aligning, clearance adjustable, slotted design, relubricatable (12 - 50).....	NE						
Self-aligning, clearance adjustable, open design, relubricatable (12 - 50).....	NF						
Nominal diameter:							
∅ in mm							
New bearing series* (for linear ball bearings only).....							
							A
Option(s):							
Without seals.....							no sign
One side sealed.....							-LS
Both sides sealed.....							-2LS
For B* { Without seals, corrosion resistant (for linear ball bearings only).....							/HV6
One side sealed, corrosion resistant (for linear ball bearings only).....							-LS/HV6
Both sides sealed, corrosion resistant (for linear ball bearings only).....							-2LS/HV6
Other option:							
Only valid for LUCR, LUCT:							
With plain bearing, without seals.....							PA
Only valid for LUCT:							
With heavy-load bearing, without seals.....							BH
With heavy-load bearing, both sides sealed.....							BH-2LS
Only valid for LEAS:							
Tandem shaft block, high shaft position.....							A
Tandem shaft block, low shaft position.....							B

NB:

All LBC.. A and LBH.. A Linear ball bearings available in corrosion resistant!

Example: **L U CT** **30 A BH-2LS**

Continued

Seals on ... side(s)	LPAR	LPAT	LBCD	LBCF	LBCR	LBCT	LBHT	LUCD	LUCE	LUCF	LUCR	LUCS	LUCT	LUND	LUNE	LUNF
No	X	X	X	X	X	X	X	X	X	X	X	X	X	X	X	X
One	-	-	X	X	X	X	X	X	X	X	X	X	X	X	X	X
Both	-	-	X	X	X	X	X	X	X	X	X	X	X	X	X	X
Other options	-	-	-	-	-	-	-	-	-	-	PA	-	BH	-	-	-

or PA

Ordering key (Continued)

Type	L				
Bearings, units, components:					
Linear plain bearing	P				
Linear ball bearing	B				
Single unit	U				
Flanged unit	V				
Tandem unit	T				
Quadro unit	Q				
Shaft block	S				
Tandem shaft block	E				
Shaft support	R				
Design (for seals on side see table at end page):					
For V {	Self-aligning, closed design (12 - 50)	CD			
	Closed design (12 - 80)	CR			
	Self-aligning, closed design, relubricatable (12 - 50)	CD			
For T {	Self-aligning, open design, relubricatable (12 - 50)	CF			
	Closed design, relubricatable (12 - 50)	CR			
	Open design, relubricatable (12 - 50)	CT			
For Q {	Self-aligning, closed design, relubricatable (12 - 50)	CD			
	Self-aligning, open design, relubricatable (12 - 50)	CF			
	Closed design, relubricatable (8 - 50)	CR			
	Open design, relubricatable (12 - 50)	CT			
For S {	(8 - 80)	CS			
	(12 - 50)	NS			
For E {	(8 - 50)	AS			
For R {	Without bore holes (12 - 80)	CB			
	With bore holes (12 - 80)	CC			
Nominal diameter:					
Ø in mm					
Option(s):					
Without seals					no sign
One side sealed					-LS
Both sides sealed					-2LS
Other option:					
Only valid for LUCR, LUCT:					
With plain bearing, without seals					PA
Only valid for LUCT:					
With heavy-load bearing, without seals					BH
With heavy-load bearing, both sides sealed					BH-2LS
Only valid for LEAS:					
Tandem shaft block, high shaft position					A
Tandem shaft block, low shaft position					B

Example: **L Q CR** **16** **-2LS**

Seals on ... side(s)	LVCD	LVCR	LTCD	LTCT	LTCT	LQCD	LQCF	LQCR	LQCT	LSCS	LSNS	LEAS	LRCB	LRCC
No	X	X	X	X	X	X	X	X	X	X	X	X	X	X
One	X	X	X	X	X	X	X	X	X	-	-	-	-	-
Both	X	X	X	X	X	X	X	X	X	-	-	-	-	-
Other options	-	-	-	-	-	-	-	-	-	-	-	B or A	-	-

2 Guiding systems

Shaft guidings - standard series, closed types

LBCD ..

Standard series 3

Linear ball bearings self-aligning, closed type

LBCD .. A (without seals)

-LS with one seal

-2LS with two seals

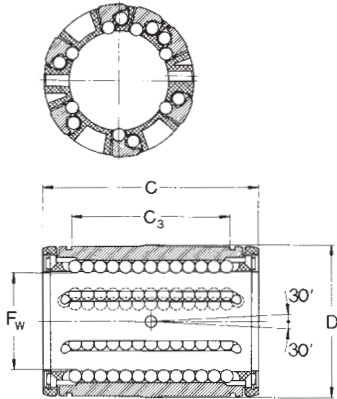

Designations	Dimensions				Basic load ratings	
	F_w	D	C	C_3	dynamic C	static C_0
	mm				N	
LBCD 12 A	12	22	32	20	1080	815
LBCD 16 A	16	26	36	22	1320	865
LBCD 20 A	20	32	45	28	2000	1370
LBCD 25 A	25	40	58	40	2900	2040
LBCD 30 A	30	47	68	48	4650	3250
LBCD 40 A	40	62	80	56	7800	5200
LBCD 50 A	50	75	100	72	11200	6950

Example:
LBCD 25 A
LBCD 16 A-LS
LBCD 40 A-2LS

LBCR ..

Standard series 3

Linear ball bearings, closed type

LBCR .. A (without seals)

-LS with one seal

-2LS with two seals

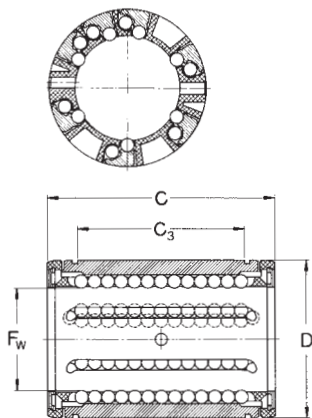

Designations	Dimensions				Basic load ratings	
	F_w	D	C	C_3	dynamic C	static C_0
	mm				N	
LBCR 5 A	5	12	22	12	280	210
LBCR 8 A	8	16	25	14	490	355
LBCR 12 A	12	22	32	20	1160	980
LBCR 16 A	16	26	36	22	1500	1290
LBCR 20 A	20	32	45	28	2240	2040
LBCR 25 A	25	40	58	40	3350	3350
LBCR 30 A	30	47	68	48	5600	5700
LBCR 40 A	40	62	80	56	9000	8150
LBCR 50 A	50	75	100	72	13400	12200
LBCR 60 A	60	90	125	95	20400	18000
LBCR 80 A	80	120	165	125	37500	32000

Example:
LBCR 30 A
LBCR 80 A-LS
LBCR 60 A-2LS

NB:

All LBC .. A and LBH .. A Linear ball bearings available in corrosion resistant!

LPAR

Linear plain bearings without seals, closed type

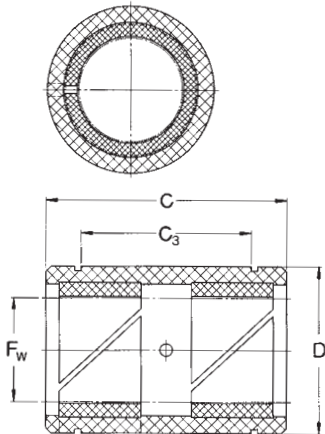

Designations	Dimensions				Basic load ratings		
	F _w	D	C	C ₃	dynamic C 0.1 m/s	C 4 m/s	static C ₀
	mm				N		
LPAR 5	5	12	22	12	280	7	980
LPAR 8	8	16	25	14	510	13	1800
LPAR 12	12	22	32	20	965	24	3350
LPAR 16	16	26	36	22	1530	38	5400
LPAR 20	20	32	45	28	2400	60	8300
LPAR 25	25	40	58	40	4000	100	14000
LPAR 30	30	47	68	48	5500	137	19300
LPAR 40	40	62	80	56	8000	200	28000
LPAR 50	50	75	100	72	12000	300	41500
LPAR 60	60	90	125	95	16600	415	60000
LPAR 80	80	120	165	125	29000	720	100000

LUCD ..

Single units, self-aligning, closed type, relubricatable
LUCD (without seals)
-2LS with two seals

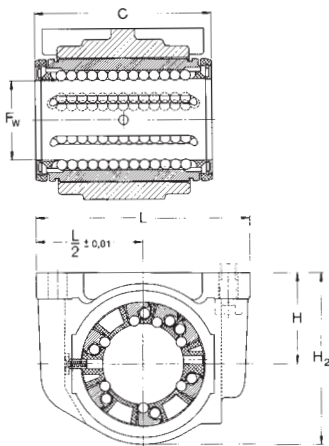

Designations	Dimensions					Basic load ratings	
	F _w	C	H ± 0.01	H ₂	L	dynamic C	static C ₀
	mm					N	
LUCD 12	12	32	18	34.5	52	1080	815
LUCD 16	16	36	22	40.5	56	1320	865
LUCD 20	20	45	25	48	70	2000	1370
LUCD 25	25	58	30	58	80	2900	2040
LUCD 30	30	68	35	67	88	4650	3250
LUCD 40	40	80	45	85	108	7800	5200
LUCD 50	50	100	50	99	135	11200	6950

Example:
LUCD 40
LUCD 12-2LS

2 Guiding systems

Shaft guidings - standard series, closed types

LUCE ..

Single units, self-aligning, clearance adjustable, closed type, relubricatable
LUCE (without seals)

-2LS with two seals

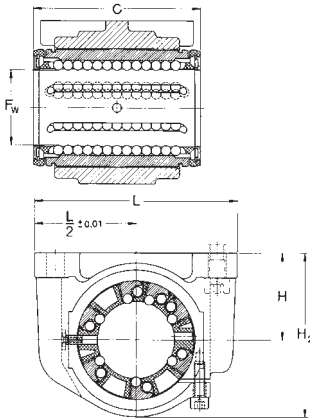

Designations	Dimensions					Basic load ratings	
	F_w	C	H ± 0.01	H_2	L	dynamic C	static C_0
	mm					N	
LUCE 12	12	32	18	34.5	52	1080	815
LUCE 16	16	36	22	40.5	56	1320	865
LUCE 20	20	45	25	48	70	2000	1370
LUCE 25	25	58	30	58	80	2900	2040
LUCE 30	30	68	35	67	88	4650	3250
LUCE 40	40	80	45	85	108	7800	5200
LUCE 50	50	100	50	99	135	11200	6950

Example:
LUCE 25
LUCE 50-2LS

LUCR ..

Single units, closed type, relubricatable
LUCR (without seals)

-2LS with two seals

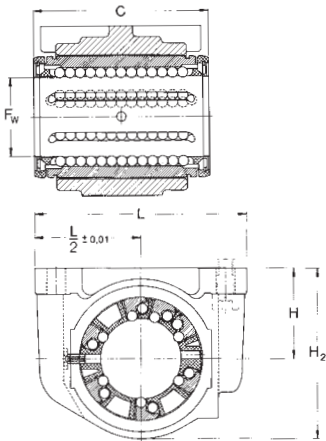

Designations	Dimensions					Basic load ratings	
	F_w	C	H ± 0.01	H_2	L	dynamic C	static C_0
	mm					N	
LUCR 8*	8	25	15	28	45	365	285
LUCR 12	12	32	18	34.5	52	1080	815
LUCR 16	16	36	22	40.5	56	1320	865
LUCR 20	20	45	25	48	70	2000	1370
LUCR 25	25	58	30	58	80	2900	2040
LUCR 30	30	68	35	67	88	4650	3250
LUCR 40	40	80	45	85	108	7800	5200
LUCR 50	50	100	50	99	135	11200	6950
LUCR 60	60	125	60	118	160	20400	18000
LUCR 80	80	165	80	158	205	37500	32000

Example:
LUCR 80
LUCR 8-2LS

* Linear ball bearings fitted to these units are secured with snap rings according to DIN 471 and cannot be relubricated.

LUCR .. PA

Single plain bearing units without seals, closed type

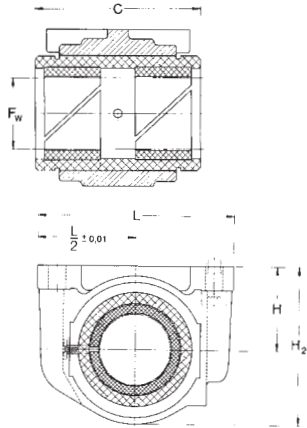

Designations	Dimensions					Basic load ratings dynamic		static C ₀
	F _w	C	H	H ₂	L	C 0.1 m/s	C 4 m/s	
	mm					N		
LUCR 8 PA	8	25	15	28	45	510	13	1800
LUCR 12 PA	12	32	18	34.5	52	965	24	3350
LUCR 16 PA	16	36	22	40.5	56	1530	38	5400
LUCR 20 PA	20	45	25	48	70	2400	60	8300
LUCR 25 PA	25	58	30	58	80	4000	100	14000
LUCR 30 PA	30	68	35	67	88	5500	137	19300
LUCR 40 PA	40	80	45	85	108	8000	200	28000
LUCR 50 PA	50	100	50	99	135	12000	300	41500
LUCR 60 PA	60	125	60	118	160	16600	415	60000
LUCR 80 PA	80	165	80	158	205	29000	720	100000

Delivery time on request

LUCS ..

Single units, clearance adjustable, closed type, relubricatable
LUCS (without seals)
-2LS with two seals

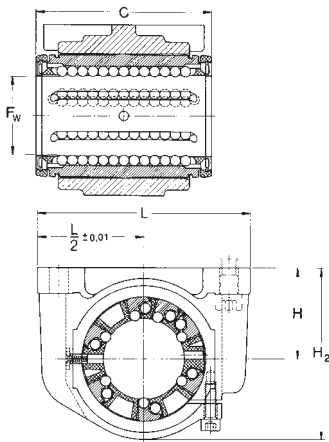

Designations	Dimensions					Basic load ratings dynamic		static C ₀
	F _w	C	H	H ₂	L	C	C ₀	
	mm					N		
LUCS 8*	8	25	15	28	45	365	285	
LUCS 12	12	32	18	34.5	52	1080	815	
LUCS 16	16	36	22	40.5	56	1320	865	
LUCS 20	20	45	25	48	70	2000	1370	
LUCS 25	25	58	30	58	80	2900	2040	
LUCS 30	30	68	35	67	88	4650	3250	
LUCS 40	40	80	45	85	108	7800	5200	
LUCS 50	50	100	50	99	135	11200	6950	
LUCS 60	60	125	60	118	160	20400	18000	
LUCS 80	80	165	80	158	205	37500	32000	

Example:
LUCS 50
LUCS 60-2LS

* Linear ball bearings fitted to these units are secured with snap rings according to DIN 471 and cannot be relubricated.

2 Guiding systems

Shaft guidings - standard series, closed types

LUND ..

Single units, self-aligning, closed type, relubricatable

LUND (without seals)

-2LS with two seals

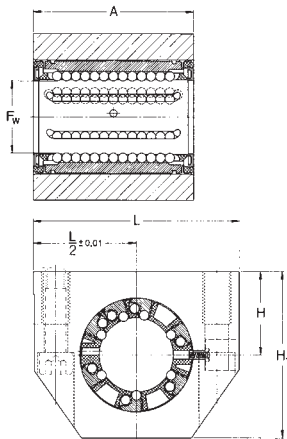

Designations	Dimensions					Basic load ratings	
	F_w	A	H ± 0.01	H_1	L	dynamic C	static C_0
	mm					N	
LUND 12	12	32	18	35	43	1080	815
LUND 16	16	37	22	42	53	1320	865
LUND 20	20	45	25	50	60	2000	1370
LUND 25	25	58	30	61	78	2900	2040
LUND 30	30	68	35	70	87	4650	3250
LUND 40	40	80	45	90	108	7800	5200
LUND 50	50	100	50	105	132	11200	6950

Example:
LUND 12
LUND 30-2LS

LUNE ..

Single units, self-aligning, clearance adjustable, closed type, relubricatable

LUNE (without seals)

-2LS with two seals

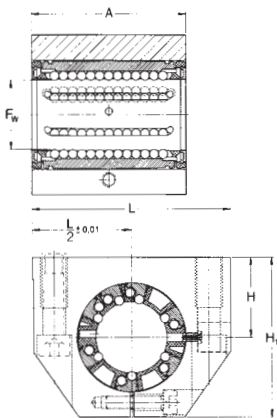

Designations	Dimensions					Basic load ratings	
	F_w	A	H ± 0.01	H_1	L	dynamic C	static C_0
	mm					N	
LUNE 12	12	32	18	35	43	1080	815
LUNE 16	16	37	22	42	53	1320	865
LUNE 20	20	45	25	50	60	2000	1370
LUNE 25	25	58	30	61	78	2900	2040
LUNE 30	30	68	35	70	87	4650	3250
LUNE 40	40	80	45	90	108	7800	5200
LUNE 50	50	100	50	105	132	11200	6950

Example:
LUNE 40
LUNE 16-2LS

LVCD ..

Flanged self-aligning units
LVCD (without seals)
-2LS with two seals

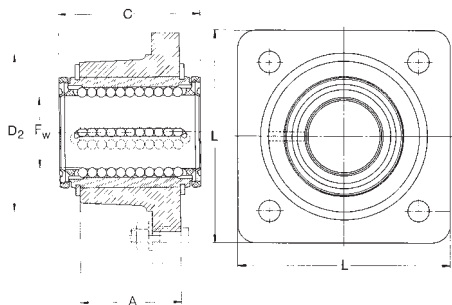

Designations	Dimensions					Basic load ratings	
	F _w	A	C	L	D ₂	dynamic C	static C ₀
	mm					N	
LVCD 12	12	20	32	42	32	1080	815
LVCD 16	16	22	36	50	38	1320	865
LVCD 20	20	28	45	60	46	2000	1370
LVCD 25	25	40	58	74	58	2900	2040
LVCD 30	30	48	68	84	66	4650	3250
LVCD 40	40	56	80	108	90	7800	5200
LVCD 50	50	72	100	130	110	11200	6950

Example:
LVCD 12
LVCD 30-2LS

LVCR ..

Flanged units
LVCR (without seals)
-2LS with two seals

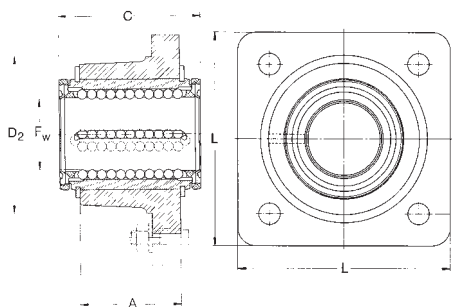

Designations	Dimensions					Basic load ratings	
	F _w	A	C	L	D ₂	dynamic C	static C ₀
	mm					N	
LVCR 12	12	20	32	42	32	1160	980
LVCR 16	16	22	36	50	38	1500	1290
LVCR 20	20	28	45	60	46	2240	2040
LVCR 25	25	40	58	74	58	3350	3350
LVCR 30	30	48	68	84	66	5600	5700
LVCR 40	40	56	80	108	90	9000	8150
LVCR 50	50	72	100	130	110	13400	12200
LVCR 60	60	95	125	160	135	20400	18000
LVCR 80	80	125	165	200	180	37500	32000

Example:
LVCR 20
LVCR 60-2LS

Delivery time on request

2 Guiding systems

Shaft guidings - standard series, closed types

LSCS

Shaft blocks

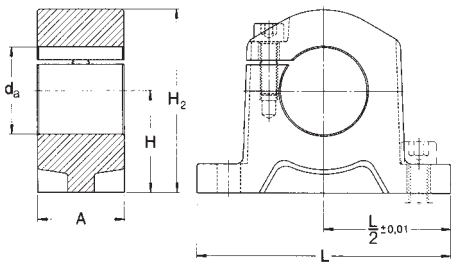

Designations	Dimensions				
	d_a	A	H	H_2	L
	± 0.01				
	mm				
LSCS 8	8	10	15	25	45
LSCS 12	12	12	20	32.5	52
LSCS 16	16	15	20	35.5	56
LSCS 20	20	20	25	43.5	70
LSCS 25	25	28	30	53	80
LSCS 30	30	30	35	63	88
LSCS 40	40	36	45	81	108
LSCS 50	50	49	50	92.5	135
LSCS 60	60	62	60	112	160
LSCS 80	80	85	80	147.5	205

LSNS

Shaft blocks

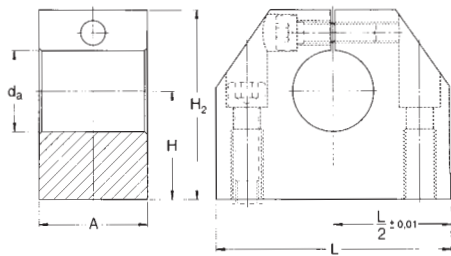

Designations	Dimensions				
	d_a	A	H	H_2	L
	± 0.01				
	mm				
LSNS 12	12	20	20	35	43
LSNS 16	16	24	25	42	53
LSNS 20	20	30	30	50	60
LSNS 25	25	38	35	61	78
LSNS 30	30	40	40	70	87
LSNS 40	40	48	50	90	108
LSNS 50	50	58	60	105	132

LTCD ..

Tandem units, self-aligning, closed type, relubricatable

LTCD (without seals)

-2LS with two seals

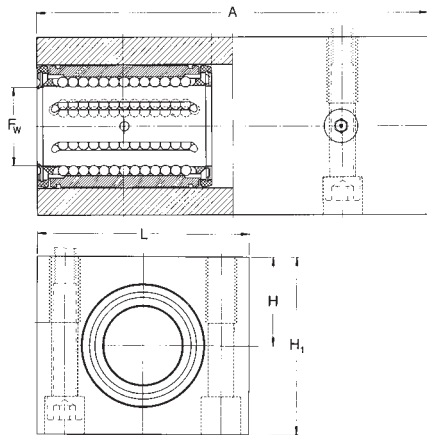

Designations	Dimensions					Basic load ratings	
	F_w	A	H ± 0.01	H_1	L	dynamic C	static C_0
	mm					N	
LTCD 12	12	76	18	35	42	1760	1630
LTCD 16	16	84	22	41.5	50	2160	1730
LTCD 20	20	104	25	49.5	60	3200	2750
LTCD 25	25	130	30	59.5	74	4750	4150
LTCD 30	30	152	35	69.5	84	7500	6550
LTCD 40	40	176	45	89.5	108	12700	10400
LTCD 50	50	224	50	99.5	130	18300	14000

Example:
LTCD 30
LTCD 12-2LS

2

LTCR ..

Tandem units, closed type, relubricatable

LTCR (without seals)

-2LS with two seals

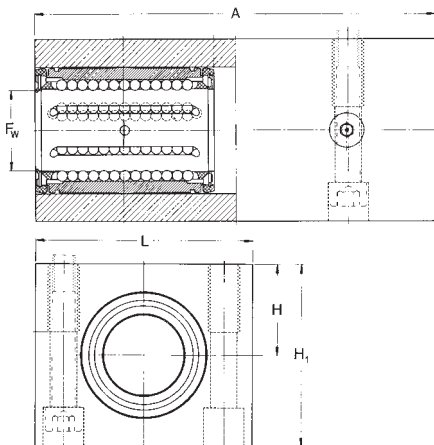

Designations	Dimensions					Basic load ratings	
	F_w	A	H ± 0.01	H_1	L	dynamic C	static C_0
	mm					N	
LTCR 12	12	76	18	35	42	1900	1960
LTCR 16	16	84	22	41.5	50	2450	2600
LTCR 20	20	104	25	49.5	60	3650	4150
LTCR 25	25	130	30	59.5	74	5500	6700
LTCR 30	30	152	35	69.5	84	9150	11400
LTCR 40	40	176	45	89.5	108	15000	16300
LTCR 50	50	224	50	99.5	130	22000	24500

Example:
LTCR 50
LTCR 20-2LS

2 Guiding systems

Shaft guidings - standard series, closed types

LQCD ..

Quadro units, self-aligning, closed type, relubricatable

LQCD (without seals)

-2LS with four seals

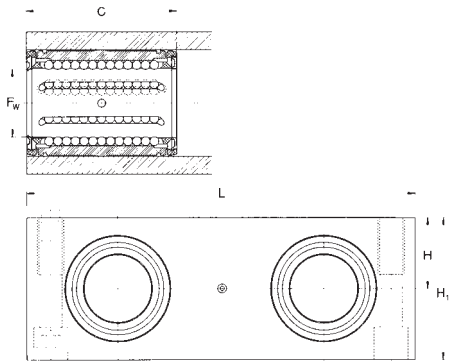

Designations	Dimensions					Basic load ratings	
	F_w	A	H ± 0.01	H_1	L	dynamic C	static C_0
	mm					N	
LQCD 12	12	32	16	32	85	2850	3250
LQCD 16	16	36	18	36	100	3450	3450
LQCD 20	20	45	23	46	130	5200	5500
LQCD 25	25	58	28	56	160	7650	8150
LQCD 30	30	68	32	64	180	12200	12900
LQCD 40	40	80	40	80	230	20800	20800
LQCD 50	50	100	48	96	280	30000	28000

Example:
LQCD 40
LQCD 16-2LS

LQCR ..

Quadro units, closed type, relubricatable

LQCR (without seals)

-2LS with four seals

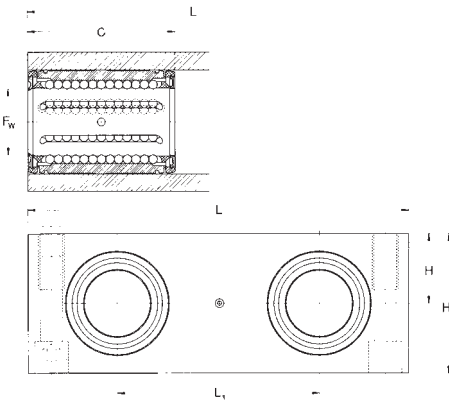

Designations	Dimensions						Basic load ratings	
	F_w	C	H ± 0.01	H_1	L	L_1	dynamic C	static C_0
	mm						N	
LQCR 8	8	25	11.5	23	65	32	965	1140
LQCR 12	12	32	16	32	85	42	3100	4000
LQCR 16	16	36	18	36	100	54	4000	5200
LQCR 20	20	45	23	46	130	72	6000	8300
LQCR 25	25	58	28	56	160	88	9000	13400
LQCR 30	30	68	32	64	180	96	15000	22800
LQCR 40	40	80	40	80	230	122	24000	33500
LQCR 50	50	100	48	96	280	152	35500	49000

Example:
LQCR 25
LQCR 12-2LS

LEAS ..

Tandem shaft blocks, closed type, suitable for LQCD / LQCR

LEAS .. A high shaft position

LEAS .. B low shaft position

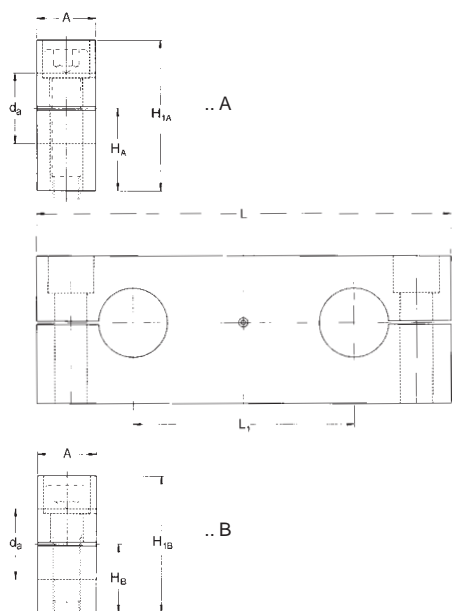

Designations	Dimensions for types A and B				for type A		for type B	
	d_a	A	L	L_1	H_A	H_{1A}	H_B	H_{1B}
mm								
LEAS 8	8	12	65	32	12.5	23	11	22
LEAS 12	12	15	85	42	18	32	14	28
LEAS 16	16	18	100	54	20	37	17	34
LEAS 20	20	20	130	72	25	46	21	42
LEAS 25	25	25	160	88	30	56	26	52
LEAS 30	30	25	180	96	35	64	29	58
LEAS 40	40	30	230	122	44	80	36	72
LEAS 50	50	30	280	152	52	96	44	88

Example:
LEAS 50 A
LEAS 30 B

2 Guiding systems

Shaft guidings - standard series, open types

LBCF ..

Standard series 3

Linear ball bearings, self-aligning, open type

LBCF ..A (without seals)

-LS with one seal

-2LS with two seals

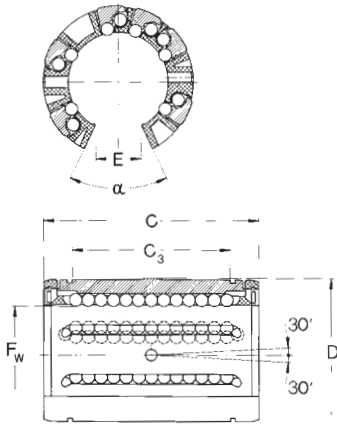

Designations	Dimensions						Basic load ratings		
	F_w	D	C	C_3	E	α	dynamic C	static C_0	
	mm						deg.	N	
LBCF 12 A	12	22	32	20	7.6	78	1080	815	
LBCF 16 A	16	26	36	22	10.4	78	1320	865	
LBCF 20 A	20	32	45	28	10.8	60	2000	1370	
LBCF 25 A	25	40	58	40	13.2	60	2900	2040	
LBCF 30 A	30	47	68	48	14.2	50	4650	3250	
LBCF 40 A	40	62	80	56	18.7	50	7800	5200	
LBCF 50 A	50	75	100	72	23.6	50	11200	6950	

Example:
LBCF 40 A
LBCF 25 A-LS
LBCF 16 A-2LS

LBCT ..

Standard series 3

Linear ball bearings, open type

LBCT .. A (without seals)

-LS with one seal

-2LS with two seals

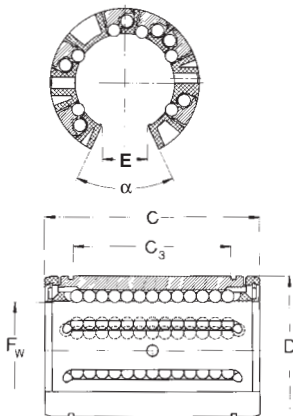

Designations	Dimensions						Basic load ratings		
	F_w	D	C	C_3	E	α	dynamic C	static C_0	
	mm						deg.	N	
LBCT 12 A	12	22	32	20	7.6	78	1160	980	
LBCT 16 A	16	26	36	22	10.4	78	1500	1290	
LBCT 20 A	20	32	45	28	10.8	60	2240	2040	
LBCT 25 A	25	40	58	40	13.2	60	3350	3350	
LBCT 30 A	30	47	68	48	14.2	50	5600	5700	
LBCT 40 A	40	62	80	56	18.7	50	9000	8150	
LBCT 50 A	50	75	100	72	23.6	50	13400	12220	
LBCT 60 A	60	90	125	95	29.6	54	20400	18000	
LBCT 80 A	80	120	165	125	38.4	54	37500	32000	

Example:
LBCT 20 A
LBCT 80 A-LS
LBCT 50 A-2LS

NB:

All LBC .. A and LBH .. A Linear ball bearings available in corrosion resistant!

LBHT ..

Standard series 3

Heavy-load linear ball bearings, open type
LBHT .. A (without seals)

-LS with one seal

-2LS with two seals

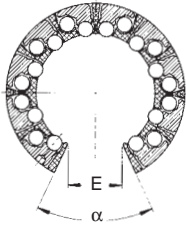

Designations	Dimensions						Basic load ratings		
	F _w	D	C	C ₃	E	α	dynamic C	static C ₀	
	mm						deg.	N	
LBHT 20 A	20	32	45	28	10.8	60	2650	2650	
LBHT 25 A	25	40	58	40	13.2	60	4900	5100	
LBHT 30 A	30	47	68	48	14.2	50	7200	8000	
LBHT 40 A	40	62	80	56	18.7	50	11600	11400	
LBHT 50 A	50	75	100	72	23.6	50	17300	17000	

Example:
LBHT 40 A
LBHT 25 A-LS
LBHT 20 A-2LS

LPAT

Linear plain bearings, without seals, open design

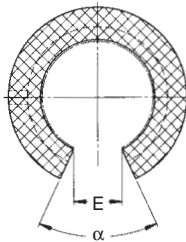

Designations	Dimensions						Basic load ratings			
	F _w	D	C	C ₃	E	α	dynamic C 0.1 m/s	static C 4 m/s	C ₀	
	mm						deg.	N		
LPAT 12	12	22	32	20	7.6	78	965	24	3350	
LPAT 16	16	26	36	22	10.4	78	1530	38	5400	
LPAT 20	20	32	45	28	10.8	60	2400	60	8300	
LPAT 25	25	40	58	40	13.2	60	4000	100	14000	
LPAT 30	30	47	68	48	14.2	50	5500	137	19300	
LPAT 40	40	62	80	56	18.7	50	8000	200	28000	
LPAT 50	50	75	100	72	23.6	50	12000	300	41500	
LPAT 60	60	90	125	95	29.6	54	16600	415	60000	
LPAT 80	80	120	165	125	38.4	54	29000	720	100000	

NB:

All LBC .. A and LBH .. A Linear ball bearings available in corrosion resistant!

2 Guiding systems

Shaft guidings - standard series, open types

LUCF ..

Single units, self-aligning, clearance adjustable, open type, relubricatable
LUCF (without seals)
-2LS with two seals

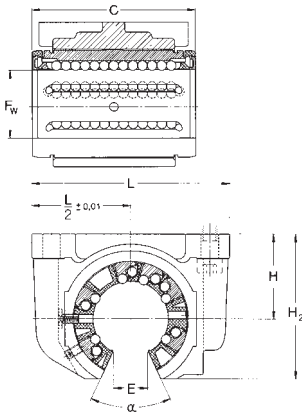

Designations	Dimensions							Basic load ratings		
	F _w	C	H ± 0.01	H ₂	L	E	α	dynamic C	static C ₀	
	mm							deg.	N	
LUCF 12	12	32	18	28	52	7.6	78	1080	815	
LUCF 16	16	36	22	35	56	10.4	78	1320	865	
LUCF 20	20	45	25	42	70	10.8	60	2000	1370	
LUCF 25	25	58	30	51	80	13.2	60	2900	2040	
LUCF 30	30	68	35	60	88	14.2	50	4650	3250	
LUCF 40	40	80	45	77	108	18.7	50	7800	5200	
LUCF 50	50	100	50	88	135	23.6	50	11200	6950	
Example: LUCF 16 LUCF 30-2LS										

LUCT ..

Single units, clearance adjustable, open type, relubricatable
LUCT (without seals)
-2LS with two seals

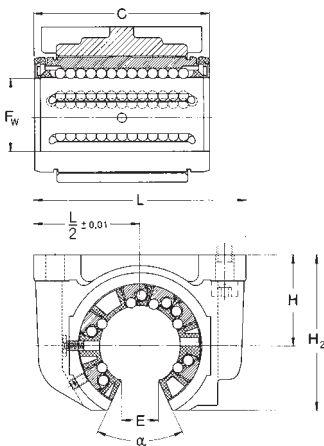

Designations	Dimensions							Basic load ratings		
	F _w	C	H	H ₂	L	E	α	dynamic C	static C ₀	
	mm							deg.	N	
LUCT 12	12	32	18	28	52	7.6	78	1080	815	
LUCT 16	16	36	22	35	56	10.4	78	1320	865	
LUCT 20	20	45	25	42	70	10.8	60	2000	1370	
LUCT 25	25	58	30	51	80	13.2	60	2900	2040	
LUCT 30	30	68	35	60	88	14.2	50	4650	3250	
LUCT 40	40	80	45	77	108	18.7	50	7800	5200	
LUCT 50	50	100	50	88	135	23.6	50	11200	6950	
LUCT 60	60	125	60	105	160	29.6	54	20400	18000	
LUCT 80	80	165	80	140	205	38.4	54	37500	32000	
Example: LUCT 60 LUCT 80-2LS										

LUCT .. BH

Single heavy load units, clearance adjustable, open type, relubricatable
LUCT .. BH (without seals)

-2LS with two seals

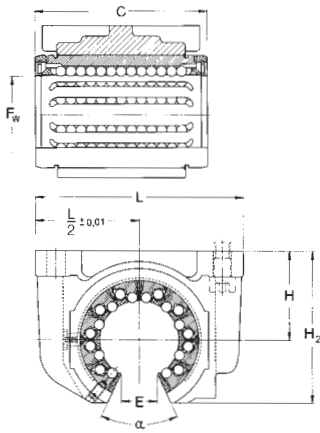

Designations	Dimensions							Basic load ratings		
	F_w	C	H ± 0.01	H_2	L	E	α	dynamic C	static C_0	
	mm							deg.	N	
LUCT 20 BH	20	45	25	42	70	10.8	60	2650	2650	
LUCT 25 BH	25	58	30	51	80	13.2	60	4900	5100	
LUCT 30 BH	30	68	35	60	88	14.2	50	7200	8000	
LUCT 40 BH	40	80	45	77	108	18.7	50	11600	11400	
LUCT 50 BH	50	100	50	88	135	23.6	50	17300	17000	

Example:
LUCT BH 30
LUCT BH 20-2LS

LUCT .. PA

Single units without seals, open type

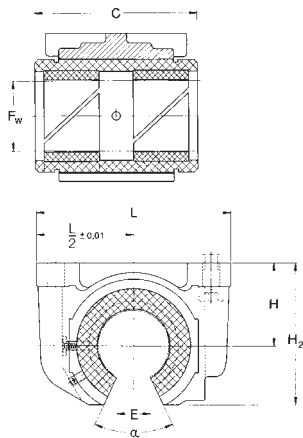

Designations	Dimensions							Basic load ratings			
	F_w	C	H	H_2	L	E	α	dynamic C 0.1 m/s	static C 4 m/s	C_0	
	mm							deg.	N		
LUCT 12 PA	12	32	18	28	52	7.6	78	965	24	3350	
LUCT 16 PA	16	36	22	35	56	10.4	78	1530	38	5400	
LUCT 20 PA	20	45	25	42	70	10.8	60	2400	60	8300	
LUCT 25 PA	25	58	30	51	80	13.2	60	4000	100	14000	
LUCT 30 PA	30	68	35	60	88	14.2	50	5500	137	19300	
LUCT 40 PA	40	80	45	77	108	18.7	50	8000	200	28000	
LUCT 50 PA	50	100	50	88	135	23.6	50	12000	300	41500	
LUCT 60 PA	60	125	60	105	160	29.6	54	16600	415	60000	
LUCT 80 PA	80	165	80	140	205	38.4	54	29000	720	100000	

2 Guiding systems

Shaft guidings - standard series, open types

LUNF ..

Single units, self-aligning, clearance adjustable, open type, relubricatable
LUNF (without seals)

-2LS with two seals

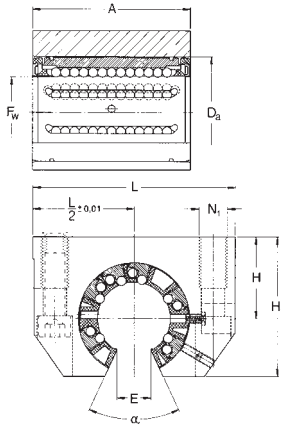

Designations	Dimensions							Basic load ratings		
	F_w	C	H ± 0.01	H_1	L	E	α	dynamic C	static C_0	
	mm							deg.	N	
LUNF 12	12	32	18	28	43	7.6	78	1160	980	
LUNF 16	16	37	22	35	53	10.4	78	1500	1290	
LUNF 20	20	45	25	42	60	10.8	60	2240	2040	
LUNF 25	25	58	30	51	78	13.2	60	3350	3350	
LUNF 30	30	68	35	60	87	14.2	50	5600	5700	
LUNF 40	40	80	45	77	108	18.7	50	9000	8150	
LUNF 50	50	100	50	88	132	23.6	50	13400	12200	

Example:
LUNF 20
LUNF 16-2LS

LTCF ..

Tandem units, self-aligning, open type, relubricatable

LTCF (without seals)

-2LS with two seals

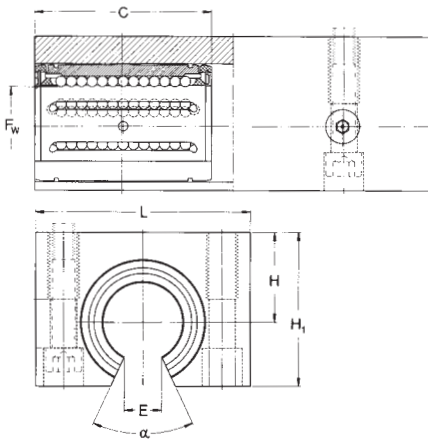

Designations	Dimensions							Basic load ratings		
	F_w	C	H ± 0.01	H_1	L	E	α	dynamic C	static C_0	
	mm							deg.	N	
LTCF 12	12	76	18	29	42	7.6	78	1760	1630	
LTCF 16	16	84	22	35	50	10.4	78	2160	1730	
LTCF 20	20	104	25	42	60	10.8	60	3200	2750	
LTCF 25	25	130	30	51	74	13.2	60	4750	4150	
LTCF 30	30	152	35	60	84	14.2	50	7500	6550	
LTCF 40	40	176	45	77	108	18.7	50	12700	10400	
LTCF 50	50	224	50	88	130	23.6	50	18300	14000	

Example:
LTCF 50
LTCF 12-2LS

LTCT ..

Tandem units, open type, relubricatable
LTCT (without seals)
-2LS with two seals

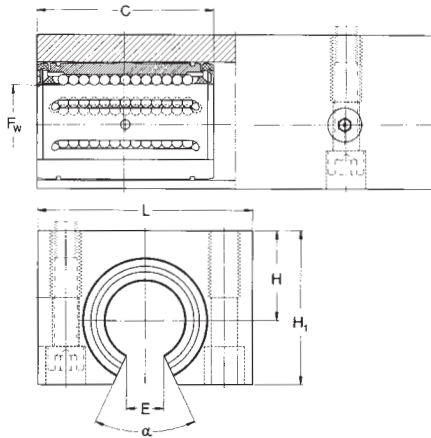

Designations	Dimensions							Basic load ratings		
	F_w	A	H	H_1	L	E	α	dynamic C	static C_0	
	mm							deg.	N	
LTCT 12	12	76	18	29	42	7.6	78	1900	1960	
LTCT 16	16	84	22	35	50	10.4	78	2450	2600	
LTCT 20	20	104	25	42	60	10.8	60	3650	4150	
LTCT 25	25	130	30	51	74	13.2	60	5500	6700	
LTCT 30	30	152	35	60	84	14.2	50	9150	11400	
LTCT 40	40	176	45	77	108	18.7	50	15000	16300	
LTCT 50	50	224	50	88	130	23.6	50	22000	24500	

Example:
LTCT 16
LTCT 30-2LS

LQCF ..

Quadro units, self-aligning, open type,
relubricatable
LQCF (without seals)
-2LS with four seals

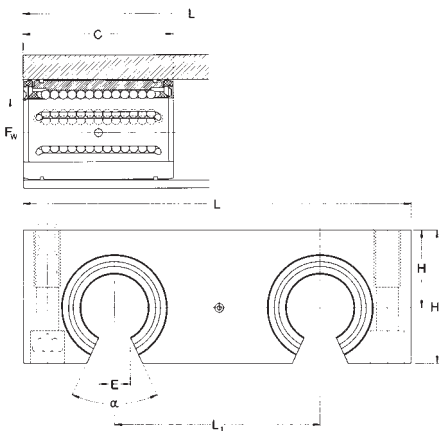

Designations	Dimensions							Basic load ratings		
	F_w	C	H ± 0.01	H_1	L	L_1	E	α	dynamic C	static C_0
	mm							deg.	N	
LQCF 12	12	32	18	30	85	42	7.6	78	2850	3250
LQCF 16	16	36	22	35	100	54	10.4	78	3450	3450
LQCF 20	20	45	25	42	130	72	10.8	60	5200	5500
LQCF 25	25	58	30	51	160	88	13.2	60	7650	8150
LQCF 30	30	68	35	60	180	96	14.2	50	12200	12900
LQCF 40	40	80	45	77	230	122	18.7	50	20800	20800
LQCF 50	50	100	55	93	280	152	23.6	50	30000	28000

Example:
LQCF 12
LQCF 40-2LS

2 Guiding systems

Shaft guidings - standard series, open types

LQCT ..

Quadro units, open type, relubricatable
LQCT (without seals)
-2LS with four seals

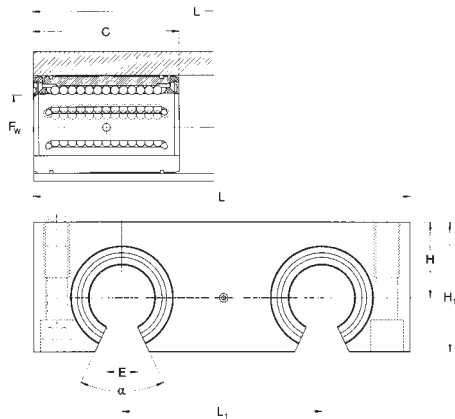

Designations	Dimensions								Basic load ratings		
	F _w	C	H ±0.01	H ₁	L	L ₁	E	α	dynamic C	static C ₀	
	mm								deg.	N	
LQCT 12	12	32	18	30	85	42	7.6	78	3100	4000	
LQCT 16	16	36	22	35	100	54	10.4	78	4000	5200	
LQCT 20	20	45	25	42	130	72	10.8	60	6000	8300	
LQCT 25	25	58	30	51	160	88	13.2	60	9000	13400	
LQCT 30	30	68	35	60	180	96	14.2	50	15000	22800	
LQCT 40	40	80	45	77	230	122	18.7	50	24000	33500	
LQCT 50	50	100	55	93	280	152	23.6	50	35500	49000	

Example:
LQCT 42
LQCT 16-2LS

LRCB/LRCC

Shaft supports
LRCB with bore holes
LRCC without bore holes

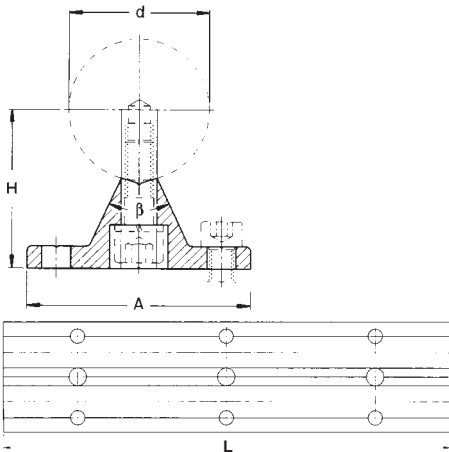

Designations		Dimensions			
		d	A	H ±0.02	L
		mm			
LRCB 12	LRCC 12	12	40	22	600
LRCB 16	LRCC 16	16	45	26	600
LRCB 20	LRCC 20	20	52	32	600
LRCB 25	LRCC 25	25	57	36	600
LRCB 30	LRCC 30	30	69	42	600
LRCB 40	LRCC 40	40	73	50	600
LRCB 50	LRCC 50	50	84	60	600
LRCB 60	LRCC 60	60	94	68	600
LRCB 80	LRCC 80	80	116	86	600

Example:
LRCB 80
LRCC 80



Precision shafts

SKF precision shafts (→ **figure 20**) can be supplied either as solid or hollow shafts. The solid shafts are available in all dimensions required to fit SKF linear ball bearings; the hollow shafts have a minimum outside diameter of 16 mm.

They are induction hardened and ground (**see table on next page**). SKF shafts have exceptionally high dimensional stability and long service life.

Yet at the end of shafts of normal production length, deviations of hardness and dimensional stability can occur.

For special applications, solid shafts of stainless steel or hard chromium plated shafts having a chromium layer approximately 10 µm thick can be supplied. When using stainless steel shafts, it must be taken into account that the surface is not as hard as that of shafts made of high-grade steel. The case depth may also be greater than indicated in **Table 5** and this may have an influence on the machinability of the shafts.

Because of the benefits they offer, SKF precision shafts are not only used in combination with SKF linear ball bearings for linear guides, but also for other purposes, for instance axles or column sleeves.

Tolerances

SKF precision steel shafts are available as standard with a diameter machined to tolerance h6 or h7. Other tolerances on request. Shafts cut to special lengths have a length tolerance to DIN 7168 "medium". The relevant values are given in **Table 4**.

Shafts with radial holes

For linear guides requiring support, shafts with threaded radial holes are needed. These can be supplied by SKF. The radial holes can be positioned either in a way that they accommodate SKF shaft supports or as specified in the customer drawing.

Composite shafts

Composite shafts can be supplied to customer drawings, either with screwed joints or with "plug and socket" joints, depending on the application.

Accurately centred trunnions and sockets guarantee smooth transitions at the butt joint. To ensure correct assembly, the relative positions of the shaft sections and of the shaft ends are marked. Composite

Figure 20

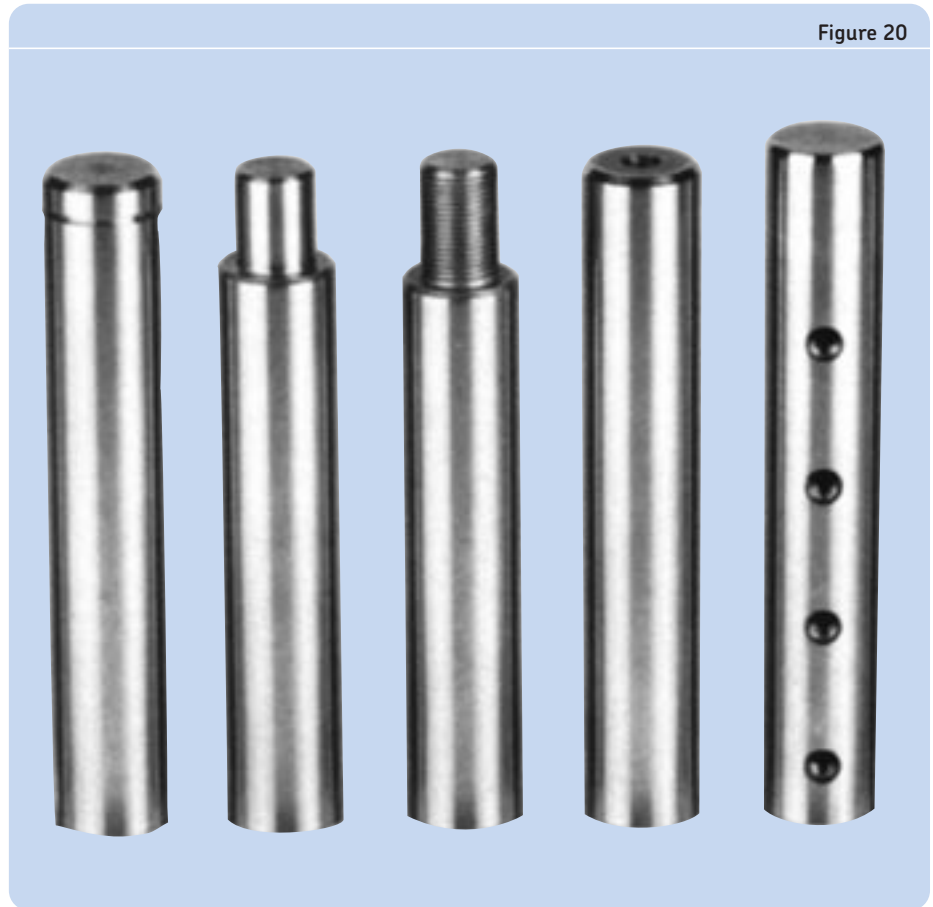

Length tolerances for shafts to DIN 7168, medium series.

Table 4		
Nominal length		Deviation
over	incl.	
mm		
-	120	± 0.3
120	400	± 0.5
400	1000	± 0.8
1000	2000	± 1.2
2000	4000	± 2
4000	8000	± 3

Case depth of SKF shafts.

Table 5		
Shaft diameter		Case depth min
over	incl.	
mm		
-	10	0.5
10	18	0.8
18	30	1.2
30	50	1.5
50	80	2.2
80	100	3.0

shafts should be fastened to a support at the butt joints, particularly when these are of the “plug and socket” type. The radial holes should be positioned as closely to the joint as possible and the shaft length selected in a way that bending of the shaft will not result in a gap forming at the joint.

Materials

SKF precision steel shafts are available as shown in **Tables 6** and **7**.

SKF precision shafts are made from the non-alloyed high-grade steels Cf53 (Material No.1.1213), Ck53 (Material No.1.1210), Ck60 (Material No.1.1221) and 100Cr6 (Material No.12067).

The surface hardness is between approximately 60 and 64 HRC. The solid shafts of stainless steel are made from the steel X90CrMoV18 (Material No.1.4112) or X46Cr13 (Material No.1.4034). In this case the surface hardness lies between approximately 52 and 56 HRC.

Shafts made from other materials can be supplied to special order.

Table 6

Designation	Type
LJM	Precision shaft, steel Ck53/Cf53, 60-64HRC, h6
LJMH	Hard chromium plated precision shaft, steel Ck53/Cf53, min. 60HRC, h7
LJMR	Precision shaft, corrosion resistant, X90CrMoV18, 52-56HRC, h6
LJMS	Precision shaft, corrosion resistant, X46Cr13, 52-56HRC, h6
LJT	Hollow shaft, high-grade steel, Ck60 or 100Cr6, 60-66HRC, h6

Shaft diameter	Standard length*			
	LJM	LJMH	LJMR LJMS	LJT
mm	mm			
3/4**	100 200 300 400 500			
5	2800 - 4100			
6	2800 - 4100			
8	3500 - 4100	3500 - 4100	3500 - 4100	
10	3500 - 4100	3500 - 4100	3500 - 4100	
12	5100 - 6200	5100 - 6200	3500 - 4100	
14	5100 - 6200	5100 - 6200		
16	5100 - 6200	5100 - 6200	3500 - 4100	5100 - 6200
20	5100 - 6200	5100 - 6200	3500 - 4100	5100 - 6200
25	5100 - 6200	5100 - 6200	3500 - 4100	5100 - 6200
30	5100 - 6200	5100 - 6200	3500 - 4100	5100 - 6200
40	5100 - 6200	5100 - 6200	3500 - 4100	5100 - 6200
50	5100 - 6200	5100 - 6200	on request	5100 - 6200
60	5100 - 6200	5100 - 6200	on request	5100 - 6200
80	5100 - 6200	5100 - 6200	on request	5100 - 6200

* Different diameters and lengths on request

** Only available as ESSC 2

Standard shaft lengths

2 Guiding systems

Precision shafts

Ordering key

	LJ					/	
Type							
Designation type:							
Precision shaft, steel Ck53/Cf53, 60-64HRC, h6							M
Hard chromium plated precision shaft, steel Ck53/Cf53, min. 60HRC, h7							MH
Precision shaft, corrosion resistant X90CrMoV18, 52-56HRC, h6							MR
Precision shaft, corrosion resistant, X46Cr13, 52-56HRC, h6							MS
Hollow shaft, high-grade steel, Ck60 or 100Cr6, 60-66HRC, h6							T
Nominal diameter Ø [mm]:							
See Table 7, page 47							
Length [mm]:							
See Table 7, page 47							
End finishing:							
ESSC (1-10), see pages 49-51							
For ESSC 4 - 5: Front side axial thread × depth							
For ESSC 6 - 9: Distance between end face and first radial thread							
For ESSC 5: Front side axial thread × depth							
For ESSC 6 - 9: Distance between the radial threads							

- Example 1: LJ MR 40 1200 ESSC 1
- Example 2: LJ MR 40 1200 ESSC 2
- Example 3: LJ MR 40 1200 ESSC 3
- Example 4: LJ MR 40 1200 ESSC 4 M14×40
- Example 5: LJ MR 40 1200 ESSC 5 M14×40 / M16×50
- Example 6: LJ MR 40 1200 ESSC 6
- Example 7: LJ MR 40 1200 ESSC 7 125 / 250
- Example 8: LJ MR 40 1200 ESSC 8
- Example 9: LJ MR 40 1200 ESSC 9 125 / 250
- Example 10: LJ MR 40 1200 ESSC 10

ESSC 1

Cut, without chamfer, only deburred Length tolerance according to DIN 7168 medium range

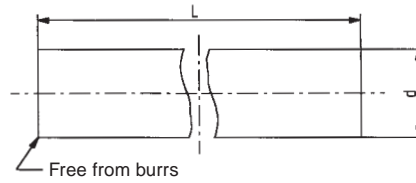

ESSC 2

Cut, with chamfer Length tolerance as ESSC 1

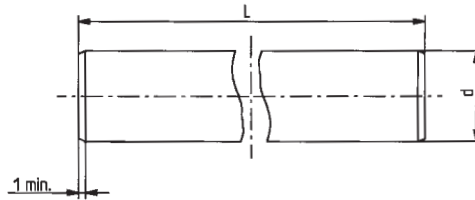

ESSC 3

Cut, 25° machined chamfer, end faces cut at right angles for limited length tolerance or chamfered according to customer specification Length tolerance +/- 0.1 mm to a total length of 3000 mm

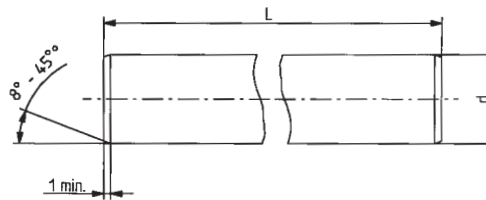

ESSC 4

Cut, 25° machined chamfer, end faces cut at right angles, one front-side (axial) hole Length tolerance as ESSC 3 (→ Table 8)

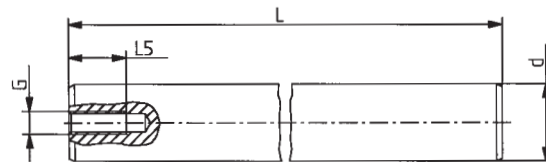

Table 8

Diameter Ø	Thread G	Depth L ₅
mm		
5		
8	M4	10
10	M4	10
12	M5	12.5
14	M5	12.5
16	M6	15
20	M8	20
25	M10	25
30	M10	25
40	M12	30
50	M16	40
60	M20	50
80	M24	60

2 Guiding systems

Precision shafts

ESSC 5

As ESSC 4 with two front side (axial) holes
(→ Table 9)

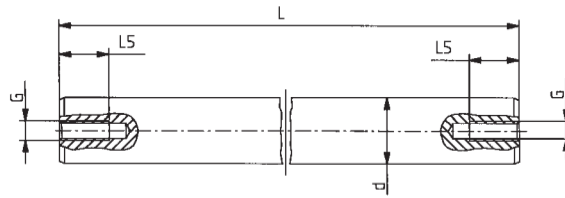

Table 9

Diameter Ø	Thread G	Depth L ₅
mm		
5		
8	M4	10
10	M4	10
12	M5	12.5
14	M5	12.5
16	M6	15
20	M8	20
25	M10	25
30	M10	25
40	M12	30
50	M16	40
60	M20	50
80	M24	60

ESSC 6

Cut and chamfered as ESSC 2
 • with radial holes for LRCB
 • first radial hole at $J_x = J/2$
 • H_1 according to hardening depth
 (→ Table 10)

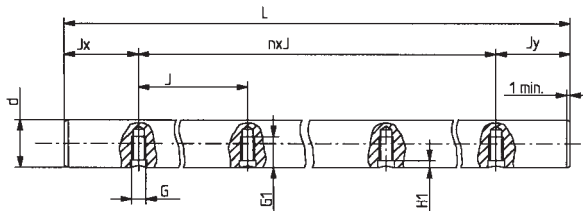

Table 10

Ø	Thread	G	G ₁	J	J _x
mm		mm			
5	-	-	-	-	-
8	-	-	-	-	-
12	M4	5	8	75	37.5
16	M5	6	9.5	100	50
20	M6	7	13	100	50
25	M8	9	14	120	60
30	M10	11	18	150	75
40	M10	11	20	200	100
50	M12	13	23	200	100
60	M14	15	28	300	150
80	M16	16	33	300	150

ESSC 7

As ESSC 6
 • radial holes with J and J_x
 according to customer specification
 (→ Table 11)

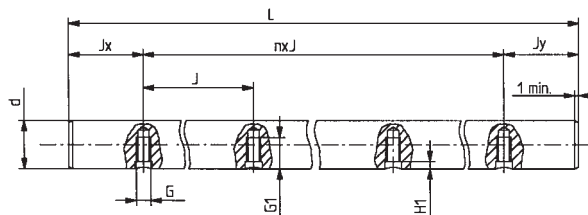

Table 11

Ø	Thread	G	G ₁	J	J _x
mm		mm			
5	-	-	-	-	-
8	-	-	-	-	-
12	M4	5	8	-	-
16	M5	6	9.5	-	-
20	M6	7	13	-	-
25	M8	9	14	-	-
30	M10	11	18	-	-
40	M10	11	20	-	-
50	M12	13	23	-	-
60	M14	15	28	-	-
80	M16	16	33	-	-

ESSC 8

Cut and chamfer as ESSC 2

- shaft mounted on LRCB
- first radial hole with $J_x = J/2$
- H_1 according to hardness depth
(→ Table 12)

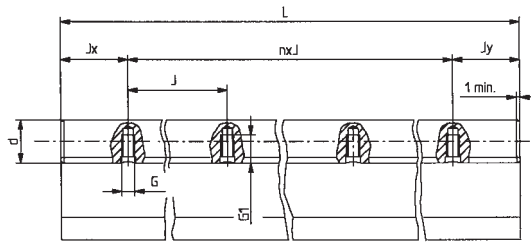

Table 12

Ø	Thread	G	G ₁	J	J _x
mm		mm			
5	-	-	-	-	-
8	-	-	-	-	-
12	M4	5	8	75	37.5
16	M5	6	9.5	100	50
20	M6	7	13	100	50
25	M8	9	14	120	60
30	M10	11	18	150	75
40	M10	11	20	200	100
50	M12	13	23	200	100
60	M14	15	28	300	150
80	M16	16	33	300	150

ESSC 9

As ESSC 8

- shaft mounted on LRCC
- radial holes with J and J_x according to customer specification
(→ Table 13)

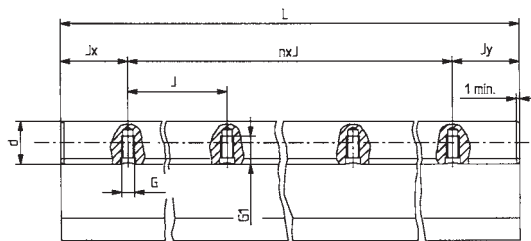

Table 13

Ø	Thread	G	G ₁	J	J _x
mm		mm			
5	-	-	-	-	-
8	-	-	-	-	-
12	M4	5	8	-	-
16	M5	6	9.5	-	-
20	M6	7	13	-	-
25	M8	9	14	-	-
30	M10	11	18	-	-
40	M10	11	20	-	-
50	M12	13	23	-	-
60	M14	15	28	-	-
80	M16	16	33	-	-

ESSC 10

Shaft according to customer specification

- manufacture only according to customer drawing

2 Guiding systems

Precision shafts

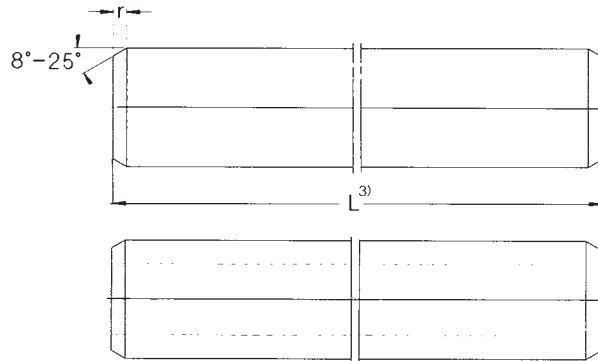
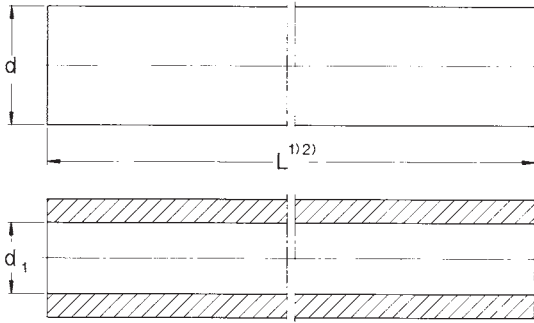

Standard designs

Designs for fixed length without chamfer

Designs for fixed length with chamfer

Table 14 shows basic data for the various models for the precision shafts.

Table 14

Dimension	Mass		Moment of inertia		Cross sectional area		Designations						
	Solid shaft	Hollow shaft	Solid shaft	Hollow shaft	Solid shaft	Hollow shaft	Solid shaft of precision steel Ck53 (1.1210) Cf53 (1.1213)	Solid shaft of stainless steel X90CrMoV18 (1.4112) X46Cr13 (1.4034)	Solid shaft with high grade steel chromium Ck53 (1.1210) Cf53 (1.1213)	Hollow shaft high grade steel C60 (1.1221) plated			
d	d ₁	r _{min}											
mm		kg/m	cm ⁴		mm ²								
3	-	0.4	0.06	-	0.0004	-	7.1	-	LJM 3				
4	-	0.4	0.1	-	0.0013	-	12.6	-	LJM 4				
5	-	0.8	0.15	-	0.0031	-	19.6	-	LJM 5				
6	-	0.8	0.22	-	0.0064	-	28.3	-	LJM 6				
8	-	0.8	0.39	-	0.020	-	50.3	-	LJM 8	LJMR 8	LJMS 8	LJMH 8	
10	-	0.8	0.62	-	0.049	-	78.5	-	LJM 10	LJMR 10	LJMS 10	LJMH 10	
12	-	1	0.89	-	0.102	-	113	-	LJM 12	LJMR 12	LJMS 12	LJMH 12	
14	-	1	1.21	-	0.189	-	154	-	LJM 14			LJMH 14	
16	7	1	1.57	1.28	0.322	0.310	201	163	LJM 16	LJMR 16	LJMS 16	LJMH 16	LJT 16
20	12	1.5	2.45	1.26	0.785	0.597	314	160	LJM 20	LJMR 20	LJMS 20	LJMH 20	LJT 20
25	14	1.5	3.83	2.40	1.92	1.64	491	305	LJM 25	LJMR 25	LJMS 25	LJMH 25	LJT 25
30	19	1.5	5.51	3.55	3.98	3.46	707	453	LJM 30	LJMR 30	LJMS 30	LJMH 30	LJT 30
40	26	2	9.80	5.40	12.6	9.96	1260	685	LJM 40	LJMR 40	LJMS 40	LJMH 40	LJT 40
50	35	2	15.3	10.6	30.7	27.7	1960	1350	LJM 50	LJMR 50	LJMS 50	LJMH 50	LJT 50
60	36	2.5	22.1	15.1	63.6	57.1	2830	1920	LJM 60			LJMH 60	LJT 60
80	53	2.5	39.2	20.1	201	153	5030	2565	LJM 80			LJMH 80	LJT 80

Attention:

d₁ can deviate from the value quoted. Please enquire if necessary. Different shaft diameters and types on request.

The static load capacity has to be decreased by 8% and the dynamic load capacity by 18% when using the non-rusting types (HV6) in conjunction with precision steel shafts made of stainless steel.

Shafts cut to special length with flat turned ends. The length tolerance of these shafts corresponds to DIN 7168, medium. The designation for a shaft with 20 mm diameter cut to a length of 1.5 m is, for example, LJM 20×1500.

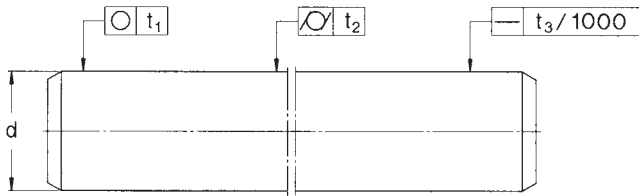

Table 15 shows basic data for the various models for the precision shafts of high-grade steel.

Table 15

Shaft	Accuracy of dimension and form									
	Shafts to tolerance h6					Shafts to tolerance h7				
	Nominal diameter d	Diameter deviation		Circularity	Cylindricity	Straightness ¹⁾	Diameter deviation		Circularity	Cylindricity
high		low	t ₁	t ₂	t ₃	high	low	t ₁	t ₂	t ₃
mm	μm									
3	0	-6	3	4	150	0	-10	4	6	150
4	0	-8	4	5	150	0	-12	5	8	150
5	0	-8	4	5	150	0	-12	5	8	150
6	0	-8	4	5	150	0	-12	5	8	150
8	0	-9	4	6	120	0	-15	6	9	120
10	0	-9	5	7	120	0	-15	7	10	120
12	0	-11	5	8	100	0	-18	8	11	100
14	0	-11	5	8	100	0	-18	8	11	100
16	0	-11	5	8	100	0	-18	8	11	100
20	0	-13	6	9	100	0	-21	9	13	100
25	0	-13	6	9	100	0	-21	9	13	100
30	0	-13	6	9	100	0	-21	9	13	100
40	0	-16	7	11	100	0	-25	11	16	100
50	0	-16	7	11	100	0	-25	11	16	100
60	0	-19	8	13	100	0	-30	13	19	100
80	0	-19	8	13	100	0	-30	13	19	100

¹⁾ Shafts with straightness 50 mm/1000 mm to order

2 Guiding systems

Linear ball bearing table without drive

Linear ball bearing table without drive

LZBU quadro-linear tables (→ figure 21)

The closed LZBU quadro-linear table consists of a closed quadro linear bearing unit, two tandem shaft blocks and two shafts of the required length.

The bearing unit is fitted with four LBCD .. A-LS self-aligning linear ball bearings each sealed on one side. The LZBU .. A design permits axial movement of the linear bearing unit, i.e. the shafts are fixed, to the machine bed via the LEAS .. A shaft blocks. The LZBU .. B design is provided with LEAS .. B shaft blocks. This combination allows the shafts to travel with the shaft blocks in applications where the linear bearing unit is fixed. LZBU quadro-linear tables can be supplied in sizes 8 to 50 mm. Size 8 tables are however not self-aligning and they are not designed for relubrication.

The description of the closed quadro-linear tables also applies to the combination of LQBR .. 2LS quadro-linear bearing units of Series 1 with twin LEBS tandem shaft blocks and shafts with a diameter of 12 to 50 mm.

LZAU quadro-linear tables

The open LZAU quadro-linear comprises the open quadro-linear unit and two high precision shafts with shaft supports. The

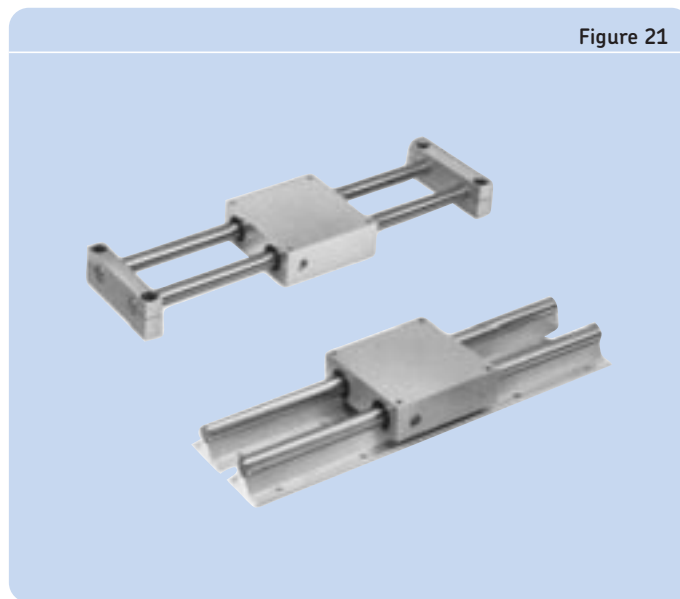

Figure 21

bearing unit is fitted with four LBCF .. A-LS self-aligning linear ball bearings, each sealed at one side. The standard lengths of these tables is dictated by the pitch of the attachment holes in the LRCB shaft supports. The total length should always be a multiple of this distance.

LZAU quadro-linear tables are available in sizes 12 to 50 mm.

Ordering key

LZ -2LS ×

Type

Design:

Open design AU
 Closed design BU

Nominal diameter Ø in mm:

For AU Ø 12 - 50
 For BU Ø 8 - 50

Option:

LZAU with LRCB shaft supports no sign
 LEAS A, high shaft position A
 LEAS B, low shaft position B

Other option:

Both sides sealed -2LS

Length in mm:



Example: LZ BU 40 B -2LS × 1500

2 Guiding systems

Linear ball bearing table without drive

LZBU .. A-2LS

Quadro linear tables, consisting of LQCD, LEAS A and shafts

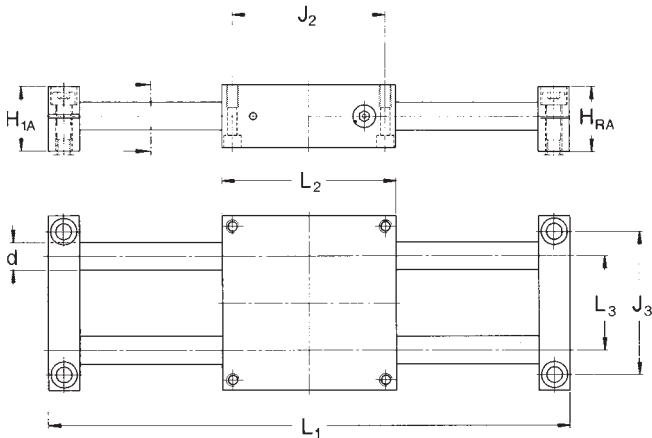

Designations	Dimensions								Basic load ratings	
	d	H _{RA}	H _{1A}	L ₁	L ₂	L ₃	J ₂	J ₃	dynamic C	static C ₀
	mm								N	
LZBU 8 A-2LS	8	24	23	600	65	32	55	52	965	1140
LZBU 12 A-2LS	12	34	32	900	85	42	73	70	2850	3250
LZBU 16 A-2LS	16	38	37	1500	100	54	88	82	3450	3450
LZBU 20 A-2LS	20	48	46	1800	130	72	115	108	5200	5500
LZBU 25 A-2LS	25	58	56	1800	160	88	140	132	7650	8150
LZBU 30 A-2LS	30	67	64	2400	180	96	158	150	12200	12900
LZBU 40 A-2LS	40	84	80	3000	230	122	202	190	20800	20800
LZBU 50 A-2LS	50	100	96	3000	280	152	250	240	30000	28000

Dimensions										
Standard length										
d	L									
mm	Length increments in mm									
8	300	600	900	-	-	-	-	-	-	-
12	300	600	900	1200	1500	1800	2100	2400	2700	3000
16	300	600	900	1200	1500	1800	2100	2400	2700	3000
20	300	600	900	1200	1500	1800	2100	2400	2700	3000
25	300	600	900	1200	1500	1800	2100	2400	2700	3000
30	300	600	900	1200	1500	1800	2100	2400	2700	3000
40	300	600	900	1200	1500	1800	2100	2400	2700	3000
50	-	600	900	1200	1500	1800	2100	2400	2700	3000

LZBU .. B-2LS

Quadro linear tables, consisting of LQCD, LEAS B and shafts

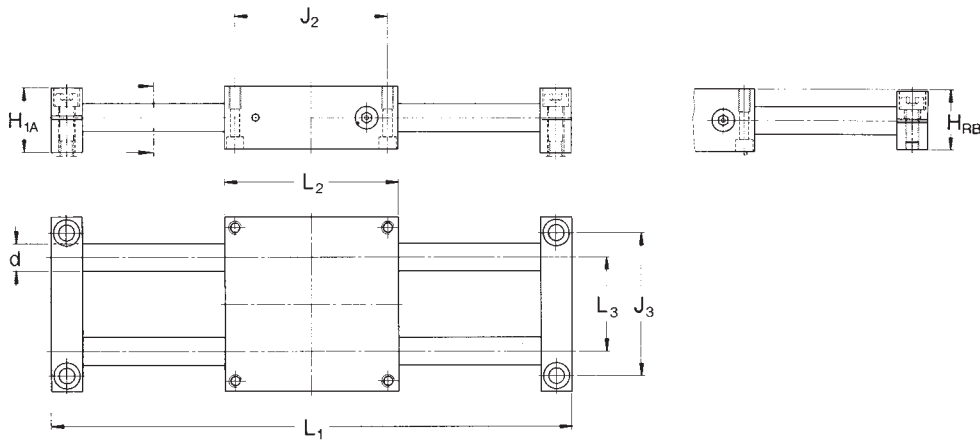

Designations	Dimensions								Basic load ratings	
	d	H _{RB} ± 0.01	H _{1A}	L ₁	L ₂	L ₃	J ₂	J ₃	dynamic C	static C ₀
	mm								N	
LZBU 8 B-2LS	8	22.5	22	600	65	32	55	52	965	1140
LZBU 12 B-2LS	12	30	28	900	85	42	73	70	2850	3250
LZBU 16 B-2LS	16	35	34	1500	100	54	88	82	3450	3450
LZBU 20 B-2LS	20	44	42	1800	130	72	115	108	5200	5200
LZBU 25 B-2LS	25	54	52	1800	160	88	140	132	7650	8150
LZBU 30 B-2LS	30	61	58	2400	180	96	158	150	12200	12900
LZBU 40 B-2LS	40	76	72	3000	230	122	202	190	20800	20800
LZBU 50 B-2LS	50	92	88	3000	280	152	250	240	30000	28000

Dimensions										
Standard length										
d	L									
mm	Length increments in mm									
8	300	600	900	-	-	-	-	-	-	-
12	300	600	900	1200	1500	1800	2100	2400	2700	3000
16	300	600	900	1200	1500	1800	2100	2400	2700	3000
20	300	600	900	1200	1500	1800	2100	2400	2700	3000
25	300	600	900	1200	1500	1800	2100	2400	2700	3000
30	300	600	900	1200	1500	1800	2100	2400	2700	3000
40	300	600	900	1200	1500	1800	2100	2400	2700	3000
50	-	600	900	1200	1500	1800	2100	2400	2700	3000

2 Guiding systems

Linear ball bearing table without drive

LZAU .. -2LS

Quadro linear tables, consisting of LQCF and supported shafts

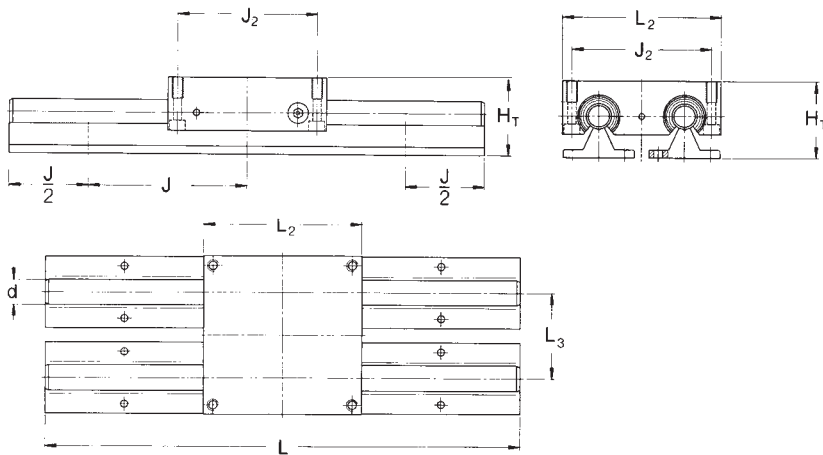

Designations	Dimensions							Basic load ratings	
	d	HT	J	L	L ₂	L ₃	J ₂	dynamic C	static C ₀
	± 0.03		± 0.015						
	mm							N	
LZAU 12-2LS	12	40	75	900	85	42	73	2850	3250
LZAU 16-2LS	16	48	100	1500	100	54	88	3450	3450
LZAU 20-2LS	20	57	100	1800	130	72	115	5200	5500
LZAU 25-2LS	25	66	120	1800	160	88	140	7650	8150
LZAU 30-2LS	30	77	150	2400	180	96	158	12200	12900
LZAU 40-2LS	40	95	200	3000	230	122	202	20800	20800
LZAU 50-2LS	50	115	200	3000	280	152	250	30000	28000

Dimensions										
Standard length										
d	L									
mm	Length increments in mm									
8	300	600	900	-	-	-	-	-	-	-
12	300	600	900	1200	1500	1800	2100	2400	2700	3000
16	300	600	900	1200	1500	1800	2100	2400	2700	3000
20	300	600	900	1200	1500	1800	2100	2400	2700	3000
25	300	600	900	1200	1500	1800	2100	2400	2700	3000
30	300	600	900	1200	1500	1800	2100	2400	2700	3000
40	300	600	900	1200	1500	1800	2100	2400	2700	3000
50	-	600	900	1200	1500	1800	2100	2400	2700	3000



More precision for more performance.

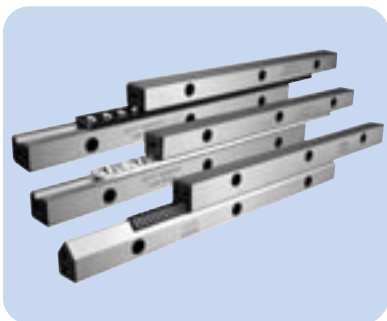

Have you ever wondered how a bird's nest, which appears to be so fragile, can withstand the heaviest rain and strong winds? Birds can weave even the smallest twigs with great precision to form the supporting structure of the nest for the protection of their eggs and new-born chicks from the weather.

This small miracle of nature gives SKF the inspiration to create solutions to satisfy a wide variety of requests for precision with micrometer accuracy. Products like precision rail guides, also available with the state-of-the-art Anti-creep system, and the precision slides are high quality tools for linear motion which are ideally suited for uses in a wide range of applications where close tolerances are demanded.

SKF products are created to build the future.

Linear motion from SKF
www.linearmotion.skf.com



2 Guiding systems

Linear guiding system Speedi-Roll

Linear guiding system Speedi-Roll

To complement its versatile range of linear motion products, SKF has introduced the LLE linear guiding system (→ **figure 22**), a highly efficient unit marketed under the name “Speedi-Roll”. In response to current market demands, this product was developed giving high priority to lightweight construction and ease of installation.

Speedi-Roll is a linear guiding system with high load-carrying capacity, rigidity and torque resistance, consisting of a guide rail and a carriage with either four or six rollers. The rail consists of a drawn and anodised aluminium profile with hardened steel angle raceways fitted to both sides.

The aluminium base plate of the carriage, which is also anodised, houses the factory-fitted rollers. A special feature of this roller design is the presence of elastic elements around the threaded bolt adjusting the rollers and fixing them in the base plate. This unique patented system avoids the risk of mounting errors, thus contributing to a more efficient and cost effective installation.

As standard, the units are supplied with light preload. In order to cover a wide range of applications, SKF offers three sizes: LLE 15, 25 and 35. This allows flexibility when selecting a system to meet the design parameters.

Speedi-Roll guides operate effortlessly and quietly. The high linear speed rating permits shorter cycle times, and the low friction between rail and rollers allows less

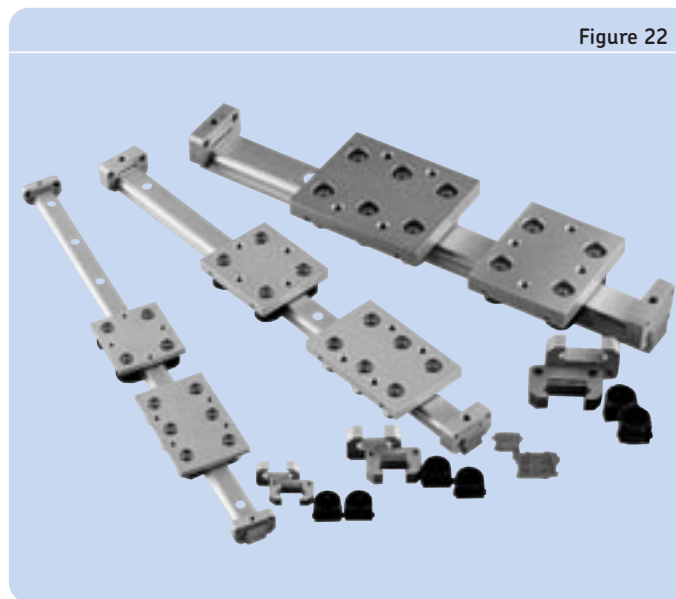

Figure 22

power input for driving the system. The hollow centre of size 25 and 35 rails helps to reduce the mass of the entire system. In addition, these “bores” can serve as wire or cable channels. The rollers are lubricated for life, greatly reducing the need for service.

Roller covers and end stops are available to complete the product range. It is possible to produce customer specific configurations using the standard rollers and steel angle raceways in addition to the catalogue range.

Ordering key

LLE
H

-

/

E=0

Type

Guide rail type:

..... H

System key:

Guide rail and carriage (system)	S
Carriage	C
Guide rail	R
Roller	E
Roller cover	X
End stop	M

Size:

(18 mm)	15
(23 mm)	25
(36 mm)	35

Carriage type:

Standard (4 rollers)	H
Long (6 rollers)	L

Sealing:

Without roller covers	Z
With roller covers	C

Number of carriages per guide rail: 1, 2, ..., n

Length of guide rail [mm]

Special design:

Joint rail	A
Guide rails as specified	D
System with one end stop	M1
System with two end stops	M2
Hard chromium plated	H

Distance between end face and the first hole [mm]:

Symmetric holes as standard E = 0



Example: LLE H S 15 H Z 2 - 300 / M1 E=0

2 Guiding systems

Linear guiding system Speedi-Roll

LLEHR ..

Rails in standard length

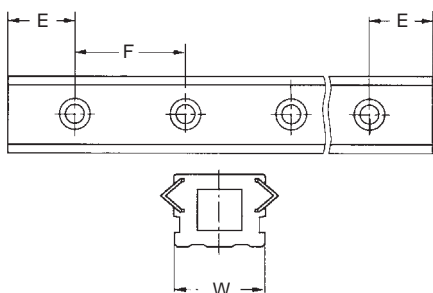

Designations	Dimensions		
	W	F	E
	mm		
LLEHR 15	18	62.5	31.25
LLEHR 25	23	125.0	62.5
LLEHR 35	36	250.0	125.0

LLEHC .. HZ /.. HC

Standard carriages

LLEHC .. HZ without roller covers

LLEHC .. HC with roller covers

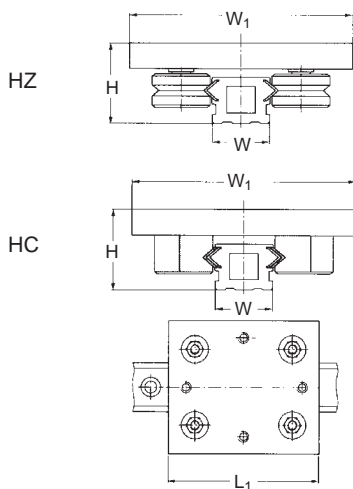

Designations	Dimensions			
	W	W ₁	H	L ₁
	mm			
LLEHR 15 HZ HC	18	65	25.0	70
LLEHR 25 HZ HC	23	80	35.5	90
LLEHR 35 HZ HC	36	120	54.3	100

LLEHC .. LZ / .. LC

Long carriages

LLEHC .. LZ without roller covers

LLEHC .. LC with roller covers

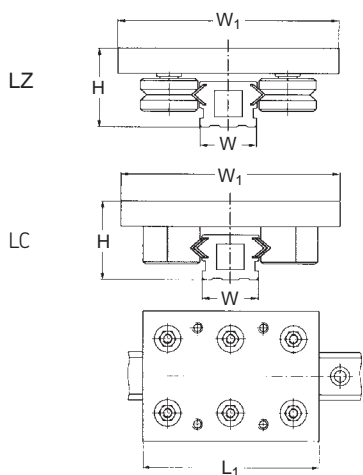

Designations	Dimensions			
	W	W ₁	H	L ₁
	mm			
LLEHC 15 LZ LC	18	65	25.0	105
LLEHC 25 LZ LC	23	80	35.5	120
LLEHC 35 LZ LC	36	120	54.3	140

LLEHM

End stops

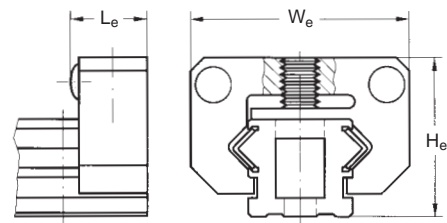

Designations	Dimensions		
	W _e	H _e	L _e
	mm		
LLEHM 15	38	24.5	11.1
LLEHM 25	48	34.1	16.6
LLEHM 35	65	52.0	16.6

LLEHX

Roller covers

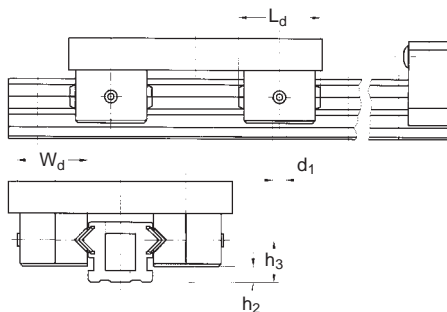

Designations	Dimensions				
	L _d	W _d	h ₂	h ₃	d ₁
	mm				
LLEHX 15	29.2	25.1	1.65	10.75	2
LLEHX 25	29.2	25.1	5.60	14.70	2
LLEHX 35	31.8	27.8	10.95	22.75	2

2 Guiding systems

Linear guiding system Speedi-Roll/Profile rail guides

LLEHE .. Z

Rollers

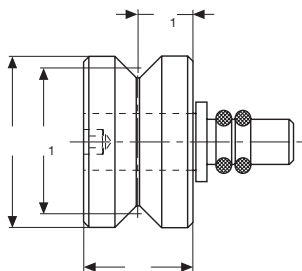

Designations	Dimensions			
	D	D ₁	A	A ₁
	mm			
LLEHE 15 Z	20.5	17.75	14.00	8.2
LLEHE 25 Z	22.0	19.25	14.00	9.0
LLEHE 35 Z	24.5	21.75	20.25	12.1

System with	Designations	Basic load ratings	
		dynamic C	static* C ₀
		N	
Standard carriage	LLEHS 15 H	2000	1200
Long carriage	LLEHS 15 L	2600	1800
Roller only	LLEHE 15	2850	1400
Standard carriage	LLEHS 25 H	4000	2700
Long carriage	LLEHS 25 L	5200	4000
Roller only	LLEHE 25	2850	1400
Standard carriage	LLEHS 35 H	6000	4250
Long carriage	LLEHS 35 L	8000	6350
Roller only	LLEHE 35	4400	2200

* Data for radial direction, load angle 90° or 270°, with load centrally applied to the carriage

Profile rail guides

Profile rail guides from SKF are modern machine components used in the production of linear guiding systems with unlimited travel (→ **figure 23**). They usually consist of a profile rail with four precision-ground raceways and a slide unit with four ball circulation paths. This design offers numerous benefits. The square configuration of the raceways results in a guidance system with good rigidity, capable of withstanding moment loads in all directions. The load-carrying capacity is equal in all four directions (→ **figure 24**). Ready-to-mount units guarantee economy and simplicity of mounting. Installation and adjustment procedures are reduced to a minimum. The design of the system is such that inaccuracies of the adjacent components can be accommodated. SKF profile rail guides are noted for their ease of maintenance and reliability. As standard, they are provided with grease nipple and seals on all sides. The two-point contact of the rolling elements with the raceways permits high operational speeds with quiet running and a low coefficient of friction. Good running accuracy is assured throughout the operational life of the system. Guides with specific preload can be supplied for special requirements. This is achieved through selection. Preload selection depends on the load and stiffness specifications.

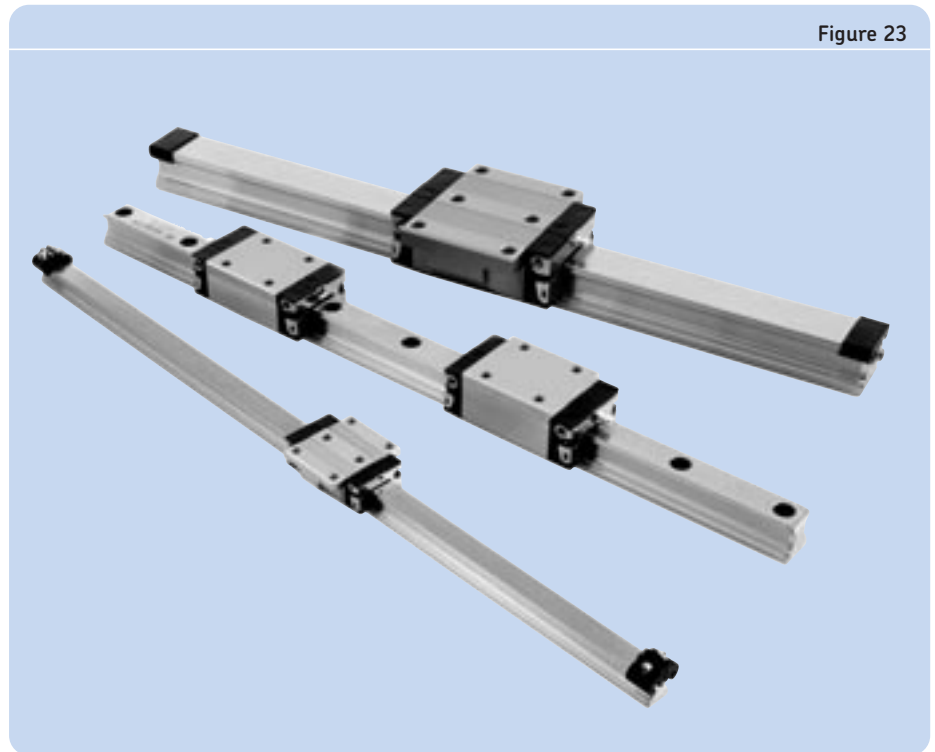

Figure 23

2

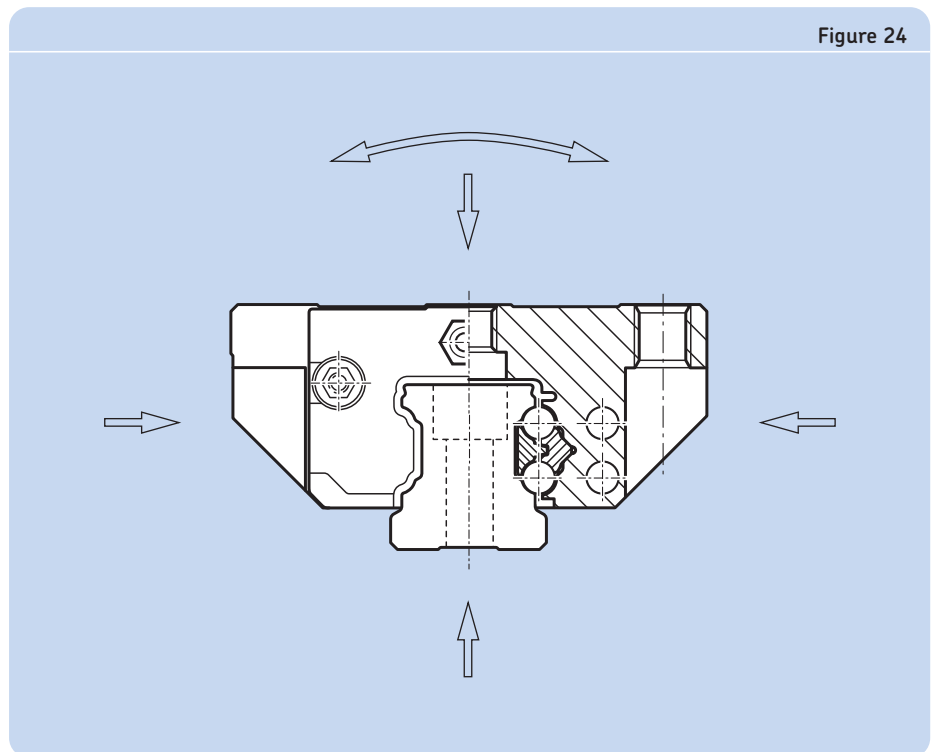

Figure 24

2 Guiding systems

Profile rail guides

Ordering key

LLR [] [] [] [] [] - [] [] [] []

Type

Product code:

Bellows (for bellows only) HB
 Carriage (carriage only) HC
 Rail (rail only) HR
 System (carriage and rail) HS
 Accessories, if order separately HZ

Size:

..... 15, 20, 25, 30, 35, 45

Carriage type:

Carriage, standard width A
 Carriage, standard width, short SA
 Carriage, standard width, long LA
 Carriage, slim line U
 Carriage, slim line, short SU
 Carriage, slim line, long LU
 Carriage, slim line, high R
 Carriage, slim line, high, long LR

Ball retainer:

Carriage with ball retainer B
 Carriage without ball retainer no sign

Number of carriages per rail track:

..... 1, 2, ..., n

Preload classes:

Up to 10 µm clearance, play T0
 Preload 0,02×C, light preload T1
 Preload 0,08×C, medium preload T2*
 Preload 0,12×C, high preload T3*

Rail length in mm

Precision class [for carriage and rail]:

Standard precision P5
 Medium precision P3
 High precision P1*
 Super precision P01*
 Ultra precision P001*

Number of parallel rail tracks:

One rail alone W1
 Two rails in parallel W2

Accessories & Option symbols:

Jointed rail track A
 Bellows, system complete with bellows B
 Bellow Kit, type 2 (carriage thru the end of the rail) B2
 Bellow Kit, type 4 (between two carriages) B4
 Rail, customized accessories to drawing number D
 Rail with cover strip and cover strip guard type 2 (aluminium) D2

Distance between end face and the first hole [mm]:

Symmetric holes as standard E = 0
 Carriage mounted on rail M
 Scraper plates S1
 Two piece front seals S2
 Seal Kit, two piece front seals with scraper plates S3

* On request

Example 1: LLR HB 25 - 15 Bellow only with 15 folds

Example 2: LLR HC 25 A T1 P5 Carriage only

Example 3: LLR HR 25 - 1000 P5 Rail only

Example 4: LLR HS 25 A T0 - 1000 P5 Complete system with carriage and rail

Example 5: LLR HS 25 A T0 - 1000 P5 W2 / D2 S2 Complete system incl. rail with cover strip and cover strip guard plus two piece front seals

Accessories for profile rail guides

Size	Items	Order number
15	LLRHZ 15 S1 Scraper plate	2241963
20	LLRHZ 20 S1 Scraper plate	2241964
25	LLRHZ 25 S1 Scraper plate	2241965
30	LLRHZ 30 S1 Scraper plate	2241966
35	LLRHZ 35 S1 Scraper plate	2241967
45	LLRHZ 45 S1 Scraper plate	2243324

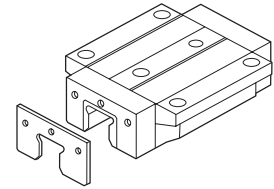

2

Size	Items	Order number
15	LLRHZ 15 S2 Two-piece front seal	2241951
20	LLRHZ 20 S2 Two-piece front seal	2241953
25	LLRHZ 25 S2 Two-piece front seal	2241955
30	LLRHZ 30 S2 Two-piece front seal	2241957
35	LLRHZ 35 S2 Two-piece front seal	2241959
45	LLRHZ 45 S2 Two-piece front seal	2243325

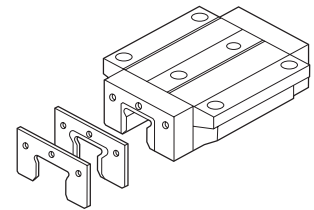

Size	Items	Order number
15	LLRHZ 15 Seal kit	2243158
20	LLRHZ 20 Seal kit	2243163
25	LLRHZ 25 Seal kit	2242080
30	LLRHZ 30 Seal kit	2242104
35	LLRHZ 35 Seal kit	2243232
45	LLRHZ 45 Seal kit	2243200

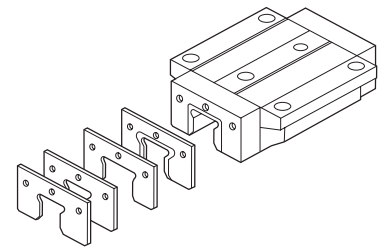

2 Guiding systems
Profile rail guides

LLRHS .. SA
LLRHS .. A
LLRHS .. LA

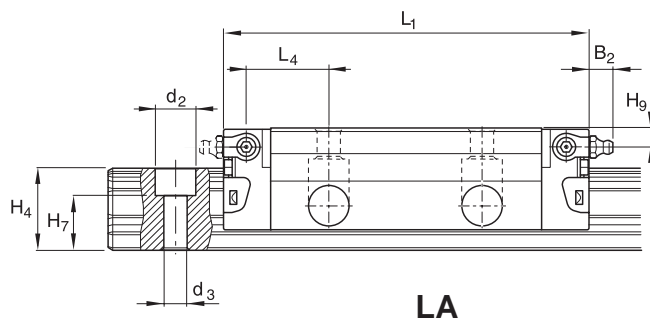

LA

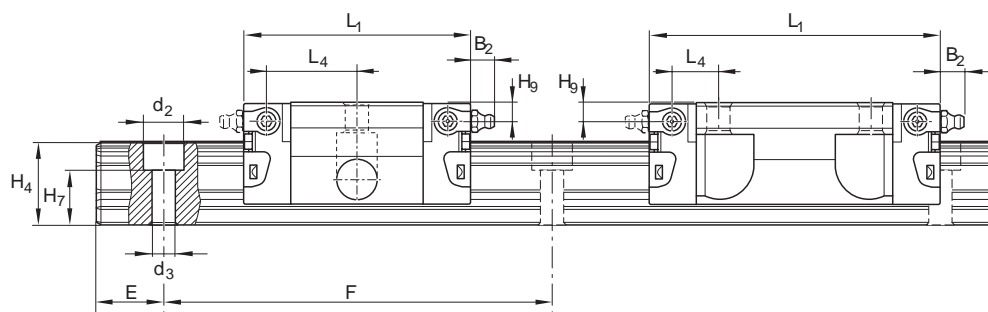
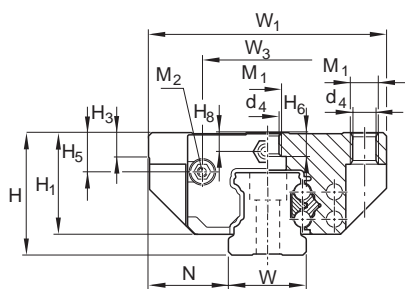

SA

A

Designations	Dimensions																		
	W ₁	W	N	L ₁	L ₂	H	H ₁	H ₄ ¹⁾	H ₄ ²⁾	H ₃	W ₂	L ₃	L ₅	W ₃	H ₅	L ₆	L ₄	H ₈	H ₉
mm																			
LLRHS 15 SA	47	15	16.0	44.7	25.7	24	19.90	16.30	16.20	5.0	38	-	-	24.55	6.70	16.25	17.85	3.20	3.20
LLRHS 15 A	47	15	16.0	58.2	39.2	24	19.90	16.30	16.20	5.0	38	30	26	24.55	6.70	8.00	9.60	3.20	3.20
LLRHS 15 LA	47	15	16.0	72.6	53.6	24	19.90	16.30	16.20	5.0	38	30	26	24.55	6.70	15.20	16.80	3.20	3.20
LLRHS 20 SA	63	20	21.5	57.3	31.9	30	25.35	20.75	20.55	6.0	53	-	-	32.50	7.30	22.95	22.95	3.35	3.35
LLRHS 20 A	63	20	21.5	75.0	49.6	30	25.35	20.75	20.55	6.0	53	40	35	32.50	7.30	11.80	11.80	3.35	3.35
LLRHS 20 LA	63	20	21.5	91.0	65.6	30	25.35	20.75	20.55	6.0	53	40	35	32.50	7.30	19.80	19.80	3.35	3.35
LLRHS 25 SA	70	23	23.5	67.0	38.6	36	29.90	24.45	24.25	7.5	57	-	-	38.30	11.50	25.35	26.50	5.50	5.50
LLRHS 25 A	70	23	23.5	86.2	57.8	36	29.90	24.45	24.25	7.5	57	45	40	38.30	11.50	12.45	13.60	5.50	5.50
LLRHS 25 LA	70	23	23.5	107.9	79.5	36	29.90	24.45	24.25	7.5	57	45	40	38.30	11.50	23.30	24.45	5.50	5.50
LLRHS 30 SA	90	28	31.0	75.3	45.0	42	35.35	28.55	28.35	7.0	72	-	-	48.40	14.60	28.80	30.50	6.05	6.05
LLRHS 30 A	90	28	31.0	97.7	67.4	42	35.35	28.55	28.35	7.0	72	52	44	48.40	14.60	14.00	15.70	6.05	6.05
LLRHS 30 LA	90	28	31.0	119.7	89.4	42	35.35	28.55	28.35	7.0	72	52	44	48.40	14.60	25.00	26.70	6.05	6.05
LLRHS 35 SA	100	34	33.0	84.9	51.4	48	40.40	32.15	31.85	8.0	82	-	-	58.00	17.35	32.70	34.20	6.90	6.90
LLRHS 35 A	100	34	33.0	110.5	77.0	48	40.40	32.15	31.85	8.0	82	62	52	58.00	17.35	14.50	16.00	6.90	6.90
LLRHS 35 LA	100	34	33.0	139.0	105.5	48	40.40	32.15	31.85	8.0	82	62	52	58.00	17.35	28.75	30.25	6.90	6.90
LLRHS 45 A*	120	45	37.5	137.6	97.0	60	50.30	40.15	39.85	10.0	100	80	60	69.80	20.90	17.30	19.30	8.20	8.20
LLRHS 45 LA*	120	45	37.5	174.1	133.5	60	50.30	40.15	39.85	10.0	100	80	60	69.80	20.90	35.50	37.50	8.20	8.20

¹⁾ With rail cover strip
²⁾ Without rail cover strip
* In preparation

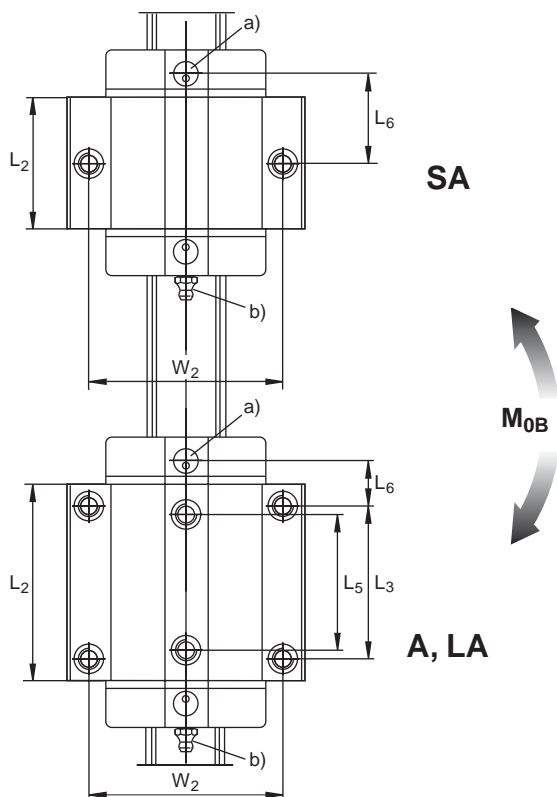

Legend:

- a) For O-ring
 - Size 15: $\text{Ø}4 \times 1.0$ (mm)
 - Size 20 - 35: $\text{Ø}5 \times 1.0$ (mm)
 - Open the lube hole if required.

- b) Lube nipple, size 15 and 20:
 - Funnel-type nipple
 - Type A – Thread size M3, DIN 3405
 - $B_2 = 1.6$ mm
 - Size 25 to 35: AM 6 DIN 71412
 - $B_2 = 9.5$ mm

Lubricating nipples form part of the delivery and have been included. When using other lubricating nipples, it is imperative to observe the correct screw depth of 8 mm.

Installation is possible at all sides.

Designations	Dimensions										Basic load ratings				Mass
	H ₆	H ₇	d ₄	M ₁	d ₂	d ₃	M ₂	E _{min}	F	C	C ₀	M _{0A/0B}	M _{0C}		
	± 0.5														
mm											N	Nm		kg	
LLRHS 15 SA	-	10.30	4.3	M5×5.2	7.4	4.4	M2.5 - 3.5 deep	10	60	5400	8100	28	80	0.15	
LLRHS 15 A	4.4	10.30	4.3	M5×5.2	7.4	4.4	M2.5 - 3.5 deep	10	60	7800	13500	71	130	0.20	
LLRHS 15 LA	4.4	10.30	4.3	M5×5.2	7.4	4.4	M2.5 - 3.5 deep	10	60	10000	20000	150	190	0.30	
LLRHS 20 SA	-	13.20	5.3	M6×7.7	9.4	6.0	M3 - 5 deep	10	60	12400	13600	58	170	0.30	
LLRHS 20 A	5.2	13.20	5.3	M6×7.7	9.4	6.0	M3 - 5 deep	10	60	18800	24400	165	310	0.45	
LLRHS 20 LA	5.2	13.20	5.3	M6×7.7	9.4	6.0	M3 - 5 deep	10	60	24400	35200	330	450	0.55	
LLRHS 25 SA	-	15.20	6.7	M8×9.3	11.0	7.0	M3 - 5 deep	10	60	15900	18200	94	260	0.50	
LLRHS 25 A	7.0	15.20	6.7	M8×9.3	11.0	7.0	M3 - 5 deep	10	60	22800	30400	240	430	0.65	
LLRHS 25 LA	7.0	15.20	6.7	M8×9.3	11.0	7.0	M3 - 5 deep	10	60	30400	45500	510	650	0.90	
LLRHS 30 SA	-	17.00	8.5	M10×11.0	15.0	9.0	M3 - 5 deep	12	80	22100	24800	150	430	0.80	
LLRHS 30 A	7.9	17.00	8.5	M10×11.0	15.0	9.0	M3 - 5 deep	12	80	31700	41300	380	720	1.10	
LLRHS 30 LA	7.9	17.00	8.5	M10×11.0	15.0	9.0	M3 - 5 deep	12	80	40000	57800	715	1000	1.50	
LLRHS 35 SA	-	20.50	8.5	M10×12.0	15.0	9.0	M3 - 5 deep	12	80	29300	32400	220	700	1.20	
LLRHS 35 A	10.2	20.50	8.5	M10×12.0	15.0	9.0	M3 - 5 deep	12	80	41900	54000	565	1160	1.60	
LLRHS 35 LA	10.2	20.50	8.5	M10×12.0	15.0	9.0	M3 - 5 deep	12	80	55600	81000	1215	1740	2.25	
LLRHS 45 A*	14.4	23.50	10.4	M12×15.0	20.0	14.0	M4 - 7 deep	16	105	68100	85700	1130	2310	3.00	
LLRHS 45 LA*	12.4	23.50	10.4	M12×15.0	20.0	14.0	M4 - 7 deep	16	105	90400	128500	2425	3470	4.30	

2 Guiding systems
Profile rail guides

LLRHS .. SU
LLRHS .. U
LLRHS .. LU

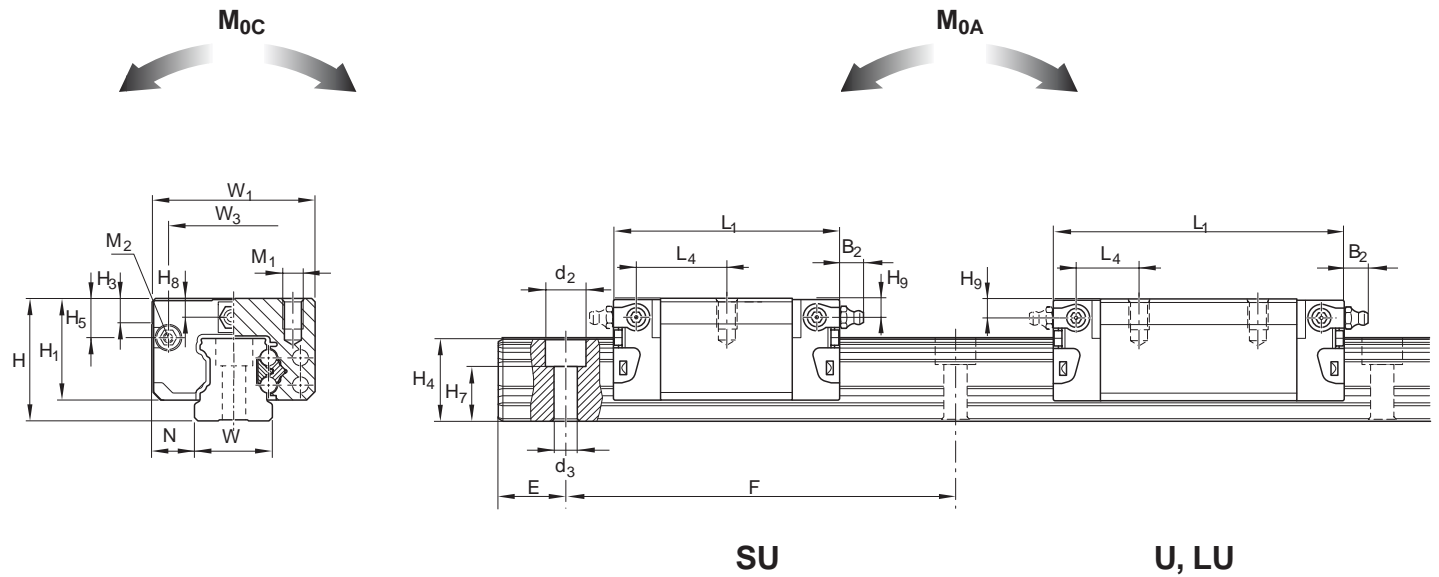

Designations	Dimensions																	
	W ₁	W	N	L ₁	L ₂	H	H ₁	H ₄ ¹⁾	H ₄ ²⁾	H ₃	W ₂	L ₃	W ₃	H ₅	L ₆	L ₄	H ₈	H ₉
mm																		
LLRHS 15 SU	34	15	9.5	44.7	25.7	24	19.90	16.30	16.20	5.0	26	-	24.55	6.70	16.25	17.85	3.20	3.20
LLRHS 15 U	34	15	9.5	58.2	39.2	24	19.90	16.30	16.20	5.0	26	26	24.55	6.70	10.00	11.60	3.20	3.20
LLRHS 15 LU	34	15	9.5	72.6	53.6	24	19.90	16.30	16.20	5.0	26	26	24.55	6.70	17.20	18.80	3.20	3.20
LLRHS 20 SU	44	20	12.0	57.3	31.9	30	25.35	20.75	20.55	6.0	32	-	32.50	7.30	22.95	22.95	3.35	3.35
LLRHS 20 U	44	20	12.0	75.0	49.6	30	25.35	20.75	20.55	6.0	32	36	32.50	7.30	13.80	13.80	3.35	3.35
LLRHS 20 LU	44	20	12.0	91.0	65.6	30	25.35	20.75	20.55	6.0	32	50	32.50	7.30	14.80	14.80	3.35	3.35
LLRHS 25 SU	48	23	12.5	67.0	38.6	36	29.90	24.45	24.25	7.5	35	-	38.30	11.50	25.35	26.50	5.50	5.50
LLRHS 25 U	48	23	12.5	86.2	57.8	36	29.90	24.45	24.25	7.5	35	35	38.30	11.50	17.45	18.60	5.50	5.50
LLRHS 25 LU	48	23	12.5	107.9	79.5	36	29.90	24.45	24.25	7.5	35	50	38.30	11.50	20.80	21.95	5.50	5.50
LLRHS 30 SU	60	28	16.0	75.3	45.0	42	35.35	28.55	28.35	7.0	40	-	48.40	14.60	28.80	30.50	6.05	6.05
LLRHS 30 U	60	28	16.0	97.7	67.4	42	35.35	28.55	28.35	7.0	40	40	48.40	14.60	20.00	21.70	6.05	6.05
LLRHS 30 LU	60	28	16.0	119.7	89.4	42	35.35	28.55	28.35	7.0	40	60	48.40	14.60	21.00	22.70	6.05	6.05
LLRHS 35 SU	70	34	18.0	84.9	51.4	48	40.40	32.15	31.85	8.0	50	-	58.00	17.35	32.70	34.20	6.90	6.90
LLRHS 35 U	70	34	18.0	110.5	77.0	48	40.40	32.15	31.85	8.0	50	50	58.00	17.35	20.50	22.00	6.90	6.90
LLRHS 35 LU	70	34	18.0	139.0	105.5	48	40.40	32.15	31.85	8.0	50	72	58.00	17.35	23.75	25.25	6.90	6.90
LLRHS 45 U*	86	45	20.5	137.6	97.0	60	50.30	40.15	39.85	10.0	60	60	69.80	20.90	27.30	29.30	8.20	8.20
LLRHS 45 LU*	86	45	20.5	174.1	133.5	60	50.30	40.15	39.85	10.0	60	80	69.80	20.90	35.50	37.50	8.20	8.20

¹⁾ With rail cover strip
²⁾ Without rail cover strip
* In preparation

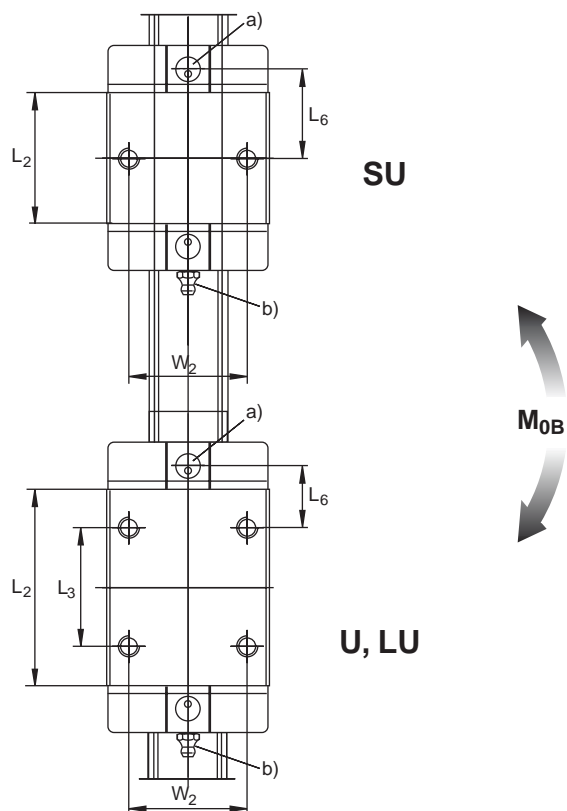

Legend:

- a) For O-ring
 - Size 15: $\varnothing 4 \times 1.0$ (mm)
 - Size 20 - 35: $\varnothing 5 \times 1.0$ (mm)
 - Open the lube hole if required.

- b) Lube nipple, size 15 and 20:
 - Funnel-type nipple
 - Type A - Thread size M3, DIN 3405
 - $B_2 = 1.6$ mm
 - Size 25 to 35: AM 6 DIN 71412
 - $B_2 = 9.5$ mm

Lubricating nipples form part of the delivery and have been included. When using other lubricating nipples, it is imperative to observe the correct screw depth of 8 mm.

Installation is possible at all sides.

Designations	Dimensions		d_2	d_3	M_2	E_{min}	F	Basic load ratings				Mass
	H_7 ± 0.5	M_1						C	C_0	$M_{0A/0B}$	M_{0C}	
	mm							N		Nm		
LLRHS 15 SU	10.30	M4×6.0	7.4	4.4	M2.5 - 3.5 deep	10	60	5400	8100	28	80	0.10
LLRHS 15 U	10.30	M4×6.0	7.4	4.4	M2.5 - 3.5 deep	10	60	7800	13500	71	130	0.15
LLRHS 15 LU	10.30	M4×6.0	7.4	4.4	M2.5 - 3.5 deep	10	60	10000	20200	150	190	0.20
LLRHS 20 SU	13.20	M5×7.5	9.4	6.0	M3 - 5 deep	10	60	12400	13600	58	170	0.25
LLRHS 20 U	13.20	M5×7.5	9.4	6.0	M3 - 5 deep	10	60	18800	24400	165	310	0.35
LLRHS 20 LU	13.20	M5×7.5	9.4	6.0	M3 - 5 deep	10	60	24400	35200	330	450	0.45
LLRHS 25 SU	15.20	M6×9.0	11.0	7.0	M3 - 5 deep	10	60	15900	18200	94	260	0.35
LLRHS 25 U	15.20	M6×9.0	11.0	7.0	M3 - 5 deep	10	60	22800	30400	240	430	0.50
LLRHS 25 LU	15.20	M6×9.0	11.0	7.0	M3 - 5 deep	10	60	30400	45500	510	650	0.65
LLRHS 30 SU	17.00	M8×12.0	15.0	9.0	M3 - 5 deep	12	80	22100	24800	150	430	0.60
LLRHS 30 U	17.00	M8×12.0	15.0	9.0	M3 - 5 deep	12	80	31700	41300	380	720	0.85
LLRHS 30 LU	17.00	M8×12.0	15.0	9.0	M3 - 5 deep	12	80	40000	57800	715	1000	1.10
LLRHS 35 SU	20.50	M8×13.0	15.0	9.0	M3 - 5 deep	12	80	29300	32400	220	700	0.90
LLRHS 35 U	20.50	M8×13.0	15.0	9.0	M3 - 5 deep	12	80	41900	54000	565	1160	1.25
LLRHS 35 LU	20.50	M8×13.0	15.0	9.0	M3 - 5 deep	12	80	55600	81000	1215	1740	1.70
LLRHS 45 U*	23.50	M10×18.0	20.0	14.0	M4 - 7 deep	16	105	68100	85700	1130	2310	2.40
LLRHS 45 LU*	23.50	M10×18.0	20.0	14.0	M4 - 7 deep	16	105	90400	128500	2425	3470	3.20

2 Guiding systems
Profile rail guides

LLRHS .. R
LLRHS .. LR

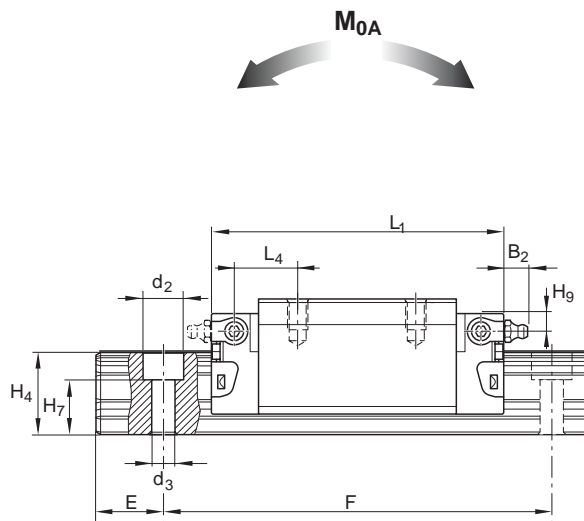
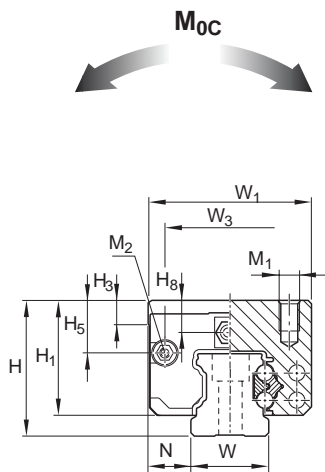

R, LR

Designations	Dimensions																	
	W ₁	W	N	L ₁	L ₂	H	H ₁	H ₄ ¹⁾	H ₄ ²⁾	H ₃	W ₂	L ₃	W ₃	H ₅	L ₆	L ₄	H ₈	H ₉
mm																		
LLRHS 15 R	34	15	9.5	58.2	39.2	28	23.90	16.30	16.20	5.0	26	26	24.55	10.70	10.00	11.60	7.20	7.20
LLRHS 25 R	48	23	12.5	86.2	57.8	40	33.90	24.45	24.25	7.5	35	35	38.30	15.50	17.45	18.60	9.50	9.50
LLRHS 25 LR	48	23	12.5	107.9	79.5	40	33.90	24.45	24.25	7.5	35	50	38.30	15.50	20.80	21.95	9.50	9.50
LLRHS 30 R	60	28	16.0	97.7	67.4	45	38.35	28.55	28.35	7.0	40	40	48.40	17.60	20.00	21.70	9.05	9.05
LLRHS 30 LR	60	28	16.0	119.7	89.4	45	38.35	28.55	28.35	7.0	40	60	48.40	17.60	21.00	22.70	9.05	9.05
LLRHS 35 R	70	34	18.0	110.5	77.0	55	47.40	32.15	31.85	8.0	50	50	58.00	24.35	20.50	22.00	13.90	13.90
LLRHS 35 LR	70	34	18.0	139.0	105.5	55	47.40	32.15	31.85	8.0	50	72	58.00	24.35	23.75	25.25	13.90	13.90
LLRHS 45 R*	86	45	20.5	137.6	97.0	70	60.30	40.15	39.85	10.0	50	60	69.80	30.90	27.30	29.30	18.20	18.20
LLRHS 45 LR*	86	45	20.5	174.1	133.5	70	60.30	40.15	39.85	10.0	60	80	69.80	30.90	35.50	37.50	18.20	18.20

¹⁾ With rail cover strip
²⁾ Without rail cover strip
* In preparation

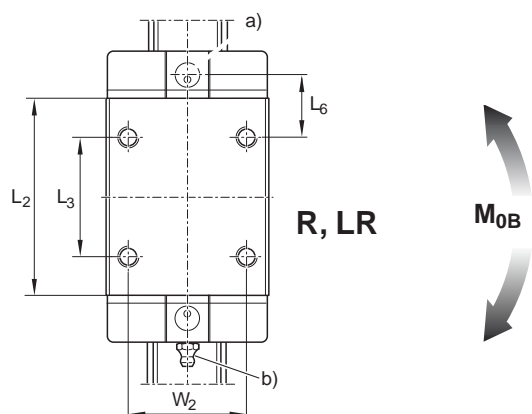

Legend:

- a) For O-ring
 - Size 15: $\varnothing 4 \times 1.0$ (mm)
 - Size 20 - 35: $\varnothing 5 \times 1.0$ (mm)
 - Open the lube hole if required.
 - See Accessories:
 - Mounting lubrication adapter.

- b) Lube nipple, size 15 and 20:
 - Funnel-type nipple
 - Type A - Thread size M3, DIN 3405
 - $B_2 = 1.6$ mm
 - Size 25 to 35: AM 6 DIN 71412
 - $B_2 = 9.5$ mm

Lubricating nipples form part of the delivery and have been included. When using other lubricating nipples, it is imperative to observe the correct screw depth of 8 mm.

Installation is possible at all sides.

Designations	Dimensions		d_2	d_3	M_2	E_{min}	F	Basic load ratings				Mass
	H_7 ± 0.5	M_1						C	C_0	$M_{0A/0B}$	M_{0C}	
	mm							N		Nm		kg
LLRHS 15 R	10.30	M4×6.0	7.4	4.4	M2.5 - 3.5 deep	10	60	7800	13500	71	130	0.20
LLRHS 25 R	15.20	M6×9.0	11.0	7.0	M3 - 5 deep	10	60	22800	30400	240	430	0.60
LLRHS 25 LR	15.20	M6×9.0	11.0	7.0	M3 - 5 deep	10	60	30400	45500	510	650	0.80
LLRHS 30 R	17.00	M8×12.0	15.0	9.0	M3 - 5 deep	12	80	31700	41300	380	720	0.95
LLRHS 30 LR	17.00	M8×12.0	15.0	9.0	M3 - 5 deep	12	80	40000	57800	715	1000	1.20
LLRHS 35 R	20.50	M8×13.0	15.0	9.0	M3 - 5 deep	12	80	41900	54000	565	1160	1.55
LLRHS 35 LR	20.50	M8×13.0	15.0	9.0	M3 - 5 deep	12	80	55600	81000	1215	1740	2.10
LLRHS 45 R*	23.50	M10×18.0	20.0	14.0	M4 - 7 deep	16	105	68100	85700	1130	2310	3.00
LLRHS 45 LR*	23.50	M10×18.0	20.0	14.0	M4 - 7 deep	16	105	90400	128500	2425	3470	4.10

2 Guiding systems

Miniature profile rail guides

Miniature profile rail guides

In response to the market trend for increased performance with a minimum of mounting space, SKF has extended its product range by miniature profile rail guides (→ figure 25).

These newly developed linear guides are designed above all for applications in precision mechanics, medical engineering, microassembly and the optics industry.

The close co-operation with numerous customers combined with SKF's experience has resulted in a range of miniature rail guides that sets new standards: especially when the mounting space is limited, SKF miniature profile rail guides are an excellent choice, as they have a high load-carrying capacity combined with a compact design.

SKF offers its customers an excellent technical advisory service on the spot as well as a vast modular range for the performance increase of machines and installations.

SKF Linear Motion offers these profile rail guides in four sizes (7, 9, 12 and 15 mm) and various slide options to cover most application requirements.

Compact design: thanks to their simple structure, miniature profile rail guides are compact and favourable in price. This small and lightweight product is very suitable for high-speed linear motion up to 3 m/sec.

Long-life: gothic arch grooves at the raceway contacts enable the slide to sustain loads and moments from any direction.

The raceway shape offers a large load capacity and a long-life time due to the contact between the raceways and the balls.

Corrosion resistant: all parts of the system are made of stainless steel or plastic material and are thus resistant to corrosion.

Easy to maintain: oil holes in the end caps of the carriage make it easy to relubricate the system.

Structure: four-point contact ball recirculation system with identical load

Figure 25

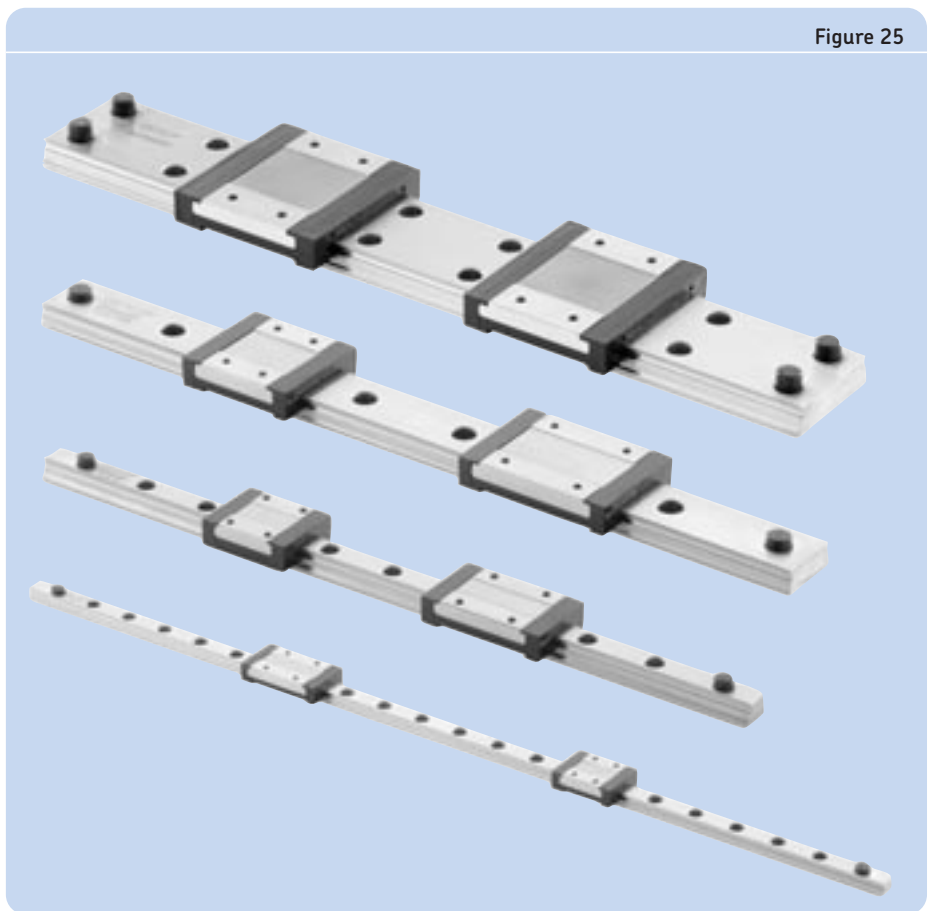

angles and 2 ball recirculation paths per carriage for unlimited stroke.

Range: four different types (7, 9, 12, 15) comprising different widths and carriage lengths (→ figure 26).

Figure 26

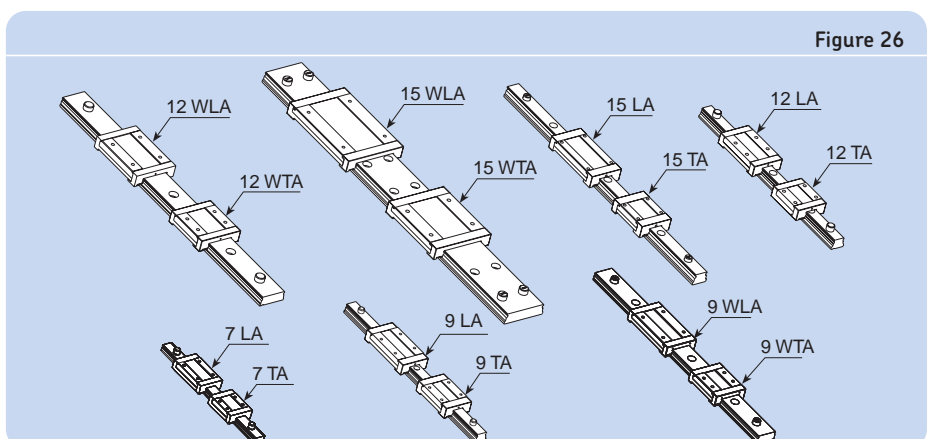

The preload possibilities for carriage are given in **Table 16**, and the technical data in **Table 17**.

	T0*	T1*	T2*
TA	×	×	×
LA	×	×	×

* T0 = standard - light preload
 * T1 = medium preload
 * T2 = heavy preload

Rail material:	Stainless steel 1.4034
Carriage material:	Stainless steel 1.4034 with return zones of POM
Ball material:	Stainless steel 1.4034
Sealing material:	Desmopan
Temperature range:	from - 20 °C up to + 80 °C
Speed:	up to 3 m/s max.
Acceleration:	up to 80 m/s ² max.

Preload possibilities for carriage

Technical data

The system accuracy and the system tolerance of different guidance system are given in **Table 18**.

System accuracy

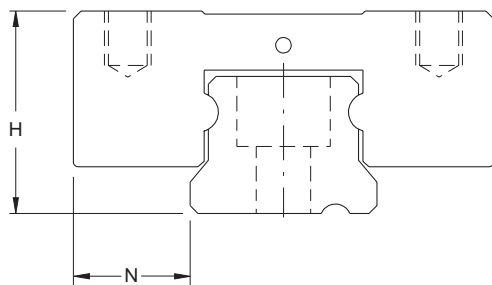

System tolerance

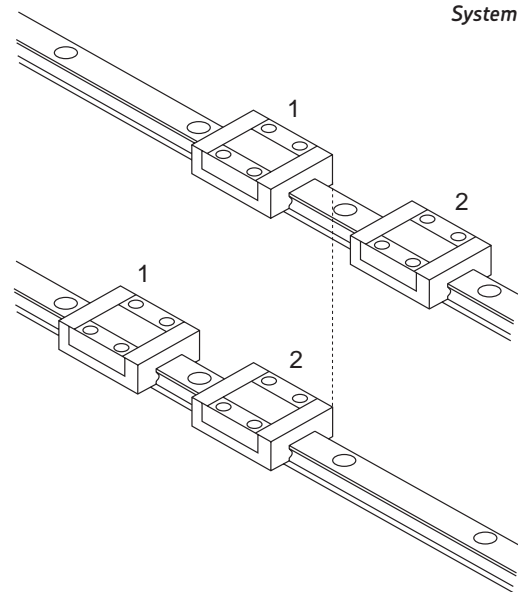

Dimension		Class	
		P1	P5
		µm	µm
H*	Dimension tolerance	± 10	± 20
N*	Dimension tolerance	± 15	± 25
ΔH ₁ **	Maximum tolerance for paired systems or carriages at identical rail position	± 7	± 15
ΔN**	Maximum tolerance for paired systems or carriages at identical rail position	± 7	± 15

* The tolerances apply over the entire guide length for any combination of carriage and rail.
 ** The dimensions ΔH and ΔN relate to the ideal centre of the carriage. Each dimension is derived from the mean value of two measured points with identical centre distance.

System accuracy and tolerance of different guidance systems

2 Guiding systems

Miniature profile rail guides

The running parallelism accuracy in operation of paired systems are given in **Table 19**.

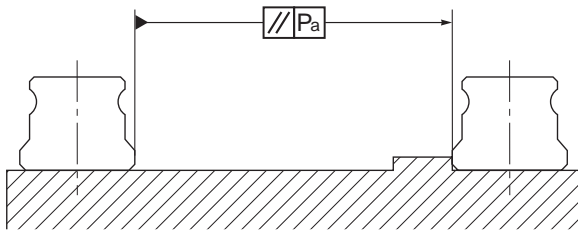
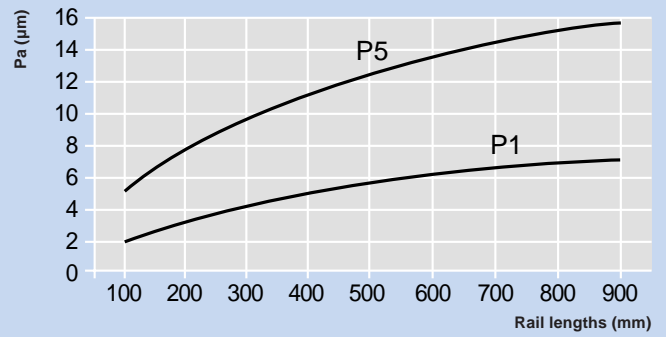

Table 19



Running parallelism accuracy

The positioning (distance) tolerance of rail attachment holes can be seen from **figure 27**.

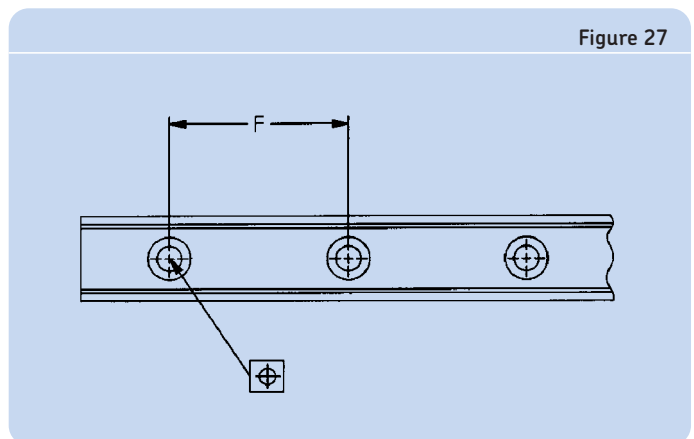

Figure 27

2 Guiding systems

Miniature profile rail guides

LLMHR

Standard rails

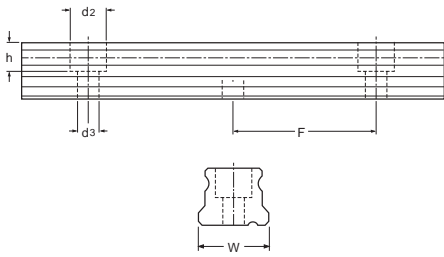

Designations	Dimensions					Max. length
	W	F	d ₂	d ₃	h	
	mm					mm
LLMHR 7	7	15	4.5	2.5	2.5	1000
LLMHR 9	9	20	6	3.5	3.5	1000
LLMHR 12	12	25	6	3.5	4.5	1000
LLMHR 15	15	40	6	3.5	4.5	1000

LLMWR

Wide rails

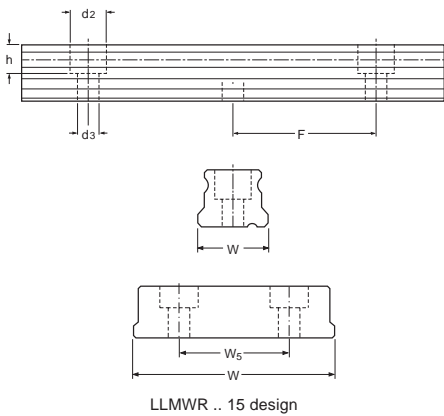

Designations	Dimensions						Max. length
	W	W ₅	F	d ₂	d ₃	h	
	mm						mm
LLMWR 9	18	0	30	6	3.5	4.5	1000
LLMWR 12	24	0	40	8	4.5	4.5	1000
LLMWR 15	42	23	40	8	4.5	4.5	1000

LLMHC .. TA

Standard carriages

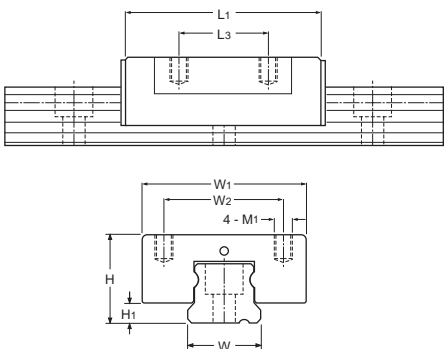

Designations	Dimensions								Load-carrying capacities	
	W	W ₁	W ₂	H	L ₁	L ₃	M ₁	H ₁	dynamic C	static C ₀
	mm								N	
LLMHC 7 TA	7	17	12	8	22	8	M2×2.5	1.5	860	1670
LLMHC 9 TA	9	20	15	10	30	10	M3×3	2	1850	3130
LLMHC 12 TA	12	27	20	13	33	15	M3×3.5	3	2550	4000
LLMHC 15 TA	15	32	25	16	41.5	20	M3×4	4	2880	5390

LLMWC .. TA

Carriages for wide rails

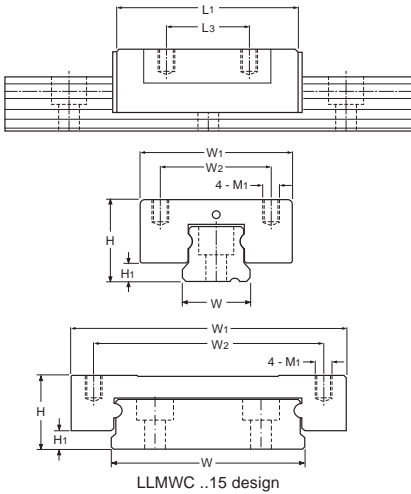

Designations	Dimensions								Load-carrying capacities	
	W	W ₁	W ₂	H	L ₁	L ₃	M ₁	H ₁	dynamic C	static C ₀
	mm								N	
LLMWC 9 TA	18	30	21	12	36.5	12	M3×3	2	1785	3330
LLMWC 12 TA	24	40	28	14	42.5	15	M3×3.5	3	3300	5780
LLMWC 15 TA	42	60	45	16	51.2	20	M4×4.5	4	3890	7060

LLMHC .. LA

Long carriages

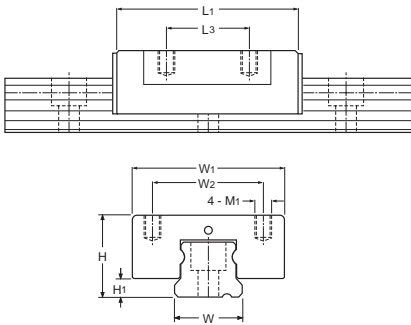

Designations	Dimensions								Load-carrying capacities	
	W	W ₁	W ₂	H	L ₁	L ₃	M ₁	H ₁	dynamic C	static C ₀
	mm								N	
LLMHC 7 LA	7	17	12	8	29.5	12	M2×2.5	1.5	1400	2700
LLMHC 9 LA	9	20	15	10	38.5	15	M3×3	2	2295	4270
LLMHC 12 LA	12	27	20	13	45	20	M3×3.5	3	3470	6225
LLMHC 15 LA	15	32	25	16	57.5	25	M3×4	4	4670	8720

LLMWC .. LA

Long carriages for wide rails

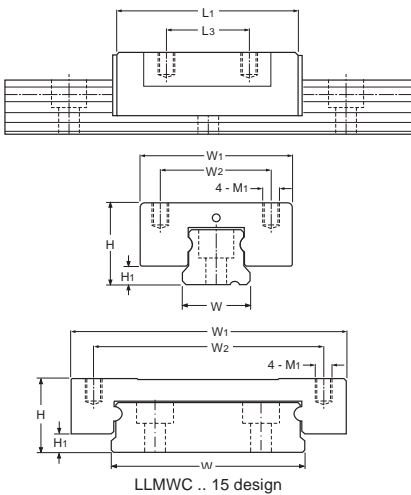

Designations	Dimensions								Load-carrying capacities	
	W	W ₁	W ₂	H	L ₁	L ₃	M ₁	H ₁	dynamic C	static C ₀
	mm								N	
LLMWC 9 LA	18	30	23	12	48.5	24	M3×3	2	2640	4900
LLMWC 12 LA	24	40	28	14	56	28	M3×3.5	3	4150	8000
LLMWC 15 LA	42	60	45	16	70.5	35	M4×4.5	4	5830	10600

Precision rail guides

Modular range rail guides

The modular range (→ **figure 28**) consists of a matrix range of rail guide modules which enable an individual choice of combinations of rails and rolling element assemblies. Different requirements for the guides do not call for changes in the design or mechanical environment. Selection of the right rail guide is made depending on the mechanical conditions of the application in question.

The operating requirements are covered by five different models which may be defined as rail guides with:

- crossed roller cage assemblies of the standard LWR series
- ball cage assemblies of the LWR series
- crossed roller cage assemblies of the optimised LWRE series
- needle roller cage assemblies of the LWRM/LWRV series
- slideway liners of the LWRPM/LWRPV series.

Precision rail guides are suitable for applications with limited strokes requiring high stiffness and positioning accuracy.

The modular range series of rails makes it possible to select internal design and/or rolling assemblies to suit application requirements without changing the envelope dimensions of the rails.

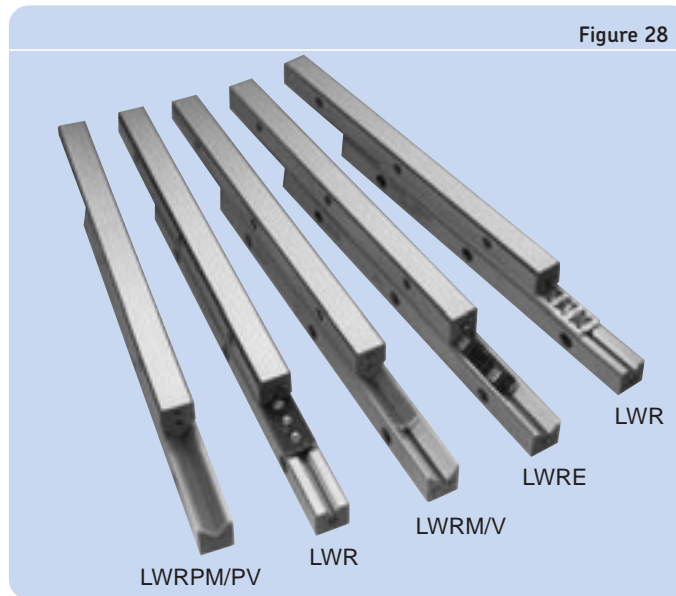

Anti-creeping systems (ACS systems)

The ACS system prevents cage creeping (→ **figure 29**). It is available for any product from the LWRE range.

The modular rail range, which is completely interchangeable, is given in **Table 20**. This range is suitable for applications with limited strokes requiring high stiffness and positioning accuracy.

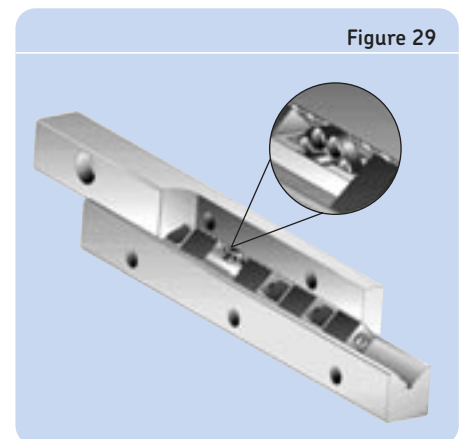

Table 20

Modular range: interchangeable rail programme	Basic load rating	Speed	Noise	Stiffness	Precision
Crossed rollers LWR					
Crossed rollers LWRE					
Needle rollers					
Sliding liners					

Ordering key

LW				
----	--	--	--	--

Type

Designation type:

Rail guide (modular range) (sizes: 3/6/9/12/15/18/24)	R
Rail guide (modular range) (sizes: 1/2)	RB
Plastic ball-retaining cage (sizes: 1/2/3/6/9/12)	JK
Brass ball cage (sizes: 1/2)	JJ
Crossed rollers in plastic cage (sizes: 3)	AK
Crossed rollers in aluminium cage (sizes: 6/9/12)	AL
End piece for low load and horizontal mounting (sizes: 1/2/3/6/9/12/15/18/24)	ERA
Special attachment screw (sizes: 3/4/6/9/12/15/18/24)	GD

Rail guide (modular range) (sizes old designation: 3/4/6/9)	RE*
Rail guide (modular range) (sizes new designation: 1808/2211/2512/3115/4422)	LW*
Flexible crossed roller plastic cages (sizes: 3/4/6/9)	AKE
End piece for general use (sizes: 3/4/6/9/2211)	ERE
Special attachment screw (sizes: 3/4/6/9/2211)	GD

Rail guide for needle roller assemblies (modular range) (sizes: 6/9)	RM
Rail guide for needle roller assemblies (modular range) (sizes: 6/9)	RV
Needle rollers in aluminium cage (sizes: 6/9)	HW
End piece with plastic wiper for general use (sizes: 6/9)	EARM
End piece with plastic wiper for general use (sizes: 6/9)	EARV
Special attachment screw (sizes: 6/9)	GD

Rail guide (sizes: 3015/4020/5025/6030/7040/8050)	M
Rail guide (sizes: 3015/4020/5025/6030/7040/8050)	V
Needle rollers in aluminium cage (sizes: 10/15/20/25/30)	HW
End piece with wiper for general use (sizes: 3015/4020/5025/6030/7040/8050)	EAM
End piece with wiper for general use (sizes: 3015/4020/5025/6030/7040/8050) DIN 84	EAV

Size:**

Specific values are reported on designation type

Length rail guide [mm]:

For R	20 - 1000
For RE*	50 - 1000
For RM	100 - 1000
For RV	100 - 1000

Option:

For R	{ for size 3/6	KIT
For RE	{ for size 3/4/6	KIT
	{ anti-creeping system	ACS
	{ for size 3/4/6	ACS-KIT

For information of further products and accessories please contact our customer service.

- LWN / LWO (sizes 2025-, 2535-, 3045- and 3555-)
- LWML series
- LWF / LWG series (sizes 412-, 612-, 624-, 1024- and 1434-)

Example 1, rail guide: LW RE 6 350 ACS

Example 2, cage: LW AKE 6 350

Example 3, end piece: LW ERE 6 x 24

Example 4, screws: LW GD 6

Designation		Length	
New	Old	A	B
LW 1808	RE 3	18	08
LW 2211	—	22	11
LW 2512	RE 4	25	12
LW 3115	RE 6	31	15
LW 4422	RE 9	44	22

** Sizes 3 (1808), 2211; 4 (2512); 6 (3115) = 3 digits for length of rail; example: 050
100
...
Size 9 (4422) = 4 digits for length of rail; example: 0050
0100
...
1000

Size 3015 3 digits for length of rail; example: 3015100
3015150
...
bigger sizes 4 digits for length of rail!; example: 25350100
...

2 Guiding systems

Precision rail guides

LWR .. / LWRB ..

LWR rail guides are well-proven, limited-travel, linear guides used in numerous applications. They consist of two identical rails between which crossed roller assemblies or ball assemblies are inserted, depending on the application and size.

LWR rail guides with crossed roller assembly are robust linear bearings with high load-carrying capacity. Their special characteristics make them suitable for a large proportion of linear bearing arrangements with limited travel.

LWRB rail guides with ball assembly can be used to advantage where loads are light and easy running is required.

They are available for sizes 1 and 2.

Each part of an LWR rail guide system must be ordered separately, because of the large number of possible combinations of

- 4 rails LWR
- 2 crossed roller cage assemblies LWAL
- 8 end pieces LWERA.

LWR .. KIT

The KIT package for the modular range is a unique service provided only by SKF.

Rails

LWR 3-12

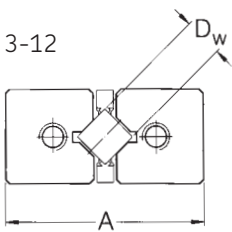

LWRB 1+2

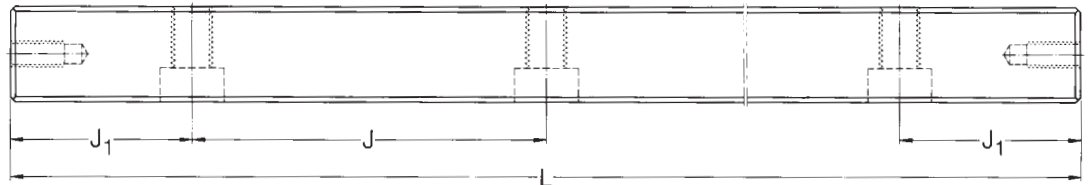
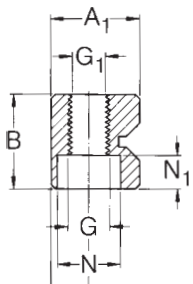
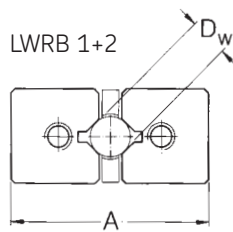

Ball and crossed roller assemblies

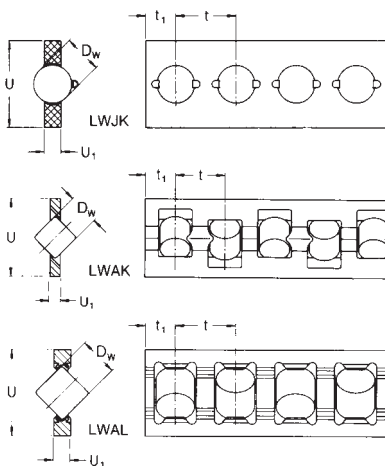

End pieces

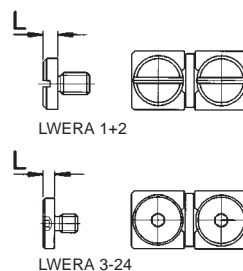

Special attachment screw

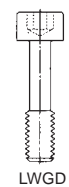

LWR 3/6 .. KIT

4 rail guides LWR
 2 crossed roller cage assemblies
 LWAL/LWAK
 8 end pieces LWERA

See page 82 for drawing

Designations	Load ratings*		Stroke		Rail designations	Cage designations
	dynamic C	static C ₀	min.	max.		
	N		mm			
LWR 3050 KIT	999	1120	26	33	LWR 3050	LWAK 3×7
LWR 3075 KIT	1422	1760	36	50	LWR 3075	LWAK 3×11
LWR 3100 KIT	1811	2400	46	67	LWR 3100	LWAK 3×15
LWR 3125 KIT	2088	2880	66	83	LWR 3125	LWAK 3×18
LWR 3150 KIT	2442	3520	76	100	LWR 3150	LWAK 3×22
LWR 3175 KIT	2781	4160	86	117	LWR 3175	LWAK 3×26
LWR 3200 KIT	3110	4800	96	133	LWR 3200	LWAK 3×30

* Load ratings for 10 rolling elements
 Including 8 end stops LWERA 3

2

Designations	Load ratings*		Stroke		Rail designations	Cage designations
	dynamic C	static C ₀	min.	max.		
	N		mm			
LWR 6100 KIT	4915	5440	50	67	LWR 6100	LWAL 6×8
LWR 6150 KIT	6744	8160	78	100	LWR 6150	LWAL 6×12
LWR 6200 KIT	8441	10880	106	133	LWR 6200	LWAL 6×16
LWR 6250 KIT	10045	13600	134	167	LWR 6250	LWAL 6×20
LWR 6300 KIT	11955	17000	144	200	LWR 6300	LWAL 6×25
LWR 6350 KIT	13422	19720	172	233	LWR 6350	LWAL 6×29
LWR 6400 KIT	14846	22440	200	267	LWR 6400	LWAL 6×33

* Load ratings for 10 rolling elements
 Including 8 end stops LWERA 6

See page 82 for drawing

2 Guiding systems
Precision rail guides

LWRB 1

Designations	Dimensions															Load ratings*	
	A	B	L	L ₁	J	J ₁	G	G ₁	N	N ₁	A ₁	D _w	U	U ₁	t	dynamic C	static C ₀
	mm															N	
Rails																	
LWRB 1020	8.5	4	20		10	5	M2	1.7	3	1.4	3.9						
LWRB 1030	8.5	4	30		10	5	M2	1.7	3	1.4	3.9						
LWRB 1040	8.5	4	40		10	5	M2	1.7	3	1.4	3.9						
LWRB 1050	8.5	4	50		10	5	M2	1.7	3	1.4	3.9						
LWRB 1060	8.5	4	60		10	5	M2	1.7	3	1.4	3.9						
Ball assemblies																	
LWJK 1,588												1.588	3.5	0.5	2.2	410	580
End pieces																	
LWERA 1				1	-												

* Load ratings for 10 rolling elements

See page 82
for drawing

LWRB 2

Designations	Dimensions															Load ratings*	
	A	B	L	L ₁	J	J ₁	G	G ₁	N	N ₁	A ₁	D _w	U	U ₁	t	dynamic C	static C ₀
	mm															N	
Rails																	
LWRB 2030	12	6	30		15	7.5	M3	2.6	4.4	2	5.5						
LWRB 2045	12	6	45		15	7.5	M3	2.6	4.4	2	5.5						
LWRB 2060	12	6	60		15	7.5	M3	2.6	4.4	2	5.5						
LWRB 2075	12	6	75		15	7.5	M3	2.6	4.4	2	5.5						
LWRB 2090	12	6	90		15	7.5	M3	2.6	4.4	2	5.5						
LWRB 2105	12	6	105		15	7.5	M3	2.6	4.4	2	5.5						
LWRB 2120	12	6	120		15	7.5	M3	2.6	4.4	2	5.5						
Ball assemblies																	
LWJK 2												2	5	0.75	3.0	640	720
End pieces																	
LWERA 2				1.5	-												

* Load ratings for 10 rolling elements

See page 82
for drawing

LWR 3

Designations	Dimensions															Load ratings*	
	A	B	L	L ₁	J	J ₁	G	G ₁	N	N ₁	A ₁	D _W	U	U ₁	t	dynamic C	static C ₀
	mm															N	
Rails																	
LWR 3050	18	8	50		25	12.5	M4	3.3	6	3.2	8.2						
LWR 3075	18	8	75		25	12.5	M4	3.3	6	3.2	8.2						
LWR 3100	18	8	100		25	12.5	M4	3.3	6	3.2	8.2						
LWR 3125	18	8	125		25	12.5	M4	3.3	6	3.2	8.2						
LWR 3150	18	8	150		25	12.5	M4	3.3	6	3.2	8.2						
LWR 3175	18	8	175		25	12.5	M4	3.3	6	3.2	8.2						
LWR 3200	18	8	200		25	12.5	M4	3.3	6	3.2	8.2						
LWR 3250	18	8	250		25	12.5	M4	3.3	6	3.2	8.2						
LWR 3300	18	8	300		25	12.5	M4	3.3	6	3.2	8.2						
Roller assemblies																	
LWAK 3												3	7.5	1	5	1320	1600
End pieces																	
LWERA 3			2.5	-													
Special attachment screw																	
LWGD 3																	
* Load ratings for 10 rolling elements																	

See page 82
for drawing

LWR 6

Designations	Dimensions															Load ratings*	
	A	B	L	L ₁	J	J ₁	G	G ₁	N	N ₁	A ₁	D _W	U	U ₁	t	dynamic C	static C ₀
	mm															N	
Rails																	
LWR 6100	31	15	100		50	25	M6	5.2	9.5	5.2	14						
LWR 6150	31	15	150		50	25	M6	5.2	9.5	5.2	14						
LWR 6200	31	15	200		50	25	M6	5.2	9.5	5.2	14						
LWR 6250	31	15	250		50	25	M6	5.2	9.5	5.2	14						
LWR 6300	31	15	300		50	25	M6	5.2	9.5	5.2	14						
LWR 6350	31	15	350		50	25	M6	5.2	9.5	5.2	14						
LWR 6400	31	15	400		50	25	M6	5.2	9.5	5.2	14						
Roller assemblies																	
LWAL 6												6	14.8	2.7	9	5850	6800
End pieces																	
LWERA 6			3	-													
Special attachment screw																	
LWGD 6																	
* Load ratings for 10 rolling elements																	

See page 82
for drawing

LWR 9

Designations	Dimensions														Load ratings*		
	A	B	L	L ₁	J	J ₁	G	G ₁	N	N ₁	A ₁	D _W	U	U ₁	t	dynamic C	static C ₀
	mm														N		
Rails																	
LWR 90200	44	22	200		100	50	M8	6.8	11	6.2	20						
LWR 90300	44	22	300		100	50	M8	6.8	11	6.2	20						
LWR 90400	44	22	400		100	50	M8	6.8	11	6.2	20						
LWR 90500	44	22	500		100	50	M8	6.8	11	6.2	20						
LWR 90600	44	22	600		100	50	M8	6.8	11	6.2	20						
LWR 90700	44	22	700		100	50	M8	6.8	11	6.2	20						
Roller assemblies																	
LWAL 9												9	20	4	14	17000	18300
End pieces																	
LWERA 9			4	-													
Special attachment screw																	
LWGD 9																	
* Load ratings for 10 rolling elements																	

See page 82
for drawing

LWR 12

Designations	Dimensions														Load ratings*		
	A	B	L	L ₁	J	J ₁	G	G ₁	N	N ₁	A ₁	D _W	U	U ₁	t	dynamic C	static C ₀
	mm														N		
Rails																	
LWR 120300	58	28	300		100	50	M10	8.5	14	8.2	26						
LWR 120400	58	28	400		100	50	M10	8.5	14	8.2	26						
LWR 120500	58	28	500		100	50	M10	8.5	14	8.2	26						
LWR 120600	58	28	600		100	50	M10	8.5	14	8.2	26						
Roller assemblies																	
LWAL 12												12	25	5	18	30000	30500
End pieces																	
LWERA 12			5	-													
Special attachment screw																	
LWGD 12																	
* Load ratings for 10 rolling elements																	

See page 82
for drawing

LWRE ..

LWRE rail guides are a logical development of the proven LWR rail guides.

Within the modular range system the LWRE rail guides offer an outstanding price/performance ratio.

Alongside the familiar characteristics of the LWR series, the new LWRE rail guides offer the advantages of a fivefold increase in load-carrying capacity and a doubling of the stiffness, achieved through optimised internal geometry in conjunction with larger roller diameters.

LWRE rail guides offer a greatly increased safety margin, thus a very much

smaller LWRE rail guide can be used in a given design space, maintaining the same load-carrying capacity as the LWR.

The mounting and attachment dimensions of the LWRE 3, 6, 9 rail guides conform to those of all SKF modular range rail guides presented in this catalogue.

It is recommended to make rail guides longer than 1200 mm up of sections.

LWRE rail guides are optimised with large rollers and improved internal geometry providing high load-carrying capacity and stiffness. They are available with ACS.

Each part of a LWRE rail guide system must be ordered separately, because of the large number of possible combinations of:

- 4 rail guides LWRE
- 2 crossed roller assemblies LWAKE
- 8 end pieces LWERE

LWRE .. KIT

The KIT package for the modular range is a unique service provided only by SKF.

Rails

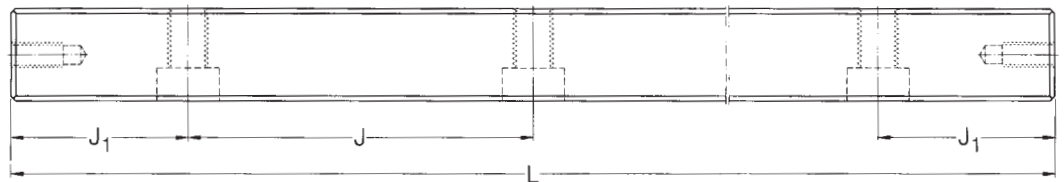
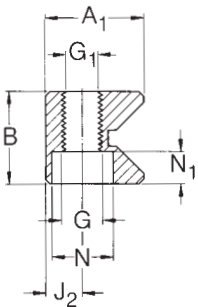
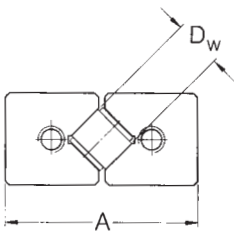

End pieces

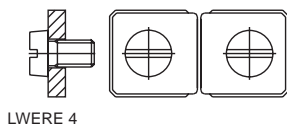
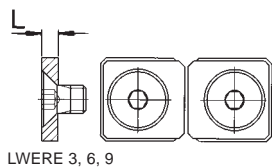

Crossed roller assemblies

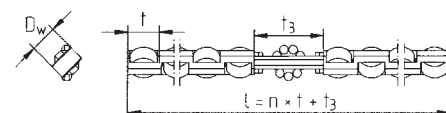
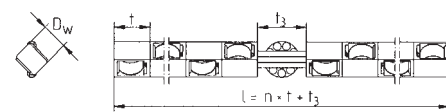
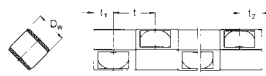

Special attachment screw

LWAKE 3, 6, 9

LWAKE 3, 6, 9 ACS

LWAKE 4

LWAKE 4 ACS

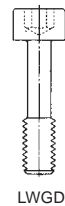

LWGD

2 Guiding systems

Precision rail guides

LWRE 3/4/6 .. KIT

- 4 rail guides LWRE
- 2 crossed roller assemblies LWAKE
- 8 end pieces LWERE

Designations	Load ratings*		Stroke		Rail designations	Cage designations
	dynamic C	static C ₀	min.	max.		
	N		mm			
LWRE 3050 KIT	4230	5100	25	33	LWRE 3050	LWAKE 3×6
LWRE 3075 KIT	5803	7650	38	50	LWRE 3075	LWAKE 3×9
LWRE 3100 KIT	7263	10200	50	67	LWRE 3100	LWAKE 3×12
LWRE 3125 KIT	8644	12750	63	83	LWRE 3125	LWAKE 3×15
LWRE 3150 KIT	9964	15300	75	100	LWRE 3150	LWAKE 3×18
LWRE 3175 KIT	11238	17850	88	117	LWRE 3175	LWAKE 3×21
LWRE 3200 KIT	12471	20400	100	133	LWRE 3200	LWAKE 3×24

*Load ratings for 10 rolling elements
Including 8 end stops LWERE 3

See page 87 for drawing

Designations	Load ratings*		Stroke		Rail designations	Cage designations
	dynamic C	static C ₀	min.	max.		
	N		mm			
LWRE 4100 KIT	17300	20800	39	67	LWRE 4100	LWAKE 4×10
LWRE 4150 KIT	23735	31200	62	100	LWRE 4150	LWAKE 4×15
LWRE 4200 KIT	28541	39520	95	133	LWRE 4200	LWAKE 4×19
LWRE 4250 KIT	34246	49920	118	167	LWRE 4250	LWAKE 4×24
LWRE 4300 KIT	38622	58240	152	200	LWRE 4300	LWAKE 4×28
LWRE 4350 KIT	43902	68640	169	233	LWRE 4350	LWAKE 4×33
LWRE 4400 KIT	49009	79040	192	267	LWRE 4400	LWAKE 4×38

* Load ratings for 10 rolling elements
Including 8 end stops LWERE 4

See page 87 for drawing

Designations	Load ratings*		Stroke		Rail designations	Cage designations
	dynamic C	static C ₀	min.	max.		
	N		mm			
LWRE 6100 KIT	25743	27300	46	67	LWRE 6100	LWAKE 6×7
LWRE 6150 KIT	34000	39000	80	100	LWRE 6150	LWAKE 6×10
LWRE 6200 KIT	44204	54600	92	133	LWRE 6200	LWAKE 6×14
LWRE 6250 KIT	51431	66300	126	167	LWRE 6250	LWAKE 6×17
LWRE 6300 KIT	58382	78000	160	200	LWRE 6300	LWAKE 6×20
LWRE 6350 KIT	67304	93600	172	233	LWRE 6350	LWAKE 6×24
LWRE 6400 KIT	73781	105300	208	267	LWRE 6400	LWAKE 6×27

* Load ratings for 10 rolling elements
Including 8 end stops LWERE 6

See page 87 for drawing

LWRE 3/4/6 .. ACS - KIT

4 rail guides LWRE ACS
2 crossed roller assemblies LWAKE
8 end pieces LWERE

See page 87 for drawing

Designations	Load ratings*		Stroke		Rail designations	Cage designations
	dynamic C	static C ₀	min.	max.		
	N		mm			
LWRE 3050 ACS-KIT	4230	5100	20	33	LWRE 3050 ACS	LWAKE 3×6 ACS
LWRE 3075 ACS-KIT	5294	6800	30	50	LWRE 3075 ACS	LWAKE 3×6 ACS
LWRE 3100 ACS-KIT	6300	8500	45	67	LWRE 3100 ACS	LWAKE 3×10 ACS
LWRE 3125 ACS-KIT	7731	11050	62	83	LWRE 3125 ACS	LWAKE 3×13 ACS
LWRE 3150 ACS-KIT	9090	13600	79	100	LWRE 3150 ACS	LWAKE 3×16 ACS
LWRE 3175 ACS-KIT	9964	15300	94	117	LWRE 3175 ACS	LWAKE 3×18 ACS
LWRE 3200 ACS-KIT	11653	18700	100	133	LWRE 3200 ACS	LWAKE 3×22 ACS

* Load ratings for 10 rolling elements
Including 8 end stops LWERE 3

2

Designations	Load ratings*		Stroke		Rail designations	Cage designations
	dynamic C	static C ₀	min.	max.		
	N		mm			
LWRE 4100 ACS-KIT	14536	16640	40	67	LWRE 4100 ACS	LWAKE 4×8 ACS
LWRE 4150 ACS-KIT	19944	24960	79	100	LWRE 4150 ACS	LWAKE 4×12 ACS
LWRE 4200 ACS-KIT	26170	35360	96	133	LWRE 4200 ACS	LWAKE 4×17 ACS
LWRE 4250 ACS-KIT	30859	43680	129	167	LWRE 4250 ACS	LWAKE 4×21 ACS
LWRE 4300 ACS-KIT	36452	54080	152	200	LWRE 4300 ACS	LWAKE 4×26 ACS
LWRE 4350 ACS-KIT	41813	64480	175	233	LWRE 4350 ACS	LWAKE 4×31 ACS
LWRE 4400 ACS-KIT	45964	72800	203	267	LWRE 4400 ACS	LWAKE 4×35 ACS

* Load ratings for 10 rolling elements
Including 8 end stops LWERE 4

See page 87 for drawing

Designations	Load ratings*		Stroke		Rail designations	Cage designations
	dynamic C	static C ₀	min.	max.		
	N		mm			
LWRE 6100 ACS-KIT	22826	23400	37	67	LWRE 6100 ACS	LWAKE 6×6 ACS
LWRE 6150 ACS-KIT	31318	35100	71	100	LWRE 6150 ACS	LWAKE 6×9 ACS
LWRE 6200 ACS-KIT	39196	46800	105	133	LWRE 6200 ACS	LWAKE 6×12 ACS
LWRE 6250 ACS-KIT	49056	62400	117	167	LWRE 6250 ACS	LWAKE 6×16 ACS
LWRE 6300 ACS-KIT	56093	74100	151	200	LWRE 6300 ACS	LWAKE 6×19 ACS
LWRE 6350 ACS-KIT	65107	89700	163	233	LWRE 6350 ACS	LWAKE 6×23 ACS
LWRE 6400 ACS-KIT	71640	101400	197	267	LWRE 6400 ACS	LWAKE 6×26 ACS

* Load ratings for 10 rolling elements
Including 8 end stops LWERE 6

See page 87 for drawing

LWRE 3

Designations	Dimensions													Load ratings*		
	A	B	L	L ₁	J	J ₁	G	G ₁	N	N ₁	A ₁	D _W	t	dynamic C	static C ₀	
	mm													N		
Rails																
LWRE 3050	18	8	50		25	12.5	M4	3.3	6	3.2	8.7					
LWRE 3075	18	8	75		25	12.5	M4	3.3	6	3.2	8.7					
LWRE 3100	18	8	100		25	12.5	M4	3.3	6	3.2	8.7					
LWRE 3125	18	8	125		25	12.5	M4	3.3	6	3.2	8.7					
LWRE 3150	18	8	150		25	12.5	M4	3.3	6	3.2	8.7					
LWRE 3175	18	8	175		25	12.5	M4	3.3	6	3.2	8.7					
LWRE 3200	18	8	200		25	12.5	M4	3.3	6	3.2	8.7					
Crossed roller assemblies																
LWAKE 3												4	6.25	6300	8500	
End pieces																
LWRE 3			2	-												
Special attachment screw																
LWGD 3																
* Load ratings for 10 rolling elements																

See page 87
for drawing

LWRE 2211

Designations	Dimensions														Load ratings*		
	A	B	L	L ₁	J	J ₁	G	G ₁	N	N ₁	A ₁	D _W	t	t ₁	t ₂	dynamic C	static C ₀
	mm														N		
Rails																	
LWRE 22110080	22	11	80		40	20	M5	4.3	7.5	4.1	11	4	6.25	2.65	3.6	6300	8500
LWRE 22110120	22	11	120		40	20	M5	4.3	7.5	4.1	11	4	6.25	2.65	3.6	6300	8500
LWRE 22110160	22	11	160		40	20	M5	4.3	7.5	4.1	11	4	6.25	2.65	3.6	6300	8500
LWRE 22110200	22	11	200		40	20	M5	4.3	7.5	4.1	11	4	6.25	2.65	3.6	6300	8500
LWRE 22110240	22	11	240		40	20	M5	4.3	7.5	4.1	11	4	6.25	2.65	3.6	6300	8500
LWRE 22110280	22	11	280		40	20	M5	4.3	7.5	4.1	11	4	6.25	2.65	3.6	6300	8500
LWRE 22110320	22	11	320		40	20	M5	4.3	7.5	4.1	11	4	6.25	2.65	3.6	6300	8500
LWRE 22110360	22	11	360		40	20	M5	4.3	7.5	4.1	11	4	6.25	2.65	3.6	6300	8500
LWRE 22110400	22	11	400		40	20	M5	4.3	7.5	4.1	11	4	6.25	2.65	3.6	6300	8500
Crossed roller assemblies																	
LWAKE 3												4	6.25			6300	8500
End pieces																	
LWRE 3			2	-													
* Load ratings for 10 rolling elements																	

See page 87
for drawing

LWRE 4

Designations	Dimensions													Load ratings*		
	A	B	L	L ₁	J	J ₁	G	G ₁	N	N ₁	A ₁	D _w	t	dynamic C	static C ₀	
	mm													N		
Rails																
LWRE 4100	25	12	100		25	12.5	M4	3.3	6	3.2	12					
LWRE 4150	25	12	150		25	12.5	M4	3.3	6	3.2	12					
LWRE 4200	25	12	200		25	12.5	M4	3.3	6	3.2	12					
LWRE 4250	25	12	250		25	12.5	M4	3.3	6	3.2	12					
LWRE 4300	25	12	300		25	12.5	M4	3.3	6	3.2	12					
LWRE 4400	25	12	400		25	12.5	M4	3.3	6	3.2	12					
Crossed roller assemblies																
LWAKE 4												6.5	8	17300	20800	
End pieces																
LWERE 4			4	-												
Special attachment screw																
LWGD 4																
* Load ratings for 10 rolling elements																

See page 87
for drawing

LWRE 6

Designations	Dimensions													Load ratings*		
	A	B	L	L ₁	J	J ₁	G	G ₁	N	N ₁	A ₁	D _w	t	dynamic C	static C ₀	
	mm													N		
Rails																
LWRE 6100	31	15	100		50	25	M6	5.2	9.5	5.2	15					
LWRE 6150	31	15	150		50	25	M6	5.2	9.5	5.2	15					
LWRE 6200	31	15	200		50	25	M6	5.2	9.5	5.2	15					
LWRE 6250	31	15	250		50	25	M6	5.2	9.5	5.2	15					
LWRE 6300	31	15	300		50	25	M6	5.2	9.5	5.2	15					
LWRE 6400	31	15	400		50	25	M6	5.2	9.5	5.2	15					
Crossed roller assemblies																
LWAKE 6												8	11	34000	39000	
End pieces																
LWERE 6			3	-												
Special attachment screw																
LWGD 6																
* Load ratings for 10 rolling elements																

See page 87
for drawing

LWRE 9

Designations	Dimensions													Load ratings*		
	A	B	L	L ₁	J	J ₁	G	G ₁	N	N ₁	A ₁	D _W	t	dynamic C	static C ₀	
	mm													N		
Rails																
LWRE 90200	44	22	200		100	50	M8	6.8	11	6.2	22					
LWRE 90300	44	22	300		100	50	M8	6.8	11	6.2	22					
LWRE 90400	44	22	400		100	50	M8	6.8	11	6.2	22					
LWRE 90500	44	22	500		100	50	M8	6.8	11	6.2	22					
LWRE 90600	44	22	600		100	50	M8	6.8	11	6.2	22					
LWRE 90700	44	22	700		100	50	M8	6.8	11	6.2	22					
Crossed roller assemblies																
LWAKE 9												12	16	78000	78000	
End pieces																
LWERE 9			3	-												
Special attachment screw																
LWGD 9																

* Load ratings for 10 rolling elements

See page 87
for drawing

LWRE 3 ACS

Designations	Dimensions													Load ratings*		
	A	B	L	L ₁	J	J ₁	G	G ₁	N	N ₁	A ₁	D _W	t	t ₃	dynamic C	static C ₀
	mm													N		
Rails																
LWRE 3050 ACS	18	8	50		25	12.5	M4	3.3	6	3.2	8.7			9		
LWRE 3075 ACS	18	8	75		25	12.5	M4	3.3	6	3.2	8.7			9		
LWRE 3100 ACS	18	8	100		25	12.5	M4	3.3	6	3.2	8.7			9		
LWRE 3125 ACS	18	8	125		25	12.5	M4	3.3	6	3.2	8.7			9		
LWRE 3150 ACS	18	8	150		25	12.5	M4	3.3	6	3.2	8.7			9		
LWRE 3175 ACS	18	8	175		25	12.5	M4	3.3	6	3.2	8.7			9		
LWRE 3200 ACS	18	8	200		25	12.5	M4	3.3	6	3.2	8.7			9		
Crossed roller assemblies																
LWAKE 3 ACS												4	6.25	6300	8500	
End pieces																
LWERE 3			2	-												
Special attachment screw																
LWGD 3																

* Load ratings for 10 rolling elements

See page 87
for drawing

LWRE 2211 ACS

Designations	Dimensions															Load ratings*	
	A	B	L	L ₁	J	J ₁	G	G ₁	N	N ₁	A ₁	D _W	t	t ₃	dynamic C	static C ₀	
	mm															N	
Rails																	
LWRE 22110080 ACS	22	11	80		40	20	M5	4.3	7.5	4.1	11				9		
LWRE 22110120 ACS	22	11	120		40	20	M5	4.3	7.5	4.1	11				9		
LWRE 22110160 ACS	22	11	160		40	20	M5	4.3	7.5	4.1	11				9		
LWRE 22110200 ACS	22	11	200		40	20	M5	4.3	7.5	4.1	11				9		
LWRE 22110240 ACS	22	11	240		40	20	M5	4.3	7.5	4.1	11				9		
LWRE 22110280 ACS	22	11	280		40	20	M5	4.3	7.5	4.1	11				9		
LWRE 22110320 ACS	22	11	320		40	20	M5	4.3	7.5	4.1	11				9		
LWRE 22110360 ACS	22	11	360		40	20	M5	4.3	7.5	4.1	11				9		
LWRE 22110400 ACS	22	11	400		40	20	M5	4.3	7.5	4.1	11				9		
Crossed roller assemblies																	
LWAKE 3 ACS												4	6.25		6300	8500	
End pieces																	
LWERE 3																	
* Load ratings for 10 rolling elements																	

See page 87
for drawing

LWRE 4 ACS

Designations	Dimensions													Load ratings*			
	A	B	L	L ₁	J	J ₁	G	G ₁	N	N ₁	A ₁	D _W	t	t ₃	dynamic C	static C ₀	
	mm													N			
Rails																	
LWRE 4100 ACS	25	12	100		25	12.5	M4	3.3	6	3.2	12				17		
LWRE 4150 ACS	25	12	150		25	12.5	M4	3.3	6	3.2	12				17		
LWRE 4200 ACS	25	12	200		25	12.5	M4	3.3	6	3.2	12				17		
LWRE 4250 ACS	25	12	250		25	12.5	M4	3.3	6	3.2	12				17		
LWRE 4300 ACS	25	12	300		25	12.5	M4	3.3	6	3.2	12				17		
LWRE 4350 ACS	25	12	350		25	12.5	M4	3.3	6	3.2	12				17		
LWRE 4400 ACS	25	12	400		25	12.5	M4	3.3	6	3.2	12				17		
Crossed roller assemblies																	
LWAKE 4 ACS												6.5	8		17300	20800	
End pieces																	
LWERE 4				4	-												
Special attachment screw																	
LWGD 4																	
* Load ratings for 10 rolling elements																	

See page 87
for drawing

LWRE 6 ACS

Designations	Dimensions														Load ratings*	
	A	B	L	L ₁	J	J ₁	G	G ₁	N	N ₁	A ₁	D _W	t	t ₃	dynamic C	static C ₀
	mm														N	
Rails																
LWRE 6100 ACS	31	15	100		50	25	M6	5.2	9.5	5.2	15				15.3	
LWRE 6150 ACS	31	15	150		50	25	M6	5.2	9.5	5.2	15				15.3	
LWRE 6200 ACS	31	15	200		50	25	M6	5.2	9.5	5.2	15				15.3	
LWRE 6250 ACS	31	15	250		50	25	M6	5.2	9.5	5.2	15				15.3	
LWRE 6300 ACS	31	15	300		50	25	M6	5.2	9.5	5.2	15				15.3	
LWRE 6400 ACS	31	15	400		50	25	M6	5.2	9.5	5.2	15				15.3	
Crossed roller assemblies																
LWAKE 6 ACS												8	11		34000	39000
End pieces																
LWERE 6			3	-												
Special attachment screw																
LWGD 6																
* Load ratings for 10 rolling elements																

See page 87
for drawing

LWRE 9 ACS

Designations	Dimensions														Load ratings*	
	A	B	L	L ₁	J	J ₁	G	G ₁	N	N ₁	A ₁	D _W	t	t ₃	dynamic C	static C ₀
	mm														N	
Rails																
LWRE 90200 ACS	44	22	200		100	50	M8	6.8	11	6.2	22				22	
LWRE 90300 ACS	44	22	300		100	50	M8	6.8	11	6.2	22				22	
LWRE 90400 ACS	44	22	400		100	50	M8	6.8	11	6.2	22				22	
LWRE 90500 ACS	44	22	500		100	50	M8	6.8	11	6.2	22				22	
LWRE 90600 ACS	44	22	600		100	50	M8	6.8	11	6.2	22				22	
LWRE 90700 ACS	44	22	700		100	50	M8	6.8	11	6.2	22				22	
Crossed roller assemblies																
LWAKE 9 ACS												12	16		78000	78000
End pieces																
LWERE 9			3	-												
Special attachment screw																
LWGD 9																
* Load ratings for 10 rolling elements																

See page 87
for drawing

LWRM .. / LWRV ..

Guiding systems with high load carrying capacity and maximum stiffness.

Needle roller assemblies for LWRM/LWRV rail guides

LWHW needle roller assemblies have aluminium cages which provide retention of the needle rollers. They are available for size 6 and 9 units.

When ordering, the appropriate cage length in mm must be stated after the cage designation, e. g: LWHW 10×225.

End pieces for LWRM/LWRV rail guides.

End pieces serve to restrict the drift of the needle roller assemblies from the loaded zone.

LWEARM and LWEARV end pieces are fitted with a plastic wiper with a sealing lip serving to reduce the risk of contamination of the raceways.

All end pieces are supplied with the necessary attachment screws.

The mounting and attachment dimensions of the LWRM/LWRV rail guides conform to those of the other SKF modular range rail guides included in this catalogue.

Because of the large number of possible combinations, all components of LWRM/LWRV rail guides must be ordered separately, e.g.:

- 2 rail guides LWRM
- 2 rail guides LWRV
- 2 needle roller assemblies LWHW
- 2 end pieces LWEARM.

Rails

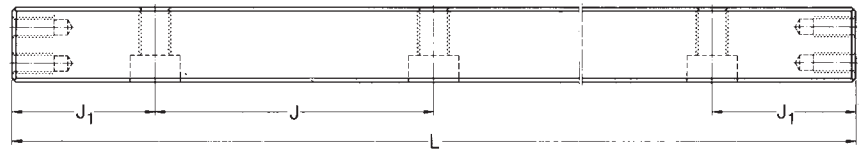
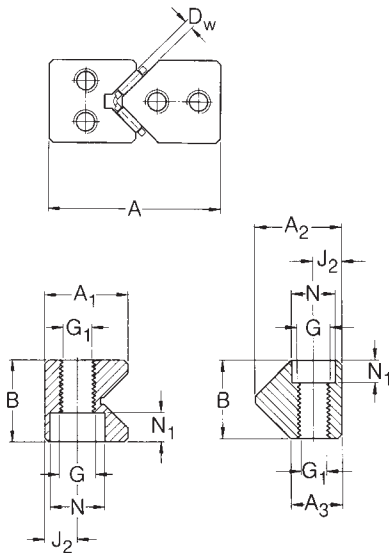

LWRM

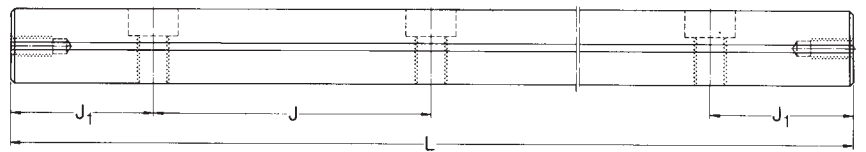

LWRV

End pieces

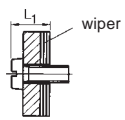

LWEARV with wiper

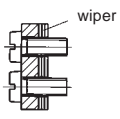

LWEARM with wiper

Rolling element assemblies

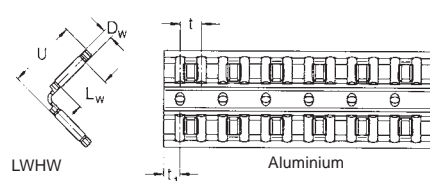

LWHW

Special attachment screw

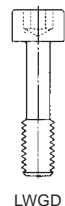

LWGD

LWRM 6 / LWRV 6

Designations	Dimensions																Load ratings*	
	A	B	L	L ₁	J	J ₁	G	G ₁	N	N ₁	A ₁	A ₂	A ₃	D _W	U	t	dynamic C	static C ₀
	mm																N	
Rails																		
LWRM/LWRV 6100	31	15	100		50	25	M6	5.2	9.5	5.2	17	18	11					
LWRM/LWRV 6150	31	15	150		50	25	M6	5.2	9.5	5.2	17	18	11					
LWRM/LWRV 6200	31	15	200		50	25	M6	5.2	9.5	5.2	17	18	11					
LWRM/LWRV 6250	31	15	250		50	25	M6	5.2	9.5	5.2	17	18	11					
LWRM/LWRV 6300	31	15	300		50	25	M6	5.2	9.5	5.2	17	18	11					
LWRM/LWRV 6400	31	15	400		50	25	M6	5.2	9.5	5.2	17	18	11					
Needle roller assemblies																		
LWHW 10														2	10	3.75	10400	25500
End pieces																		
LWEARM 6			-	6														
LWEARV 6			-	6														
Special attachment screw																		
LWGD 6																		

* For 10 needle rollers per row

See page 95
for drawing

LWRM 9 / LWRV 9

Designations	Dimensions																Load ratings*	
	A	B	L	L ₁	J	J ₁	G	G ₁	N	N ₁	A ₁	A ₂	A ₃	D _W	U	t	dynamic C	static C ₀
	mm																N	
Rails																		
LWRM/LWRV 90200	44	22	200		100	50	M8	6.8	11	6.2	23.1	27	17					
LWRM/LWRV 90300	44	22	300		100	50	M8	6.8	11	6.2	23.1	27	17					
LWRM/LWRV 90400	44	22	400		100	50	M8	6.8	11	6.2	23.1	27	17					
LWRM/LWRV 90500	44	22	500		100	50	M8	6.8	11	6.2	23.1	27	17					
Needle roller assemblies																		
LWHW 15														2	15	4.5	16300	45000
End pieces																		
LWEARM 9			-	8.3														
LWEARV 9			-	8.3														
Special attachment screw																		
LWGD 9																		

* For 10 needle rollers per row

See page 95
for drawing

LWM .. / LWV ..

These rail guides enable the design of linear guiding systems for heavy loads with maximum stiffness. The internal geometry is identical with that of the modular range rails of the LWRM/LWRV series. As the same needle roller assembly is used, the load bearing characteristics are identical. The external dimensions of the LWM/LWV rail guides, however, differ slightly from those of the LWRM/LWRV modular range dimensions.

LWM/LWV rail guides are widely used in machine tools. LWM/LWV rail guides have

as standard attachment hole type 15, i.e. through hole with countersinking.

If attachment hole type 13 is ordered, corresponding threaded inserts are supplied along with the guide.

For new designs the choice of LWRM/LWRV rail guides is recommended. These offer the advantage of being interchangeable with other rail guides of the modular range.

Needle roller assemblies for LWM/LWV rail guides

LWHW needle roller assemblies comprise an aluminium cage with needle rollers

arranged at right angles to each other. The needle rollers are retained by the cage.

End pieces for LWM/LWV rail guides

LWEAM and LWEAV end pieces are fitted with a plastic wiper with sealing lip which serves to keep the track free from dirt.

All end pieces are supplied together with attachment screws. It is recommended that rail guides longer than 1200 mm should be made up of sections. If, for design reasons, single-piece rails are required, these can be supplied to special order.

Rails

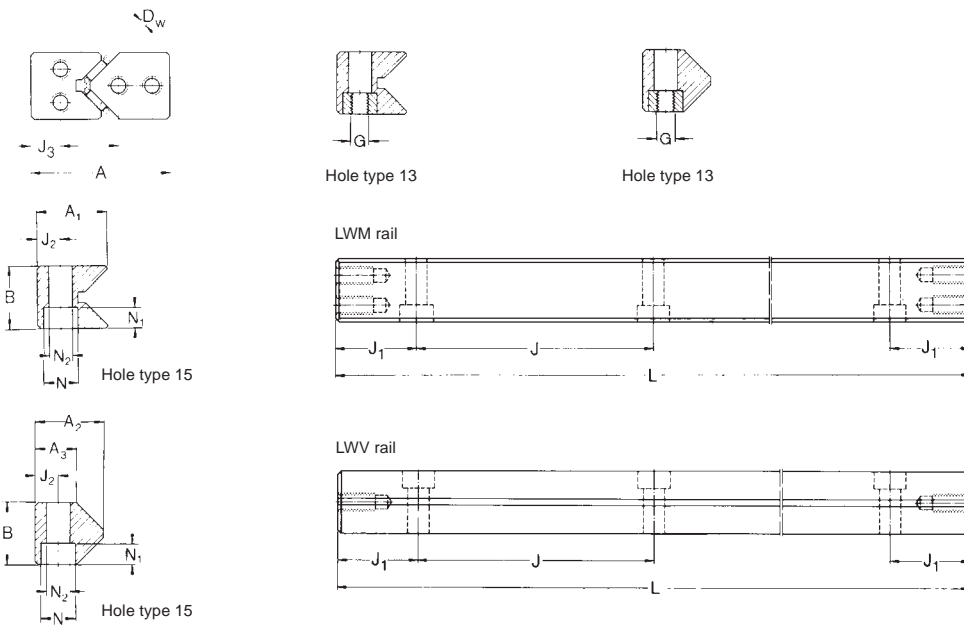

End pieces

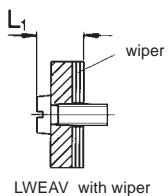
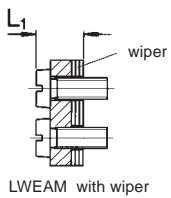

Rolling element assemblies

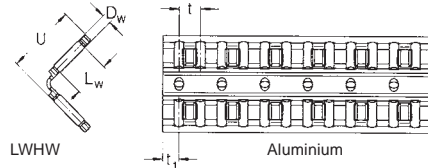

Special attachment screw

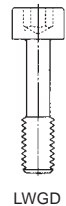

LWM 3015 /
LWV 3015

Designations	Dimensions														Load ratings*				
	A	B	L	L ₁	J ¹⁾	J _{1min} ²⁾	G	N	N ₁	N ₂	A ₁	A ₂	A ₃	D _W	U	t	dynamic C	static C ₀	
	mm																N		
Rails																			
LWM/LWV 3015100	30	15	100	40	15		M4	8.5	4.5	5.25	16	17.2	10.5						
LWM/LWV 3015150	30	15	150	40	15		M4	8.5	4.5	5.25	16	17.2	10.5						
LWM/LWV 3015200	30	15	200	40	15		M4	8.5	4.5	5.25	16	17.2	10.5						
LWM/LWV 3015300	30	15	300	40	15		M4	8.5	4.5	5.25	16	17.2	10.5						
LWM/LWV 3015400	30	15	400	40	15		M4	8.5	4.5	5.25	16	17.2	10.5						
Needle roller assemblies																			
LWHW10														2	10	3.75	10400	25500	
End pieces																			
LWEAM 3015																			
LWEAV 3015																			
Appropriate attachment screw																			
M3 DIN 84																			
* For 10 needle rollers per row																			
¹⁾ For lengths $L < J + 2 \cdot J_{1min}$, $J = 50$ mm (except for LWM/LWV 3015)																			
²⁾ J_1 depends upon the rail length and is of the same size at each end of the rail: $J_1 = (L - \Sigma J)/2$																			

See page 97
for drawing

LWM 4020 /
LWV 4020

Designations	Dimensions														Load ratings*				
	A	B	L	L ₁	J ¹⁾	J _{1min} ²⁾	G	N	N ₁	N ₂	A ₁	A ₂	A ₃	D _W	U	t	dynamic C	static C ₀	
	mm																N		
Rails																			
LWM/LWV 4020100	40	20	100	80	15		M6	11.5	6.8	7.5	22.3	22	13.5						
LWM/LWV 4020150	40	20	150	80	15		M6	11.5	6.8	7.5	22.3	22	13.5						
LWM/LWV 4020200	40	20	200	80	15		M6	11.5	6.8	7.5	22.3	22	13.5						
LWM/LWV 4020300	40	20	300	80	15		M6	11.5	6.8	7.5	22.3	22	13.5						
LWM/LWV 4020400	40	20	400	80	15		M6	11.5	6.8	7.5	22.3	22	13.5						
Needle roller assemblies																			
LWHW 15														2	15	4.5	16300	45000	
End pieces																			
LWEAM 4020																			
LWEAV 4020																			
Appropriate attachment screw																			
M5 DIN 84																			
* For 10 needle rollers per row																			
¹⁾ For lengths $L < J + 2 \cdot J_{1min}$, $J = 50$ mm (except for LWM/LWV 3015)																			
²⁾ J_1 depends upon the rail length and is of the same size at each end of the rail: $J_1 = (L - \Sigma J)/2$																			

See page 97
for drawing

LWM 5025 /
LWV 5025

Designations	Dimensions														Load ratings*			
	A	B	L	L ₁	J ¹⁾	J _{1min} ²⁾	G	N	N ₁	N ₂	A ₁	A ₂	A ₃	D _W	U	t	dynamic C	static C ₀
	mm																N	
Rails																		
LWM/LWV 50250100	50	25	100		80	20	M6	11.5	6.8	7.5	28	28	17					
LWM/LWV 50250200	50	25	200		80	20	M6	11.5	6.8	7.5	28	28	17					
LWM/LWV 50250300	50	25	300		80	20	M6	11.5	6.8	7.5	28	28	17					
LWM/LWV 50250400	50	25	400		80	20	M6	11.5	6.8	7.5	28	28	17					
LWM/LWV 50250500	50	25	500		80	20	M6	11.5	6.8	7.5	28	28	17					
Needle roller assemblies																		
LWHW 15														2	15	4.5	16300	45000
End pieces																		
LWEAM 5025					- 8.9													
LWEAV 5025					- 8.9													
Appropriate attachment screw																		
M6 DIN 84																		
* For 10 needle rollers per row																		
¹⁾ For lengths $L < J + 2 \cdot J_{1min}$, $J = 50$ mm (except for LWM/LWV 3015)																		
²⁾ J_1 depends upon the rail length and is of the same size at each end of the rail: $J_1 = (L - \Sigma J)/2$																		

See page 97
for drawing

LWM 6035 /
LWV 6035

(On request)

Designations	Dimensions														Load ratings*			
	A	B	L	L ₁	J ¹⁾	J _{1min} ²⁾	G	N	N ₁	N ₂	A ₁	A ₂	A ₃	D _W	U	t	dynamic C	static C ₀
	mm																N	
Rails																		
LWM/LWV 60350200	60	35	200		100	20	M8	15	9	10	36	36	20					
LWM/LWV 60350300	60	35	300		100	20	M8	15	9	10	36	36	20					
LWM/LWV 60350400	60	35	400		100	20	M8	15	9	10	36	36	20					
LWM/LWV 60350500	60	35	500		100	20	M8	15	9	10	36	36	20					
LWM/LWV 60350600	60	35	600		100	20	M8	15	9	10	36	36	20					
LWM/LWV 60350700	60	35	700		100	20	M8	15	9	10	36	36	20					
LWM/LWV 60350800	60	35	800		100	20	M8	15	9	10	36	36	20					
LWM/LWV 60350900	60	35	900		100	20	M8	15	9	10	36	36	20					
LWM/LWV 60351000	60	35	1000		100	20	M8	15	9	10	36	36	20					
Needle roller assemblies																		
LWHW 20														2.5	20	5.5	32000	88000
End pieces																		
LWEAM 6035					- 8.9													
LWEAV 6035					- 8.9													
Appropriate attachment screw																		
M6 DIN 84																		
* For 10 needle rollers per row																		
¹⁾ For lengths $L < J + 2 \cdot J_{1min}$, $J = 50$ mm (except for LWM/LWV 3015)																		
²⁾ J_1 depends upon the rail length and is of the same size at each end of the rail: $J_1 = (L - \Sigma J)/2$																		

See page 97
for drawing

2 Guiding systems
Precision rail guides

**LWM 7040 /
LWV 7040**

(On request)

Designations	Dimensions													Load ratings*							
	A	B	L	L ₁	J ¹⁾	J _{1min} ²⁾	G	N	N ₁	N ₂	A ₁	A ₂	A ₃	D _W	U	t	C	C ₀			
	mm																N				
Rails																					
LWM/LWV 70400200	70	40	200	100	20	M10	18.5	11	12.5	40	42	24									
LWM/LWV 70400300	70	40	300	100	20	M10	18.5	11	12.5	40	42	24									
LWM/LWV 70400400	70	40	400	100	20	M10	18.5	11	12.5	40	42	24									
LWM/LWV 70400500	70	40	500	100	20	M10	18.5	11	12.5	40	42	24									
LWM/LWV 70400600	70	40	600	100	20	M10	18.5	11	12.5	40	42	24									
LWM/LWV 70400700	70	40	700	100	20	M10	18.5	11	12.5	40	42	24									
LWM/LWV 70400800	70	40	800	100	20	M10	18.5	11	12.5	40	42	24									
LWM/LWV 70400900	70	40	900	100	20	M10	18.5	11	12.5	40	42	24									
LWM/LWV 70401000	70	40	1000	100	20	M10	18.5	11	12.5	40	42	24									
Needle roller assemblies																					
LWHW 25																	3	25	6	52000	143000
End pieces																					
LWEAM 7040																					
LWEAV 7040																					
Appropriate attachment screw																					
M6 DIN 84																					
* For 10 needle rollers per row																					
1) For lengths $L < J + 2 \cdot J_{1min}$, $J = 50$ mm (except for LWM/LWV 3015)																					
2) J_1 depends upon the rail length and is of the same size at each end of the rail: $J_1 = (L - \Sigma J)/2$																					

See page 97
for drawing

**LWM 8050 /
LWV 8050**

(On request)

Designations	Dimensions													Load ratings*							
	A	B	L	L ₁	J ¹⁾	J _{1min} ²⁾	G	N	N ₁	N ₂	A ₁	A ₂	A ₃	D _W	U	t	C	C ₀			
	mm																N				
Rails																					
LWM/LWV 80500200	80	50	200	100	20	M12	20	13	14	45	48.5	26									
LWM/LWV 80500300	80	50	300	100	20	M12	20	13	14	45	48.5	26									
LWM/LWV 80500400	80	50	400	100	20	M12	20	13	14	45	48.5	26									
LWM/LWV 80500500	80	50	500	100	20	M12	20	13	14	45	48.5	26									
LWM/LWV 80500600	80	50	600	100	20	M12	20	13	14	45	48.5	26									
LWM/LWV 80500700	80	50	700	100	20	M12	20	13	14	45	48.5	26									
LWM/LWV 80500800	80	50	800	100	20	M12	20	13	14	45	48.5	26									
LWM/LWV 80500900	80	50	900	100	20	M12	20	13	14	45	48.5	26									
LWM/LWV 80501000	80	50	1000	100	20	M12	20	13	14	45	48.5	26									
Needle roller assemblies																					
LWHW 30																	3.5	30	7	76500	212000
End pieces																					
LWEAM 8050																					
LWEAV 8050																					
Appropriate attachment screw																					
M6 DIN 84																					
* For 10 needle rollers per row																					
1) For lengths $L < J + 2 \cdot J_{1min}$, $J = 50$ mm (except for LWM/LWV 3015)																					
2) J_1 depends upon the rail length and is of the same size at each end of the rail: $J_1 = (L - \Sigma J)/2$																					

See page 97
for drawing

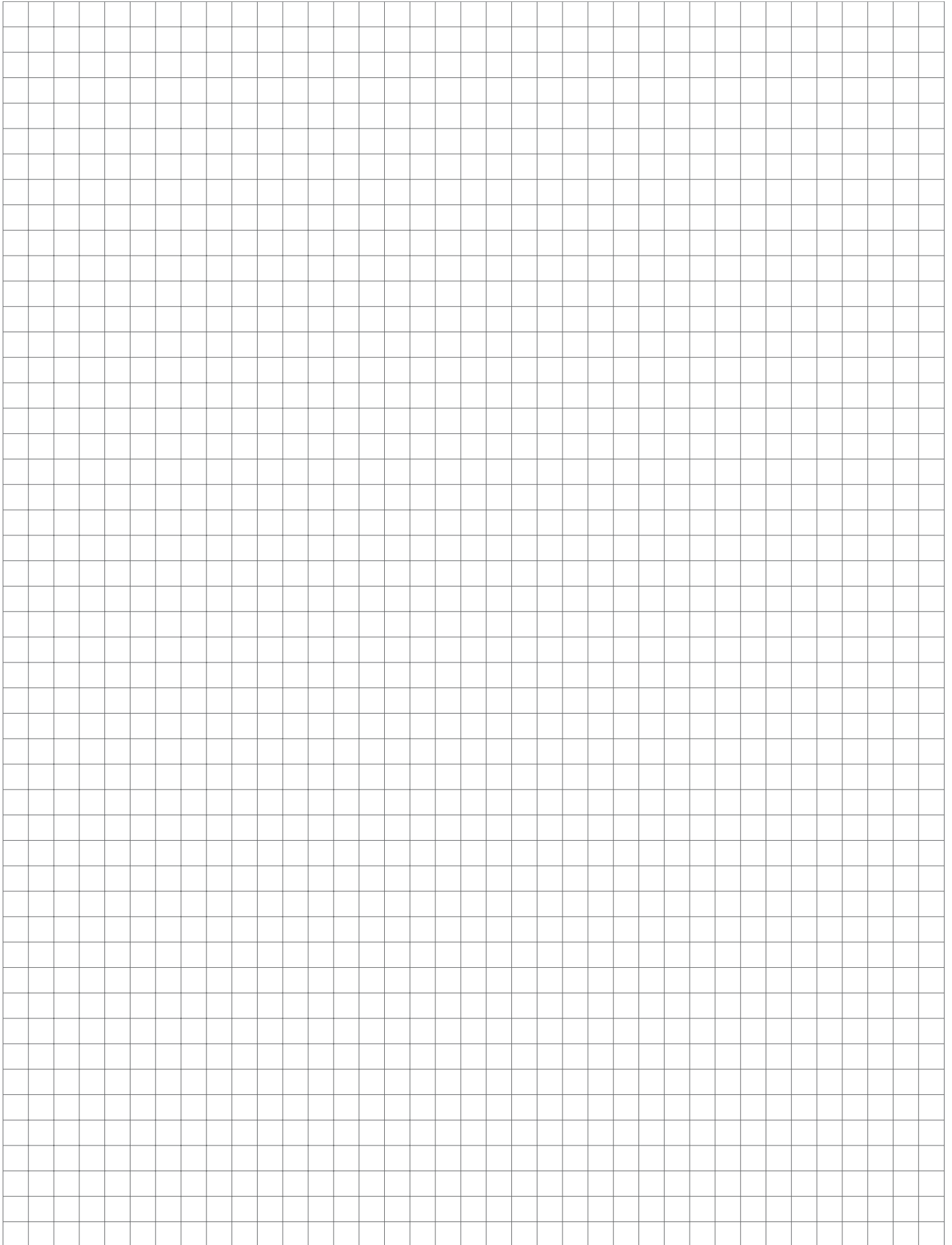



Some things are made to withstand the test of time.



The thread of a cobweb is proportionally more resistant than any material ever invented by man - even a steel cable.

Here we see just one of the wonders of nature which have provided SKF with the inspiration to develop products which will last for many years to come.

Screws, guidance systems and many other components bearing the name of SKF are made from stainless steel and are designed to withstand a corrosive environment, at the same time guaranteeing the highest quality of performance with long-term reliability for all your applications.

With SKF technology lasts.

Linear motion from SKF
www.linearmotion.skf.com



Driving systems

Ball and roller screw

SKF ball & roller screw assemblies are high-quality products, suitable for a wide range of applications where precision driving systems are needed (→ figures 1 and 2).

The high efficiency screw affords the opportunity to displace loads by transforming rotary action into linear motion. The high efficiency screw has rolling elements, balls or rollers, between the nut and the screw shaft.

In all types of ball screws, the load is transmitted from the screw shaft to the nut through each ball: several recirculating systems are available. To improve positioning accuracy, backlash can be reduced or eliminated (→ figure 3).

Two non-competing designs to cover requirements beyond ball screw limitations. Load transfer from the nut to the screw shaft through a number of threaded or grooved rollers: resulting in a large number of strong contact points (→ figure 4).

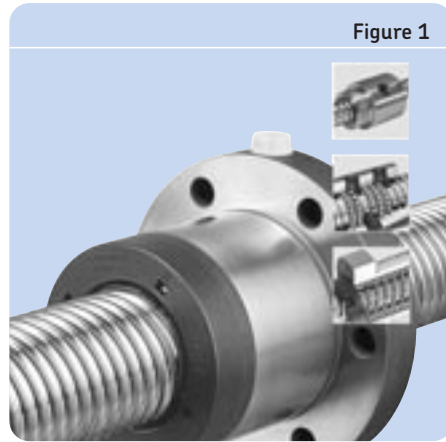

Figure 1

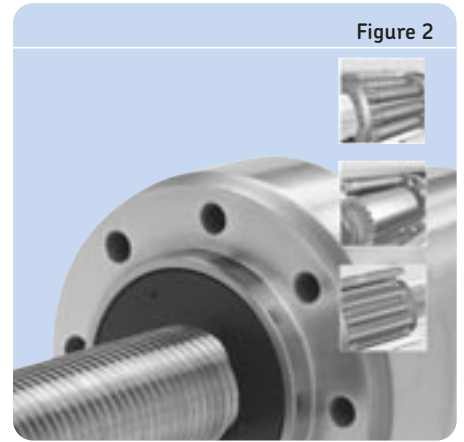

Figure 2

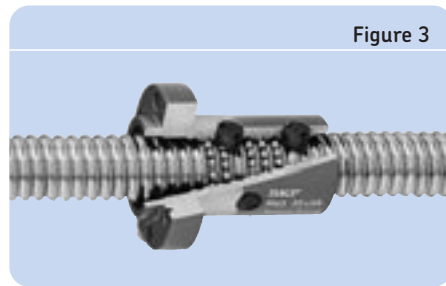

Figure 3

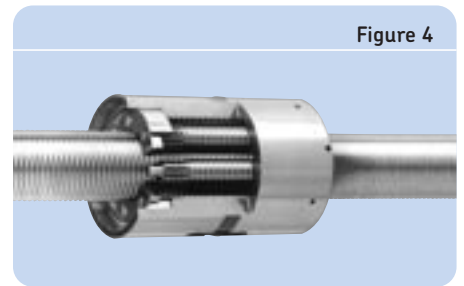

Figure 4

Operating precision (→ Table 1)

Comparison of the different positioning components and systems.

NB:

In addition to this catalogue we have all product brochures available as pdf document on the internet.

www.linearmotion.skf.com/doc

Operating precision (µm)	Guiding systems	Driving systems	Actuation systems	Positioning systems
0.1 - 1	Precision rail guides	Roller screws		
1 - 10				
10 - 100	Linear ball bearings	Ball screws		Standard drives or linear motors with all guiding systems
100 - 1000	Profile rail guides		Electro-mechanical actuators	
	Standard slides	Linear motors		
	Cam roller guides			

How to orientate your choice

In our wide range, you are sure to find the product which fits exactly your requirements:

- The miniature ball screws (→ **figure 5**), either with ball recirculation by integrated tube or with inserts, are very compact. Backdriving makes them highly efficient.
- The large ball screws (→ **figure 6**) enable you to select the right level of requirement: simple transport screws, very fast screws with long lead, or preloaded screws for more precision.
- Ground ball screws for more rigidity and precision (→ **figure 7**)
- Roller screws (→ **figure 8**) which are far beyond the limits of any ball screws as for heavy loads, ultimate precision and rigidity, high speed and acceleration and very difficult environments.

Table 2 will guide you in your first approach.

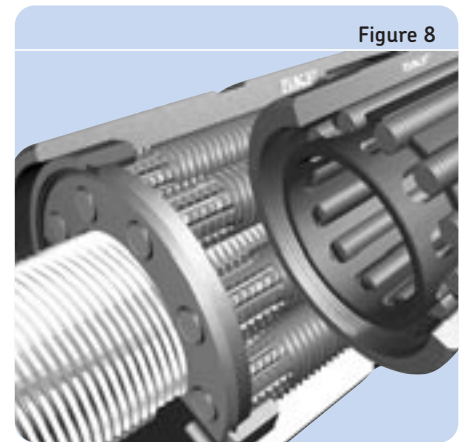
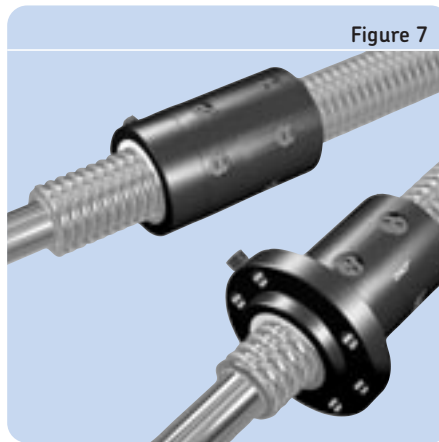
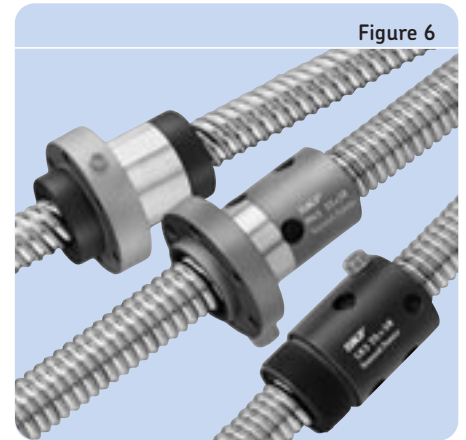
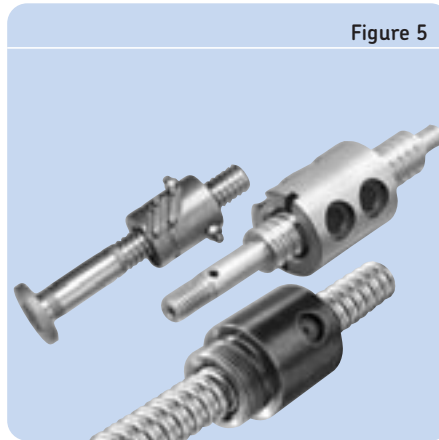



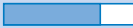
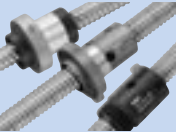



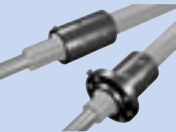











Table 2					
Type	Details	Basic dynamic load rating	Precision Ep (μ) on 300 mm	High duty cycles	Adverse environment (Spec. steel, pollution)
	SD/BD/SH Diameter Ø 6 to 16 mm	 Up to 7.6 kN	 G9 (130 μ) to G5 (23 μ)		 good
	SX/BX, SN/BN/PN SND/BND/PND SL/BL, SLD/BLD Din standard Ø 16 to 63 mm	 Up to 95 kN	 G9 (130 μ) to G5 (23 μ)		 satisfactory
	PGFJ, PGFL, PGFE, PGCL Ø 16 to 125 mm	 Up to 270 kN	 G5 (23 μ) to G1 (6 μ)		 satisfactory
	SRC, SRF, TRK/PRK, SVC, PVK Ø 8 to 210 mm	 Up to 2235 kN	 G5 (23 μ) to G1 (6 μ)		 exceptional

Ball screws

Rolled ball screws

(→ figures 9, 10, 11 and 12).

SKF ball screw assemblies are high-quality products, suitable for a wide range of applications where precision driving systems are needed.

SKF rolled thread ball screws are available in four designs to cover most requirements.

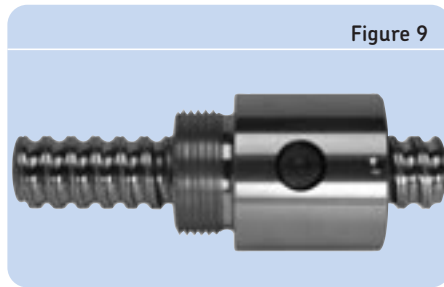

Figure 9



Figure 10

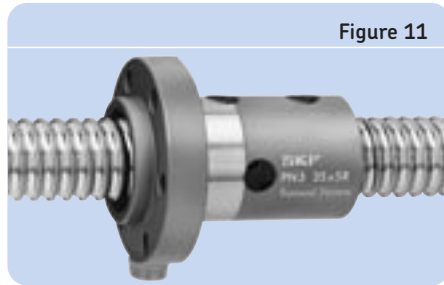

Figure 11

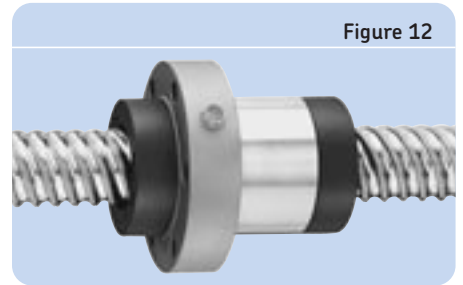

Figure 12

Complete assemblies

For reduced quantities and for all types of nuts, SKF provides complete assemblies with customised screw shaft.

A complete range of accessories is available and can be delivered completely assembled. Just ask when ordering (→ figure 13).

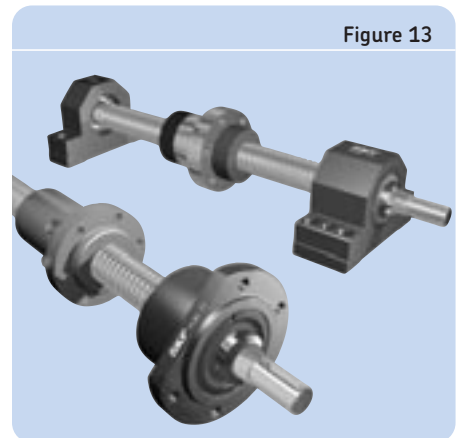

Figure 13

Table 3				
Diameters	Leads	Nut types	Precision classes	Accessories
From 6 to 63 mm	From 2 to 50 mm	Cylindrical and flanged with axial play, backlash elimination or preload, SKF & DIN standards	G5 - G7 - G9	For screw shafts and nuts

3 Driving systems

Ball screws

Ordering key

--	--	--	--	--	--	--	--	--	--	--

Nut type:

- Miniature screw, axial play, internal recirculation nut. . . . SD
- Miniature screw, backlash elimination
by oversize balls BD
- Miniature screw, axial play, recirculation
by integrated tube. SH
- Universal screw, axial play. SX
- Universal screw, backlash elimination
by oversize balls BX
- Precision screw, axial play SN
- Precision screw, backlash elimination by oversize
balls BN
- Precision screw, axial play, DIN nut SND
- Precision screw, backlash elimination by oversize
balls, DIN nut. BND
- Precision screw, with optimal rigidity PN
- Precision screw, with optimal rigidity, DIN nut. PND
- Long lead screw, axial play SL
- Long lead screw, axial play, DIN nut. SLD
- Long lead screw, backlash elimination by oversize
balls. BL
- Long lead screw, backlash elimination by oversize
balls, DIN nut BLD
- Rotating nut with axial play. SLT
- Rotating nut with backlash elimination TLT

Nominal diameter × Lead [mm]

Hand:

- Right. R
- Left (on request). L

Threaded length / Total length [mm]

Lead precision:

- G9, G7, G5

Nut orientation:

- Threaded side or flange of nut towards shorter (S) or longer (L) machined end of shaft.
- In case of same end machining (-)

Machined end combination:

See page [114-117](#)

Required lengths for AA - SA (both sides):

See page [114](#). **/**

Wipers:

- With wipers WPR
- Without wipers NOWPR
- Safety ring (for SH - SD only) RING

Example: **PND** **32×5** **R** **330** / **445** **G7** **L** - **SA** **+K** **25** / **20** **NOWPR**

SD/BD - Miniature ball screws

Ball recirculation in composite inserts,
threaded end for easy mounting.

SD: axial play

BD: backlash elimination by oversize balls

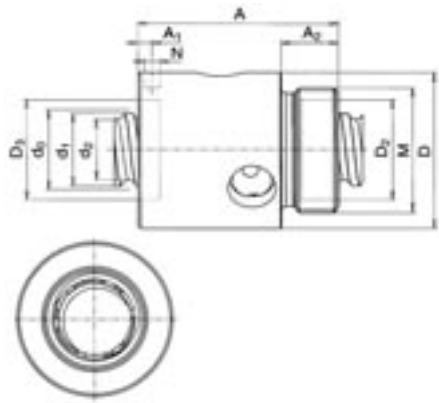

Designations	Dimensions									Lead Ph	Basic load ratings	
	d ₀	d ₁	d ₂	L Max	A	A ₂	D h10	M 6g	C _a		C _{oa}	
mm											kN	
SD/BD 8×2.5 R	8	7.6	6.3	1050	23.5	7.5	17.5	M15×1	2.5	2.2	2.6	
SD/BD 10×2 R	10	9.5	8.3	1050	22	7.5	19.5	M17×1	2	2.5	3.5	
SD/BD 10×4 R	10	8.9	7.4	1050	22	8.0	21.0	M18×1	4	4.5	5.4	
SD/BD 12×2 R	12	11.2	9.8	2100	20	8.0	20.0	M18×1	2	2.9	4.6	
SD/BD 12×4 R	12	11.3	9.4	2100	34	10.0	25.5	M20×1	4	5.0	6.5	
SD/BD 12×5 R	12	11.8	9.3	2100	36	10	23.0	M20×1	5	4.2	5.3	
SD/BD 14×4 R	14	13.7	11.9	2100	30	8	27.0	M22×1.5	4	6.0	9.0	
SD/BD 16×2 R	16	15.5	14.3	2100	27	12.0	29.5	M25×1.5	2	3.3	6.2	
SD/BD 16×5 R	16	15.2	12.7	2100	42	12.0	32.5	M26×1.5	5	7.6	10.5	

SH - Miniature ball screws

Ball recirculation in tube inside the nut,
threaded end for easy mounting

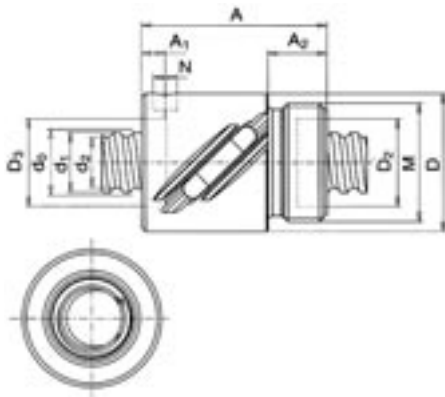

Designations	Dimensions									Lead Ph	Basic load ratings	
	d ₀	d ₁	d ₂	L Max	A	A ₂	D h10	M 6g	C _a		C _{oa}	
mm											kN	
SH 6×2 R	6	6	4.7	1050	20	7.5	16.5	M14×1	2	1.2	1.5	
SH 10×3 R	10	9.9	7.9	1050	29	9.0	21	M18×1	3	2.3	3.5	
SH 12.7×12.7 R	12.7	13.0	10.2	2100	50	12.0	29.5	M25×1.5	12.7	5.3	9.0	

Symbols = see page 151

3 Driving systems

Ball screws

SX/BX - Universal ball screws

Ball recirculation in composite inserts, threaded end for easy mounting, accessories see **pages 109 and 120-121**. Steel inserts optional.

SX: axial play

BX: backlash elimination by oversize balls

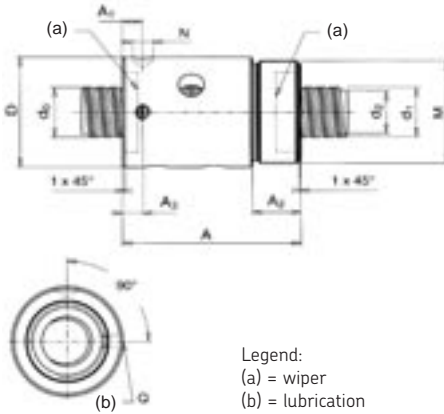

Designations	Dimensions								Lead P_h	Basic load ratings	
	d_0	d_1	d_2	L Max	A	A_2	D js13	M 6g		dynamic C_a	static C_{0a}
mm									kN		
SX/BX 20×5 R	20	19.4	16.7	5000	54	14	38	M35×1.5	5	14.5	24.4
SX/BX 25×5 R	25	24.6	21.7	5000	69	19	43	M40×1.5	5	19.4	37.8
SX/BX 25×10 R	25	24.6	20.5	5000	87	19	43	M40×1.5	10	25.8	43.7
SX/BX 32×5 R	32	31.6	28.7	6000	69	19	52	M48×1.5	5	22.1	50.5
SX/BX 32×10 R	32	32.0	27.8	6000	95	19	54	M48×1.5	10	28.9	55.7
SX/BX 40×5 R	40	39.6	36.7	6000	69	19	60	M56×1.5	5	24.1	63.2
SX/BX 40×10 R	40	39.4	34.0	6000	110	24	65	M60×2	10	63.6	127.1
SX/BX 50×10 R	50	49.7	44.0	6000	135	29	78	M72×2	10	81.9	189.1
SX/BX 63×10 R	63	62.8	57.0	6000	135	29	93	M85×2	10	91.7	243.5

FHRF

Round flanges (for SX nuts only)

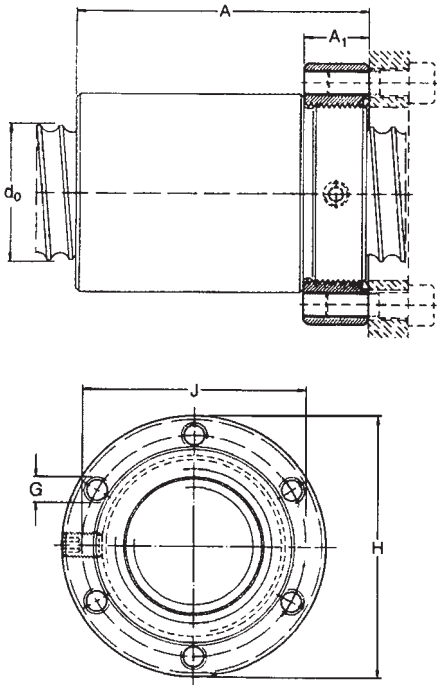

Designations

Dimensions

d_0 P_h A A_1 J H
h14 h14 JS12 h12

mm

FHRF 20	20	5	55	15	44	52
FHRF 25	25	5	70	20	50	60
FHRF 25	25	10	88	20	50	60
FHRF 32	32	5	70	20	59	69
FHRF 32	32	10	96	20	59	69
FHRF 40×5	40	5	70	20	69	82
FHRF 40×10	40	10	111	25	76	92
FHRF 50	50	10	136	30	91	110
FHRF 63	63	10	136	30	106	125

FHSF

Square flanges (for SX nuts only)

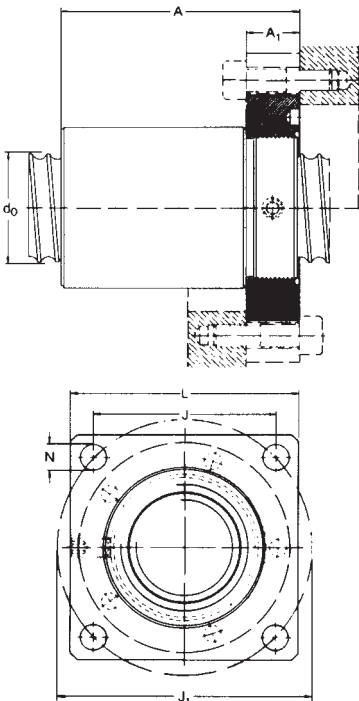

Designations

Dimensions

d_0 P_h A A_1 J H
h14 h14 JS12 h12

mm

FHSF 20	20	5	55	15	45	60
FHSF 25	25	5	70	20	52	70
FHSF 25	25	10	88	20	52	70
FHSF 32	32	5	70	20	60	80
FHSF 32	32	10	96	20	60	80
FHSF 40×5	40	5	70	20	70	90
FHSF 40×10	40	10	111	25	78	100
FHSF 50	50	10	136	30	94	120
FHSF 63	63	10	136	30	104	130

Symbols = see page 151

3 Driving systems

Ball screws

SN/BN - Precision ball screws

Ball recirculation in composite inserts. Steel insert optional.

SN: axial play

BN: backlash elimination by oversize balls.

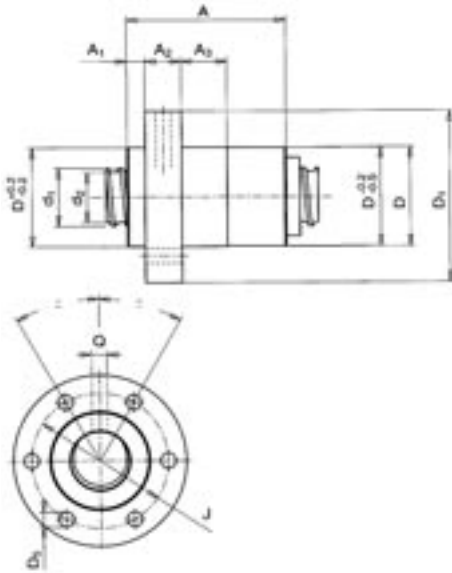

Designations	Dimensions										Lead P _h	Basic load ratings	
	d ₀	d ₁	d ₂	L Max	A	A ₂	D	D ₁	J	G		C _a	C _{0a}
	mm											kN	
SN/BN 16×5 R	16	15.2	12.7	2100	50.5	10	28	48	38	M5	5	8.1	12.4
SN/BN 20×5 R	20	19.4	16.7	5000	52.5	12	33	57	45	M6	5	11.7	18.3
SN/BN 25×5 R	25	24.6	21.7	5000	52.5	12	38	62	50	M6	5	13.0	22.7
SN/BN 25×10 R	25	24.6	20.5	5000	85.0	12	43	67	55	M6	10	25.8	43.7
SN/BN 32×5 R	32	31.6	28.7	6000	57.5	12	45	70	58	M6	5	19.1	40.4
SN/BN 32×10 R	32	32.0	27.8	6000	79.0	16	54	87	70	M8	10	22.6	41.8
SN/BN 40×5 R	40	39.6	36.7	6000	64.5	14	53	80	68	M6	5	25.4	63.2
SN/BN 40×10 R	40	39.4	34.0	6000	99.0	16	63	95	78	M8	10	63.6	127.1
SN/BN 50×10 R	50	49.7	44.0	6000	99.0	16	72	110	90	M10	10	70.6	157.6
SN/BN 63×10 R	63	62.8	57.0	6000	103.0	20	85	125	105	M10	10	78.4	202.9

SND/BND - Precision ball screws

Ball recirculation in composite inserts, Din standard. Steel insert optional.

SND: axial play

BND: backlash elimination by oversize balls.

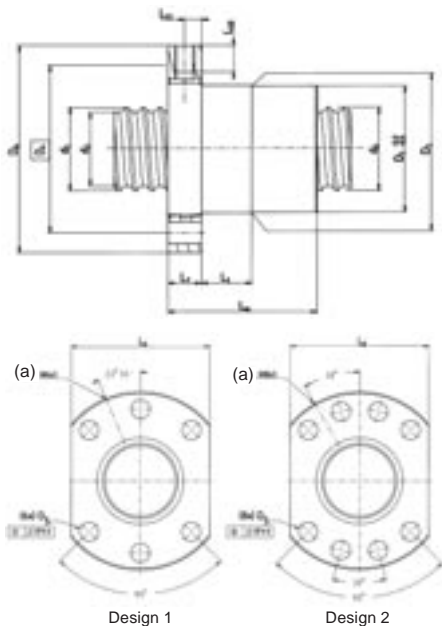

Designations	Dimensions					Lead P _h	Basic load ratings		Design static C _{0a}	
	d ₀	d ₁	d ₂	L Max	D ₁ g6		D ₄	C _a		C _{0a}
	mm						kN			
SND/BND 16×5 R	16	15.2	12.7	2100	28	38	5	8.1	12.4	1
SND/BND 20×5 R	20	19.4	16.7	5000	36	47	5	11.7	18.3	1
SND/BND 25×5 R	25	24.6	21.7	5000	40	51	5	13.0	22.7	1
SND/BND 25×10 R	25	24.6	20.5	5000	40	51	10	25.8	43.7	1
SND/BND 32×5 R	32	31.6	28.7	6000	50	65	5	19.1	40.4	1
SND/BND 32×10 R	32	32.0	27.8	6000	50	65	10	22.6	41.8	1
SND/BND 40×5 R	40	39.6	36.7	6000	63	78	5	25.4	63.2	2
SND/BND 40×10 R	40	39.4	34.0	6000	63	78	10	63.6	127.1	2
SND/BND 50×10 R	50	49.7	44.0	6000	75	93	10	70.6	157.6	2
SND/BND 63×10 R	63	62.8	57.0	6000	90	108	10	78.4	202.9	2

Legend:

(a) = lubrication hole

Symbols = see page 151

PN - Precision ball screws

Ball recirculation in composite inserts, preloaded for optimal rigidity. Steel inserts optional

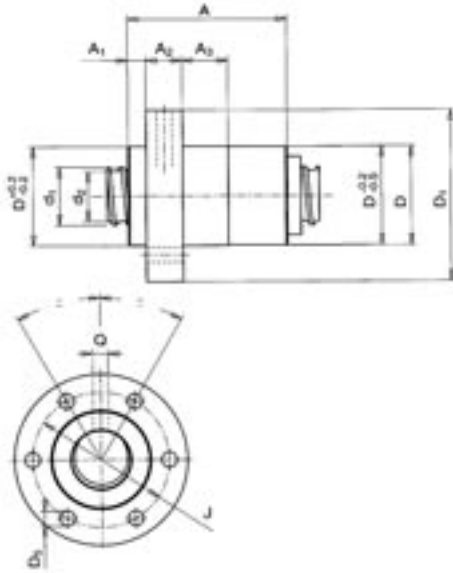

Designations	Dimensions										Lead P _h	Basic load ratings	
	d ₀	d ₁	d ₂	L Max	A	A ₂	D	D ₁	J	G		C _a	C _{0a}
	mm											kN	
PN 16×5 R	16	15.2	12.7	2100	52	10	28	48	38	M5	5	5.7	8.3
PN 20×5 R	20	19.4	16.7	5000	58	12	33	57	45	M6	5	8.2	12.2
PN 25×5 R	25	24.6	21.7	5000	70	12	38	62	50	M6	5	13.0	22.7
PN 25×10 R	25	24.6	20.5	5000	85	12	43	67	55	M6	10	14.2	21.8
PN 32×5 R	32	31.6	28.7	6000	80	12	45	70	58	M6	5	19.1	40.4
PN 32×10 R	32	32	27.8	6000	113	16	54	87	70	M8	10	22.6	41.8
PN 40×5 R	40	39.6	36.7	6000	94	14	53	80	68	M6	5	25.4	63.2
PN 40×10 R	40	39.4	34.0	6000	134	16	63	95	78	M8	10	52.5	101.7
PN 50×10 R	50	49.7	44.0	6000	157	16	72	110	90	M10	10	70.6	157.6
PN 63×10 R	63	62.8	57.0	6000	161	20	85	125	105	M10	10	78.4	202.9

3

PND - Precision ball screws

Ball recirculation in composite inserts, nut to DIN standard, preloaded for optimal rigidity. Steel inserts optional

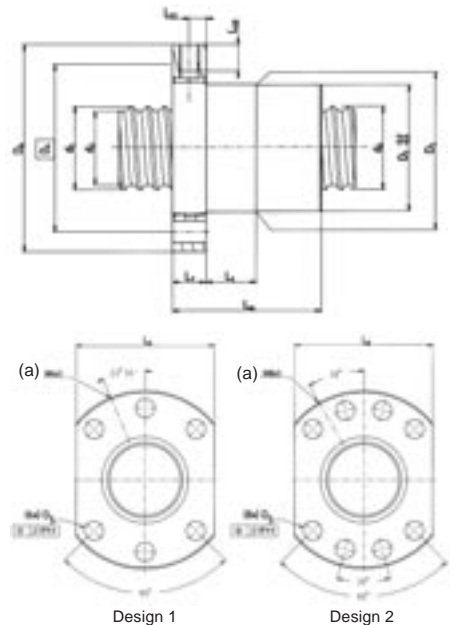

Designations	Dimensions								Lead P _h	Basic load ratings		Design
	d ₀	L Max	D ₁	D ₄	D ₅	D ₆	L ₈	L _{tn}		C _a	C _{0a}	
	mm									kN		
PND 16×5 R	16	2100	28	38	5.5	48	40	50	5	5.7	8.3	1
PND 20×5 R	20	5000	36	47	6.6	58	44	50	5	8.2	12.2	1
PND 25×5 R	25	5000	40	51	6.6	62	48	62	5	13.0	22.7	1
PND 25×10 R	25	5000	40	51	6.6	62	48	75	10	14.2	21.8	1
PND 32×5 R	32	6000	50	65	9.0	80	62	74	5	19.1	40.4	1
PND 32×10 R	32	6000	50	65	9.0	80	62	102	10	22.6	41.8	1
PND 40×5 R	40	6000	63	78	9.0	93	70	88	5	25.4	63.2	2
PND 40×10 R	40	6000	63	78	9.0	93	70	130	10	52.5	101.7	2
PND 50×10 R	50	6000	75	93	11.0	110	85	155	10	70.6	157.6	2
PND 63×10 R	63	6000	90	108	11.0	125	95	157	10	78.4	202.9	2

Legend:

(a) = lubrication hole

Symbols = see page 151

3 Driving systems

Ball screws

SL/BL - Long lead ball screws

Ball recirculation through the face.

SL: axial play

BL: backlash elimination by oversize balls.

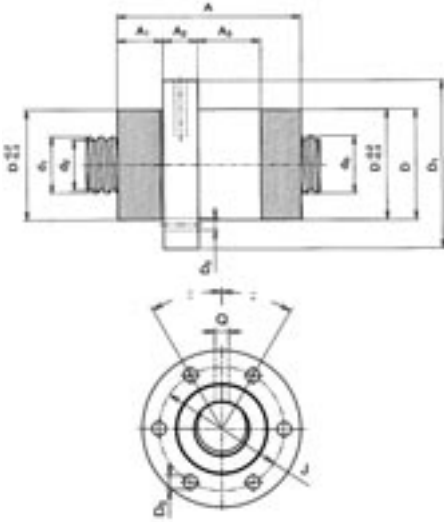

Designations	Dimensions										Lead Ph	Basic load ratings		
	d ₀	d ₁	d ₂	L Max	A	A ₂	D g9	D ₁	J js12	G 6×		C _a	C _{0a}	static
mm													kN	
SL/BL 25×20 R	25	24.3	21.7	5000	66.4	15	48	73	60	M6	20	23.0	51.6	
SL/BL 25×25 R	25	24.4	21.5	5000	77.9	15	48	73	60	M6	25	22.6	51.0	
SL/BL 32×20 R	32	30.0	27.5	6000	66.4	15	56	80	68	M6	20	25.7	65.3	
SL/BL 32×32 R	32	31.1	28.4	6000	80.3	15	56	80	68	M8	32	26.0	68.3	
SL/BL 32×40 R	32	29.6	26.9	6000	55.0	15	53*	80	68	M6	40	15.7	38.6	
SL/BL 40×20 R	40	37.7	35.2	6000	86.8	15	63	95	78	M8	20	41.8	129.4	
SL/BL 40×40 R	40	38.3	34.2	6000	110.3	25	72	110	90	M10	40	53.3	133.8	
SL/BL 50×50 R	50	49.1	43.5	6000	134.0	25	85	125	105	M10	50	94.8	238.2	

* Tolerance g6

SLD/BLD - Long lead ball screws

Ball recirculation through the face, nut to DIN standard.

SLD: axial play

BLD: backlash elimination by oversize balls

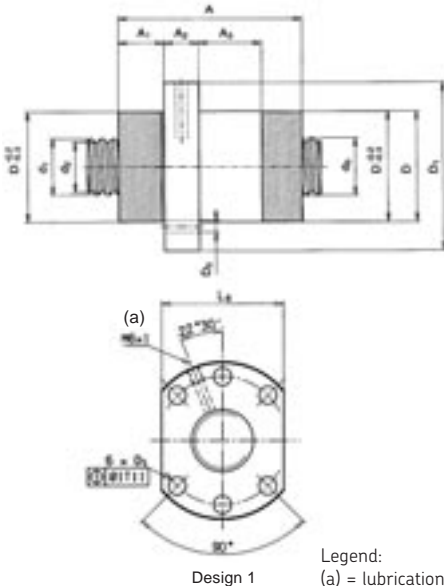

Designations	Dimensions										Lead Ph	Basic load ratings		Design ratings
	d ₀	d ₁	d ₂	L Max	A	A ₂	D g6	D ₁	J js12	G 6×		C _a	C _{0a}	
mm													kN	
SLD/BLD 32×32 R	32	31.1	28.4	6000	80.3	15	50	80	65	M8	32	26.0	68.3	1

Symbols = see page 151



3 Driving systems

Ball screws

Rotating nut

The nut rotates inside bearings and moves along the fixed long lead screw shaft.

The drive motor moves with the nut, so inertia and critical speed problems, associated with a long rotating shaft, are minimised (→ figures 14 and 15).

Two versions available:

SLT: rotating nut using ball screw with axial play

BLT: rotating nut using ball screw with backlash elimination.

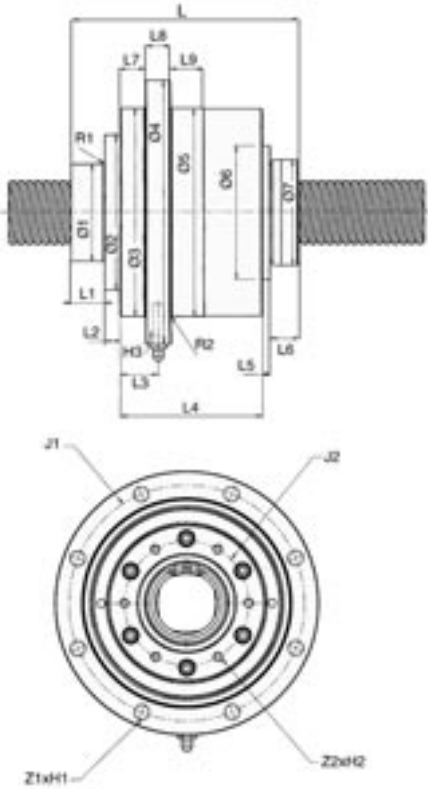

Size	Ball screw capacities		Bearing axial capacities	
	dynamic C_a	static C_{oa}	dynamic C_a	static C_{oa}
	kN			
25 × 20	39.5	96.6	61.8	56.0
25 × 25	33.5	80.5	61.8	56.0
32 × 20	49.8	141.2	78.0	76.5
32 × 32	32.1	87.3	78.0	76.5
32 × 40	30.0	81.7	78.0	76.5
40 × 20	54.7	176.7	93.6	91.5
40 × 40	53.3	133.8	114.0	118.0
50 × 50	94.8	238.2	156.0	166.0

Rotating nut inertia

Size	Inertia Pulley support	Mass of rotating nut
	kgmm ²	kg
25 × 20	1012	4.5
25 × 25	1023	4.6
32 × 20	1935	7.2
32 × 32	1919	7.1
32 × 40	1949	7.1
40 × 20	3095	7.5
40 × 40	3784	8.4
50 × 50	11482	15.5

Rotating nut capacities

Size	Max transmissible torque	Max transmissible axial load
	Nm	kN
25 × 20	180	68.3
25 × 25	180	68.3
32 × 20	209	107.0
32 × 32	209	87.3
32 × 40	209	81.7
40 × 20	240	116.0
40 × 40	246	93.3
50 × 50	803	162.0

Figure 14

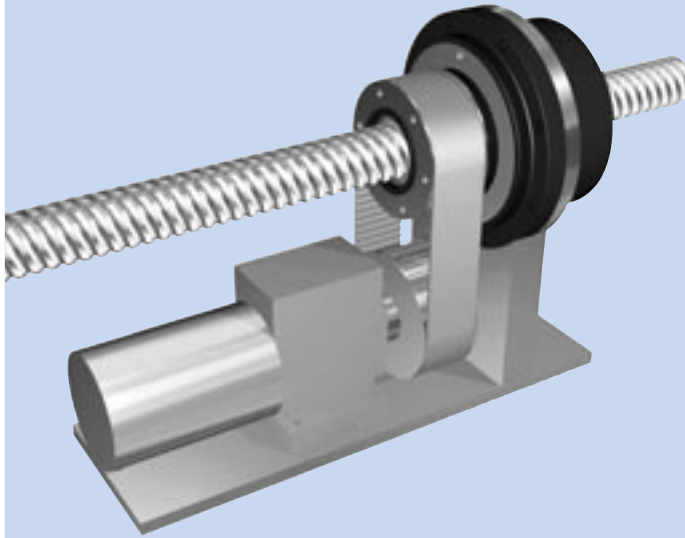
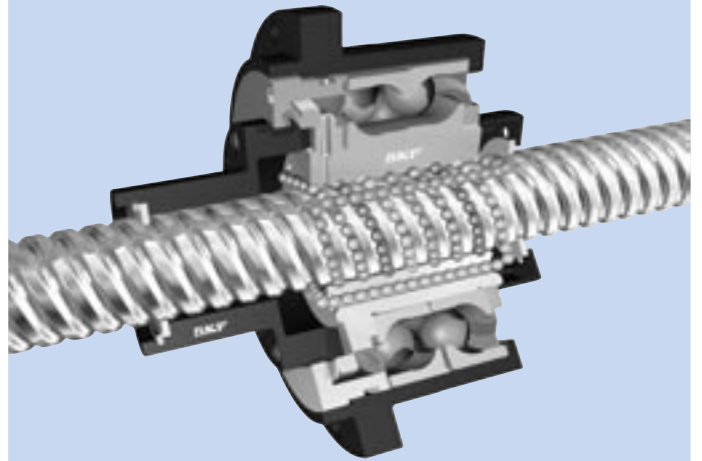

Figure 15



3

Designations	Ø1	Ø2	Ø3	Ø4	Ø5	Ø6	Ø7	L	L1	R1	R2	J1	J2	Z1×H1	Z2×H2× useful length	H3
	h8				g6						max	max			mm	
SLT/BLT 25×20	40	72.5	100	133	100	65	48	121.0	15	0.8	0.8	116	55	6×Ø9	6×M6×20	M6×1
SLT/BLT 25×25	40	72.5	100	133	100	65	48	126.2	15	0.8	0.8	116	55	6×Ø9	6×M6×20	M6×1
SLT/BLT 32×20	50	82	119.5	150	120	76	56	132.4	20	0.8	0.8	135	68	6×Ø9	6×M6×20	M6×1
SLT/BLT 32×32	50	82	119.5	150	120	76	50	126.8	20	0.8	0.8	135	68	6×Ø9	6×M6×20	M6×1
SLT/BLT 32×40	50	82	119.5	150	120	76	53	125.7	20	0.8	0.8	135	68	6×Ø9	6×M6×20	M6×1
SLT/BLT 40×20	58	93	125	159	125	80	63	136.4	20	0.8	0.8	142	75	8×Ø9	6×M6×20	M8×1
SLT/BLT 40×40	60	93	137	168	137	102	72	159.3	47	1.6	1.6	153	80	8×Ø9	6×M6×20	M8×1
SLT/BLT 50×50	70	120	170	210	170	110	85	163.3	20	1.6	1.6	190	106	8×Ø11	6×M8×30	M8×1

All tolerances js13 if not specified

3 Driving systems

Ball screws

Shaft end combinations for rolled ball screws

In the order code, shaft end machining is defined by:

- one letter for $\emptyset < 16$ mm
- two letters for $\emptyset \geq 16$ mm

resulting from the combination of two machined ends (see designation **page 106**).

Machined ends are represented in detail on **page 117** for $\emptyset < 16$ mm and **pages 118-119** for $\emptyset \geq 16$ mm

$\emptyset < 16$ mm		$\emptyset \geq 16$ mm	
Order code	Two machined ends	Order code	Two machined ends
A (without length indication)	cut only	AA (without length indication)	cut only
A (+ length)	cut + annealed		
B	1 + 2	BA	1A + 2A
F*	2 + 2	FA*	2A + 2A
G*	2 + 3	GA*	2A + 3A
H	2 + 4	HA	2A + 4A
J	2 + 5	JA	2A + 5A
M	3 + 5	MA	3A + 5A
S (+ length)	Ends to root diameter, any possible lengths.	SA (+ length)	Ends to root diameter d_2 , any possible lengths.
		UA [■] (+ length)	End machined to diameter d_3 under induction hardening, any possible lengths.
K	Keyway	K	Keyway
Z	To customer's drawing	Z	To customer's drawing

* Attention! This mounting requires the greatest precautions. Please contact us.

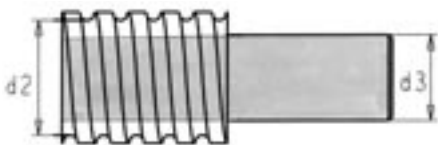

■ UA: end machined to diameter d_3 under induction hardening, any possible lengths.

Dimensions	$\emptyset d_2$	$\emptyset d_3$	Dimensions	$\emptyset d_2$	$\emptyset d_3$
	mm			mm	
16 × 5	12.7	9	32 × 32	28.4	26
20 × 5	16.7	14	32 × 40	26.9	24
25 × 5	21.7	19	40 × 5	36.7	34
25 × 10	20.5	18	40 × 10	34.0	31
25 × 20	21.7	19	40 × 20	35.2	32
25 × 25	21.5	18	40 × 40	34.2	31
32 × 5	28.7	26	50 × 10	44.0	41
32 × 10 DIN	27.8	25	50 × 50	43.5	40
32 × 10	26.0	23	63 × 10	57.0	54
32 × 20	27.5	24			

Symbols = see **page 151**

Standard end machining for nominal diameter < 16 mm

Special ends are machined to customer drawing on request

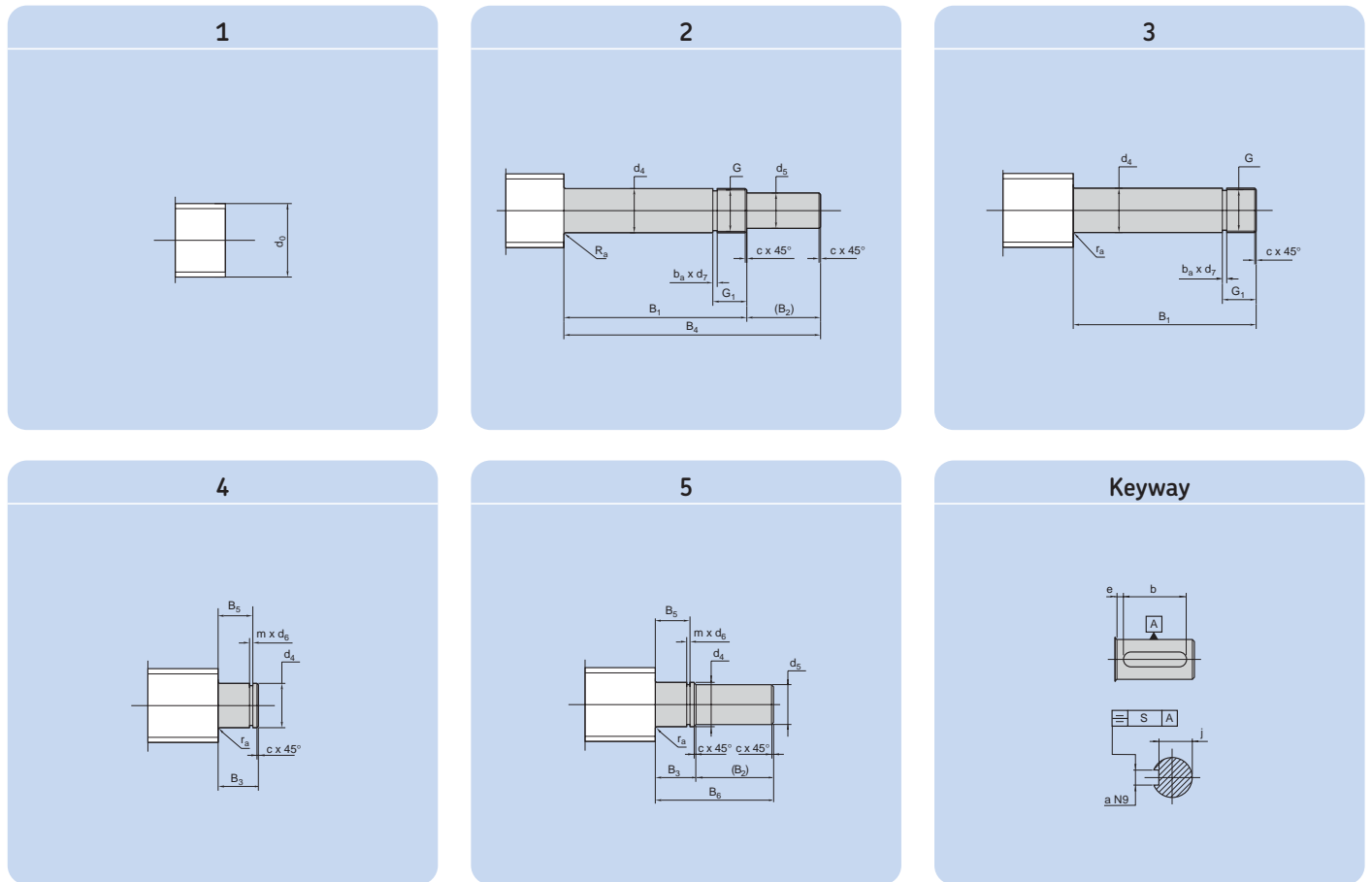

 End length

Symbols = see page 151

Size	d ₅	d ₄	B ₁	B ₂	B ₃	B ₄	B ₅	B ₆	G	G ₁	m	d ₆	c	b _a	d ₇	r _a	a	b	e	j	S	Keyway	
d ₀	h7	js7	js12		js12	js12	H11	js12	6g			+0.14 0	h11/h12		h11	maxi	N9	+0.5 0					DIN 6885
6	3	4	22	10	7	32	5.4	17	M4×0.7	7	0.5	3.8	0.5	1.2	2.9								
8	4	5	24	12	7	36	5.6	19	M5×0.8	7.2	0.7	4.8	0.5	1.2	3.7	0.3							
10	5	6	26	12	9	38	6.7	21	M6×1	7.5	0.8	5.7	0.5	1.5	4.5	0.3							
12/12.7	6	8	38	12	10	50	7.8	22	M8×1	12.5	0.9	7.6	0.5	1.5	6.5	0.3	2	8	3	4.8	0.1	A2×2×8	
14	8	10	40	16	12	56	9.0	28	M10×1.5	13.3	1.1	9.6	0.5	2.3	7.8	0.3	2	10	3	6.8	0.1	A2×2×10	

3 Driving systems

Ball screws

Standard end machining for nominal diameter ≥ 16 mm

Standard shaft ends for ball screws, nominal diameter ≥ 16 mm, have been developed to suit the SKF thrust bearings FLBU, PLBU and BUF.

These standard ends are the same for all screw types.

However, for the "SL/TL" long lead screw, an additional shoulder, part of the threaded length, will be machined to protect the

wiper and nut thread during assembly (both sides). Apart from this, the end itself is the same for all screw types.

For SD/BD, SX/BX, SN/BN/PN, SND/BD/PND

Dimensions																				Keyway to							
Size	d ₅	d ₄	d ₁₀	d ₁₁	d ₁₂	B ₁	B ₂	B ₃	B ₄	B ₅	B ₆	B ₇	B ₉	d ₈	G	G ₁	m	d ₆	c	c ₁	b _a	d ₇	r _a	DIN 6885			
d ₀	h7	h6		h6	h7	js12		js12	js12	H11	js12				6g			+0.14	h11				h11		fixed end	free end	
																		+0	h12					(type 2A)	(type 5A)		
mm																											
16	8	10	/	10	8	53	16	13	69	10	29	2	0	12.5	M10×0.75	17	1.1	9.6	0.5	0.5	1.2	8.8	0.4	A2×2×12	A2×2×12		
20	10	12	/	10	8	58	17	13	75	10	29	2	0	14.5	M12×1	18	1.1	9.6	0.5	0.5	1.5	10.5	0.8	A3×3×12	A2×2×12		
25	15	17	/	17	15	66	30	16	96	13	46	4.5	0	20	M17×1	22	1.1	16.2	0.5	0.5	1.5	15.5	0.8	A5×5×25	A5×5×25		
32	17	20	/	17	15	69	30	16	99	13	46	4.5	0	21.7	M20×1	22	1.1	16.2	0.5	0.5	1.5	18.5	1.2	A5×5×25	A5×5×25		
40	25	30	/	30	25	76	45	22	121	17.5	67	4.5	0	33.5	M30×1.5	25	1.6	28.6	1	0.5	2.3	27.8	0.8	A8×7×40	A8×7×40		
50	30	35	/	30	25	84	55	22	139	17.5	67	4.5	0	35.5	M35×1.5	27	1.6	28.6	1	0.5	2.3	32.8	1.2	A8×7×45	A8×7×40		
63	40	50	/	45	40	114	65	28	179	20.75	93	3	0	54	M50×1.5	32	1.85	42.5	1.5	1	2.3	47.8	1.2	A12×8×50	A12×8×50		

¹⁾ For ends 4A or 5A

For SL/BL only

Symbols = see page 151

Dimensions																				Keyway to							
Size	d ₅	d ₄	d ₁₀	d ₁₁	d ₁₂	B ₁	B ₂	B ₃	B ₄	B ₅	B ₆	B ₇	B ₉	d ₈	G	G ₁	m	d ₆	c	c ₁	b _a	d ₇	r _a	DIN 6885			
d ₀	h7	h6		h6	h7	js12		js12	js12	H11	js12				6g			+0.14	h11				h11		fixed end	free end	
																		+0	h12					(type 2A)	(type 5A)		
mm																											
25×20	15	17	/	17	15	66	30	16	96	13	46	4.5	0	21.7	M25×20	22	1.1	16.2	0.5	0.5	1.5	15.5	0.8	A5×5×25	A5×5×25		
25×25	15	17	/	17	15	66	30	16	96	13	46	4.5	0	21.5	M25×25	22	1.1	16.2	0.5	0.5	1.5	15.5	0.8	A5×5×25	A5×5×25		
32×20	17	20	21.5	17	15	69	30	16	99	13	46	4.5	2	27.4	M32×20	22	1.1	16.2	0.5	0.5	1.5	18.5	0.8 ¹⁾	A5×5×25	A5×5×25		
32×32	17	20	21.5	17	15	69	30	16	99	13	46	4.5	2	28.4	M32×32	22	1.1	16.2	0.5	0.5	1.5	18.5	0.8 ¹⁾	A5×5×25	A5×5×25		
32×40	17	20	21.5	17	15	69	30	16	99	13	46	4.5	2	26.9	M32×40	22	1.1	28.6	0.5	0.5	1.5	18.5	0.8 ¹⁾	A5×5×25	A5×5×25		
40×20	25	30	/	30	25	76	45	22	121	17.5	67	6.5	0	35.2	M40×20	25	1.6	28.6	1	0.5	2.3	27.8	15.5	A8×7×40	A8×7×40		
40×40	25	30	/	30	25	76	45	22	121	17.5	67	6.5	0	35.0	M40×40	25	1.6	28.6	1	0.5	2.3	27.8	18.5	A8×7×40	A8×7×40		
50×50	30	35	37	30	25	84	55	22	139	17.5	67	4.5	3	43.4	M50×50	27	1.6	28.6	1	0.5	2.3	32.8	0.8 ¹⁾	A8×7×45	A8×7×40		

¹⁾ For ends 4A or 5A

Standard machined ends for nominal diameter ≥ 16 mm

Threaded length = total length – end length

 End length

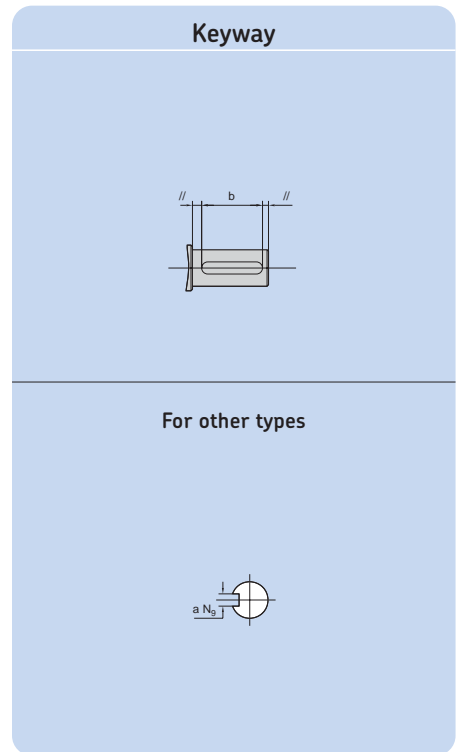
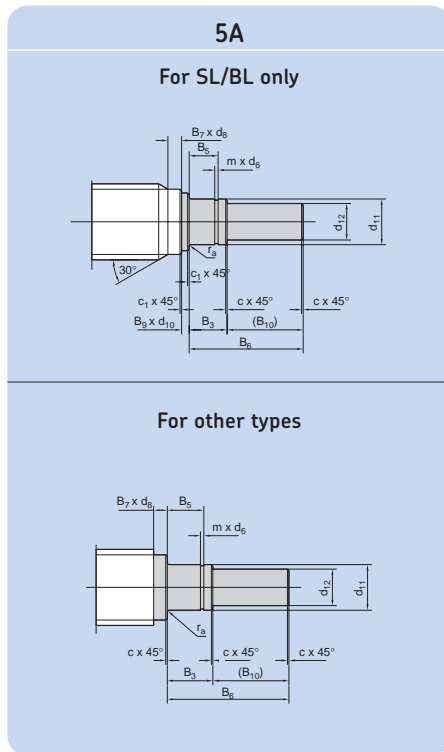
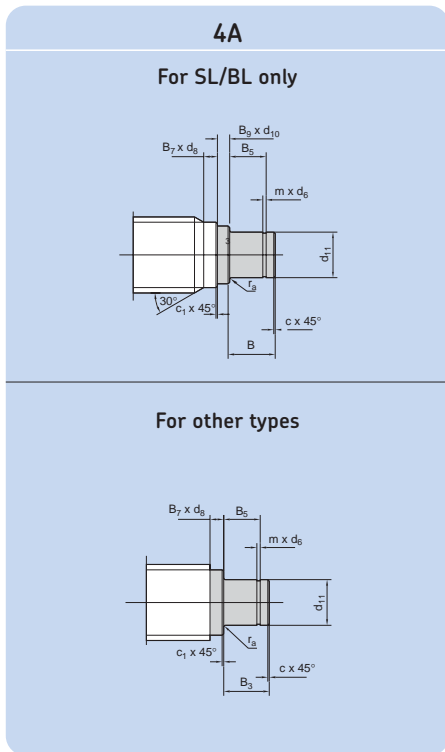
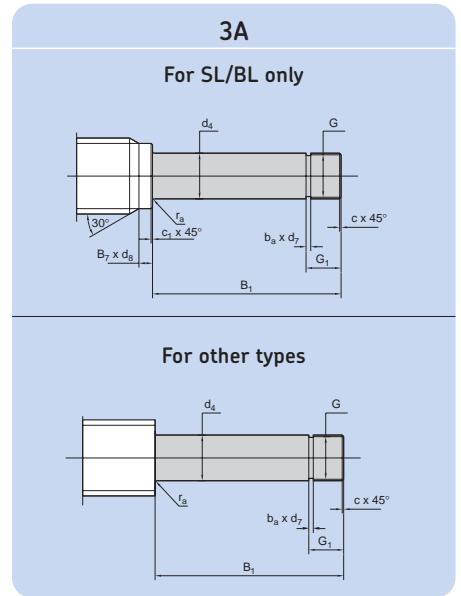
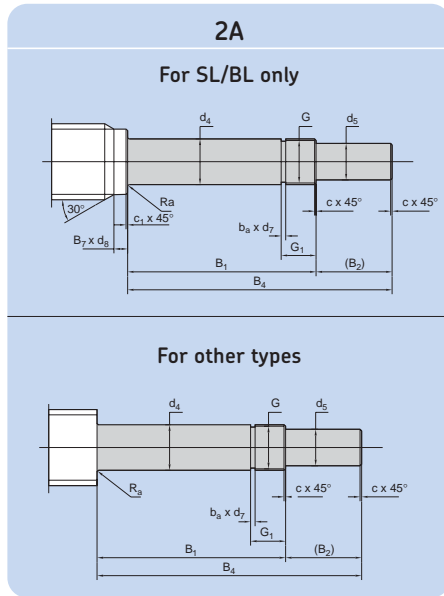
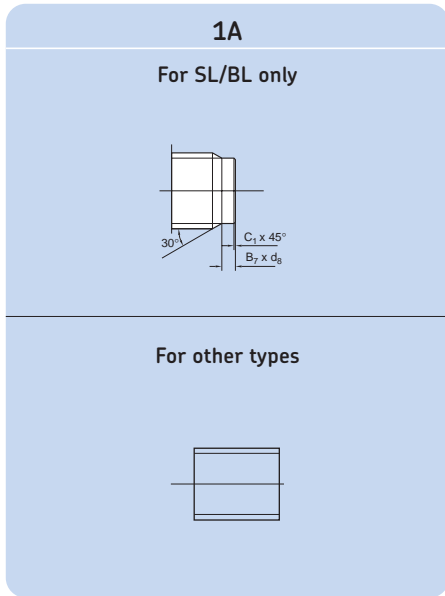

Symbols = see page 151

3 Driving systems

Ball screws

PLBU

Accessories for screw shaft, plummer bearing units:

End bearings, fixed plummer housing with angular contact ball bearings (back-to-back arrangement).

Designed for standard end machining 2A or 3A

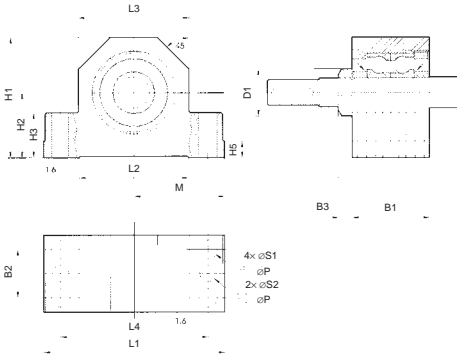

Designations	Dimensions								Basic load ratings	
	d ₀	B ₁	B ₂	H ₁	H ₂ JS7	L ₁	L ₄	S ₁ H12	dynamic C _a	static C _{0a}
	mm								kN	
PLBU 16	16	37	23	58	32	86	68	9	12.2	12.8
PLBU 20	20	42	25	64	34	94	77	9	13.3	14.7
PLBU 25	25	46	29	72	39	108	88	11	27.9	31.9
PLBU 32	32	49	29	77	45	112	92	11	24.6	31.9
PLBU 40	40	53	32	98	58	126	105	13	41.9	59.6
PLBU 50	50	59	35	112	65	144	118	13	54.5	79.8
PLBU 63	63	85	40	130	65	190	160	13	128	196.1

FLBU

Accessories for screw shaft, flanged bearing units:

End bearings, axially locating flanged housing with angular contact ball bearings (back-to-back arrangement).

Designed for standard end machining 2A or 3A

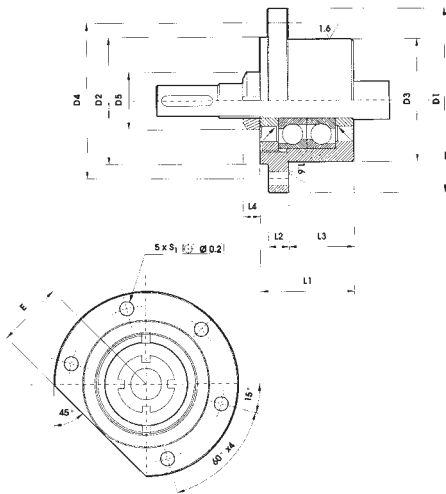

Designations	Dimensions							Basic load ratings	
	d ₀	D ₁	D ₃ h7	D ₄	L ₁	L ₃	S ₁ H13	dynamic C _a	static C _{0a}
	mm							kN	
FLBU 16	16	76	47	63	37	22	6.6	12.2	12.8
FLBU 20	20	76	47	63	42	25	6.6	13.3	14.7
FLBU 25	25	90	60	76	46	32	6.6	27.9	31.9
FLBU 32	32	90	60	74	49	32	9	24.6	31.9
FLBU 40	40	120	80	100	53	32	11	41.9	59.6
FLBU 50	50	130	90	110	59	32	13	54.5	79.8
FLBU 63	63	165	124	146	85	43.5	13	128	196.1

Symbols = see page 151

BUF - Plummer bearings

End bearings, axially free plummer housing with deep-groove ball bearing. Designed for standard end machining 4A or 5A

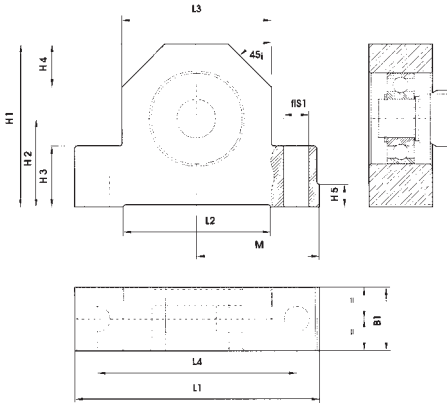

FBS - Q

Accessories for ground shaft, flanged bearing units:

End bearings, axially locating flanged housing with high precision angular contact ball bearings (back-to-back arrangement, 4 matched in set)

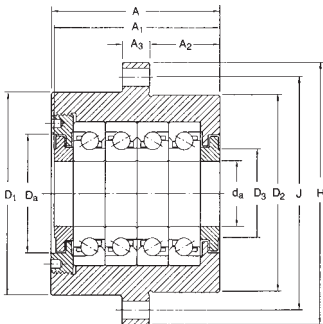

FBS - D

Accessories for ground shaft, flanged bearing units:

End bearings, axially locating flanged housing with high precision angular contact ball bearings (back-to-back arrangement, 2 matched in set)

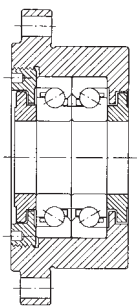

Symbols = see page 151

Designations	Dimensions							Basic load ratings	
	d_0	B_1	H_1	H_2	L_1	L_4	S_1	dynamic C_a	static C_{0a}
	mm							kN	
BUF 16	16	24	58	32	86	68	9	5.07	2.36
BUF 20	20	26	64	34	94	77	9	5.07	2.36
BUF 25	25	28	72	39	108	88	11	9.56	4.75
BUF 32	32	34	77	45	112	92	11	9.56	4.75
BUF 40	40	38	98	58	126	105	13	19.5	11.2
BUF 50	50	39	112	65	144	118	13	19.5	11.2
BUF 63	63	38	130	65	190	160	13	33.2	21.6

Designations	Dimensions							Basic load ratings		
	d_a	A	A_2	A_3	D_1	D_2	H	J	dynamic C	static C_o
	mm							kN		
FBS 204/QXXX	20	77	32	13	64	60	90	76	34.5	71
FBS 25/QXXX	25	82	32	15	88	80	120	102	53	116
FBS 30/QXXX	30	82	32	15	88	80	120	102	45.5	108
FBS 35/QXXX	35	82	32	15	98	90	130	113	57	143
FBS 40/QXXX	40	106	43.5	17	128	124	165	146	100	245
FBS 45/QXXX	45	106	43.5	17	128	124	165	146	129	320
FBS 50/QXXX	50	106	43.5	17	128	124	165	146	129	320

Designations	Dimensions							Basic load ratings		
	d_a	A	A_2	A_3	D_1	D_2	H	J	dynamic C	static C_o
	mm							kN		
FBS 204/DXXX	20	47	32	13	64	60	90	76	21.2	35.5
FBS 25/DXXX	25	52	32	15	88	80	120	102	32.5	58.5
FBS 30/DXXX	30	52	32	15	88	80	120	102	28.1	54
FBS 35/DXXX	35	52	32	15	98	90	130	113	35.1	71
FBS 40/DXXX	40	66	43.5	17	128	124	165	146	61.8	122
FBS 45/DXXX	45	66	43.5	17	128	124	165	146	79.3	160
FBS 50/DXXX	50	66	43.5	17	128	124	165	146	79.3	160

3 Driving systems

Ball screws

Ground ball screws (→ figure 16)

SKF offers a wide range of ground ball screws to cover all requirements

- Flanged nut with internal preload, DIN standard
- Double preloaded flanged nut, DIN standard
- Double cylindrical preloaded nut

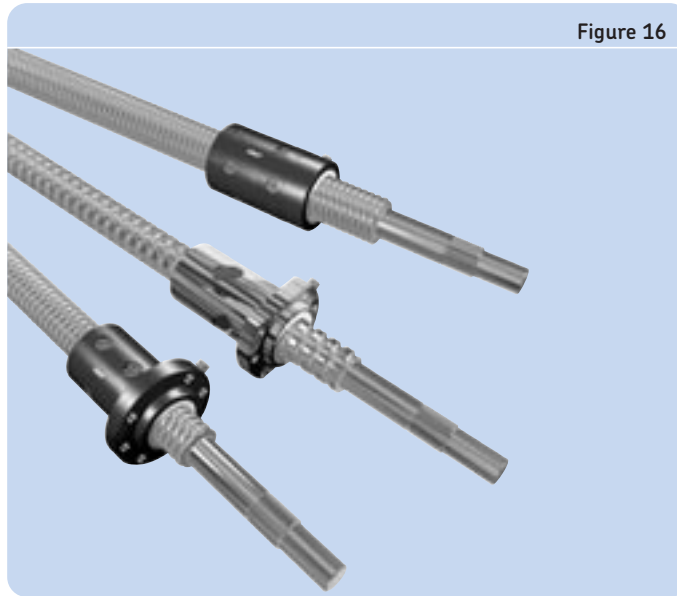
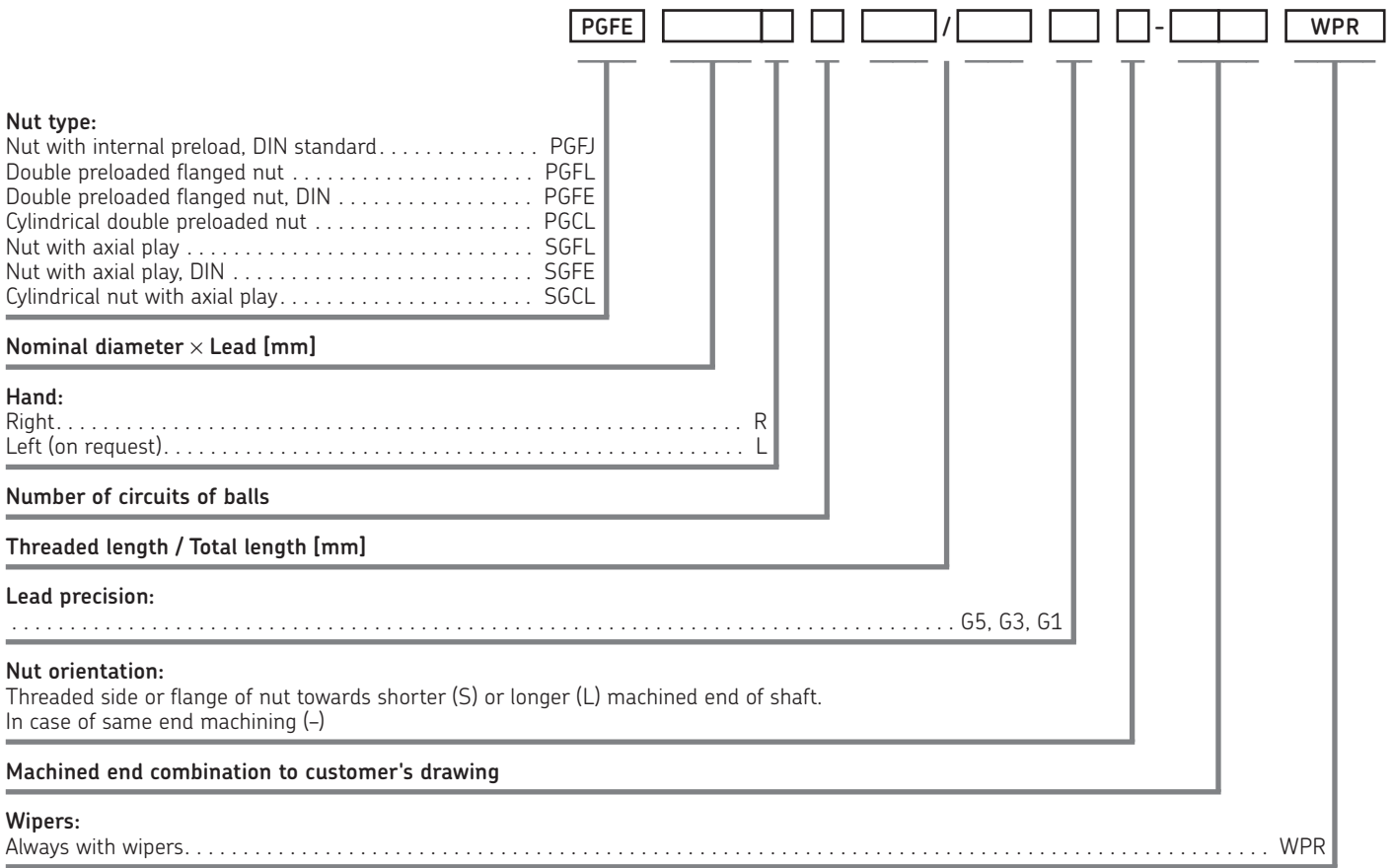

Figure 16

Table 4

Diameters	Leads	Nut types	Precision classes
From 16 to 125 mm	From 2 to 50 mm	Cylindrical or flanged nuts with preload or axial play	G1 - G3 - G5

Ordering key



3

Example: PGFE 32×5 R 5 330 / 445 G1 L - HA +K WPR

3 Driving systems

Ball screws

PGFE - Ground ball screws

Double flanged nut, preloaded, DIN standard

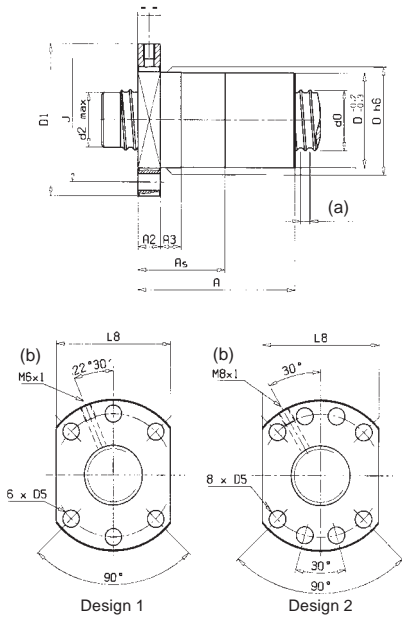

Legend:
(a) = lead
(b) = lubrication hole

Designations	Dimensions							Lead Ph	Basic load ratings		Design
	d ₀	D	D ₁	J	A	A ₂	L ₈		dynamic C _a	static C _{0a}	
	h6										
	mm								kN		
PGFE 16×5 R	16	28	48	38	79	12	40	5	9.7	14.2	1
PGFE 20×5 R	20	36	58	47	79	12	44	5	13.4	24.5	1
PGFE 25×5 R	25	40	62	51	88	14	48	5	15.6	33.6	1
PGFE 25×10 R	25	40	62	51	123	15	48	10	20.2	39.5	1
PGFE 32×5 R3	32	50	80	65	89	15	62	5	17.3	42.8	1
PGFE 32×10 R	32	50	80	65	146	18	62	10	42.2	80	1
PGFE 40×5 R	40	63	93	78	100	16	70	5	24.6	73	2
PGFE 40×10 R	40	63	93	78	146	18	70	10	46.5	98	2
PGFE 50×10 R	50	75	110	93	168	20	85	10	68	170	2
PGFE 63×10 R	63	90	125	108	170	22	95	10	77.5	227	2

PGFJ - Ground ball screws

Flanged nut with internal preload, DIN standard

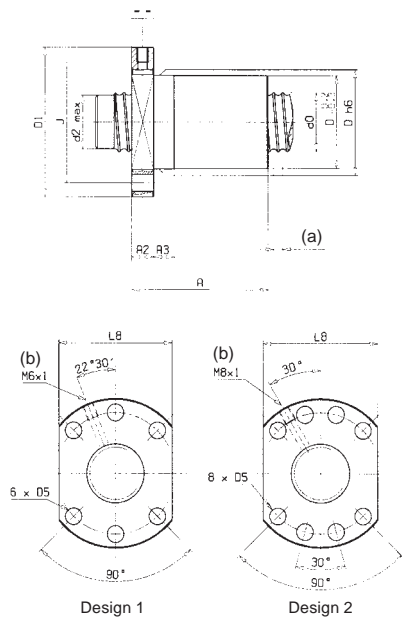

Legend:
(a) = lead
(b) = lubrication hole

Designations	Dimensions							Lead Ph	Basic load ratings		Design
	d ₀	D	D ₁	J	A	A ₂	L ₈		dynamic C _a	static C _{0a}	
	h6										
	mm								kN		
PGFJ 16×5 R	16	28	48	38	63	12	40	5	9.7	14.2	1
PGFJ 20×5 R	20	36	58	47	65	12	44	5	13.4	24.5	1
PGFJ 25×5 R	25	40	62	51	68	14	48	5	15.6	33.6	1
PGFJ 25×10 R	25	40	62	51	104	15	48	10	20.2	39.5	1
PGFJ 32×5 R	32	50	80	65	81	15	62	5	22.1	57	1
PGFJ 32×10 R	32	50	80	65	117	18	62	10	42.2	80	1
PGFJ 40×5 R	40	63	93	78	82	16	70	5	24.6	73	2
PGFJ 40×10 R	40	63	93	78	142	18	70	10	59.6	130	2
PGFJ 50×10 R	50	75	110	93	144	20	85	10	68	170	2
PGFJ 63×10 R	63	90	125	108	147	22	95	10	30	120	2

NB:

Thrust bearing units for ground ball screw See page 121.



There's no power without performance.



Most people think of the cheetah as the fastest animal because it can reach a speed of 100 kilometres per hour and can accelerate up to 70 in 2 seconds. Certainly this is amazing, but the cheetah doesn't possess the stamina of the gazelle which can race at 100 kilometres per hour for several minutes. SKF has drawn inspiration from this meeting of power with performance. Tools like the compact electromechanical cylinders combine the features of high acceleration, speed, compact dimensions, reliability and long duration. With SKF your applications will run safely for many years to come.

Linear motion from SKF
www.linearmotion.skf.com



3 Driving systems

Roller screws

Roller screws

Two non-competing designs to cover requirements beyond ball screw limitations. Load transfer from the nut to the screw shaft through a number of threaded or grooved rollers: the resulting large number of contact points ensures a much higher load carrying capacity and a much longer life than ball screws of similar size.

“SR” Planetary roller screws (→ figure 17)

Non-recirculating rollers yield high speed and acceleration capabilities, exceptional reliability and resistance to adverse environments.

“SV” Recirculating roller screws (→ figure 18)

Very fine lead of thread (1 mm) allows high positioning accuracy, repeatability and exceptional rigidity.

Figure 17

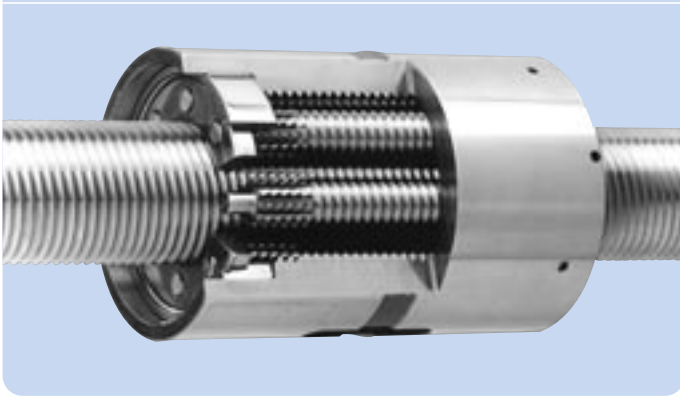
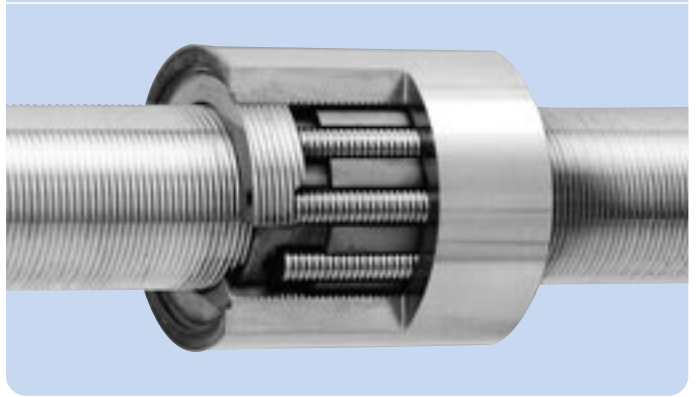

Figure 18



Ten reasons for using roller screws

- High load ratings (SR-SV)
- Very high rotational speed (SR)
- High acceleration and deceleration rates (SR)
- Long life at high cycle rates (SR)
- High reliability (SR-SV)
- Resistance to hostile surroundings (SR)
- Ability to accommodate shock loads (SR)
- Small displacements with very good repeatability (SV)
- Nut rotation when speed becomes critical (SR)
- Frequent removal of the nut from the screw shaft (SR, most SV)

Features

Type	Features
SR SV	Higher static load up to 12 000 kN
SR SV	Higher dynamic load up to 2 235 kN
SR	Higher rotational speed - Ø 48 at over 3 000 rpm
SR	Higher acceleration over 7 000 rad/sec ²
SR	Shock loads
SR	Adverse environments (dust, ice, sand)
SV	1 mm lead
SR SV	Stainless steel

Complete assemblies (→ figure 19)

Selected roller screws, both planetary and recirculating roller screws, are available within reduced delivery times, with customised screw shafts from premachined stocked units: see **pages 132-133** for planetary and **144-145** for recirculating roller screws.

The nuts are preloaded with oversize rollers, thus of load capacity as with the “split” nuts.

Lead precision G5 to ISO standard.

Ready for use

Roller screw and thrust bearing are delivered greased with SKF LGEP2. (Temperature range: $-20^{\circ}/+120^{\circ}\text{C}$)

Maximum speed

For screw assembly BR + FLRBU or BV + FLRBU, the maximum speed is defined by the product $n \times d_0$.

$$\begin{aligned} n \times d_0 &< 140\,000 \text{ for BR} \\ &< 20\,000 \text{ for BV} \end{aligned}$$

(n = rotational speed

d_0 = outside diameter of screw shaft)

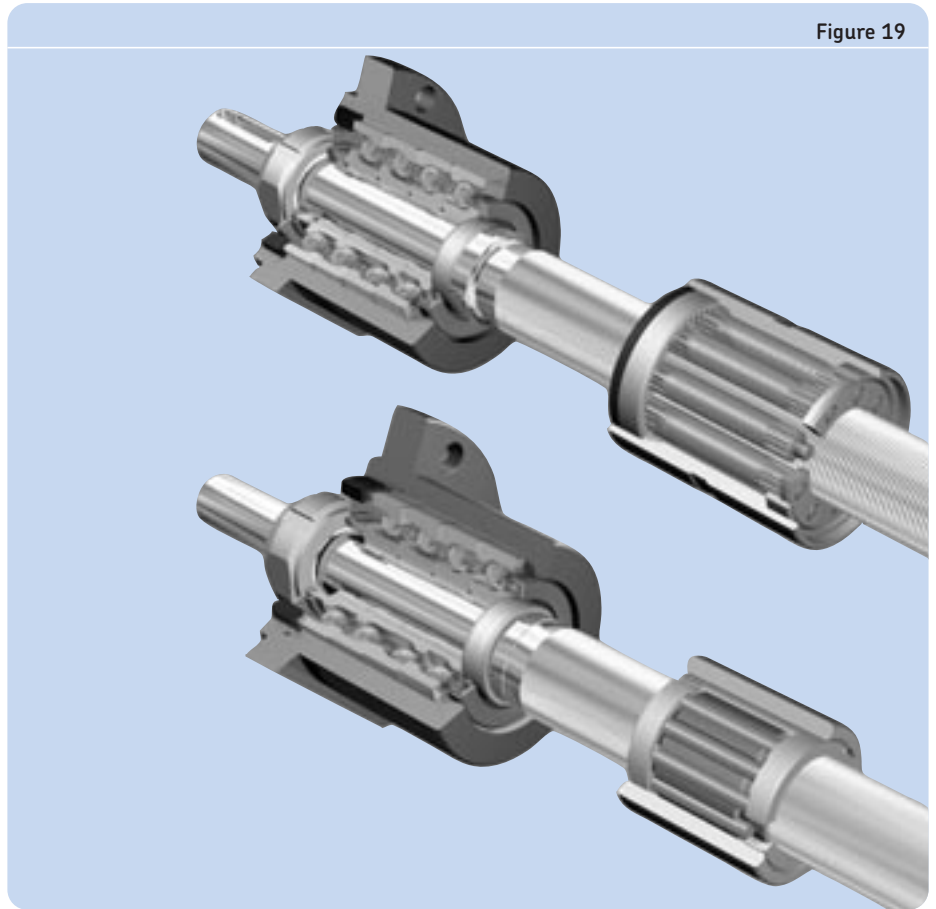

3 Driving systems

Roller screws

Planetary roller screws

(→ figure 20)

Features

- Many strong contact surfaces
- Non-recirculating rollers
- No weak point in the nut

Benefits

- Long life: high load carrying capacity
- Robust and shock resistant
- Exceptional reliability
- High speed & acceleration capabilities

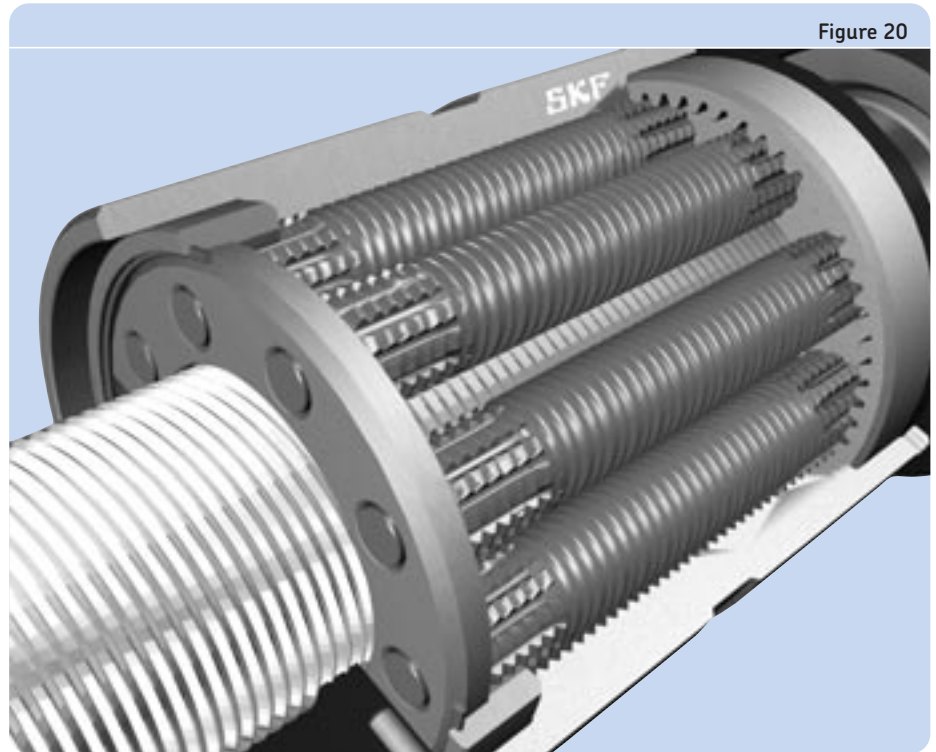

Figure 20

Threaded rollers are the basis of SR/BR/TR/PR planetary roller screws. (→ figure 21).

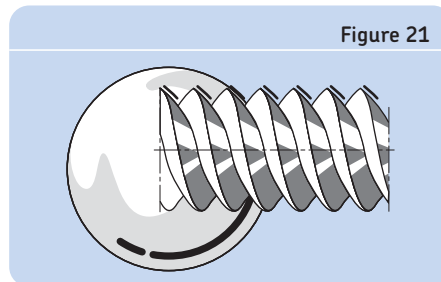

Figure 21

Typical applications

The capacity to carry heavy loads for thousands of hours in the most arduous conditions makes planetary roller screws suitable for the most demanding applications. The robust nut can withstand shock loads and the timing mechanism ensures reliability even in harsh environments and at high accelerations; the long lead and the symmetrical design of the nut permit high linear speeds.

Examples:

- Machine tools
- Steel industry
- Tyre industry
- Automatic handling
- Military aircraft, tanks, rocket launchers, radar, ships and submarines
- Nuclear industry

Recirculating roller screws (→ figure 22)

Features

- Many strong contact points
- Very small leads (1 mm)
- No miniature parts

Benefits

- Long life: high load carrying capacity
- High positioning accuracy: fine resolution
- Exceptional reliability

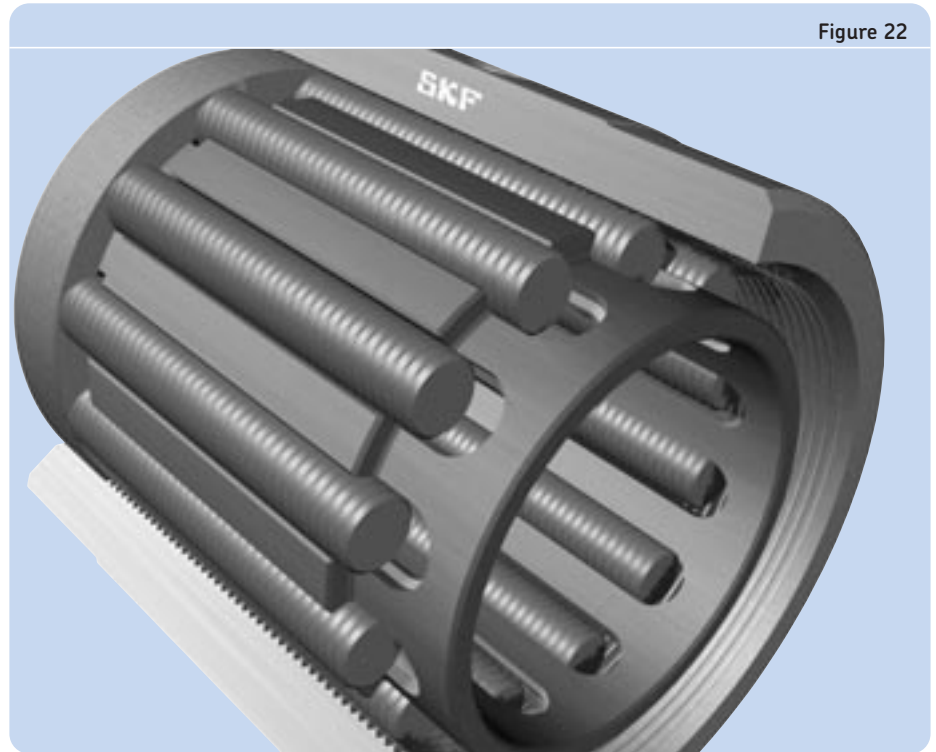

Figure 22

Grooved rollers are the basis of SV/PV recirculating roller screws (→ figure 23).

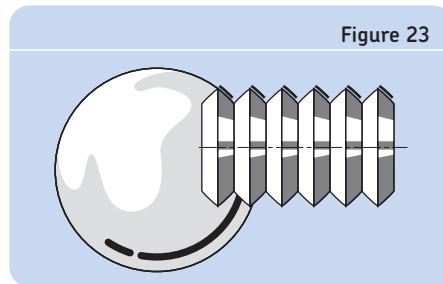

Figure 23

Typical applications

Ultimate positioning accuracy can be obtained using the fine lead of SV/BV/PV recirculating roller screws.

Their great mechanical advantage minimised input torque and increases resolution. They can simplify a complete transmission and improve its rigidity. They are often used in applications of advancing technology where reliable optimum performance is vital.

Examples:

- Grinding machines
- Laboratory equipment
- Hospital equipment
- Paper-making
- Printing industry
- Telescopes
- Satellites

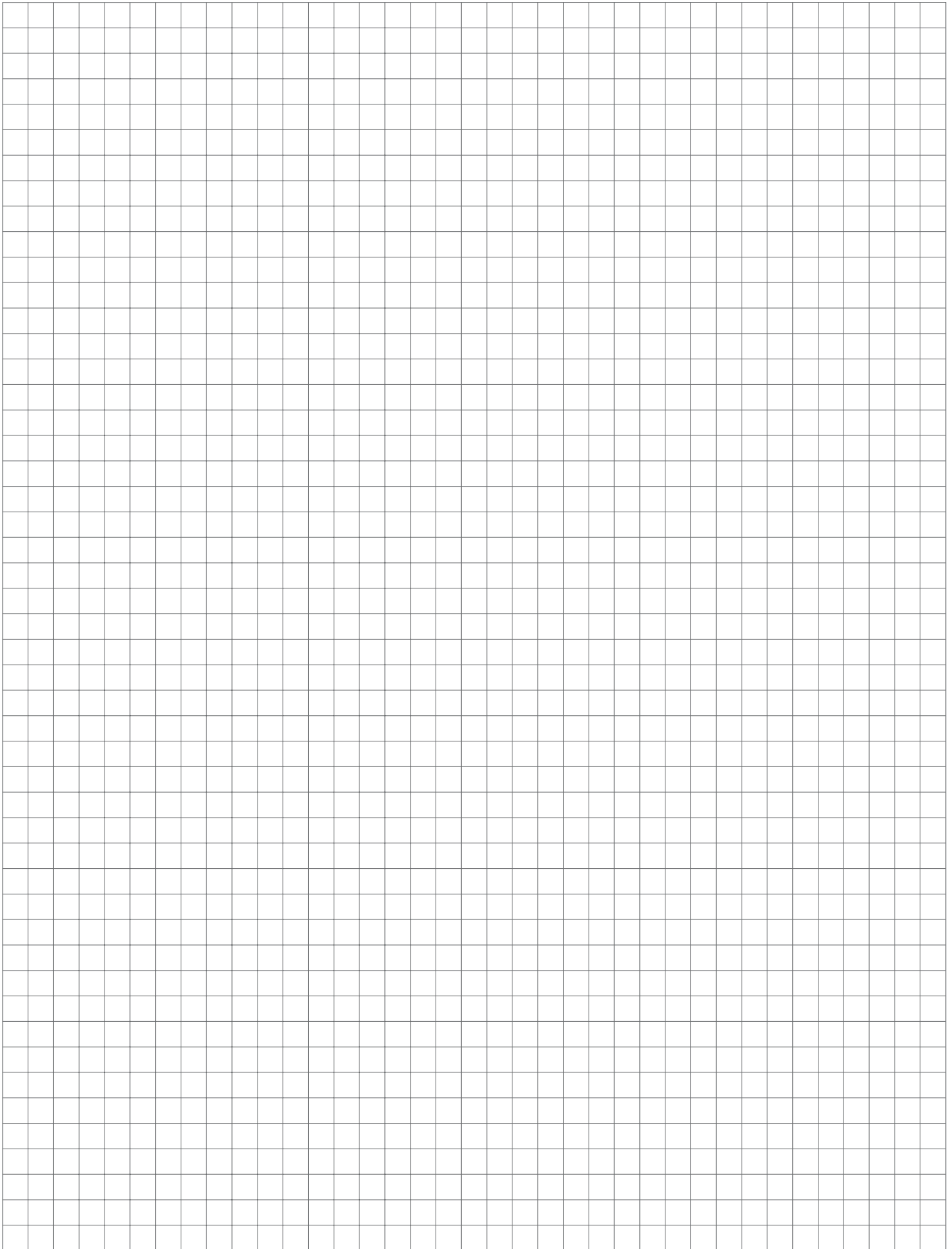

Ordering key



Play or preload:

- Axial play (standard range) S
- Axial play (Ultra Power range) H
- Preload by rollers to eliminate backlash B
- Nut preloaded for backlash elimination T
- Nut preloaded for optimum rigidity P

Product:

- Planetary roller screw R
- Recirculating roller screw V

Nut type:

- Cylindrical nut with axial play C
- Nut with central flange and axial play F
- Nut with non-central flange and axial play P
- Preloaded cylindrical nut U
- Preloaded nut with central flange K

Nominal diameter × Lead [mm]

Hand:

- Right R
- Left (on request) L

Threaded length, total length [mm]

Lead precision:

. G1 - G3 - G5

Nut orientation:

(this only applies to flanged nuts SRF, SRP, TRK, PRK, PRP, PVK, PVP, HRP, HRF):

- For cylindrical nut -
- Shorter machined end, g6 side of nut towards S
- Longer machined end, g6 side of nut towards L

Shaft ends:

- To customer's drawing Z

Wipers:

- Wipers in the nut: mounted for SR, delivered separately for SVC WPR
- Without wipers NOWPR
- Nut without wiper recesses (non standard SR only) X

Example: **S R F** **39** × **20 R** **425** / **590** **G1** **Z** **WPR**

Example: **S R F** **39** × **20 R** **425** / **590** **G5** **L Z** **NOWPR**

3 Driving systems

Roller screws

Planetary roller screws

BRC – Range

Legend:

(a) = key

(b) = wiper

(c) = lubrication

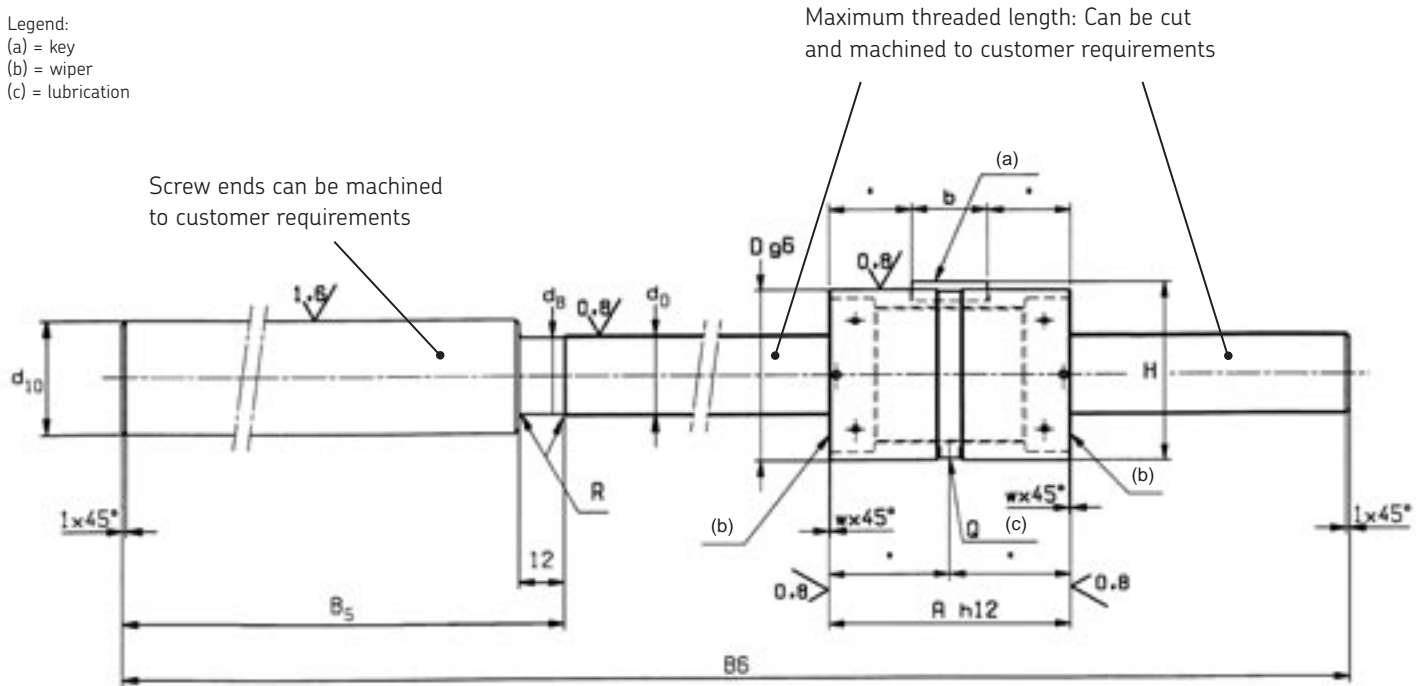

Planetary roller screws without end machining, lead precision G5 according to ISO standard.
Nut preloaded by rollers for backlash elimination.

Designations	Dimensions						Basic load ratings	
	d_0	B_6	d_{10}	B_5	D	A	dynamic C_a	static C_{0a}
	mm						kN	
BRC 15×5-R5	15	400	25	115	35	50	25.9	43.5
BRC 21×5-R5	21	570	40	178	45	64	50.5	81.9
BRC 30×5-R5	30	800	50	213	64	85	91.9	178.3
BRC 39×5-R5	39	1046	70	259	80	100	129.2	268.9

FLRBU / BRC – Range

Planetary roller screw with thrust bearing unit

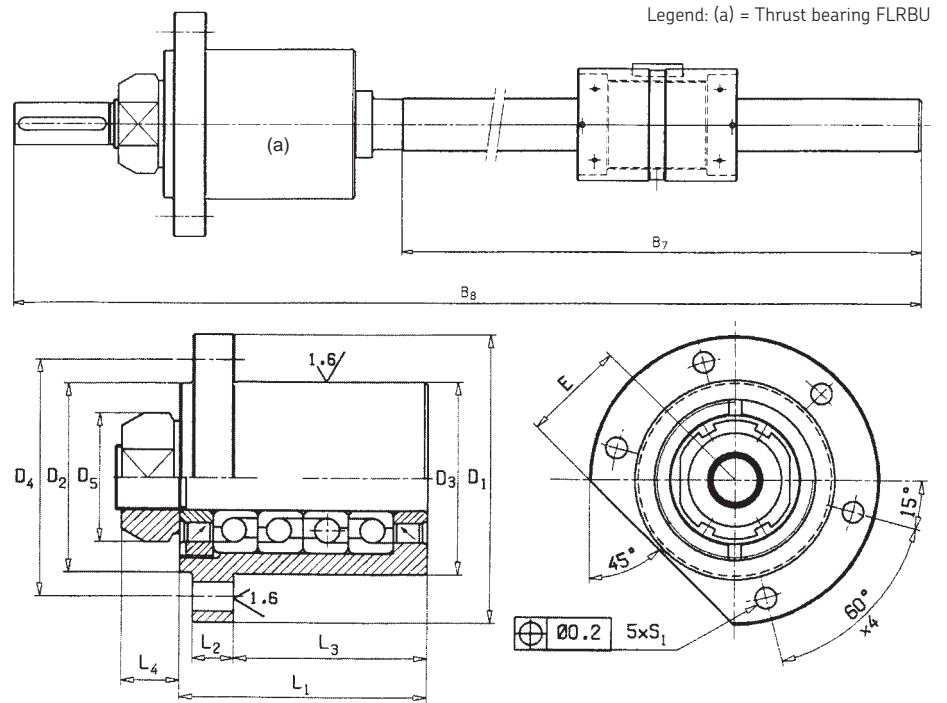

Designations	Dimensions										Basic load ratings	
	d ₀	B ₇	B ₈	L ₁	L ₂	L ₃	D ₁	D ₃	D ₄	E	dynamic C _a	static C _{0a}
	mm										kN	
FLRBU2 / BRC 15×5-R5	15	285	398	46	10	32	90	60	76	32	27.9	31.9
FLRBU4 / BRC 21×5-R5	21	392	568	77	13	60	90	60	74	32	40.1	63.8
FLRBU5 / BRC 30×5-R5	30	587	798	89	16	68	120	80	100	44	74.2	119.2
FLRBU6 / BRC 39×5-R5	39	787	1044	110	20	82	140	100	120	54	109.4	188.4

3 Driving systems

Roller screws

SRC - Range

Cylindrical nut with axial play

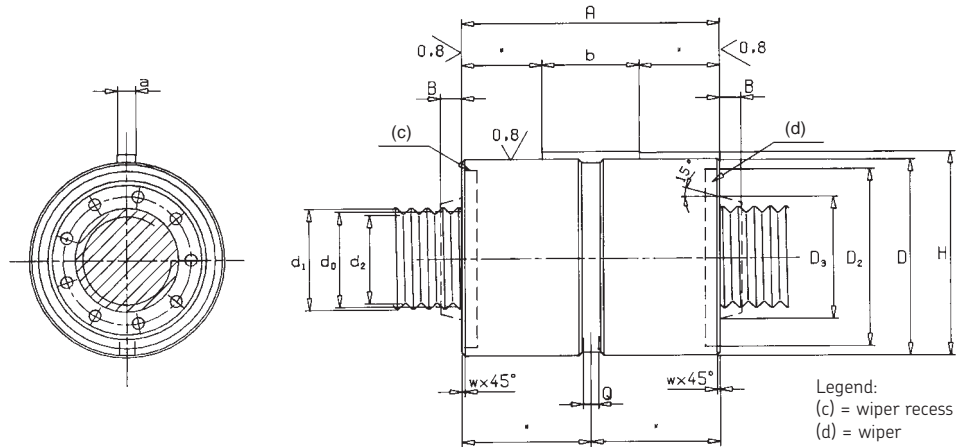

Designations	Dimensions											Basic load ratings		
	d_0	P_h	l_{tp}	s_{ap}	d_1	d_2	D	A	a	b	H	Q	C_a	C_{0a}
	mm											kN		
SRC 8×4	8	4	500	0.02	8.4	7.3	25	44	4	12	26.5	5	11.24	19.59
SRC 12×5	12	5	750	0.02	12.4	11.3	30	44	4	12	31.5	5	17.73	26.71
SRC 15×5	15	5	975	0.02	15.4	14.3	35	50	4	16	36.5	5	25.95	43.59
SRC 15×8	15	8	975	0.02	15.5	14.0	35	50	4	16	36.5	5	27.43	40.78
SRC 20×6	20	6	1300	0.02	20.4	19.3	40	50	4	16	41.5	5	26.83	44.86
SRC 21×5	21	5	1400	0.02	21.4	20.3	45	64	5	20	47.0	5	50.55	81.97
SRC 21×6	21	6	1400	0.02	21.4	20.3	45	64	5	20	47.0	5	52.77	82.18
SRC 21×8	21	8	1400	0.02	21.5	20.0	45	64	5	20	47.0	5	54.44	78.06
SRC 21×10	21	10	1400	0.04	21.8	19.7	45	64	5	20	47.0	5	59.24	83.01
SRC 24×6	24	6	1600	0.02	24.4	23.3	48	58	5	20	50.0	5	42.30	65.17
SRC 24×12	24	12	1600	0.04	24.8	22.7	48	58	5	20	50.0	5	47.65	62.34
SRC 25×5	25	5	1650	0.02	25.4	24.3	53	78	6	25	55.5	5	63.25	108.23
SRC 25×10	25	10	1650	0.04	25.8	23.7	53	78	6	25	55.5	5	72.63	105.31
SRC 25×15	25	15	1650	0.07	26.2	23.1	53	78	6	25	55.5	5	79.17	106.39
SRC 30×5	30	5	2000	0.02	30.4	29.3	64	85	6	32	66.5	5	91.98	178.32
SRC 30×6	30	6	2000	0.02	30.4	29.3	64	85	6	32	66.5	5	95.00	175.34
SRC 30×10	30	10	2000	0.04	30.8	28.7	64	85	6	32	66.5	5	106.32	174.36
SRC 30×20	30	20	2000	0.07	31.5	27.5	64	85	6	32	66.5	5	123.28	177.28
SRC 36×6	36	6	2400	0.02	36.4	35.3	68	80	5	25	70.0	5	90.45	179.39
SRC 36×9	36	9	2400	0.02	36.5	35.1	68	80	5	25	70.0	5	97.52	174.05
SRC 36×12	36	12	2400	0.04	36.8	34.7	68	80	5	25	70.0	5	106.60	181.10
SRC 36×18	36	18	2400	0.07	37.2	34.1	68	80	5	25	70.0	5	114.14	176.57
SRC 36×24	36	24	2400	0.07	37.5	33.5	68	80	5	25	70.0	5	123.60	184.38
SRC 39×5	39	5	2650	0.02	39.4	38.3	80	100	8	40	83.0	7	129.21	268.92
SRC 39×10	39	10	2650	0.04	39.8	37.7	80	100	8	40	83.0	7	152.62	270.93
SRC 39×15	39	15	2650	0.07	40.2	37.1	80	100	8	40	83.0	7	167.64	272.89
SRC 39×20	39	20	2650	0.07	40.5	36.5	80	100	8	40	83.0	7	172.82	260.89
SRC 39×25	39	25	2650	0.07	40.9	35.9	80	100	8	40	83.0	7	174.79	249.00
SRC 44×8	44	8	3000	0.04	44.4	43.2	80	90	6	32	82.5	7	130.48	261.47
SRC 44×12	44	12	3000	0.04	44.8	42.7	80	90	6	32	82.5	7	143.71	262.87
SRC 44×18	44	18	3000	0.07	45.2	42.1	80	90	6	32	82.5	7	157.74	264.94
SRC 44×24	44	24	3000	0.07	45.5	41.5	80	90	6	32	82.5	7	167.81	266.95
SRC 44×30	44	30	3000	0.07	45.9	40.9	80	90	6	32	82.5	7	165.86	246.44

Continued

Symbols = see page 151

SRC - Range
(Continued)

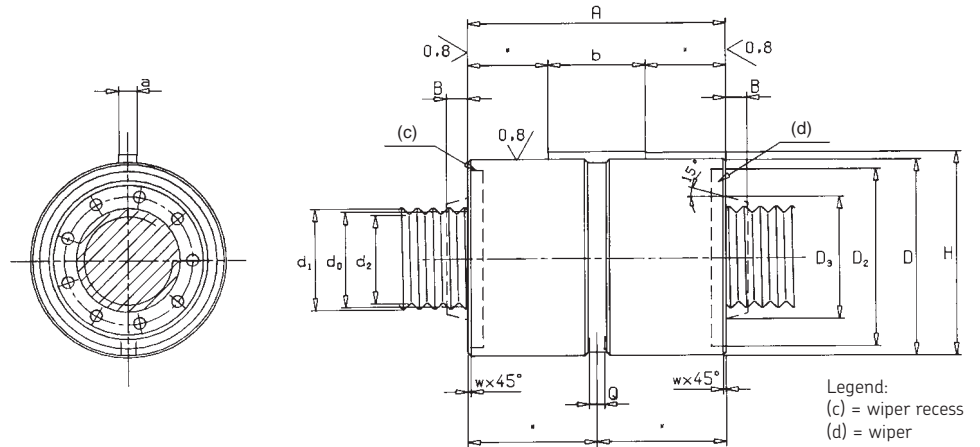

3

Designations		Dimensions											Basic load ratings		
													dynamic	static	
		d_0	P_h	l_{tp}	s_{ap}	d_1	d_2	D	A	a	b	H	Q	C_a	C_{oa}
		mm											kN		
SRC	48×5	48	5	3300	0.02	48.4	47.3	100	127	8	45	103.0	7.0	198.08	481.53
SRC	48×8	48	8	3300	0.04	48.6	47.1	100	127	8	45	103.0	7.0	218.43	470.61
SRC	48×10	48	10	3300	0.04	48.8	46.7	100	127	8	45	103.0	7.0	231.54	475.11
SRC	48×15	48	15	3300	0.07	49.2	46.1	100	127	8	45	103.0	7.0	257.75	486.36
SRC	48×20	48	20	3300	0.07	49.5	45.5	100	127	8	45	103.0	7.0	265.69	462.27
SRC	48×25	48	25	3300	0.07	49.9	44.9	100	127	8	45	103.0	7.0	285.86	491.04
SRC	56×12	56	12	4000	0.04	56.8	54.7	100	112	8	40	103.0	7.0	212.17	433.12
SRC	56×24	56	24	4000	0.07	57.5	53.5	100	112	8	40	103.0	7.0	242.22	419.15
SRC	56×36	56	36	4000	0.07	58.3	52.3	100	112	8	40	103.0	7.0	258.33	424.24
SRC	60×10	60	10	4250	0.04	60.8	58.7	122	152	10	45	125.0	10.5	338.57	779.69
SRC	60×15	60	15	4250	0.07	61.2	58.1	122	152	10	45	125.0	10.5	373.06	782.69
SRC	60×20	60	20	4250	0.07	61.5	57.5	122	152	10	45	125.0	10.5	394.97	785.66
SRC	64×12	64	12	4600	0.04	64.8	62.7	115	129	8	45	118.0	7.0	296.38	763.30
SRC	64×18	64	18	4600	0.07	65.2	62.1	115	129	8	45	118.0	7.0	316.72	725.56
SRC	64×24	64	24	4600	0.07	65.5	61.5	115	129	8	45	118.0	7.0	328.93	689.62
SRC	64×30	64	30	4600	0.07	65.9	60.9	115	129	8	45	118.0	7.0	318.15	619.84
SRC	64×36	64	36	4600	0.07	66.3	60.3	115	129	8	45	118.0	7.0	309.12	589.38
SRC	75×10	75	10	5500	0.04	75.8	73.7	150	191	10	63	153.0	10.5	504.86	1486.68
SRC	75×15	75	15	5500	0.07	76.2	73.1	150	191	10	63	153.0	10.5	561.29	1491.30
SRC	75×20	75	20	5500	0.07	76.5	72.5	150	191	10	63	153.0	10.5	572.26	1495.87
SRC	80×12	80	12	6000	0.04	80.8	78.7	140	156	10	63	143.0	10.5	410.27	1163.16
SRC	80×18	80	18	6000	0.07	81.2	78.1	140	156	10	63	143.0	10.5	455.94	1167.63
SRC	80×24	80	24	6000	0.07	81.5	77.5	140	156	10	63	143.0	10.5	485.80	1172.06
SRC	80×36	80	36	6000	0.07	82.3	76.3	140	156	10	63	143.0	10.5	442.89	999.09
SRC	80×42	80	42	6000	0.07	82.7	75.7	140	156	10	63	143.0	10.5	425.64	932.95
SRC	99×20	99	20	7500	0.07	100.5	96.5	200	260	16	100	204.0	15.0	924.86	3090.44
SRC	100×24	100	24	8000	0.07	101.5	97.5	180	195	10	63	183.0	10.5	655.81	1825.82
SRC	120×24	120	24	8000	0.07	121.5	117.5	220	240	16	100	224.0	15.0	915.02	3027.05
SRC	120×25	120	25	8000	0.07	121.9	116.9	240	280	16	100	244.0	15.0	1127.43	4037.97
SRC	150×36	150	36	8000	0.07	152.3	146.3	280	305	16	100	284.0	15.0	1156.92	4108.09
SRC	150×25	150	25	8000	0.07	151.9	146.9	320	400	32	160	327.0	15.0	1596.53	6816.05
SRC	180×30	180	30	8000	0.07	182.3	176.3	420	515	32	160	427.0	20.0	1962.34	9069.02
SRC	210×30	210	30	8000	0.07	212.3	206.3	480	550	40	200	489.0	20.0	2295.60	11375.26

Symbols = see page 151

3 Driving systems

Roller screws

SRF - Range

Flanged nut with axial play

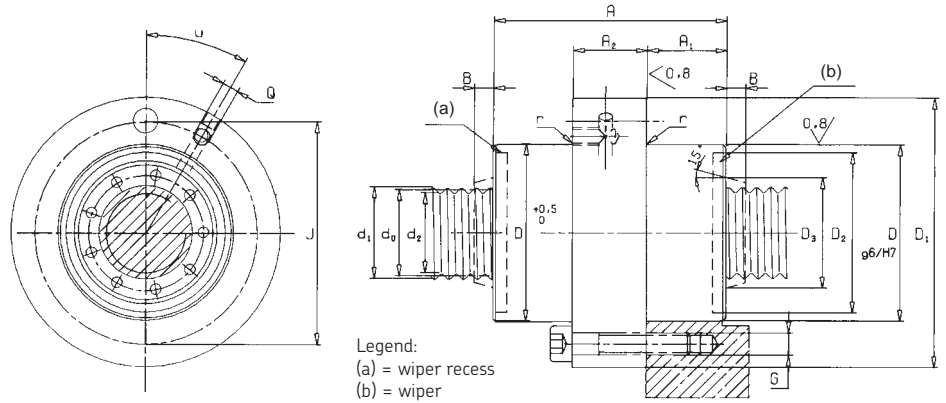

Designations	Dimensions													Basic load ratings	
	d_0	P_n	l_{tp}	s_{ap}	d_1	d_2	D	A	D_1	J	G	Q	u	dynamic C_a	static C_{0a}
	mm													[°]	kN
SRF 8×4	8	4	500	0.02	8.4	7.3	25	44	46	36	6×M4	M6	30	11.24	19.59
SRF 12×5	12	5	750	0.02	12.4	11.3	30	44	51	41	6×M4	M6	30	17.73	26.71
SRF 15×5	15	5	975	0.02	15.4	14.3	35	50	58	46	6×M5	M6	30	25.95	43.59
SRF 15×8	15	8	975	0.02	15.5	14	35	50	58	46	6×M5	M6	30	27.43	40.78
SRF 20×6	20	6	1300	0.02	20.4	19.3	40	50	63	51	6×M5	M6	30	26.83	44.86
SRF 21×5	21	5	1400	0.02	21.4	20.3	45	64	68	56	6×M5	M6	30	50.55	81.97
SRF 21×6	21	6	1400	0.02	21.4	20.3	45	64	68	56	6×M5	M6	30	52.77	82.18
SRF 21×8	21	8	1400	0.02	21.5	20	45	64	68	56	6×M5	M6	30	54.44	78.06
SRF 21×10	21	10	1400	0.04	21.8	19.7	45	64	68	56	6×M5	M6	30	59.24	83.01
SRF 24×6	24	6	1600	0.02	24.4	23.3	48	58	71	59	6×M5	M6	30	42.30	65.17
SRF 24×12	24	12	1600	0.04	24.8	22.7	48	58	71	59	6×M5	M6	30	47.65	62.34
SRF 25×5	25	5	1650	0.02	25.4	24.3	56	78	84	70	6×M6	M6	30	63.25	108.23
SRF 25×10	25	10	1650	0.04	25.8	23.7	56	78	84	70	6×M6	M6	30	72.63	105.31
SRF 25×15	25	15	1650	0.07	26.2	23.1	56	78	84	70	6×M6	M6	30	79.17	106.39
SRF 30×5	30	5	2000	0.02	30.4	29.3	64	85	97	81	6×M8	M6	30	91.98	178.32
SRF 30×6	30	6	2000	0.02	30.4	29.3	64	85	97	81	6×M6	M6	30	95.00	175.34
SRF 30×10	30	10	2000	0.04	30.8	28.7	64	85	97	81	6×M8	M6	30	106.32	174.36
SRF 30×20	30	20	2000	0.07	31.5	27.5	64	85	97	81	6×M8	M6	30	123.28	177.28
SRF 36×6	36	6	2400	0.02	36.4	35.3	68	80	102	85	6×M8	M6	30	90.45	179.39
SRF 36×9	36	9	2400	0.02	36.5	35.1	68	80	102	85	6×M8	M6	30	97.52	174.05
SRF 36×12	36	12	2400	0.04	36.8	34.7	68	80	102	85	6×M8	M6	30	106.60	181.10
SRF 36×18	36	18	2400	0.07	37.2	34.1	68	80	102	85	6×M8	M6	30	114.14	176.57
SRF 36×24	36	24	2400	0.07	37.5	33.5	68	80	102	85	6×M8	M6	30	123.60	184.38
SRF 39×5	39	5	2650	0.02	39.4	38.3	82	100	124	102	6×M10	M6	30	129.21	268.92
SRF 39×10	39	10	2650	0.04	39.8	37.7	82	100	124	102	6×M10	M6	30	152.62	270.93
SRF 39×15	39	15	2650	0.07	40.2	37.1	82	100	124	102	6×M10	M6	30	167.64	272.89
SRF 39×20	39	20	2650	0.07	40.5	36.5	82	100	124	102	6×M10	M6	30	172.82	260.89
SRF 39×25	39	25	2650	0.07	40.9	35.9	82	100	124	102	6×M10	M6	30	174.79	249.00
SRF 44×8	44	8	3000	0.04	44.4	43.2	82	90	124	102	6×M10	M6	30	130.48	261.47
SRF 44×12	44	12	3000	0.04	44.8	42.7	82	90	124	102	6×M10	M6	30	143.71	262.87
SRF 44×18	44	18	3000	0.07	45.2	42.1	82	90	124	102	6×M10	M6	30	157.74	264.94
SRF 44×24	44	24	3000	0.07	45.5	41.5	82	90	124	102	6×M10	M6	30	167.81	266.95
SRF 44×30	44	30	3000	0.07	45.9	40.9	82	90	124	102	6×M10	M6	30	165.86	246.44

Continued

Symbols = see page 151

SRF - Range
(Continued)

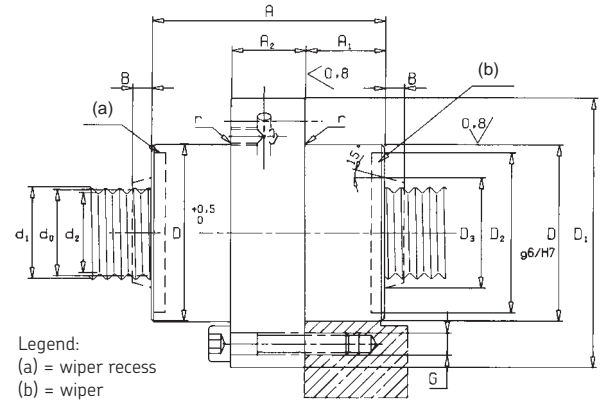
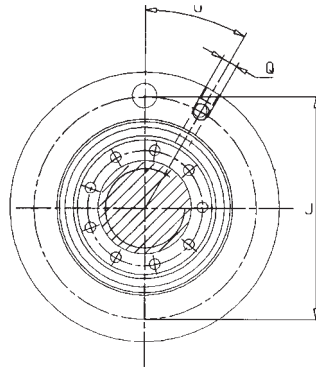

Designations	Dimensions													Basic load ratings	
	d_0	P_h	l_{tp}	s_{ap}	d_1	d_2	D	A	D_1	J	G	Q	u	C_a	C_{0a}
	mm													[°]	kN
SRF 48×5	48	5	3300	0.02	48.4	47.3	105	127	150	127	6×M12	M8×1	30	198.08	481.53
SRF 48×8	48	8	3300	0.04	48.6	47.1	105	127	150	127	6×M12	M8×1	30	218.43	470.61
SRF 48×10	48	10	3300	0.04	48.8	46.7	105	127	150	127	6×M12	M8×1	30	231.54	475.11
SRF 48×15	48	15	3300	0.07	49.2	46.1	105	127	150	127	6×M12	M8×1	30	257.75	486.36
SRF 48×20	48	20	3300	0.07	49.5	45.5	105	127	150	127	6×M12	M8×1	30	265.69	462.27
SRF 48×25	48	25	3300	0.07	49.9	44.9	105	127	150	127	6×M12	M8×1	30	285.86	491.04
SRF 56×12	56	12	4000	0.04	56.8	54.7	105	112	150	127	6×M12	M8×1	30	212.17	433.12
SRF 56×24	56	24	4000	0.07	57.5	53.5	105	112	150	127	6×M12	M8×1	30	242.22	419.15
SRF 56×36	56	36	4000	0.07	58.3	52.3	105	112	150	127	6×M12	M8×1	30	258.33	424.24
SRF 60×10	60	10	4250	0.04	60.8	58.7	122	152	180	150	6×M16	M8×1	30	338.57	779.69
SRF 60×15	60	15	4250	0.07	61.2	58.1	122	152	180	150	6×M16	M8×1	30	373.06	782.69
SRF 60×20	60	20	4250	0.07	61.5	57.5	122	152	180	150	6×M16	M8×1	30	394.97	785.66
SRF 64×12	64	12	4600	0.04	64.8	62.7	120	129	180	150	6×M16	M8×1	30	296.38	763.30
SRF 64×18	64	18	4600	0.07	65.2	62.1	120	129	180	150	6×M16	M8×1	30	316.72	725.56
SRF 64×24	64	24	4600	0.07	65.5	61.5	120	129	180	150	6×M16	M8×1	30	328.93	689.62
SRF 64×30	64	30	4600	0.07	65.9	60.9	120	129	180	150	6×M16	M8×1	30	318.15	619.84
SRF 64×36	64	36	4600	0.07	66.3	60.3	120	129	180	150	6×M16	M8×1	30	309.12	589.38
SRF 75×10	75	10	5500	0.04	75.8	73.7	150	191	210	180	8×M16	M8×1	22°30	504.86	1486.68
SRF 75×15	75	15	5500	0.07	76.2	73.1	150	191	210	180	8×M16	M8×1	22°30	561.29	1491.30
SRF 75×20	75	20	5500	0.07	76.5	72.5	150	191	210	180	8×M16	M8×1	22°30	572.26	1495.87
SRF 80×12	80	12	6000	0.04	80.8	78.7	150	156	210	180	8×M16	M8×1	22°30	410.27	1163.16
SRF 80×18	80	18	6000	0.07	81.2	78.1	150	156	210	180	8×M16	M8×1	22°30	455.94	1167.63
SRF 80×24	80	24	6000	0.07	81.5	77.5	150	156	210	180	8×M16	M8×1	22°30	485.80	1172.06
SRF 80×36	80	36	6000	0.07	82.3	76.3	150	156	210	180	8×M16	M8×1	22°30	442.89	999.09
SRF 80×42	80	42	6000	0.07	82.7	75.7	150	156	210	180	8×M16	M8×1	22°30	425.64	932.95
SRF 99×20	99	20	7500	0.07	100.5	96.5	200	260	275	245	12×M16	M8×1	15	924.86	3090.44
SRF 100×24	100	24	8000	0.07	101.5	97.5	180	195	255	220	12×M16	M8×1	15	655.81	1825.82
SRF 120×24	120	24	8000	0.07	121.5	117.5	220	240	295	260	12×M16	M8×1	15	915.02	3027.05
SRF 120×25	120	25	8000	0.07	121.9	116.9	260	280	340	305	12×M16	M12	15	1127.43	4037.97
SRF 150×36	150	36	8000	0.07	152.3	146.3	280	305				Consult SKF		1156.92	4108.09
SRF 150×25	150	25	8000	0.07	151.9	146.9	320	400				Consult SKF		1596.53	6816.05
SRF 180×30	180	30	8000	0.07	182.3	176.3	420	515				Consult SKF		1962.34	9069.02
SRF 210×30	210	30	8000	0.07	212.3	206.3	480	550				Consult SKF		2295.60	11375.26

Symbols = see page 151

3 Driving systems

Roller screws

TRU / PRU - Range

Cylindrical nut with backlash elimination (TRU) or preloaded for optimum rigidity (PRU)

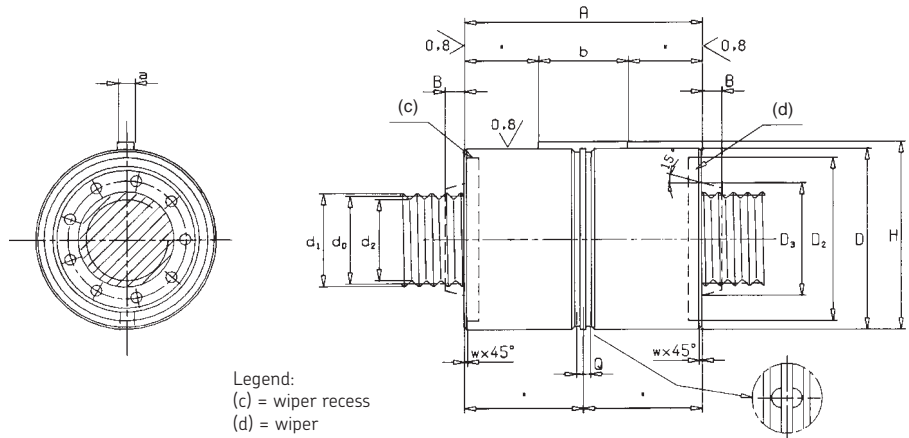

Designations	Dimensions										Basic load ratings		Preload torque		
	d_0	P_n	l_{tp}	d_1	d_2	D	A	a	b	H	Q	dynamic C_a	static C_{oa}	T_{pe}	T_{pr}
	mm										kN		Nm		
TRU 8×4	8	4	400	8.4	7.3	25	44	4	12	26.5	5	6.19	9.79	0.07	
PRU 8×4	8	4	400	8.4	7.3	25	44	4	12	26.5	5	6.19	9.79		0.06 - 0.13
TRU 12×5	12	5	600	12.4	11.3	30	44	4	12	31.5	5	9.77	13.36	0.13	
PRU 12×5	12	5	600	12.4	11.3	30	44	4	12	31.5	5	9.77	13.36		0.12 - 0.25
TRU 15×5	15	5	750	15.4	14.3	35	50	4	16	36.5	5	14.30	21.80	0.19	
PRU 15×5	15	5	750	15.4	14.3	35	50	4	16	36.5	5	14.30	21.80		0.18 - 0.36
TRU 15×8	15	8	750	15.5	14	35	50	4	16	36.5	5	15.11	20.39	0.19	
PRU 15×8	15	8	750	15.5	14	35	50	4	16	36.5	5	15.11	20.39		0.18 - 0.36
TRU 20×6	20	6	1050	20.4	19.3	40	50	4	16	41.5	5	14.78	22.43	0.30	
PRU 20×6	20	6	1050	20.4	19.3	40	50	4	16	41.5	5	14.78	22.43		0.26 - 0.58
TRU 21×5	21	5	1100	21.4	20.3	45	64	5	20	47.0	5	27.85	40.98	0.33	
PRU 21×5	21	5	1100	21.4	20.3	45	64	5	20	47.0	5	27.85	40.98		0.31 - 0.63
TRU 21×6	21	6	1100	21.4	20.3	45	64	5	20	47.0	5	29.08	41.09	0.33	
PRU 21×6	21	6	1100	21.4	20.3	45	64	5	20	47.0	5	29.08	41.09		0.31 - 0.63
TRU 21×8	21	8	1100	21.5	20	45	64	5	20	47.0	5	30.00	39.03	0.33	
PRU 21×8	21	8	1100	21.5	20	45	64	5	20	47.0	5	30.00	39.03		0.31 - 0.63
TRU 21×10	21	10	1100	21.8	19.7	45	64	5	20	47.0	5	32.64	41.51	0.33	
PRU 21×10	21	10	1100	21.8	19.7	45	64	5	20	47.0	5	32.64	41.51		0.31 - 0.63
TRU 24×6	24	6	1250	24.4	23.3	48	58	5	20	50.0	5	23.31	32.59	0.41	
PRU 24×6	24	6	1250	24.4	23.3	48	58	5	20	50.0	5	23.31	32.59		0.39 - 0.78
TRU 24×12	24	12	1250	24.8	22.7	48	58	5	20	50.0	5	26.25	31.17	0.41	
PRU 24×12	24	12	1250	24.8	22.7	48	58	5	20	50.0	5	26.25	31.17		0.39 - 0.78
TRU 25×5	25	5	1300	25.4	24.3	53	78	6	25	55.5	5	34.85	54.12	0.44	
PRU 25×5	25	5	1300	25.4	24.3	53	78	6	25	55.5	5	34.85	54.12		0.42 - 0.84
TRU 25×10	25	10	1300	25.8	23.7	53	78	6	25	55.5	5	40.02	52.65	0.44	
PRU 25×10	25	10	1300	25.8	23.7	53	78	6	25	55.5	5	40.02	52.65		0.42 - 0.84
TRU 25×15	25	15	1300	26.2	23.1	53	78	6	25	55.5	5	43.62	53.20	0.44	
PRU 25×15	25	15	1300	26.2	23.1	53	78	6	25	55.5	5	43.62	53.20		0.42 - 0.84
TRU 30×5	30	5	1600	30.4	29.3	64	85	6	32	66.5	5	50.68	89.16	0.59	
PRU 30×5	30	5	1600	30.4	29.3	64	85	6	32	66.5	5	50.68	89.16		0.57 - 1.13
TRU 30×6	30	6	1600	30.4	29.3	64	85	6	32	66.5	5	52.34	87.67	0.59	
PRU 30×6	30	6	1600	30.4	29.3	64	85	6	32	66.5	5	52.34	87.67		0.57 - 1.13
TRU 30×10	30	10	1600	30.8	28.7	64	85	6	32	66.5	5	58.58	87.18	0.59	
PRU 30×10	30	10	1600	30.8	28.7	64	85	6	32	66.5	5	58.58	87.18		0.57 - 1.13
TRU 30×20	30	20	1600	31.5	27.5	64	85	6	32	66.5	5	67.92	88.64	0.59	
PRU 30×20	30	20	1600	31.5	27.5	64	85	6	32	66.5	5	67.92	88.64		0.85 - 1.41

Continued

Symbols = see page 151

TRU / PRU - Range
(Continued)

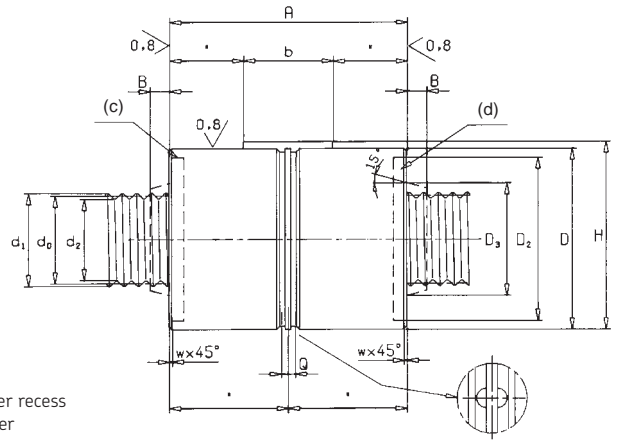
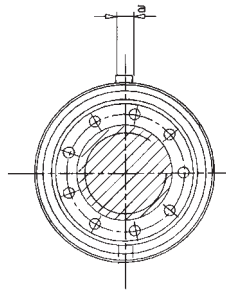

Legend:
(c) = wiper recess
(d) = wiper

3

Designations	Dimensions										Basic load ratings		Preload torque		
	d ₀	P _h	l _{tp}	d ₁	d ₂	D	A	a	b	H	Q	C _a	C _{oa}	T _{pe}	T _{pr}
	mm										kN		Nm		
TRU 36×6	36	6	1900	36.4	35.3	68	80	5	25	70.0	5	49.83	89.69	0.80	
PRU 36×6	36	6	1900	36.4	35.3	68	80	5	25	70.0	5	49.83	89.69		0.77 - 1.53
TRU 36×9	36	9	1900	36.5	35.1	68	80	5	25	70.0	5	53.73	87.03	0.80	
PRU 36×9	36	9	1900	36.5	35.1	68	80	5	25	70.0	5	53.73	87.03		0.77 - 1.53
TRU 36×12	36	12	1900	36.8	34.7	68	80	5	25	70.0	5	58.73	90.55	0.80	
PRU 36×12	36	12	1900	36.8	34.7	68	80	5	25	70.0	5	58.73	90.55		0.77 - 1.53
TRU 36×18	36	18	1900	37.2	34.1	68	80	5	25	70.0	5	62.89	88.29	0.80	
PRU 36×18	36	18	1900	37.2	34.1	68	80	5	25	70.0	5	62.89	88.29		0.77 - 1.53
TRU 36×24	36	24	1900	37.5	33.5	68	80	5	25	70.0	5	68.10	92.19	0.80	
PRU 36×24	36	24	1900	37.5	33.5	68	80	5	25	70.0	5	68.10	92.19		1.15 - 1.91
TRU 39×5	39	5	2100	39.4	38.3	80	100	8	40	83.0	7	71.19	134.46	0.92	
PRU 39×5	39	5	2100	39.4	38.3	80	100	8	40	83.0	7	71.19	134.46		0.88 - 1.75
TRU 39×10	39	10	2100	39.8	37.7	80	100	8	40	83.0	7	84.09	135.46	0.92	
PRU 39×10	39	10	2100	39.8	37.7	80	100	8	40	83.0	7	84.09	135.46		0.88 - 1.75
TRU 39×15	39	15	2100	40.2	37.1	80	100	8	40	83.0	7	92.36	136.45	0.92	
PRU 39×15	39	15	2100	40.2	37.1	80	100	8	40	83.0	7	92.36	136.45		0.88 - 1.75
TRU 39×20	39	20	2100	40.5	36.5	80	100	8	40	83.0	7	95.22	130.45	0.92	
PRU 39×20	39	20	2100	40.5	36.5	80	100	8	40	83.0	7	95.22	130.45		0.88 - 1.75
TRU 39×25	39	25	2100	40.9	35.9	80	100	8	40	83.0	7	96.30	124.50	0.92	
PRU 39×25	39	25	2100	40.9	35.9	80	100	8	40	83.0	7	96.30	124.50		1.31 - 2.19
TRU 44×8	44	8	2400	44.4	43.2	80	90	6	32	82.5	7	71.89	130.73	1.12	
PRU 44×8	44	8	2400	44.4	43.2	80	90	6	32	82.5	7	71.89	130.73		1.07 - 2.14
TRU 44×12	44	12	2400	44.8	42.7	80	90	6	32	82.5	7	79.18	131.44	1.12	
PRU 44×12	44	12	2400	44.8	42.7	80	90	6	32	82.5	7	79.18	131.44		1.07 - 2.14
TRU 44×18	44	18	2400	45.2	42.1	80	90	6	32	82.5	7	86.91	132.47	1.12	
PRU 44×18	44	18	2400	45.2	42.1	80	90	6	32	82.5	7	86.91	132.47		1.07 - 2.14
TRU 44×24	44	24	2400	45.5	41.5	80	90	6	32	82.5	7	92.46	133.48	1.12	
PRU 44×24	44	24	2400	45.5	41.5	80	90	6	32	82.5	7	92.46	133.48		1.07 - 2.14
TRU 44×30	44	30	2400	45.9	40.9	80	90	6	32	82.5	7	91.38	123.22	1.12	
PRU 44×30	44	30	2400	45.9	40.9	80	90	6	32	82.5	7	91.38	123.22		1.60 - 2.68

Continued

3 Driving systems
Roller screws

TRU / PRU - Range
(Continued)

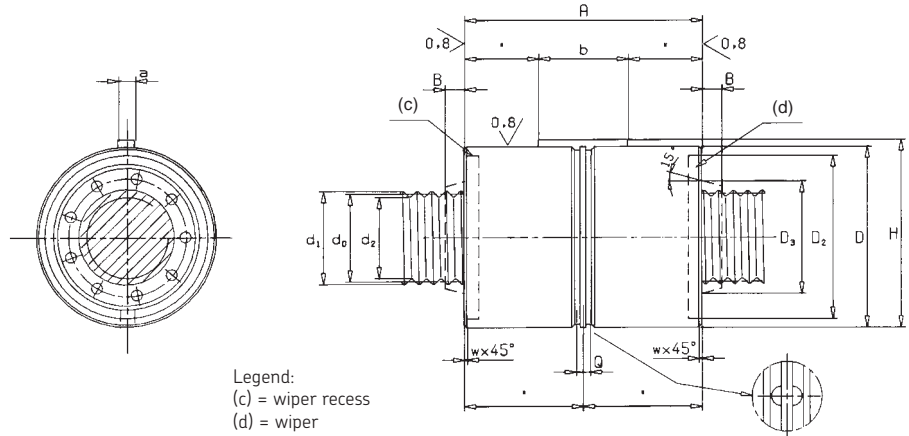

Continued

Designations	Dimensions											Basic load ratings		Preload torque	
	d_0	P_h	l_{tp}	d_1	d_2	D	A	a	b	H	Q	C_a	C_{oa}	T_{pe}	T_{pr}
	mm											kN		Nm	
TRU 48×5	48	5	2600	48.4	47.3	100	127	8	45	103.0	7	109.13	240.77	1.30	
PRU 48×5	48	5	2600	48.4	47.3	100	127	8	45	103.0	7	109.13	240.77		1.24 - 2.47
TRU 48×8	48	8	2600	48.6	47.1	100	127	8	45	103.0	7	120.34	235.30	1.30	
PRU 48×8	48	8	2600	48.6	47.1	100	127	8	45	103.0	7	120.34	235.30		1.24 - 2.47
TRU 48×10	48	10	2600	48.8	46.7	100	127	8	45	103.0	7	127.57	237.56	1.30	
PRU 48×10	48	10	2600	48.8	46.7	100	127	8	45	103.0	7	127.57	237.56		1.24 - 2.47
TRU 48×15	48	15	2600	49.2	46.1	100	127	8	45	103.0	7	142.01	243.18	1.30	
PRU 48×15	48	15	2600	49.2	46.1	100	127	8	45	103.0	7	142.01	243.18		1.24 - 2.47
TRU 48×20	48	20	2600	49.5	45.5	100	127	8	45	103.0	7	146.38	231.14	1.30	
PRU 48×20	48	20	2600	49.5	45.5	100	127	8	45	103.0	7	146.38	231.14		1.24 - 2.47
TRU 48×25	48	25	2600	49.9	44.9	100	127	8	45	103.0	7	157.50	245.52	1.30	
PRU 48×25	48	25	2600	49.9	44.9	100	127	8	45	103.0	7	157.50	245.52		1.24 - 2.47
TRU 56×12	56	12	3100	56.8	54.7	100	112	8	40	103.0	7	116.90	216.56	1.68	
PRU 56×12	56	12	3100	56.8	54.7	100	112	8	40	103.0	7	116.90	216.56		1.60 - 3.19
TRU 56×24	56	24	3100	57.5	53.5	100	112	8	40	103.0	7	133.45	209.58	1.68	
PRU 56×24	56	24	3100	57.5	53.5	100	112	8	40	103.0	7	133.45	209.58		1.60 - 3.19
TRU 56×36	56	36	3100	58.3	52.3	100	112	8	40	103.0	7	142.33	212.12	1.68	
PRU 56×36	56	36	3100	58.3	52.3	100	112	8	40	103.0	7	142.33	212.12		2.39 - 3.99
TRU 60×10	60	10	3400	60.8	58.7	122	152	10	45	125.0	10.5	186.53	389.85	1.88	
PRU 60×10	60	10	3400	60.8	58.7	122	152	10	45	125.0	10.5	186.53	389.85		1.79 - 3.58
TRU 60×15	60	15	3400	61.2	58.1	122	152	10	45	125.0	10.5	205.54	391.35	1.88	
PRU 60×15	60	15	3400	61.2	58.1	122	152	10	45	125.0	10.5	205.54	391.35		1.79 - 3.58
TRU 60×20	60	20	3400	61.5	57.5	122	152	10	45	125.0	10.5	217.61	392.83	1.88	
PRU 60×20	60	20	3400	61.5	57.5	122	152	10	45	125.0	10.5	217.61	392.83		1.79 - 3.58
TRU 64×12	64	12	3650	64.8	62.7	115	129	8	45	118.0	7	165.57	381.65	2.09	
PRU 64×12	64	12	3650	64.8	62.7	115	129	8	45	118.0	7	165.57	381.65		1.99 - 3.98
TRU 64×18	64	18	3650	65.2	62.1	115	129	8	45	118.0	7	176.93	362.78	2.09	
PRU 64×18	64	18	3650	65.2	62.1	115	129	8	45	118.0	7	176.93	362.78		1.99 - 3.98
TRU 64×24	64	24	3650	65.5	61.5	115	129	8	45	118.0	7	183.76	344.81	2.09	
PRU 64×24	64	24	3650	65.5	61.5	115	129	8	45	118.0	7	183.76	344.81		1.99 - 3.98
TRU 64×30	64	30	3650	65.9	60.9	115	129	8	45	118.0	7	177.73	309.92	2.09	
PRU 64×30	64	30	3650	65.9	60.9	115	129	8	45	118.0	7	177.73	309.92		1.99 - 3.98
TRU 64×36	64	36	3650	66.3	60.3	115	129	8	45	118.0	7	172.69	294.69	2.09	
PRU 64×36	64	36	3650	66.3	60.3	115	129	8	45	118.0	7	172.69	294.69		1.99 - 3.98

Symbols = see page 151

TRK / PRK - Range

Flanged nut with backlash elimination (TRK) or preloaded for optimum rigidity (PRK)

Legend:

- (a) = dowel pins to hold preload
- (b) = bolts for transport
- (c) = wiper recess
- (d) = wiper on request
- (e) = equidistant

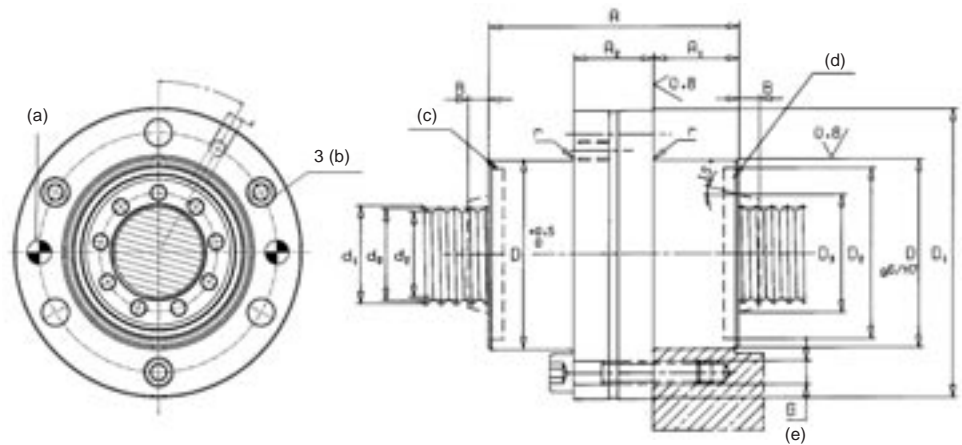

Designations	Dimensions											Basic load ratings		Preload torque		
	d_0	P_h	l_{tp}	d_1	d_2	D	A	D_1	J	G	Q	u	C_a	C_{oa}	T_{pe}	T_{pr}
	mm											[°]	kN	Nm		
TRK 8×4	8	4	400	8.4	7.3	25	44	46	36	6×M4	M6	30	6.19	9.79	0.07	
PRK 8×4	8	4	400	8.4	7.3	25	44	46	36	6×M4	M6	30	6.19	9.79		0.06 - 0.13
TRK 12×5	12	5	600	12.4	11.3	30	44	51	41	6×M4	M6	30	9.77	13.36	0.13	
PRK 12×5	12	5	600	12.4	11.3	30	44	51	41	6×M4	M6	30	9.77	13.36		0.12 - 0.25
TRK 15×5	15	5	750	15.4	14.3	35	50	58	46	6×M5	M6	30	14.30	21.80	0.19	
PRK 15×5	15	5	750	15.4	14.3	35	50	58	46	6×M5	M6	30	14.30	21.80		0.18 - 0.36
TRK 15×8	15	8	750	15.5	14	35	50	58	46	6×M5	M6	30	15.11	20.39	0.19	
PRK 15×8	15	8	750	15.5	14	35	50	58	46	6×M5	M6	30	15.11	20.39		0.18 - 0.36
TRK 20×6	20	6	1050	20.4	19.3	40	50	63	51	6×M5	M6	30	14.78	22.43	0.30	
PRK 20×6	20	6	1050	20.4	19.3	40	50	63	51	6×M5	M6	30	14.78	22.43		0.26 - 0.58
TRK 21×5	21	5	1100	21.0	20.3	45	64	68	56	6×M5	M6	30	27.85	40.98	0.33	
PRK 21×5	21	5	1100	21.0	20.3	45	64	68	56	6×M5	M6	30	27.85	40.98		0.31 - 0.63
TRK 21×6	21	6	1100	21.0	20.3	45	64	68	56	6×M5	M6	30	29.08	41.09	0.33	
PRK 21×6	21	6	1100	21.0	20.3	45	64	68	56	6×M5	M6	30	29.08	41.09		0.31 - 0.63
TRK 21×8	21	8	1100	21.0	20.0	45	64	68	56	6×M5	M6	30	30.00	39.03	0.33	
PRK 21×8	21	8	1100	21.0	20.0	45	64	68	56	6×M5	M6	30	30.00	39.03		0.31 - 0.63
TRK 21×10	21	10	1100	21.8	19.7	45	64	68	56	6×M5	M6	30	32.64	41.51	0.33	
PRK 21×10	21	10	1100	21.8	19.7	45	64	68	56	6×M5	M6	30	32.64	41.51		0.31 - 0.63
TRK 24×6	24	6	1250	24.4	23.3	48	58	71	59	6×M5	M6	30	23.31	32.59	0.41	
PRK 24×6	24	6	1250	24.4	23.3	48	58	71	59	6×M5	M6	30	23.31	32.59		0.39 - 0.78
TRK 24×12	24	12	1250	24.8	22.7	48	58	71	59	6×M5	M6	30	26.25	31.17	0.41	
PRK 24×12	24	12	1250	24.8	22.7	48	58	71	59	6×M5	M6	30	26.25	31.17		0.39 - 0.78
TRK 25×5	25	5	1300	25.4	24.3	56	78	84	70	6×M6	M6	30	34.85	54.12	0.44	
PRK 25×5	25	5	1300	25.4	24.3	56	78	84	70	6×M6	M6	30	34.85	54.12		0.42 - 0.84
TRK 25×10	25	10	1300	25.8	23.7	56	78	84	70	6×M6	M6	30	40.02	52.65	0.44	
PRK 25×10	25	10	1300	25.8	23.7	56	78	84	70	6×M6	M6	30	40.02	52.65		0.42 - 0.84
TRK 25×15	25	15	1300	26.2	23.1	56	78	84	70	6×M6	M6	30	43.62	53.20	0.44	
PRK 25×15	25	15	1300	26.2	23.1	56	78	84	70	6×M6	M6	30	43.62	53.20		0.42 - 0.84
TRK 30×5	30	5	1600	30.8	29.3	64	85	98	81	6×M8	M6	30	50.68	89.16	0.59	
PRK 30×5	30	5	1600	30.8	29.3	64	85	98	81	6×M8	M6	30	50.68	89.16		0.57 - 1.13
TRK 30×6	30	6	1600	30.4	29.3	64	85	98	81	6×M8	M6	30	52.34	87.67	0.59	
PRK 30×6	30	6	1600	30.4	29.3	64	85	98	81	6×M8	M6	30	52.34	87.67		0.57 - 1.13
TRK 30×10	30	10	1600	31.8	28.7	64	85	98	81	6×M8	M6	30	58.58	87.18	0.59	
PRK 30×10	30	10	1600	31.8	28.7	64	85	98	81	6×M8	M6	30	58.58	87.18		0.57 - 1.13
TRK 30×20	30	20	1600	31.5	27.5	64	85	98	81	6×M8	M6	30	67.92	88.64	0.59	
PRK 30×20	30	20	1600	31.5	27.5	64	85	98	81	6×M8	M6	30	67.92	88.64		0.85 - 1.41

Continued

Symbols = see page 151

3 Driving systems

Roller screws

TRK / PRK - Range (Continued)

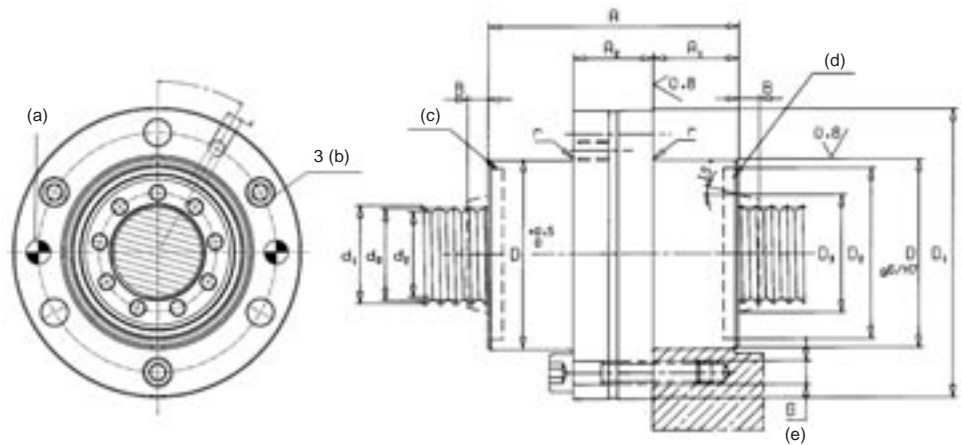

- Legend:
 (a) = dowel pins to hold preload
 (b) = bolts for transport
 (c) = wiper recess
 (d) = wiper on request
 (e) = equidistant

Symbols = see page 151

Continued

Designations	Dimensions												Basic load ratings		Preload torque	
	d_0	P_h	l_{tp}	d_1	d_2	D	A h12	D_1	J js12	G	Q	u	C_a	C_{oa}	T_{pe}	T_{pr}
	mm														Nm	
TRK 36×6	36	6	1900	36.4	35.3	68	80	102	85	6×M8	M6	30	49.83	89.69	0.80	
PRK 36×6	36	6	1900	36.4	35.3	68	80	102	85	6×M8	M6	30	49.83	89.69		0.77 - 1.53
TRK 36×9	36	9	1900	36.5	35.1	68	80	102	85	6×M8	M6	30	53.73	87.03	0.80	
PRK 36×9	36	9	1900	36.5	35.1	68	80	102	85	6×M8	M6	30	53.73	87.03		0.77 - 1.53
TRK 36×12	36	12	1900	36.8	34.7	68	80	102	85	6×M8	M6	30	58.73	90.55	0.80	
PRK 36×12	36	12	1900	36.8	34.7	68	80	102	85	6×M8	M6	30	58.73	90.55		0.77 - 1.53
TRK 36×18	36	18	1900	37.2	34.1	68	80	102	85	6×M8	M6	30	62.89	88.29	0.80	
PRK 36×18	36	18	1900	37.2	34.1	68	80	102	85	6×M8	M6	30	62.89	88.29		0.77 - 1.53
TRK 36×24	36	24	1900	37.5	33.5	68	80	102	85	6×M8	M6	30	68.10	92.19	0.80	
PRK 36×24	36	24	1900	37.5	33.5	68	80	102	85	6×M8	M6	30	68.10	92.19		1.15 - 1.91
TRK 39×5	39	5	2100	39.4	38.3	82	100	124	102	6×M10	M6	30	71.19	134.46	0.92	
PRK 39×5	39	5	2100	39.4	38.3	82	100	124	102	6×M10	M6	30	71.19	134.46		0.88 - 1.75
TRK 39×10	39	10	2100	39.8	37.7	82	100	124	102	6×M10	M6	30	84.09	135.46	0.92	
PRK 39×10	39	10	2100	39.8	37.7	82	100	124	102	6×M10	M6	30	84.09	135.46		0.88 - 1.75
TRK 39×15	39	15	2100	40.2	37.1	82	100	124	102	6×M10	M6	30	92.36	136.45	0.92	
PRK 39×15	39	15	2100	40.2	37.1	82	100	124	102	6×M10	M6	30	92.36	136.45		0.88 - 1.75
TRK 39×20	39	20	2100	40.5	36.5	82	100	124	102	6×M10	M6	30	95.22	130.45	0.92	
PRK 39×20	39	20	2100	40.5	36.5	82	100	124	102	6×M10	M6	30	95.22	130.45		0.88 - 1.75
TRK 39×25	39	25	2100	40.9	35.9	82	100	124	102	6×M10	M6	30	96.30	124.50	0.92	
PRK 39×25	39	25	2100	40.9	35.9	82	100	124	102	6×M10	M6	30	96.30	124.50		1.31 - 2.19
TRK 44×8	44	8	2400	44.4	43.2	82	90	124	102	6×M10	M6	30	71.89	130.73	1.12	
PRK 44×8	44	8	2400	44.4	43.2	82	90	124	102	6×M10	M6	30	71.89	130.73		1.07 - 2.14
TRK 44×12	44	12	2400	44.8	42.7	82	90	124	102	6×M10	M6	30	79.18	131.44	1.12	
PRK 44×12	44	12	2400	44.8	42.7	82	90	124	102	6×M10	M6	30	79.18	131.44		1.07 - 2.14
TRK 44×18	44	18	2400	45.2	42.1	82	90	124	102	6×M10	M6	30	86.91	132.47	1.12	
PRK 44×18	44	18	2400	45.2	42.1	82	90	124	102	6×M10	M6	30	86.91	132.47		1.07 - 2.14
TRK 44×24	44	24	2400	45.5	41.5	82	90	124	102	6×M10	M6	30	92.46	133.48	1.12	
PRK 44×24	44	24	2400	45.5	41.5	82	90	124	102	6×M10	M6	30	92.46	133.48		1.07 - 2.14
TRK 44×30	44	30	2400	45.9	40.9	82	90	124	102	6×M10	M6	30	91.38	123.22	1.12	
PRK 44×30	44	30	2400	45.9	40.9	82	90	124	102	6×M10	M6	30	91.38	123.22		1.60 - 2.68

Continued

TRK / PRK - Range
(Continued)

- Legend:
 (a) = dowel pins to hold preload
 (b) = bolts for transport
 (c) = wiper recess
 (d) = wiper on request
 (e) = equidistant

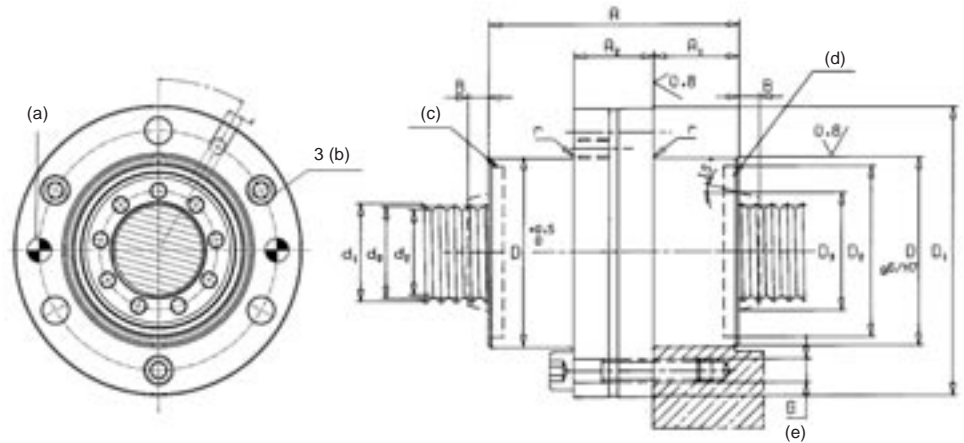

Continued

Designations	Dimensions												Basic load ratings		Preload torque	
	d_0	P_h	l_{tp}	d_1	d_2	D	A	D_1	J	G	Q	u	C_a	C_{oa}	T_{pe}	T_{pr}
	mm												kN		Nm	
TRK 48×5	48	5	2600	48.4	47.3	105	127	150	127	6×M12	M8×1	30	109.13	240.77	1.30	
PRK 48×5	48	5	2600	48.4	47.3	105	127	150	127	6×M12	M8×1	30	109.13	240.77		1.24 - 2.47
TRK 48×8	48	8	2600	48.6	47.1	105	127	150	127	6×M12	M8×1	30	120.34	235.30	1.30	
PRK 48×8	48	8	2600	48.6	47.1	105	127	150	127	6×M12	M8×1	30	120.34	235.30		1.24 - 2.47
TRK 48×10	48	10	2600	48.8	46.7	105	127	150	127	6×M12	M8×1	30	127.57	237.56	1.30	
PRK 48×10	48	10	2600	48.8	46.7	105	127	150	127	6×M12	M8×1	30	127.57	237.56		1.24 - 2.47
TRK 48×15	48	15	2600	49.2	46.1	105	127	150	127	6×M12	M8×1	30	142.01	243.18	1.30	
PRK 48×15	48	15	2600	49.2	46.1	105	127	150	127	6×M12	M8×1	30	142.01	243.18		1.24 - 2.47
TRK 48×20	48	20	2600	49.5	45.5	105	127	150	127	6×M12	M8×1	30	146.38	231.14	1.30	
PRK 48×20	48	20	2600	49.5	45.5	105	127	150	127	6×M12	M8×1	30	146.38	231.14		1.24 - 2.47
TRK 48×25	48	25	2600	49.9	44.9	105	127	150	127	6×M12	M8×1	30	157.50	245.52	1.30	
PRK 48×25	48	25	2600	49.9	44.9	105	127	150	127	6×M12	M8×1	30	157.50	245.52		1.24 - 2.47
TRK 56×12	56	12	3100	56.8	54.7	105	112	150	127	6×M12	M8×1	30	116.90	216.56	1.68	
PRK 56×12	56	12	3100	56.8	54.7	105	112	150	127	6×M12	M8×1	30	116.90	216.56		1.60 - 3.19
TRK 56×24	56	24	3100	57.5	53.5	105	112	150	127	6×M12	M8×1	30	133.45	209.58	1.68	
PRK 56×24	56	24	3100	57.5	53.5	105	112	150	127	6×M12	M8×1	30	133.45	209.58		1.60 - 3.19
TRK 56×36	56	36	3100	58.3	52.3	105	112	150	127	6×M12	M8×1	30	142.33	212.12	1.68	
PRK 56×36	56	36	3100	58.3	52.3	105	112	150	127	6×M12	M8×1	30	142.33	212.12		2.39 - 3.99
TRK 60×10	60	10	3400	60.8	58.7	122	152	180	150	6×M16	M8×1	30	186.53	389.85	1.88	
PRK 60×10	60	10	3400	60.8	58.7	122	152	180	150	6×M16	M8×1	30	186.53	389.85		1.79 - 3.58
TRK 60×15	60	15	3400	61.2	58.1	122	152	180	150	6×M16	M8×1	30	205.54	391.35	1.88	
PRK 60×15	60	15	3400	61.2	58.1	122	152	180	150	6×M16	M8×1	30	205.54	391.35		1.79 - 3.58
TRK 60×20	60	20	3400	61.5	57.5	122	152	180	150	6×M16	M8×1	30	217.61	392.83	1.88	
PRK 60×20	60	20	3400	61.5	57.5	122	152	180	150	6×M16	M8×1	30	217.61	392.83		1.79 - 3.58
TRK 64×12	64	12	3650	64.8	62.7	120	129	180	150	6×M16	M8×1	30	165.57	381.65	2.09	
PRK 64×12	64	12	3650	64.8	62.7	120	129	180	150	6×M16	M8×1	30	165.57	381.65		1.99 - 3.98
TRK 64×18	64	18	3650	65.2	62.1	120	129	180	150	6×M16	M8×1	30	176.93	362.78	2.09	
PRK 64×18	64	18	3650	65.2	62.1	120	129	180	150	6×M16	M8×1	30	176.93	362.78		1.99 - 3.98
TRK 64×24	64	24	3650	65.5	61.5	120	129	180	150	6×M16	M8×1	30	183.76	344.81	2.09	
PRK 64×24	64	24	3650	65.5	61.5	120	129	180	150	6×M16	M8×1	30	183.76	344.81		1.99 - 3.98
TRK 64×30	64	30	3650	65.9	60.9	120	129	180	150	6×M16	M8×1	30	177.73	309.92	2.09	
PRK 64×30	64	30	3650	65.9	60.9	120	129	180	150	6×M16	M8×1	30	177.73	309.92		1.99 - 3.98
TRK 64×36	64	36	3650	66.3	60.3	120	129	180	150	6×M16	M8×1	30	172.69	294.69	2.09	
PRK 64×36	64	36	3650	66.3	60.3	120	129	180	150	6×M16	M8×1	30	172.69	294.69		1.99 - 3.98

3 Driving systems

Roller screws

Recirculating roller screws

BVC - Range

Legend:
 (a) = key
 (b) = no wiper
 (c) = lubrication

Maximum threaded length: Can be cut and machined to customer requirements

Screw ends can be machined to customer requirements

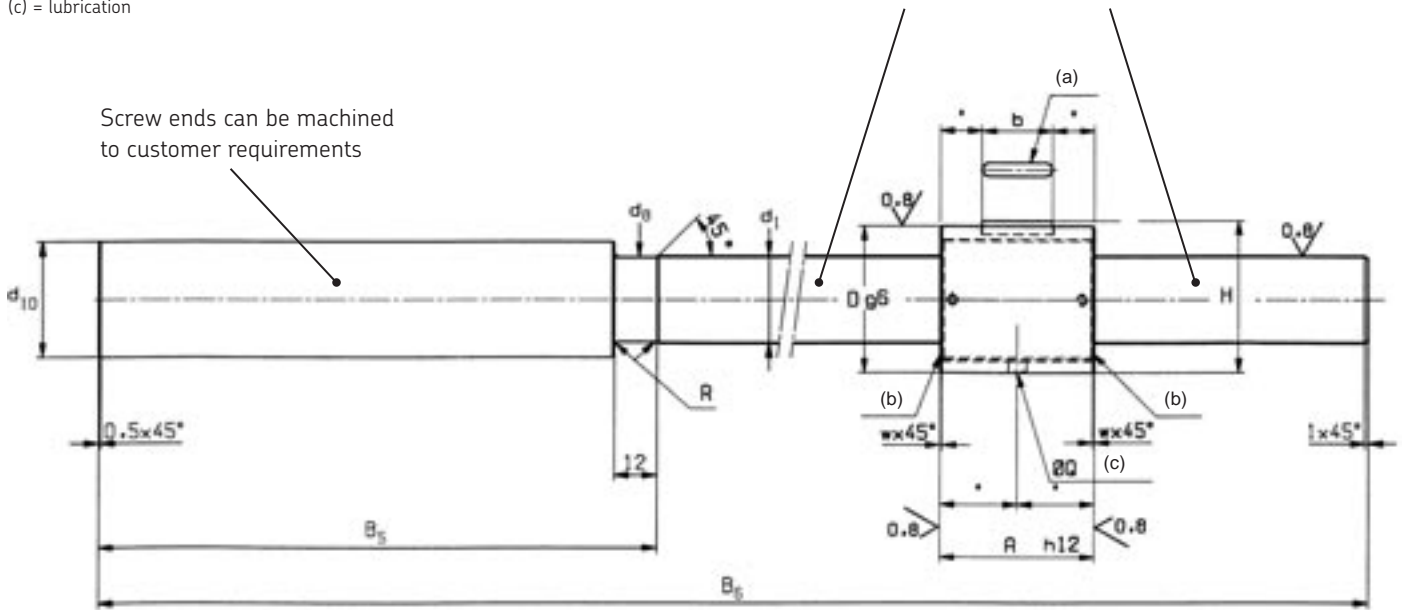

Recirculating roller screws without end machining, lead precision G5 according to ISO standard. Nut preloaded by rollers for backlash elimination.

Designations	Dimensions						Basic load ratings	
	d_0	B_6	d_{10}	B_5	D	A	dynamic C_a	static C_{0a}
	mm						kN	
BVC 20×1-R1	20	400	28	116	34	37	18.5	36.6
BVC 25×1-R1	25	500	33	159	42	44	32.9	68.4
BVC 32×1-R1	32	500	40	179	54	57	64.3	159.2

FLRBU / BVC

Recirculating roller screw with thrust bearing unit

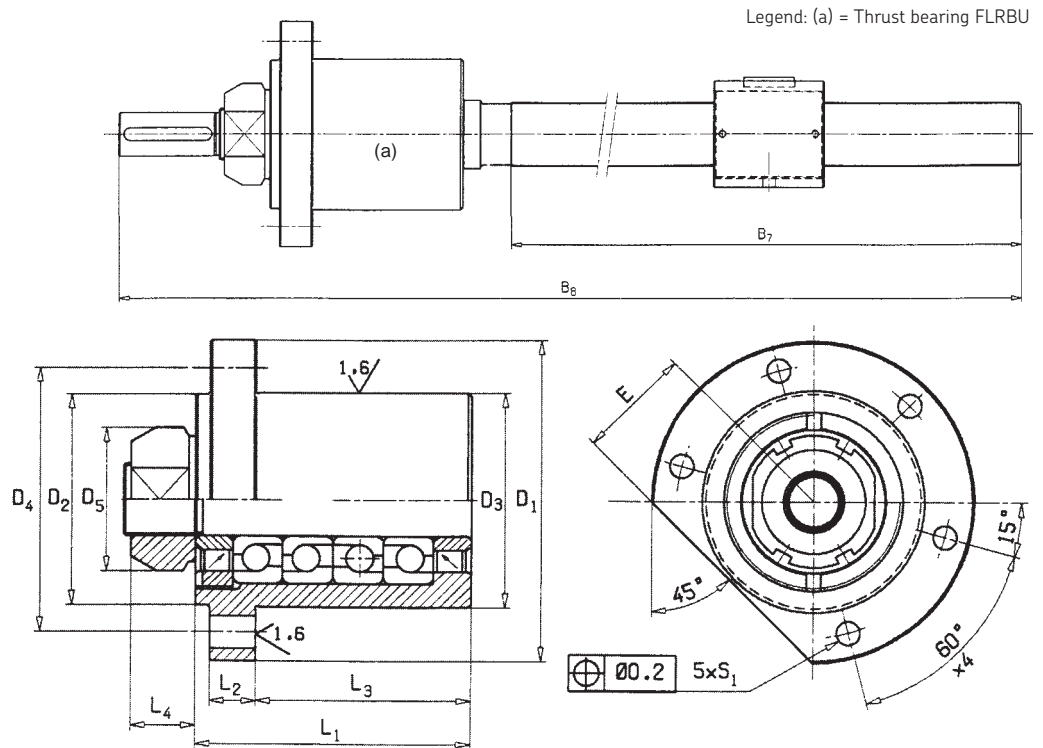

Designations	Dimensions										Basic load ratings	
	d ₀	B ₇	B ₈	L ₁	L ₂	L ₃	D ₁	D ₃	D ₄	E	dynamic C _a	static C _{0a}
	mm										kN	
FLRBU2 / BVC 20×1-R1	20	284	397	46	10	32	90	60	76	32	27.9	31.9
FLRBU3 / BVC 25×1-R1	25	341	497	77	13	60	90	60	74	32	40.1	63.8
FLRBU4 / BVC 32×1-R1	32	321	497	89	16	68	120	80	100	44	74.2	119.2

3 Driving systems

Roller screws

SVC - Range

Cylindrical nut with axial play, nut without wiper recesses

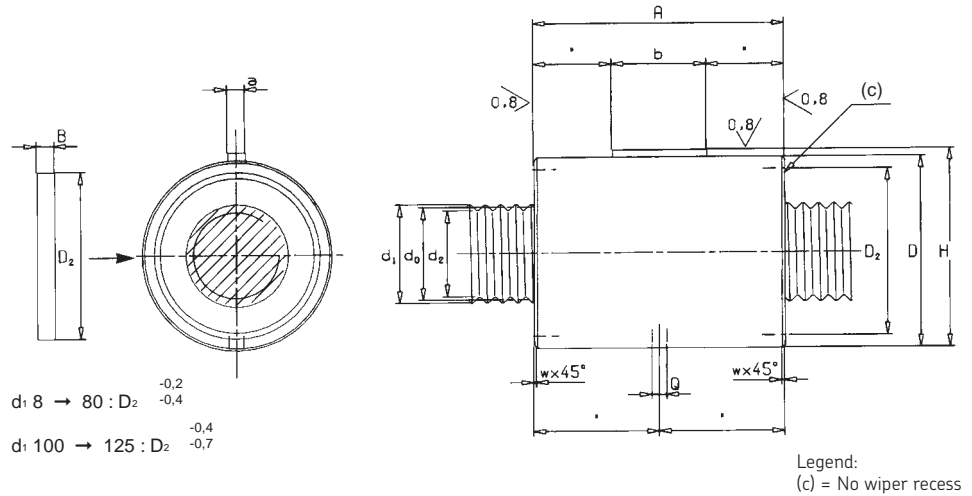

Designations	Dimensions										Basic load ratings			
	d_1	P_h	l_{tp}	s_{ap}	d_0	d_2	D	A	a	b	H	Q	C_a	C_{0a}
	mm										kN			
SVC 8×1	8	1	500	0.02	7.7	7.1	20	31	2	12	20.8	5	8.4	11.0
SVC 10×1	10	1	650	0.02	9.7	9.1	22	31	2	12	22.8	5	8.9	11.4
SVC 10×2	10	2	650	0.02	9.7	9.1	22	31	2	12	22.8	5	8.9	11.4
SVC 12×1	12	1	750	0.02	11.7	11.1	24	31	2	12	24.8	5	10.3	14.0
SVC 12×2	12	2	750	0.02	11.7	11.1	24	31	2	12	24.8	5	10.3	14.0
SVC 16×1	16	1	1050	0.02	15.7	15.1	29	31	3	12	30.2	5	11.5	16.8
SVC 16×2	16	2	1050	0.02	15.7	15.1	29	31	3	12	30.2	5	11.5	16.8
SVC 20×1	20	1	1300	0.02	19.7	19.1	34	37	3	16	35.2	5	18.5	36.6
SVC 20×2	20	2	1300	0.02	19.7	19.1	34	37	3	16	35.2	5	18.5	36.6
SVC 25×1	25	1	1650	0.02	24.7	24.1	42	44	4	20	43.5	5	32.9	68.4
SVC 25×2	25	2	1650	0.02	24.7	24.1	42	44	4	20	43.5	5	32.9	68.4
SVC 32×1	32	1	2150	0.02	31.7	31.1	54	57	4	25	55.5	5	64.3	159.2
SVC 32×2	32	2	2150	0.02	31.7	31.1	54	57	4	25	55.5	5	64.3	159.2
SVC 40×1	40	1	2700	0.02	39.7	39.1	68	63	5	32	70.0	5	79.1	231.6
SVC 40×2	40	2	2700	0.04	39.3	38.2	68	72	5	32	70.0	5	49.9	117.2
SVC 50×1	50	1	3500	0.02	49.7	49.1	82	85	6	32	84.5	8	189.8	544.3
SVC 50×2	50	2	3500	0.04	49.3	48.7	82	85	6	32	84.5	8	98.1	249.4
SVC 50×3	50	3	3500	0.04	49.5	48.6	82	92	6	35	84.5	8	153.0	443.3
SVC 50×4	50	4	3500	0.04	49.3	48.2	82	85	6	32	84.5	8	98.1	249.4
SVC 63×2	63	2	4500	0.04	62.3	61.2	103	104	6	40	105.5	8	185.8	533.5
SVC 63×4	63	4	4500	0.04	62.3	61.2	103	104	6	40	105.5	8	185.8	533.5
SVC 80×4	80	4	6000	0.07	78.6	76.4	141	175	8	63	144.0	10	324.9	887.7
SVC 100×5	100	5	8000	0.07	98.3	95.5	175	205	10	80	178.0	10	468.5	1376.3
SVC 125×5	125	5	8000	0.07	123.3	120.5	220	250	12	100	223.0	12	756.0	2270.0

Symbols = see page 151

PVU - Range

Cylindrical nut, preloaded for optimum rigidity, nut without wiper recesses

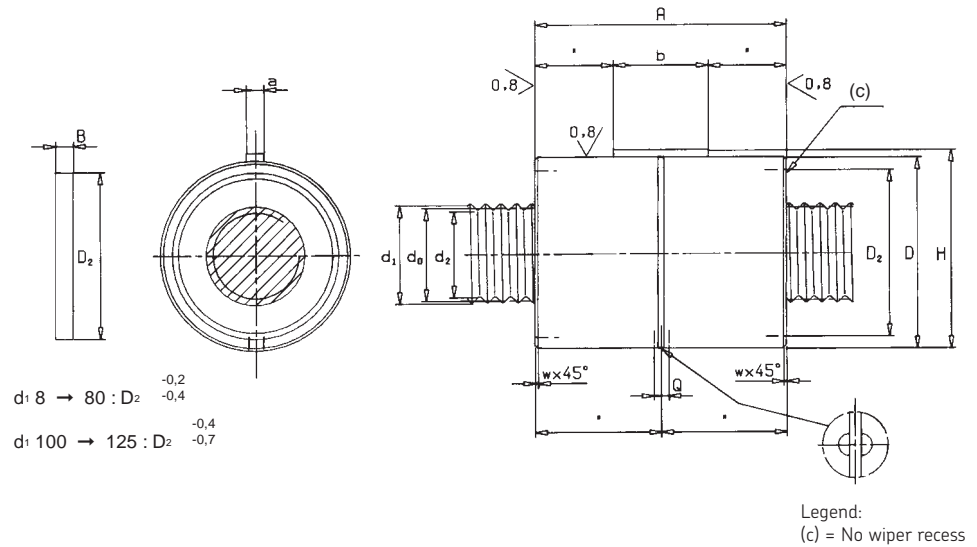

Designations	Dimensions										Basic load ratings		Preload torque T_{pr}
	d_1	p_h	l_{tp}	d_0	d_2	D g6/H7	A h12	a h9	b	Q	C_a dynamic	C_{oa} static	
mm											kN		Nm
PVU 8×1	8	1	400	7.7	7.1	20	31	2	12	5	4.8	5.5	0.02-0.08
PVU 10×1	10	1	500	9.7	9.1	22	31	2	12	5	5.1	5.7	0.03-0.10
PVU 10×2	10	2	500	9.7	9.1	22	31	2	12	5	5.1	5.7	0.03-0.10
PVU 12×1	12	1	600	11.7	11.1	24	31	2	12	5	5.9	7.0	0.05-0.15
PVU 12×2	12	2	600	11.7	11.1	24	31	2	12	5	5.9	7.0	0.05-0.15
PVU 16×1	16	1	825	15.7	15.1	29	31	3	12	5	6.6	8.4	0.10-0.20
PVU 16×2	16	2	825	15.7	15.1	29	31	3	12	5	6.6	8.4	0.10-0.20
PVU 20×1	20	1	1050	19.7	19.1	34	37	3	16	5	10.6	18.3	0.18-0.32
PVU 20×2	20	2	1050	19.7	19.1	34	37	3	16	5	10.6	18.3	0.20-0.35
PVU 25×1	25	1	1300	24.7	24.1	42	44	4	20	5	18.9	34.2	0.35-0.65
PVU 25×2	25	2	1300	24.7	24.1	42	44	4	20	5	18.9	34.2	0.40-0.70
PVU 32×1	32	1	1700	31.7	31.1	54	57	4	25	5	36.9	79.6	0.50-0.95
PVU 32×2	32	2	1700	31.7	31.1	54	57	4	25	5	36.9	79.6	0.50-0.95
PVU 40×1	40	1	2150	39.7	39.1	68	63	5	32	5	45.4	115.8	0.70-1.40
PVU 40×2	40	2	2150	39.3	38.2	68	72	5	32	5	28.7	58.6	0.70-1.40
PVU 50×1	50	1	2800	49.7	49.1	82	85	6	32	8	109.0	272.2	1.20-2.50
PVU 50×2	50	2	2800	49.3	48.7	82	85	6	32	8	56.3	124.7	1.20-2.50
PVU 50×3	50	3	2800	49.5	48.6	82	92	6	35	8	88.0	221.7	1.20-2.50
PVU 50×4	50	4	2800	49.3	48.2	82	85	6	32	8	56.3	124.7	1.20-2.50
PVU 63×2	63	2	3600	62.3	61.2	103	104	6	40	8	106.7	266.8	1.80-3.20
PVU 63×4	63	4	3600	62.3	61.2	103	104	6	40	8	106.7	266.8	2.00-3.50
PVU 80×4	80	4	4000	78.6	76.4	141	175	8	63	10	186.6	443.9	3.00-5.50
PVU 100×5	100	5	4000	98.4	95.5	175	205	10	80	10	269.1	688.2	4.50-7.50
PVU 125×5	125	5	4000	123.3	120.5	220	250	12	100	12	434.0	1385.0	7.00-10.00

Symbols = see page 151

3 Driving systems

Roller screws

PVK - Range

Flanged nut, preloaded for optimum rigidity,
nut without wiper recesses

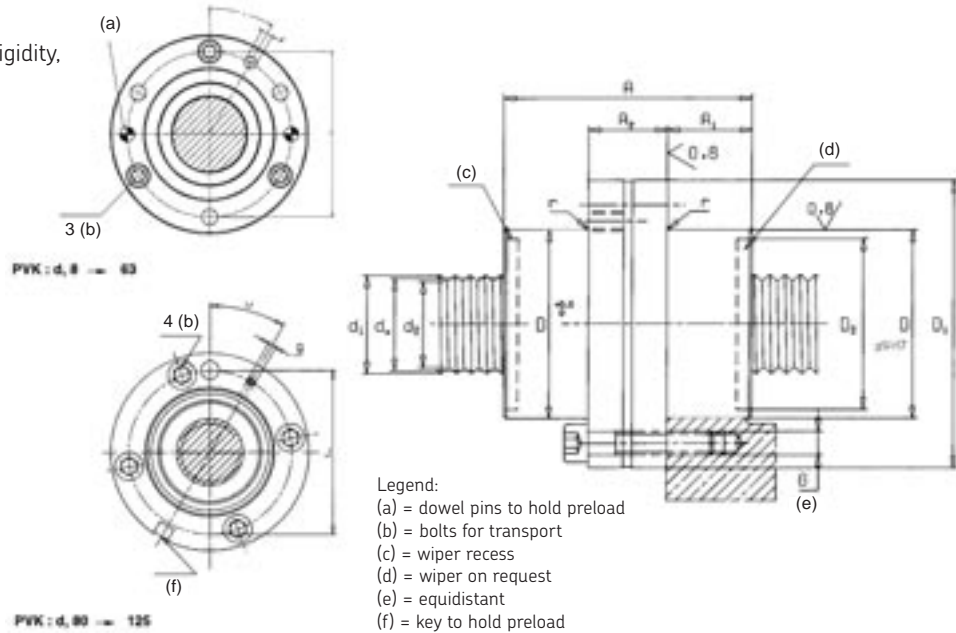

Symbols = see page 151

Designations	Dimensions												Basic load ratings		Preload torque	
	d ₁	P _h	l _{tp}	d ₀	d ₂	D	A	D ₁	J	G	Q	u	C _a	C _{oa}	T _{pr}	
	mm															
													[°]	kN		Nm
PVK 8×1	8	1	400	7.7	7.1	22	40	43	33	6×M4	M6	30	4.8	5.5	0.02 - 0.08	
PVK 10×1	10	1	500	9.7	9.1	22	40	43	33	6×M4	M6	30	5.1	5.7	0.03 - 0.10	
PVK 10×2	10	2	500	9.7	9.1	22	40	43	33	6×M4	M6	30	5.1	5.7	0.03 - 0.10	
PVK 12×1	12	1	600	11.7	11.1	25	40	46	36	6×M4	M6	30	5.9	7.0	0.05 - 0.15	
PVK 12×2	12	2	600	11.7	11.1	25	40	46	36	6×M4	M6	30	5.9	7.0	0.05 - 0.15	
PVK 16×1	16	1	825	15.7	15.1	30	40	51	41	6×M4	M6	30	6.6	8.4	0.10 - 0.20	
PVK 16×2	16	2	825	15.7	15.1	30	40	51	41	6×M4	M6	30	6.6	8.4	0.10 - 0.20	
PVK 20×1	20	1	1050	19.7	19.1	35	45	58	46	6×M5	M6	30	10.6	18.3	0.18 - 0.32	
PVK 20×2	20	2	1050	19.7	19.1	35	45	58	46	6×M5	M6	30	10.6	18.3	0.20 - 0.35	
PVK 25×1	25	1	1300	24.7	24.1	45	54	68	56	6×M5	M6	30	18.9	34.2	0.35 - 0.65	
PVK 25×2	25	2	1300	24.7	24.1	45	54	68	56	6×M5	M6	30	18.9	34.2	0.40 - 0.70	
PVK 32×1	32	1	1700	31.7	31.1	56	67	84	70	6×M6	M6	30	36.9	79.6	0.50 - 0.95	
PVK 32×2	32	2	1700	31.7	31.1	56	67	84	70	6×M6	M6	30	36.9	79.6	0.50 - 0.95	
PVK 40×1	40	1	2150	39.7	39.1	68	75	102	85	6×M8	M6	30	45.4	115.8	0.70 - 1.40	
PVK 40×2	40	2	2150	39.3	38.2	68	84	102	85	6×M8	M6	30	28.7	58.6	0.70 - 1.40	
PVK 50×1	50	1	2800	49.7	49.1	82	101	124	102	6×M10	M6	30	109.0	272.2	1.20 - 2.50	
PVK 50×2	50	2	2800	49.3	48.7	82	101	124	102	6×M10	M6	30	56.3	124.7	1.20 - 2.50	
PVK 50×3	50	3	2800	49.5	48.6	82	108	124	102	6×M10	M6	30	88.0	221.7	1.20 - 2.50	
PVK 50×4	50	4	2800	49.3	48.2	82	101	124	102	6×M10	M6	30	56.3	124.7	1.20 - 2.50	
PVK 63×2	63	2	3600	62.3	61.2	105	120	150	127	6×M12	M8×1	30	106.7	266.8	1.80 - 3.20	
PVK 63×4	63	4	3600	62.3	61.2	105	120	150	127	6×M12	M8×1	30	106.7	266.8	2.00 - 3.50	
PVK 80×4	80	4	4000	78.6	76.4	140	197	200	170	8×M16	M8×1	22°30	186.6	443.9	3.00 - 5.50	
PVK 100×5	100	5	4000	98.4	95.5	180	237	240	210	10×M16	M8×1	15	269.1	688.2	4.50 - 7.50	
PVK 125×5	125	5	4000	123.3	120.5	220	282	310	270	12×M18	M8×1	15	434.0	1385.0	7.00 - 10.0	

FLRBU - Accessories for roller screws

Accessories for screw shaft, flanged thrust bearing units: FLRBU

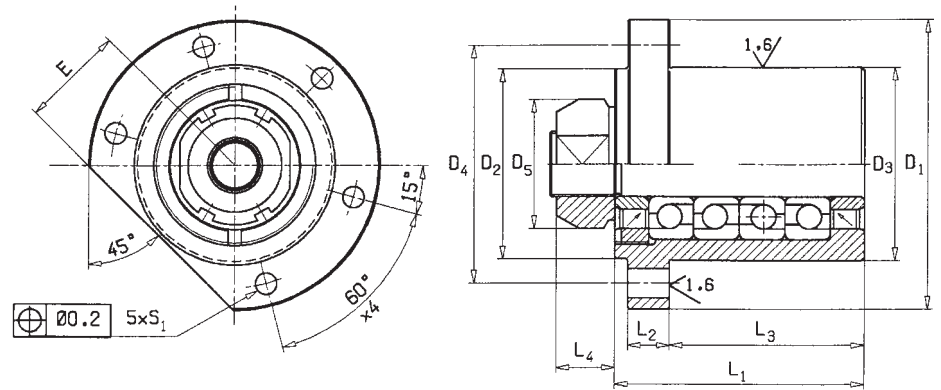

Designations	Dimensions										Attachment screw	Angular contact E	Basic load ratings		Max preload torque at 50 rpm	Axial rigidity	Tilt rigidity
	L ₁	L ₂	L ₃	L ₄	D ₁	D ₂	D ₃ h7	D ₄	D ₅	S ₁ H13			C _a	C _{oa}			
mm													kN	Nm	N/μm	Nm/mrad	
FLRBU1	42	10	25	14	76	50	47	63	30	6.6	M6×25	27	13.3	14.7	0.1	150	40
FLRBU2	46	10	32	18	90	62	60	76	37	6.6	M6×25	32	27.9	31.9	0.25	190	51
FLRBU3	77	13	60	18	90	59	60	74	40	9.0	M8×25	32	40.1	63.8	0.25	400	140
FLRBU4	89	16	68	20	120	80	80	100	44	11.0	M10×30	44	74.2	119.2	1.1	450	160
FLRBU5	110	20	82	22	140	99	100	120	54	13.0	M12×40	54	109.4	188.4	1.1	600	715
FLRBU6	140	25	98.5	25	171	130	130	152	75	13.0	M12×40	67	208.8	392.3	1.5	750	1000
FLRBU7	180	30	133.5	28	225	170	170	198	95	17.5	M16×55	87	305.3	615.4	2	1250	1600

Flanged bearing unit designations	Bearing designations	Quantity of bearings
FLRBU1	7201 BEGBP	2
FLRBU2	7303 BEGBP	2
FLRBU3	7204 BEGBP	4
FLRBU4	7305 BEGBP	4
FLRBU5	7307 BEGBP	4
FLRBU6	7310 BEGBP	4
FLRBU7	7313 BEGBP	4

Symbols = see page 151

3 Driving systems

Roller screws

Thrust bearing units for the standard roller screw range

Flanged thrust bearing	Suitable for SRC & SRF	Suitable for PRU & PRK
FLRBU1	SR 8×4 - R4	PR 8×4 - R4 PR 12×5 - R5 PR 15×5 - R5 - PR 15×8 - R5
FLRBU2	SR 12×5 - R5 SR 15×5 - R5 - SR 15×8 - R5 SR 20×6 - R6	PR 20×6 - R6 PR 21×5 - R5 - PR 21×6 - R5 - PR 21×8 - R5 PR 24×6 - R6 - PR 24×12 - R6
FLRBU3	SR 24×6 - R6	PR 21×10 - R5 PR 25×5 - R5 - PR 25×10 - R5 - PR 25×15 - R5
FLRBU4	SR 21×5 - R5 - SR 21×6 - R5 - SR 21×8 - R5 SR 21×10 - R5 SR 24×12 - R6 SR 25×5 - R5 - SR 25×10 - R5 - SR 25×15 - R5	PR 30×5 - R5 - PR 30×6 - R5 - PR 30×10 - R5 PR 30×20 - R5 PR 36×6 - R6 - PR 36×9 - R6 - PR 36×12 - R6 PR 36×18 - R6 - PR 36×24 - R6 PR 39×5 - R5 PR 44×8 - R6 - PR 44×12 - R6
FLRBU5	SR 30×5 - R5 - SR 30×6 - R5 - SR 30×10 - R5 SR 36×6 - R6 - SR 36×9 - R6 - SR 36×12 - R6 SR 36×18 - R6	PR 39×10 - R5 - PR 39×15 - R5 - PR 39×20 - R5 PR 39×25 - R5 PR 44×18 - R6 - PR 44×24 - R6 - PR 44×30 - R6 PR 48×5 - R5 - PR 48×8 - R5 PR 56×12 - R6
FLRBU6	SR 30×20 - R5 SR 36×24 - R6 SR 39×5 - R5 - SR 39×10 - R5 - SR 39×15 - R5 SR 39×20 - R5 - SR 39×25 - R5 SR 44×8 - R6 - SR 44×12 - R6 - SR 44×18 - R6 SR 44×24 - R6 - SR 44×30 - R6 SR 48×5 - R5 - SR 48×8 - R5 - SR 48×10 - R5 SR 48×15 - R5 SR 56×12 - R6	PR 48×10 - R5 - PR 48×15 - R5 - PR 48×20 - R5 PR 48×25 - R5 PR 56×24 - R6 - PR 56×36 - R6 PR 60×10 - R5 - PR 60×15 - R5 - PR 60×20 - R5 PR 64×12 - R6 - PR 64×18 - R6 - PR 64×24 - R6 PR 64×30 - R6 - PR 64×36 - R6
FLRBU7	SR 48×15 - R5 - SR 48×20 - R5 - SR 48×25 - R5 SR 56×24 - R6 - SR 56×36 - R6 SR 64×12 - R6 - SR 64×18 - R6 - SR 64×24 - R6 SR 64×30 - R6 - SR 64×36 - R6	

Flanged thrust bearing	Suitable for SVC	Suitable for PVU & PVK
FLRBU1	SV 8×1 - R1 - SV 8×2 - R2 SV 10×1 - R1 - SV 10×2 - R2 SV 12×1 - R1 - SV 12×2 - R2 SV 16×1 - R1 - SV 16×2 - R2	PV 8×1 - R1 - PV 10×1 - R1 PV 12×1 - R1 - PV 16×1 - R1 PV 16×2 - R1 - PV 20×1 - R1
FLRBU2	SV 20×1 - R1 and SV 20×2 - R2	PV 25×1 - R1 - PV 25×2 - R2
FLRBU3	SV 25×1 - R1 - SV 25×2 - R2	PV 32×1 - R1 - PV 32×2 - R2 PV 40×2 - R1
FLRBU4	SV 32×1 - R1 - SV 32×2 - R2 SV 40×2 - R1	PV 40×1 - R1 PV 50×2 - R1 - PV 50×4 - R2
FLRBU5	SV 40×1 - R1 SV 50×2 - R1 - SV 50×4 - R2	PV 50×1 - R1 - PV 50×3 - R2 PV 63×2 - R1 - PV 63×4 - R2
FLRBU6	SV 50×1 - R1 - SV 50×3 - R2 SV 63×2 - R1 - SV 63×4 - R2	PV 80×4 - R1
FLRBU7	SV 80×4 - R1	PV 100×5 - R1

Symbols

C_{req}	N	Required load rating	d_o	mm	Nominal	
C_a	kN	The dynamic load rating (L_{10} life) is such that 90% of a sufficiently large sample of identical screws can be expected to attain or exceed 1 million revolutions under this constant and centrally acting pure axial load without fatigue (flaking).	d_1	mm	Outside	
			d_2	mm	Root	
			d_b	mm	Bore	
			e_p	μm	Tolerance of actual mean travel, l_m relative to specified travel l_s	
			f	-	Factors	
C_{oa}	kN	The static load rating is that axial constant centrally acting load which produces a total permanent deformation of one raceway and roller of 0,0001 of the diameter of the curved surface of the roller.	g	m/s^2	Acceleration of gravity: 9,8	
F	N	Axial load	l	mm	Length	
F_c	N	Compression load	l_o	mm	Nominal travel – the nominal lead multiplied by the number of revolutions	
F_m	N	Constant mean axial load	l_1	mm	Threaded length	
F_{pr}	N	The preload force between a nut half (or nut) and the shaft	l_e	mm	Excess travel – at each end of the threaded length a distance l_e is subtracted to leave l_u , the useful travel. The specified lead precision does not apply to the lengths l_e . $l_u = l_1 - 2 l_e$	
F_q	N	The squeeze load applied to two nut halves (or nuts) by the housing or fixing bolts	l_m	mm	Actual mean travel. The curve is the result of measurements at 20 °C of the screw shaft. l_m is the line which fits the curve by the method of least squares.	
H_v	-	Vickers hardness	l_s	mm	Specified travel	
I	kgm^2	Inertia	l_{tp}	mm	Maximum total length	
I_L	kgm^2	Inertia of load	l_u	mm	Useful travel – the length of thread which is subject to the specified lead precision	
I_M	kgm^2	Inertia of motor	m	kg	Mass	
I_{nn}	kgm^2	Inertia of nut when turning nut	m_L	kg	Mass of the load	
I_{ns}	kgm^2	Inertia of rollers when turning shaft	m_n	kg	Mass of the nut	
I_s	kgmm^2/m	Inertia of screw shaft per metre	m_s	kg/m	Mass of the screw shaft per metre	
L	10^6 revs	Life	n	rpm	Rotational speed	
L_{10}	10^6 revs	Basic life rating, millions of revolutions	n_{cr}	rpm	Critical speed	
L_{10h}	hours	Basic life rating, operating hours	n_p	rpm	Maximum permissible speed	
M	μm	Maximum difference between mean travels of screws in a matched set	s_{ap}	mm	Maximum axial play	
N	-	Number of thread starts on the screw shaft	t	μm	Manufacturing tolerance	
N_r		Number of rollers	v	μm	Travel variation – the band width or the distance between the two straight lines parallel to the actual mean travel which enclose the curve	
P	watts	Power	v_{300}	μm	The bandwidth over any 300 mm section of the useful travel. v_{300a} and v_{300p} are actual and permissible values	
P_h	mm	Lead	v_u	μm	The bandwidth over the useful travel. v_{ua} and v_{up} are actual and permissible values	
R	$\text{N}/\mu\text{m}$	Rigidity	δ	μm	Deflection	
R_n	$\text{N}/\mu\text{m}$	Nut rigidity	\emptyset	$^\circ$	Helix angle of the screw shaft thread	
R_{ng}	$\text{N}/\mu\text{m}$	Minimum guaranteed nut rigidity	λ	$^\circ$	Friction angle	
R_{nr}	$\text{N}/\mu\text{m}$	Reference nut rigidity	μ	-	Coefficient of friction	
R_s	$\text{N}/\mu\text{m}$	Screw shaft rigidity	μ_{st}	-	Coefficient of friction when starting	
R_t	$\text{N}/\mu\text{m}$	Total rigidity	μ_F	-	Coefficient of friction for bearing	
T	Nm	Torque	σ	Mpa	Nominal axial stress	
T_B	Nm	Brake torque	σ_p	Mpa	Real axial stress	
T_{dt}	Nm	Total torque at constant speed	σ_t	Mpa	Total stress	
T_f	Nm	Torque from friction in support bearings, motor, seals, etc.	τ	Mpa	Nominal shear stress	
T_{pe}	Nm	Torque for play elimination	τ_p	Mpa	Real shear stress	
T_{pr}	Nm	Preload torque	η	-	Theoretical direct efficiency	
T_{st}	Nm	Starting torque	η'	-	Theoretical indirect efficiency	
T_t	Nm	Total torque	η_p	-	Real direct efficiency	
U	mm	Stroke length	η'_p	-	Real indirect efficiency	
V	hr^{-1}	Strokes per hour	θ	$^\circ$	Angle of twist	
W	hr/day	Hours per day	ω	rad/s^2	Angular acceleration	
X	days/year	Days per year	Ω	$\text{mm} \times \text{rpm}$	Speed quotient, $n_p \times d_o$	
Y	years	Years				
Z_s	cc	Grease quantity for screw shaft				
Z_n	cc	Grease quantity for nut				
c	μm	Travel compensation – the difference between the specified travel and the nominal travel. Its value is always defined by the customer: if not specified it will be assumed to be zero. (The specified travel can also be defined by the specified lead multiplied by the number of revolutions).				



The right solution under all conditions.

According to its own survival mode or defence demands, the chameleon can quickly change its own skin colour in order to reduce its visibility to any predator. This ability of a species to adapt to the surrounding environment has served as an inspiration for SKF to create customised solutions which are totally in line with individual requirements.

Beyond the standard product range SKF designs and manufactures the ideal solutions to render each application faster and more efficient.

Ask SKF. Your customised solution is close at hand.

Linear motion from SKF
www.linearmotion.skf.com



Actuation systems

About actuation systems

Linear drive applications often require superior performance from the actuator. They must exhibit this in terms of speed, temperature stability, accuracy and noise levels. SKF produces a complete range of actuator products designed to satisfy the most demanding requirements.

In addition to SKF the incorporation of the Magnetic® brand results in excellence in competence and the overall product assortment, which includes telescopic pillars (→ figure 1), linear (→ figure 2) and rotary actuators (→ figure 3) as well as control units (→ figure 4), providing a total system solution for various applications. SKF holds a leading position in the industrial field where actuators are used in many different applications. SKF supplies a wide range of actuators but also offers extensive knowledge and experience in application engineering. This background has developed through long-standing partnership with leading companies in many industrial sectors.

Operating precision (→ Table 1)

Comparison of the different positioning components and systems.

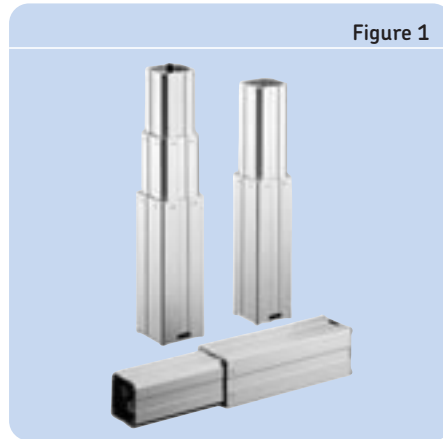

Figure 1

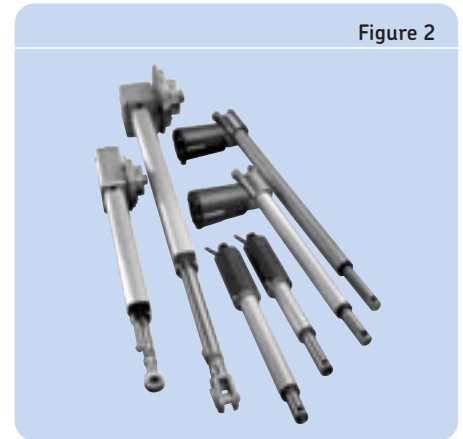

Figure 2

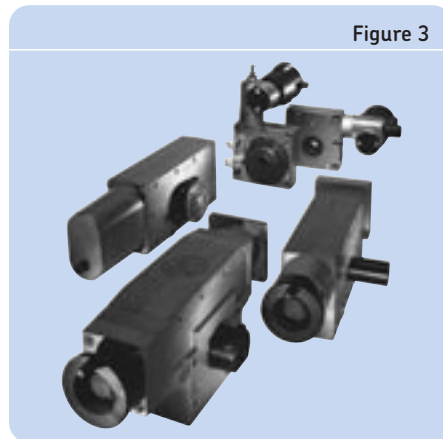

Figure 3

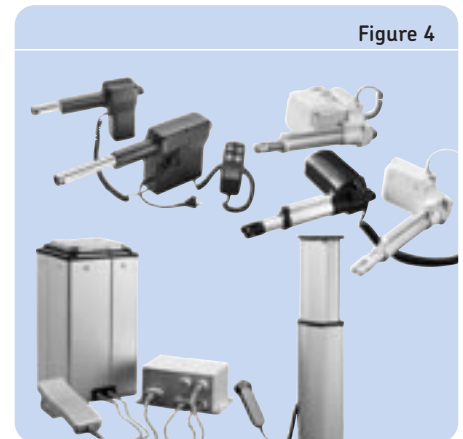

Figure 4

© SKF and Magnetic are registered trademarks of the SKF Group

Operating precision (µm)	Guiding systems	Driving systems	Actuation systems	Positioning systems
0.1 - 1	Precision rail guides	Roller screws		
1 - 10	Profile rail guides	Ball screws		
10 - 100	Linear ball bearings			
100 - 1000	Standard slides	Linear motors	Electro-mechanical actuators	Standard drives or linear motors with all guiding systems
	Cam roller guides			

Selection guide

Selecting actuators, made easy

Finding the right electric actuator for an application usually requires knowing many application details and making several calculations.

However, there are ways to narrow the selection to one or two safe approximations first. Using the selection guide, on following **pages 157-164** you may easily find those actuators that meet your first criterias of load and speed as well as basic information about available controls and operating devices. This is normally the most important first step to carry out. On the **pages 167-293** you will find detailed information and type keys of each individual product(s). In case you need more explanation on technical terminology (glossary) and important considerations in selecting the right actuator for your applications, **pages 302-304** may be useful.

NB:

In addition to this catalogue we have all product brochures available as pdf document on the internet.

www.linearmotion.skf.com/doc

Linear actuators

Diagram 1

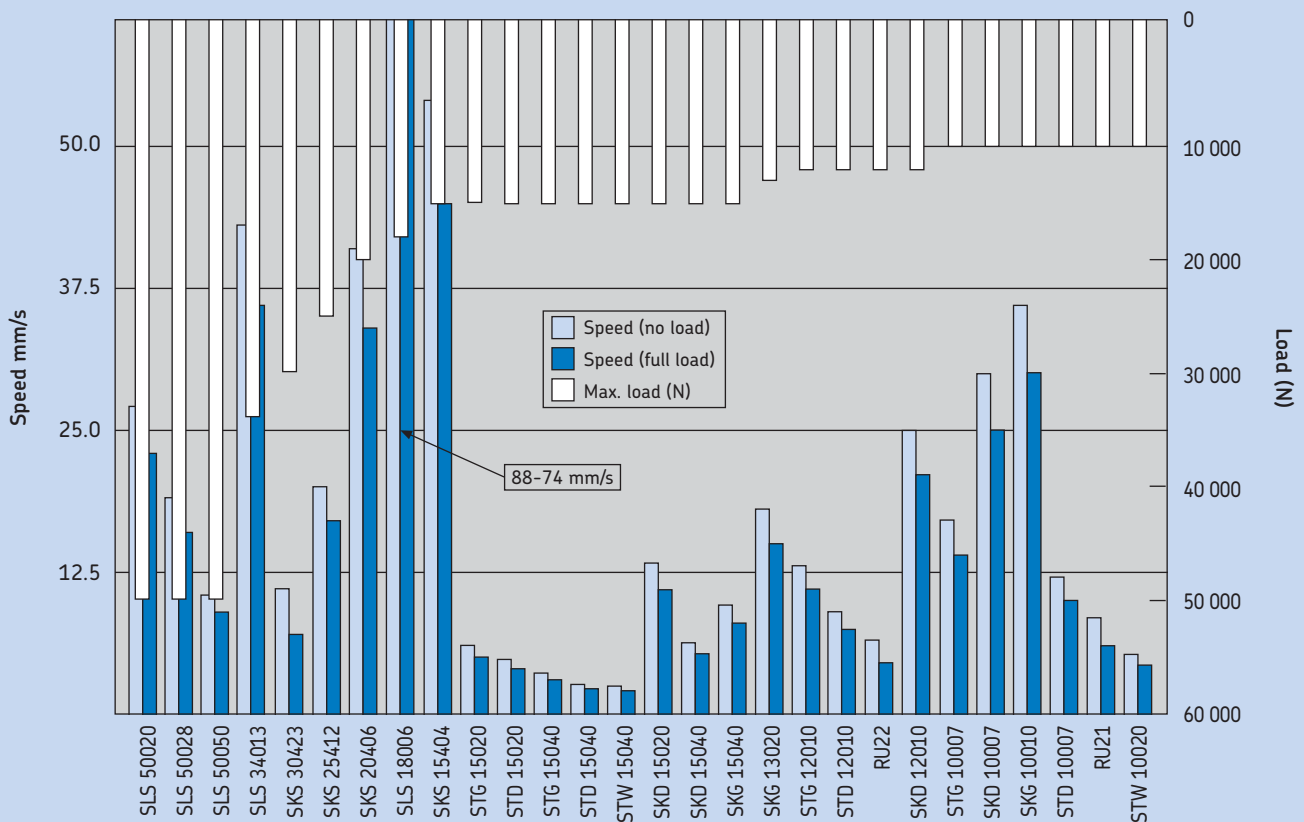

Diagram 2

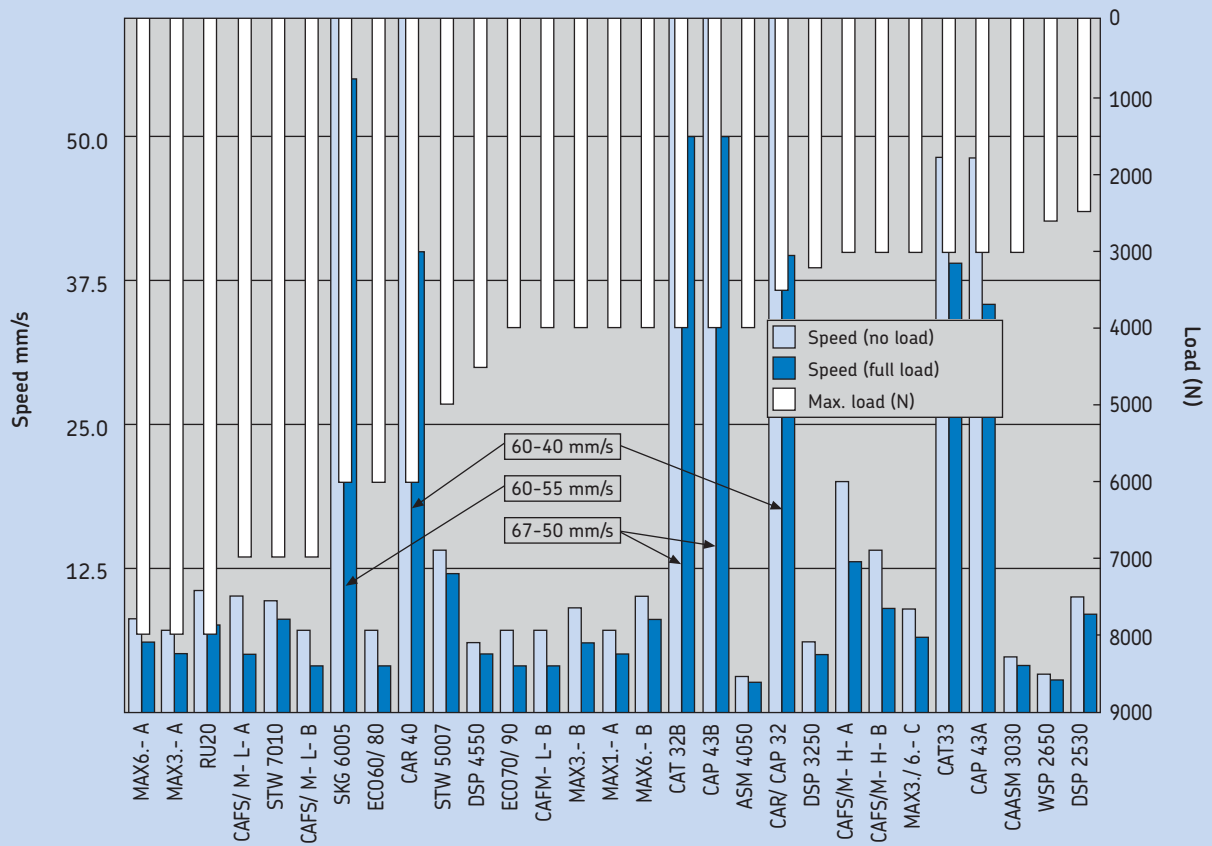
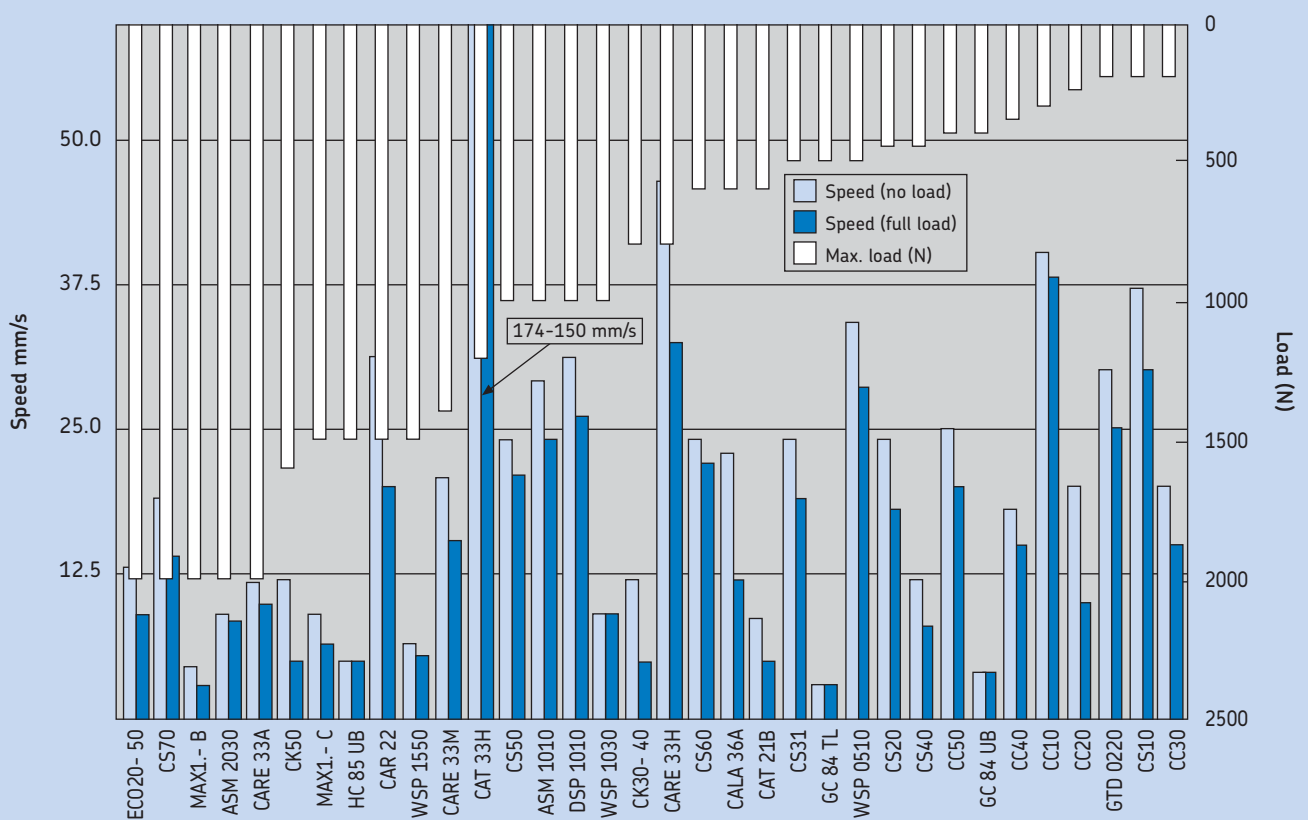

Diagram 3



Telescopic pillars

Diagram 4

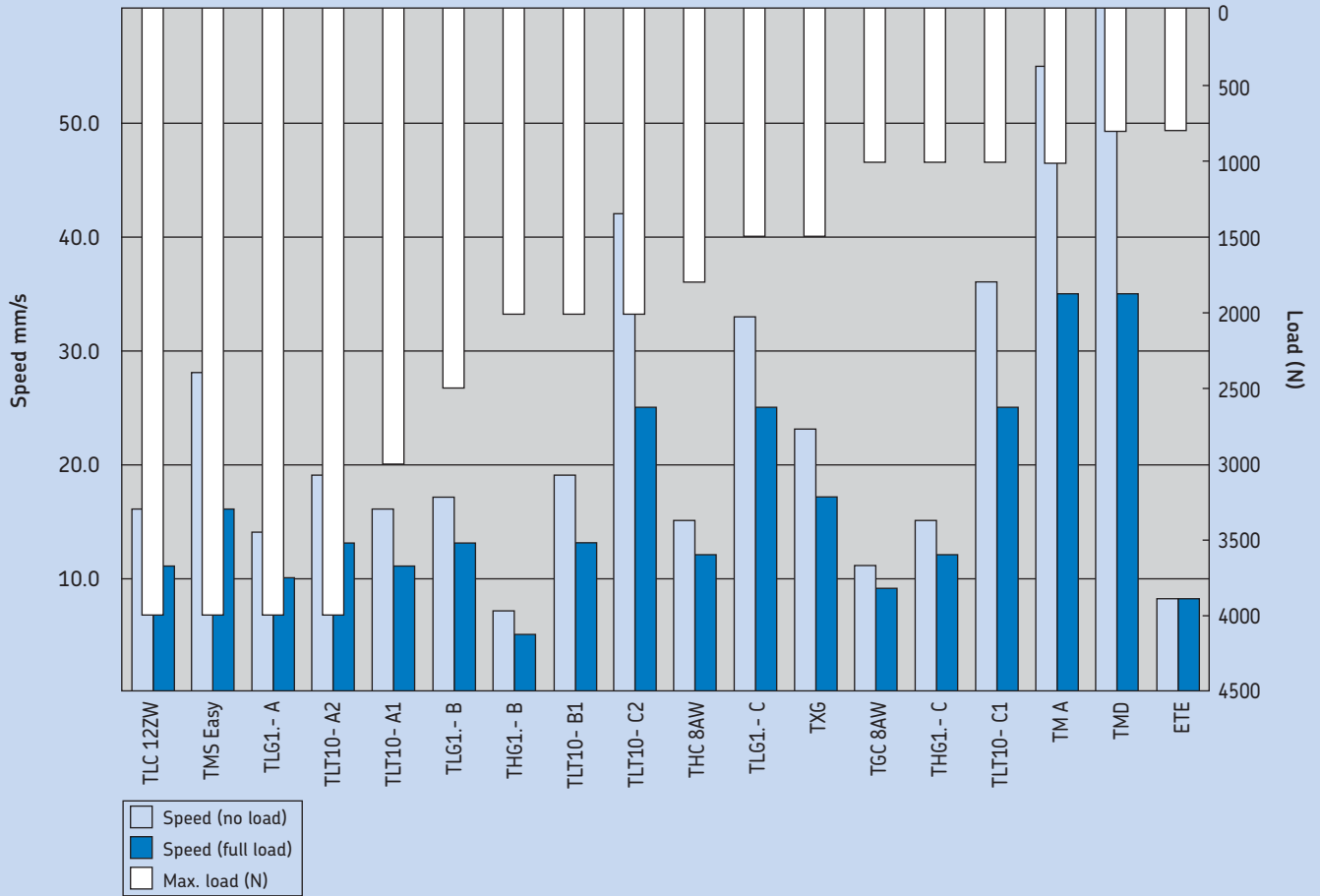

Table 2





Telescopic pillars	Type	Max. force		Max. Speed		Stroke (S)	Features	Page
		push	pull	no load	full load			
		N		mm/s		mm		No.
TELEMAG								
	TGC	1000	1000	11	9	200 - 700	Robust	168
	THC	1800	1800	15	12	200 - 700	Robust	169
	THG	2000	0	15	12	200 - 700	Robust	170
	TLC	4000	4000	16	11	100 - 700	Robust	171
	TLG	4000	0	33	25	200 - 700	Robust	172
	TLT	4000	0	42	25	300 - 700	Compact	173
TMS								
	EASY	4000	0	28	16	250 - 700	For excentric loads	174
	MECH	4000	0	-	-	250 - 700	For excentric loads	174
TELESMART								
	TMD	800	0	60	35	700	Slim & stylish	177
	TMA	1000	0	55	35	500	Slim & stylish	178
	TXG	1500	0	23	17	200 - 600	Plug & play	179
MAGGEAR								
	ETE	800	200	8	8	200	In-line	180

Table 3

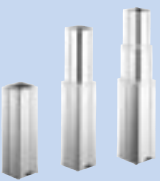
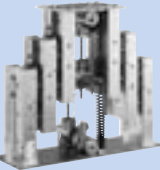

Linear actuator	Type	Max. force		Max. Speed		Stroke (S)	Features	Page
		push	pull	no load	full load			
		N		mm/s		mm		No.
CAT								
	CAT 21B	600	600	10	5	50 - 300	Compact	183
	CAT 33H	1200	1200	174	150	100 - 400	Flexible, modular	184
	CAT 33	3000	3000	48	38	100 - 400	Flexible, modular	186
	CAT 32B	4000	4000	67	50	50 - 700	Flexible, modular	188
CAP								
	CAP 32	3500	3500	60	40	50 - 700	High duty factor	193
	CAP 43A	3000	3000	48	35	100 - 400	Positioning	194
	CAP 43B	4000	4000	65	50	50 - 700	Positioning	195

Continued

4 Actuation systems





Selection guide

Table 3 (continued)

Linear actuator	Type	Max. force		Max. Speed		Stroke (S)	Features	Page
		push	pull	no load	full load			
		N		mm/s		mm	No.	
	CAR 22	1500	1500	30	20	50 - 300	High duty factor	198
	CAR 32	3500	3500	60	40	50 - 700	High duty factor	199
	CAR 40	6000	6000	60	40	100 - 700	High duty factor	200
	CARN 32	3500	3500	N/A	N/A	50 - 700	No motor	201
	CCBR 32	2500	2500	N/A	N/A	50 - 700	No motor	202
	GTD	200	200	30	25	50 - 300	Powerful	204
	WSP	2600	2600	68	57	100 - 700	Powerful	205
	ASM	4000	4000	58	48	100 - 700	Powerful	206
	DSP	4500	4500	62	52	100 - 700	Powerful	207
	SKG	15000	15000	66	55	100 - 700	Powerful	208
	SKD	15000	15000	30	25	100 - 700	Powerful	209
	STW	15000	15000	14	12	100 - 700	Powerful	210
	STG	15000	15000	17	14	100 - 700	Powerful	211
	STD	15000	15000	12	10	100 - 700	Powerful	212
	SKS	30000	30000	54	45	100 - 700	Powerful	213
SLS	50000	50000	88	74	100 - 700	Powerful	214	
	ECO	6000	2000	13	9	50 - 300	Compact	216
	CALA 36A	600	600	23	12	50 - 200	In-line	219
	MAX1	4000	4000	18	13	50 - 700	Silent operation	221
	MAX3	8000	6000	18	13	50 - 700	Silent operation	222
	MAX6	8000	6000	18	13	50 - 700	Plug & play	223
	CARE 33H	800	800	45	32	50 - 500	Silent operation	224
	CARE 33M	1400	1400	22	16	50 - 500	Silent operation	224
	CARE 33A	2000	2000	12	8	50 - 300	Silent operation	224
	RU	12000	8000	10	7	100 - 700	High push force	227

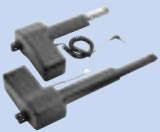
Continued

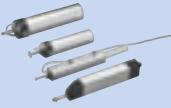
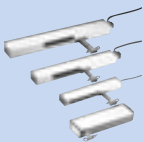
Table 3 (continued)

Linear actuator	Type	Max. force		Max. Speed		Stroke (S)	Features	Page
		push	pull	no load	full load			
		N		mm/s		mm		No.
CAFM 	CAFM	7000	3000	20	13	50 - 300	High speed, silent, powerful	228
CAFS 	CAFS	7000	3000	20	13	50 - 300	High speed, silent, powerful	230
MAGPUSH 	GC 84 UB LC 6.6 UB LC 12.6 UB GC 84 TL HC 85 UB	400 3000 6000 500 1500	400 3000 6000 300 1500	8 15 30 6 10	8 15 30 6 10	210 310 310 200 - 500 260	Silent operation Silent operation Silent operation Silent operation Silent operation	233 233 233 234 235
MAGTOP 	CS10 CS20 CS31 CS40 CS50 CS60 CS70	200 450 500 450 1000 600 2000	200 450 500 450 1000 600 2000	37 22 24 12 24 24 19	30 18 19 8 21 22 14	105 - 300 160 - 300 200 - 400 200 - 500 300 - 500 180 - 500 180 - 500	Small & compact Small & compact Small & compact Small & compact Small & compact Small & compact Small & compact	237 238 239 240 241 242 243
VARIMAG 	CC10 CC20 CC30 CC40 CC50	150 200 250 350 400	300 200 250 350 400	45 17 32/28 19 28/38	38 10 28/26 15 17/22	130 - 380 200 - 250 400 280 - 380 420 - 835	Small & compact Small & compact Small & compact Small & compact Small & compact	245 246 247 248 249
MAGRACK 	CK	1600/1200	1600/1200	12/7	10/5	180 - 1000	Small & compact	250

4 Actuation systems

Selection guide

Table 4



Rotary actuators	Type	Max. Torque	Max. Speed	Size	Features	Page
		Nm	rpm	mm		No.
CRAB 17 	CRAB 17	70	8	125	Compact	254
	CRAB 17	105	20	125	Compact	254
CRAB 05 	CRAB 05	100	3	86	Compact	257

Table 5

Control units	Type	Control	Max. motor connections	Input	Output	Page
			n°	V	V/A	No.
KOM 	KOM 1	Basic functions	4	230/120	24/6	259
	KOM 2	Encoder processing	5	230/120	24/6 or 12	260
	KOM 3	Basic functions	3	230/120	24/6	261
	KOM 3T	Basic functions	2	230/120	24/9	261
	KOM 6	Encoder processing	4	230/120	24/6 or 12	262
MCU 	MCU	Basic functions	2	24	24/6	263
LD 	LD-015	Encoder processing	2	230/120	24/10	264
	LD-014	Encoder processing	4	230/120	24/12	
SEM 	SEM1	Basic functions	4	230/120	24/5	265
CAFC 04 	M1	Encoder processing	1	230/120	40/6	266
	M2	Encoder processing	2	230/120	40/6	266
	M3	Encoder processing	3	230/120	40/6	266

Continued

Table 5 (continued)

Control units	Type	Control	Max. motor connections	Input	Output	Page
			n°	V	V/A	No.
	M1	Encoder processing	1	230/120	40/6	267
	M2	Encoder processing	2	230/120	40/6	267
	M3	Encoder processing	3	230/120	40/6	267
	15	Basic functions	1	230	24/15	267
	10R	Basic functions	1	230/120	24/1-10	268
	110/220	Basic functions	1	230/120	400/200	268
	5-24R - P O	Encoder processing	1	22-28	24/5	268
	9-24R - P O	Encoder processing	1	22-28	24/9	268
	3-24R	Basic functions	1	24	24/3	269
	5-24R	Basic functions	1	24	24/5	269
	9-24R	Basic functions	1	24	24/9	269
	10P-SL	Basic functions	1	230	24/2-10	269
	8V	Basic functions*	1	230	24/10	269
* Dimension of housing: 260×260×107 mm						
	10-24R	Basic functions	1	24DC/19AC	24/2-10	269
	BCU	Basic functions	3	230/120	24/7	270

4 Actuation systems

Selection guide

Table 6

Hand switch	Type	Operating power	Max. operating motors	Prot. class	Colour	Page
		VDC/mA	n°	IP		No.
EHA 	EHA 1	12/50	4	67	Grey	272
	EHA 2	12/50	5	67	Grey	273
	EHA 3	12/50	4	67	Grey	274
IHA 	IHA 1	-	5	67	Black	275
EHE 	EHE 1/3	38/50	4	X7	Grey/black	276
	EHE 6	38/50	5	X7	Grey	277
PHC 	PHC	-	4	66	Anthracite	278
CAFH 	M1	40/50	1	X4	Grey/black	278
	M2	40/50	2	X4	Grey/black	278
	M3	40/50	3	X4	Grey/black	278
CAES 	CAES 31B	30/33	1	54	Black	278
	CAES 31C	30/33	1	54	Black	278
	CAES 31D	30/33	1	54	Black	278
	CAES 32D	30/33	2	54	Black	278

Table 7



Foot switches	Type	Operating Power	Max. operating motors	Prot. class	Colour	Page
		VDC/mA	n°	IP		No.
	ST	12/50	3	X5	Blue/anthracite	280
	PFP1	-	1	21	Grey or anthracite	281
	PFP2	-	2	21	Grey or anthracite	281
	F1-DIN5	40/50	1	X4	Anthracite	281
	F1-DIN7	40/50	1	X4	Anthracite	281

Table 8

Desk switch	Type	Operating Power	Max. operating motors	Prot. class	Colour	Page
		VDC/mA	n°	IP		No.
	ST	12/50	3	X0	Black	283
	LD	5/50	2	32	Black	284
	T1	40/50	1	X4	Grey or black	285
	T2	40/50	2	X4	Grey or black	285

4 Actuation systems

Selection guide/Combination matrix for actuators & controls

Table 9

Desk switch (pneumatic)	Type	Max. operating motors		Tube	Colour	Page
		n°				No.
	PAM 1-130827	1		None	Light grey	285
	PAM 1-130659	1		2.65 m coiled	Light grey	285
	PAM 1-130256	1		1.50 m straight	Anthracite	285
	PAM 1-130966	1		3.00 m straight	Anthracite	285
	PAM 1-130348	1		2.65 m coiled	Anthracite	285

Table 10

Junction box	Type	Operating Power	Max. operating motors	Prot. class	Colour	Page
		VDC / mA	n°			IP
	DIN5	40/50	2	X4	Grey	286
	DIN7	40/50	2	X4	Grey	286

Table 11



Easy3	Type	Max. force		Speed		Stroke (S)	Features	Page
		push	pull	no load	full load			No.
		N		mm/s		mm		No.
	02	600	600	23	12	50 - 200	In-line	288
	03	2000	2000	12	8	100 - 300	Silent operation	288
	04	2000	2000	12	8	100 - 300	Silent operation	289
	05	2000	2000	12	8	100 - 300	Silent operation	289
	10	7000	3000	7	4	100 - 200	Powerful & silent	290
	11	7000	3000	7	4	100 - 200	Powerful & silent	290
	12	7000	3000	7	4	100 - 200	Powerful & silent	291
	13	7000	3000	7	4	100 - 200	Powerful & silent	291

Table 12

Guiding tubes	Type	Section		Stroke (S)	Page
		2	3		No.
	FRE	x	x	200 - 700	293

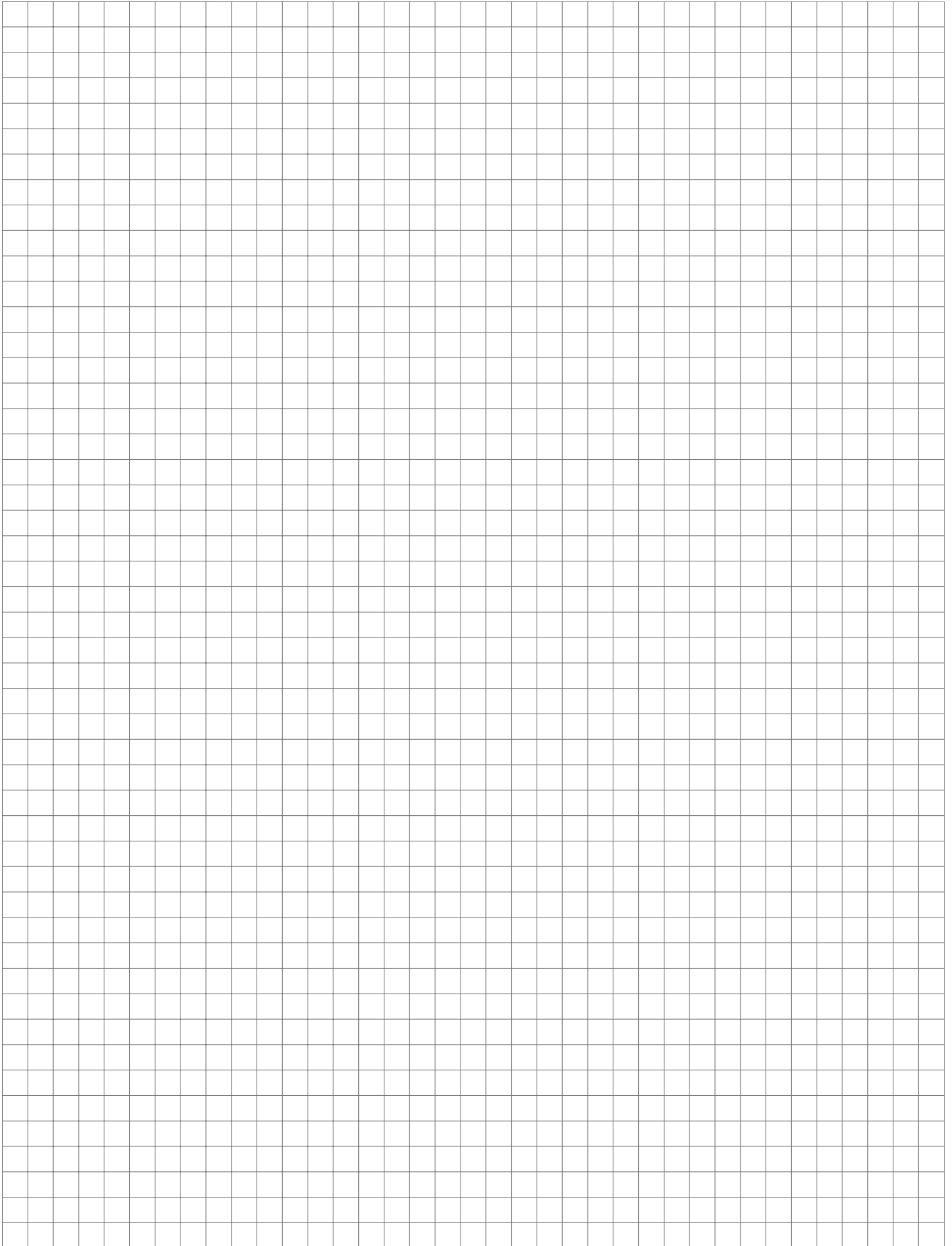

Telescopic pillars

TELEMAG

The TELEMAG line of telescopic pillars features the best combination of minimum retracted length and large stroke length (→ figure 5). They are used wherever robust and safe guiding systems are needed. The attractive design allows the TELEMAG to often become part of the overall design of the equipment. The line of TELEMAG actuators is complemented by the KOM control units, which allow a flexible and application focused system control.

Benefits:

- High offset load
- Silent operation
- Robust
- Long life time

Figure 5



Type	Force		Max. Speed		Stroke (S)	Retr. Length (L)	Voltage	Protection	Weight
	push	pull	no load	full load					
	N		mm/s		mm	mm	V	IP	kg
TGC 8AWA	1000	1000	11	9	200 - 700	S + 145/150	120/230 AC	30	4.5 - 7.5
TGC 8AWD	1000	1000	11	9	300 - 700	S + 45/50	120/230 AC	30	5.9 - 9.5
THC 8AWA	1800	1800	15	12	200 - 700	S + 155/160	120/230 AC	30	7.9 - 13.5
THC 8AWD	1800	1800	15	12	230 - 700	S + 60/65	120/230 AC	30	8.6 - 17.5
TLC 12ZWA	4000	4000	16	11	100 - 700	S + 175/185	120/230 AC	30	15.2 - 24.5
TLC 12ZWD	4000	4000	16	11	255 - 700	S + 60/70	120/230 AC	30	18.3 - 30.5
THG 10/11-C	1000	0	15	12	200 - 700	S + 270/180	24 DC	30	8 - 14
TLT 10-C1	1000	0	36	25	300 - 700	S × 0.5 + 170	24 DC	40	15 - 30
TLG 10/11-C	1500	0	33	25	200 - 700	S + 180	24 DC	30	15 - 30
THG 10/11-B	2000	0	7	5	200 - 700	S + 270/180	24 DC	30	8 - 14
TLT 10-B1	2000	0	19	13	300 - 700	S × 0.5 + 170	24 DC	40	15 - 30
TLT 10/11-C2	2000	0	42	25	300 - 700	S × 0.5 + 240	24 DC	40	15 - 30
TLG 10/11-B	2500	0	17	13	200 - 700	S + 180	24 DC	30	15 - 30
TLT 10-A1	3000	0	16	11	300 - 700	S × 0.5 + 170	24 DC	40	15 - 30
TLG 10/11-A	4000	0	14	10	200 - 700	S + 180	24 DC	30	15 - 30
TLT 10/11-A2	4000	0	19	13	300 - 700	S × 0.5 + 240	24 DC	40	15 - 30

TELEMAG THC

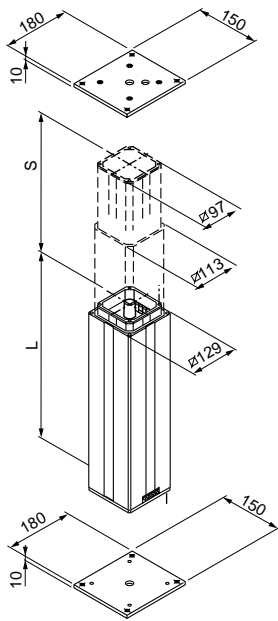

Legend:
S = stroke
L = retracted length

Type	Force		Max. speed		Stroke (S)	Retr. Length (L)	Voltage	Protection	Weight
	push	pull	no load	full load					
	N		mm/s		mm	mm	V AC	IP	kg
THC 8AWA	1800	0	15	12	200 - 700	S+155	120/230	30	7.9 - 13.5
THC 8AWA	0	1800	15	12	200 - 700	S+160	120/230	30	7.9 - 13.5
THC 8AWD	1800	0	15	12	230 - 700	S+60	120/230	30	8.6 - 17.5
THC 8AWD	0	1800	15	12	230 - 700	S+65	120/230	30	8.6 - 17.5

Type code for accessories

Accessories	Order N°
Top mounting plate for 2× tube set	264265
Bottom mounting plate for 2× tube set	264363
Top mounting plate for 3× tube set	264265
Bottom mounting plate for 3× tube set	264237
Screw (4/plate) for top mounting plate	510671
Screw (4/plate) for bottom mounting plate	510709
Plug AC Telemag 3p.	265518
Plug AC Telemag 5p.	265519

Ordering key

Type	THC	8	A	W														
Load/Speed: 1800 N/15 - 12 mm/s.....																		A
Tube set: Tube set 2×																		A
Tube set 3×																		D
Control: Electrical control																		S
Pneumatic control																		K
Motor voltage: 230 V AC/50 Hz																		(no code)
120 V AC/60 Hz																		2
System of protection: Standard IP 30																		(no code)
UL approval																		U
Construction: Push																		0
Colour: Aluminium anodised																		0
Stroke (S): 100 mm																		1
200 mm (only for tube set 2×)																		2
300 mm																		3
400 mm																		4
500 mm																		5
600 mm																		6
700 mm																		7

Example: **THC 8 A W D S 2 - 0 0 4**

4 Actuation systems

Telescopic pillars

TELEMAG THG

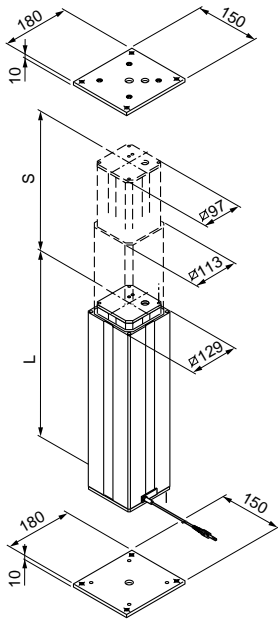

Legend:
S = stroke
L = retracted length

Type	Force		Max. speed		Stroke (S)	Retr. Length (L)	Voltage	Protection	Weight
	push	pull	no load	full load					
THG 10/11-BA	2000	0	7	5	200 - 700	S + 270	24	30	8 - 14
THG 10/11-BD	2000	0	7	5	200 - 700	S + 180	24	30	8 - 14

Type code for accessories

Accessories	Order N°
Top mounting plate for 2 × tube set	264265
Bottom mounting plate for 2 × tube set	264363
Top mounting plate for 3 × tube set	264265
Bottom mounting plate for 3 × tube set	264237
Screw (4/plate) for mounting plate (2 tube set)	510709
Screw (4/plate) for mounting plate (3 tube set)	510707

Ordering key

	THG1	0	B						000
Type									
Motor voltage: 24 V DC	0								
Load/Speed: 2000 N / 7 - 5 mm/s	B								
Tube set: Tube set 2 ×	A								
Tube set 3 ×	D								
Stroke (S): 200 mm	2								
300 mm	3								
400 mm	4								
500 mm	5								
600 mm	6								
700 mm	7								
Cable/connecting plug: Straight, 2.3 m, jack plug	2								
Straight, 1.0 m, DIN8 plug	3								
Straight, 2.3 m, DIN8 plug	4								
Coiled, 0.6 m, DIN8 plug	B								
Option: No option	(no code)								
Encoder, 8 pulses/revolution	0								
Potentiometer, 1 kΩ, 2 Watt, 0.25% linearity, 10 turns (tube set 3 × only)	A								

Example: **THG1** **0** - **B A 3 2 A** - **000**

TELEMAG TLC

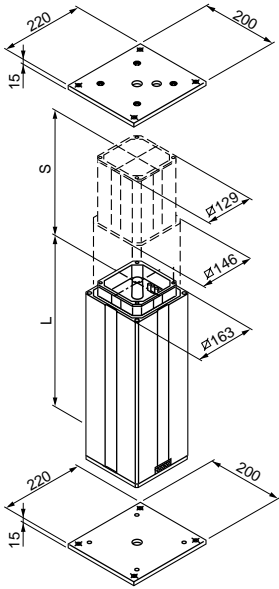

Legend:
S = stroke
L = retracted length

Type	Force		Max. speed		Stroke (S)	Retr. Length (L)	Voltage	Protection	Weight
	push	pull	no load	full load					
	N		mm/s		mm	mm	V AC	IP	kg
TLC 12ZWA	4000	0	16	11	100 - 700	S+175	120/230	30	15.2 - 24.5
TLC 12ZWA	0	4000	16	11	200 - 700	S+185	120/230	30	15.2 - 24.5
TLC 12ZWD	4000	0	16	11	255 - 700	S+60	120/230	30	18.3 - 30.5
TLC 12ZWD	0	4000	16	11	300 - 700	S+70	120/230	30	18.3 - 30.5

Type code for accessories

Accessories	Order N°
Top mounting plate for 2× tube set	290268
Bottom mounting plate for 2× tube set	290351
Top mounting plate for 3× tube set	290268
Bottom mounting plate for 3× tube set	290265
Screw (4/plate) for mounting plate	510707
Plug AC Telemag 3p.	265518
Plug AC Telemag 5p.	265519

Ordering key

TLC
12
Z
W

-
0

Type

Load/Speed:
4000 N/16 - 11 mm/s. Z

Tube set:
Tube set 2× A
Tube set 3× D

Control:
Electrical control S
Pneumatic control K

Motor voltage:
230 V AC/50 Hz (no code)
120 V AC/60 Hz 2

System of protection:
Standard IP 30 (no code)
UL approval U

Construction:
Push 0

Colour:
Aluminium anodised 0

Stroke (S):
100 mm, only for tube set 2×, push 1
255 mm, only for tube set 3×, push 1
200 mm, only for tube set 2× 2
300 mm 3
400 mm 4
500 mm 5
600 mm 6
700 mm 7

Example: TLC 12 Z W D K - 0 0 7

4 Actuation systems
Telescopic pillars

TELEMAG TLG

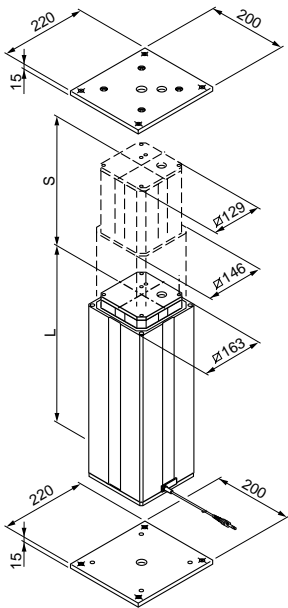

Legend:
S = stroke
L = retracted length

Type	Force		Max. speed		Stroke (S)	Retr. Length (L)	Voltage	Protection	Weight
	push	pull	no load	full load					
	N		mm/s		mm	mm	V DC	IP	kg
TLG 10/11-A	4000	0	14	10	200 - 700	S + 180	24	30	15 - 30
TLG 10/11-B	2500	0	17	13	200 - 700	S + 180	24	30	15 - 30
TLG 10/11-C	1500	0	33	25	200 - 700	S + 180	24	30	15 - 30

Type code for accessories

Accessories	Order N°
Top mounting plate for 2× tube set	290268
Bottom mounting plate for 2× tube set	290351
Top mounting plate for 3× tube set	290268
Bottom mounting plate for 3× tube set	290265
Screw (4/plate) for mounting plate	510707

Ordering key



Type

Motor voltage:

24 V DC 0

Load/Speed:

4000 N / 14 - 10 mm/s A
 2500 N / 17 - 13 mm/s B
 1500 N / 34 - 25 mm/s C

Tube set:

Tube set 2× A
 Tube set 3× D

Stroke (S):

200 mm 2
 300 mm 3
 400 mm 4
 500 mm 5
 600 mm 6
 700 mm 7

Cable/connecting plug:

Straight, 2.3 m, jack plug 2
 Straight, 1.0 m, DIN8 plug 3
 Straight, 2.3 m, DIN8 plug 4
 Coiled, 0.6 m, DIN8 plug B

Option:

No option 0
 Encoder, 8 pulses/revolution A
 Potentiometer, 1 kΩ, 2 Watt, 0.25% linearity, 10 turns B

Example: **TLG1** **0** - **C A 6 2 A** - **000**

TELEMAG TLT

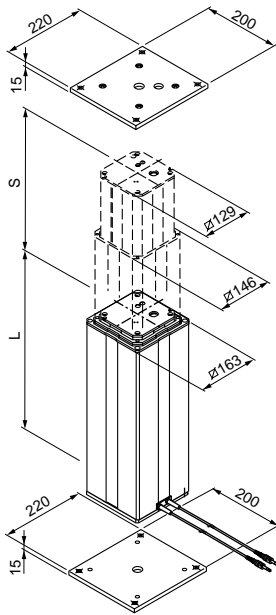

Legend:
S = stroke
L = retracted length

Type	Force		Max. speed		Stroke (S)	Retr. Length (L)	Voltage	Protection	Weight
	push	pull	no load	full load					
	N		mm/s		mm	mm	V DC	IP	kg
TLT10-A1	3000	0	16	11	300 - 700	0.5 × S + 170	24	40	15 - 30
TLT10/11-A2	4000	0	19	13	300 - 700	0.5 × S + 240	24	40	15 - 30
TLT10-B1	2000	0	19	13	300 - 700	0.5 × S + 170	24	40	15 - 30
TLT10-C1	1000	0	36	25	300 - 700	0.5 × S + 170	24	40	15 - 30
TLT10/11-C2	2000	0	42	25	300 - 700	0.5 × S + 240	24	40	15 - 30

Type code for accessories

Accessories	Order N°
Top mounting plate	290268
Bottom mounting	290265
Screw (4/plate) for mounting plate	510707

Ordering key

Type	TLT1	0	-				-	000
Motor voltage:	24 V DC	0						
Load/Speed:	4000 N / 19 - 13 mm/s							A2
	3000 N / 16 - 11 mm/s							A1
	2000 N / 19 - 13 mm/s							B1
	2000 N / 45 - 25 mm/s							C2
	1000 N / 36 - 25 mm/s							C1
Stroke (S):	300 mm							3
	400 mm							4
	500 mm							5
	600 mm							6
	700 mm							7
Cable/connecting plug:	Straight, 1.0 m, DIN8 plug							3
	Straight, 2.3 m, DIN8 plug							4
	Coiled, 0.6 m, DIN8 plug							B
Option:	No option							0
	Encoder, 8 pulses/revolution, only with jack plug							A

Example: TLT1 0 - B1 5 1 A - 000

4 Actuation systems

Telescopic pillars

TMS

The TMS is a strong telescopic pillar (→ **figure 6**) with an optimal stroke/retracted length ratio for the lift of heavy excentric loads.

The TMS is fast, silent and able to lift 400 kg centric load or 150 kg eccentric load in a 2 m distance away from the pillar.

Benefits:

- High offset load
- Fast
- Strong

Figure 6

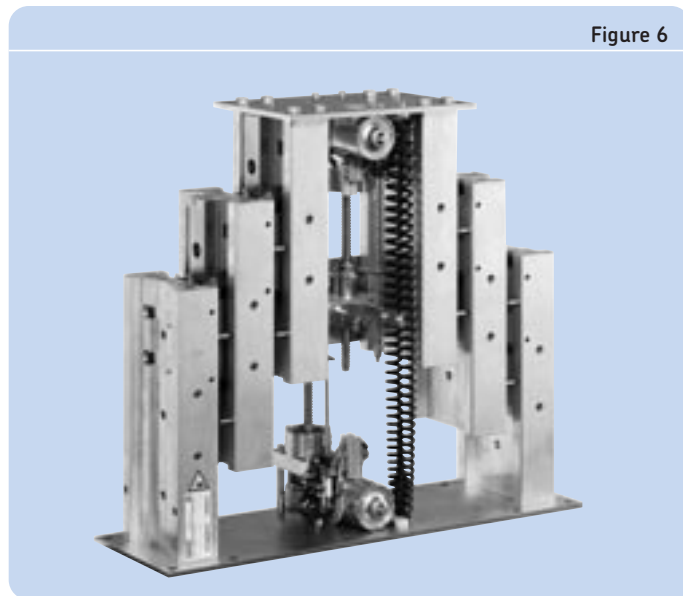

Type	Force		Max. speed		Stroke (S)	Retr. Length (L)	Voltage	Protection	Weight
	push	pull	no load	full load					
	N		mm/s		mm	mm	V	IP	kg
EASY	4000	-	28	16	250 - 700	S×0.5+176	24	SELV	64 - 85
MECHANICAL	4000	-	-	-	250 - 700	S×0.5+176	-	-	61 - 82

TMS EASY/MECHANICAL

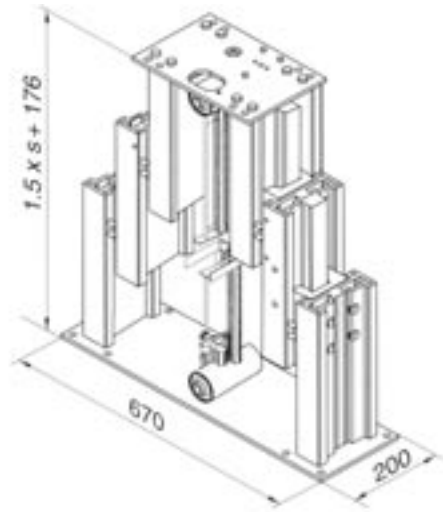
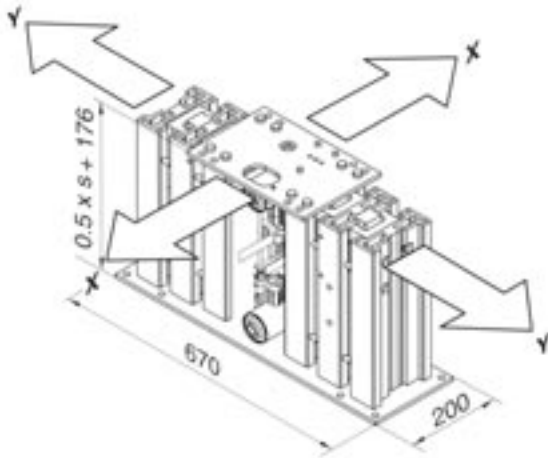

Ordering key

Type

Voltage:

- No (mechanical) 0
- 24 V DC (easy) 1

Number of channels:

- Not used 0

Connecting cable:

- Not used (mechanical) 00
- Coiled, 1.5 m, jack plug (easy) WR

Colour/Design:

- Not used 0

Options:

- None 000

Stroke (S):

- 300 mm 300
- 400 mm 400
- 500 mm 500
- 600 mm 600
- 700 mm 700

TMS 0 - 0 000 - 00

Example: TMS 1 0 - ZR 0 000 - 600 00

4 Actuation systems

Telescopic pillars

TELESMART

This cost effective telescopic pillar offers an attractive design for height adjustable desks, tables, chairs and lightweight industrial workstations (→ **figure 7**).

The TXG series has an integrated control unit and combines the advantages of AC and DC power. The TMA & TMD series are very stylish and ideal for office environment.

The pillars can be controlled by using desk, hand or foot switches.

Benefits:

- Easy plug and play system
- Powerful and fast lifting
- Attractive design
- Cost effective

Figure 7



Type	Force		Max. speed		Stroke (S)	Retr. Length (L)	Voltage	Protection	Weight
	push	pull	no load	full load					
	N		mm/s		mm	mm	V	IP	kg
TMD	800	0	60	35	700	550	24 DC	20	8.5
TMA	1000	0	55	35	500	640	24 DC	20	8
TXG 1	1500	0	23	17	200 - 600	S + 160/180	24 DC	30	8 - 13
TXG 4/5	1500	0	23	17	200 - 600	S + 160/180	120 AC	30	9 - 14
TXG 8/9	1500	0	23	17	200 - 600	S + 160/180	230 AC	30	9 - 14

TELESMART TMD

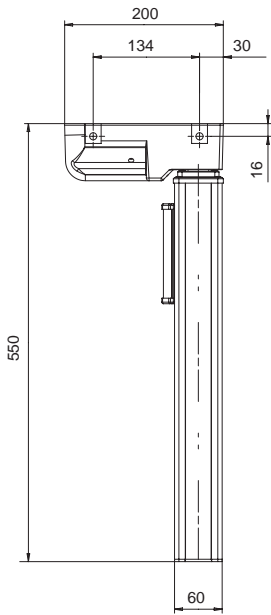

Type	Force		Max. speed		Stroke (S)	Retr. Length (L)	Voltage	Protection	Weight
	push	pull	no load	full load					
TMD	800	0	60	35	700	550	24	IP20	8.5

Type code for accessories

Accessories	Order N°
Cable 1.0 m with DIN8-plug	306355-1000
Cable 1.5 m with DIN8-plug	306355-1500
Cable 2.5 m with DIN8-plug	306355-2500

Ordering key

	TMD	1	0	-	00		-	700	00
Type									
Voltage: 24 V DC			1						
Number of channels: Not used			0						
Connecting cable: None				00					
Colour/Design: Natural anodized coating					5				
Black anodized coating					6				
Options: With flange for crossbar one side								EWY	
With flange for crossbar two sides								2CM	
No flange for crossbar								2CN	
Stroke / Retracted length: Stroke (S) = 700 mm, Retracted length (L) = 550 mm								700	

Example: TMD 10 - 0052CM - 70000

4 Actuation systems
Telescopic pillars

TELESMART TMA

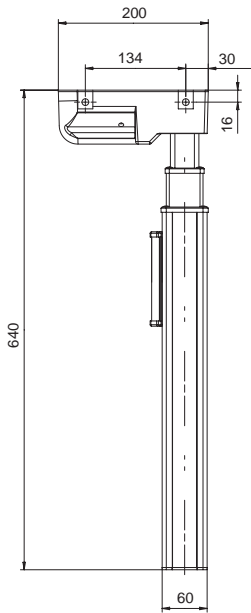

Type	Force push pull	Max. speed no full load load	Stroke (S)	Retr. Length (L)	Voltage	Protection	Weight
TMA	N 1000 0	55 35	500	640	24	IP 20	8 kg

Type code for accessories

Accessories	Order N°
Cable 1.0 m with DIN8-plug	306355-1000
Cable 1.5 m with DIN8-plug	306355-1500
Cable 2.5 m with DIN8-plug	306355-2500

Ordering key

Type	TMA	1	0	-	00		-	500	00
Voltage: 24 V DC			1						
Number of channels: Not used			0						
Connecting cable: None					00				
Colour/Design: Natural anodized coating						5			
Black anodized coating						6			
Options: With flange for crossbar one side								EWY	
With flange for crossbar two sides								2CM	
No flange for crossbar								2CN	
Stroke/Retracted length: Stroke (S) = 500 mm, Retracted length (L) = 640 mm									500

Example: TMA 1 0 - 00 5 2CM - 500 00

TELESMART TXG

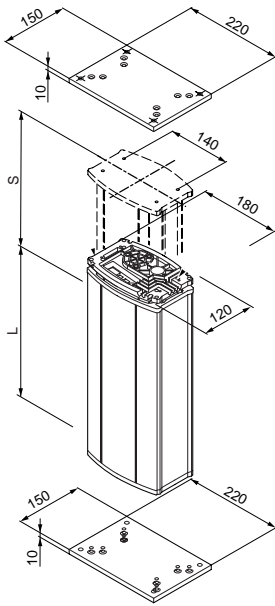

Legend:
S = stroke
L = retracted length

Type	Force		Max. speed		Stroke (S)	Retr. Length (L)	Voltage	Protection	Weight
	push	pull	no load	full load					
	N		mm/s		mm	mm	V	IP	kg
TXG 1	1500	0	23	17	200 - 600	S+180/160		24 DC	30 8 - 13
TXG 4/5	1500	0	23	17	200 - 600	S+180/160		120 AC	30 9 - 14
TXG 8/9	1500	0	23	17	200 - 600	S+180/160		230 AC	30 9 - 14

Type code for accessories

Mains cable	Plug	Country	Order N°	Comment
Straight cable 3.5 m	Euro	General	304330	2-poles
Straight cable 3.5 m	Schuko	DE	304331	2-poles
Straight cable 3.5 m	UL	USA	304332	2-poles
Straight cable 3.5 m	British standard	UK	304333	2-poles
Top or bottom mounting plate			304338	

Ordering key

Type

Motor voltage:

24 V DC	1
120 V AC, 50/60 Hz, class II	4
120 V AC, 50/60 Hz, class I (mandatory for cable feedthrough)	5
230 V AC, 50 Hz, class II	8
230 V AC, 50 Hz, class I (mandatory for cable feedthrough)	9

Output for an additional DC-Motor:

Not used (Stand alone)	0
24 V DC (Master, not available for TXG1)	1

Cable/connecting plug:

Not used	00
----------	----

Colour:

Colourless anodised	5
---------------------	---

Options: (*24 V DC only, **230/120 V AC only)

None	0 0 0
Control connection feedthrough **	EYX
Mains cable feedthrough **	EYF
Encoder for TXG *	EYS
Encoder for other controls*	EXG
Retract, memory**	2CA
Control connection feedthrough**, mains cable feedthrough**	2AA
Retract, memory**, mains cable feedthrough**	3AW
Control connection feedthrough**, retract, memory**	3AY
Control connection feedthrough**, retract, memory**, mains cable feedthrough**	4AG
Extend, retract, memory**, parallel operation of 2 actuators**	4AL
Extend, retract, memory**, parallel operation of 2 actuators**, mains cable feedthrough **	5AA
Extend, retract, memory**, parallel operation of 2 actuators**, control connection feedthrough **	5AC
Extend, retract, memory**, parallel operation of 2 actuators**, control/mains cable feedthrough **	6AA

Stroke (S) / Retr. Length (L = S + 180 or 160 mm):

	L=S+180	L=S+160
200 mm	200	4CY
300 mm	300	4DY
400 mm	400	4EY
500 mm	500	4FY
600 mm	600	4GY

Example: **TXG** **5 1** - **00 5 2AA** - **300 00**

4 Actuation systems

Telescopic pillars

MAGGEAR

With a stroke of 200 mm the MAGGEAR (→ figure 8) is especially suitable to adjust sit-sit workstations. Consisting of a small, strong 24 VDC motor, a gear with spindle and a push tube, the MAGGEAR can directly be integrated into most table legs.

Benefits:

- Small and slim
- In-line layout
- Low cost

Figure 8

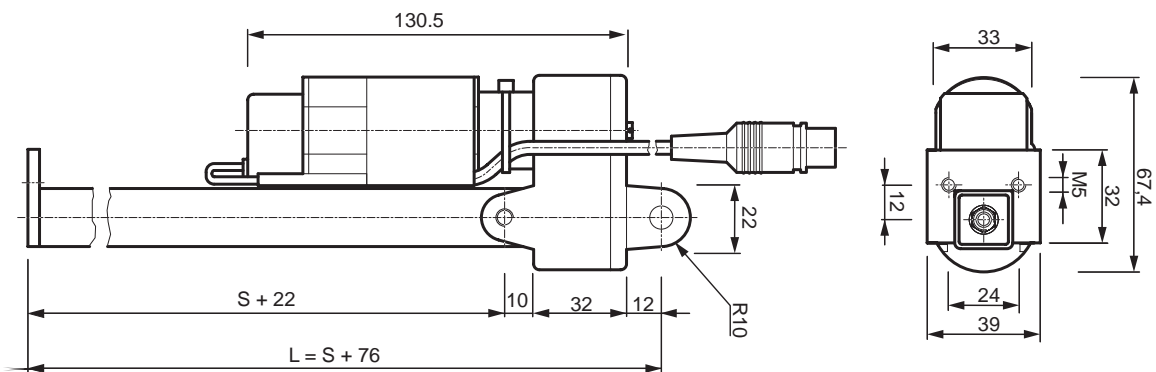
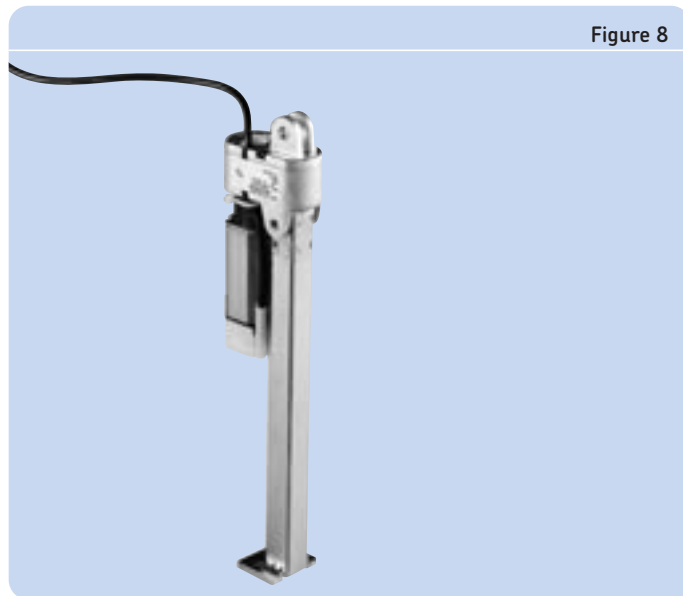

Legend:
S = stroke
L = retracted length

Ordering key

ETE - 815 201

Type

Load / Speed / Stroke (S):

800 N (push) / 8 mm/s / 200 mm 815 201

Type	Force		Max. speed		Stroke (S)	Retr. Length (L)	Voltage	Protection	Weight
	push	pull	no load	full load					
	N		mm/s		mm	mm	V DC	IP	kg
ETE	800	200	8	8	200	S + 76	24	X0	1.0



4 Actuation systems

Linear actuators

Linear actuators

CAT

The CAT (→ **figure 9**) modular design concept makes it easy to interchange critical components such as motors, gears, screws, attachments, etc. Custom built actuators are easily and cost efficiently built from standard parts. The CAT range flexibility makes it suitable for an infinite number of applications.

Benefits:

- Small
- Robust
- Highly efficient
- Maintenance-free

Figure 9



Type	Force		Max. speed		Stroke (S)	Retr. Length* (L)	Voltage	Protection	Weight
	push	pull	no load	full load					
	N		mm/s		mm	mm	V	IP	kg
CAT 21B	600	600	10	5	50 - 300	S+100	12/24 DC	X4	0.7 - 1.5
CAT 33H	1200	1200	174	150	100 - 400	S+150/158/189	12/24 DC 120/230/400 AC	20/44/54/65	2 - 2.7
CAT 33	3000	3000	48	38	100 - 400	S+150/158/189	12/24 DC 120/230/400 AC	20/44/54/65	2 - 2.7
CAT 32B	4000	4000	67	50	50 - 700	S+167/175/206	12/24 DC 120/230/400 AC	20/44/54/65	2 - 3.5

* Dimension depends on selected front attachment

CAT 21B

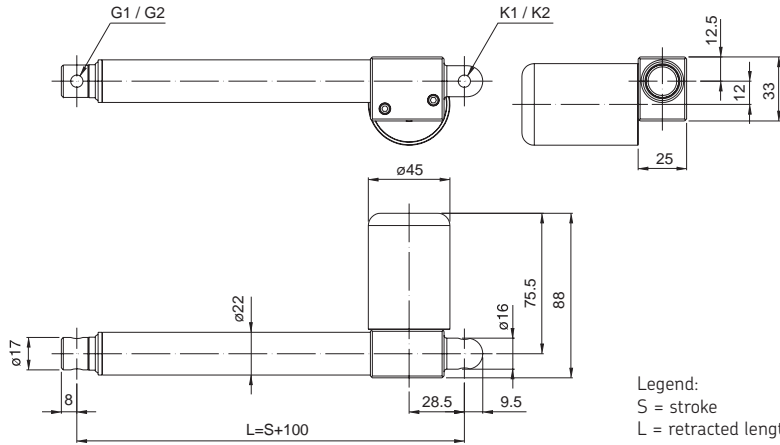

Legend:
S = stroke
L = retracted length

Type	Force		Max. speed		Stroke (S)	Retr. Length (L)	Voltage	Protection	Weight
	push	pull	no load	full load					
	N		mm/s		mm	mm	V DC	IP	kg
CAT 21B	600	600	10	5	50 - 300	S + 100	12/24	X4	0.7 - 1.5

Ordering key



Type

Motor assembly:

Right. R
Left. L

Stroke (S):

50 mm 050
100 mm 100
200 mm 200
300 mm 300
0 < S < 300 mm (S > 300 mm contact SKF) - - -

Rear attachments:

Single ear, hole diameter 6.35 mm K1
Single ear, hole diameter 8 mm K2

Front attachment:

Hole diameter 6.35 mm G1
Hole diameter 8 mm G2

Options:

No friction clutch Z

Motor options:

12 V DC G12C
24 V DC G24C

Options motors:

Cable, 1.6 m, with plug (jack plug, 1/4" 2-pole) P
Cable, 1.6 m, no plug T
Motor without cover N
Encoder E

Example: CAT R 21B × 200 × 1 K1 G1 Z / G24C T

4 Actuation systems

Linear actuators

CAT33H

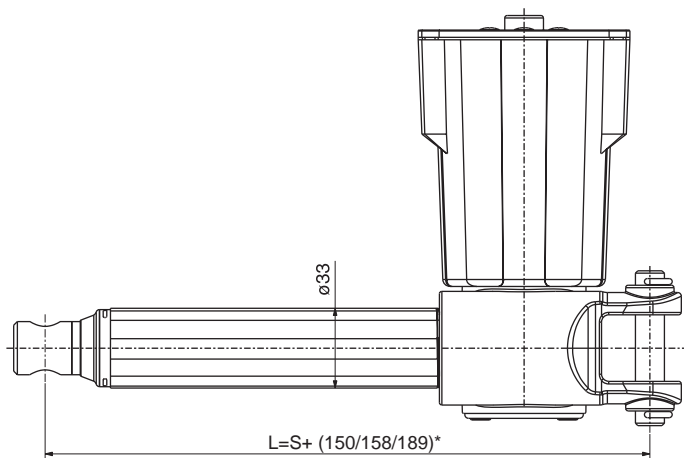

Legend:
 S = stroke
 L = retracted length

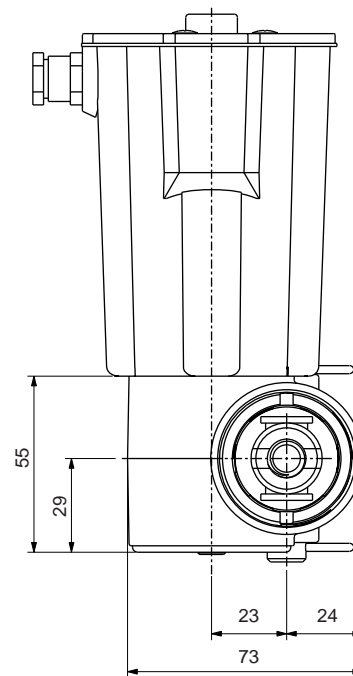

See drawings of front and rear attachments
 and motor options on page 190

Type	Force		Max. speed		Stroke (S)	Retr. Length* (L)	Voltage	Protection	Weight
	push	pull	no load	full load					
	N		mm/s		mm	mm	V	IP	kg
CAT 33H	1200	1200	174	150	100 - 400	S + 150/158/189	12/24 DC 120/230/400 AC	20/44/54/65	2 - 2.7

* Dimension depends on selected front attachment

Ordering key

Dynamic load (N)/ Speed (mm/s)			Motor options	
1200/xx	900/xx	600/xx	No motor	0000
1000/50-38	600/100-80	400/174-150	12 V DC, IP44 (65)	C12C
1000/50-38	600/100-80	400/174-150	12 V DC, flat motor, IP44	D12C
1200/56-36	900/113-79	500/174-140	24 V DC, IP44 (65)	C24C
1200/27-17	800/60-35	500/100-69	24 V DC, low speed, IP44 (65)	C24CW
1200/56-36	900/113-79	500/174-140	24 V DC, flat motor, IP44	D24C
1200/56-36	900/113-79	500/174-140	24 V DC, flat motor, brake, IP20	D24CB
1200/56-36	900/113-79	500/174-140	24 V DC, flat motor, ext. shaft, IP44	D24CS
1200/27-17	800/60-35	500/100-69	24 V DC, flat motor, low speed, IP44	D24CW
1200/20	900/37	600/90	120 V AC/60 Hz, brake, IP54	E110C (25 mF)
1200/20	900/37	600/90	120 V AC/60 Hz, brake, IP20	E110CB (25 mF)
1200/20	900/37	600/90	230 V AC/50 Hz, IP54	E220C
1200/20	900/37	600/90	230 V AC/50 Hz, brake, IP20	E220CB
1200/20	900/37	600/90	230 V AC/50 Hz, IP54	E380C
1	2	4		

CAT 33H × [] × [] [] [] [] / [] []

Type

Motor assembly:

Right R
Left L

Stroke (S):

100 mm 100
200 mm 200
300 mm 300
400 mm 400
100 < S < 400 mm (S > 400 mm contact SKF) --

Rear attachment (see page 190):

Fork ear, Ø 12.0 mm A1
Fork ear, Ø 12.7 mm A2
Single ear, Ø 12.0 mm K1
Single ear, Ø 12.7 mm K2

Front attachment (see page 190):

Hole, Ø 12.0 mm G1
Hole, Ø 12.7 mm G2
Male thread, M12 G3
Female thread, M12 G4
Fork ear, Ø = 10.1 mm G5

Feed back:

Encoder (no code)
Encoder (only for CxxC motors) E
Encoder (for all standard motors) E2

Options:

Friction clutch F
No friction clutch Z

Options for CxxC motors:

No cable U
EMC filter M
Motor without cover N
IP 65 (mandatory to state type of cable T2 or T2P) I
Straight cable, 2.0 m, no plug T2
Straight cable, 2.0 m, jack plug T2P

Example: CAT L 33H × 400 × 4 A1 G5 E F / C24C T2P

4 Actuation systems

Linear actuators

CAT 33

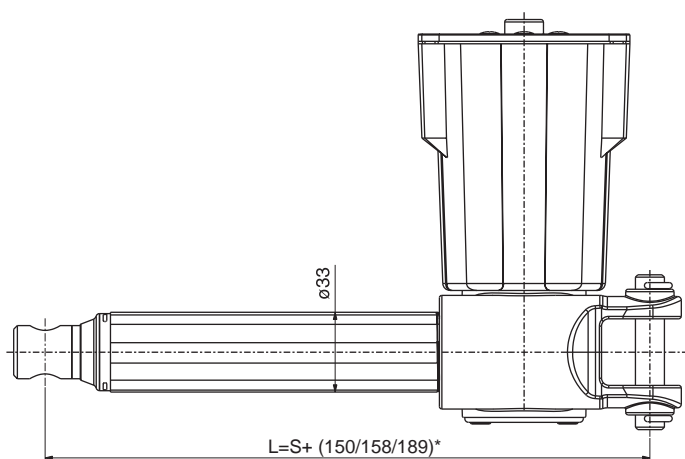

Legend:
 S = stroke
 L = retracted length

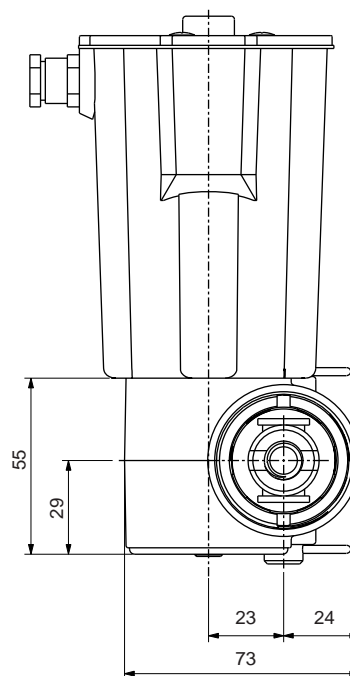

See drawings of front and rear attachments
 and motor options on page 190

Type	Force		Max. speed		Stroke (S)	Retr. Length* (L)	Voltage	Protection	Weight
	push	pull	no load	full load					
	N		mm/s		mm	mm	V	IP	kg
CAT33	3000	3000	48	38	100 - 400	S + 150/158/189	12/24 DC 120/230/400 AC	20/44/54/65	2 - 2.7

* Dimension depends on selected front attachment

Ordering key

Dynamic load (N)/ Speed (mm/s)			Motor options	
3000/xx	2000/xx	1000/xx	No motor	0000
3000/13-10	2000/24-20	1000/48-38	12 V DC, IP44 (65)	C12C
2400/11-7	1600/21-15	800/39-21	12 V DC, flat motor, IP44	D12C
3000/13-10	2000/26-20	1000/48-35	24 V DC, IP44 (65)	C24C
3000/7-5	2000/13-8	1000/26-19	24 V DC, low speed, IP44 (65)	C24CW
3000/13-10	2000/26-20	1000/48-35	24 V DC, flat motor, IP44	D24C
3000/13-10	2000/26-20	1000/48-35	24 V DC, flat motor, IP44, extended shaft	D24CS
3000/7-5	2000/13-8	1000/26-19	24 V DC, flat motor, low speed, IP44	D24CW
2400/6	1600/12	800/24	120 V AC/60 Hz, IP54	E110C
2400/6	1600/12	800/24	120 V AC/60 Hz, brake, IP20	E110C
3000/5	2000/10	1000/20	230 V AC/50 Hz, IP54	E220C
3000/5	2000/10	1000/20	230 V AC/50 Hz, brake, IP20	E220CB
3000/5	2000/10	1000/20	400 V AC/50 Hz, IP54	E380C
1	2	4		

CAT	L	33	×		×		/		
-----	---	----	---	--	---	--	---	--	--

Type

Motor assembly:

Right R

Left L

Stroke (S):

100 mm 100

200 mm 200

300 mm 300

400 mm 400

100 < S < 400 mm (S > 400 mm contact SKF) - - -

Rear attachment (see page 190):

Fork ear, Ø 12.0 mm A1

Fork ear, Ø 12.7 mm A2

Single ear, Ø 12.0 mm K1

Single ear, Ø 12.7 mm K2

Front attachment (see page 190):

Hole, Ø 12.0 mm G1

Hole, Ø 12.7 mm G2

Male thread, M12 G3

Female thread, M12 G4

Fork ear, Ø = 10.1 mm G5

Feed back:

Encoder (no code)

Encoder (only for CxxC motors) E

Encoder (for all standard motors) E2

Options:

Friction clutch F

No friction clutch Z

Options for CxxC motors:

No cable U

EMC filter M

Motor without cover N

IP 65 (mandatory to state type of cable T2 or T2P) I

Straight cable, 2.0 m, no plug T2

Straight cable, 2.0 m, jack plug T2P

Example:

CAT	L	33
-----	---	----

 ×

200

 ×

1	A1	G1	E2	Z
---	----	----	----	---

 /

C24C	T2P
------	-----

4 Actuation systems
Linear actuators

CAT32B

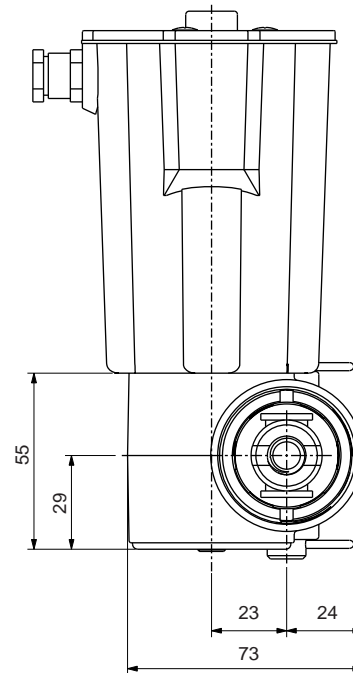
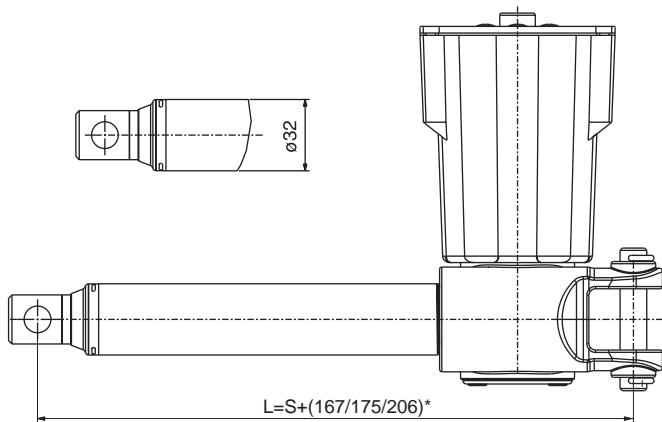

Legend:
S = stroke
L = retracted length

*See drawings of front and rear attachments
and motor options on page 190*

Type	Force		Max. speed		Stroke (S)	Retr. Length* (L)	Voltage	Protection	Weight
	push	pull	no load	full load					
	N		mm/s		mm	mm	V	IP	kg
CAT 32B	4000	4000	67	50	50 - 700	S + 167/175/206	12/24 DC 120/230/400 AC	20/44/54/65	2 - 3.5

* Dimension depends on selected front attachment

Ordering key

Dynamic load (N)/ Speed (mm/s)			Motor options	
4000/xx	2500/xx	1500/xx	No motor	0000
4000/17-12	2500/32-25	1500/63-48	12 V DC, IP44 (65)	C12C
3000/17-11	2000/34-19	1000/67-43	12 V DC, flat motor, IP44	D12C
4000/17-13	2500/33-24	1500/65-50	24 V DC, IP44 (65)	C24C
4000/9-5	2500/18-10	1500/34-24	24 V DC, low speed motor, IP44	C24CW
4000/17-13	2500/33-24	1500/65-50	24 V DC, flat motor, IP44	D24C
4000/17-13	2500/33-24	1500/65-50	24 V DC, flat motor, brake, IP20	D24CB
4000/17-13	2500/33-24	1500/65-50	24 V DC, flat motor, extended shaft, IP44	D24CS
4000/9-5	2500/18-10	1500/34-24	24 V DC, flat motor, low speed, IP44	D24CW
3500/8	2100/16	1300/32	120 V AC/60 Hz, IP54	E110C
3500/8	2100/16	1300/32	120 V AC/60 Hz, brake, IP20	E110CB
3500/6.5	2100/13	1300/26	230 V AC/50 Hz, IP54	E220C
3500/6.5	2100/13	1300/26	230 V AC/50 Hz, brake, IP20	E220CB
3500/6.5	2100/13	1300/26	400 V AC/50 Hz, IP54	E380C
1	2	4		

CAT 32 B × × /

Type

Motor assembly:
 Right R
 Left L

Stroke (S):
 50 mm 50
 100 mm 100
 200 mm 200
 300 mm 300
 400 mm 400
 500 mm 500
 700 mm 700
 50 < S < 700 mm (S > 700 mm contact SKF)..... ---

Rear attachment (see page 190):
 Fork ear, Ø 12.0 mm A1
 Fork ear, Ø 12.7 mm A2
 Single ear, Ø 12.0 mm K1
 Single ear, Ø 12.7 mm K2

Front attachment (see page 190):
 Hole, Ø 12.0 mm G1
 Hole, Ø 12.7 mm G2
 Male thread, M12 G3
 Female thread, M12 G4
 Fork ear, Ø 10.1 mm G5

Feed back:
 Encoder (no code)
 Encoder (only for CxxC motors) E
 Encoder (for all standard motors) E2

Options:
 Friction clutch F
 No friction clutch Z
 Back-up ball nut S

Options for CxxC motors:
 No cable U
 EMC filter M
 Motor without cover N
 IP 65 (mandatory to state type of cable) I
 Straight cable, 2.0 m, no plug T2
 Straight cable, 2.0 m, jack plug T2P

Example: CAT L 32 B × 400 × 2 A1 G3 F / C24C T2P

Front attachments and retracted length

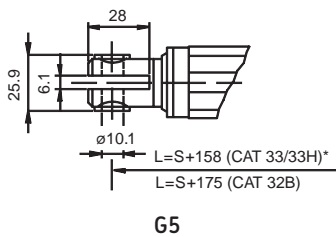
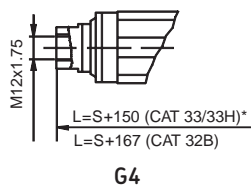
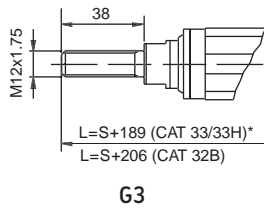
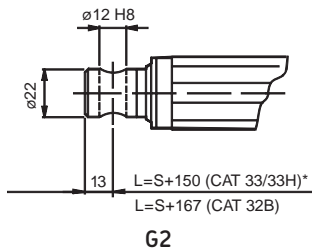
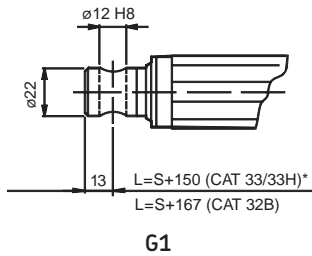

Motors

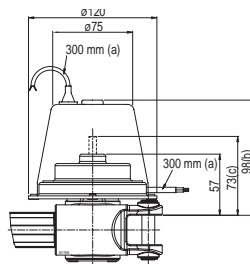

D12C, D24C, D24CB, D24CS, D24CW

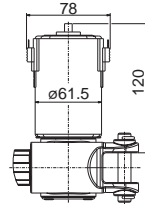

C12CN, C24CN, C24CWN

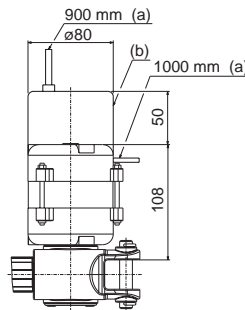

E110C, E110CB, E220C, E220CB

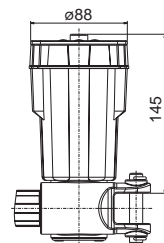

C12CM, C12CME, C24CM, C24CME, C24CWM, C24CWME

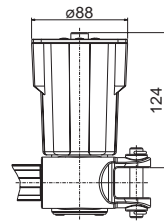

C12C, C24C, C24CW

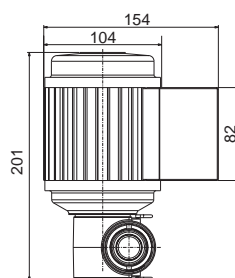

E380C

Rear attachments

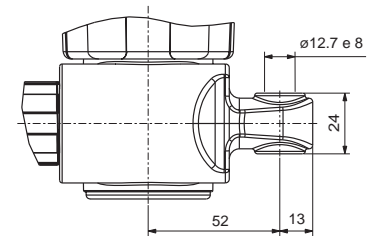
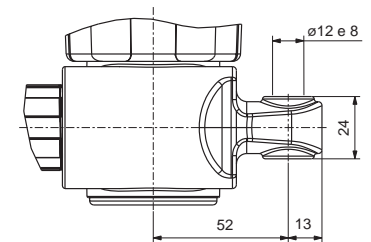
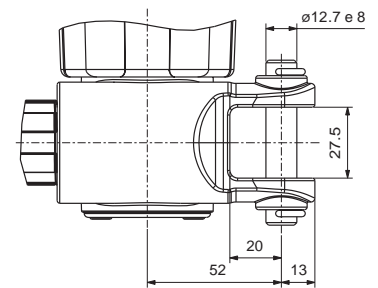
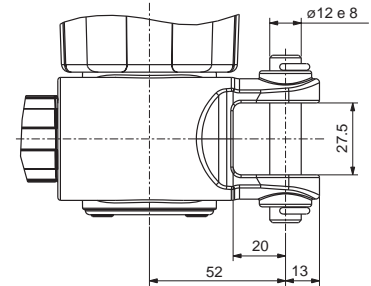

Legend:
(a) = Cable length
(b) = Cover for brake
S = stroke
L = retracted length

* If S = 400 add 50 mm to retracted length



4 Actuation systems

Linear actuators

CAP

The base for CAP positioning actuator series (→ **figure 10**) is the existing CAR linear actuator series and CAT modular range with a vast number of possibilities such as motors, front and rear attachments etc. Positioning accuracy and service life is ensured by detecting the position directly on the moving nut and by keeping the moving parts to a minimum.

Benefits:

- Easy installation
- Robust and reliable
- Maintenance-free
- Left and right hand versions

Figure 10

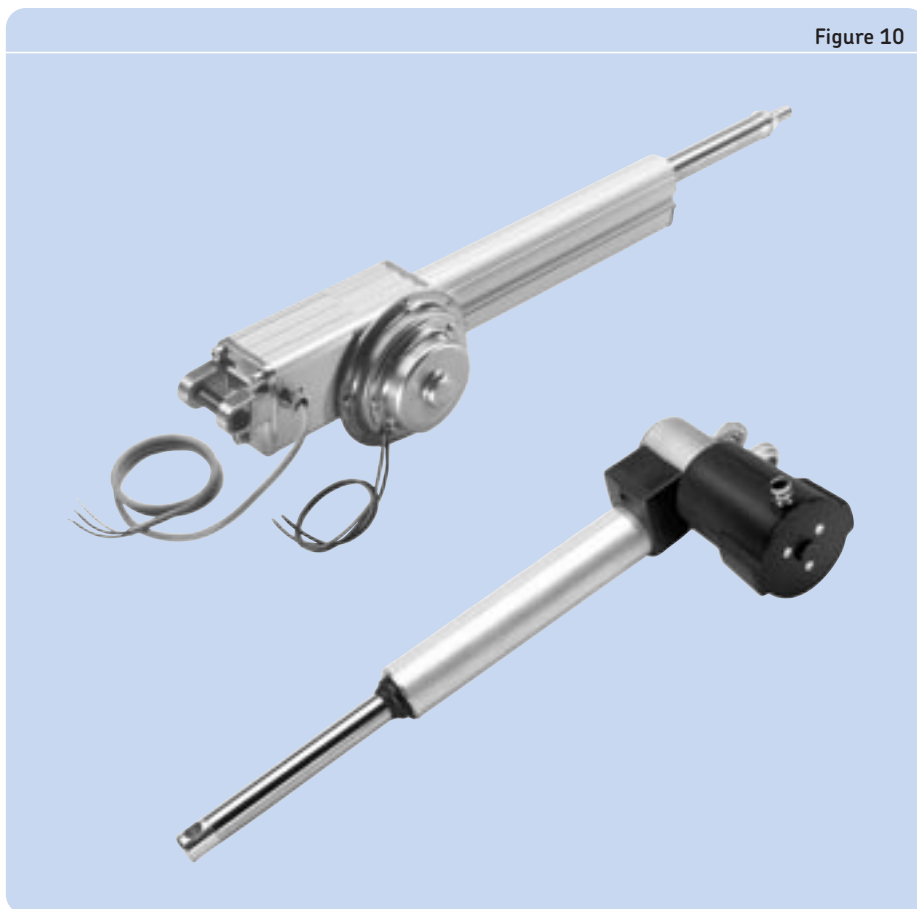

Type	Force		Max. speed		Stroke (S)	Retr. Length* (L)	Voltage	Protection	Weight
	push	pull	no load	full load					
	N		mm/s		mm	mm	V	IP	kg
CAP 32	3500	3500	60	40	50 - 700	S + 301	12/24 DC 120/230 AC	20/44/54	2.9 - 5.0
CAP 43A	3000	3000	48	35	100 - 400	S + 150/158/189	24 DC	44/65	2.0 - 2.7
CAP 43B	4000	4000	65	50	50 - 700	S + 167/175/206	24 DC	44/65	2.0 - 3.5

* Dimension depends on selected front attachment

CAP 32

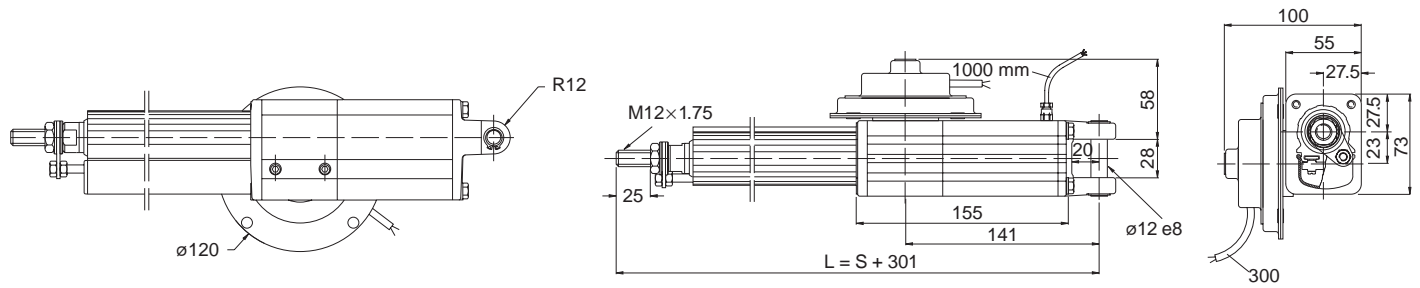

Legend:
 S = stroke
 L = retracted length

See drawings of front and rear attachments and motor options on page 196

Type	Force		Max. speed		Stroke (S)	Retr. Length* (L)	Voltage	Protection	Weight
	push	pull	no load	full load					
	N		mm/s		mm	mm	V	IP	kg
CAP 32	3500	3500	60	40	50 - 700	S + 301	12/24 DC 120/230 AC	20/44/54	2.9 - 5.0

* Dimension depends on selected front attachment

Ordering key

Dynamic load (N)/Speed (mm/s)			Motor options	
3500/xx	2500/xx	1500/xx	No motor	0000
2500/15-10	2000/30-20	1000/60-40	12 V DC, flat motor, IP44	D12C
3500/15-10	2500/30-20	1500/60-40	24 V DC, flat motor, IP44	D24C
3500/9-5	2500/18-10	1500/34-24	24 V DC, flat motor, low speed, IP44	D24CW
3500/15-10	2500/30-20	1500/60-40	24 V DC, flat motor, extended shaft, IP44	D24CS
3500/15-10	2500/30-20	1500/60-40	24 V DC, flat motor, brake, IP20	D24CB
3500/8	2500/16	1500/32	120 V AC/60 Hz, single phase, IP54	E110C
3500/8	2500/16	1500/32	120 V AC/60 Hz, single phase, brake, IP20	E110CB
3500/6	2500/13	1500/26	230 V AC/50 Hz, single phase, IP54	E220C
3500/6	2500/13	1500/26	230 V AC/50 Hz, single phase, brake, IP20	E220CB
1	2	4		

Type

Motor assembly:
 Right R
 Left L

Stroke (S):
 50 mm 050
 100 mm 100
 200 mm 200
 300 mm 300
 500 mm 500
 700 mm 700
 50 < S < 700 mm (S > 700 mm contact SKF) - - -

Options:
 Back-up nut S

Example: CAP R 32 × 500 × 2 S / E220CB

4 Actuation systems

Linear actuators

CAP 43A

Legend:
 S = stroke
 L = retracted length
 (a) = cable length

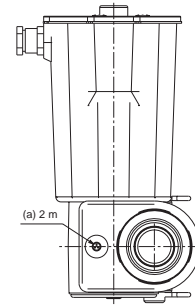
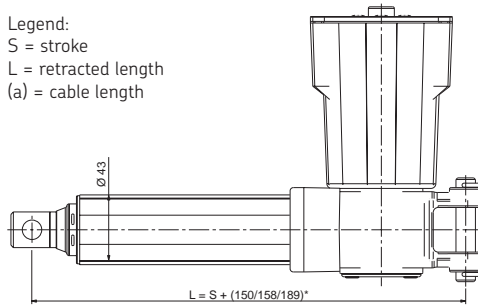

See drawings of front and rear attachments and motor options on page 196

Type	Force		Max. speed		Stroke (S)	Retr. Length* (L)	Voltage	Protection	Weight
	push	pull	no load	full load					
	N		mm/s		mm	mm	V DC	IP	kg
CAP 43A	3000	3000	48	35	100 - 400	S + 150/158/189	24	44/65	2 - 2.7

* Dimension depends on selected front attachment

Ordering key

Dynamic load (N)/Speed (mm/s)			Motor options	
3000/xx	2000/xx	1000/xx	No motor	0000
3000/7-5	2000/13-8	1000/26-19	24 V DC, IP44(65)	C24CW
3000/7-5	2000/13-8	1000/26-19	24 V DC, flat motor, low speed, IP44	D24CW
3000/13-10	2000/26-20	1000/48-35	24 V DC, IP44(65)	C24C
3000/13-10	2000/26-20	1000/48-35	24 V DC, flat motor, IP44	D24C
1	2	4		

CAP 43A × [] × [] [] F / [] [] [] [] [] []

Type

Motor assembly:

Right R
 Left L

Stroke (S):

100 mm 100
 200 mm 200
 300 mm 300
 400 mm 400

Rear attachment (see page 196):

Fork ear, Ø 12.0 mm A1
 Fork ear, Ø 12.7 mm A2
 Single ear, Ø 12.0 mm K1
 Single ear, Ø 12.7 mm K2

Front attachment (see page 196):

Hole, Ø 12.0 mm G1
 Hole, Ø 12.7 mm G2
 Male thread, M12 G3
 Female thread, M12 G4
 Fork ear, Ø 10.1 mm G5

Options:

Friction clutch F

Cable options for C24C(W) motors:

No cable U
 Straight, 2.0 m T2

Options for motor:

EMC filter M

Options motor protection:

Motor without cover N
 Protection class IP 65 (always order motor cable when selecting IP65) I

Example: CAP R 43A × 300 × 1 A1 G2 F / C24CW T2 M N I

CAP 43B

Legend:
 S = stroke
 L = retracted length
 (a) = cable length

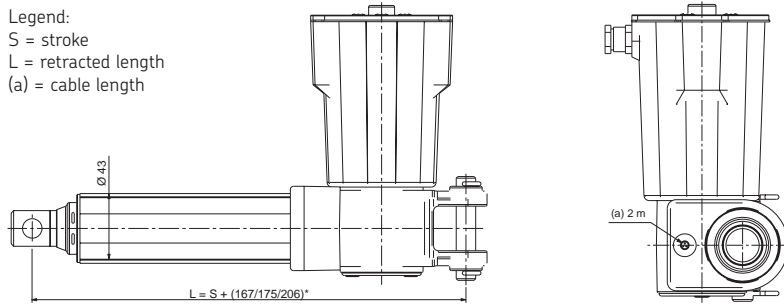

See drawings of front and rear attachments and motor options on page 196

Type	Force		Max. speed		Stroke (S)	Retr. Length* (L)	Voltage	Protection	Weight
	push	pull	no load	full load					
	N		mm/s		mm	mm	V DC	IP	kg
CAP 43B	4000	4000	65	50	50 - 700	S + 167/175/206	24	44/65	2 - 3.5

* Dimension depends on selected front attachment

Ordering key

Dynamic load (N)/Speed (mm/s)			Motor options	
4000/xx	2500/xx	1500/xx	No motor	0000
4000/17-13	2500/33-24	1500/65-50	24 V DC, IP44 (65)	C24C
4000/9-5	2500/18-10	1500/34-24	24 V DC, low speed, IP44 (65)	C24CW
4000/17-13	2500/33-24	1500/65-50	24 V DC, flat motor, IP44	D24C
4000/9-5	2500/18-10	1500/34-24	24 V DC, flat motor, low speed, IP44	D24CW
1	2	4		

Type

Motor assembly:
 Right R
 Left L

Stroke (S):
 50 mm 50
 100 mm 100
 200 mm 200
 300 mm 300
 400 mm 400
 500 mm 500
 700 mm 700

Rear attachment (see page 196):
 Fork ear, Ø 12.0 mm A1
 Fork ear, Ø 12.7 mm A2
 Single ear, Ø 12.0 mm K1
 Single ear, Ø 12.7 mm K2

Front attachment (see page 196):
 Hole, Ø 12.0 mm G1
 Hole, Ø 12.7 mm G2
 Male thread, M12 G3
 Female thread, M12 G4
 Fork ear, Ø 10.1 mm G5

Options:
 Friction clutch F
 Back-up nut S

Cable options for C24C(W) motors:
 No cable U
 Straight, 2.0 m T2

Options for motor:
 EMC filter M

Options motor protection:
 Motor without cover N
 Protection class IP 65 (always order motor cable when selecting IP65) I

Example: **CAP L 43B** × **50** × **2 A1 G2 S** / **D24CW T2 M I**

Detailed drawings of attachments and motor options for CAP 43 and motor options for CAP 32

Front attachments and retracted length

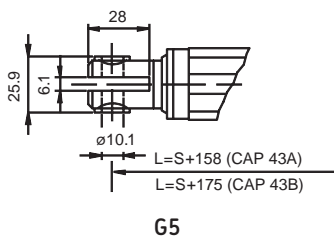
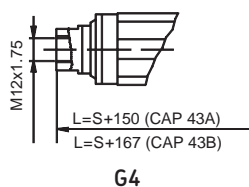
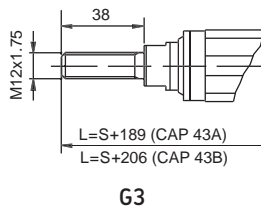
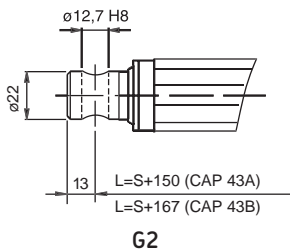
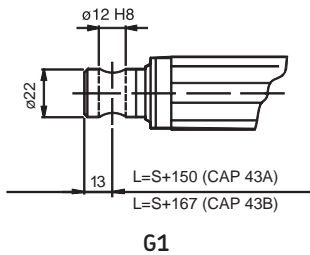

Motor options CAP 43

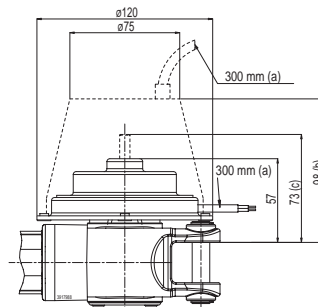

D24C, D24CW

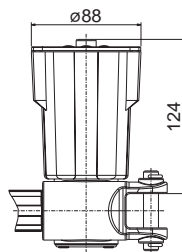

C24C, C24CW

Motor options CAP 32

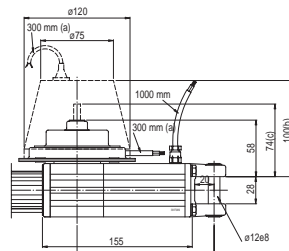

D12C, D24C, D24CW, D24CS, D24CB

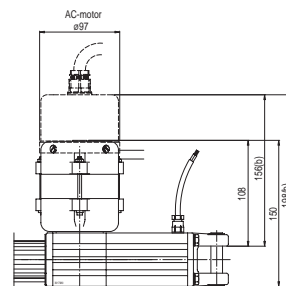

E110CB, E220CB, E110C, E220C

Rear attachments

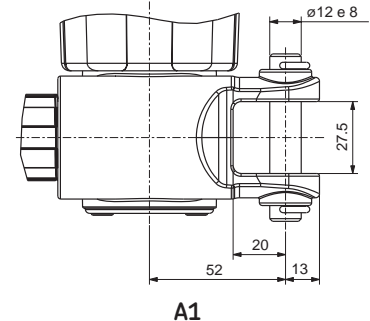

A1

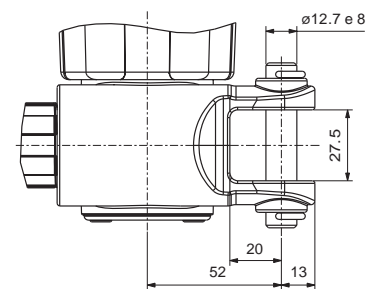

A2

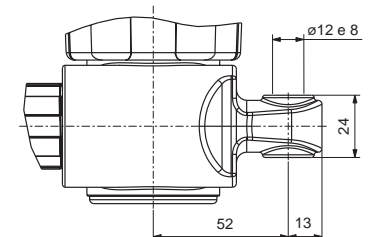

K1

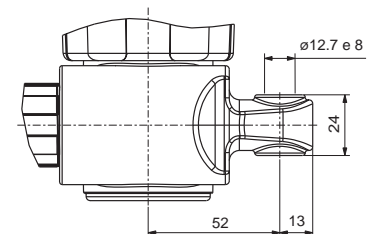

K2

Legend:
(a) = Cable length
(b) = Cover for brake (D24CB)
(c) = D24CS version
S = stroke
L = retracted length

CAR

The CAR range (→ **figure 11**) of industrial type actuators offers a unique standard of performance, durability, and reliability. The compact design incorporates well-proven parts, like the SKF high efficiency ball screw, a sturdy gearbox assembly, and high quality DC and AC-motors. All to give the best performance possible with extensive operational life. Individual application requirements can easily be matched thanks to the modular design concept.

Benefits:

- Robust and reliable
- Long life time
- Wide component range
- Left and right hand versions

Figure 11

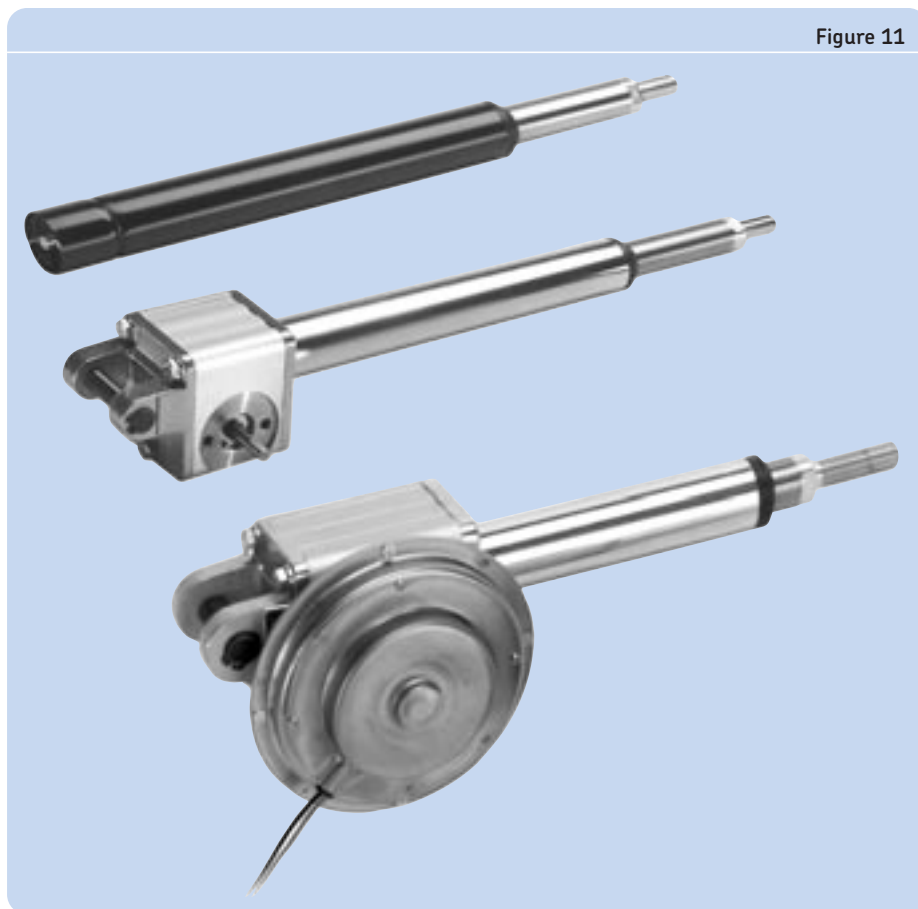

4

Type	Force		Max. speed		Stroke (S)	Retr. Length* (L)	Voltage	Protection	Weight
	push	pull	no load	full load					
	N		mm/s		mm	mm	V	IP	kg
CAR 22	1500	1500	30	20	50 - 300	S + 205	12/24 DC	44	1.2 - 1.6
CAR 32	3500	3500	60	40	50 - 700	S + 218	12/24 DC 120/230 AC	20/44/54	2.1 - 3.7
CAR 40	6000	6000	60	40	100 - 700	S + 263	12/24 DC 120/230 AC	20/44/54	5.8 - 8.4
CARN 32	3500	3500	N/A	N/A	50 - 700	S + 218	N/A	N/A	0.8 - 3.3
CCBR 32	2500	2500	N/A	N/A	50 - 700	S + 177	N/A	N/A	1.1 - 1.5

* Dimension depends on selected front attachment

4 Actuation systems

Linear actuators

CAR 22

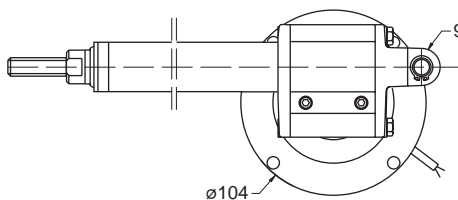
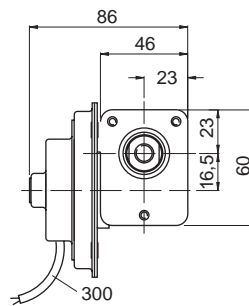
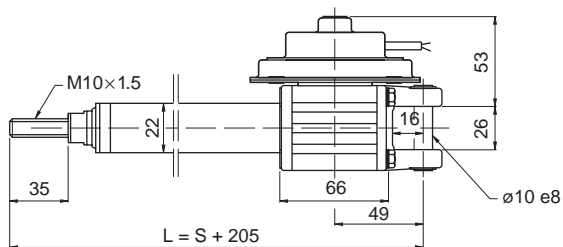

Legend:
S = stroke
L = retracted length

Type	Force		Max. speed		Stroke (S)	Retr. Length (L)	Voltage	Protection	Weight
	push	pull	no load	full load					
	N		mm/s		mm	mm	V	IP	kg
CAR 22	1500	1500	30	20	50 - 300	S + 205	12/24 DC	44	1.2 - 1.6

Ordering key

Dynamic load (N)/ Speed (mm/s)		Motor options	
1500/xx	1000/xx	No motor	0000
1500/15-10	1000/30-20	12 V DC, flat motor, IP44	D12B
1500/15-10	1000/30-20	24 V DC, flat motor, IP44	D24B
1	2		

Type

Motor assembly:

Right R
Left L

Stroke (S):

50 mm 050
100 mm 100
150 mm 150
200 mm 200
300 mm 300
50 < S < 300 (> 300 mm contact SKF) - - -

CAR 22 × [] × [] / []

Example: CAR L 22 × 50 × 1 / D24B

CAR 32

Legend:
 S = stroke
 L = retracted length
 (a) = Cable length
 (b) = Cover for brake (D24CB)
 (c) = D24CS version

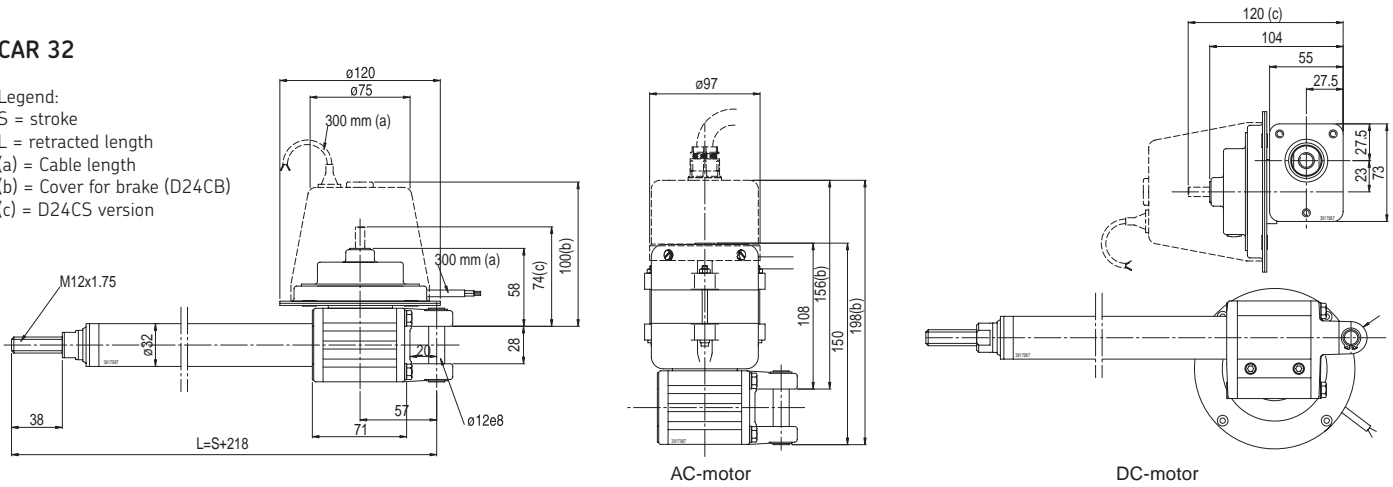

Type	Force		Max. speed		Stroke (S)	Retr. Length (L)	Voltage	Protection	Weight
	push	pull	no load	full load					
	N		mm/s		mm	mm	V	IP	kg
CAR 32	3500	3500	60	40	50 - 700	S + 218	12/24 DC 120/230 AC	20/44/54	2.1 - 3.7

Ordering key

Dynamic load (N)/Speed (mm/s)			Motor options	
3500/xx	2500/xx	1500/xx	No motor	0000
2500/15-10	2000/30-20	1000/60-40	12 V DC, flat motor, IP44	D12C
3500/15-10	2500/30-20	1500/60-40	24 V DC, flat motor, IP44	D24C
3500/9-5	2500/18-10	1500/34-24	24 V DC, flat motor, low speed, IP44	D24CW
3500/15-10	2500/30-20	1500/60-40	24 V DC, flat motor, extended shaft, IP44	D24CS
3500/15-10	2500/30-20	1500/60-40	24 V DC, flat motor, brake, IP20	D24CB
3500/8	2500/16	1500/32	120 V AC/60Hz, single phase, IP54	E110C
3500/8	2500/16	1500/32	120 V AC/60Hz, single phase, brake, IP20	E110CB
3500/6	2500/13	1500/26	220 V AC/50Hz, single phase, IP54	E220C
3500/6	2500/13	1500/26	220 V AC/50Hz, single phase, brake, IP20	E220CB
1	2	4		

Type

Motor assembly:

Right R
 Left L

Stroke (S):

50 mm 50
 100 mm 100
 200 mm 200
 300 mm 300
 500 mm 500
 700 mm 700
 50 < S < 700 mm (> 700 mm contact SKF). - - -

Options:

Friction clutch F
 Back-up nut S

CAR 32 × [] × [] / []

Example: **CAR R 32** × **500** × **2** / **F E220CB**

4 Actuation systems

Linear actuators

CAR 40

Legend:
 S = stroke
 L = retracted length
 (a) = Cable length
 (b) = Cover for brake (D24CB)
 (c) = D24CS version

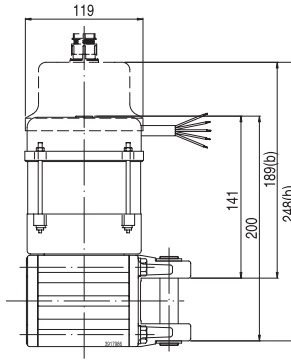
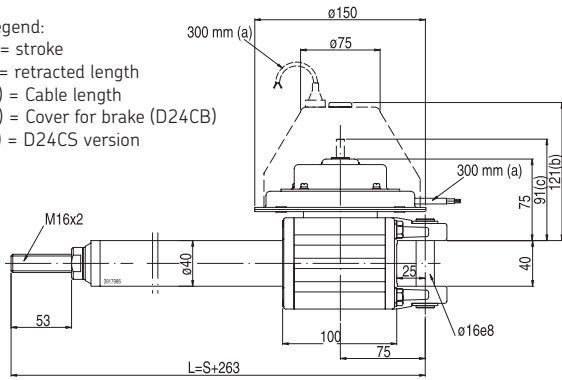

AC-motor

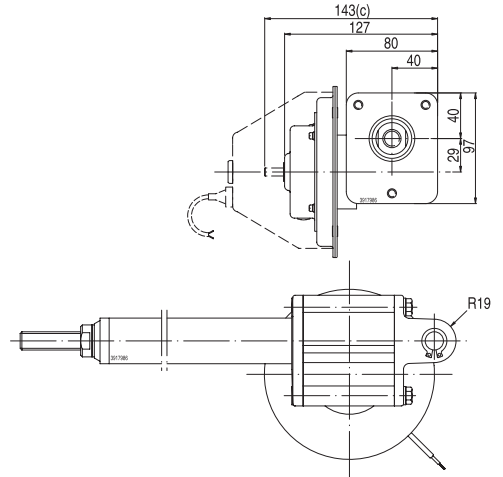

DC-motor

Type	Force		Max. speed		Stroke (S)	Retr. Length (L)	Voltage	Protection	Weight
	push	pull	no load	full load					
	N		mm/s		mm	mm	V	IP	kg
CAR 40	6000	6000	60	40	100 - 700	S + 263	12/24 DC 120/230 AC	20/44/54	5.8 - 8.4

Ordering key

Dynamic load (N)/Speed (mm/s)			Motor options	
6000/xx	4000/xx	2000/xx	No motor	
6000/15-10	4000/30-20	2000/60-40	24 V DC, flat motor, IP44	
6000/15-10	4000/30-20	2000/60-40	24 V DC, flat motor, extended shaft, IP44	
6000/15-10	4000/30-20	2000/60-40	24 V DC, flat motor, brake, IP20	
6000/10	4000/20	2000/40	120 V AC/60Hz, single phase, IP54	
6000/10	4000/20	2000/40	120 V AC/60Hz, single phase, brake, IP20	
6000/9	4000/17	2000/34	220 V AC/50Hz, single phase, IP54	
6000/9	4000/17	2000/34	220 V AC/50Hz, single phase, brake, IP20	
1	2	4		0000 D24D D24DS D24DB E110D E110DB E220D E220DB

Type

Motor assembly:

Right R
 Left L

Stroke (S):

100 mm 100
 300 mm 300
 500 mm 500
 700 mm 700
 50 < S < 700 (S > 700 mm contact SKF) - -

Options:

Friction clutch F
 Back-up nut S

CAR 40 × [] × [] / []

Example: **CAR R 40** × **700** × **2** / **F D24CB**

CARN 32

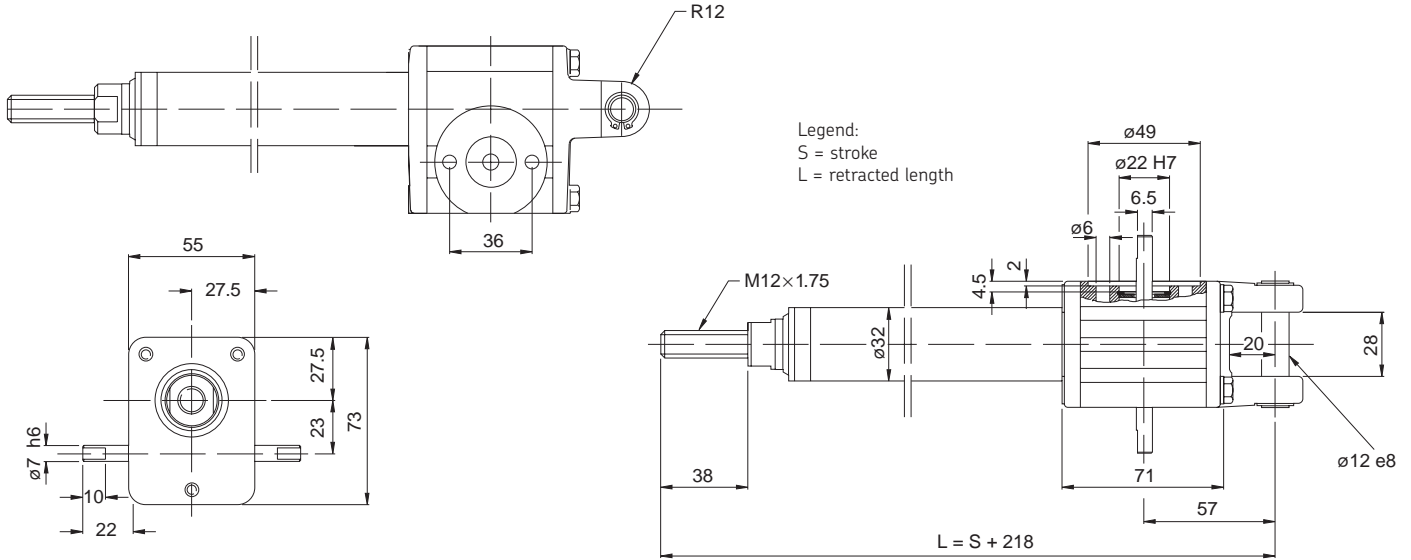

Type	Force		Max. speed		Stroke (S)	Retr. Length (L)	Voltage	Protection	Weight
	push	pull	no load	full load					
	N		mm/s		mm	mm	V	IP	kg
CARN 32	3500	3500	N/A	N/A	50 - 700	S + 218	N/A	N/A	0.8-3.3

Ordering key

CARN 32 × [] × [] / []

Type

Stroke (S):

50 mm	050
100 mm	100
200 mm	200
300 mm	300
500 mm	500
700 mm	700
50 < S < 700 mm (S > 700 mm contact SKF)	- - -

Gear ratio:

25 : 1	1
12.5 : 1 (max. force 2500 N)	2
6.25 : 1 (max. force 1500 N)	4

Options:

Friction clutch	F
Back-up nut	S

Example: CARN 32 × 200 × 2 / S

4 Actuation systems

Linear actuators

CCBR 32

Legend:
S = stroke
L = retracted length

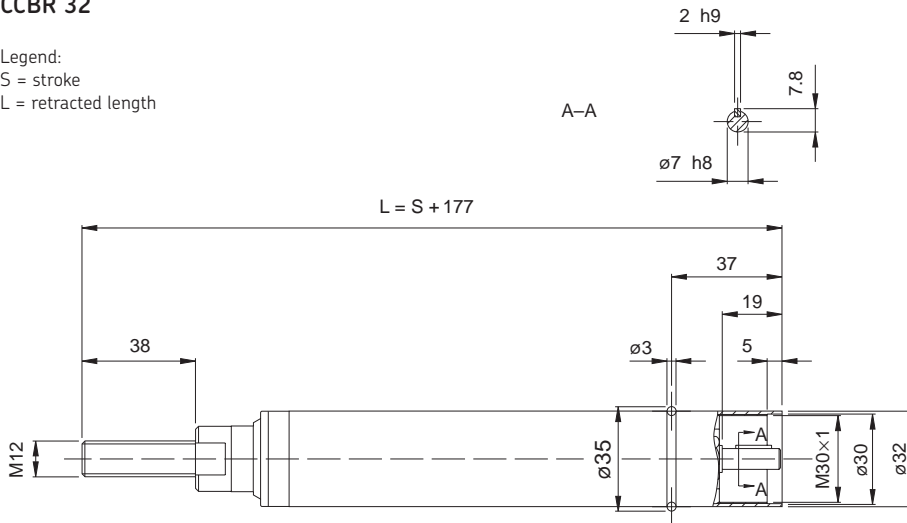

Type	Force		Max. speed		Stroke (S)	Retr. Length (L)	Voltage	Protection	Weight
	push	pull	no load	full load					
	N		mm/s		mm	mm	V	IP	kg
CCBR 32	2500	2500	N/A	N/A	50 - 700	S + 177	N/A	N/A	1.1-1.5

Ordering key

CCBR 32 ×

Type

Stroke (S):

50 mm	050
100 mm	100
200 mm	200
300 mm	300
500 mm	500
700 mm	700
50 < S > 700 mm (S > 700 mm contact SKF)	- - -

Example: CCBR 32 × 200

MAGFORCE

The MAGFORCE line consists of spindle lifting drives with worm gears (→ figure 12). They fulfil the highest demands for industrial and other applications. The drives are available in several different motor versions.

MAGFORCE offers strong, fast and quiet movements with high safety and duty cycle. The drives include many interface options as hall encoder, end switch, extended shaft etc.

Benefits:

- Ideal for heavy load applications
- Wide speed/force range
- Robust design

Figure 12

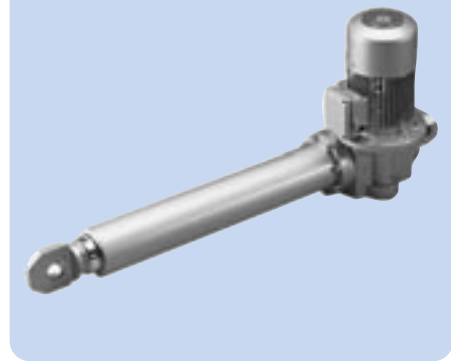

Type	Force		Max. speed		Stroke (S)	Retr. Length (L)	Voltage	Protection	Weight
	push	pull	no load	full load					
	N		mm/s		mm	mm	V	IP	kg
WSP 0510	500	500	68	57	100 - 700	S + 230	230 AC	54	5.7
WSP 1030	1000	1000	23	19	100 - 700	S + 230	230 AC	54	5.7
WSP 1550	1500	1500	13	11	100 - 700	S + 230	230 AC	54	5.7
WSP 2650	2600	2600	7	5	100 - 700	S + 230	230 AC	54	5.7
STW 5007	5000	5000	14	12	100 - 700	S + 273	230 AC	54	14.6
STW 7010	7000	7000	10	8	100 - 700	S + 273	230 AC	54	14.6
STW 10020	10000	10000	5	4	100 - 700	S + 273	230 AC	54	14.6
STW 15040	15000	15000	2	2	100 - 700	S + 273	230 AC	54	14.6
DSP 1010	1000	1000	62	52	100 - 700	S + 230	3 × 400 AC	54	5.6
DSP 2530	2500	2500	20	17	100 - 700	S + 230	3 × 400 AC	54	5.6
DSP 3250	3200	3200	12	10	100 - 700	S + 230	3 × 400 AC	54	5.6
DSP 4550	4500	4500	6	5	100 - 700	S + 230	3 × 400 AC	54	5.6
STD 10007	10000	10000	12	10	100 - 700	S + 273	3 × 400 AC	54	16.3
SKD 10007	10000	10000	30	25	100 - 700	S + 406	3 × 400 AC	54	14.6
SKD 12010	12000	12000	25	21	100 - 700	S + 406	3 × 400 AC	54	14.6
STD 12010	12000	12000	9	8	100 - 700	S + 273	3 × 400 AC	54	16.3
SKD 15020	15000	15000	13	11	100 - 700	S + 406	3 × 400 AC	54	14.6
SKD 15040	15000	15000	6	5	100 - 700	S + 406	3 × 400 AC	54	14.6
STD 15040	15000	15000	3	2	100 - 700	S + 273	3 × 400 AC	54	16.3
STD 15020	15000	15000	5	4	100 - 700	S + 273	3 × 400 AC	54	16.3
SK (S/A) 15404	15000	15000	54	45	100 - 700	S + 465	3 × 400 AC	54	30.0
SLS 18006	18000	18000	88	74	100 - 700	S + 446	3 × 400 AC	54	40.0
SK (S/A) 20406	20000	20000	41	34	100 - 700	S + 465	3 × 400 AC	54	30.0
SK (S/A) 25412	25000	25000	20	17	100 - 700	S + 465	3 × 400 AC	54	30.0
SK (S/A) 30423	30000	30000	11	10	100 - 700	S + 465	3 × 400 AC	54	30.0
SLS 34013	34000	34000	43	36	100 - 700	S + 446	3 × 400 AC	54	40.0
SLS 50020	50000	50000	27	23	100 - 700	S + 446	3 × 400 AC	54	40.0
SLS 50028	50000	50000	19	16	100 - 700	S + 446	3 × 400 AC	54	40.0
SLS 50050	50000	50000	11	9	100 - 700	S + 446	3 × 400 AC	54	40.0
ASM 1010	1000	1000	58	48	100 - 700	S + 230	12/24 DC	44	5.0
ASM 2030	2000	2000	22	18	100 - 700	S + 230	12/24 DC	44	5.0
ASM 3030	3000	3000	10	8	100 - 700	S + 230	12/24 DC	44	5.0
ASM 4050	4000	4000	6	5	100 - 700	S + 230	12/24 DC	44	5.0
GTD 0220	200	200	30	25	50 - 300	S + 99	24 DC	00	0.9
SKG 6005	6000	6000	66	55	100 - 700	S + 406	24 DC	54	14.6
STG 10007	10000	10000	17	14	100 - 700	S + 273	24 DC	54	14.6
SKG 10010	10000	10000	36	30	100 - 700	S + 406	24 DC	54	14.6
STG 12010	12000	12000	13	11	100 - 700	S + 273	24 DC	54	14.6
SKG 13020	13000	13000	18	15	100 - 700	S + 406	24 DC	54	14.6
SKG 15040	15000	15000	10	8	100 - 700	S + 406	24 DC	54	14.6
STG 15040	15000	15000	4	3	100 - 700	S + 273	24 DC	54	14.6
STG 15020	15000	15000	6	5	100 - 700	S + 273	24 DC	54	14.6

4 Actuation systems
Linear actuators

Magforce GTD

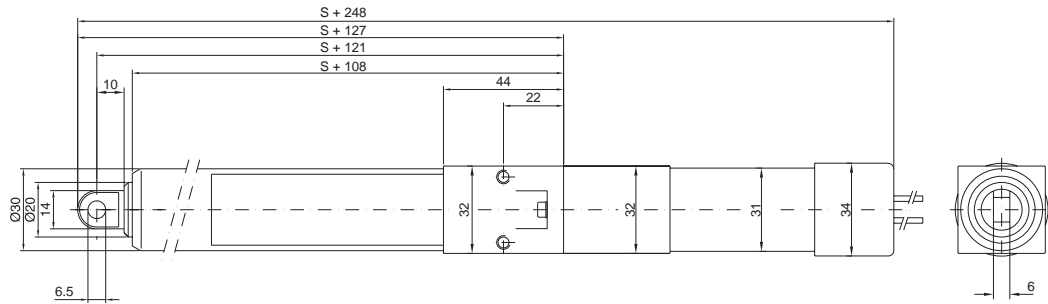

Legend:
S = stroke

Type	Force		Max. speed		Stroke (S)	Retr. Length (L)	Voltage	Protection	Weight
	push	pull	no load	full load					
	N		mm/s		mm	mm	V DC	IP	kg
GTD 0220	200	200	30	25	50 - 300	S + 99	24	00	0.9

Ordering key

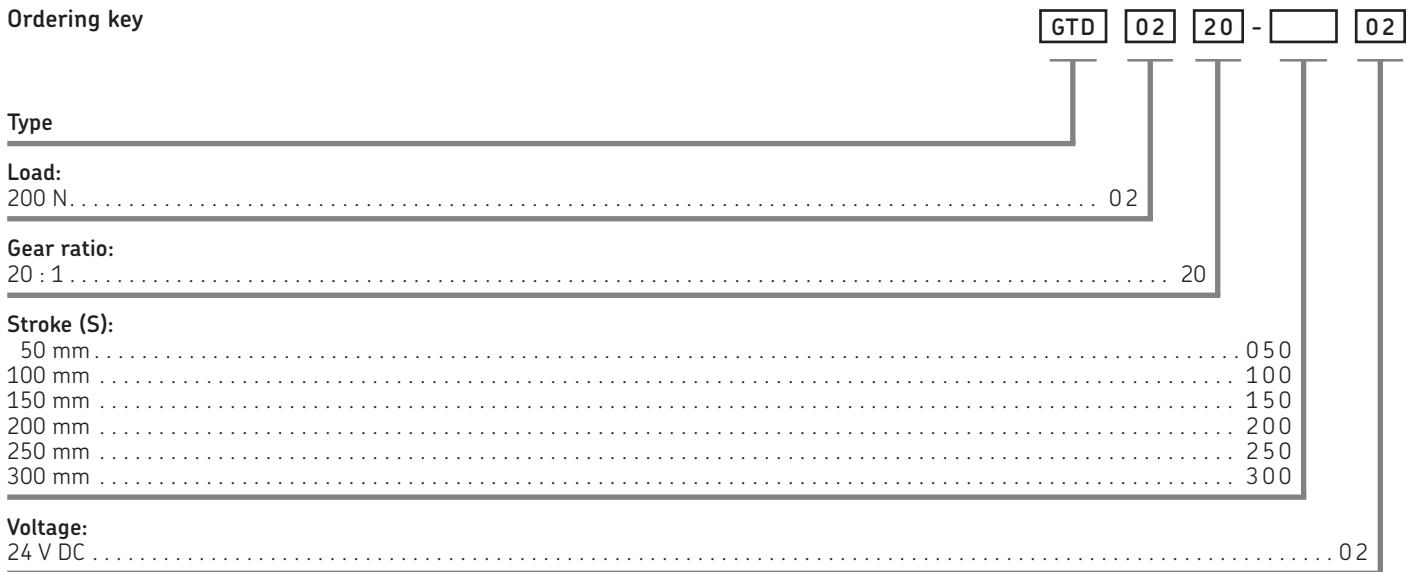

Example: **GTD 02 20 - [] 02**

Magforce WSP

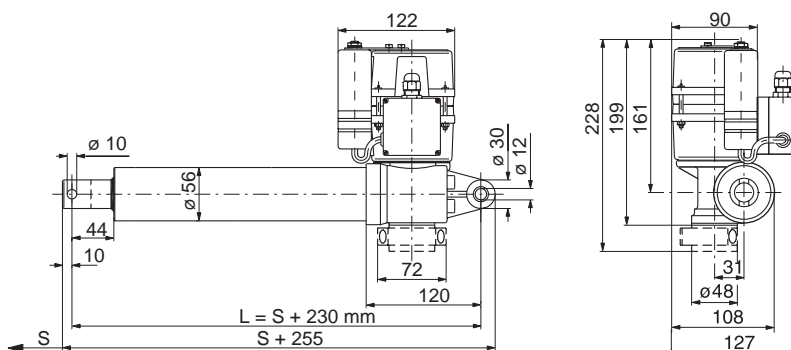

Legend:
S = stroke
L = retracted length

Type	Force		Max. speed		Stroke (S)	Retr. Length (L)	Voltage	Protection	Weight
	push	pull	no load	full load					
	N		mm/s		mm	mm	V AC	IP	kg
WSP 0510	500	500	68	57	100 - 700	S + 230	230	54	5.7
WSP 1030	1000	1000	23	19	100 - 700	S + 230	230	54	5.7
WSP 1550	1500	1500	13	11	100 - 700	S + 230	230	54	5.7
WSP 2650	2600	2600	7	5	100 - 700	S + 230	230	54	5.7

Ordering key

Type	WSP		-		-	
Load/Speed:						
500 N/57 mm/s.....				0510		
1000 N/19 mm/s.....				1030		
1500 N/11 mm/s.....				1550		
2600 N/ 5 mm/s.....				2650		
Stroke (S):						
100 mm.....						100
200 mm.....						200
300 mm.....						300
400 mm.....						400
500 mm.....						500
600 mm.....						600
700 mm.....						700
Customer options:						
Standard.....						01
Brake for self-locking on push.....						03
Extended shaft.....						16
Brake for self-locking on pull.....						24
Bronze nut/Low temperature grease/Extended shaft.....						81
Others (brake, limit switch, ext. motorshaft, incr. encoder, potentiometer, ...).....						XX

Example: **WSP 2650 - 400 - 81**

4 Actuation systems

Linear actuators

Magforce ASM

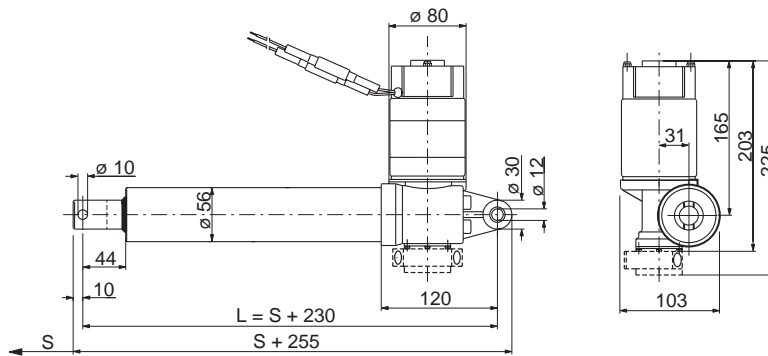

Legend:
S = stroke
L = retracted length

Type	Force		Max. speed		Stroke (S)	Retr. Length (L)	Voltage	Protection	Weight
	push	pull	no load	full load					
	N		mm/s		mm	mm	V DC	IP	kg
ASM 1010	1000	1000	58	48	100 - 700	S + 230	12/24	44	5.0
ASM 2030	2000	2000	22	18	100 - 700	S + 230	12/24	44	5.0
ASM 3030	3000	3000	10	8	100 - 700	S + 230	12/24	44	5.0
ASM 4050	4000	4000	6	5	100 - 700	S + 230	12/24	44	5.0

Ordering key

Type	ASM		-		-	
Load/Speed:						
1000 N/48 mm/s.....						1010
2000 N/18 mm/s.....						2030
3000 N/ 8 mm/s.....						3030
4000 N/ 5 mm/s.....						4050
Stroke (S):						
100 mm.....						100
200 mm.....						200
300 mm.....						300
400 mm.....						400
500 mm.....						500
600 mm.....						600
700 mm.....						700
Customer options:						
12 V DC						01
24 V DC						02
24 V DC, brake for self-locking on push						06
24 V DC, bronze nut, low temperature grease						07
24 V DC, brake for self-locking on push and pull						09
24 V DC, brake for self-locking on push and pull, low temperature grease						13
24 V DC, low temperature grease						14
24 V DC, extended shaft						16
Others (brake, limit switch, ext. motorshaft, incr. encoder, potentiometer, ...).....						XX

Example: **ASM** **3030** - **700** - **02**

Magforce DSP

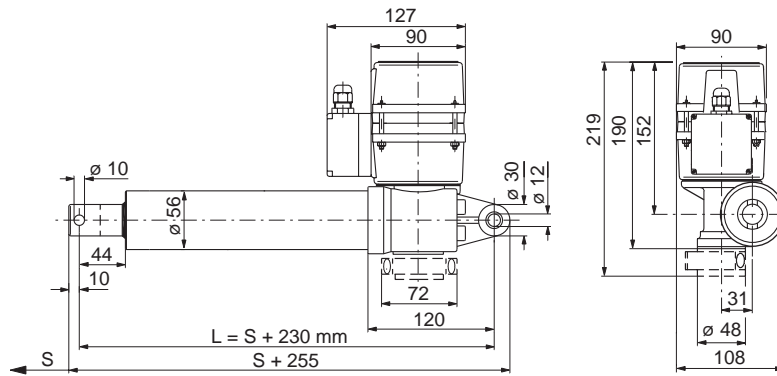

Legend:
 S = stroke
 L = retracted length

Type	Force		Max. speed		Stroke (S)	Retr. Length (L)	Voltage	Protection	Weight
	push	pull	no load	full load					
	N		mm/s		mm	mm	V AC	IP	kg
DSP 1010	1000	1000	62	52	100 - 700	S + 230	3 × 400	54	5.6
DSP 2530	2500	2500	20	17	100 - 700	S + 230	3 × 400	54	5.6
DSP 3250	3200	3200	12	10	100 - 700	S + 230	3 × 400	54	5.6
DSP 4550	4500	4500	6	5	100 - 700	S + 230	3 × 400	54	5.6

Ordering key

Type	DSP		-		-	
Load/Speed:						
1000 N/52 mm/s						1010
2500 N/17 mm/s						2530
3200 N/10 mm/s						3250
4500 N/ 5 mm/s						4550
Stroke (S):						
100 mm						100
200 mm						200
300 mm						300
400 mm						400
500 mm						500
600 mm						600
700 mm						700
Customer options:						
Standard						01
Brake for self-locking on push						03
Bronze nut, low temperature grease						08
Brake for self-locking on pull						10
Bronze nut, brake for self-locking on push						12
Brake for self-locking on push and pull						17
Low temperature grease						30
Extended shaft						122
Others (brake, limit switch, ext. motorshaft, incr. encoder, potentiometer, ...)						XX

Example: **DSP** **3250** - **700** - **122**

4 Actuation systems

Linear actuators

Magforce SKG

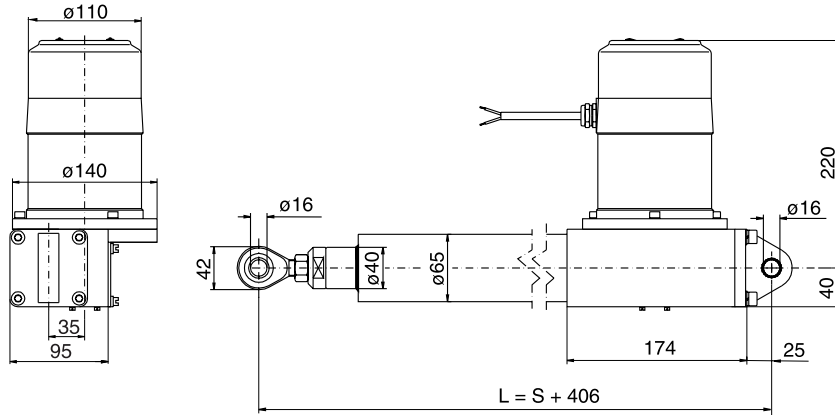

Legend:
 S = stroke
 L = retracted length

Type	Force		Max. speed		Stroke (S)	Retr. Length (L)	Voltage	Protection	Weight
	push	pull	no load	full load					
	N		mm/s		mm	mm	V DC	IP	kg
SKG 6005	6000	6000	66	55	100 - 700	S + 406	24	54	14.6
SKG 10010	10000	10000	36	30	100 - 700	S + 406	24	54	14.6
SKG 13020	13000	13000	18	15	100 - 700	S + 406	24	54	14.6
SKG 15040	15000	15000	10	8	100 - 700	S + 406	24	54	14.6

Ordering key

	SKG		-		-	01
Type						
Load/Speed:						
6000 N/55 mm/s.		06005				
10000 N/30 mm/s.		10010				
13000 N/15 mm/s.		13020				
15000 N/ 8 mm/s.		15040				
Stroke (S):						
100 mm.						100
200 mm.						200
300 mm.						300
400 mm.						400
500 mm.						500
600 mm.						600
700 mm.						700
Customer options:						
Standard.						01
Others (brake, limit switch, ext. motorshaft, incr. encoder, potentiometer, ...).						XX

Example: **SKG 06005 - 500 - 01**

Magforce SKD

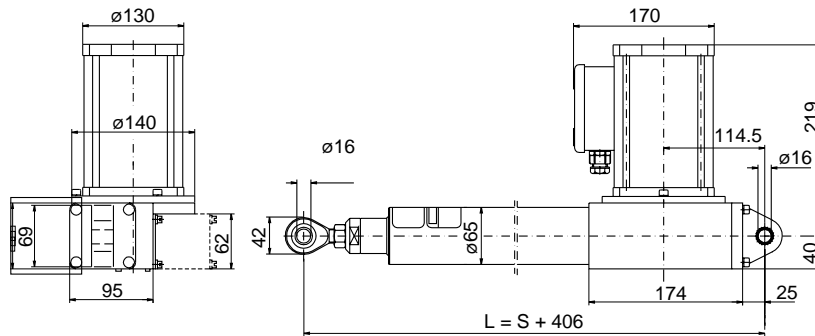

Legend:
 S = stroke
 L = retracted length

Type	Force		Max. speed		Stroke (S)	Retr. Length (L)	Voltage	Protection	Weight
	push	pull	no load	full load					
	N		mm/s		mm	mm	V AC	IP	kg
SKD 10007	10000	10000	30	25	100 - 700	S + 406	3 × 400	54	14.6
SKD 12010	12000	12000	25	21	100 - 700	S + 406	3 × 400	54	14.6
SKD 15020	15000	15000	13	11	100 - 700	S + 406	3 × 400	54	14.6
SKD 15040	15000	15000	6	5	100 - 700	S + 406	3 × 400	54	14.6

4

Ordering key



Type

Load/Speed:

10000 N/25 mm/s.....	10007
12000 N/21 mm/s.....	12010
15000 N/11 mm/s.....	15020
15000 N/ 5 mm/s.....	15040

Stroke (S):

100 mm.....	100
200 mm.....	200
300 mm.....	300
400 mm.....	400
500 mm.....	500
600 mm.....	600
700 mm.....	700

Customer options:

Standard.....	01
Others (brake, limit switch, ext. motorshaft, incr. encoder, potentiometer,).....	XX

Example: **SKD - 7010 - 500 - 01**

4 Actuation systems

Linear actuators

Magforce STW

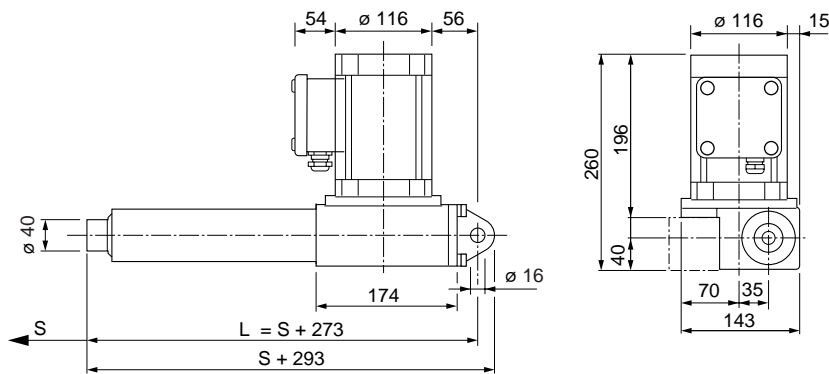

Legend:
S = stroke
L = retracted length

Type	Force		Max. speed		Stroke (S)	Retr. Length (L)	Voltage	Protection	Weight
	push	pull	no load	full load					
	N		mm/s		mm	mm	V AC	IP	kg
STW 5007	5000	5000	14	12	100 - 700	S + 273	230	54	14.6
STW 7010	7000	7000	10	8	100 - 700	S + 273	230	54	14.6
STW 10020	10000	10000	5	4	100 - 700	S + 273	230	54	14.6
STW 15040	15000	15000	2	2	100 - 700	S + 273	230	54	14.6

Ordering key

Type	STW		-		-	
Load/Speed:						
5000 N/ 12 mm/s.					05007	
7000 N/ 8 mm/s.					07010	
10000 N/ 4 mm/s.					10020	
15000 N/ 2 mm/s.					15040	
Stroke (S):						
100 mm.						100
200 mm.						200
300 mm.						300
400 mm.						400
500 mm.						500
600 mm.						600
700 mm.						700
Customer options:						
Standard.						01
Limit switch.						05
Low temperature grease.						08
Others (brake, limit switch, ext. motorshaft, incr. encoder, potentiometer, ...).						XX

Example: **STW** - **7010** - **500** - **01**

Magforce STG

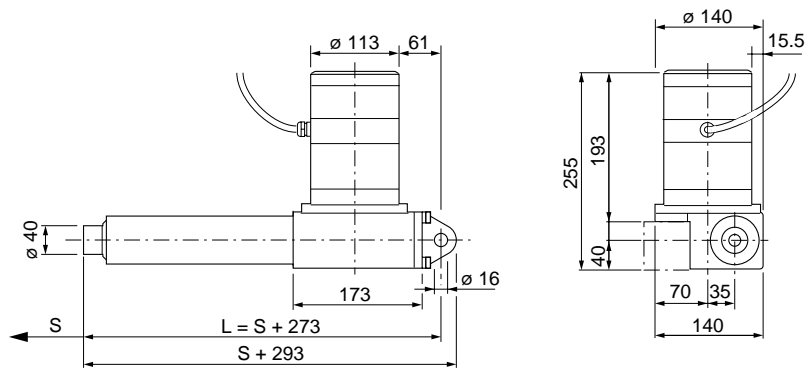

Legend:
 S = stroke
 L = retracted length

Type	Force		Max. speed		Stroke (S)	Retr. Length (L)	Voltage	Protection	Weight
	push	pull	no load	full load					
	N		mm/s		mm	mm	V DC	IP	kg
STG 10007	10000	10000	17	14	100 - 700	S + 273	24	54	14.6
STG 12010	12000	12000	13	11	100 - 700	S + 273	24	54	14.6
STG 15020	15000	15000	6	5	100 - 700	S + 273	24	54	14.6
STG 15040	15000	15000	4	3	100 - 700	S + 273	24	54	14.6



Ordering key



Type

Load/Speed:

10000 N/14 mm/s.....	10007
12000 N/11 mm/s.....	12010
15000 N/ 5 mm/s.....	15020
15000 N/ 3 mm/s.....	15040

Stroke (S):

100 mm.....	100
200 mm.....	200
300 mm.....	300
400 mm.....	400
500 mm.....	500
600 mm.....	600
700 mm.....	700

Customer options:

Standard	01
Others (brake, limit switch, ext. motorshaft, incr. encoder, potentiometer,).....	XX

Example: **STG** **15020** - **600** - **01**

4 Actuation systems

Linear actuators

Magforce STD

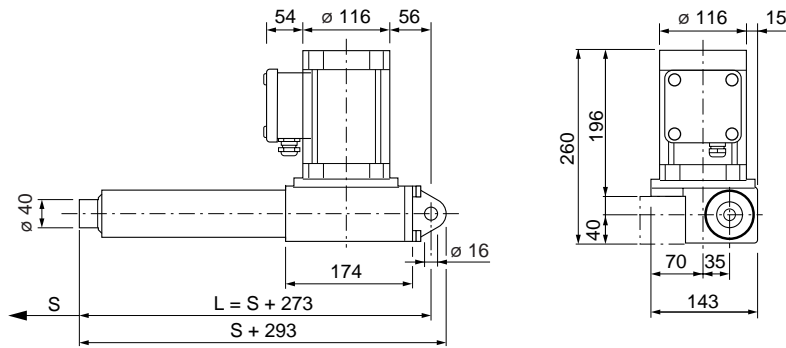

Legend:
S = stroke
L = retracted length

Type	Force		Max. speed		Stroke (S)	Retr. Length (L)	Voltage	Protection	Weight
	push	pull	no load	full load					
	N		mm/s		mm	mm	V AC	IP	kg
STD 10007	10000	10000	12	10	100 - 700	S + 273	3×400	54	16.3
STD 12010	12000	12000	9	8	100 - 700	S + 273	3×400	54	16.3
STD 15020	15000	15000	5	4	100 - 700	S + 273	3×400	54	16.3
STD 15040	15000	15000	3	2	100 - 700	S + 273	3×400	54	16.3

Ordering key

Type

Load/Speed:

10000 N/ 10 mm/s.	10007
12000 N/ 8 mm/s.	12010
15000 N/ 4 mm/s.	15020
15000 N/ 2 mm/s.	15040

Stroke (S):

100 mm.	100
200 mm.	200
300 mm.	300
400 mm.	400
500 mm.	500
600 mm.	600
700 mm.	700

Customer options:

Standard.	01
Extended shaft.	11
Safety nut on push.	13
Low temperature grease.	19
Safety nut on push and pull.	34
Others (brake, limit switch, ext. motorshaft, incr. encoder, potentiometer, ...).	XX

STD - - -

Example: **STD** **15020** - **700** - **01**

Magforce SKS/SKA

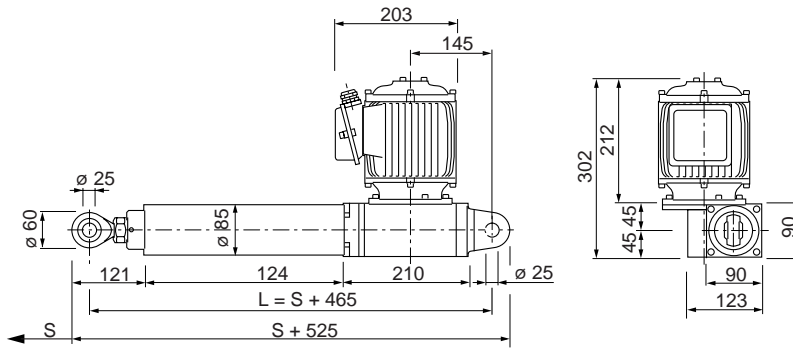

Legend:
S = stroke
L = retracted length

Type	Force		Max. speed		Stroke (S)	Retr. Length (L)	Voltage	Protection	Weight
	push	pull	no load	full load					
	N		mm/s		mm	mm	V AC	IP	kg
SKS/SKA 15404	15000	15000	54	45	100 - 700	S + 465	3 × 400	54	30.0
SKS/SKA 20406	20000	20000	41	34	100 - 700	S + 465	3 × 400	54	30.0
SKS/SKA 25412	25000	25000	20	17	100 - 700	S + 465	3 × 400	54	30.0
SKS/SKA 30423	30000	30000	11	10	100 - 700	S + 465	3 × 400	54	30.0

Ordering key

	SK		-		-	01
Type						
Option:						
No option	S					
With limit switches	A					
Load/Speed:						
15000 N / 45 mm/s						15404
20000 N / 34 mm/s						20406
25000 N / 17 mm/s						25412
30000 N / 10 mm/s						30423
Stroke (S):						
100 mm						100
200 mm						200
300 mm						300
400 mm						400
500 mm						500
600 mm						600
700 mm						700
Customer options:						
Standard						01
Others (ext. motorshaft, incr. encoder, potentiometer, ...)						XX

Example: SK S 25412 - 400 - 01

4 Actuation systems
Linear actuators

Magforce SLS

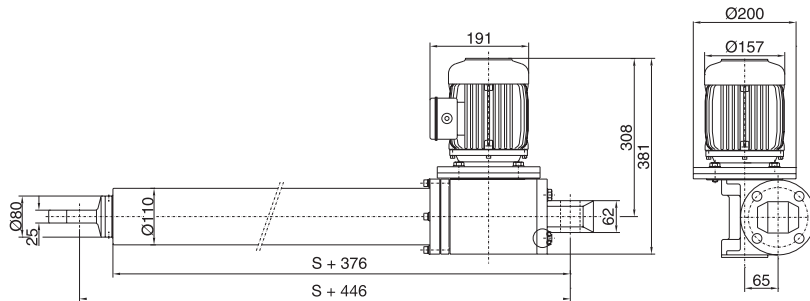

Legend:
S = stroke

Type	Force		Max. speed		Stroke (S)	Retr. Length (L)	Voltage	Protection	Weight
	push	pull	no load	full load					
	N		mm/s		mm	mm	V AC	IP	kg
SLS 18006	18000	18000	88	74	100 - 700	S + 446	3×400	54	40.0
SLS 34013	34000	34000	43	36	100 - 700	S + 446	3×400	54	40.0
SLS 50020	50000	50000	27	23	100 - 700	S + 446	3×400	54	40.0
SLS 50028	50000	50000	19	16	100 - 700	S + 446	3×400	54	40.0
SLS 50050	50000	50000	10	9	100 - 700	S + 446	3×400	54	40.0

Ordering key

	SLS				
Type					
Load:					
18000 N				180	
34000 N				340	
50000 N				500	
Gear ratio:					
6 : 1				06	
13 : 1				13	
20 : 1				20	
36 : 1				36	
50 : 1				50	
Stroke (S):					
100 mm					100
200 mm					200
300 mm					300
400 mm					400
500 mm					500
600 mm					600
700 mm					700
Voltage:					
Standard					01
Others (ext. motorshaft, incr. encoder, potentiometer, ...)					XX

Example: **SLA**



4 Actuation systems

Linear actuators

ECOMAG

The ECOMAG (→ **figure 13**) is a compact and cost effective actuator which is designed for medical and home environment. It allows precise movements and ergonomically correct positioning. The safety and reliability of the ECOMAG is well proven.

Benefits:

- Compact
- Cost effective
- Control unit can be mounted to the actuator

Figure 13

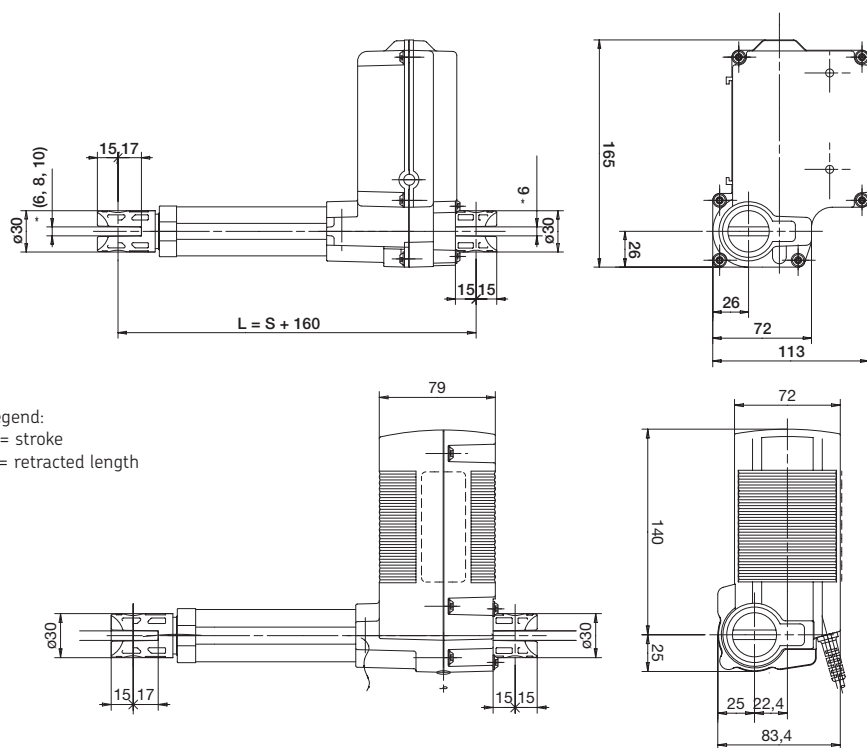
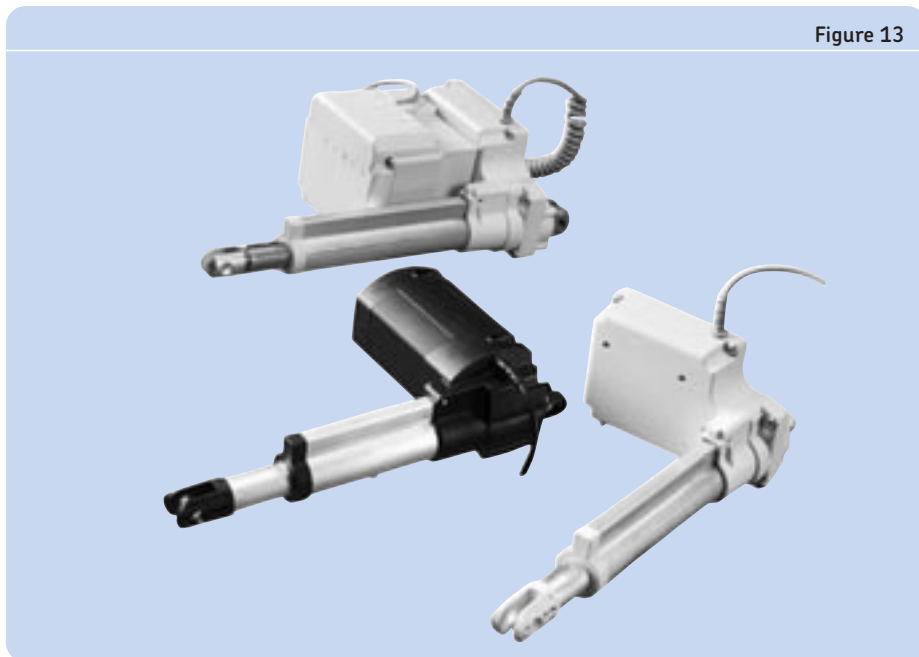

Type	Force		Max. speed		Stroke (S)	Retr. Length (L)	Voltage	Protection	Weight
	push	pull	no load	full load					
	N		mm/s		mm	mm	V DC	IP	kg
ECO 20/40	2000	0	13	9	50 - 300	S+160	24	X4	2.1
ECO 60/80	6000	0	7	4	50 - 300	S+160	24	X4	2.1
ECO 30/50	2000	2000	13	9	50 - 300	S+160	24	X4	2.5
ECO 70/90	6000	4000	7	4	50 - 300	S+160	24	X4	2.5

Ordering key

ECO - 0 M M - 000

Type

Load/Housing:

Push	Pull	Housing	
2000 N	0	Large	2
2000 N	2000 N	Large	3
2000 N	0	Small	4
2000 N	2000 N	Small	5
6000 N	0	Large	6
6000 N	4000 N	Large	7
6000 N	0	Small	8
6000 N	4000 N	Small	9

Encoder:

Without (cable coiled with 2-pin Minifit plug/or client option)	0
With (cable coiled with 8-pin DIN plug/or client option)	9

Current cut-off:

Without	0
---------	---

Stroke (S):

50 mm	05
100 mm	10
150 mm	15
200 mm	20
250 mm	25
300 mm	30

Fork Head (groove depth 17 mm):

Hole, Ø 12 mm, groove width 10 mm	M
-----------------------------------	---

Hinge (groove depth 15 mm):

Hole, Ø 12 mm, groove width 10 mm	M
-----------------------------------	---

Hinge position:

0°	1
22.5°	2
45°	3
77,5°	4
90°	5

Colour:

Black	A
Grey RAL 7035	B

Options:

No options	0
Back-up nut (available only for drives with 6kN, obligatory for UL 2601) - only for ECO7/9, L = +23 mm	A
FOR ECO3,-/ ECO5.- ONLY (no back up nut)	
Quick-release, motor direction push, fork head bore parallel to lever, L = +40 mm	B
Quick-release, motor direction push, fork head bore 90° to lever, L = +40 mm	C
Quick-release, motor direction pull, fork head bore parallel to lever, L = +40 mm	F
Quick-release, motor direction pull, fork head bore 90° to lever, L = +40 mm	G
Mechanical anti-pinching protection pull, motor direction push, L = +13 mm	K
Mechanical anti-pinching protection push, motor direction pull, L = +13 mm	L

Example: ECO 5 0 - 0 15 M M 3 A K - 000



4 Actuation systems

Linear actuators

CALA 36

CALA 36 (→ **figure 14**) is a compact 12 or 24 V DC actuator, intended for industrial use.

The motor and drive spindle are connected in-line through a planetary gear assembly. This makes the compact design suitable in applications where space is restricted. A comprehensive range of suitable SKF control systems is available.

Benefits:

- In-line layout
- Aesthetic design
- High operating reliability

Figure 14

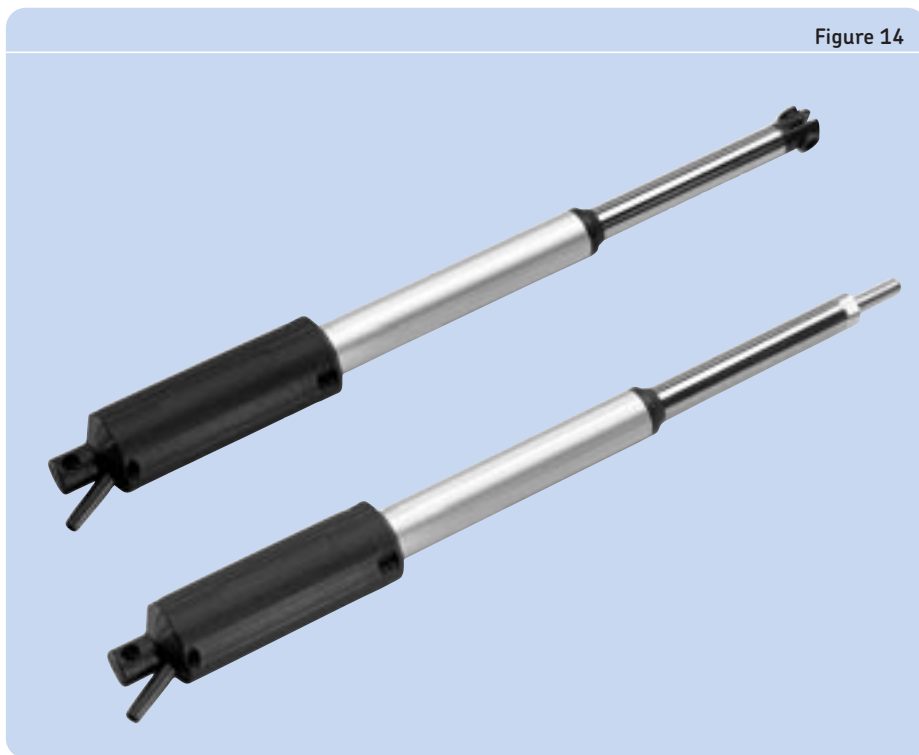

Type	Force		Max. speed		Stroke (S)	Retr. Length* (L)	Voltage	Protection	Weight
	push	pull	no load	full load					
	N		mm/s		mm	mm	V DC	IP	kg
CALA 36A	600	600	23	12	50 - 200	S + 215/226/257	12/24	44	0.9 - 1.4

* Dimension depends on selected front attachment

CALA 36A

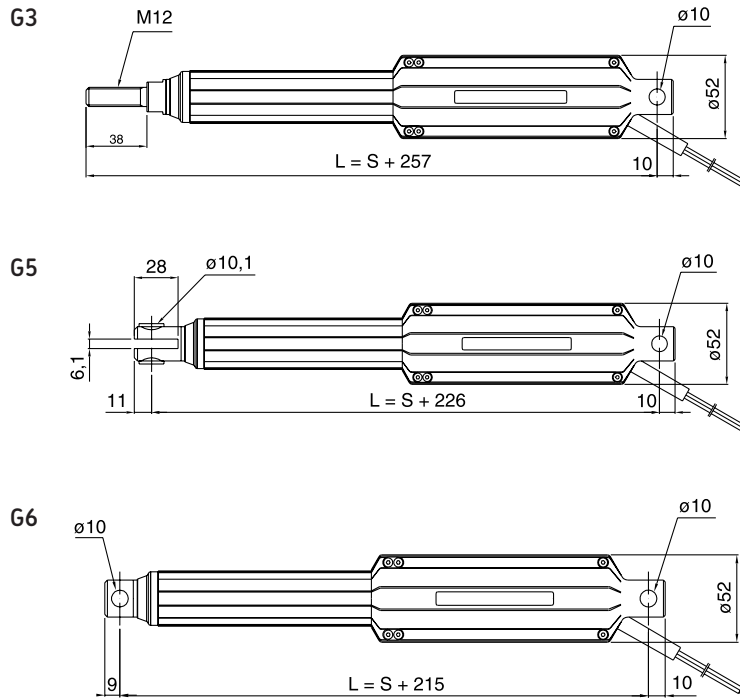

Legend:
S = stroke
L = retracted length

Ordering key



Type

Load/Speed:

600 N/23 - 12 mm/s..... A

Stroke (S):

50 mm	050
100 mm	100
150 mm	150
200 mm	200
50 mm < S < 200 mm	- - -

Front attachment:

Male thread, M12.....	G3
Fork end, Ø 10.1 mm.....	G5
Hole, Ø 10.0 mm	G6

Motor voltage:

12 V DC.....	D12
24 V DC.....	D24

Cable:

Straight 0.25 m, no plug	U
Straight 1.9 m, jack plug	T2
Straight 1.9 m, no plug	T2P

Example: CALA 36 A x 150 x 4 G5 / D12 T2P



4 Actuation systems

Linear actuators

MATRIX

The MATRIX series (→ **figure 15**) includes powerful AC and DC-actuators. They run very quietly, take up little space and can be installed at virtually every angle in vertical or horizontal position. The MATRIX range is complemented by the KOM control units, which allow a flexible and application focused control system.

Benefits:

- Long service life
- Silent operation
- Full system with control, operating units and accessories
- Synchronization possible
- Compact and aesthetic
- Safety nut in standard

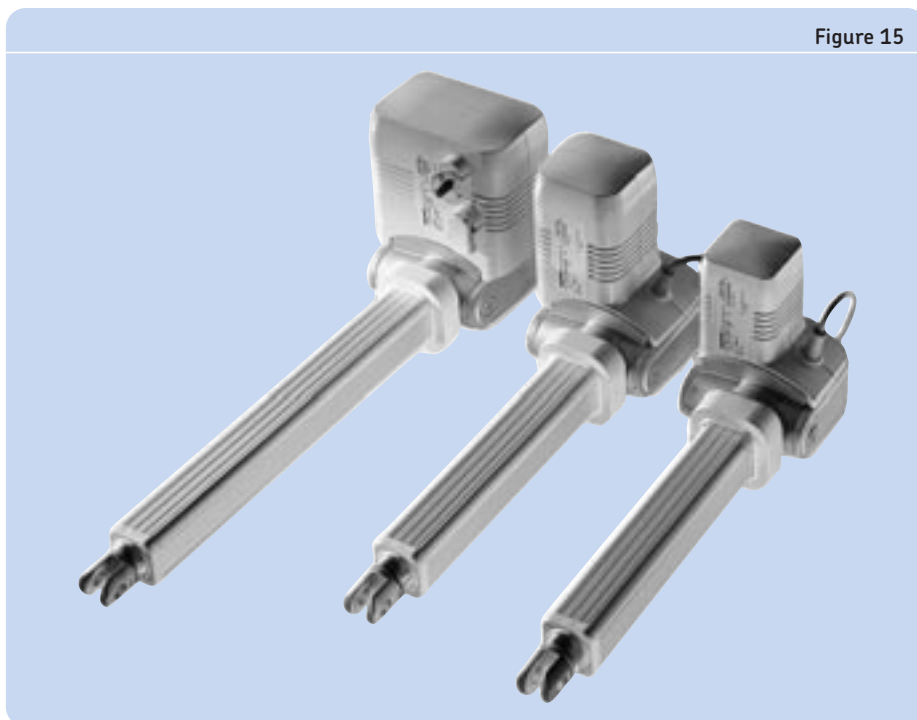

Figure 15

Type	Force		Max. speed		Stroke (S)	Retr. Length (L)	Voltage	Protection	Weight
	push	pull	no load	full load					
	N		mm/s		mm	mm	V	IP	kg
MAX6.-C	3000	3000	18	15	50 - 700	S + 215**	120/230 AC	66	4.2
MAX6.-B	4000	4000	10	8	50 - 700	S + 215**	120/230 AC	66	4.5
MAX6.-A	8000	6000	8	6	50 - 700	S + 215**	120/230 AC	66	4.8
MAX1.-C	1500	1500	18	13	50 - 700	S + 195*	24 DC	66	3.6
MAX1.-B	2000	2000	9	6	50 - 700	S + 195*	24 DC	66	3.7
MAX3.-C	3000	3000	18	13	50 - 700	S + 215**	24/12 DC	66	4.0
MAX1.-A	4000	4000	7	5	50 - 700	S + 195*	24 DC	66	4.0
MAX3.-B	4000	4000	9	6	50 - 700	S + 215**	24/12 DC	66	4.2
MAX3.-A	8000	6000	7	5	50 - 700	S + 215**	24/12 DC	66	4.5

* stroke < 350 mm retr. Length stroke + 260 mm
 ** stroke > 350 mm retr. Length stroke + 280 mm

Accessories

Mains cable	Plug	Country	Order number	Comment
Straight cable 3.5	Schuko	DE	140306	
Straight cable 3.5	SEV	CH	140316	
Straight cable 3.5	UL	USA	140355	
Straight cable 3.5	Hospital grade	USA	140360	
Straight cable 3.5	British standard	UK	140350	
Coiled cable 1.2 m/2.2 m	Schuko	DE	140342	
Coiled cable 1.2 m/2.2 m	SEV	CH	140378	
Straight cable 3.5	SEV	CH	140422-3500	Polyurethane cable
Straight cable 3.5	Schuko	DE	140426-3500	Polyurethane cable
Strain relief for mains cable			ZBE-952253	
Tool for plugs (Jack/D-Sub/Mains)			140375	
Operating device adaptor (D-Sub 9-pole)			140420	

4 Actuation systems

Linear actuators

CARE 33

Efficient design provides the CARE 33 actuators (→ **figure 16**) with a high dynamic load capacity, silent operation and low current consumption.

The safety features of the design make it particularly suitable for solving a large number of positioning needs in equipment for ergonomic and/or industrial applications.

The gearbox floats so that the load path passes directly through a support bearing located in the rear attachment. This design offers a long operational life and minimised the transmitted noise level.

Benefits:

- Silent operation
- Multiple speed/load variants
- Easy to adjust limit switches
- Different attachment options

Figure 16

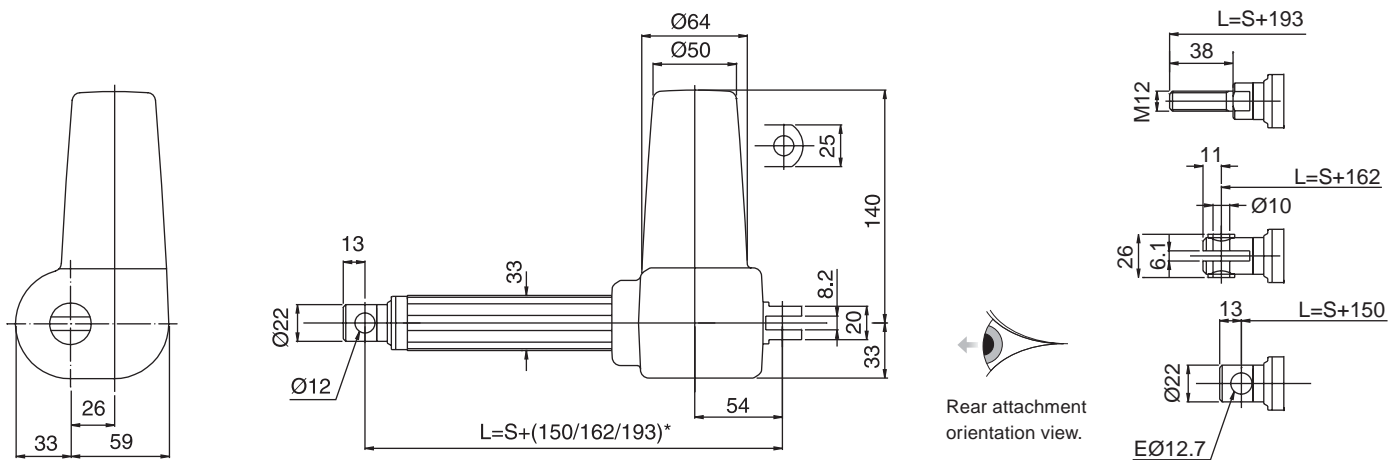

Legend:
S = stroke
L = retracted length

Type	Force		Max. speed		Stroke (S)	Retr. Length* (L)	Voltage	Protection	Weight
	push	pull	no load	full load					
	N		mm/s		mm	mm	V DC	IP	kg
CARE 33H	800	800	45	32	50 - 500	S + 150/162/193	12/24	44/65	1.5 - 2.4
CARE 33M	1400	1400	22	16	50 - 500	S + 150/162/193	12/24	44/65	1.5 - 2.4
CARE 33A	2000	2000	12	8	50 - 300	S + 150/162/193	12/24	44/65	1.5 - 2.0

* Dimension depends on selected front attachment

Ordering key

CARE	33																			
------	----	--	--	--	--	--	--	--	--	--	--	--	--	--	--	--	--	--	--	--

Type

Load (N)/Speed (mm/s):

2000/12 - 8	A
1400/22 - 16	M
800/45 - 32	H

Stroke:

50 mm	0 5 0
100 mm	1 0 0
150 mm	1 5 0
200 mm	2 0 0
300 mm	3 0 0
400 mm (not possible for CARE 33A)	4 0 0
500 mm (not possible for CARE 33A)	5 0 0
50 < S < 500 mm (S > 500 mm contact SKF)	- - -

Front attachment:

Hole, Ø = 12.0 mm	1
Hole, Ø = 12.7 mm	2
Hole, Ø = 10.0 mm, slot 6.1 mm (retracted length, L = S + 162 mm)	3
Male thread M12 (retracted length, L = S + 193 mm)	4

Rear attachment:

Hole, Ø = 12.0 mm	1
Hole, Ø = 12.7 mm	2
Hole, Ø = 8.0 mm	3
Hole, Ø = 10.0 mm	4

Protection class:

IP65	1
IP44	2

Feed back:

No option	0
Encoder (2-channel)	1

Cable/Connection plug:

Straight, 2.0 m, no connector	1
Coiled, 2.0 m, jack plug	2
Straight, 2.0 m, DIN 8U-plug (for 2-channel encoder)	3
Straight, 2.0 m, jack plug	5

Orientation of rear attachment:

0°	0 0 0
15° clockwise	0 1 5
30° clockwise	0 3 0
45° clockwise	0 4 5
60° clockwise	0 6 0
75° clockwise	0 7 5
90° clockwise	0 9 0
105° clockwise	1 0 5
120° clockwise	1 2 0
135° clockwise	1 3 5
150° clockwise	1 5 0
165° clockwise	1 6 5

Motor voltage:

24 V DC	2 4
12 V DC	1 2

Self locking feature (mandatory when selecting load/speed version "H" or "M"):

No self locking required	0
Self locking for pulling load	1
Self locking for pushing load	2

Example: CARE 33 M 300 2 2 1 0 5 1 3 5 2 4 1



4 Actuation systems

Linear actuators

RUNNER

The RUNNER (→ **figure 17**) is a very compact, high performance actuator combining maximum load and maximum speed. The system includes a single fault safe control unit for up to 3 actuators as well as corresponding accessories. The RUNNER system is compatible with the TELEMAG DC series.

Benefits:

- High offset load
- High push/pull force
- Compact design
- Silent operation
- Long service life
- Safety nut in standard
- High security factor in static

Figure 17

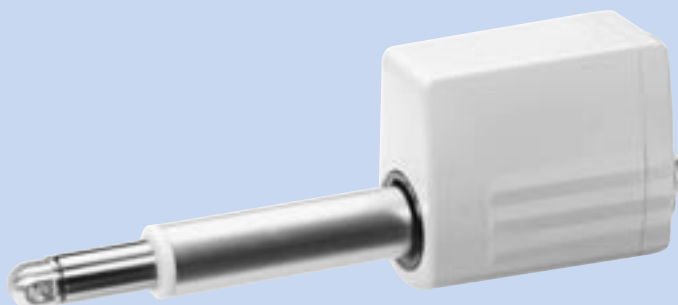

Type	Force		Max. speed		Stroke (S)	Retr. Length (L)	Voltage	Protection**	Weight
	push	pull	no load	full load					
	N		mm/s		mm	mm	V DC	IP	kg
R20	8000	8000	10	7	100 - 700	S + 215 / 315*	24	X4 / X6	4.7
R21	10000	8000	8	5	100 - 700	S + 215 / 315*	24	X4 / X6	4.7
R22	12000	8000	7	4	100 - 700	S + 215 / 315*	24	X4 / X6	4.7

* If stroke > or = to 500 mm: L = S + 315 mm
 ** Protection class in static, for outside applications, please contact SKF

RU20/RU21/RU22

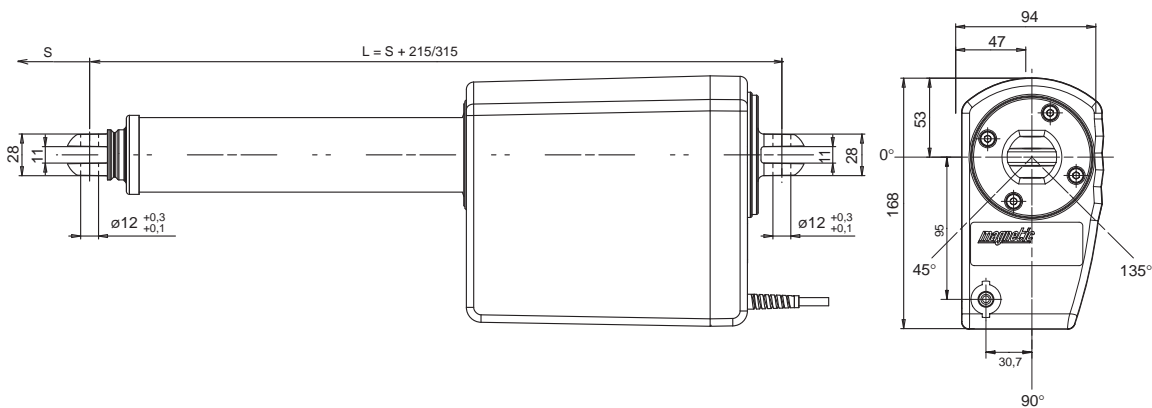

Legend:
 S = stroke
 L = retracted length

Ordering key

Type

Voltage:

24 V DC 2

Load (N)/Speed (mm/s):

12000/8000 N/4-7 mm/s 2
 10000/8000 N/5-8 mm/s 1
 8000/8000 N/7-10 mm/s 0

Stroke (S)/Retracted length (L):

50 mm/315 mm 0 5 0 3 1 5
 100 mm/315 mm 1 0 0 3 1 5
 150 mm/365 mm 1 5 0 3 6 5
 200 mm/415 mm 2 0 0 4 1 5
 250 mm/465 mm 2 5 0 4 6 5
 300 mm/515 mm 3 0 0 5 1 5
 350 mm/565 mm 3 5 0 5 6 5
 400 mm/615 mm 4 0 0 6 1 5
 450 mm/665 mm 4 5 0 6 6 5
 500 mm/815 mm 5 0 0 8 1 5
 550 mm/865 mm 5 5 0 8 6 5
 600 mm/915 mm 6 0 0 9 1 5
 650 mm/965 mm 6 5 0 9 6 5
 700 mm/1015 mm 7 0 0 X X X

Protection class/Colour:

IPX4, grey RAL 7035 A
 IPX6, grey RAL 7035 B

Cable:

Straight cable, 1.5 m, DIN-8 plug 1 5

Rear attachment - orientation/hole diameter:

0°, Ø12.0 mm 0

Options 1:

No option 0

Options 2:

No option 0

Customization:

No option 0 0

RU 2 - 15 0 0 0 - 00

4

Example: RU 2 1 - 4 5 0 6 6 5 B 1 5 0 0 0 - 00

Ordering key

Dynamic load (N)/ Speed (mm/s)		Motor* options	
3000/20-13	7000/10-5	24 V DC, high speed	A
3000/14-9	7000/7-4	24 V DC	B
H	L	* Overload protection is standard	

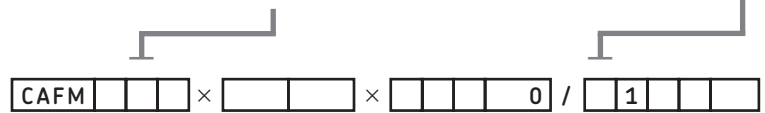

Type

Actuator connections:

Master control only	1
One (1) additional actuator	2
Two (2) additional actuators	3

Tube:

Plastic, fixed	1
Plastic, free with tube end stop (anti-jamming)	2
Steel, fixed	3
Steel, free without tube end stop (anti-jamming)	4

Stroke (S)/ Retracted length (L):

50 - 100 mm / 290 mm	- - 2 9 0
101 - 150 mm / 340 mm	- - 3 4 0
151 - 200 mm / 410 mm	- - 4 1 0
201 - 250 mm / 510 mm (not available with plastic push tube)	- - 5 1 0

Rear attachment length:

Hole Ø 10 mm, plastic	A
Hole Ø 12 mm, plastic	B
Hole Ø 12 mm, aluminium	D
Hole Ø 10 mm, plastic natural, high load	E
Hole Ø 12 mm, plastic natural, high load	F

Orientation of rear attachment:

0°	0
90°	9

Tube attachment:

Hole Ø 10 mm (only for steel tube)	A
Hole Ø 12 mm (only for steel tube)	B
U-fork end with hole Ø 10 mm, (standard for plastic tube)	C
U-fork end with hole Ø 12 mm, (standard for plastic tube)	D
Hole Ø 12 mm, with bushing 12 - 14 (only for steel tube)	E
Hole Ø 10 mm, with bushing 10 - 12 (only for steel tube)	F

Back-up nut:

No	0
Yes	1

Colour:

Black	B
Grey	G

Quick release:

No	0
----	---

Transformer & mains cable (PVC cable, class II):

230 VAC, coiled cable, 3.0 m, grey, EU-plug	A
230 VAC, straight cable, 3.2 m, black, EU-plug	B
230 VAC, straight/coiled cable 3.0 m (1 m + 2 m), grey, EU-plug	G
120 VAC, straight cable, 3.0 m, grey, US-plug	H
240 VAC, straight cable, 3.0 m, grey, UK-plug	I

Battery:

No battery	0
Battery connection	2

Protection class:

IP51	51
IPX4	X4
IP66	66

Example: **CAFM 2 H 3** × **100 290** × **E 0 F 0 B 0** / **B 1 B 2 X 4**

4 Actuation systems

Linear actuators

CAFS

The efficient design of the CAF actuator (→ **figure 19**) enables a high dynamic load capacity in combination with a low current consumption and noise level. The standard design includes built-in limit switches and flexible orientation of attachments.

Design options are available to optimize application safety. The most common of these is the metal back-up nut (mechanical failure), nonfixed extension tube (prevents crush injuries).

Benefits:

- Economical design solutions
- High load capacity
- Maintenance-free
- Integration and approval made easy

Figure 19

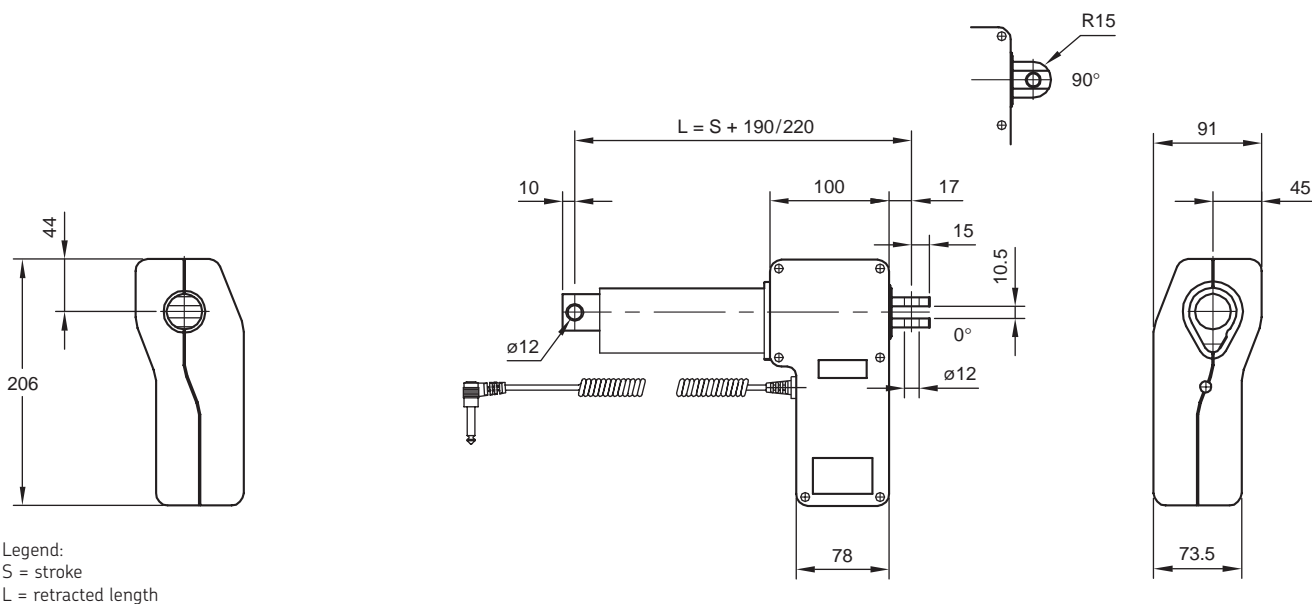
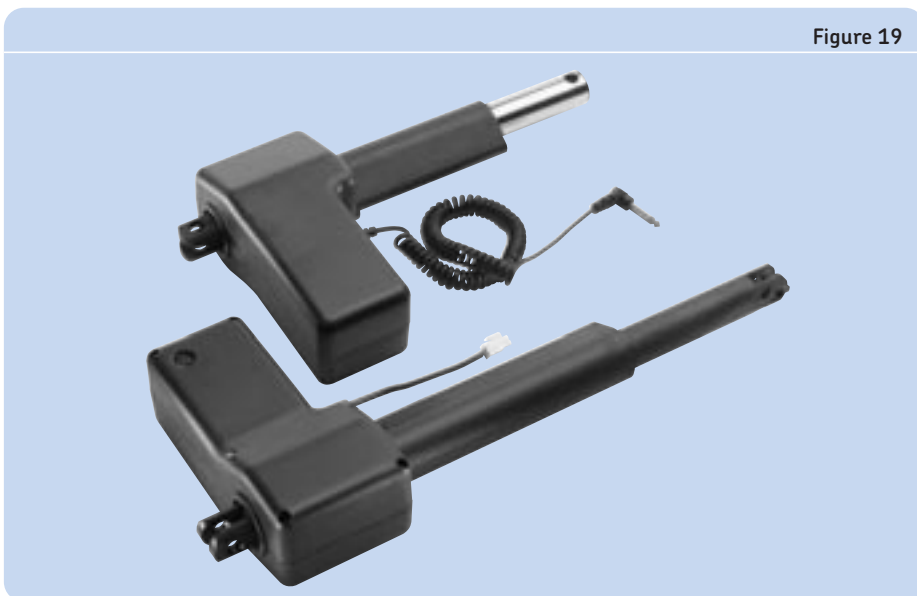

Type	Force		Max. speed		Stroke (S)	Retr. Length (L)	Voltage	Protection	Weight
	push	pull	no load	full load					
	N		mm/s		mm	mm	V DC	IP	kg
CAFS-H - motor A	3000	3000	20	12	50 - 300	S + 190/220	12/24	51/X4/66	3.5
CAFS-H - motor B	3000	3000	14	9	50 - 300	S + 190/220	12/24	51/X4/66	3.5
CAFS-L - motor A	7000*	3000	10	5	50 - 300	S + 190/220	12/24	51/X4/66	3.5
CAFS-L - motor B	7000*	3000	7	4	50 - 300	S + 190/220	12/24	51/X4/66	3.5

* Push force for strokes > 250 mm: 5000 N

4 Actuation systems

Linear actuators

MAGPUSH

MAGPUSH linear actuators (→ figure 20) are extremely quiet and smooth running. They take up little space, are maintenance-free and can be installed vertically or horizontally or at an intermediate angle.

The MAGPUSH actuators are very robust and work in many applications. They are ideally suited for raising and lowering large loads.

Benefits:

- Long stroke by a short assembly dimension
- Long service life
- Silent operation
- Robust

Figure 20



Type	Force		Max. speed		Stroke (S)	Retr. Length (L)	Voltage	Protection	Weight
	push	pull	no load	full load					
	N		mm/s		mm	mm	V AC	IP	kg
GC 84 UB	400	400	8	8	210	S+170	230	55	3.0
LC 6.6 UB	3000	3000	15	15	310	-	230	55	11.0
LC 12.6 UB	6000	6000	30	30	310	-	230	55	11.0
GC 84 TL	500	300	6	6	200/300/500	54	230	54	2.4
HC 85 UB	1500	1500	10	10	260	S+190	230	55	6.0

MAGPUSH GC 84 UB

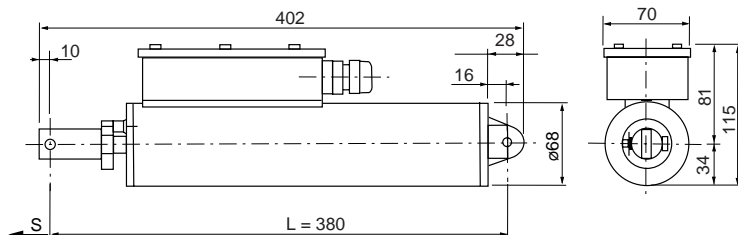

Legend:
S = stroke
L = retracted length

Type	Force		Max. speed		Stroke (S)	Retr. Length (L)	Voltage	Protection	Weight
	push	pull	no load	full load					
	N		mm/s		mm	mm	V AC	IP	kg
GC 84 UB	400	400	8	8	210	380	230	55	3.0

Ordering key

GC84UB - 01

Type

Load / Speed / Stroke (S):

400 N (push) / 8 mm/s / 210 mm 01

Example: GC84UB - 01

MAGPUSH LC .. UB

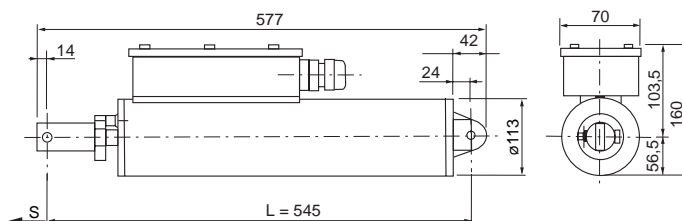

Legend:
S = stroke
L = retracted length

Type	Force		Max. speed		Stroke (S)	Retr. Length (L)	Voltage	Protection	Weight
	push	pull	no load	full load					
	N		mm/s		mm	mm	V AC	IP	kg
LC 6.6 UB	3000	3000	15	15	310	545	230	55	11.0
LC 12.6 UB	6000	6000	30	30	310	545	230	55	11.0

Ordering key

LC . UB - 01

Type:

LC6.6UB for 3000 N (push) / 15 mm/s / 310 mm 6.6
LC12.6UB for 6000 N (push) / 30 mm/s / 310 mm 12.6

Example: LC6.6UB - 01

4 Actuation systems

Linear actuators

MAGPUSH GC 84 TL

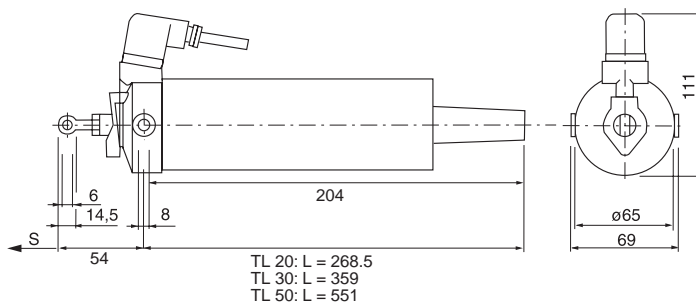

Legend:

S = stroke

L = retracted length

Type	Force		Max. speed		Stroke (S)	Retr. Length (L)	Voltage	Protection	Weight
	push	pull	no load	full load					
	N		mm/s		mm	mm	V AC	IP	kg
GC 84 TL	500	300	6	6	200/300/500	54	230	54	2.3 - 2.4

Ordering key

GC84TL - [] []

Type

Load / Speed / Stroke (S):

500 N (push) 300 N (pull) / 6 mm/s / 200 mm	20
500 N (push) 300 N (pull) / 6 mm/s / 300 mm	30
500 N (push) 300 N (pull) / 6 mm/s / 500 mm	50

Option:

No option	01
With integrated relays	02

Example: GC84TL - 20 01

Accessories for MAGPUSH GC 84 TL

Accessories	Order N°
Fixing bracket	940303
Pivot screws, alone	940306
Pull adapter	939185
Rear hinge, short	940646
Rear hinge, long	940611

MAGPUSH HC 85 UB

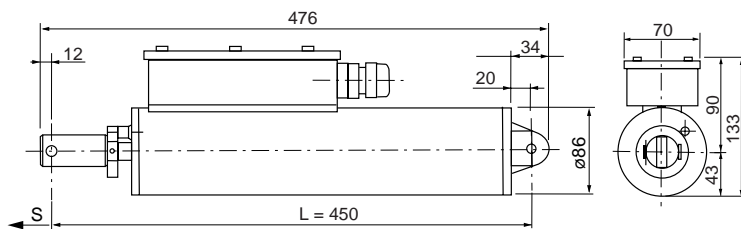

Legend:
 S = stroke
 L = retracted length

Type	Force		Max. speed		Stroke (S)	Retr. Length (L)	Voltage	Protection	Weight
	push	pull	no load	full load					
	N		mm/s		mm	mm	V AC	IP	kg
HC 85 UB	1500	1500	10	10	260	450	230	55	6.0



Ordering key

HC85UB - **01**

Type

Option:

No option -

Potentiometer 1000 Ohm. 3

Load / Speed / Stroke (S):

1500 N / 10 mm/s / 260 mm. 01

Example: **HC85UB** - **3 01**

4 Actuation systems

Linear actuators

MAGTOP CS

The MAGTOP product family (→ **figure 21**) is a compact and cost-effective actuator, primarily designed for the building and construction segment.

The MAGTOP is suitable for the opening and closing of windows, doors, smoke vents, etc., and for skylight and dome-light applications.

These rod actuators are powerful, economical and capable of withstanding high maximum loads (from 200 to 2000 N) and provide a wide range of opening and closing strokes (up to 500 mm).

Benefits:

- Compact and silent operation
- Cost-effective
- Maintenance-free
- Easy to install
- Rigid rod movement

Figure 21

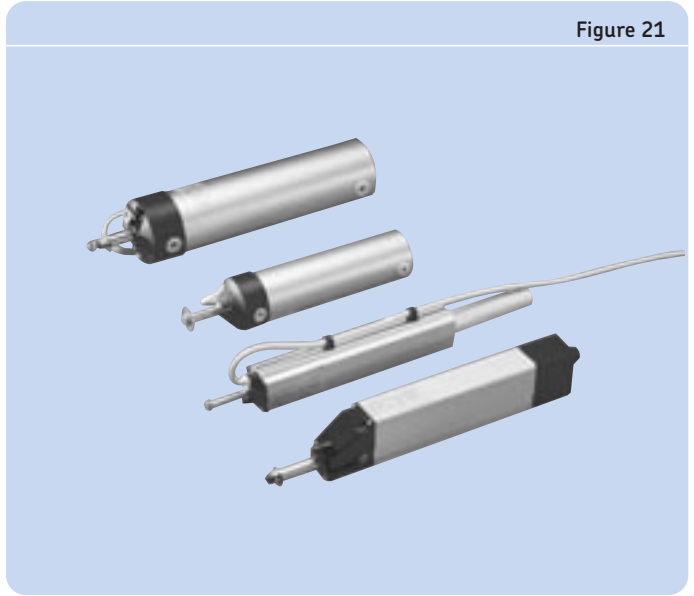

Type	Force		Max. speed		Stroke (S)	Retr. Length (L)	Voltage	Protection	Weight
	push	pull	no load	full load					
	N		mm/s		mm	mm	V	IP	kg
CS10	200	200	37	30	105 - 300	278 - 393	230 AC	44	1.3
CS20	450	450	22	18	160 - 300	266 - 411	230 AC	54	1.7
CS31	500	500	24	19	200 - 400	309 - 509	230 AC	55	2.1
CS40	450	450	12	8	200 - 500	330 - 630	230 AC / 24 DC	55	1.4
CS50	1000	1000	24	21	300 - 500	415 - 615	230 AC	55	3.4
CS60	600	600	24	22	180 - 500	345 - 620	230 AC	44	3.4
CS70	2000	2000	19	14	180 - 500	278 - 598	230 AC	40	6.5

MAGTOP CS10

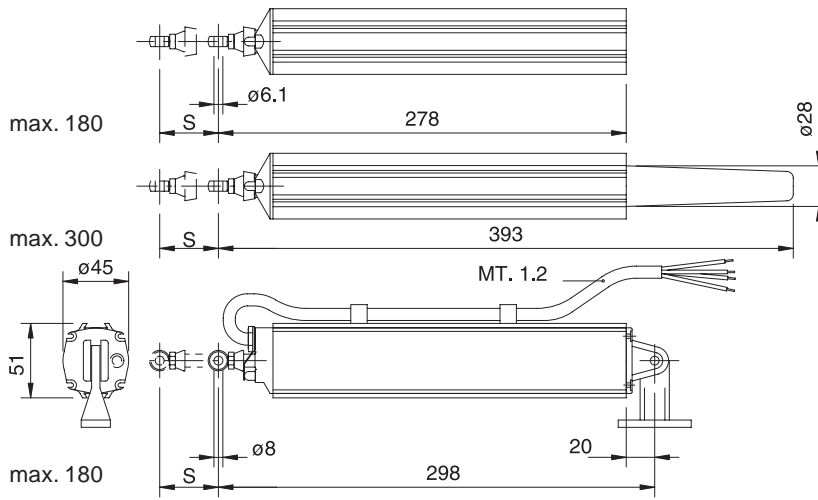

Legend:
S = stroke

Type	Force		Max. speed		Stroke (S)	Retr. Length (L)	Voltage	Protection	Weight
	push	pull	no load	full load					
	N		mm/s		mm	mm	VAC	IP	kg
CS10	200	200	37	30	105 - 300	278 - 393	230	44	1.3

Ordering key

CS **10** - - **230** - **S** - **00**

Type:

Spindle actuator CS

Load / Speed:

200 N / 37 mm/s 10

Stroke (S):

105 mm 0105
 165 mm 0165
 180 mm 0180
 240 mm 0240
 300 mm 0300

Supply voltage:

230 VAC 230

Color:

Silver EV1 S

Options:

None 00

Example: **CS** **10** - **0165** - **230** - **S** - **00**

4 Actuation systems

Linear actuators

MAGTOP CS20

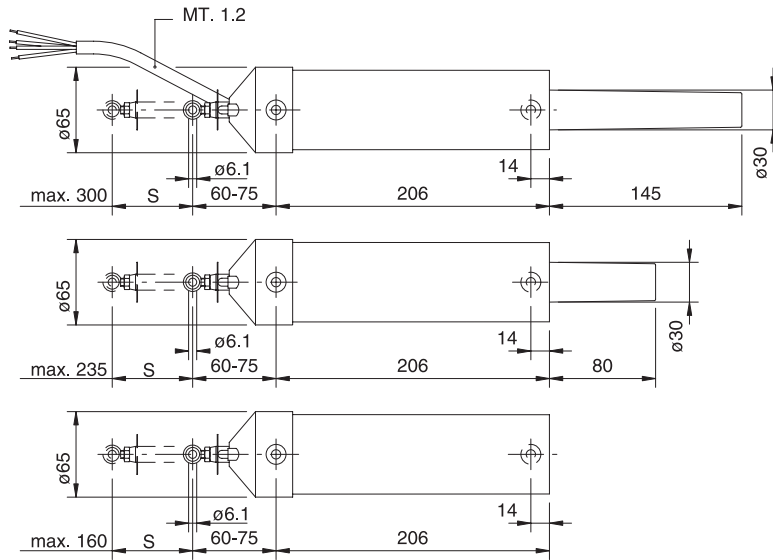

Legend:
S = stroke

Type	Force		Max. speed		Stroke (S)	Retr. Length (L)	Voltage	Protection	Weight
	push	pull	no load	full load					
	N		mm/s		mm	mm	VAC	IP	kg
CS20	450	450	22	18	160 - 300	266 - 411	230	54	1.7

Ordering key

	CS	20	-		-	230	-	S	-	00
Type: Spindle actuator	CS									
Load / Speed: 450 N / 22 mm/s		20								
Stroke (S): 160 mm..... 180 mm..... 200 mm..... 235 mm..... 300 mm.....										0160 0180 0200 0235 0300
Supply voltage: 230 VAC						230				
Color: Silver EV1.....								S		
Options: None										00

Example: CS 20 - 0180 - 230 - S - 00

MAGTOP CS31

Legend:
S = stroke
L = retracted length

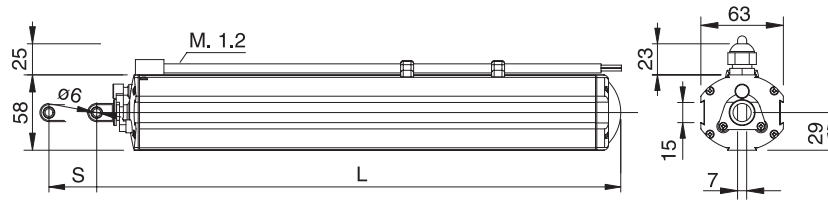

S	L
200	308.8
300	408.8
400	508.8

Type	Force		Max. speed		Stroke (S)	Retr. Length (L)	Voltage	Protection	Weight
	push	pull	no load	full load					
	N		mm/s		mm	mm	VAC	IP	kg
CS31	500	500	24	19	200 - 400	309 - 509	230	55	1.8

Ordering key

CS 31 - [] - 230 - S - 00

Type:
Spindle actuator CS

Load / Speed:
500 N / 24 mm/s 31

Stroke (S):
200 mm 0200
300 mm 0300
400 mm 0400

Supply voltage:
230 VAC 230

Color:
Silver EV1 S

Options:
None 00

Example: CS 31 - 0200 - 230 - S - 00

4 Actuation systems

Linear actuators

MAGTOP CS40

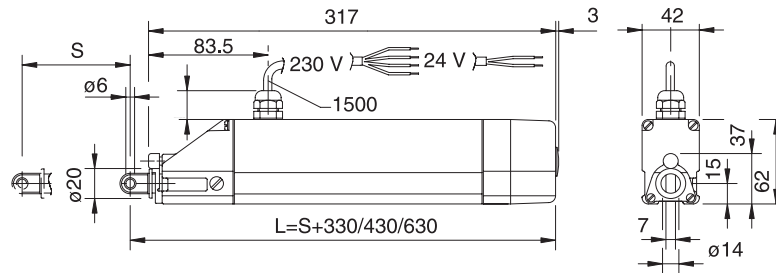

Legend:
S = stroke
L = retracted length

Type	Force		Max. speed		Stroke (S)	Retr. Length (L)	Voltage	Protection	Weight
	push	pull	no load	full load					
	N		mm/s		mm	mm	V	IP	kg
CS40	450	450	12	8	200 - 500	330 - 630	230 AC 24 DC	55	1.4

Ordering key

	CS	40	-		-		-	S	-	00
Type: Spindle actuator	CS									
Load / Speed: 450 N / 12 mm/s		40								
Stroke (S): (adjustable from 1 mm to max. length)										
200 mm						0200				
300 mm						0300				
500 mm						0500				
Supply voltage:										
230 VAC							230			
24 VDC							024			
Color: Silver EV1								S		
Options: None										00

Example: CS 40 - 0300 - 024 - S - 00

MAGTOP CS50

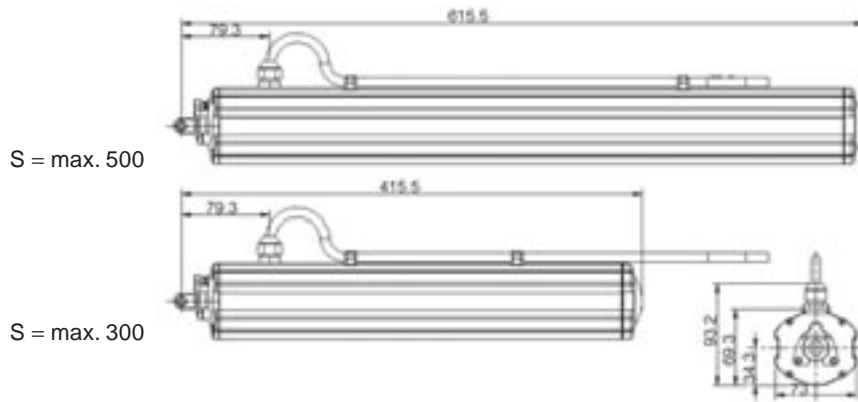

Legend:
S = stroke

Type	Force		Max. speed		Stroke (S)	Retr. Length (L)	Voltage	Protection	Weight
	push	pull	no load	full load					
	N		mm/s		mm	mm	VAC	IP	kg
CS50	1000	1000	24	21	300 - 500	415 - 615	230	55	3.4

Ordering key

CS 50 - [] - 230 - S - 00

Type:
Spindle actuator CS

Load / Speed:
1000 N / 24 mm/s 50

Stroke (S):
300 mm 0300
500 mm 0500

Supply voltage:
230 VAC 230

Color:
Silver EV1 S

Options:
None 00

Example: CS 50 - 500 - 230 - S - 00

4 Actuation systems

Linear actuators

MAGTOP CS60

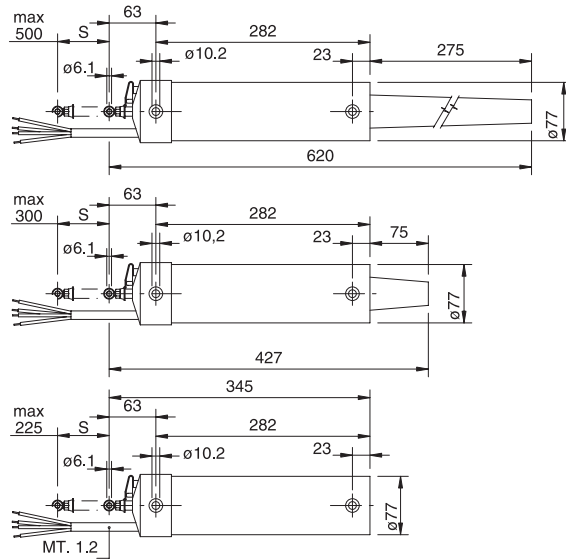

Legend:
S = stroke

Type	Force		Max. speed		Stroke (S)	Retr. Length (L)	Voltage	Protection	Weight
	push	pull	no load	full load					
	N		mm/s		mm	mm	VAC	IP	kg
CS60	600	600	24	22	180 - 500	345 - 620	230	44	3.4

Ordering key

	CS	60	-		-	230	-	S	-	00
Type: Spindle actuator	CS									
Load / Speed: 600 N / 24 mm/s		60								
Stroke (S): 180 mm..... 225 mm..... 300 mm..... 500 mm.....										0180 0225 0300 0500
Supply voltage: 230 VAC						230				
Color: Silver EV1.....								S		
Options: None										00

Example: CS 60 - 0225 - 230 - S - 00

MAGTOP CS70

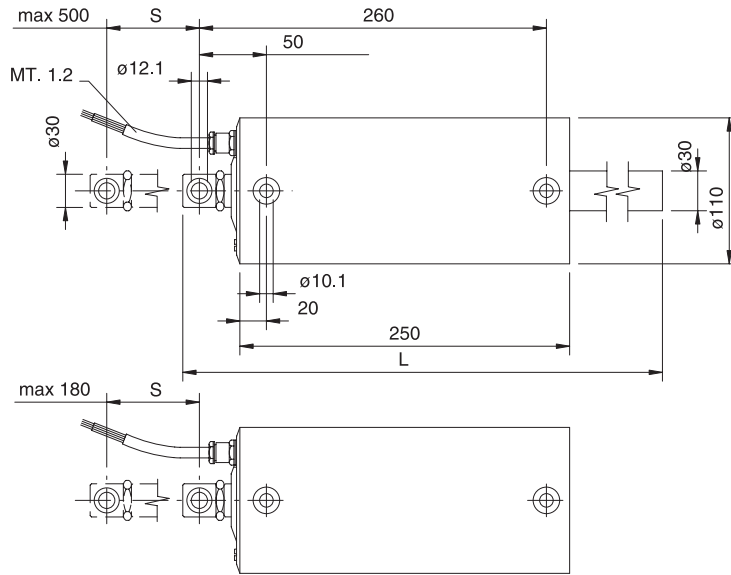

Legend:
S = stroke

Type	Force		Max. speed		Stroke (S)	Retr. Length (L)	Voltage	Protection	Weight
	push	pull	no load	full load					
	N		mm/s		mm	mm	VAC	IP	kg
CS70	2000	2000	19	14	180 - 500	278 - 598	230	40	6.5

Ordering key

CS 70 - [] - 230 - S - 00

Type:
Spindle actuator CS

Load / Speed:
2000 N / 19 mm/s 70

Stroke (S):
180 mm 0180
300 mm 0300
400 mm 0500

Supply voltage:
230 VAC 230

Color:
Silver EV1 S

Options:
None 00

Example: CS 70 - 0180 - 230 - S - 00

4 Actuation systems

Linear actuators

VARIMAG CC

The VARIMAG product family (→ **figure 22**) is a compact and cost-effective actuator, primarily designed for the building and construction segment. VARIMAG chain actuators are the ideal solution for automatically controlled windows. They take up very little space and the comprehensive range provides the correct strokes, thrust forces and chain resistance required for all window application.

Benefits:

- Compact and silent
- Cost-effective
- Take up minimum space
- Easy to install

Figure 22

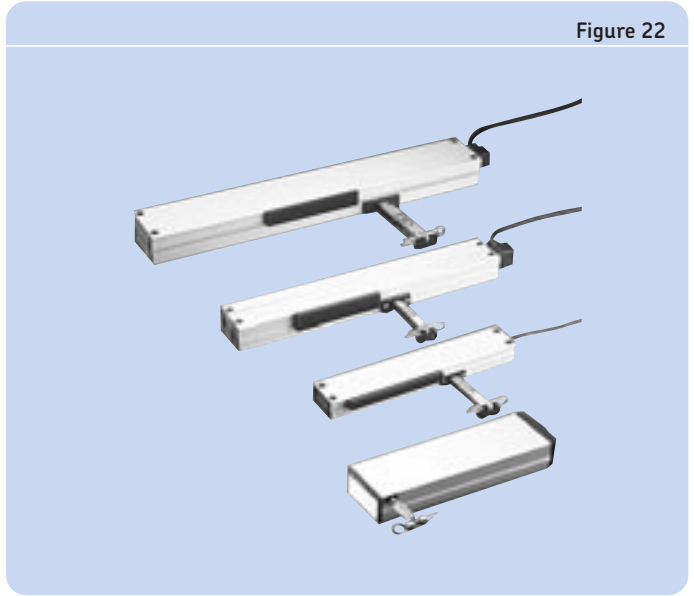

Type	Force		Max. speed		Stroke (S)	Retr. Length (L)	Voltage	Protection	Weight
	push	pull	no load	full load					
	N		mm/s		mm	mm	V DC/AC	IP	kg
CC10	150	300	45	38	130 - 380	N/A	24/230	20	1.6 - 1.8
CC20	200	200	17	10	200 - 250	N/A	24/230	20	1.0
CC30	250	250	32/28	28/26	400	N/A	24/230	22	1.0
CC40	350	350	19	15	280 - 380	N/A	24/230	22	1.8
CC50	400	400	28/38	17/22	420 - 835	N/A	24/230	22	3.5 - 4.0

VARIMAG CC10

Legend:
S = stroke

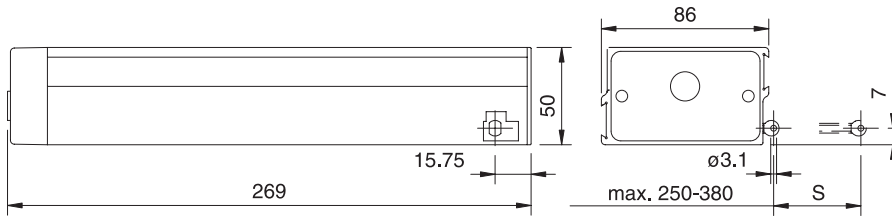

Type	Force		Max. speed		Stroke (S)	Retr. Length (L)	Voltage	Protection	Weight
	push	pull	no load	full load					
	N		mm/s		mm	mm	VDC/AC	IP	kg
CC10	150	300	45	38	130 - 380	N/A	24/230	20	1.6 - 1.8

Ordering key

CC 10 - [] - [] - [] - 00

Type:

Chain actuator CC

Load / Speed:

150 N (push), 300 N (pull) / 45 mm/s 10

Stroke (S):

130 mm 0130

150 mm 0150

250 mm / 380 mm 0380

Supply voltage:

230 VAC 230

24 VDC 024

Color:

Silver EV1 S

White RAL 9016 W

Options:

None 00

Example: CC 10 - 0150 - 024 - W - 00

4 Actuation systems

Linear actuators

VARIMAG CC20

230 V

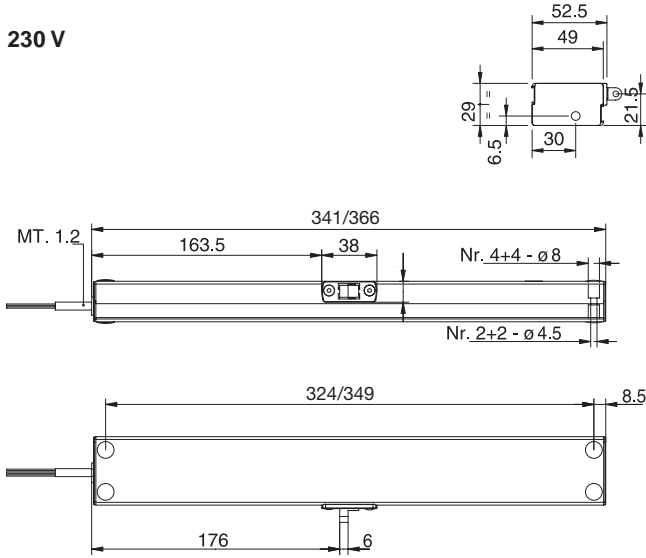

24 V

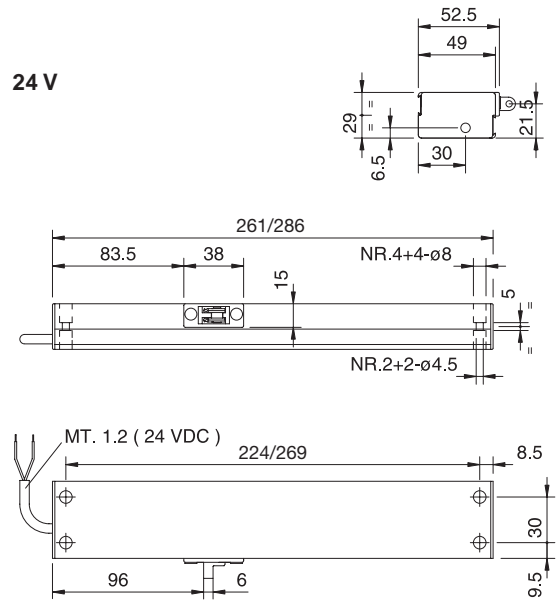

Type	Force		Max. speed		Stroke (S)	Retr. Length (L)	Voltage	Protection	Weight
	push	pull	no load	full load					
	N		mm/s		mm	mm	V DC/AC	IP	kg
CC20	200	200	17	10	200 - 250	N/A	24/230	20	1.0

Ordering key

	CC	20	-		-		-		-	00
Type: Chain actuator.....	CC									
Load / Speed: 200 / 17 mm/s		20								
Stroke (S): 200 mm..... 250 mm.....						0200 0250				
Supply voltage: 230 VAC								230		
24 VDC								024		
Color: Silver EV1..... White RAL 9016									S W	
Options: None										00

Example: CC 20 - 0200 - 024 - S - 00

VARIMAG CC30

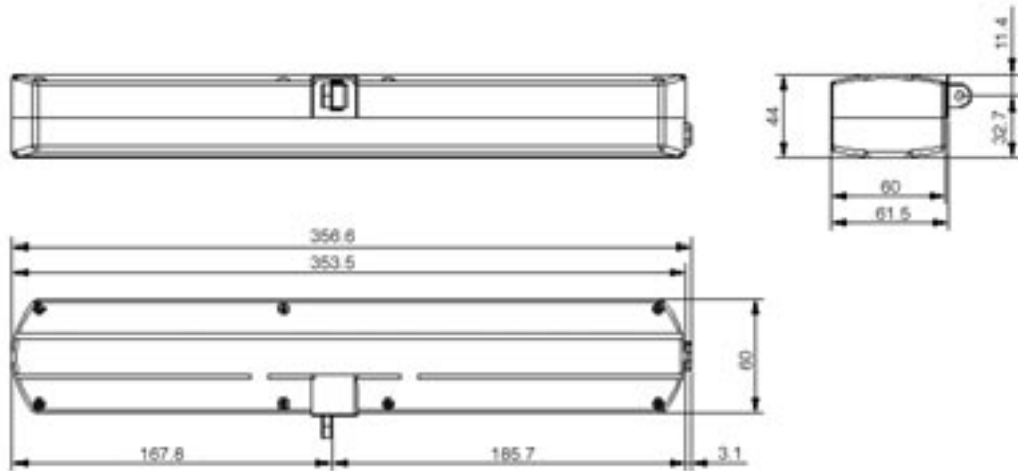

4

Type	Force		Max. speed		Stroke (S)	Retr. Length (L)	Voltage	Protection	Weight
	push	pull	no load	full load					
	N		mm/s		mm	mm	VDC/AC	IP	kg
CC30	250	250	32/28	28/26	400	N/A	24/230	22	1.0

Ordering key

CC 30 - 0400 - [] - [] - 00

Type:

Chain actuator CC

Load / Speed:

250/32/28 mm/s 30

Stroke (S):

400 mm (adjustable in 12.5 mm steps) 0400

Supply voltage:

230 VAC 230

24 VDC 024

Color:

Silver EV1 S

Black B

White W

Options:

None 00

Example: CC 30 - 0400 - 024 - B - 00

4 Actuation systems

Linear actuators

VARIMAG CC40

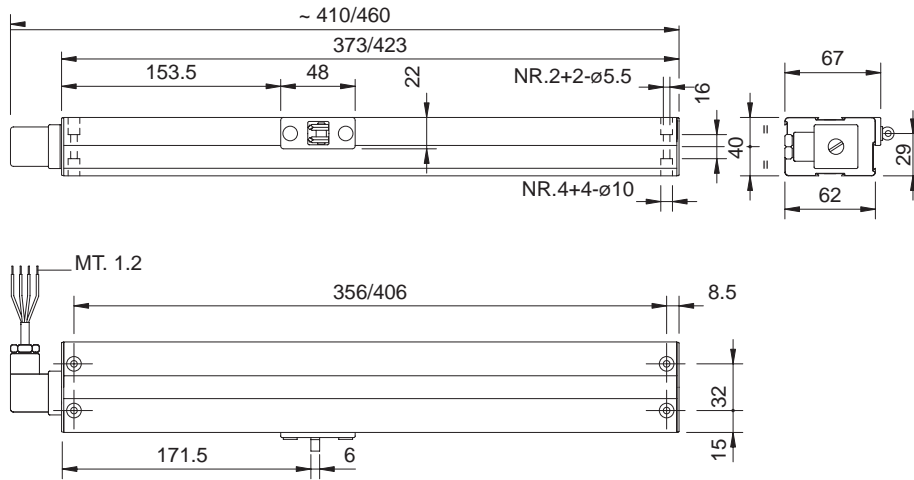

Type	Force		Max. speed		Stroke (S)	Retr. Length (L)	Voltage	Protection	Weight
	push	pull	no load	full load					
	N		mm/s		mm	mm	VDC/AC	IP	kg
CC40	350	350	19	15	280-380	N/A	24/230	22	1.8

Ordering key

	CC	40	-	-	-	-	00
Type: Chain actuator.....	CC						
Load / Speed: 350 / 19 mm/s.....		40					
Stroke (S): 280 mm..... 380 mm.....				0280 0380			
Supply voltage: 230 VAC..... 24 VDC.....						230 024	
Color: Silver EV1..... White RAL 9016.....							S W
Options: None.....							00

Example: CC 40 - 0280 - 230 - S - 00

VARIMAG CC50

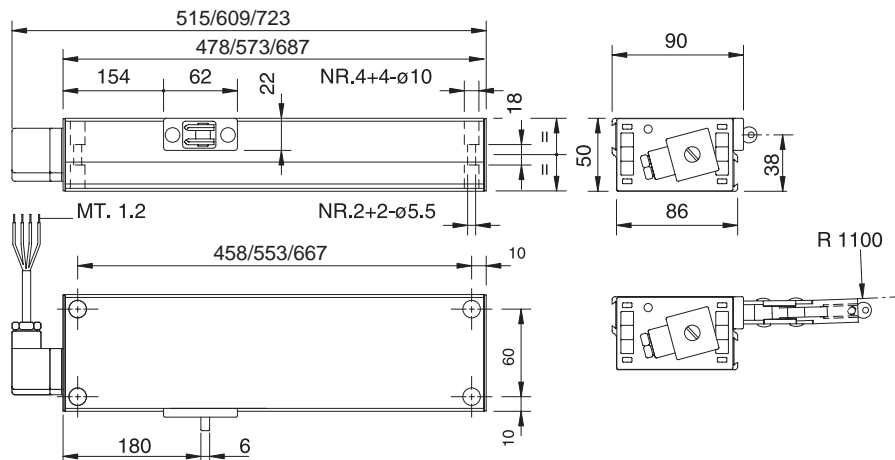

Type	Force		Max. speed		Stroke (S)	Retr. Length (L)	Voltage	Protection	Weight
	push	pull	no load	full load					
	N		mm/s		mm	mm	VDC/AC	IP	kg
CC50	400	400	28/38	17/22	420 - 600	N/A	24/230	22	3.5
CC50	200	400	17	18	835	N/A	24	22	4.0

Ordering key

	CC	50				00
Type: Chain actuator.....	CC					
Load / Speed: 400 N/17/38 mm/s		50				
Stroke (S): 420 mm.....			0420			
600 mm.....			0600			
835 mm (push force: 200 N), only with 24 VDC			0835			
Supply voltage: 230 VAC				230		
24 VDC				024		
Color: Silver EV1.....					S	
White RAL 9016					W	
Options: None						00

Example: CC 50 - 0835 - 024 - W - 00

4 Actuation systems

Linear actuators

MAGRACK CK

MAGRACK rack actuators (→ figure 23) are designed for the building and construction segment, especially for large window applications. They are ideal for heavy-duty applications in corrosive environments. They are also extremely flexible to use as they have been designed to provide synchronised thrust at two, three or four points. The ability to combine two motors to provide double thrust force should not be undervalued. The advance of the thrust

points is always perfectly synchronised thanks to the mechanical link provided by the linking bar.

Benefits:

- Compact and silent operation
- Cost-effective
- Maintenance-free
- Easy to install
- Tandem operation possible
- Resistance to atmospheric agents

Figure 23

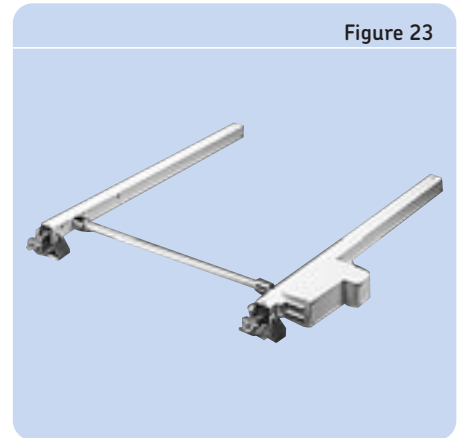

Ordering key

Type:

Rack actuator CK

Design model:

Rack without motor 10
 Motor only 20
 Rack with motor 30
 Two (2) racks with one (1) motor (tandem system)* 40
 Two (2) racks with two (2) motors (tandem system)* 50

Stroke (S):

180 mm 0180
 230 mm 0230
 350 mm 0350
 550 mm 0550
 750 mm 0750
 1000 mm 1000
 Only motor CK 20 0000

Motor voltage:

Without motor (selection of CK 10) 000
 230 V AC (not applicable for CK 10, max. force: 600N) 230
 24 V DC (not applicable for CK 10, max. force: 800 N) 024

Color:

Silver EV1 S
 White RAL 9016 (only for CK 20) W

Options:

None 00

*Linking bar not supplied, see code on the next page

Example: **CK** - **40** - **0550** - **024** - **S** - **00**

Type	Force		Max. speed		Stroke (S)	Retr. Length (L)	Voltage	Protection	Weight
	push	pull	no load	full load					
	N		mm/s		mm	mm	VDC/AC	IP	kg
CK10	N/A	N/A	N/A	N/A	180 - 1000	S+145	N/A	N/A	0.7 - 1.8
CK20	N/A	N/A	N/A	N/A	N/A	N/A	24/230	55	1.1
CK30	800/600	800/600	12/7	10/5	180 - 1000	S+145	24/230	55	1.4/2.7
CK40	800/600	800/600	12/7	10/5	180 - 1000	S+145	24/230	55	1.4/2.7
CK50	1600/1200	1600/1200	12/7	10/5	180 - 1000	S+145	24/230	55	1.4/2.7

MAGRACK CK - 24 VDC

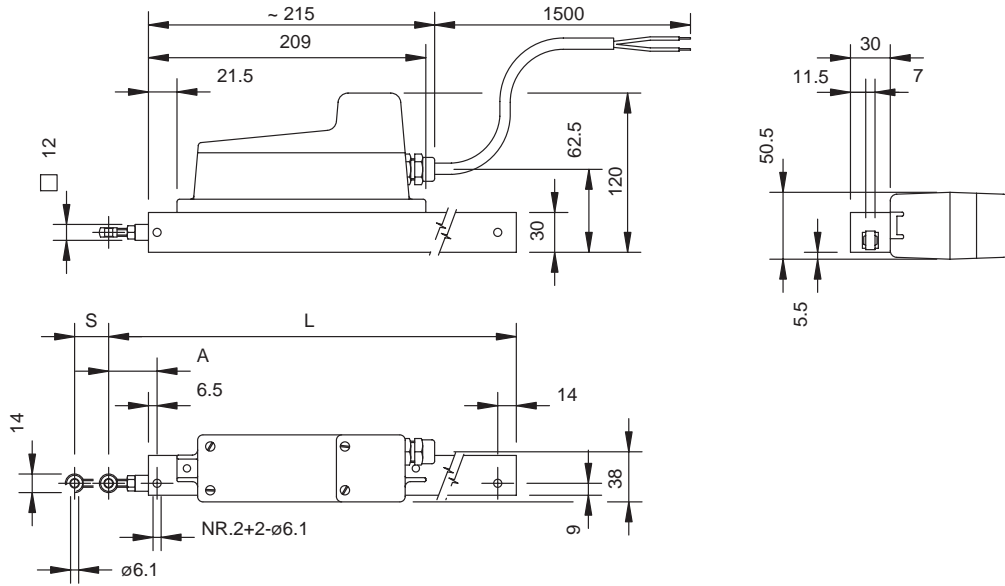

Legend:
S = stroke
L = retracted length

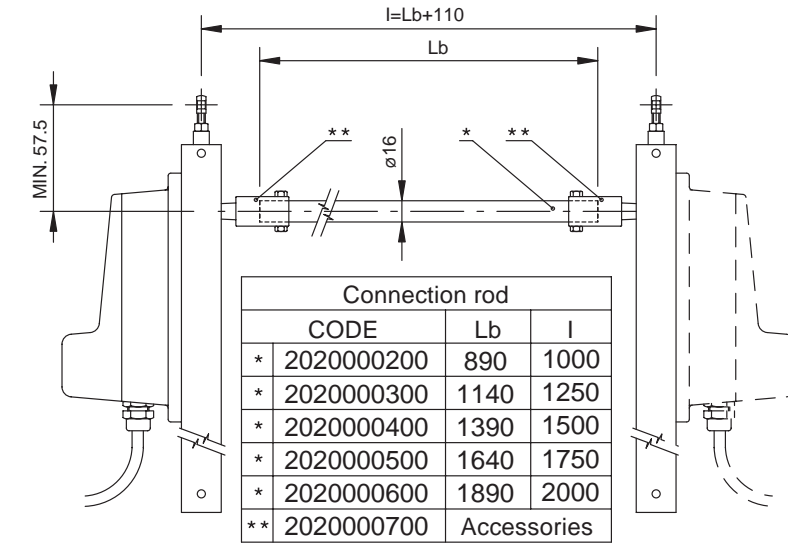

A00565

Pin four louvre casing
levers and sunshade
levers

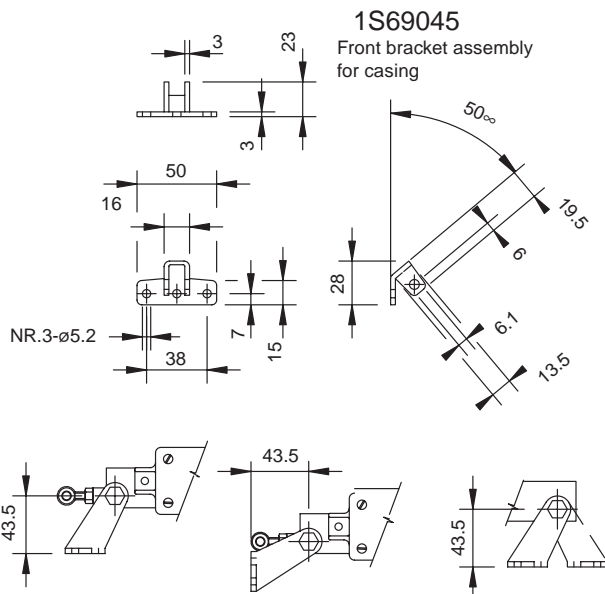
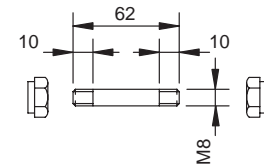

1S69045

Front bracket assembly
for casing

(CD9068)

Side pin

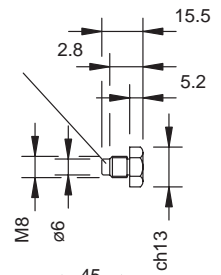

1S69048

Slating bracket
assembly

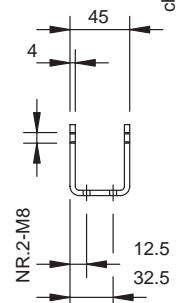
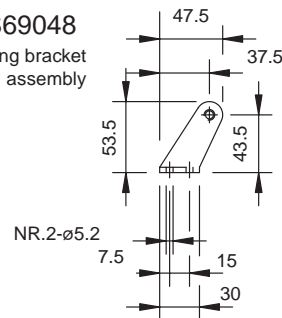

4 Actuation systems

Linear actuators

MAGRACK CK - 230 VAC

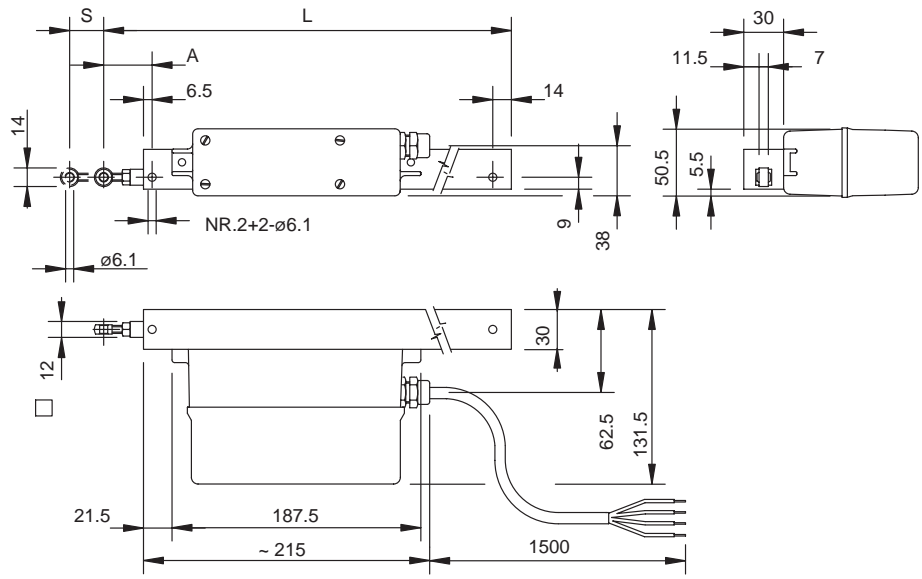

Legend:
S = stroke
L = retracted length

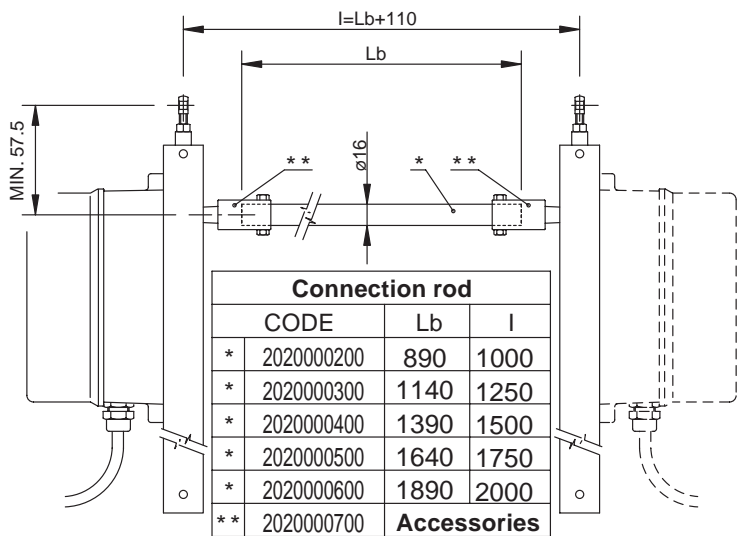

A00565

Pin four louvre casing
levers and sunshade
levers

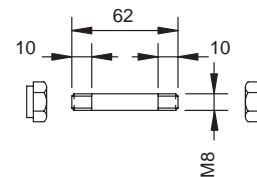

1S69048

Slating bracket assembly

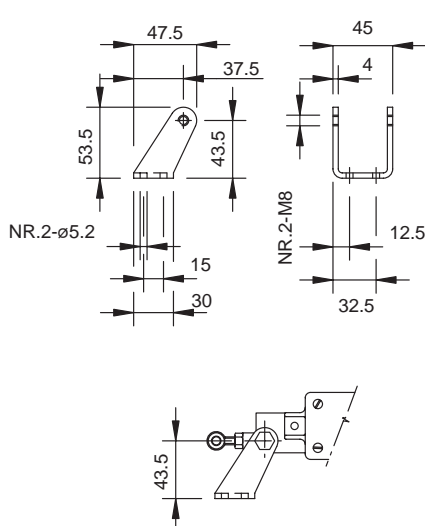

(CD9068)

Side pin

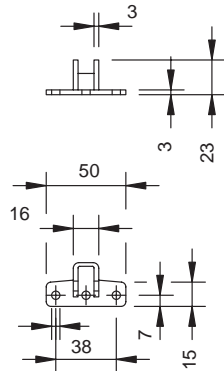

1S69045

Front bracket assembly
for casing

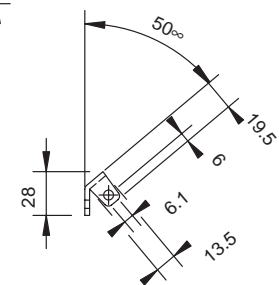



4 Actuation systems

Rotary actuators

Rotary actuators

CRAB 17

The CRAB 17 (→ **figure 24**) rotary actuator is modular so that critical components can be interchanged to meet the needs of a special design priority. The purpose with CRAB 17 is designed to be small and compact but still be able to produce high torque. As the actuator can withstand high loads it can also serve as a load-bearing element of your design.

Special bearings arrangements are not usually required.

Benefits:

- Multiple output shafts
- Multiple motor options
- Small and compact

Figure 24

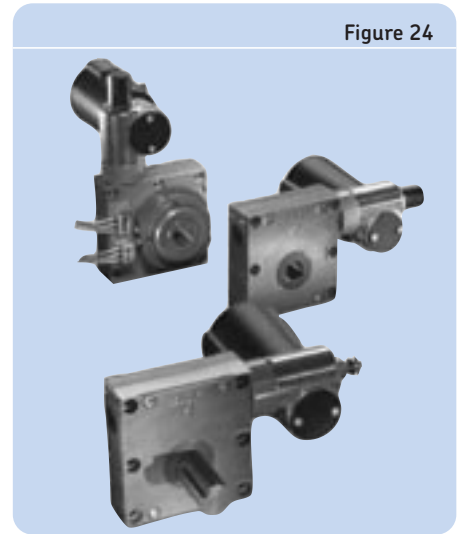

Type	Torque	Max. speed	Size	Working range	Voltage	Protection	Weight
	Nm	rpm	mm	degrees	V	IP	kg
CRAB 17	70	8	125	multi turn	120/230 AC	20/44	3
CRAB 17	105	20	125	multi turn	12/24/90 DC	20/44	3

Standard shaft design

Type key code: 1

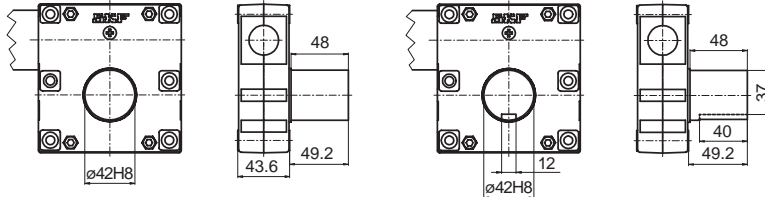

Type key code: 2

Type key code: 3

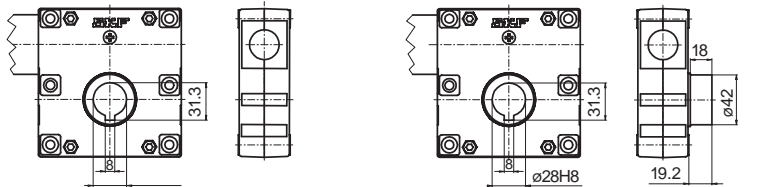

Type key code: 4

Limit switch

Type key code: S

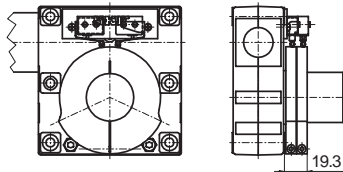

Manual override

Type key code: B

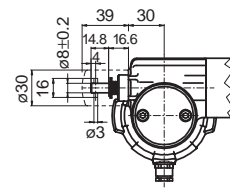
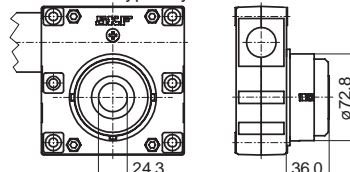

Type key code: A

Motor options

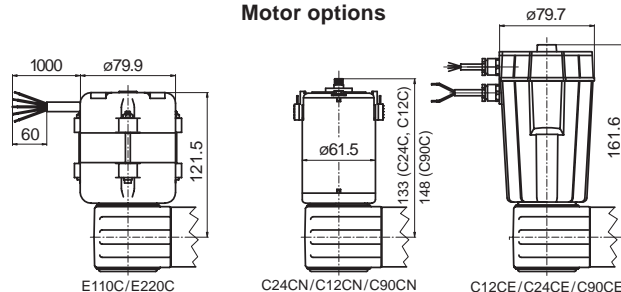

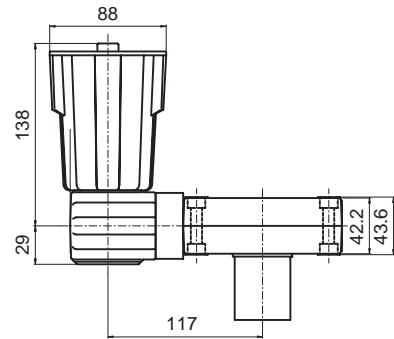
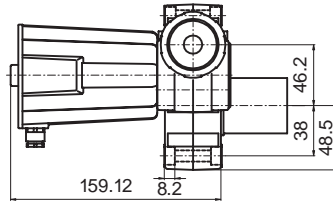
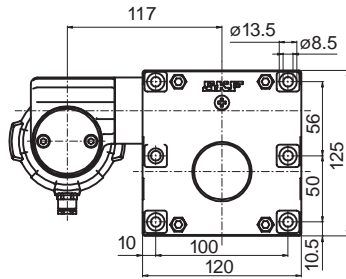

CRAB 17x - x 1- x RL / CxxC -

Ordering key

Dynamic load / Speed (N)/(mm/s)			Motor options	
60/30	38/58	19/110	12 VDC	C12C
60/30	38/58	19/110	24 VDC	C24C
105/30	53/55	38/110	90 VDC	C90C
70/13	40/27	22/52	120 VAC/60 Hz	E110C
55/13	34/27	18/52	230 VAC/50 Hz	E220C
1	2	4		

CRAB17 × [] × [] × [] / [] []

Type

Manual override:

- None -
- Hand crank A
- Release on shaft B

Shaft design:

- Solid 1
- Solid / keyway 2
- Hollow / keyway 3
- Hollow / keyway for limit switch 4
- Hollow / splines (with override for shaft type "B") 5
- Customer specification 6

Limit switch:

- No -
- Yes (fits shaft N° 1, 2, 4 and 5) S

Motor orientation:

- Rear R
- Upwards U
- Front F
- Downwards D

Motor assembly:

- Right R
- Left L

Options for CxxC motors:

- No cable -
- Encoder E
- Motor without cover N
- EMC filter M
- Straight, 2.0 m T2
- Jack plug 2.0 m T2P

Example: CRAB17 × 4 A × 1 S × R L / C 24 C T2 P

4 Actuation systems

Rotary actuators

CRAB 05

The design of the CRAB 05 rotary actuator series (→ **figure 25**) has been developed from a completely new recliner technology. This recliner technology is a new patent and has been successfully used in the automotive industry for car seat applications. Car seat applications demand low cost, high operation, high impact strength and ease of operation, electrically or manually, when adjusting the seat. This design makes it possible to build low cost and space saving solutions in application where dynamic force demands are below 100 Nm.

Benefits:

- Recliner
- Multiple motor options
- Thin and small

Figure 25

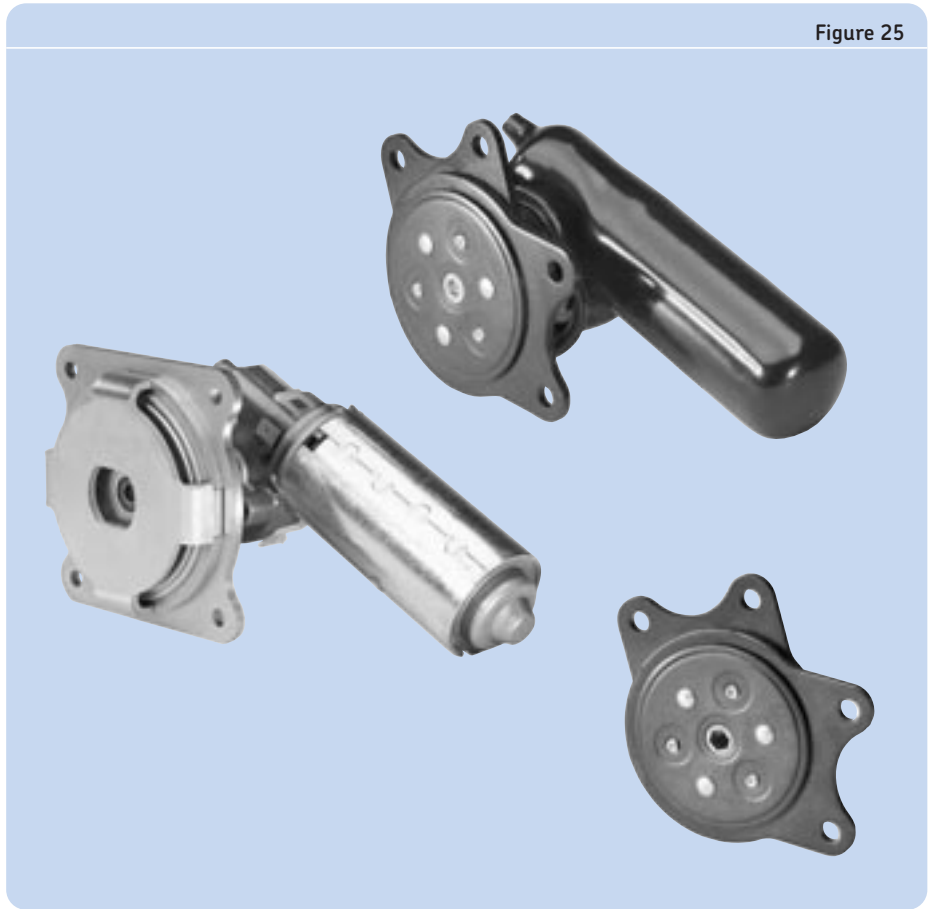

Type	Torque	Max. speed	Size	Working range	Voltage	Protection	Weight
	Nm	rpm	mm	degrees	VDC	IP	kg
CRAB 05	100	3	86	multi turn	24	20	0,5

CRAB05

Motor MH

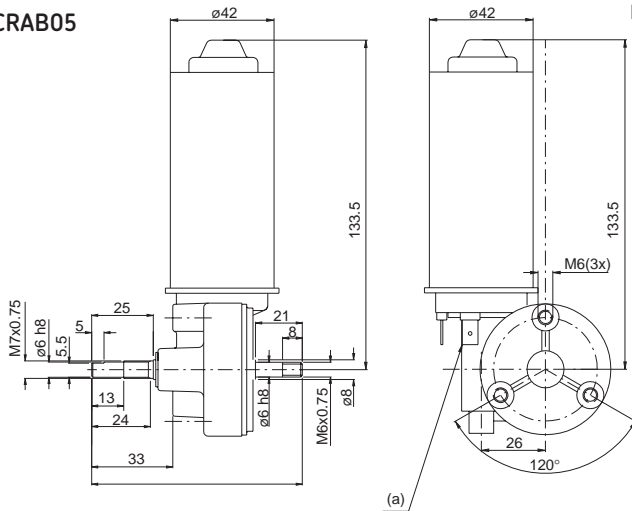

Legend:
 (a) = Blade terminal
 6.3 x 0.8 DIN 46244
 (b) = Drive cross not fixed to gear. Hardened 45HRC

Motor MD

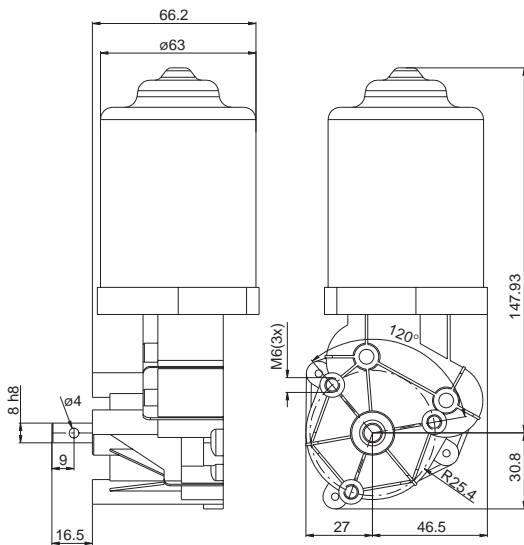

Fig. A

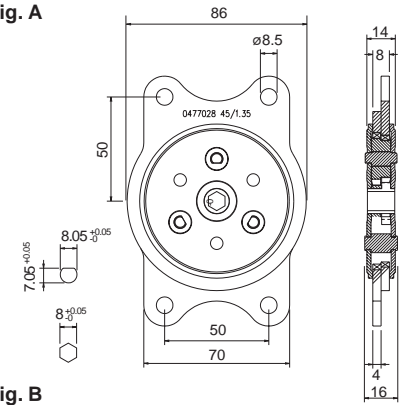
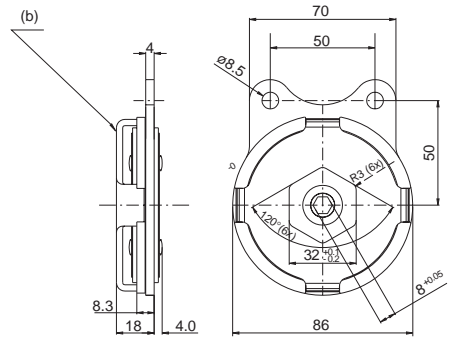
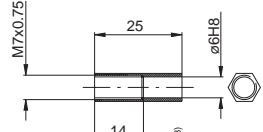

Fig. B



Connecting shaft SH



Connecting shaft SD

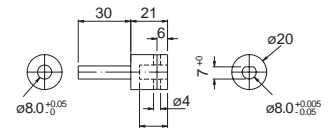

Ordering key

Type

Coating:

Black chromium-plated B
 Natural chromium-plated C

Motor shaft connection:

D-hole D
 Hexagonal hole H

Attachment/connection:

Outer connection ears (see Fig. A) E
 Centre connection hexagonal 32 mm (see Fig. B only option "C" and "H") S

Motors:

No motor 00
 24 V DC for motor shaft connection "D" MD
 24 V DC for motor shaft connection "H" MH

Connection shaft:

No shaft 00
 D-shaft SD
 Hexagonal shaft SH

CRAB05 | | | | |

Example: **CRAB05 C D E M D S H**

4 Actuation systems

Control units

Control units

A large variety of control units (→ **figure 26**) is available to operate the linear drives and telescopic pillars. They allow the connection of up to 5 actuators or several external options. There is also a version to operate battery powered DC-actuators.

For combinations of actuators and control units please see the matrix on **page 165**.

Benefits:

- Application focused system control
- Operation of up to 5 actuators
- Connections for foot, hand or desk switches
- Basic functions or encoder processing versions

Figure 26



Control units	Type	Control	Max. motor connections	Input	Output
			n°	V	V/A
KOM	KOM 1	Basic functions	4	230/120	24/6
	KOM 2	Encoder processing	5	230/120	24/6 or 12
	KOM 3	Basic functions	3	230/120	24/6
	KOM 3T	Basic functions	2	230/120	24/9
	KOM 6	Encoder processing	4	230/120	24/6 or 12
MCU	MCU	Basic functions	2	24	24/6
LD	LD-015	Encoder processing	2	230/120	24/10
	LD-014	Encoder processing	4	230/120	24/12
SEM	SEM 1	Basic functions	4	230/120	24/5
CAFC 04	M1	Encoder processing	1	230/120/240	40/6
	M2	Encoder processing	2	230/120/240	40/6
	M3	Encoder processing	3	230/120/240	40/6
CAFM	M1	Encoder processing	1	230/120	40/6
	M2	Encoder processing	2	230/120	40/6
	M3	Encoder processing	3	230/120	40/6
CAEN	10R	Basic functions	1	230/120	24/1 - 10
	15	Basic functions	1	230	24/15
CAEV	110/220	Basic functions	1	230/120	400/200
CAED ANR	5-24R-PO	Encoder processing	1	22 - 28	24/5
	9-24R-PO	Encoder processing	1	22 - 28	24/9
CAED	3-24R	Basic functions	1	24	24/3
	5-24R	Basic functions	1	24	24/5
	9-24R	Basic functions	1	24	24/9
CAEP	10P-SL	Basic functions	1	230	24/2 - 10
	8V	Basic functions	1	230	24/10
CAEL	10-24R	Basic functions	1	230	24/2 - 10
BCU	4/5/8/9	Basic functions	3	230/120	24/7

KOM1

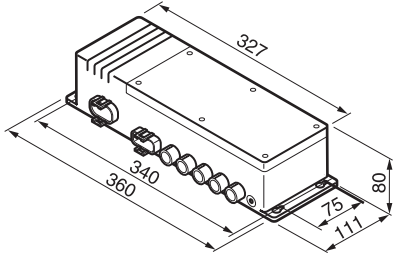

Type	Control	Max. motor connections	Input	Output
		n°	VAC	VDC/A
KOM 1	Basic functions	4	230/120	24/6

Ordering key

KOM1 - **0A** - **000**

Type

Number of channels:

1 channel	1
2 channels	2
3 channels	3
4 channels	4
2-channel with customised current cut-off	A
3-channel with customised current cut-off	B
4-channel with customised current cut-off	C

Battery option:

No battery	0
With battery and charge circuit (not possible with enhanced power)	1
With charge circuit for external battery	3

Voltage:

230 VAC, 50/60Hz	1
120 VAC, 50/60Hz	2

Cable/Connecting plug:

No.	0
-----	---

Colour:

Grey, RAL 7035	A
----------------	---

Customization:

None	000
------	-----

4

Accessories

Example: **KOM1 2** - **010A** - **000**

Item	Plug	Country	Order number	Comment
Straight cable 3.5 m	Schuko	DE	140306	
Straight cable 3.5 m	SEV	CH	140316	
Straight cable 3.5 m	UL	USA	140355	
Straight cable 3.5 m	Hospital grade	USA	140360	
Straight cable 3.5 m	British standard	UK	140350	
Coiled cable 1.2 m / 2.2 m	Schuko	DE	140342	
Coiled cable 1.2 m / 2.2 m	SEV	CH	140378	
Straight cable 3.5 m	SEV	CH	140422-3500	Polyurethane cable
Straight cable 3.5 m	Schuko	DE	140426-3500	Polyurethane cable
Tool for plugs (Jack/D-Sub/Mains)			140375	
Operating device adaptor (DSub9)			140420	

4 Actuation systems

Control units

KOM2

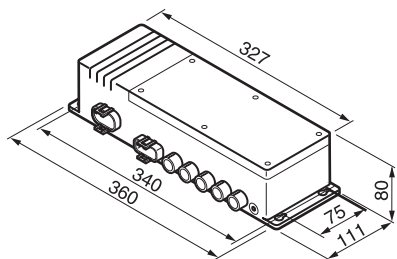

Type	Control	Max. motor connections	Input	Output
		n°	VAC	V/A
KOM 2	Encoder processing	5	230/120	24/6 or 12

Ordering key

KOM2 - 0A - 000

Type

Number of channels:

1 channel (not available with parallel option)	1
2 channels	2
3 channels	3
4 channels (not available with memory option)	4
5 channels (not available with memory option)	5

Battery option:

No battery	0
With battery and charge circuit (not possible with enhanced power)	1
With charge circuit for external battery	3

Voltage:

230 VAC, 50/60Hz	1
120 VAC, 50/60Hz	2
230 VAC, 50/60Hz with enhanced power	4
120 VAC, 50/60Hz with enhanced power	5

Cable/Connecting plug:

No cable	0
----------	---

Colour:

Grey, RAL 7035	A
----------------	---

Software options:

Up and down function (up to 5 channels)	E
Parallel operation of actuators (all connected actuators move together), 2, 3, 4 channels	P
Parallel operation of 2 × 2 actuators	D
3 free programmable memory positions	M

Customization:

None	000
------	-----

Example: KOM2 3 - 040AP - 000

Accessories

Item	Plug	Country	Order number	Comment
Straight cable 3.5 m	Schuko	DE	140306	
Straight cable 3.5 m	SEV	CH	140316	
Straight cable 3.5 m	UL	USA	140355	
Straight cable 3.5 m	Hospital grade	USA	140360	
Straight cable 3.5 m	British standard	UK	140350	
Coiled cable 1.2 m/2.2 m	Schuko	DE	140342	
Coiled cable 1.2 m/2.2 m	SEV	CH	140378	
Straight cable 3.5 m	SEV	CH	140422-3500	Polyurethane cable
Straight cable 3.5 m	Schuko	DE	140426-3500	Polyurethane cable
Tool for plugs (Jack/D-Sub/Mains)			140375	
Operating device adaptor (DSub9)			140420	

KOM3

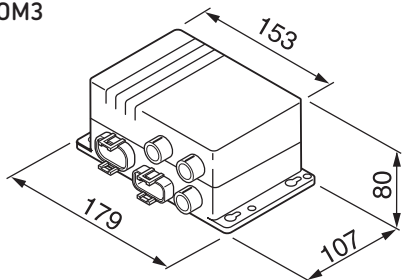

Type	Control	Max. motor connections	Input	Output
		n°	VAC	V/A
KOM 3	Basic functions	3	230/120	24/6
KOM 3T	Basic functions	2	230/120	24/9

Ordering key

Type	KOM3				
Number of channels:					
1 channel	1			
2 channels	2			
3 channels	3			
2 channels (only for TLT-Telemag)	T			
Voltage:					
230 VAC, 50/60Hz		1		
120 VAC, 50/60Hz		2		
Cable/Connecting plug:					
No.			0	
Colour:					
Grey RAL 7035				A
Customization:					
None				000

Example: KOM3 T - 1 0A - 000

Accessories

Item	Plug	Country	Order number	Comment
Straight cable 3.5 m	Schuko	DE	140306	
Straight cable 3.5 m	SEV	CH	140316	
Straight cable 3.5 m	UL	USA	140355	
Straight cable 3.5 m	Hospital grade	USA	140360	
Straight cable 3.5 m	British standard	UK	140350	
Coiled cable 1.2 m /2.2 m	Schuko	DE	140342	
Coiled cable 1.2 m /2.2 m	SEV	CH	140378	
Straight cable 3.5 m	SEV	CH	140422-3500	Polyurethane cable
Straight cable 3.5 m	Schuko	DE	140426-3500	Polyurethane cable
Tool for plugs (Jack/D-Sub/Mains)			140375	
Operating device adaptor (DSub9)			140420	



4 Actuation systems

Control units

KOM6

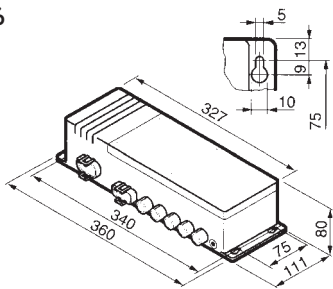

Type	Control	Max. motor connections	Input	Output
		n°	VAC	V/A
KOM 6	Encoder processing	4	230/120	24/6 or 12

Ordering key

KOM6 - 0A - 000

Type

Number of channels:

1 channel (not available with parallel option)	1
2 channels	2
3 channels	3
4 channels (not available with memory option)	4

Battery option:

No battery	0
With battery and charge circuit (not possible with enhanced power)	1
With charge circuit for external battery	3

Voltage:

230 VAC, 50/60Hz	1
120 VAC, 50/60Hz	2
230 VAC, 50/60Hz with enhanced power	4
120 VAC, 50/60Hz with enhanced power	5

Cable/Connecting plug:

Without cable	0
---------------	---

Colour:

Grey, RAL 7035	A
----------------	---

Software options:

Up and down function (up to 4 channels)	E
Parallel operation of 2 × 2 actuators	D
Parallel operation of actuators (all connected actuators move together), incl. 3 memory positions	M
3 free programmable memory positions	N

Customization:

None	000
------	-----

Accessories

Example: KOM6 4 - 140AN - 000

Item	Plug	Country	Order number	Comment
Straight cable 3.5 m	Schuko	DE	140306	
Straight cable 3.5 m	SEV	CH	140316	
Straight cable 3.5 m	UL	USA	140355	
Straight cable 3.5 m	Hospital grade	USA	140360	
Straight cable 3.5 m	British standard	UK	140350	
Coiled cable 1.2 m/2.2 m	Schuko	DE	140342	
Coiled cable 1.2 m/2.2 m	SEV	CH	140378	
Straight cable 3.5 m	SEV	CH	140422-3500	Polyurethane cable
Straight cable 3.5 m	Schuko	DE	140426-3500	Polyurethane cable
Tool for plugs (Jack/D-Sub/Mains)			140375	
Operating device adaptor (DSub9)			140420	

MCU

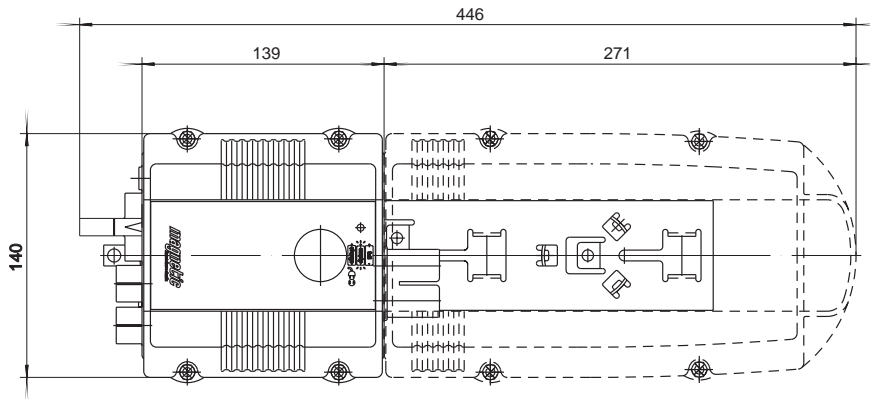

Type	Control	Max. motor connections	Input	Output
		n°	VDC	V/A
MCU	Basic functions	2	24	24/6

4

Ordering key

MCU1 - 003 - 0000

Type

Voltage:

24 V DC 1

Number of channels:

1 channel 1
 2 channels 2

Cable/Connecting plug:

Without cable 00

Colour:

Grey 3

Options:

None 000
 Cut-off current 7.5 A EWP
 Cut-off current 9 A EXP
 Emergency lowering, channel 1 EYE
 Cut-off current 7.5 A, electric emergency lowering, channel 1 2DU
 Cut-off current 9 A, electric emergency lowering, channel 1 2AT

Symbols/customization:

Not used 0000

Example: MCU1 1 - 003 EYE - 0000

Accessories

Item	Data	Plug	Order number
Battery unit	4.5 Ah		ZBA-142211
Mains adapter	230 V	Euro plug	ZDV-142331
Mains adapter	120 V	UL plug	ZDV-142332
Wall charging station			ZLA-142221
Tool for plugs (Jack/D-Sub/Mains)			140375

4 Actuation systems

Control units

LD

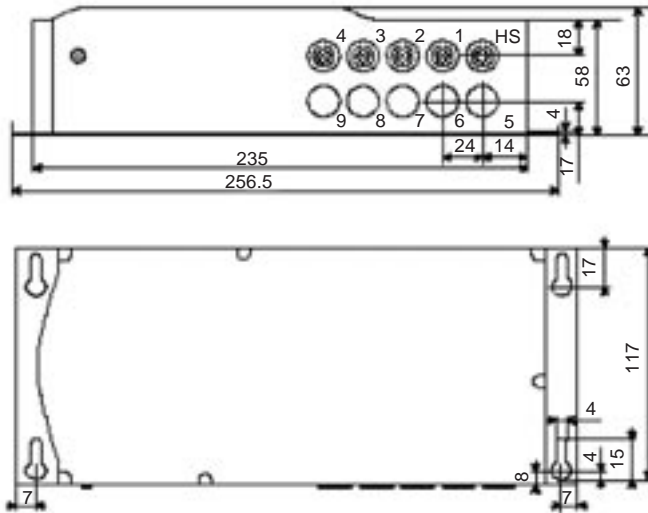

LD-014

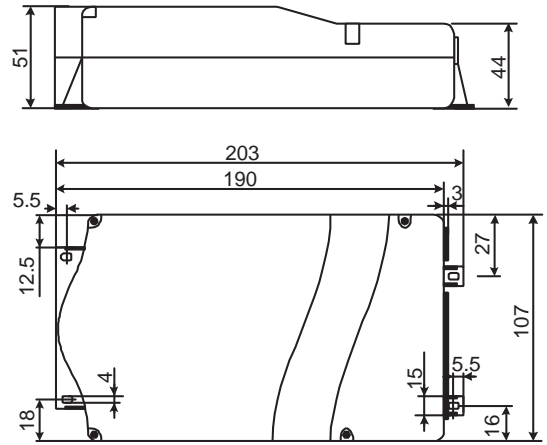

LD-015

Type	Control	Max. motor connections	Input	Output
		n°	VAC	V/A
LD-014	Encoder processing	4	230/120	24/12
LD-015	Encoder processing	2	230/120	24/10

Ordering key

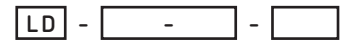

Type

Number of channels:

2 channels for TELESMAST TXG	015-005
2 channels for TMA/TMD	015-062
3 channels for TMA/TMD	014-041
4 channels for TMA/TMD	014-042

Voltage:

230 VAC	000
120 VAC	001

Example: LD - 015-062 - 001

SEM

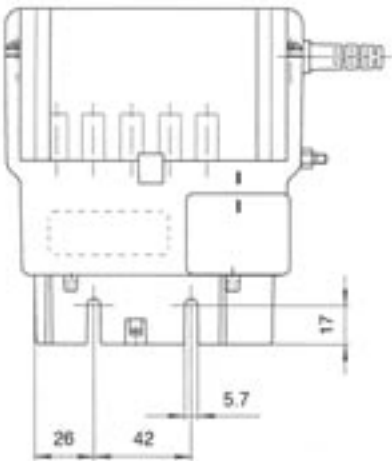

Type	Control	Max. motor connections	Input	Output
		n°	VAC	V/A
SEM	Basic functions	4	230/120	24/5

Ordering key

SEM1 - 000 - 000

Type

Number of channels:

- 2 channels 2
- 4 channels 4

Voltage/frequency:

- 230 V/50Hz. 1
- 120 V/60Hz. 2

Mains plug: Protection class II (2-pin mains plug)

- Euro (Standard) 1
- British Standard 2
- UL 3

Colours:

- Grey RAL 7035 B

Options, electrical:

- None 0

Fastening:

- Can be plugged into actuator 0

Customer-specific adaptations:

- None 000

Example: SEM1 4 - 23B00 - 000

4 Actuation systems

Control units

CAFC 04

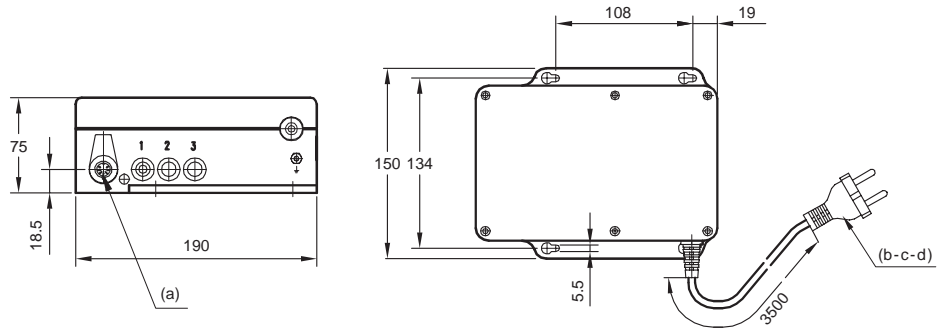

Legend:

- (a) = multi conductor locking plug DIN
- (b) = 230 V straight 3.5 m black EU
- (c) = 120 V straight 3.0 m grey US
- (d) = 240 V straight 3.0 m grey UK

Type	Control	Max. motor connections	Input	Output
		n°	VAC	V/A
M1	Encoder processing	1	230/120/240	40/6
M2	Encoder processing	2	230/120/240	40/6
M3	Encoder processing	3	230/120/240	40/6

Ordering key

CAFC04 × M 1 / X4 G

Type

Number of actuators:

1 actuator	1
2 actuators	2
3 actuators	3

Mains cable (PVC cable class II):

230 VAC, coiled cable, 3.0 m, grey, EU-plug	A
230 VAC, straight cable, 3.2 m, black, EU-plug	B
230 VAC, straight/coiled cable 3.0 m (1 m + 2 m), grey, EU-plug	G
120 VAC, straight cable, 3.0 m, grey, US-plug	H
240 VAC, straight cable, 3.0 m, grey, UK-plug	I

Overload protection (factory pre-set):

Yes	1
-----	---

Protection class:

IPX4	X4
------	----

Battery options:

No battery	0
Battery plug	2

Colour:

Grey, RAL 7035	G
----------------	---

Example: CAFC04 × M 1 × B 1 / 512 G

Accessories

Item / Product	CAF C04 M1	CAF C04 M2	CAF C04 M3
Cable handset	CAFH M1/S118C	CAFH M2/S116C	CAFH M3/S120C
	CAFH M1/S118CE	CAFH M2/S116CE	CAFH M3/S120CE
	CAFH M1/S746C	CAFH M2/S784C	CAFH M3/S822C
	CAFH M1/S746CE	CAFH M2/S784CE	CAFH M3/S822CE
Foot switch	CAFH F1/S401D	CAFH F1/S401D	CAFH F1/S402D
	CAFH F1/S403D	CAFH F1/S403D	CAFH F1/S404D
	CAFH T1/S457D	CAFH T2/S458D	
Battery	CAFB/S693D	CAFB/S693D	CAFB/S693D
Junction box	CAFR/S238D	CAFR/S238D	CAFR/S239D

CAFCM

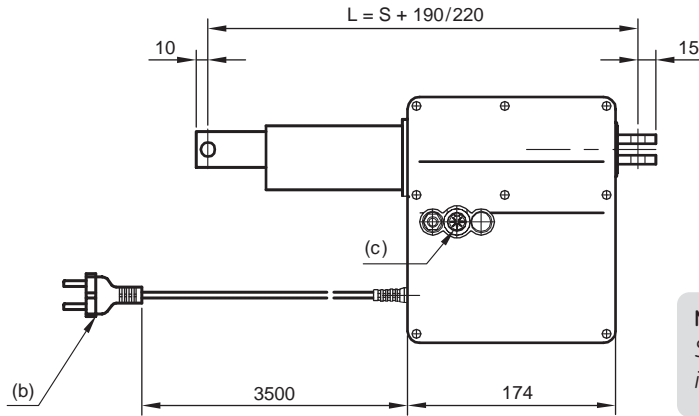
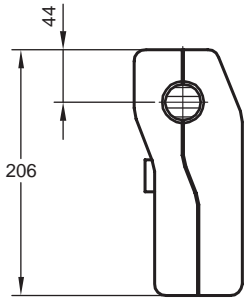
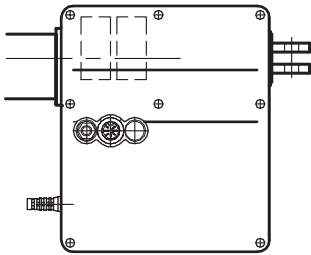
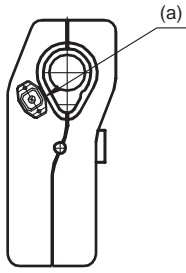

Legend:

- (a) = battery connection or external switch
- (b) = 230 VAC, coiled cable, 3.0 m, grey, EU-plug
230 VAC, straight cable, 3.2 m, black, EU-plug
230 VAC, straight/coiled cable 3.0 m (1 m + 2 m), grey, EU-plug
120 VAC, straight cable, 3.0 m, grey, US-plug
240 VAC, straight cable, 3.0 m, grey, UK-plug
- (c) = multi conductor locking plug DIN
- S = stroke (see page 228)
- L = retracted length (see page 228)

Type	Control	Max. motor connections	Input	Output
		n°	VAC	V/A
M1	Encoder processing	1	230/120	40/6
M2	Encoder processing	2	230/120	40/6
M3	Encoder processing	3	230/120	40/6

NB:
See Type key on page 229 for further information.

CAEN

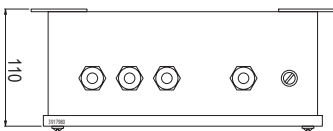
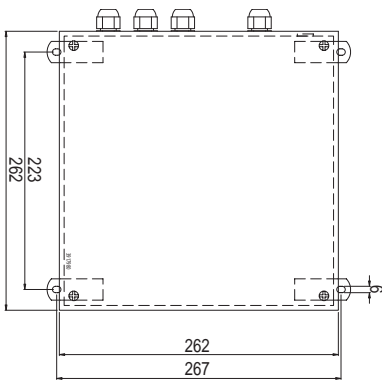

Type	Control	Max. motor connections	Input	Output
		n°	VAC	V/A
15	Basic functions (on/off)	1	230	24/15

Ordering key: **CAEN15**

4 Actuation systems

Control units

CAEN

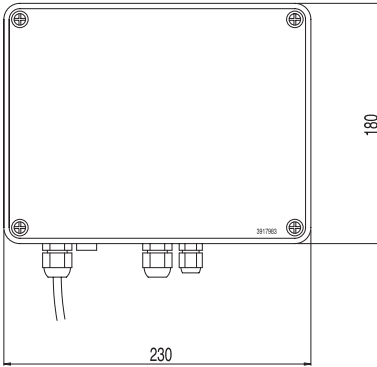
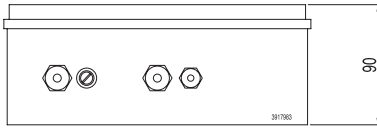

Type	Control	Max. motor connections	Input	Output
		n°	VAC	V/A DC
10R	Basic functions	1	230/120	24/1 - 10

Ordering key: **CAEN10R**

CAEV

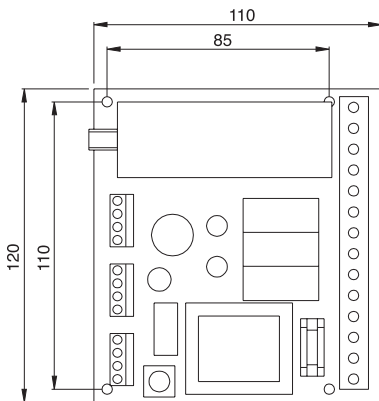
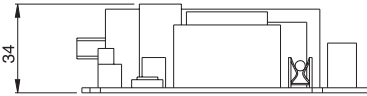

Type	Control	Max. motor connections	Input	Output
		n°	VAC	VA
110/220	Basic functions	1	230/120	400/200

Available start capacitors: values = 3 μF/4 μF/6 μF/8 μF or 12 μF

Ordering key: **CAEV 110/220**

CAED ANR

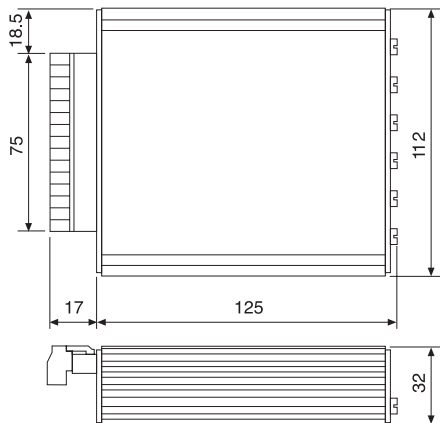

Type	Control	Max. motor connections	Input	Output
		n°	VDC	V/A
5-24R-PO	Encoder processing	1	22 - 28	24/5
9-24R-PO	Encoder processing	1	22 - 28	24/9

Ordering key: **CAED ANR 5-24R-PO**

CAED ANR 9-24R-PO

CAED

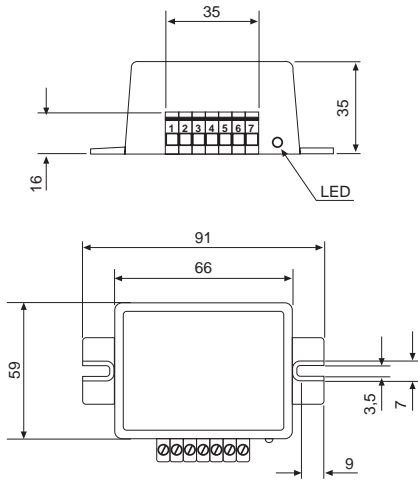

Type	Control	Max. motor connections	Input	Output
		n°	VDC	V/A DC
3-24R	Basic functions	1	24	24/3
5-24R	Basic functions	1	24	24/5
9-24R	Basic functions	1	24	24/9

Ordering key:

CAED 3-24R

CAED 5-24R

CAED 9-24R

CAEP

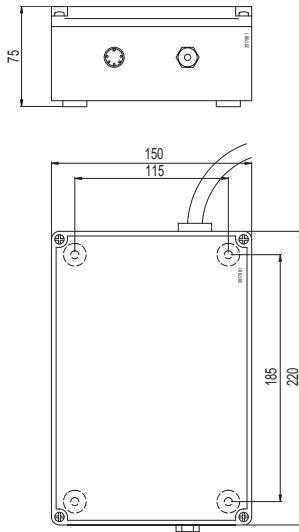

Type	Control	Max. motor connections	Input	Output
		n°	VAC	V/A DC
10P-SL	Basic functions	1	230	24/2 - 10
8V*	Basic functions	1	230	24/10

* Dimension of housing: 260 × 260 × 107 mm

Ordering key:

CAEP 10P-SL

CAEP 8V

CAEL

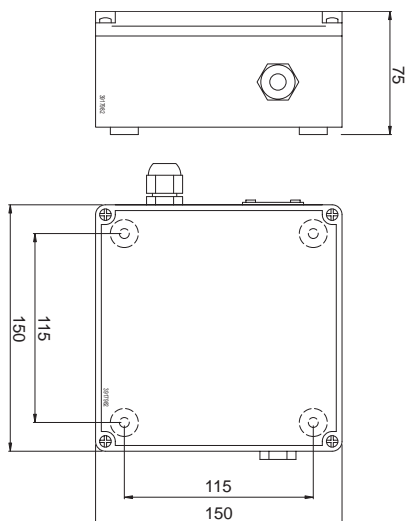

Type	Control	Max. motor connections	Input	Output
		n°	VAC	V/A DC
10-24R	Basic functions	1	230	24/2 - 10

Ordering key:

CAEL 10-24R

4 Actuation systems

Control units

BCU

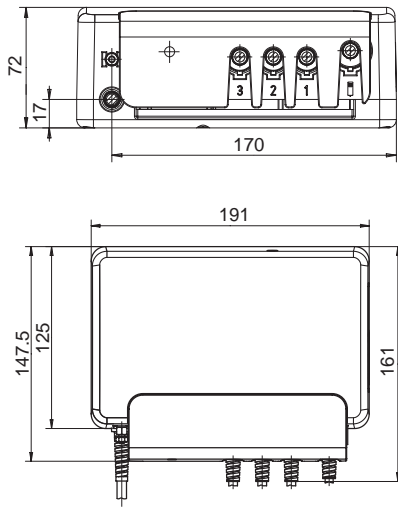

Type	Control	Max. motor connections	Input	Output
		n°	VAC	V/A DC
BCU 43	Basic functions	3	120	24/7
BCU 53	Basic functions	3	230	24/7
BCU 83	Basic functions	3	120	24/7
BCU 93	Basic functions	3	230	24/7

Ordering key

	BCU	3	-	3	1	00	-	00	00
Type:									
Voltage:									
120 VAC 50/60 Hz (Class II)									4
230 VAC 50 Hz (Class II)									8
Number of channels:									
3-channel									3
Mains power supply cable:									
Straight, 3.5 m, 2-pole plug, EU, class II									2 J
Straight, 3.5 m, 2-pole plug, UK, class II									2 H
Straight, 3.5m, 2-pole plug, UL, class II									2 M
Straight, 3.5m, 3-pole plug, UL, class I									2 L
Color/Design:									
Gray, RAL 7035									3
Option 1:									
DIN 8 motor plug and HD15 operating device plug									1
Option 2:									
None									00
Functions/symbols:									
None									00
Customer specification:									
None									00

Example: **BCU 8 3 - 2J 3 1 00 - 00 00**

Hand switches

The hand switches (→ **figure 27**) serve for operating one or several actuators. With the pushbuttons field on the front panel the movements of the actuators can be controlled easily and precisely. The hand switches are available with different plug options. There is also an infrared version for more flexibility in remote operating.

Benefits:

- Easy and precise
- Flexible and remote operation
- Ergonomic design
- Different plug options



Figure 27

4

Hand switches	Type	Operating power	Max. operating motors	Prot. class	Colour
		VDC/ mA	n°	IP	
EHA	EHA 1	12/50	4	67	grey
	EHA 2	12/50	5	67	grey
	EHA 3	12/50	4	67	grey
IHA1	IHA1	-	5	67	black
EHE	EHE 1/3	38/50	4	X7	grey/black
	EHE 6	38/50	5	X7	grey
PHC	PHC	-	4	66	grey
CAFH	M1	40/50	1	X4	black/grey
	M2	40/50	2	X4	black/grey
	M3	40/50	3	X4	black/grey
CAES	31B	30/33	1	54	black
	31C	30/33	1	54	black
	31D	30/33	1	54	black
	32D	30/33	2	54	black

4 Actuation systems

Hand switches

EHA1

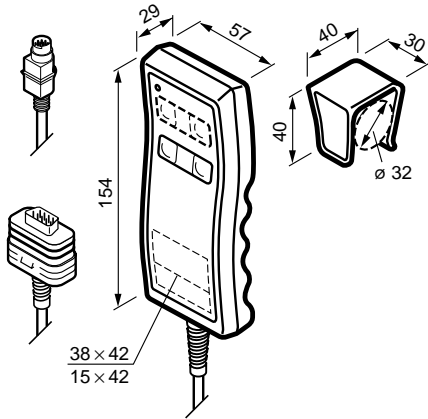

Type	Operating power	Max. operating motors	Prot. class	Colour
	VDC / mA	n°	IP	
EHA 1	12/50	4	67	grey

Item	Order number
Hook with sticker	145361-0001

Ordering key

EHA1 - 1 - 000

Type

Number of channels:

1 channel	1
2 channels	2
3 channels	3
4 channels	4

Hook:

No	0
Yes mounted with hook	1

Colour:

Grey RAL 7035	1
---------------	---

Cable/Connecting plug:

Straight, 2.5 m, D-sub 9-pin plug	A
Coiled, 1.3 m/2.3 m, D-sub 9-pin plug	B
Straight 2.5 m, (mini DIN 6-pin plug)	C
Coiled 1.0 m/2.0 m, (only possible up to 3-channel)	D
Coiled 1.8 m/2.8 m, D-sub 9-pin plug	E
Coiled 2.5 m/3.5 m, D-sub 9-pin plug	F

Symbols:

None	00
1 channel: Arrow up/down	10
Head	11
Foot	12
Level	13
2 channels: Arrow up/down	20
Head/level	21
Head/foot	22
Level/head	23
3 channels: Arrow up/down	30
Head/level/foot	31
Foot/level/head	32
4 channels: Arrow up/down	40
Head/level/foot/knee lever	41
Level/head/foot/autocontour	42

Customer logo:

Yes (position as per dimension drawing, template required)	J
No	N

Example: EHA1 3 - 01 D 23 J - 000

EHA2

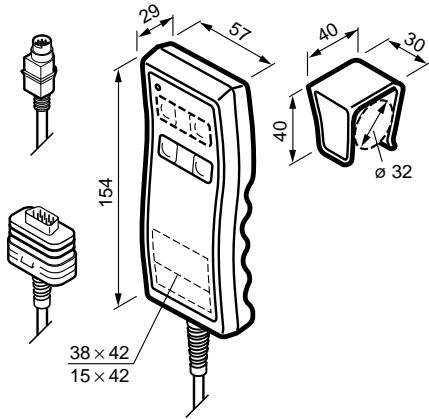

Type	Operating power	Max. operating motors	Prot. class	Colour
	VDC / mA	n°	IP	
EHA 2	12 / 50	5	67	grey

Item	Order number
Hook with sticker	145361-0001

Ordering key

EHA2 - 1 - 000

Type

Number of channels:

1 channel	1
2 channels	2
3 channels	3
4 channels	4
5 channels	5
1 channel with 3 memory functions	A
2 channels with 3 memory functions	B
3 channels with 3 memory functions	C

Hook:

No.	0
Yes mounted with hook	1
Hook supplied separately	2

Colour:

Grey RAL 7035	1
---------------	---

Cable/Connecting plug:

Straight, 2.5 m, D-sub 9-pin plug	A
Coiled, 1.3 m/2.3 m, D-sub 9-pin plug	B
Coiled 1.8 m/2.8 m, D-sub 9-pin plug	E
Coiled, 2.5 m/3.5 m, D-sub 9-pin plug	F

Symbols:

None	00
1 channel: Arrow up/down	10
Head	11
Foot	12
Level	13
2 channels: Arrow up/down	20
Head/level	21
Head/foot	22
Level/head	23
3 channels: Arrow up/down	30
Head/level/foot	31
Foot/level/head	32
4 channels: Arrow up/down	40
Head/level/foot/knee lever	41
Level/head/foot/autocontour	42
5 channels: Arrow up/down	50

Customer logo:

Yes (position as per dimension drawing, template required)	J
No	N

Example: EHA2 B - 21 A 42 N - 000

4 Actuation systems

Hand switches

EHA3

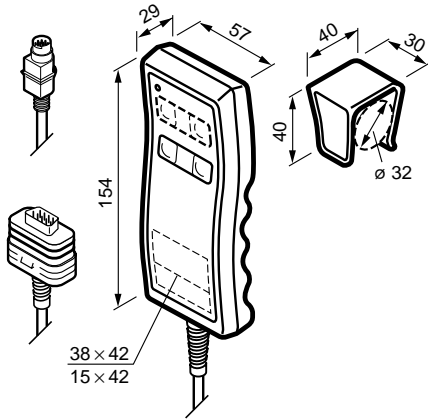

Type	Operating power	Max. operating motors	Prot. class	Colour
	VDC / mA	n°	IP	
EHA 3	12/50	4	67	grey

Item	Order number
Hook with sticker	145361-0001

Ordering key

EHA3 - 3 - 000

Type

Number of channels:

1 channel	1
2 channels	2
3 channels	3

Hook:

Hook mounted	1
Hook delivered separately	2

Colour:

Grey RAL 7035	3
---------------	---

Plug/Cable:

Straight cable 2.5 m, High Density D-sub 15p	A
Coiled cable 1.3 m/2.3 m High Density D-sub 15p	B

Symbols:

None	00
1 channel: Arrow up/down	10
Head	11
Foot	12
Level	13
Anti-trendelenburg	14
2 channels: Arrow up/down	20
Head/foot	21
Head/level	22
Level/head	23
Level/Anti-Trendelenburg	29
3 channels: Arrow up/down	30
Head/foot/level	31
Level/head/foot	32
Level/anti-trendelenburg/head	39

Customer logo:

Yes (position as per dimension drawing, template required)	J
No	N

Example: EHA3 2 - 1 3 M 13 N - 000

IHA1

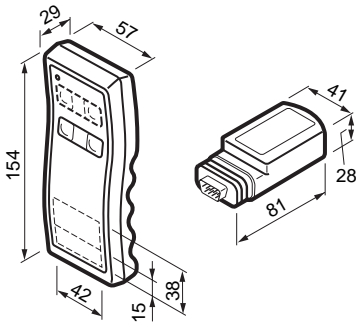

Type	Max. operating motors	Prot. class	Colour
	n°	IP	
IHA 1	5	67	black

Infrared receiver

ZDV-140210-1014, Code 1, for KOM1 and KOM3
 ZDV-140210-1024, Code 2, for KOM1 and KOM3
 ZDV-140210-2010, Code 1, for KOM2 and KOM4
 ZDV-140210-2011, Code 1, for KOM2 and KOM4 (1 channel handswitch)
 ZDV-140210-2020, Code 2, for KOM2 and KOM4
 ZDV-140210-2021, Code 2, for KOM2 and KOM4 (1 channel handswitch)

Ordering key

IHA1 - 0 - 000

Type

Number of channels:

1 channel	1
2 channels	2
3 channels	3
4 channels	4
5 channels	5
1 channel with 3 memory functions	A
2 channels with 3 memory functions	B
3 channels with 3 memory functions	C

Codes:

Code 1	1
Code 2	2

Colour of housing:

Black	0
-------	---

Symbols:

None	00
1 channel: Arrow up/down	10
Head	11
Foot	12
Level	13
2 channels: Arrow up/down	20
Head/foot	21
Head/level	22
Level/head	23
3 channels: Arrow up/down	30
Head/foot/level	31
Level/head/foot	32
4 channels: Arrow up/down	40
Head/foot/level/knee lever	41
Level/head/foot/autocontour	42
5 channels: Arrow up/down	50

Customer logo:

Yes (position as per dimension drawing, template required)	J
No	N

Customer-specific adaptations:

None	000
------	-----

Item	Order number
Hook with sticker	145361-0001

Example: IHA1 4 - 1 0 3 2 J - 000

4 Actuation systems

Hand switches

EHE 1/3

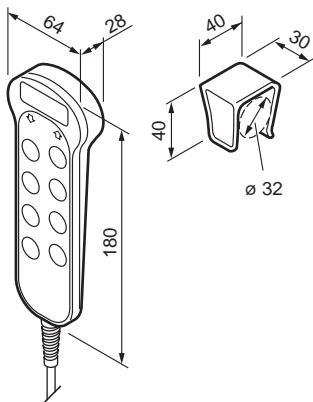

Type	Operating power	Max. operating motors	Prot. class	Colour
	VDC / mA	n°	IP	
EHE 1/3	38/50	4	X7	grey/black

Item	Colour	Order number
Hook with sticker	grey	145361-0001
Hook with sticker	black	145361-0003

Ordering key



Type:

- EHE, standard EHE1
- EHE, with locking device EHE3

Number of channels:

- 1 channel 1
- 2 channels 2
- 3 channels 3
- 4 channels 4

System of protection:

- IPX7 1

Colour:

- Black A
- Grey RAL 7035 B

Hook:

- No 0
- Yes 1

Symbols:

- 1 channel: Arrow up/down 10
- Head 11
- Foot 12
- Level 13
- 2 channels: Arrow up/down 20
- Head/level 21
- Head/foot 22
- Level/head 23
- 3 channels: Arrow up/down 30
- Head/level/foot 31
- Foot/level/head 32
- Level/head/foot 33
- 4 channels: Arrow up/down 40
- Head/level/foot/knee lever 41
- Level/head/foot/autocontour 42

Customer logo:

- Yes (position as per dimension drawing, template required) A
- No B

Example: **EHE3 4 - 1 A 0 32 A - 000**

EHE6

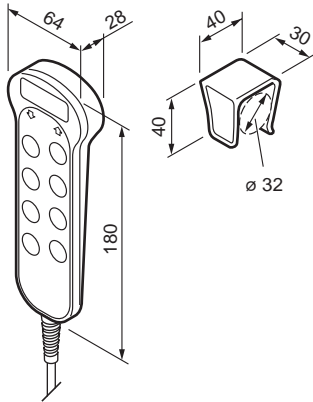

Type	Operating power	Max. operating motors	Prot. class	Colour
	VDC / mA	n°	IP	
EHE 6	38 / 50	5	X7	grey

Item	Colour	Order number
Hook with sticker	grey	145361-0001

Ordering key

EHE6 - 1 - 000

Type

Number of channels:

1 channel	1
2 channels	2
3 channels	3
4 channels	4
5 channels	5
1 channel with 3 memory functions	A
2 channels with 3 memory functions	B
3 channels with 3 memory functions	C

System of protection:

IPX7	1
------	---

Colour:

Black	A
Grey RAL 7035	B

Hook:

No	0
Yes	1

Symbols:

1 channel:	Arrow up/down	10
	Head	11
	Foot	12
	Level	13
2 channels:	Arrow up/down	20
	Head/level	21
	Head/foot	22
	Level/head	23
3 channels:	Arrow up/down	30
	Head/level/foot	31
	Foot/level/head	32
	Level/head/foot	33
4 channels:	Arrow up/down	40
	Head/level/foot/knee lever	41
	Level/head/foot/autocontour	42
5 channels:	Arrow up/down	50

Customer logo:

Yes (position as per dimension drawing, template required)	A
No	B

Example: EHE6 B - 1 A 0 4 1 B - 000

4 Actuation systems

Hand switches / Foot switches

PHC

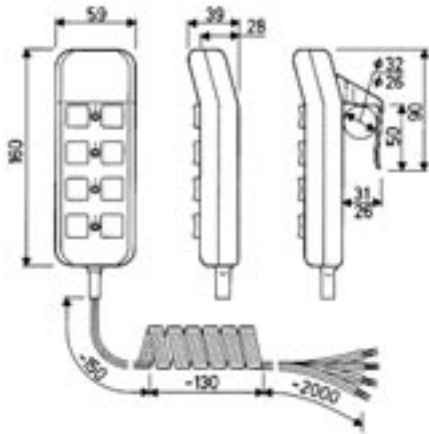

Type	Operating power	Max. operating motors	Prot. class	Colour
	VDC / mA	n°	IP	
PHC	-	4	66	grey

Type code: (for actuators with pneumatic receiver only)

PHC 1 - 130660 (1 channel)

PHC 2 - 130625 (2 channels)

PHC 3 - 130756 (3 channels)

PHC 4 - 130955 (4 channels)

Example: **PHC 3 - 130756**

CAFH

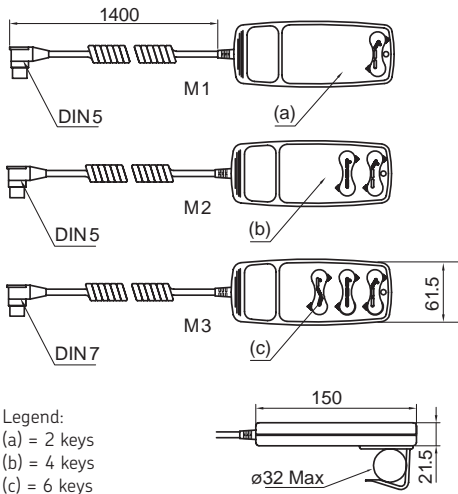

Type	Operating power	Max. operating motors	Prot. class	Colour
	VDC / mA	n°	IP	
CAFHM1	40/50	1	X4	grey / black
CAFHM2	40/50	2	X4	grey / black
CAFHM3	40/50	3	X4	grey / black

Type code: Grey Black:
 CAFHM1 / S118C S746C
 CAFHM2 / S116C S784C
 CAFHM3 / S120C S822C

CAES

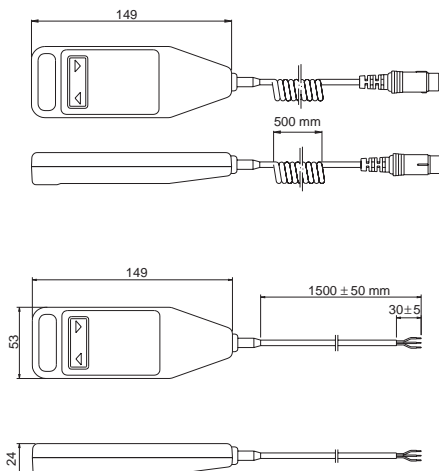

Type	Operating power	Max. operating motors	Prot. class	Colour
	VDC / mA	n°	IP	
31B	30/33	1	54**	black
31C	30/33	1	54**	black
31D*	30/33	2	54**	black
32D*	30/33	2	54**	black

* Elbowed DIN plug.
 ** According to IP class 54.

Type code:

CAES 31B (DIN 5-pole plug, 2 buttons)

CAES 31D (DIN 5-pole plug, 2 buttons, for CAFC and CAFM controls only)

CAES 32D (DIN 5-pole plug, 4 buttons, for CAFC and CAFM controls only)

CAES 31C (No connector, 2 buttons)

Foot switches

With the electrical foot switches (→ **figure 28**) direct current actuators can be operated. The large-size buttons enable an easy and precise control of the actuators. Depending on the plug the foot switches can be used on different control units.

Benefits:

- Easy and precise
- Flexible and remote operation
- Ergonomic design
- Different plug options

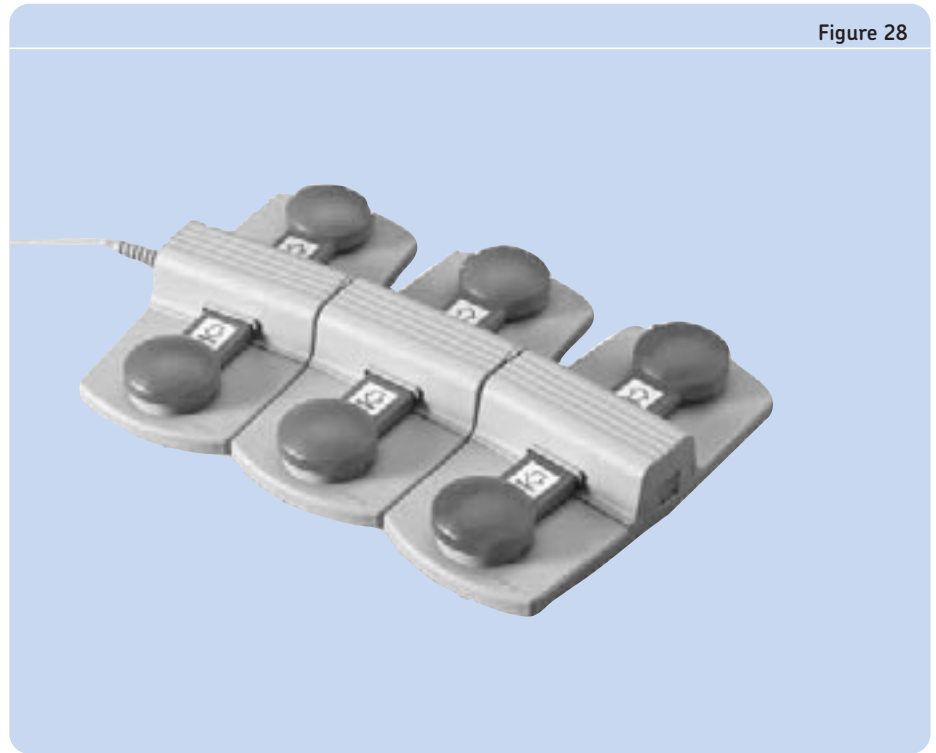

Figure 28

Foot switches	Type	Operating power	Max. operating motors	Prot. class	Colour
		VDC/ mA	n°	IP	
ST	ST	12/50	3	X5	blue/anthracite
PFP	PFP1	-	1	21	grey/anthracite
	PFP2	-	2	21	grey/anthracite
CAFHF	F1-DIN5	40/50	1	X4	anthracite
	F1-DIN7	40/50	1	X4	anthracite

4 Actuation systems

Foot switches

ST

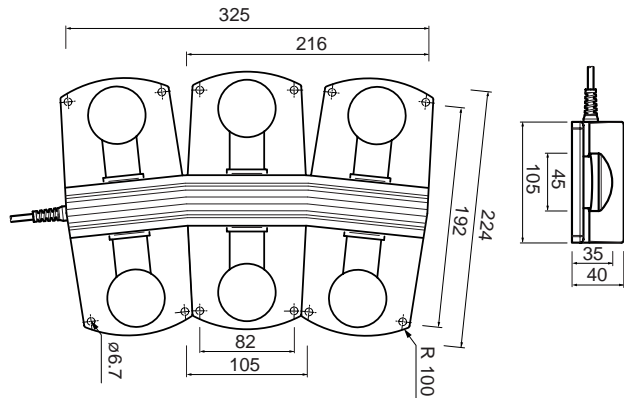

Type	Operating power	Max. operating motors	Prot. class	Colour
	VDC / mA	n°	IP	
ST	12/50	3	X5	blue/anthracite

Ordering key

	ST	0		000		00
Type						
Product group:						
Standard		F				
For microprocessor units (only for KOM2)		G				
For first failure safety units (only for KOM6)		H				
Voltage:						
Not used				0		
Number of channels:						
1 channel						1
2 channels						2
3 channels						3
Cable/Connecting plug:						
Coiled cable, 2,5 m with D-sub plug.					LU	
Coiled cable, 2,5 m with FCC plug					LV	
Colour:						
Charcoal						1
Blue (RAL5015)						4
Options:						
None						000
Symbols:						
Without symbols						00
1-3 channels: arrow up/down (on each pair of buttons)						X1
2 channels: arrow up/down, M/1 (1 memory button)						27
3 channels: arrow up/down, M/1, 2/3 (3 memory buttons)						37

Example: **ST F 0 2** - **LU 4 000** - **37 00**

Accessories

Item	Symbol	Order number	Item	Symbol	Order number
Rubber feet		ZBE-135310	Symbol sticker	level down	135309-0008
Threaded expansion inserts		ZBE-521122	Symbol sticker	head up	135309-0009
Symbol sticker	arrow up	135309-0001	Symbol sticker	head down	135309-0010
Symbol sticker	arrow down	135309-0002	Symbol sticker	foot up	135309-0011
Symbol sticker	level up	135309-0007	Symbol sticker	foot down	135309-0012

PFP

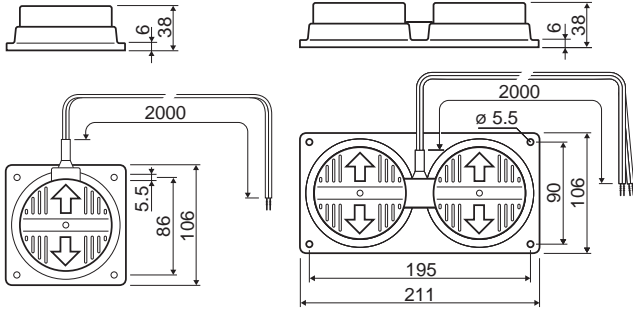

PFP 1K-130

PFP 2-130

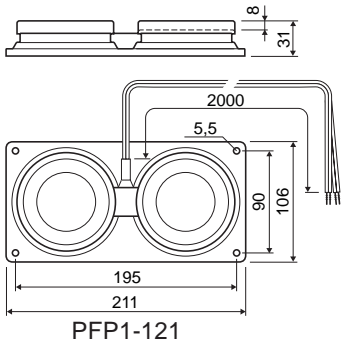

PFP1-121

Type	Operating power	Max. operating motors	Prot. class	Colour
	VDC / mA	n°	IP	
PFP 1K	N/A	1	21	grey/anthracite
PFP 1	N/A	1	21	grey/anthracite
PFP 2	N/A	2	21	grey/anthracite

Type code:

PFP 1 K - 1 3 0 6 5 2

PFP 1 - 1 2 1 5 4 5

PFP 2 - 1 3 0 5 6 0

4

CAHF

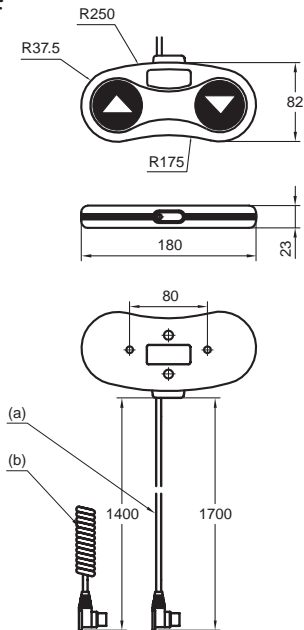

Type	Operating power	Max. operating motors	Prot. class	Colour	Suitable for
	VDC / mA	n°	IP		
F1-DIN 5	40/50	1	X4	anthracite	CAFM M1/M2 and CAFC04 M1/M2
F1-DIN 7	40/50	1	X4	anthracite	CAFM M3 and CAFC04 M3

Type code:

- CAFH F1/S401D, coiled cable, DIN 5-pole plug
- CAFH F1/S402D, coiled cable, DIN 7-pole plug
- CAFH F1/S403D, straight cable, DIN 5-pole plug
- CAFH F1/S404D, straight cable, DIN 7-pole plug

Legend:

- (a) = straight cable DIN5 or DIN7-pole-plug
- (b) = coiled cable DIN5 or DIN7-pole-plug

4 Actuation systems

Desk switches

Desk switches

The desk switches (→ **figure 29**) serve for adjusting actuators in desks, chairs, couches and other adjustable furniture. They allow to operate up to 3 actuator functions, also with memory positions, and can easily be fitted to furniture without compromising the design.

Benefits:

- Easy and precise
- Stylish design
- Memory position

Figure 29

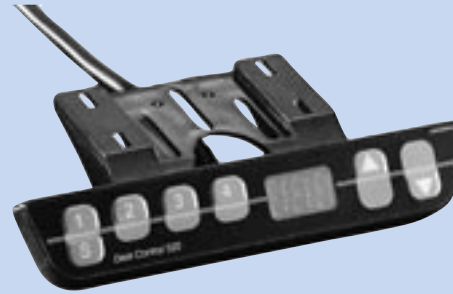

Desk switches	Type	Operating power	Max. operating motors	Prot. class	Colour
		VDC/ mA	n°	IP	
ST	ST	12/50	3	X0	black
LD	LD	5/50	2	32	black
CAFHT	T1	40/50	1	X4	black/grey
	T2	40/50	2	X4	black/grey
PAM	PAM 1-130256	-	1	-	Anthracite
	PAM 1-130348	-	1	-	Anthracite
	PAM 1-130659	-	1	-	Light grey
	PAM 1-130827	-	1	-	Light grey
	PAM 1-130966	-	1	-	Anthracite

ST

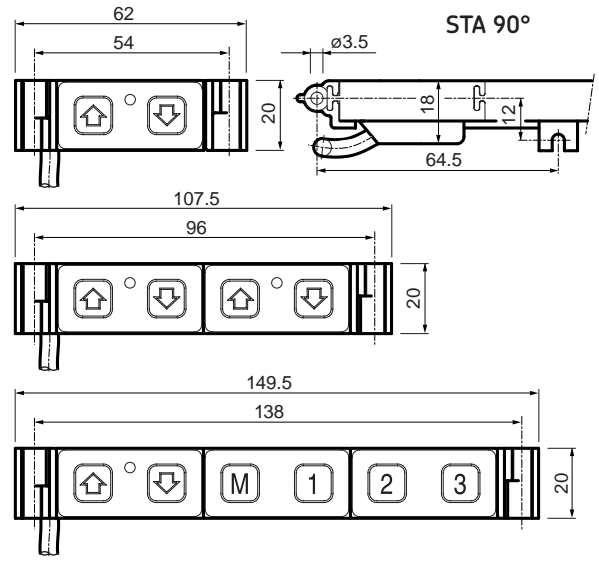
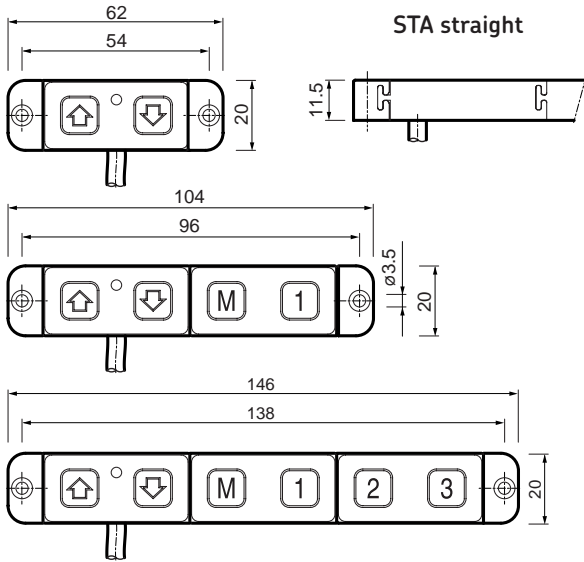

Type	Operating power	Max. operating motors	Prot. class	Colour
	VDC / mA	n°	IP	
ST	12/50	3	X0	black

Ordering key

ST 0 - 6 - 00

Type

Product group:

Standard A
 For microprocessor units (only for KOM2) C

Voltage:

Not used 0

Number of channels:

1 channel 1
 2 channels 2
 3 channels 3

Cable/Connecting plug:

Straight cable, 2.5 m with D-sub plug 0 U
 Straight cable, 1.5 m with FCC plug WV

Colour:

Black 6

Options:

No options 0 0 0
 Mounted on or underneath desktop, at a 90° angle MAU

Symbols:

Up/down (1- 3 channels) - arrow on each pair of keys X 1
 Up/down, 1 memory function, - arrow M/1 (2 channels) 2 7
 Up/down, 3 memory functions, - arrow M/1, M/2, M/3 (3 channels) 3 7

Example: ST A 0 2 - WV 6 0 0 0 - X 1 0 0

4 Actuation systems

Desk switches

LD

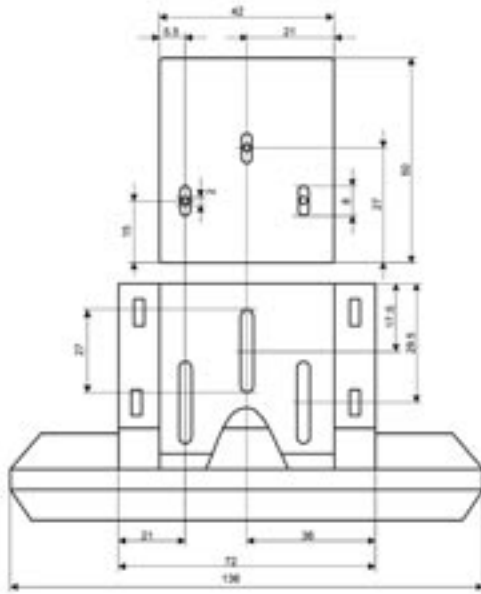

Front view:



Side view:

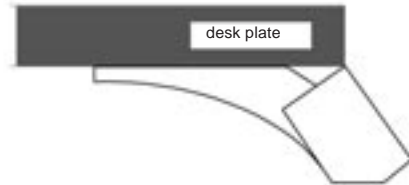

Type	Operating power	Max. operating motors	Prot. class	Colour
	VDC / mA	n°	IP	
LD	5 / 50	2	32	black

Ordering key

LD - 011 - -

Type

Channels:

1-channel, without display, for LD control units	001 - 005
1-channel, with memory keys, with display, for LD control units with FCC plug	002 - 016
1-channel, without memory and display, for TXG	001 - 006
1-channel, with memory keys, with display, for TXG	002 - 014

Example: LD - 011 - 002 - 016

CAFHT

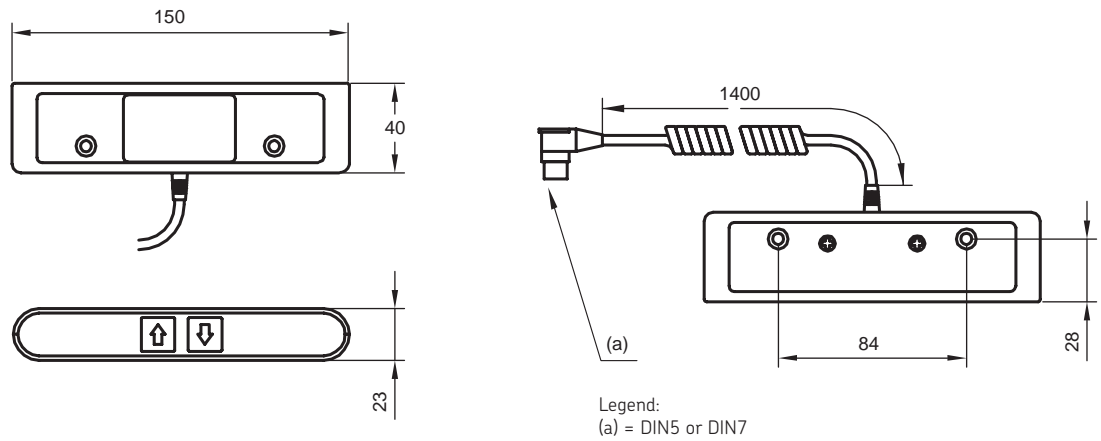

Type	Operating power	Max. operating motors	Prot. class	Colour
	VDC / mA	n°	IP	
T1	40/50	1	X4	black/grey
T2	40/50	2	X4	black/grey

Type code:

CAFHT1/S457D, 2 keys, grey
 CAFHT2/S458D, 4 keys, grey
 CAFHT1/S459D, 2 keys, black
 CAFHT2/S460D, 4 keys, black

PAM (pneumatic switch)

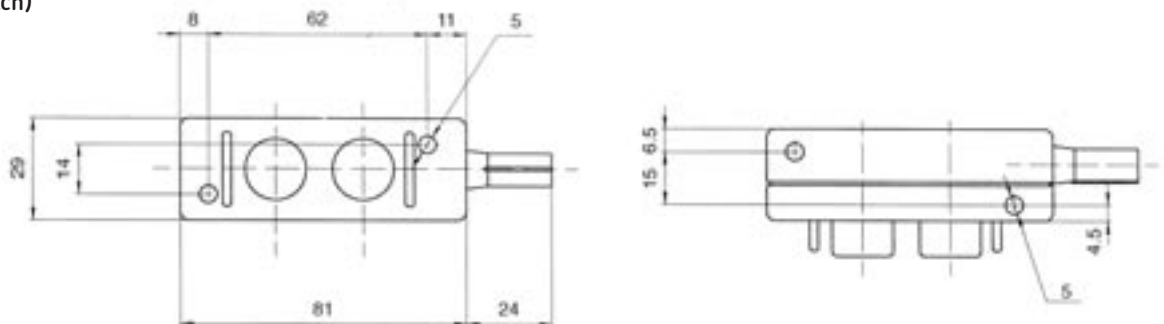

Type code	Max. operating motors	Tube	Colour
	n°	IP	
PAM 1-130827	1	none	light grey
PAM 1-130659	1	coiled 2.65 m	light grey
PAM 1-130348	1	coiled 2.65 m	anthracite
PAM 1-130256	1	straight 1.50 m	anthracite
PAM 1-130966	1	straight 3.00 m	anthracite

Junction box

The junction box (→ **figure 30**) serves to connect 2 hand, foot or table switches in a complete system. They can be used with CAFM or CAFC.

Figure 30

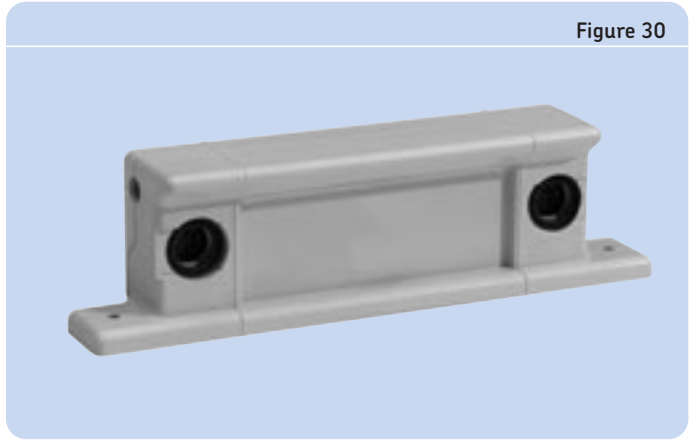

CAFR

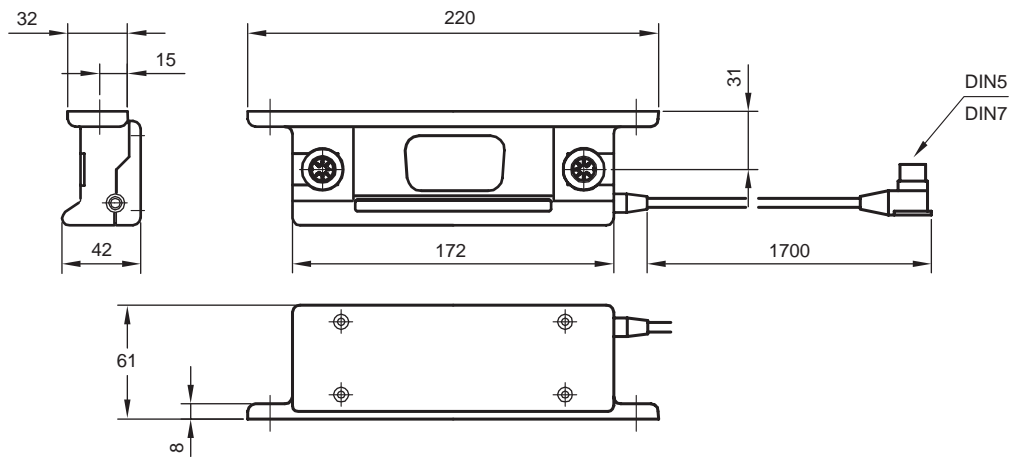

Type	Operating power	Max. operating motors	Prot. class	Colour	Suitable for
	VDC / mA	n°	IP		
DIN5	40 / 50	2	X4	grey	CAFM M1/M2 and CAFC04 M1/M2
DIN7	40 / 50	2	X4	grey	CAFM M3 and CAFC04 M3

Type code:

CAFR/S238D, DIN 5-pole

CAFR/S239D, DIN 7-pole

Easy3

SKF has put together actuator systems with component parts that are integrated to give you optimal safety and excellent reliability. Just switch the power on and you are ready for operation. The system can handle the indicated load with ease, in addition we have taken the extra precaution of building in adjustable end limits and overload protection to safeguard the equipment from impact damage (→ figure 31).

Benefits:

- Plug & play systems
- Easy to order
- Easy to install
- Easy to use

Figure 31



4

Type	Force		Speed		Stroke (S)	Retr. Length (L)	Voltage
	push	pull	no load	full load			
	N		mm/s		mm	mm	V
Easy3-02	600	600	23	12	50 - 200	S + 215	24 DC
Easy3-03	2000	2000	12	8	100 - 300	S + 150	24 DC
Easy3-04	2000	2000	12	8	100 - 300	S + 150	230 AC
Easy3-05	2000	2000	12	8	100 - 300	S + 150	230 AC
Easy3-10	7000	3000	7	4	100 - 200	S + 190	230 AC
Easy3-11	7000	3000	7	4	100 - 200	S + 190	230 AC
Easy3-12	7000	3000	7	4	100 - 200	S + 190	230 AC
Easy3-13	7000	3000	7	4	100 - 200	S + 190	230 AC

4 Actuation systems

Easy3

Easy3- 02

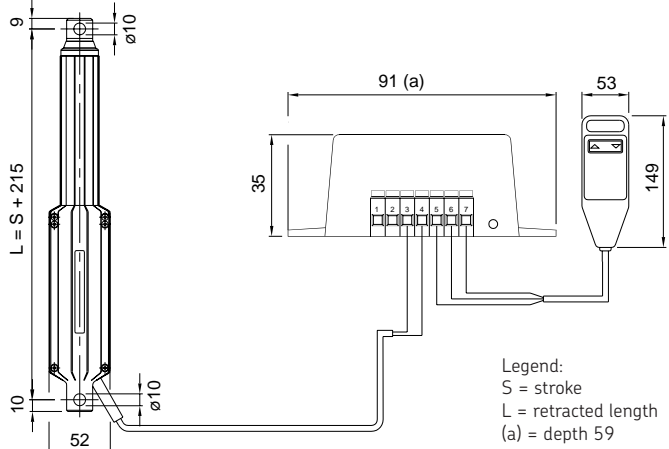

Technical data	Stroke (S)	Linear speed	Max dynamic load	Supply voltage
	mm	mm/s	N	VDC
EASY3-02	50 - 200	23 - 12	600	24

Ordering key

CALA36E302 ×

Kit type

Stroke (S):

50 mm	50
100 mm	100
200 mm	200

Example: **CALA36E302** × **200**

Easy3-03

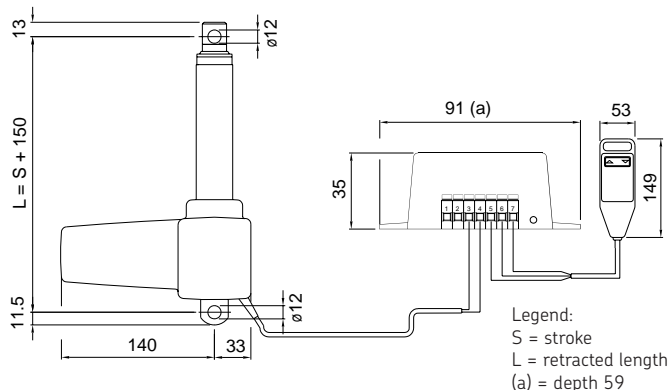

Technical data	Stroke (S)	Linear speed	Max dynamic load	Supply voltage
	mm	mm/s	N	VDC
EASY3-03	100 - 300	12 - 8	2000	24

Ordering key

CARE33E303 ×

Kit type

Stroke (S):

100 mm	100
200 mm	200
300 mm	300

Example: **CARE33E303** × **300**

Easy3- 04

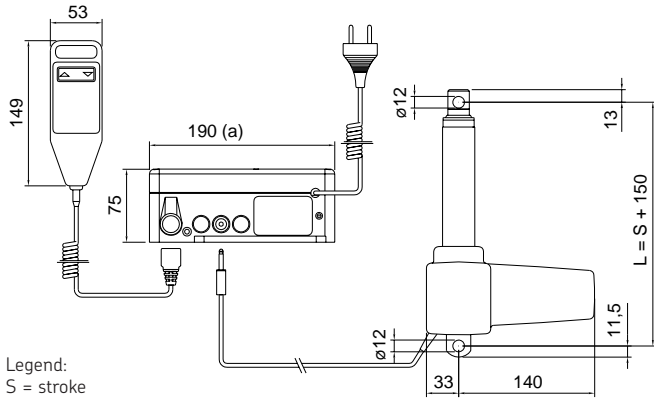

Legend:
 S = stroke
 L = retracted length
 (a) = depth 150

Technical data	Stroke (S)	Linear speed	Max dynamic load	Supply voltage
	mm	mm/s	N	VAC
EASY3-04	100 - 300	12 - 8	2000	230

Ordering key

CARE33E304 ×

Kit type

Stroke (S):

100 mm	100
200 mm	200
300 mm	300

Example: CARE33E304 × 100

Easy3-05

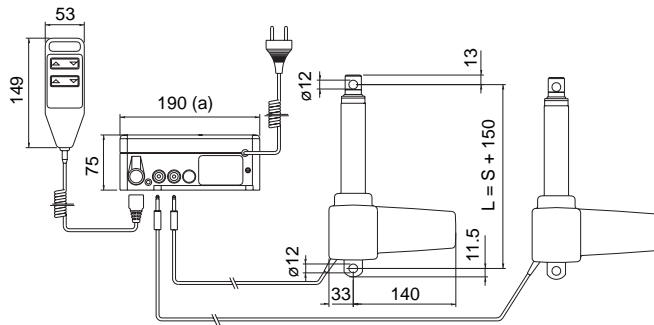

Legend:
 S = stroke
 L = retracted length
 (a) = depth 150

Technical data	Stroke (S)	Linear speed	Max dynamic load	Supply voltage
	mm	mm/s	N	VAC
EASY3-05	100 - 300	12 - 8	2000	230

Ordering key

CARE33E305 ×

Kit type

Stroke (S):

100 mm	100
200 mm	200
300 mm	300

Example: CARE33E305 × 200

4 Actuation systems

Easy3

Easy3-10

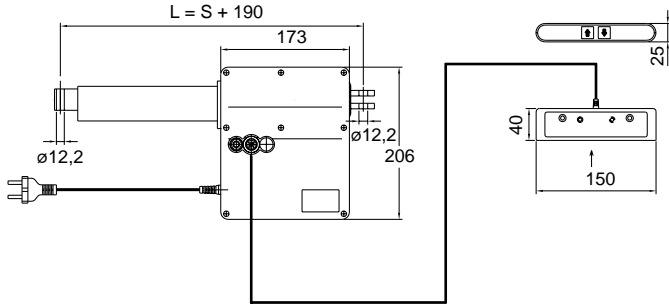

Legend:
S = stroke
L = retracted length

Technical data	Stroke (S)	Linear speed mm/s	Max dynamic load		Supply voltage
			push	pull	
	mm	mm/s	N		VAC
EASY3-10	100 - 200	7 - 4	7000	3000	230

Ordering key

EASY3-10 ×

Kit type

Stroke (S):

100 mm	100
150 mm	150
200 mm	200

Example: **EASY3-10** × **200**

Easy3-11

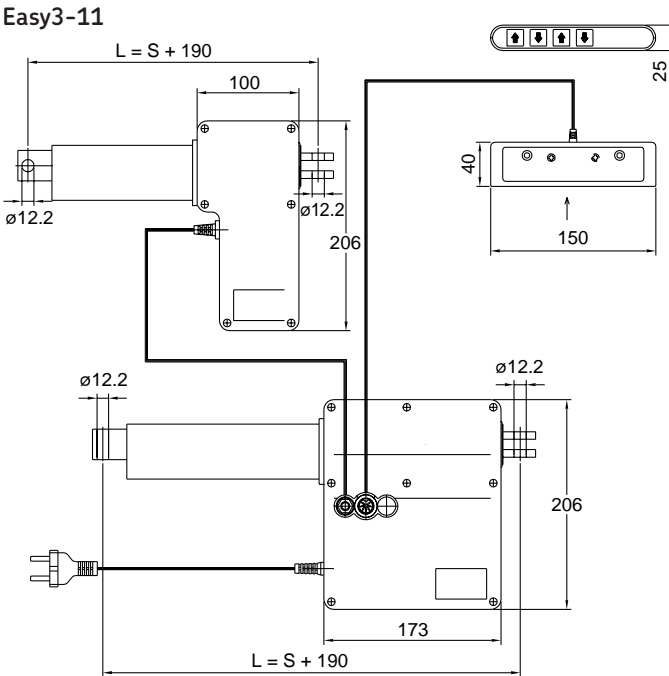

Legend:
S = stroke
L = retracted length

Technical data	Stroke (S)	Linear speed mm/s	Max dynamic load		Supply voltage
			push	pull	
	mm	mm/s	N		VAC
EASY3-11	100 - 200	7 - 4	7000	3000	230

Ordering key

EASY3-11 ×

Kit type

Stroke (S):

100 mm	100
150 mm	150
200 mm	200

Example: **EASY3-11** × **150**

Easy3-12

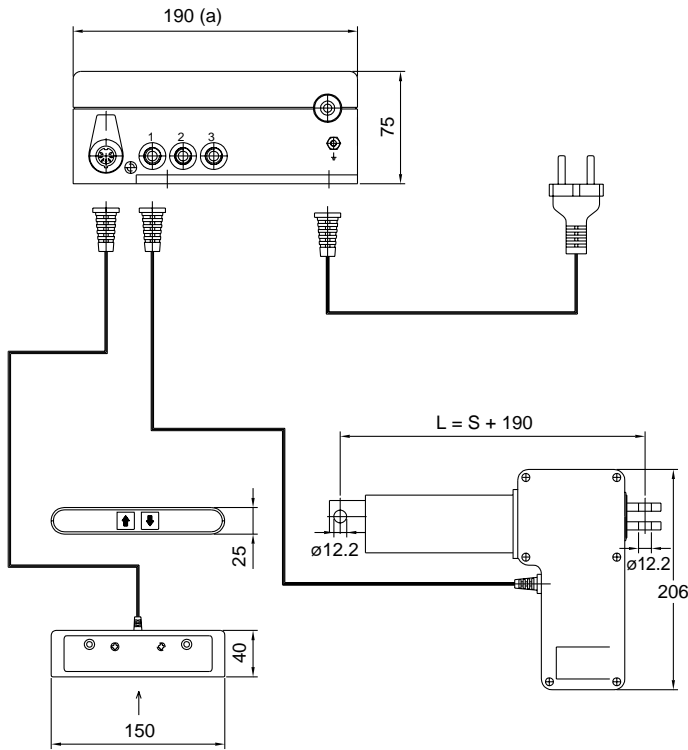

Legend:
 S = stroke
 L = retracted length
 (a) = depth 150

Technical data	Stroke (S)	Linear speed	Max dynamic load		Supply voltage
			push	pull	
	mm	mm/s	N		VAC
EASY3-12	100 - 200	7 - 4	7000	3000	230

Ordering key

EASY3-12 ×

Kit type

Stroke (S):

100 mm.....	100
150 mm.....	150
200 mm.....	200

Example: **EASY3-12** × **200**

Easy3-13

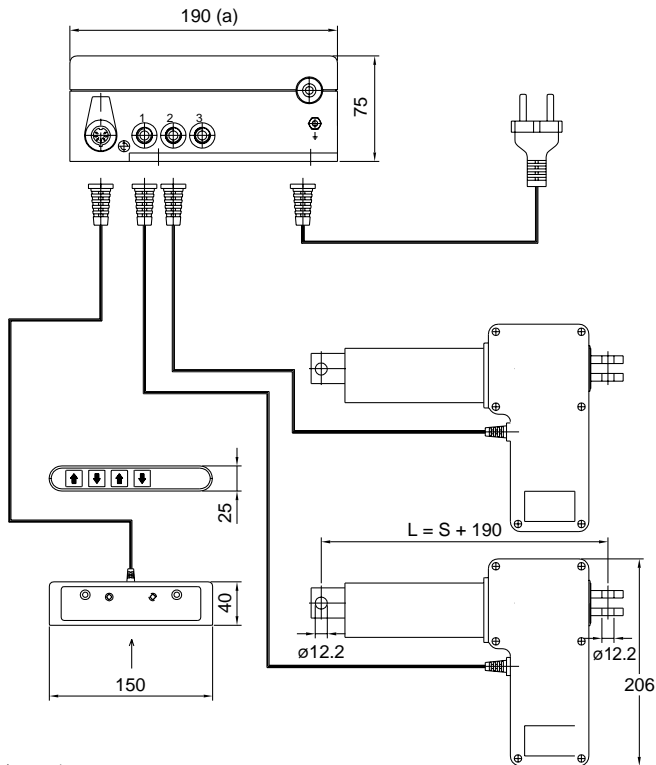

Legend:
 S = stroke
 L = retracted length
 (a) = depth 150

Technical data	Stroke (S)	Linear speed	Max dynamic load		Supply voltage
			push	pull	
	mm	mm/s	N		VAC
EASY3-13	100 - 200	7 - 4	7000	3000	230

Ordering key

EASY3-13 ×

Kit type

Stroke (S):

100 mm.....	100
150 mm.....	150
200 mm.....	200

Example: **EASY3-13** × **100**

4 Actuation systems

Guiding tube sets

Guiding tube sets FRE

Guiding tube sets (→ **figure 32**) are suitable to be built into the base construction of tables, chairs or other applications. It is an open system in which any kind of actuation systems (electric or hydraulic) can be built in.

The guiding tube sets are attractively designed, stable and can be used universally. They consist of high-quality, precise anodized aluminium profiles.

Benefits:

- Attractive design
- Stable
- Universal use

Figure 32

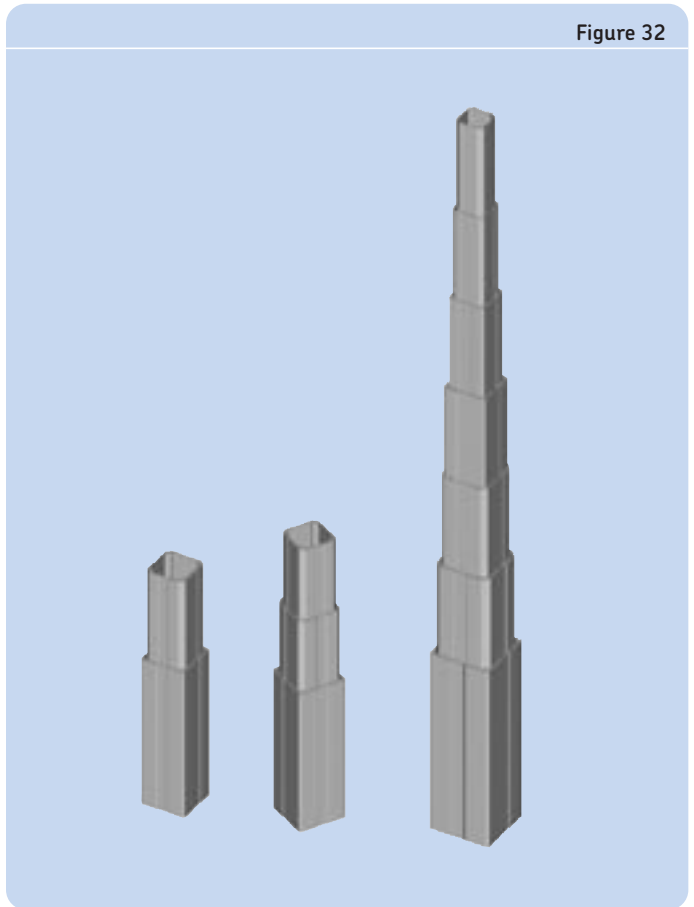

Type	Sections n.		Dimension profiles in mm							Retracted length in mm
	2	3	76×76	85×85	97×97	113×113	129×129	146×146	163×163	
FRE-A085	X									Stroke + 138
FRE-A113	X									Stroke + 148
FRE-A146	X									Stroke + 168
FRE-D097		X								Stroke + 38
FRE-D129		X								Stroke + 53
FRE-D163		X								Stroke + 53

Ordering key



Type

Combination:

2 sections tube-set / Largest tube size

85×85 mm	A 0 8 5
113×113 mm	A 1 1 3
146×146 mm	A 1 4 6
97×97 mm	B 0 9 7
129×129 mm	B 1 2 9
163×163 mm	B 1 6 3

3 sections tube-set / Largest tube size

97×97 mm	D 0 9 7
129×129 mm	D 1 2 9
163×163 mm	D 1 6 3
113×113 mm	E 1 1 3
146×146 mm	E 1 4 6

Colour:

Natural anodized	5
Black anodized	6

Options:

No option	0 0 0
Cover	M C M
Pull version	M C N
Pull version, with cover	2 E A

Stroke:

200 mm	20
300 mm	30
400 mm	40
500 mm	50
600 mm	60
700 mm	70

Customization:

None	000
------------	-----

Example: [FRE] - [A085] - [5] [MCM] [50] - [000]

4 Actuation systems

Spare parts

Spare parts

CAR 22 – Type codes for accessories and spare parts

Item code	Type Code
12 VDC-motor (flat motor)	D12B
24 VDC-motor (flat motor)	D24B
Limit switch for stroke = 50 mm	CAXB 22×50
Limit switch for stroke = 100 mm	CAXB 22×100
Limit switch for stroke = 150 mm	CAXB 22×150
Limit switch for stroke = 200 mm	CAXB 22×200
Limit switch for stroke = 300 mm	CAXB 22×300
Limit switch for stroke = 700 mm	CAXB 40×700
Proximity switch for CAXB	CAXB Proximity Switch
Front mounting attachments type rod-end	575-22
Front mounting attachments type clevis	576-22
Rear mounting attachments type single ear bracket	580-22
Rear mounting attachments type ball-joint bracket	581-22
Control unit (suitable for D24B motor)	CAED 5-24R
Handset matched for CAED	CAES 31C

CAR 32 – Type codes for accessories and spare parts

Item code	Type Code
12 VDC-motor (flat motor)	D12C
24 VDC-motor (flat motor)	D24C
24 VDC-motor (flat motor with brake)	D24CB
24 VDC-motor (flat motor with extended shaft)	D24CS
24 VDC-motor (flat motor with low speed)	D24CW
120 VAC-motor (cylindrical motor)	E110C
120 VAC-motor (cylindrical motor with brake)	E110CB
230 VAC-motor (cylindrical motor)	E220C
230 VAC-motor (cylindrical motor with brake)	E220CB
Capacitor value 25 µF (120 VAC)	Capacitor 25 µF
Capacitor value 6 µF (230 VAC)	Capacitor 6 µF
Limit switch for stroke = 50 mm	CAXB 32×50
Limit switch for stroke = 100 mm	CAXB 32×100
Limit switch for stroke = 200 mm	CAXB 32×200
Limit switch for stroke = 300 mm	CAXB 32×300
Limit switch for stroke = 500 mm	CAXB 32×500
Limit switch for stroke = 700 mm	CAXB 32×700
Proximity switch for CAXB	CAXB Proximity Switch
Front mounting attachments type rod-end	575-32
Front mounting attachments type clevis	576-32
Rear mounting attachments type single ear bracket	580-32
Rear mounting attachments type Universal joint	582-32
Control unit (suitable for C24C, D24C/CB/CS motors)	CAEP 10P-SL
Control unit (suitable for D24C/CB/CS motors)	CAEL 10-24R
Control unit (suitable for C24C, D24C/CB/CS motors)	CAEN 10R
Control unit (suitable for E110, E220 motors)	CAEV 110/220
Control unit (suitable for D24CW, C24CW motors)	CAED 5-24R
Control unit (suitable for D24C/CB/CS motors)	CAED 9-24R
Handset matched for CAEN, CAEP units	CAES 31B
Handset matched for CAED, CAEV, CAEL units	CAES 31C

CAR 40 – Type codes for accessories and spare parts

Item code	Type Code
24 VDC-motor (flat motor)	D24D
24 VDC-motor (flat motor with extended shaft)	D24DS
24 VDC-motor (flat motor with brake)	D24DB
120 VAC-motor (cylindrical motor)	E110D
120 VAC-motor (cylindrical motor with brake)	E110DB
230 VAC-motor (cylindrical motor)	E220D
230 VAC-motor (cylindrical motor with brake)	E220DB
Capacitor value 12 µF (230 VAC-motor)	Capacitor 12 µF
Limit switch for stroke = 100 mm	CAXB 40×100
Limit switch for stroke = 300 mm	CAXB 40×300
Limit switch for stroke = 500 mm	CAXB 40×500
Limit switch for stroke = 700 mm	CAXB 40×700
Proximity switch for CAXB	CAXB Proximity Switch
Front mounting attachments type rod-end	575-40
Front mounting attachments type clevis	576-40
Rear mounting attachments type single ear bracket	580-40
Rear mounting attachments type ball-joint bracket	581-40

CAP 32 – Type codes for accessories and spare parts

Item code	Type Code
12 VDC-motor (flat motor)	D12C
24 VDC-motor (flat motor)	D24C
24 VDC-motor (flat motor with brake)	D24CB
24 VDC-motor (flat motor with extended shaft)	D24CS
24 VDC-motor (flat motor with low speed)	D24CW
120 VAC-motor (cylindrical motor)	E110C
120 VAC-motor (cylindrical motor with brake)	E110CB
230 VAC-motor (cylindrical motor)	E220C
230 VAC-motor (cylindrical motor with brake)	E220CB
Capacitor value 25 µF (120 VAC)	Capacitor 25 µF
Capacitor value 6 µF (230 VAC)	Capacitor 6 µF
Limit switch for stroke = 50 mm	CAXB 32×50
Limit switch for stroke = 100 mm	CAXB 32×100
Limit switch for stroke = 150 mm	CAXB 32×150
Limit switch for stroke = 200 mm	CAXB 32×200
Limit switch for stroke = 300 mm	CAXB 32×300
Limit switch for stroke = 500 mm	CAXB 32×500
Limit switch for stroke = 700 mm	CAXB 32×700
Proximity switch for CAXB	CAXB Proximity Switch
Front mounting attachments type rod-end	575-32
Front mounting attachments type clevis	576-32
Rear mounting attachments type single ear bracket	580-32
Rear mounting attachments type Universal joint	582-32
Control unit (suitable for D24C/CB/CS/CW motors)	CAEP 8V

4 Actuation systems

Spare parts

CARN 32 – Type codes for accessories and spare parts

Item code	Type Code
Limit switch for stroke = 50 mm	CAXB 32×50
Limit switch for stroke = 100 mm	CAXB 32×100
Limit switch for stroke = 200 mm	CAXB 32×200
Limit switch for stroke = 300 mm	CAXB 32×300
Limit switch for stroke = 500 mm	CAXB 32×500
Limit switch for stroke = 700 mm	CAXB 32×700
Proximity switch for CAXB	CAXB Proximity Switch
Front mounting attachments type rod-end	575-32
Front mounting attachments type clevis	576-32
Rear mounting attachments type single ear bracket	580-32
Rear mounting attachments type Universal joint	582-32

CCBR 32 – Type codes for accessories and spare parts

Item code	Type Code
Limit switch for stroke = 50 mm	CAXB 32×50
Limit switch for stroke = 100 mm	CAXB 32×100
Limit switch for stroke = 200 mm	CAXB 32×200
Limit switch for stroke = 300 mm	CAXB 32×300
Limit switch for stroke = 500 mm	CAXB 32×500
Limit switch for stroke = 700 mm	CAXB 32×700
Proximity switch for CAXB	CAXB Proximity Switch
Front mounting attachments type rod-end	575-32
Front mounting attachments type clevis	576-32

CAT 33 – Type codes for accessories and spare parts

Item code	Type Code
12 VDC-motor (cylindrical motor)	C12C
12 VDC-motor (flat motor)	D12C
24 VDC-motor (cylindrical motor)	C24C
24 VDC-motor (cylindrical with low speed)	C24CW
24 VDC-motor (flat motor)	D24C
24 VDC-motor (flat motor with brake)	D24CB
24 VDC-motor (flat motor with extended shaft)	D24CS
24 VDC-motor (flat motor with low speed)	D24CW
120 VAC-motor (cylindrical motor)	E110C
120 VAC-motor (cylindrical motor with brake)	E110CB
230 VAC-motor (cylindrical motor)	E220C
230 VAC-motor (cylindrical motor with brake)	E220CB
400 VAC-motor (cylindrical motor)	E380C
Capacitor value 25 µF (120 VAC)	Capacitor 25 µF
Capacitor value 6 µF (230 VAC)	Capacitor 6 µF
Limit switch for any stroke	CAXC33
Front mounting attachments type rod-end	575-32
Front mounting attachments type clevis	576-32

Continued

CAT 33 – Type codes for accessories and spare parts

(continued)

Item code	Type Code
Rear mounting attachments type single ear bracket	580-32
Rear mounting attachments type Universal joint	582-32
Control unit (suitable for C24C, D24C/CB/CS motors)	CAEP 10P-SL
Control unit (suitable for D24C/CB/CS motors)	CAEL 10-24R
Control unit (suitable for C24C, D24C/CB/CS motors)	CAEN 10R
Control unit (suitable for E110, E220 motors)	CAEV 110/220
Control unit (suitable for D24CW, C24CW motor)	CAED 5-24R
Control unit (suitable for D24C/CB/CS motors)	CAED 9-24R
Handset matched for CAEN, CAEP units	CAES 31B
Handset matched for CAED, CAEV, CAEL units	CAES 31C

4

CAT 33H – Type codes for accessories and spare parts

Item code	Type Code
12 VDC-motor (cylindrical motor)	C12C
12 VDC-motor (flat motor)	D12C
24 VDC-motor (cylindrical motor)	C24C
24 VDC-motor (cylindrical with low speed)	C24CW
24 VDC-motor (flat motor)	D24C
24 VDC-motor (flat motor with brake)	D24CB
24 VDC-motor (flat motor with extended shaft)	D24CS
24 VDC-motor (flat motor with low speed)	D24CW
110 V AC-motor (cylindrical motor)	E110C
230 V AC-motor (cylindrical motor)	E220C
230 V AC-motor (cylindrical motor with brake)	E220CB
400 V AC-motor (cylindrical motor)	E380C
Capacitor value 6 μ F (230 VAC)	Capacitor 6 μ F
Limit switch for any stroke	CAXC33
Front mounting attachments type rod-end	575-32
Front mounting attachments type clevis	576-32
Rear mounting attachments type single ear bracket	580-32
Rear mounting attachments type Universal joint	582-32
Control unit (suitable for C24C, D24C/CB/CS motors)	CAEP 10P-SL
Control unit (suitable for D24C/CB/CS motors)	CAEL 10-24R
Control unit (suitable for C24C, D24C/CB/CS motors)	CAEN 10R
Control unit (suitable for E110, E220 motors)	CAEV 110/220
Control unit (suitable for D24CW, C24CW motor)	CAED 5-24R
Control unit (suitable for D24C/CB/CS motors)	CAED 9-24R
Handset matched for CAEN, CAEP units	CAES 31B
Handset matched for CAED, CAEV, CAEL units	CAES 31C

4 Actuation systems

Spare parts – Attachments / Limit switches

CAT 32B – Type codes for accessories and spare parts

Item code	Type Code
12 VDC-motor (cylindrical motor)	C12C
12 VDC-motor (flat motor)	D12C
24 VDC-motor (cylindrical motor)	C24C
24 VDC-motor (cylindrical with low speed)	C24CW
24 VDC-motor (flat motor)	D24C
24 V DC-motor (flat motor with brake)	D24CB
24 VDC-motor (flat motor with extended shaft)	D24CS
24 VDC-motor (flat motor with low speed)	D24CW
120 VAC-motor (cylindrical motor)	E110C
120 VAC-motor (cylindrical motor with brake)	E110CB
230 VAC-motor (cylindrical motor)	E220C
230 VAC-motor (cylindrical motor with brake)	E220CB
400 VAC-motor (cylindrical motor)	E380C
Capacitor value 25 µF (120 VAC)	Capacitor 25 µF
Capacitor value 6 µF (230 VAC)	Capacitor 6 µF
Limit switch for stroke = 50 mm	CAXB 32×50
Limit switch for stroke = 100 mm	CAXB 32×100
Limit switch for stroke = 200 mm	CAXB 32×200
Limit switch for stroke = 300mm	CAXB 32×300
Limit switch for stroke =400 mm	CAXB 32×400
Limit switch for stroke = 500mm	CAXB 32×500
Limit switch for stroke = 700mm	CAXB 32×700
Proximity switch for CAXB	CAXB Proximity Switch
Front mounting attachments type rod-end	575-32
Front mounting attachments type clevis	576-32
Rear mounting attachments type single ear bracket	580-32
Rear mounting attachments type Universal joint	582-32
Control unit (suitable for C24C, D24C/CB/CS motors)	CAEP 10P-SL
Control unit (suitable for D24C/CB/CS motors)	CAEL 10-24R
Control unit (suitable for C24C, D24C/CB/CS motors)	CAEN 10R
Control unit (suitable for E110, E220 motors)	CAEV 110/220
Control unit (suitable for D24CW, C24CW motor)	CAED 5-24R
Control unit (suitable for D24C/CB/CS motors)	CAED 9-24R
Handset matched for CAEN, CAEP units	CAES 31B
Handset matched for CAED, CAEV, CAEL units	CAES 31C

CAP 43 – Type codes for accessories and spare parts

Item code	Type Code
24 VDC-motor (cylindrical motor)	C24C
24 VDC-motor (cylindrical with low speed)	C24CW
24 VDC-motor (flat motor)	D24C
24 VDC-motor (flat motor with low speed)	D24CW
Front mounting attachments type rod-end	575-32
Front mounting attachments type clevis	576-32
Rear mounting attachments type single ear bracket	580-32
Rear mounting attachments type Universal joint	582-32
Control unit (suitable for D24C motors)	CAED-ANR

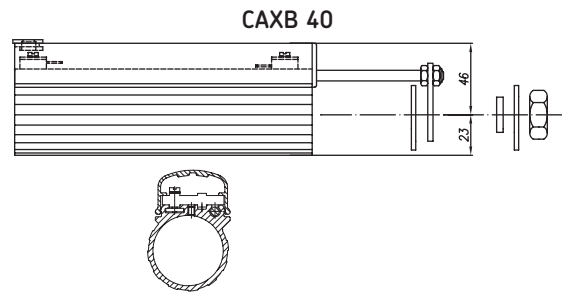
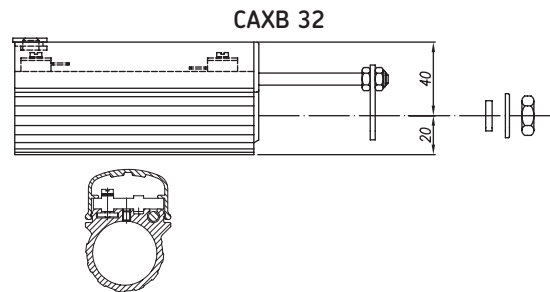
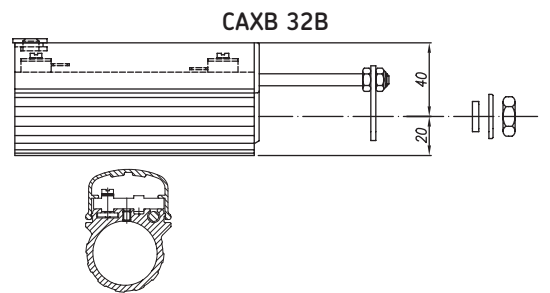
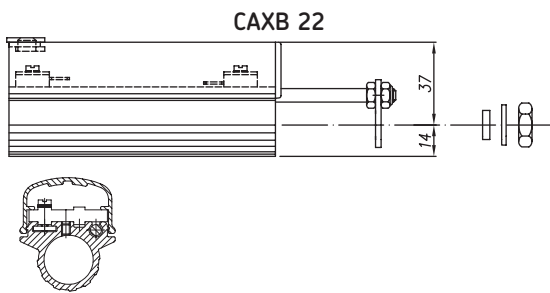
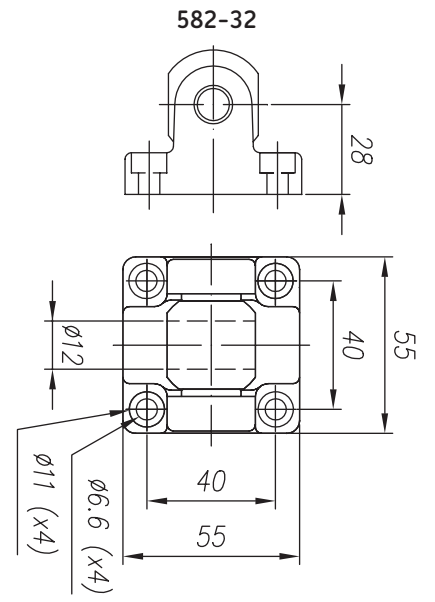
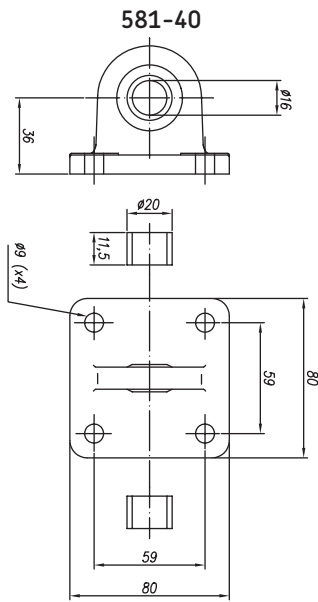
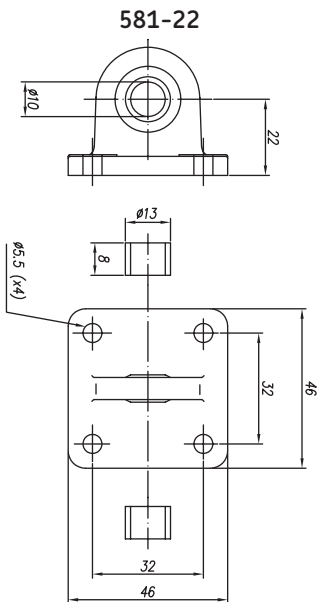
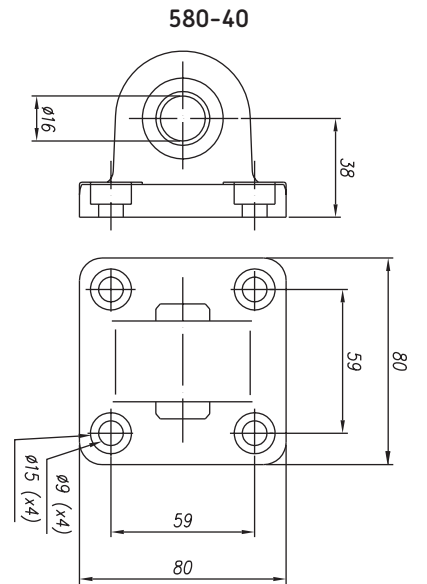
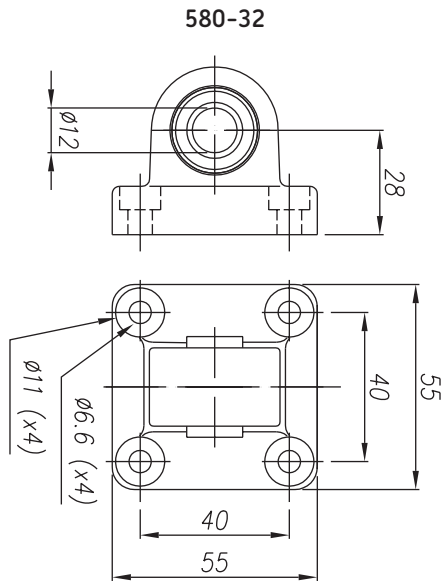
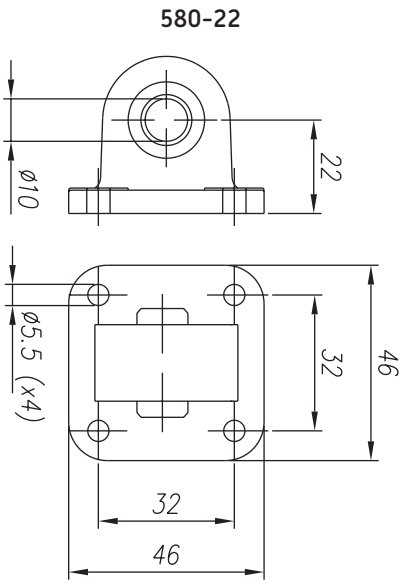

4 Actuation systems
Spare parts - Motors

575-22

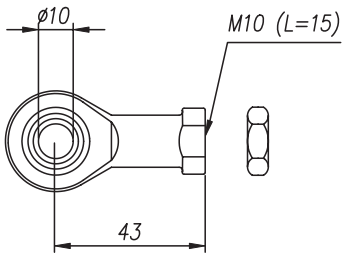

575-32

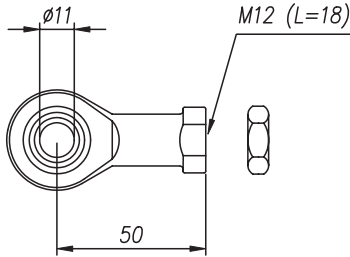

575-40

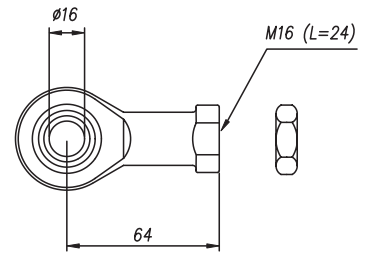

576-22

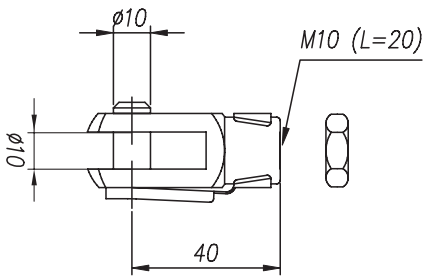

576-32

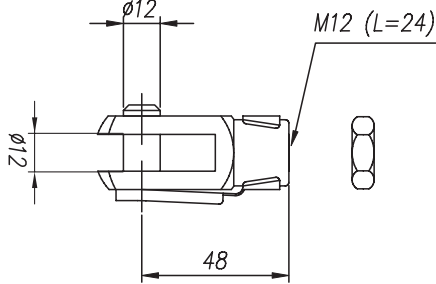

576-40

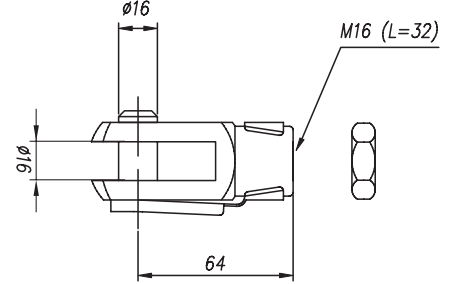

CAXC 33

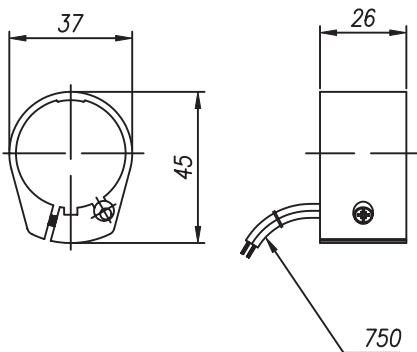

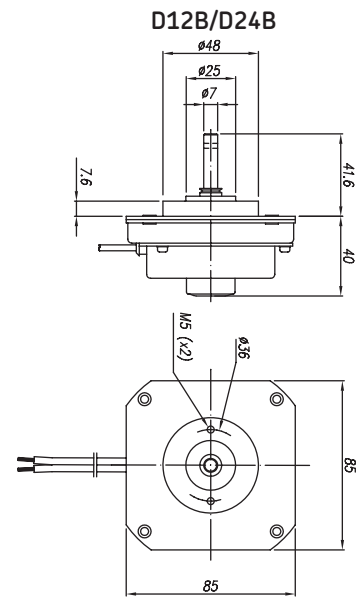
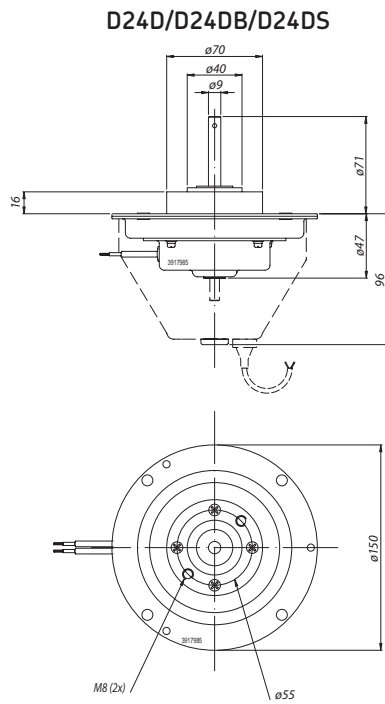
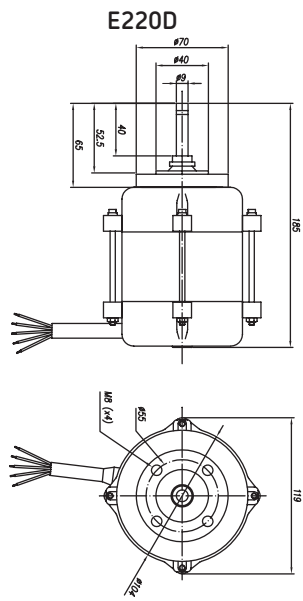
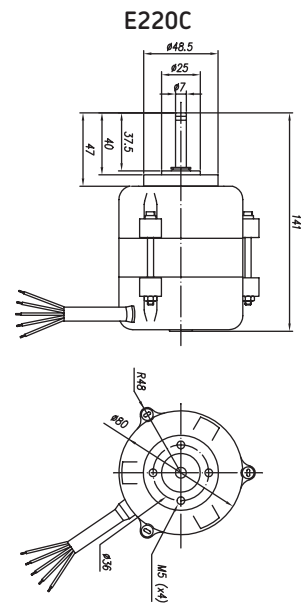
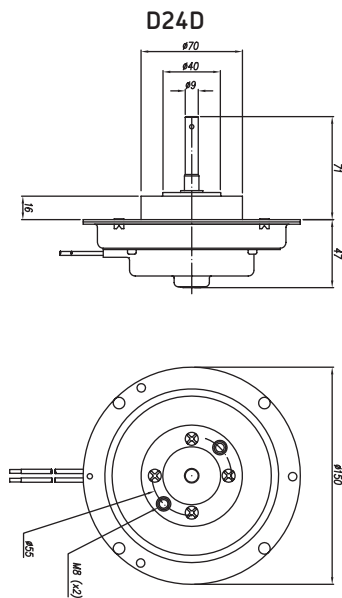
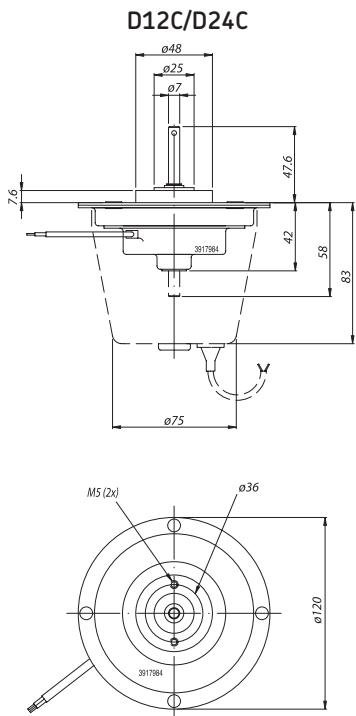

Glossary and definitions

Anti-pinching (electric)

A safety option that is available on certain SKF actuators. It shuts-off the motor when an external force is applied in the opposite direction to the direction of travel.

Anti-pinching (mechanical)

This safety mechanism allows the actuator to push but not pull or pull but not push. This feature is designed to prevent injury to persons due to being trapped by the force of the actuator.

Back up nut

A nut, usually metal, of greater anti-shear strength than the drive nut and which only makes contact with the threads of the spindle when the threads of the drive nut fail.

Emergency lowering

The emergency lowering safety feature enables the actuator to be lowered in the event of a power failure or malfunction. This option is used in most medical & care applications.

Encoder

A rotary or linear sensor device that, when connected to a control unit, can be used to determine the position of an electric linear actuator.

First failure safety

First Failure Safety is a control system utilising redundant micro processors in which one processor monitors the functions of the other and shuts down the system if a malfunction in the microprocessor occurs.

Hall sensor

A sensor whose output changes based on changes in magnetic flux. Typically used for RPM, position, or current measurement.

IP protection

This standard describes a system for classifying the degrees of protection required by the enclosures of electrical equipment. Developed by the European Committee for Electrotechnical Standardization (CENELEC), these standards are designed to numerically rate

an electrical product based on the level of protection its enclosure provides.

Limit switches

A switch used to limit motion or travel in a particular direction. Mechanical devices that when activated open or close an electrical contact. When the contact is closed voltage will flow through the switch, when open no voltage will flow through the switch. Limit switches come in various physical sizes and configurations and can be mounted internally or externally.

Potentiometer

The potentiometer is a displacement transducer. It incorporates the sensor and transducer function into one. A typical potentiometer consists of a uniform coil of wire of an element of high resistance such as carbon, platinum or conductive plastic. This uniform coil makes up the resistive element of the potentiometer whose resistance is proportional to its length.

Pull force

The maximum retracting force that an electric linear actuator can produce in Newton (N). Some SKF actuators do not produce equal push and pull forces and others do not permit pull force at all.

Push force

The maximum extending force that an electric linear actuator can produce in Newton (N). Some SKF actuators do not produce equal push and pull forces and others do not permit pull force at all.

Stroke length

Describes the length in millimetres that an electric linear actuator will extend or retract. Most standard products are available in increments of 50 mm or 100 mm. Customer specific lengths are available, minimum order quantities apply.

Thermal protection

Protects drives and control units from overheating. A device that signals when an electrical assembly becomes too hot. The signal usually causes the shut-off of the electrical device.

Linear speed

Linear speed is the term used when we talk about the distance, in millimetres, the tube in an actuator moves linearly over a given period of time (mm/s.), moving a load from its starting point to a new position. The speed can vary in different ways, depending, for example, on the motor employed. Actuators with direct current (DC) motors have a speed variation directly proportional to the load on the device. That is to say, the larger the load, the lower the speed and vice versa. Actuators with alternating current (AC) motors move at a constant speed, which is not affected by the load on the actuator. Other factors affecting speed include ambient temperature and how well or poorly the actuator is integrated within an application. An actuator integrated in such a way that it is subject to uneven loads wears abnormally, which results in increased friction forces and decreased speed.

Dynamic load

Maximal dynamic load refers to the maximum total weight or mass the actuator can move. Often, the decisive factor for maximal load is the size of the motor and the gearing employed. When an actuator is subject to loads exceeding the maximum stated value, the device simply stops. Certain actuator types have an integral mechanical safety device similar to a slip-clutch, designed to protect the motor and gears from damage. Electrical limit switches are another alternative. These protect the actuator from damage caused by excessive electrical current. All such safety devices are part of an operating system and it is important to be aware of them when using SKF actuators with other operating equipment.

Static load (value not available in this brochure)

Maximal static load refers to the weight or mass that an actuator can be subjected to when standing still without causing permanent damage or causing the actuator to start "going backwards". Subjecting an actuator to loads in excess of stated values can risk permanent deformation to some part of the actuator. N.B. Remember that in

many applications and installations, it is not the weight applied directly but rather the load caused by leverage or similar forces acting on the actuator that are the decisive factor. An actuator is strongest in its shortest position and weakest in its outermost, most extended position.

DC-motors

An electric motor powered by direct current electricity (12-48 VDC) that can be run on batteries. These motors are suitable for use in situations where you want to be able to move the product easily and do not want a cable in the way. The speed of a DC-motor is directly proportional to the load, i.e., the motor moves slowly under maximum load and fastest when run with no load at all. In many applications the actuator works both pushing and pulling, which means that the load works to “assist” in one direction and “resist” in the other. Consequently, considerable speed variations can arise.

AC-motors

An electric motor powered by alternating current electricity (120-400 VAC), which requires an electrician for its connection. Start-up properties can be improved with various accessories and different methods of connection. There are many standard accessories available for control and regulation of an AC-motor. An AC-motor is best suited to non-mobile products, i.e., fixed installations, often in industrial environments. An actuator with an AC-motor is less sensitive to load variations and maintains virtually the same speed regardless of load. The normal working temperature for this type of motor is 70°C. An AC-motor has few moving parts that wear and is consequently rugged and has a long life span.

Retracted length

“Retracted length” is an expression for the shortest distance between the two fixed points on an actuator when the actuator is in its innermost position. The dimensions given reflect a measurement from the centre of the mounting holes, which means that the actuator requires a few millimetres beyond the given “retracted length” in order to fit. Remember that very few actuators are symmetrical. Thus it is important to note other dimensions as well for optimum fit and integration of the actuator. An actuator should always be mounted, insofar as is possible, so that it works linearly over its entire working range.

Duty factors

A technical term expressing how long a motor can handle non-stop operation before it becomes overheated or otherwise damaged. It should be noted that “Duty Factor”, whether expressed as a percentage or time, varies depending on the working load for the motor. The duty-cycle tells how often an actuator will be in operation within an application and the amount of time between operations. Because of the power lost due to inefficiency dissipated as heat, the actuator component with the lowest allowable temperature – usually the motor – sets the duty-cycle limit for the complete actuator. Although, there is some heat loss from friction in the gearbox and by ball-screw and acme-screw drive systems. An example of a duty cycle calculation: assume an actuator runs for 10 seconds cumulatively, up and down, and then does not run for another 40 seconds. The duty cycle is $10/(40+10)$, or 20%.

Temperature

Ambient work site temperature can be highly significant when making a choice

between different actuators. Extreme heat or cold can reduce the working capacity of the equipment. If the equipment is used in temperatures as low as about -20°C, for instance, the lubricant can harden and impair the efficiency of the motor. If the temperatures climb up towards 50°C, for instance, the grease can melt so that it drains away from the screw system, resulting in reduced or eliminated lubricant effect and increasing the risk of overheating in the motor.

Power consumption

An expression of how much electricity the motor uses when working. For DC motors the power consumption is directly proportional to the load, and for AC motors the power consumption is constant. With alternating current, power consumption is low, so simple cabling and other inexpensive accessories suffice. Installation is easy and the components are readily available. With battery operation, it is often adequate to use a small, lightweight battery that does not require much space and is relatively inexpensive.

Supply voltage

Supply voltage is a measure of the voltage supplying a system, regardless of whether it employs AC or DC-motors.

Properties of the sliding screw

(→ figure 33)

Sliding screws are manufactured from rolled steel and the nut is made of plastic. This is a relatively cost effective design with favourable properties: plastic and metal work well together without binding. Also, actuators incorporating sliding screws usually offer a price advantage over those built around other types of screws. The sliding screw works very quietly, which means that it is well suited for office environments, hospitals, etc. Another significant advantage is the high friction coefficient in the sliding screw. This design is particularly well suited for actuators used in applications where they should be self locking, i.e., will not begin “moving backwards” under the weight of the load. For instance, when using the actuator to drive vertically adjustable tables, a sliding screw design allows you to put heavy loads on the surface of the table without changing its vertical position. In short, this means that no additional locking mechanism or brake will be necessary

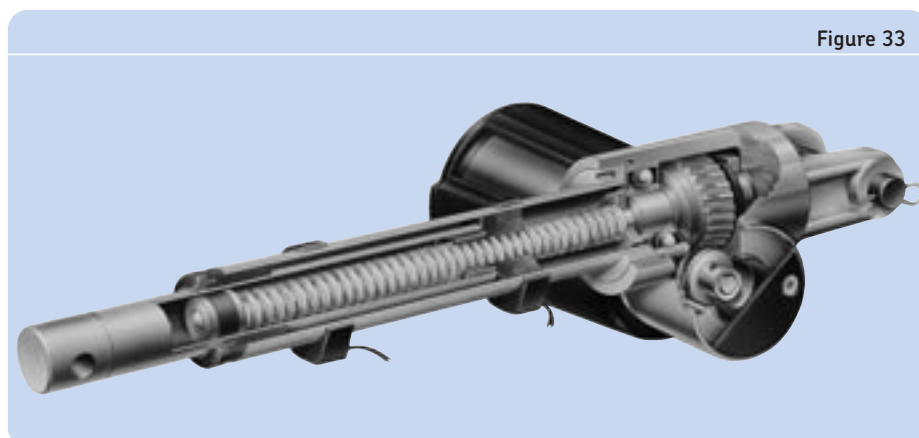

Figure 33

4 Actuation systems

Glossary and definitions

to keep the actuator in position when it is not in operation (however, e.g., in extreme vibrating application types additional arrangements may be needed to prevent back driving).

Properties of ball screws (→ figure 34)

The ball screws incorporated in SKF actuators are manufactured entirely of steel and equipped with a row of bearings located in a closed system between the nut and screw. The design yields extremely low friction coefficients between the nut and the screw, because of the rolling contact between the balls, the nut and raceway (similar to ball bearings). Wear is significantly reduced compared with a sliding screw, which results in a life span 10 times longer for a ball screw under the same working conditions. The durability of the screw also means that it tolerates extreme loads as well as high duty cycles. Thanks to its low frictional resistance, the ball screw can maintain a very low operating temperature. As a consequence, the ball screw is particularly well suited in situations where it is required to operate over long periods at high speeds. High efficiency is one of the main characteristics of ball screws. Thanks to this high efficiency, it is possible to use a motor half the size compared to a sliding screw design. This means that, as a user, you obtain a more economical solution. An actuator based on a ball screw has minimal play, and consequently its precision is

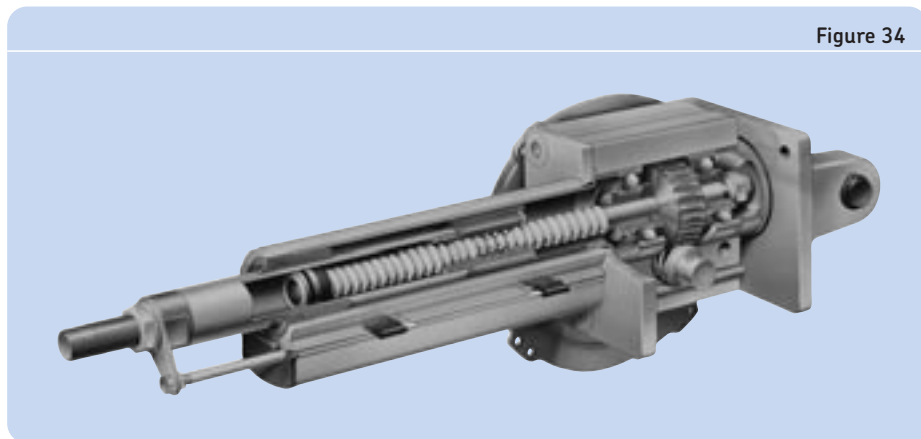

Figure 34

significantly higher in applications where positioning and repetitive precision are important.

Self-locking

This property of the actuator means that it will not continue to move under the weight of the load after it has been switched off. The self-locking ability depends on the total efficiency of the actuator. If an actuator is not self locking the function can be obtained by using a brake. On DC-motors, the motor has to be short circuited. Self-locking load can under certain circumstances not be completely ensured on all actuator models due to the type of application being run (e.g., high vibration levels)!

Alignment

It is important that the product is mounted properly from the beginning. If the actuator is improperly installed, normal operation may cause poor performance. Remember, therefore, to carefully follow the accompanying mounting instructions. Naturally, you can turn to your supplier or distributor whenever you have questions about our products.

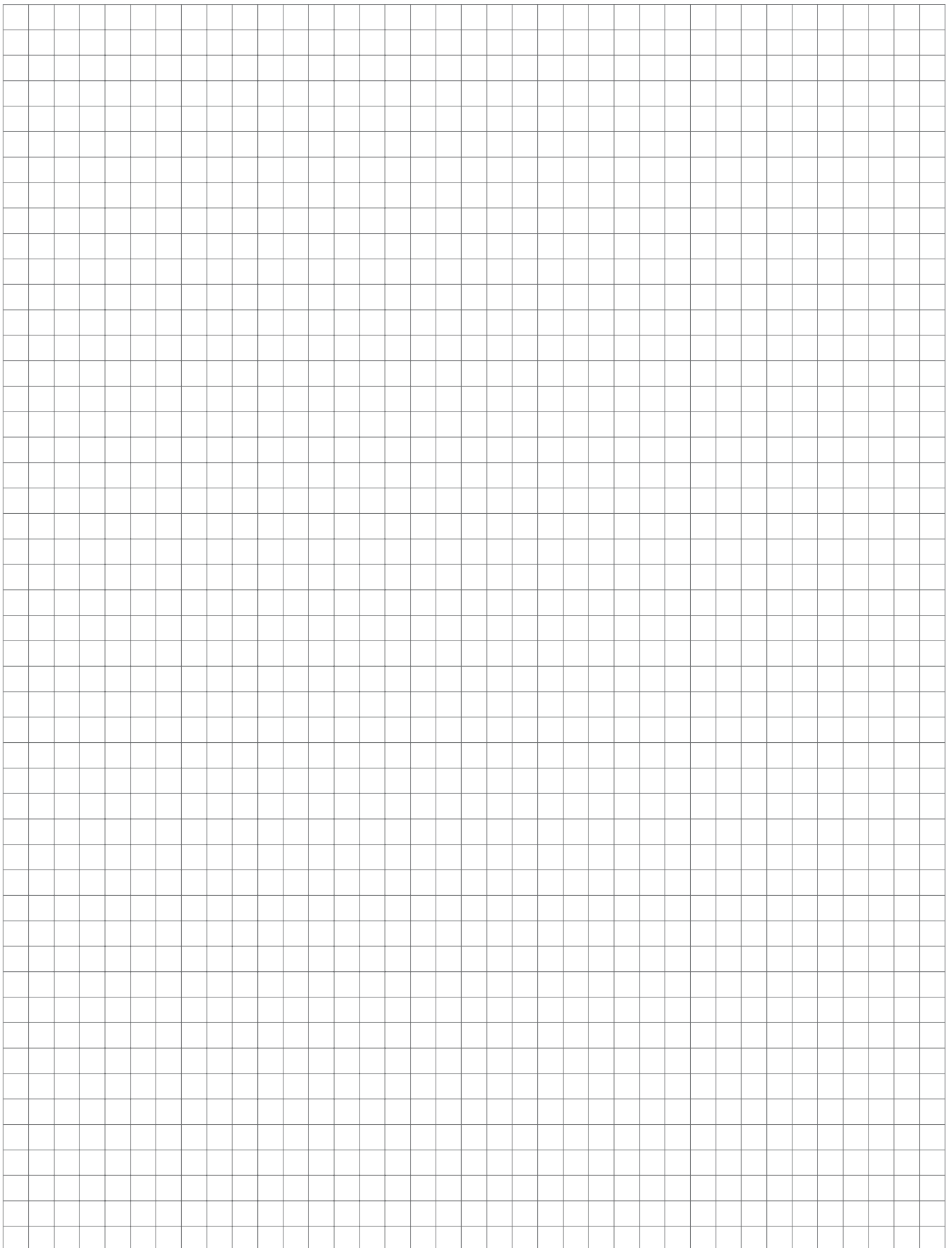



The highest power lies beneath the smallest things.



An ant can lift up to thirty times and transport up to fifty times its own weight. It's the power of such small things that has inspired SKF to create solutions with reduced dimensions yet endowed with great potential for your applications. Behind compactness and decreased weight lies high performance which will lead to greater precision and efficiency, while reducing cycle times to a minimum. Miniature profile rail guides, miniature linear ball bearings, miniature ball screws, miniature slides - small units that can be placed almost anywhere, but always of the highest quality which you might expect from SKF.

Linear motion from SKF
www.linearmotion.skf.com



Positioning systems

General

Positioning systems are compact and economic complete solutions. The assortment ranges from compact slides without drives through to highly dynamic, multi-axis systems with linear motor drive. SKF offers the following positioning systems:

- Miniature slides (→ **figure 1**);
- Standard slides (→ **figure 2**);
- Dovetail slides (→ **figure 3**);
- Compact cross tables (→ **figure 4**);
- Precision slides without drive (→ **figure 5**);
- Precision slides with drive (→ **figure 6**);
- Linear ball bearing slides (→ **figure 7**);
- Linear axes, type Pico (→ **figure 8**);
- Profile rail slides (→ **figure 9**);
- Complete systems (→ **figure 10**);

LZM miniature slides

With the new LZM miniature slide SKF offers the ideal solution for linear motion applications for short strokes and compact boundary dimensions.

The use of miniature slides has increased in medical applications,

measurement technologies, pneumatics, micro mechanics and micro electronics assembly, semiconductor manufacturing and fibre optics. The different miniature slide components meet the highest precision standards; LZM miniature slides feature high running accuracy and smooth motion.

The LZM are manufactured with all stainless steel components. Optimised hardness enables long endurance life and high performance within compact boundary dimensions.

The miniature slides have been designed to ensure high system stiffness and precision guidance. Running accuracies of 2 μm over a stroke of 100 mm are attainable depending on the particular application. Ease of installation is another advantage of the LZM miniature slides. Unlike cross roller systems using 4 rails and cages to be assembled on the production floor, the LZM slide provides a complete slide that can simply be bolted into place without the use of precision devices to set preload.

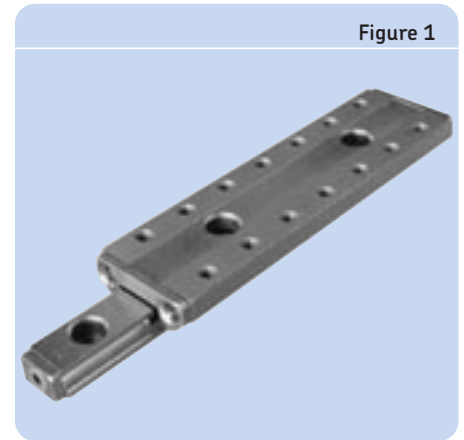

Figure 1

Every application provides new challenges for the modern designer. SKF will modify existing designs to meet your specific technical requirements.

Advantages for LZM miniature slides:

- Compact design
- High carrying capacity
- Very good running accuracy
- Smooth running
- High stiffness
- Easy assembly

Dimensions see table on **page 313**

Operating precision (→ Table 1)

Comparison of the different positioning components and systems.

Operating precision (μm)	Guiding systems	Driving systems	Actuation systems	Positioning systems
0.1 – 1	Precision rail guides	Roller screws		
1 – 10	Profile rail guides	Ball screws		
10 – 100	Standard slides	Linear motors		
100 – 1000	Cam roller guides		Electro-mechanical actuators	Standard drives or linear motors with all guiding systems

5 Positioning systems

General

GCL standard slides

Slide top and base of steel. The slides are provided with standard patterns of mounting holes. The slide top carries tapped holes, the base plate counterbored holes for cylindrical screws to DIN 912. The slides are fitted with SKF precision rail guides with crossed roller units. Internal stops serve as stroke limit.

Dimensions see table on **page 316**

GCLA standard slides

Slide top and base of black anodised aluminium. In other respects, the design corresponds to that of the GCL slides except that they are lower in height.

Dimensions see table on **page 318**

RM standard slides

Especially small design. Slide top of steel, guidance via SKF precision rails with double-sided centre rail and crossed roller units. Internal stops serve as stroke limits.

Dimensions see table on **page 320**

Figure 2

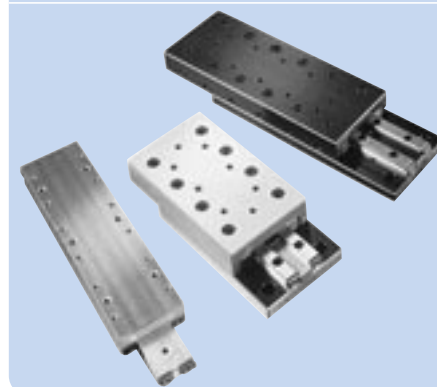
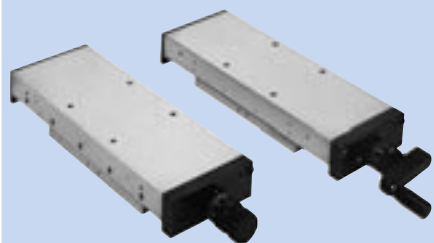

Figure 3



SSM and SSK dovetail slides

Slide top and base of grey cast iron. The slides are provided with standard patterns of mounting holes. Top and base plate both carry tapped holes. The slides have a lead screw drive. The SSM design has a micrometer knurl with vernier ring, while the SSK design is fitted with a hand crank. Both designs are fitted with a lateral locking device.

Dimensions see table on **page 322**

Figure 4

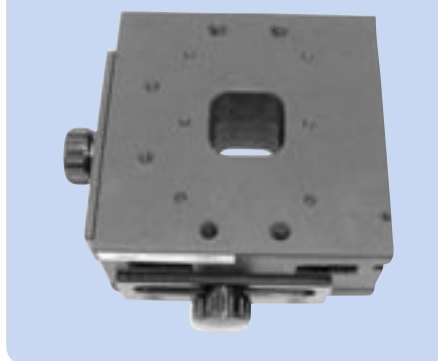

TO and TS compact cross tables

Table top, centre and base of black anodised aluminium with central viewing hole. The slides are fitted with SKF precision rail guides incorporating crossed roller units. The TO design does not have a drive but is provided with one lateral locking device per axis. The TS design has a micrometer attachment that is spring-loaded in one direction. In addition one lateral locking device is fitted per axis.

Dimensions see table on **page 325**

Figure 5

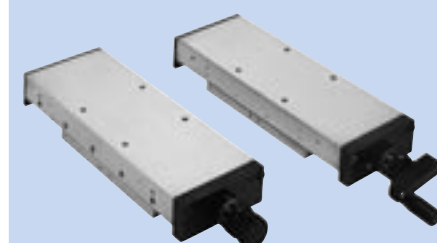

RSM and RSK precision slides

Slide top and base of grey cast iron. The slides are provided with standard patterns of mounting holes. The slide top carries tapped holes, the base plate counterbored holes for cylindrical screws to DIN 912. They are fitted with SKF precision rail guides incorporating crossed roller units. The slides have a lead screw drive. The RSM design has a micrometer knurl with a vernier ring, while the RSK design is fitted with a hand crank.

Dimensions see table on **page 326**

Figure 6

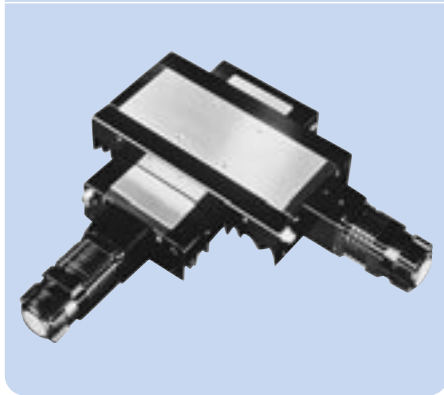

RSS precision slides

Slide top and base of grey cast iron. The slides are provided with standard patterns of mounting holes. The slide top carries tapped holes, the base plate counterbored holes for cylindrical screws to DIN 912. The slides are fitted with SKF precision rail guides incorporating crossed roller units. They are driven by pre-loaded planetary roller screws attached on one side. The slides are covered by bellows. Limit switches can be fitted under the lateral plate cover angles. The individual slides can be assembled in various ways to form cross tables or multi-axis systems.

Principal dimensions see table on [page 328](#)

Figure 7



LZBB and LZAB linear ball bearing slides

The slides are fitted with SKF linear ball bearings of ISO series 3. They are driven via SKF rolled thread ball screws attached on both sides. The slides are protected by bellows. The LZBB design has a closed housing. Shafts are attached on both sides in shaft blocks which also incorporate the bolt holes for attaching the slide. The LZAB design has an open housing. Shafts are attached over the entire length by shaft supports to prevent shaft deflection with large strokes or high loads. The slide is attached via the bolt holes in the two shaft supports.

Principal dimensions see table on [page 332](#)

Figure 8

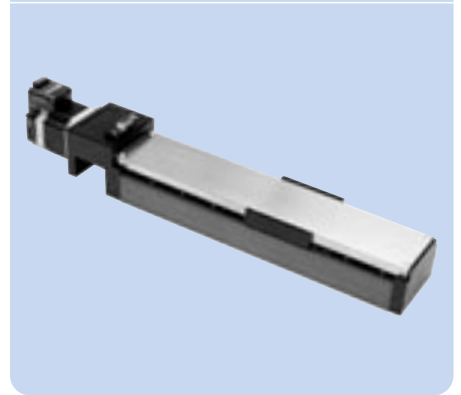

LTP linear axes, type PICO

Linear axes are high dynamic units with a high load carrying capacity and stiffness. The slide material is eloxated aluminium to optimize the weight. The running accuracy in a μm range and the preloaded ballscrews lead to a precise positioning, required in pick&place machines, medical applications or precise handling units. The axes are available in 2 widths, with stainless steel cover, integrated endswitches, connected with a Sub-D connector.

Principal dimensions see table on [page 337](#)

5

Figure 9

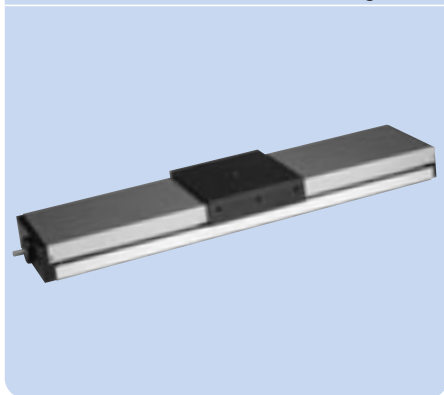

LTB profile rail slides

SKF profile rail slides are state-of-the-art systems that offer high load-carrying capacity and accuracy. They are available in five sizes: 110 – 170 – 235 – 320 – 400 with two drives: ball screws – linear motors with three covers: without cover – with bellows – with steel cover

Principal dimensions see table on [page 342](#)

Figure 10

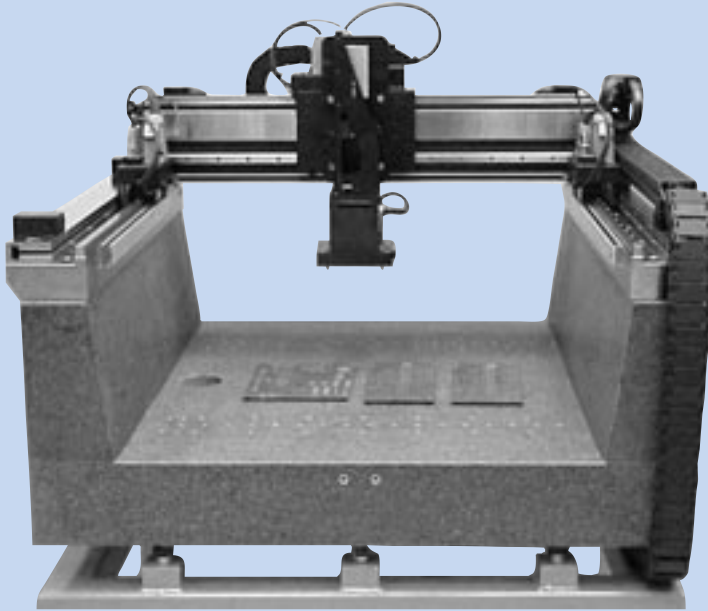

Complete systems

On special demand, SKF designs and manufactures complete systems, either from SKF standard components or special solutions that are exactly tailored to the respective application.

Please demand the responsible SKF application engineer.

The different specifications are given in **Table 2**.

Figure 11

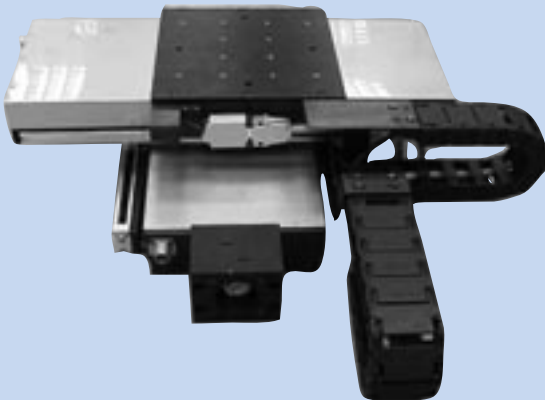

NB:

In addition to this catalogue we have all product brochures available as pdf document on the internet.

www.linearmotion.skf.com/doc

Table 2

Type	Precision	Load-carrying capacity	Dynamic capabilities	Speed
Miniature slides				
Standard slides				
Dovetail slides				
Compact cross tables				
Precision slides without drive				
Precision slides with drive				
Linear ball bearing slides				
Linear axes				
Profile rail slides				
Complete systems				

5 Positioning systems

Miniature slides

Miniature slides

LZM

Ordering key

	LZM	HS	<input type="text"/>	×	<input type="text"/>
Type					
Carriage: Standard					HS
Size: 17 mm.....					7
20 mm.....					9
27 mm.....					12
32 mm.....					15
Length [mm]: See table					

Example: **LZM** **HS** **15** × **165**

LZM

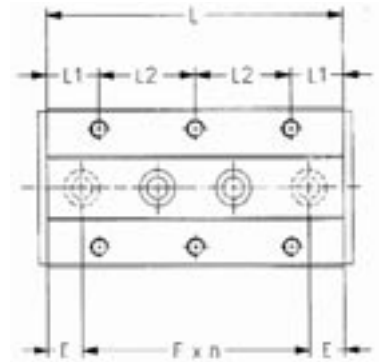
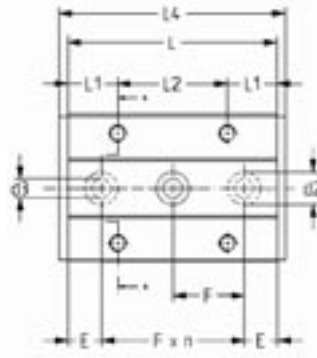
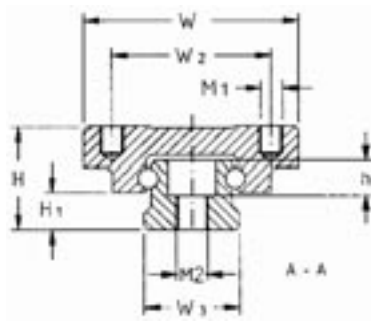

Main dimensions for miniature slide units

Designations	Dimensions									
	W	W ₂	W ₃	L ₂	M ₁ ×depth	d ₃ ×d ₂ ×h	H	H ₁	M ₂	F
	mm									
LZM HS 7	17	12	7	8	M2×2.5	2.5×4.5×2.5	8	2.35	M3	15
LZM HS 9	20	15	9	13	M3×3	3.5×6×3.5	10	3.55	M4	20
LZM HS 12	27	20	12	15	M3×3.5	3.5×6×4.5	13	4.7	M4	25
LZM HS 15	32	25	15	20	M3×4	3.5×6×4.5	16	6	M4	40

5

Designations	Dimensions				Max. stroke	Number of holes		Load-carrying capacities			
	L	L ₄	E	L ₁		Carriage	Rail	C	C ₀	Ma/Mb	Mc
	mm					n	n	N	N	Nm	Nm
LZM HS 7	26	29	5.5	5.0	24	6	2	1000	1700	3.5	6
	34	37	9.5	5.0	34	8	2	1100	2100	5.5	7
	50	53	10.0	5.0	50	12	3	1500	3100	12.0	10
	66	69	10.5	5.0	66	16	4	1800	4100	21.0	14
LZM HS 9	32	35	8.0	9.5	28	4	2	1600	2700	7.0	12
	42	45	11.0	8.0	40	6	2	1900	3400	11.0	15
	55	58	7.5	8.0	54	8	3	2300	4300	18.0	19
	81	84	10.5	8.0	78	12	4	3000	6500	43.0	29
	94	97	7.0	8.0	92	14	5	3300	7400	57.0	33
LZM HS 12	37	40	6.0	11.0	32	4	2	2500	3800	11.0	21
	51	54	13.0	10.5	47	6	2	3100	5300	22.0	28
	66	69	8.0	10.5	62	8	3	3600	6700	36.0	36
	96	99	10.5	10.5	95	12	4	4700	9700	76.0	52
126	129	13.0	10.5	122	16	6	5700	12600	131.0	68	
LZM HS 15	52	56	6.0	12.5	50	4	2	3800	6200	25.0	42
	85	89	22.5	12.5	80	8	2	5400	10400	73.0	70
	105	109	12.5	12.5	102	10	3	6200	12500	106.0	84
	165	169	22.5	12.5	162	16	4	8400	19500	264.0	131



No speed limit here.

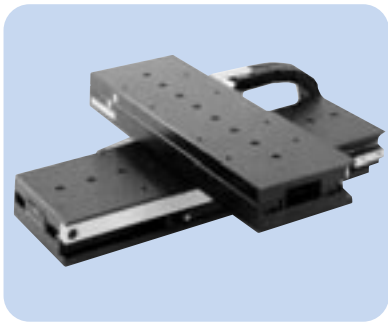

Can you believe that, if a human being could race at a speed proportional to that of a butterfly in full flight, he or she would reach 34,000 kilometres per hour? It's only a hypothesis of course, but enough to inspire us to create tools able to surmount practically any limit including that of speed.

For example, the SKF linear motor slides, which are at their best where conventional slides have reached their limit, combine unbelievable speed with high precision.

Similarly, rotating ball nuts, thanks to the fixed screw, are capable of overcoming the critical speeds usually associated with ball screws, and can reach a speed rating of 90,000 Nd.

With SKF, maximum speed is an everyday norm.

Linear motion from SKF
www.linearmotion.skf.com



Standard slides

Ordering key

	GCLA		
Type:			
Standard slide with crossed roller assemblies of steel	GCL		
Standard slide with crossed roller assemblies of aluminium	GCLA		
Standard slide fitted with either cross roller guides or V-guided ball cages of steel	RM		
Size (see tables):			
.		1	
.		2	
.		3	
.		6	
Rail length [mm] (see tables):			
.			020 - 400

Example:

GCLA	6	400
------	---	-----

5 Positioning systems

Standard slides

GCL

Standard slides with crossed roller assemblies, steel version, for manual positioning

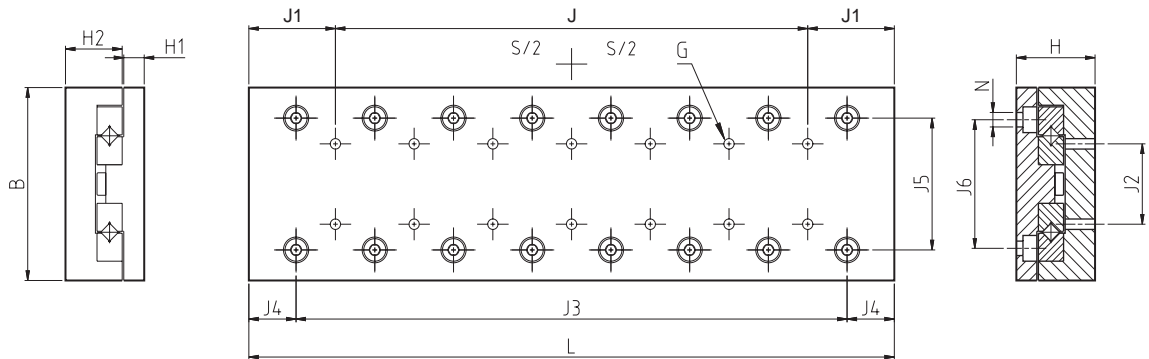

Designations	Dimensions			Stroke		G	H ₁	H ₂	J	J ₁	J ₂	J ₃	J ₄	J ₅
	B	H	L	S ₁ ¹⁾	S ₂ ¹⁾									
mm														
GCL 2030	40	21	35	18	-	M3	6.5	14.0	-	17.5	15	1×15	10	25
GCL 2045	40	21	50	30	-	M3	6.5	14.0	1×15	17.5	15	2×15	10	25
GCL 2060	40	21	65	40	46	M3	6.5	14.0	2×15	17.5	15	3×15	10	25
GCL 2075	40	21	80	50	60	M3	6.5	14.0	3×15	17.5	15	4×15	10	25
GCL 2090	40	21	95	60	75	M3	6.5	14.0	4×15	17.5	15	5×15	10	25
GCL 2105	40	21	110	70	90	M3	6.5	14.0	5×15	17.5	15	6×15	10	25
GCL 2120	40	21	125	80	105	M3	6.5	14.0	6×15	17.5	15	7×15	10	25
GCL 3050	60	28	55	30	-	M4	9.0	18.5	-	27.5	25	1×25	15	39
GCL 3075	60	28	80	45	55	M4	9.0	18.5	1×25	27.5	25	2×25	15	39
GCL 3100	60	28	105	60	80	M4	9.0	18.5	2×25	27.5	25	3×25	15	39
GCL 3125	60	28	130	75	105	M4	9.0	18.5	3×25	27.5	25	4×25	15	39
GCL 3150	60	28	155	90	130	M4	9.0	18.5	4×25	27.5	25	5×25	15	39
GCL 3175	60	28	180	105	155	M4	9.0	18.5	5×25	27.5	25	6×25	15	39
GCL 3200	60	28	205	130	180	M4	9.0	18.5	6×25	27.5	25	7×25	15	39
GCL 6100	100	45	110	60	70	M6	13	31.0	-	55.0	50	1×50	30	64
GCL 6150	100	45	160	95	120	M6	13	31.0	1×50	55.0	50	2×50	30	64
GCL 6200	100	45	210	130	170	M6	13	31.0	2×50	55.0	50	3×50	30	64
GCL 6250	100	45	260	165	220	M6	13	31.0	3×50	55.0	50	4×50	30	64
GCL 6300	100	45	310	200	270	M6	13	31.0	4×50	55.0	50	5×50	30	64
GCL 6400	100	45	410	280	370	M6	13	31.0	6×50	55.0	50	7×50	30	64

¹⁾ S₁ Standard stroke order designation, e.g. GCL 2030
S₂ Extended stroke order designation, e.g. GCL 2030/L

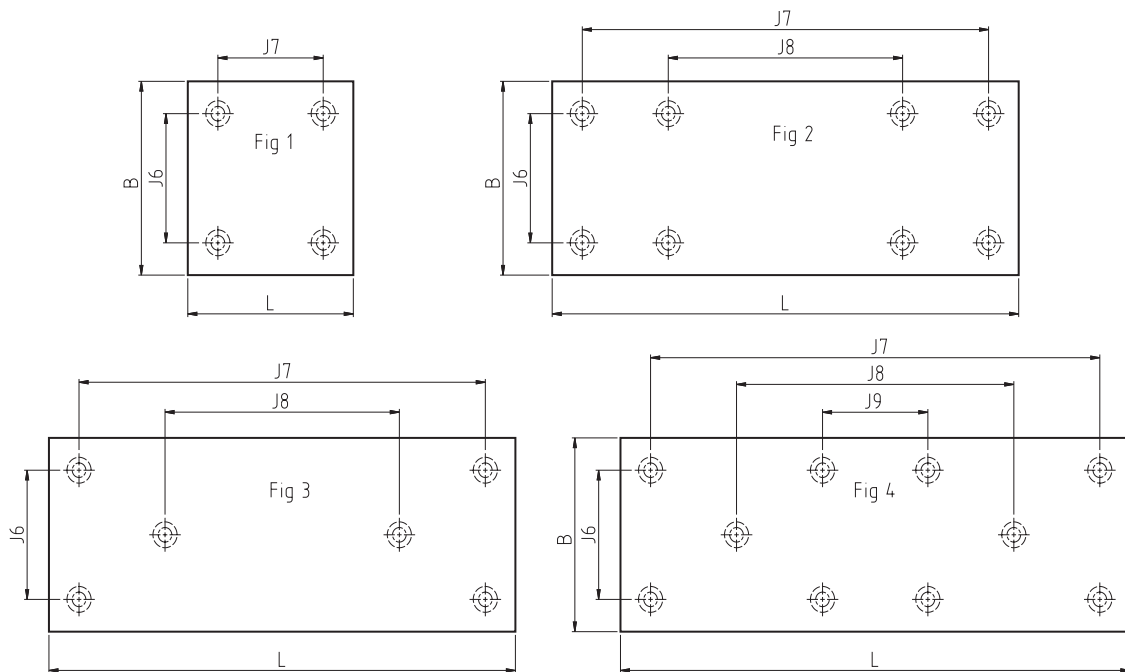

Designations	Dimensions				Fig	N	Load-carrying capacities		Weight
	J ₆	J ₇	J ₈	J ₉			with S ₁	with S ₂	GS
	mm						N	N	kg
GCL 2030	30	25	-	-	1	3.4	250	-	0.18
GCL 2045	30	40	-	-	1	3.4	360	-	0.26
GCL 2060	30	55	-	-	1	3.4	470	430	0.34
GCL 2075	30	70	40	-	2	3.4	580	540	0.42
GCL 2090	30	85	55	-	2	3.4	720	610	0.50
GCL 2105	30	100	70	-	2	3.4	830	720	0.58
GCL 2120	30	115	85	-	2	3.4	940	790	0.68
GCL 3050	40	35	-	-	1	4.5	480	-	0.57
GCL 3075	40	60	-	-	1	4.5	800	720	0.80
GCL 3100	40	85	-	-	1	4.5	1040	880	1.00
GCL 3125	40	110	-	-	1	4.5	1360	1120	1.30
GCL 3150	40	135	85	-	3	4.5	1600	1280	1.50
GCL 3175	40	160	110	-	3	4.5	1920	1520	1.70
GCL 3200	40	185	135	85	4	4.5	2080	1680	2.00
GCL 6100	60	90	-	-	1	6.6	2380	2040	3.10
GCL 6150	60	140	-	-	1	6.6	3740	3060	4.50
GCL 6200	60	190	90	-	3	6.6	4760	4080	5.90
GCL 6250	60	240	140	-	3	6.6	6120	5100	7.20
GCL 6300	60	290	190	-	3	6.6	7140	6120	8.60
GCL 6400	60	390	290	190	4	6.6	7820	6120	11.40

5 Positioning systems

Standard slides

GCLA

Standard slides with slide top and base made of black anodised aluminium, for manual positioning.

In other respects the design is similar to that of the GCL slides except for the slightly reduced height.

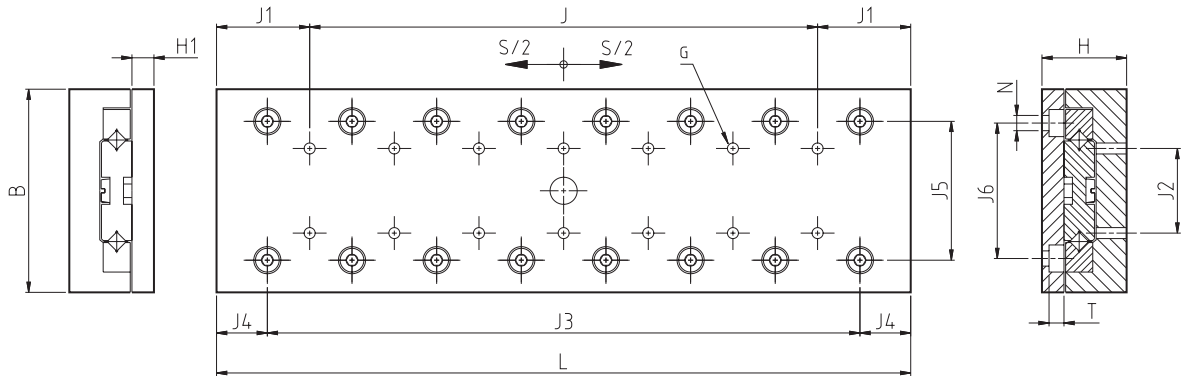

Designations	Dimensions			Stroke		G	H ₁	J	J ₁	J ₂	J ₃	J ₄	J ₅
	B	H	L	S ₁	S ₂ ¹⁾								
mm													
GCLA 2030	40	21	35	15	-	M3	7.00	-	17.5	15	1×15	10	25
GCLA 2045	40	21	50	22	30	M3	7.00	1×15	17.5	15	2×15	10	25
GCLA 2060	40	21	65	30	45	M3	7.00	2×15	17.5	15	3×15	10	25
GCLA 2075	40	21	80	37	60	M3	7.00	3×15	17.5	15	4×15	10	25
GCLA 2090	40	21	95	45	75	M3	7.00	4×15	17.5	15	5×15	10	25
GCLA 2105	40	21	110	52	90	M3	7.00	5×15	17.5	15	6×15	10	25
GCLA 2120	40	21	125	60	105	M3	7.00	6×15	17.5	15	7×15	10	25
GCLA 3050	60	25	55	-	30	M4	8.25	-	27.5	25	1×25	15	41
GCLA 3075	60	25	80	37	55	M4	8.25	1×25	27.5	25	2×25	15	41
GCLA 3100	60	25	105	50	80	M4	8.25	2×25	27.5	25	3×25	15	41
GCLA 3125	60	25	130	62	105	M4	8.25	3×25	27.5	25	4×25	15	41
GCLA 3150	60	25	155	75	130	M4	8.25	4×25	27.5	25	5×25	15	41
GCLA 3175	60	25	180	87	155	M4	8.25	5×25	27.5	25	6×25	15	41
GCLA 3200	60	25	205	100	180	M4	8.25	6×25	27.5	25	7×25	15	41
GCLA 6100	100	40	110	50	70	M6	12.00	-	55.0	50	1×50	30	65
GCLA 6150	100	40	160	75	120	M6	12.00	1×50	55.0	50	2×50	30	65
GCLA 6200	100	40	210	100	170	M6	12.00	2×50	55.0	50	3×50	30	65
GCLA 6250	100	40	260	125	220	M6	12.00	3×50	55.0	50	4×50	30	65
GCLA 6300	100	40	310	150	270	M6	12.00	4×50	55.0	50	5×50	30	65
GCLA 6350	100	40	360	175	320	M6	12.00	5×50	55.0	50	6×50	30	65
GCLA 6400	100	40	410	200	370	M6	12.00	6×50	55.0	50	7×50	30	65

¹⁾ S₂ Extended stroke order designation, e.g. GCL 2030L

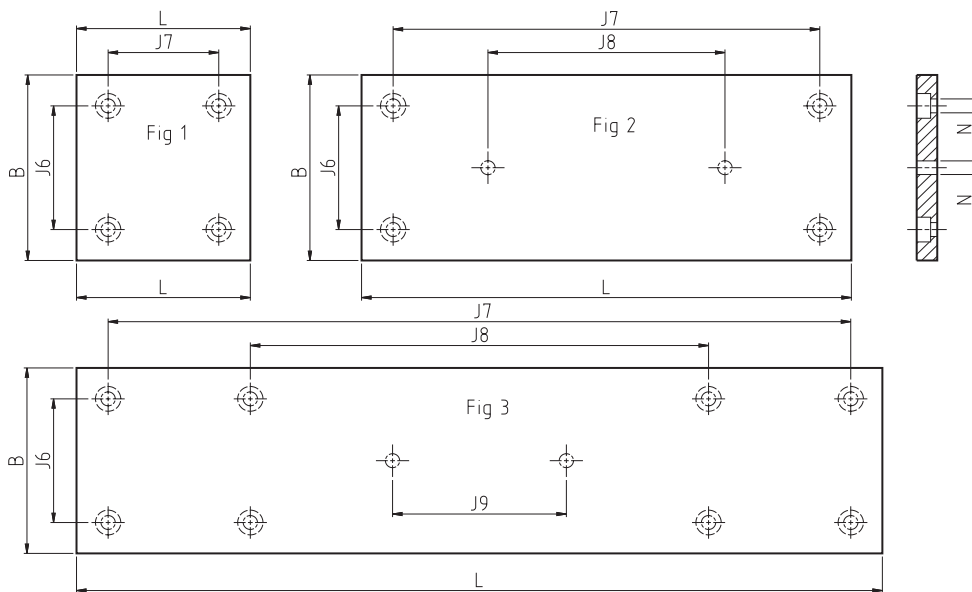

Designations	Dimensions					Fig	N	Load-carrying capacities		Weight GA
	J ₆	J ₇	J ₈	J ₉	with S ₁			with S ₂		
	mm							C ₀	C ₀	
GCLA 2030	30	25	-	-	1	3.8	430	-	0.10	
GCLA 2045	30	40	-	-	1	3.8	688	602	0.14	
GCLA 2060	30	55	-	-	1	3.8	946	774	0.19	
GCLA 2075	30	70	-	-	1	3.8	1204	946	0.23	
GCLA 2090	30	85	45	-	2	3.8	1376	1113	0.28	
GCLA 2105	30	100	50	-	2	3.8	1634	1290	0.32	
GCLA 2120	30	115	30	-	2	3.8	1892	1376	0.37	
GCLA 3050	40	35	-	-	1	4.8	-	952	0.29	
GCLA 3075	40	60	-	-	1	4.8	1496	1224	0.43	
GCLA 3100	40	85	-	-	1	4.8	2040	1632	0.57	
GCLA 3125	40	110	-	-	1	4.8	2448	1904	0.70	
GCLA 3150	40	135	75	-	2	4.8	2992	2312	0.84	
GCLA 3175	40	160	86	-	2	4.8	3536	2584	0.97	
GCLA 3200	40	185	55	-	2	4.8	4080	2992	1.10	
GCLA 6100	60	90	-	-	1	6.8	4320	3780	1.60	
GCLA 6150	60	140	-	-	1	6.8	6480	5400	2.40	
GCLA 6200	60	190	100	-	2	6.8	8640	6480	3.10	
GCLA 6250	60	240	80	-	2	6.8	10800	8100	3.90	
GCLA 6300	60	290	150	-	2	6.8	13500	9720	4.70	
GCLA 6350	60	340	200	80	3	6.8	15660	11340	5.40	
GCLA 6400	60	390	230	90	3	6.8	17820	12420	6.20	

5 Positioning systems

Standard slides/Slides, tables and compact cross tables

RM

Standard slides fitted with either cross roller rail guides or V-guided ball cages, for manual positioning; the opposing V-rails are screwed to a steel base plate. Slide top and bottom carry a standard pattern of mounting holes.

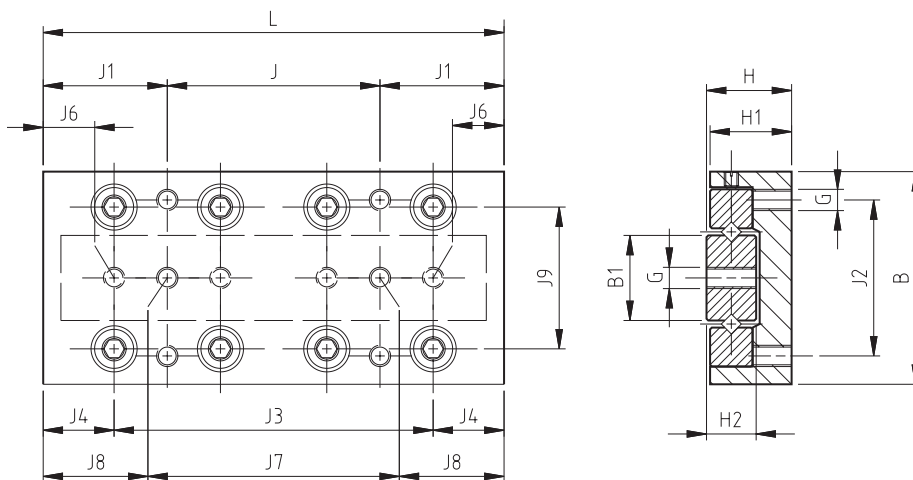

Designations	Dimensions			Stroke						
	B	H	L	S	B ₁	G	H ₁	H ₂	J	J ₁
mm										
RM 1020	20	8	25	12	7	M2.5	7.5	5	1×18	3.5
RM 1030	20	8	35	18	7	M2.5	7.5	5	1×28	3.5
RM 1040	20	8	45	25	7	M2.5	7.5	5	1×20	12.5
RM 1050	20	8	55	32	7	M2.5	7.5	5	1×30	12.5
RM 2060	30	12	65	40	12	M3	11.5	7	1×30	17.5
RM 2075	30	12	80	50	12	M3	11.5	7	1×45	17.5
RM 2090	30	12	95	60	12	M3	11.5	7	2×30	17.5
RM 3100	40	16	105	60	16	M4	15.5	9	1×50	27.5
RM 3125	40	16	130	75	16	M4	15.5	9	1×75	27.5
RM 3150	40	16	155	90	16	M4	15.5	9	2×50	27.5

continued

Designations	Dimensions									Load-carrying capacities	Weight
	J ₂	J ₃	J ₄	J ₅	J ₆	J ₇	J ₈	J ₉	C ₀		
	mm									N	kg
RM 1020	14	1×10	7.5	2×7.5	5.0	1×18	3.5	12.6	208	0.025	
RM 1030	14	2×10	7.5	2×10	7.5	1×20	7.5	12.6	364	0.025	
RM 1040	14	3×10	7.5	3×10	7.5	1×28	8.5	12.6	464	0.025	
RM 1050	14	4×10	7.5	4×10	7.5	1×30	12.5	12.6	572	0.025	
RM 2060	22	3×15	10.0	3×15	10.0	-	-	20.0	860	0.160	
RM 2075	22	4×15	10.0	4×15	10.0	-	-	20.0	1032	0.190	
RM 2090	22	5×15	10.0	5×15	10.0	-	-	20.0	1290	0.230	
RM 3100	30	3×25	15.0	3×25	15.0	-	-	28.5	1904	0.460	
RM 3125	30	4×25	15.0	4×25	15.0	-	-	28.5	2312	0.580	
RM 3150	30	5×25	15.0	5×25	15.0	-	-	28.5	2856	0.690	

continued

Slides, tables and compact cross tables

Ordering key

	R	SS					
Type:							
Precision slides with rail guide system, crossed rollers	R						
Dovetail slides		S					
Compact cross tables with rail guide system, crossed rollers			T				
Versions:							
Only valid for dovetail tables:							
For manual operation, with micrometer knurl						SM	
For manual operation, with hand crank						SK	
Only valid for precision tables:							
For manual operation, with micrometer knurl						SM	
For manual operation, with hand crank						SK	
For motor drive						SS	
Only valid for compact cross tables:							
For manual operation, without drive						0	
For manual operation, with micrometer knurl						S	
Table width B [mm] (see tables):							85 - 300
Length L1 or dimension Sx Sy [mm]:							
L1 for dovetail and precision slides							80 - 1010
Sx Sy for compact cross tables							025, 050, 100
Nominal stroke [mm] (not for compact cross tables):							
See tables							
Designation suffix if desired:							
Slides or tables made of aluminium, black anodised							A
Slides with thick top: only for precision slides							D
Slides with thick top and T-slots: dovetail and precision slides							DT
Locking device for dovetail slides (standard)							AR 1
Locking device for precision slides and tables							AR 2
Locking device for compact cross tables (standard)							AR 3
For motor drive only:							
Preloaded planetary roller screw for RSS - slides							R
Screw diameter Ø in mm:							
Precision tables for RSS - slides							8 - 20
Screw lead:							
1 - 5 mm for RSS - slides							01 - 15

Example 1: R SS 200 - 710 - 300 - - R 1202

Example 2: R SK 50 - 080 - 025

Example 3: S SM 300 - 010 - 500 - AR1

Example 4: S SK 50 - 080 - 025 - AR1

Example 5: T 0 085 - 050 - - AR3

5 Positioning systems

Dovetail slides

Dovetail slides

SSM / SSK

SSM – with micrometer ring with spring preloading, allowing easy turning. One division equals 0,02 mm.

SSK – as **SSM**, but instead of knurled screw equipped with crank handle.

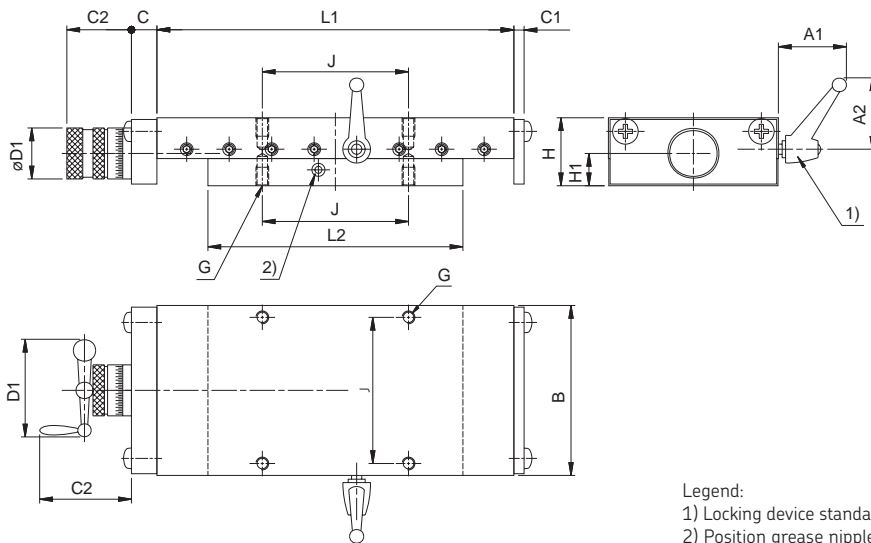

Legend:
1) Locking device standard
2) Position grease nipple

Designations	Dimensions				Stroke								Screw			Weight	
	B	H	L ₁	L ₂	S	A ₁	A ₂	C	C ₁	C ₂	D ₁	H ₁	Ø	J	G	GG	
	mm																kg
SSM-50.080.025	50	25	80	50	25	37	42	19	6	31	23.5	12.3	M6x1	37	M4	0.7	
SSK-50.080.025	50	25	80	25	25	37	42	19	6	51	47.0	12.3	M6x1	37	M4	0.7	
SSM-50.130.025	50	25	130	25	25	37	42	19	6	31	23.5	12.3	M6x1	37	M4	1.2	
SSK-50.130.025	50	25	130	25	25	37	42	19	6	51	47.0	12.3	M6x1	37	M4	1.2	
SSM-50.130.050	50	25	130	50	50	37	42	19	6	31	23.5	12.3	M6x1	37	M4	1.0	
SSK-50.130.050	50	25	130	50	50	37	42	19	6	51	47.0	12.3	M6x1	37	M4	1.0	
SSM-50.155.050	50	25	155	50	50	37	42	19	6	31	23.5	12.3	M6x1	37	M4	1.3	
SSK-50.155.050	50	25	155	50	50	37	42	19	6	51	47.0	12.3	M6x1	37	M4	1.3	
SSM-50.155.075	50	25	155	75	75	37	42	19	6	31	23.5	12.3	M6x1	37	M4	1.2	
SSK-50.155.075	50	25	155	75	75	37	42	19	6	51	47.0	12.3	M6x1	37	M4	1.2	
SSM-50.180.075	50	25	180	75	75	37	42	19	6	31	23.5	12.3	M6x1	37	M4	1.4	
SSK-50.180.075	50	25	180	75	75	37	42	19	6	51	47.0	12.3	M6x1	37	M4	1.4	
SSM-50.205.100	50	25	205	100	100	37	42	19	6	31	23.5	12.3	M6x1	37	M4	1.7	
SSK-50.205.100	50	25	205	100	100	37	42	19	6	51	47.0	12.3	M6x1	37	M4	1.7	
SSM-75.105.025	75	32	105	75	25	38	42	21	6	38	30.0	15	M10x1	62	M5	1.9	
SSK-75.105.025	75	32	105	75	25	38	42	21	6	54	47.0	15	M10x1	62	M5	1.9	
SSM-75.155.050	75	32	155	100	50	38	42	21	6	38	30.0	15	M10x1	62	M5	2.6	
SSK-75.155.050	75	32	155	100	50	38	42	21	6	54	47.0	15	M10x1	62	M5	2.6	
SSM-75.205.050	75	32	205	150	50	38	42	21	6	38	30.0	15	M10x1	62	M5	3.4	
SSK-75.205.050	75	32	205	150	50	38	42	21	6	54	47.0	15	M10x1	62	M5	3.4	
SSM-75.155.075	75	32	155	75	75	38	42	21	6	38	30.0	15	M10x1	62	M5	2.3	
SSK-75.155.075	75	32	155	75	75	38	42	21	6	54	47.0	15	M10x1	62	M5	2.3	
SSM-75.180.075	75	32	180	100	75	38	42	21	6	38	30.0	15	M10x1	62	M5	2.8	
SSK-75.180.075	75	32	180	100	75	38	42	21	6	54	47.0	15	M10x1	62	M5	2.8	
SSM-75.205.100	75	32	205	100	100	38	42	21	6	38	30.0	15	M10x1	62	M5	3.0	
SSK-75.205.100	75	32	205	100	100	38	42	21	6	54	47.0	15	M10x1	62	M5	3.0	
SSM-75.255.100	75	32	255	150	100	38	42	21	6	38	30.0	15	M10x1	62	M5	3.8	
SSK-75.255.100	75	32	255	150	100	38	42	21	6	54	47.0	15	M10x1	62	M5	3.8	
SSM-75.305.150	75	32	305	150	150	38	42	21	6	38	30.0	15	M10x1	62	M5	4.2	
SSK-75.305.150	75	32	305	150	150	38	42	21	6	54	47.0	15	M10x1	62	M5	4.2	

continued

SSM / SSK
(continued)

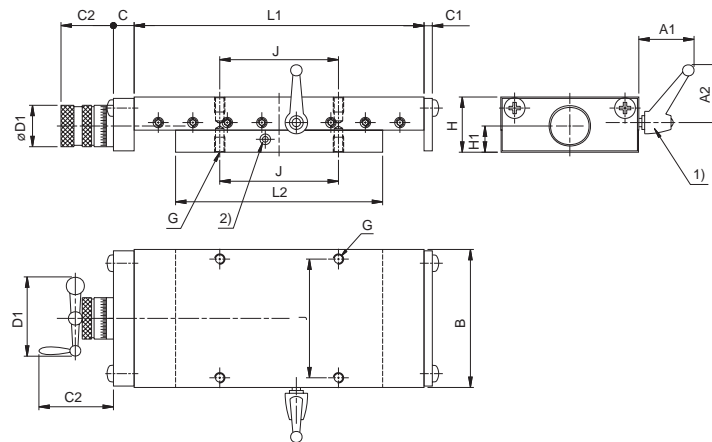

Legend:
1) Locking device standard
2) Position grease nipple

continued

5

Designations	Dimensions				Stroke								Screw			Weight
	B	H	L ₁	L ₂	S	A ₁	A ₂	C	C ₁	C ₂	D ₁	H ₁	Ø	J	G	GG
	mm															
SSM-100.160.050	100	40	160	100	50	40	45	21	6	38	30	19	M10x1	74	M6	4.4
SSK-100.160.050	100	40	160	100	50	40	45	21	6	54	47	19	M10x1	74	M6	4.4
SSM-100.260.050	100	40	260	200	50	40	45	21	6	38	30	19	M10x1	74	M6	7.2
SSK-100.260.050	100	40	260	200	50	40	45	21	6	54	47	19	M10x1	74	M6	7.2
SSM-100.210.100	100	40	210	100	100	40	45	21	6	38	30	19	M10x1	74	M6	5.1
SSK-100.210.100	100	40	210	100	100	40	45	21	6	54	47	19	M10x1	74	M6	5.1
SSM-100.310.100	100	40	310	200	100	40	45	21	6	38	30	19	M10x1	74	M6	7.9
SSK-100.310.100	100	40	310	200	100	40	45	21	6	54	47	19	M10x1	74	M6	7.9
SSM-100.310.150	100	40	310	150	150	40	45	21	6	38	30	19	M10x1	74	M6	7.1
SSK-100.310.150	100	40	310	150	150	40	45	21	6	54	47	19	M10x1	74	M6	7.1
SSM-100.410.150	100	40	410	250	150	40	45	21	6	38	30	19	M10x1	74	M6	10.0
SSK-100.410.150	100	40	410	250	150	40	45	21	6	54	47	19	M10x1	74	M6	10.0
SSM-100.410.200	100	40	410	200	200	40	45	21	6	38	30	19	M10x1	74	M6	9.2
SSK-100.410.200	100	40	410	200	200	40	45	21	6	54	47	19	M10x1	74	M6	9.2
SSM-100.510.200	100	40	510	300	200	40	45	21	6	38	30	19	M10x1	74	M6	12.1
SSK-100.510.200	100	40	510	300	200	40	45	21	6	54	47	19	M10x1	74	M6	12.1
SSM-150.310.100	150	50	310	200	100	45	62	28	8	53	47	24	Tr16x2	130	M8	15.4
SSK-150.310.100	150	50	310	200	100	45	62	28	8	92	103	24	Tr16x2	130	M8	15.4
SSM-150.510.100	150	50	510	400	100	45	62	28	8	53	47	24	Tr16x2	130	M8	26.0
SSK-150.510.100	150	50	510	400	100	45	62	28	8	92	103	24	Tr16x2	130	M8	26.0
SSM-150.410.200	150	50	410	200	200	45	62	28	8	53	47	24	Tr16x2	130	M8	17.8
SSK-150.410.200	150	50	410	200	200	45	62	28	8	92	103	24	Tr16x2	130	M8	17.8
SSM-150.610.200	150	50	610	400	200	45	62	28	8	53	47	24	Tr16x2	130	M8	28.5
SSK-150.610.200	150	50	610	400	200	45	62	28	8	92	103	24	Tr16x2	130	M8	28.5
SSM-150.510.300	150	50	510	200	300	45	62	28	8	53	47	24	Tr16x2	130	M8	20.2
SSK-150.510.300	150	50	510	200	300	45	62	28	8	92	103	24	Tr16x2	130	M8	20.2
SSM-150.710.300	150	50	710	400	300	45	62	28	8	53	47	24	Tr16x2	130	M8	30.9
SSK-150.710.300	150	50	710	400	300	45	62	28	8	92	103	24	Tr16x2	130	M8	30.9
SSM-150.710.400	150	50	710	300	400	45	62	28	8	53	47	24	Tr16x2	130	M8	28.0
SSK-150.710.400	150	50	710	300	400	45	62	28	8	92	103	24	Tr16x2	130	M8	28.0
SSM-150.810.400	150	50	810	400	400	45	62	28	8	53	47	24	Tr16x2	130	M8	33.3
SSK-150.810.400	150	50	810	400	400	45	62	28	8	92	103	24	Tr16x2	130	M8	33.3

continued

5 Positioning systems
Dovetail slides/Compact cross tables

SSM / SSK
(continued)

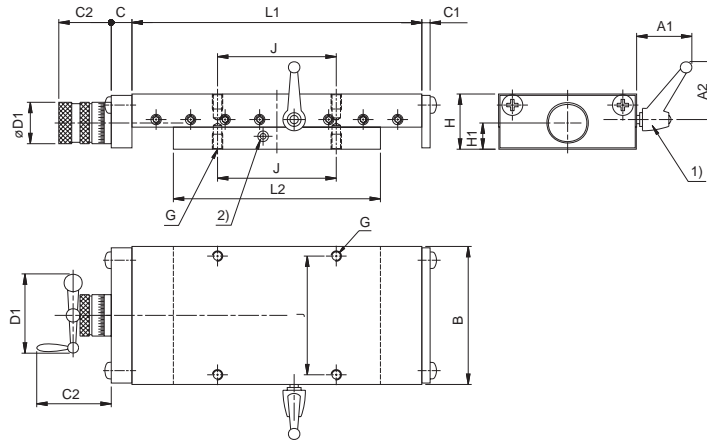

Legend:
1) Locking device standard
2) Position grease nipple

continued

Designations	Dimensions				Stroke				Screw			Weight				
	B	H	L ₁	L ₂	S	A ₁	A ₂	C	C ₁	C ₂	D ₁	H ₁	Ø	J	G	GG
	mm															kg
SSM-200.310.100	200	60	310	200	100	45	62	28	8	53	47	25.0	Tr16x2	170	M8	24.7
SSK-200.310.100	200	60	310	200	100	45	62	28	8	92	103	25.0	Tr16x2	170	M8	24.7
SSM-200.410.100	200	60	410	300	100	45	62	28	8	53	47	25.0	Tr16x2	170	M8	33.2
SSK-200.410.100	200	60	410	300	100	45	62	28	8	92	103	25.0	Tr16x2	170	M8	33.2
SSM-200.510.200	200	60	510	300	200	45	62	28	8	53	47	25.0	Tr16x2	170	M8	37.2
SSK-200.510.200	200	60	510	300	200	45	62	28	8	92	103	25.0	Tr16x2	170	M8	37.2
SSM-200.610.200	200	60	610	400	200	45	62	28	8	53	47	25.0	Tr16x2	170	M8	45.7
SSK-200.610.200	200	60	610	400	200	45	62	28	8	92	103	25.0	Tr16x2	170	M8	45.7
SSM-200.610.300	200	60	610	300	300	45	62	28	8	53	47	25.0	Tr16x2	170	M8	41.1
SSK-200.610.300	200	60	610	300	300	45	62	28	8	92	103	25.0	Tr16x2	170	M8	41.1
SSM-200.710.300	200	60	710	400	300	45	62	28	8	53	47	25.0	Tr16x2	170	M8	49.6
SSK-200.710.300	200	60	710	400	300	45	62	28	8	92	103	25.0	Tr16x2	170	M8	49.6
SSM-200.710.400	200	60	710	300	400	45	62	28	8	53	47	25.0	Tr16x2	170	M8	45.0
SSK-200.710.400	200	60	710	300	400	45	62	28	8	92	103	25.0	Tr16x2	170	M8	45.0
SSM-200.810.400	200	60	810	400	400	45	62	28	8	53	47	25.0	Tr16x2	170	M8	53.5
SSK-200.810.400	200	60	810	400	400	45	62	28	8	92	103	25.0	Tr16x2	170	M8	53.5
SSM-300.410.100	300	75	410	300	100	55	74	20	10	80	66	34.5	Tr20x4	260	M10	64.6
SSK-300.410.100	300	75	410	300	100	55	74	20	10	146	125	34.5	Tr20x4	260	M10	64.6
SSM-300.510.100	300	75	510	400	100	55	74	20	10	80	66	34.5	Tr20x4	260	M10	80.7
SSK-300.510.100	300	75	510	400	100	55	74	20	10	146	125	34.5	Tr20x4	260	M10	80.7
SSM-300.510.200	300	75	510	300	200	55	74	20	10	80	66	34.5	Tr20x4	260	M10	72.4
SSK-300.510.200	300	75	510	300	200	55	74	20	10	146	125	34.5	Tr20x4	260	M10	72.4
SSM-300.610.200	300	75	610	400	200	55	74	20	10	80	66	34.5	Tr20x4	260	M10	88.6
SSK-300.610.200	300	75	610	400	200	55	74	20	10	146	125	34.5	Tr20x4	260	M10	88.6
SSM-300.710.300	300	75	710	400	300	55	74	20	10	80	66	34.5	Tr20x4	260	M10	96.4
SSK-300.710.300	300	75	710	400	300	55	74	20	10	146	125	34.5	Tr20x4	260	M10	96.4
SSM-300.810.400	300	75	810	400	400	55	74	20	10	80	66	34.5	Tr20x4	260	M10	104.3
SSK-300.810.400	300	75	810	400	400	55	74	20	10	146	125	34.5	Tr20x4	260	M10	104.3
SSM-300.1010.500	300	75	1010	500	500	55	74	20	10	80	66	34.5	Tr20x4	260	M10	128.3
SSK-300.1010.500	300	75	1010	500	500	55	74	20	10	146	125	34.5	Tr20x4	260	M10	128.3

Compact cross tables

T0 / TS

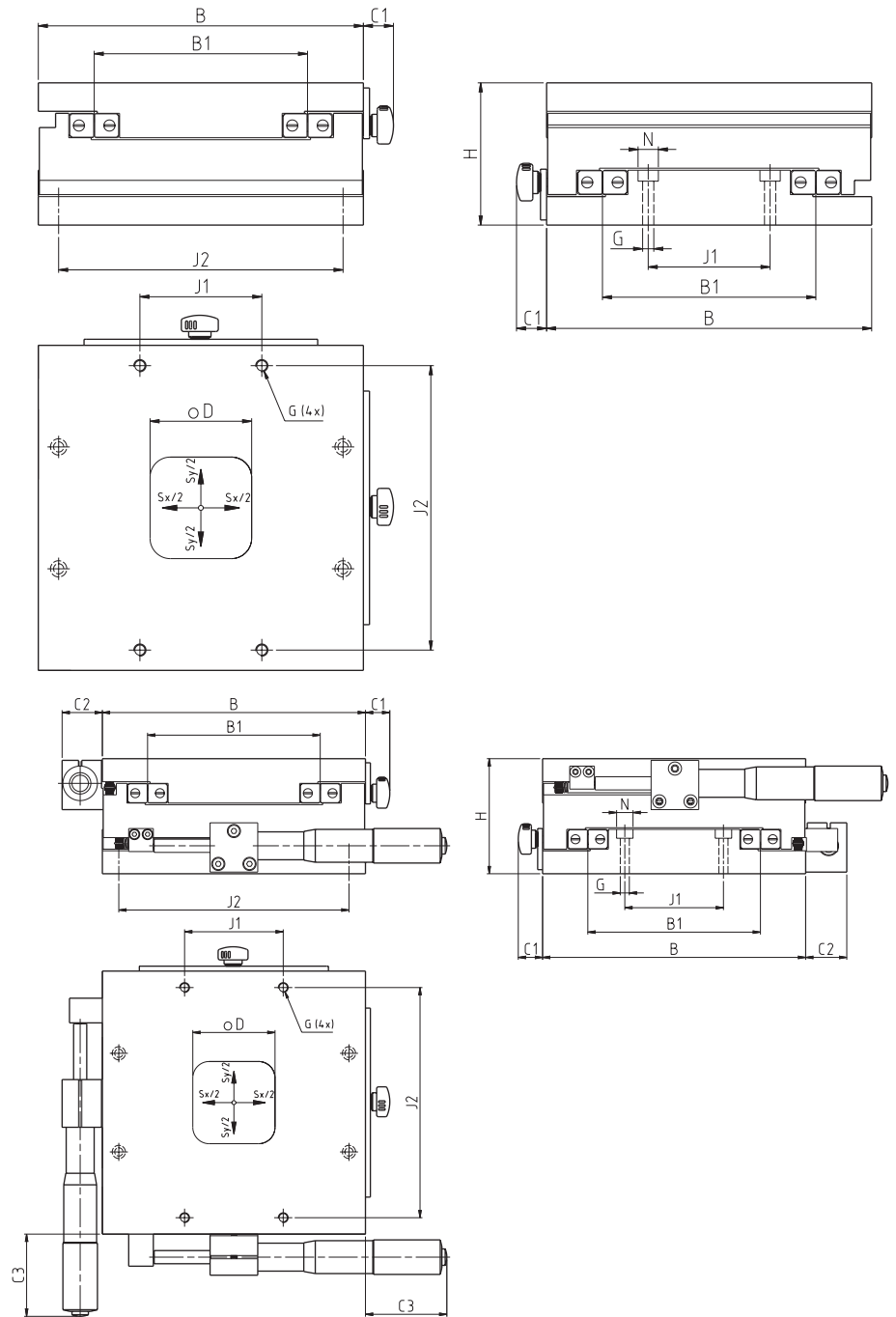

5

Designations	Dimensions		Stroke				Load-carrying capacities				Weight			
	B	H	Sx	Sy	B ₁	C ₁	C ₂	C ₃	D	N	G	J ₁	J ₂	C ₀
mm														
N														
kg														
T0 085	85	40	50	48	16	-	-	22	∅ 4.2 / ∅ 8 × 4.5 (4x)	M5	20	70	3 400	0.8
TS 085	85	40	25	48	16	22.5	33	22	-	M5	20	70	4 200	1.1
T0 160	160	70	100	105	15	-	-	50	∅ 5 / ∅ 10 × 5.5 (4x)	M6	60	140	12 400	4.0
TS 160	160	70	50	105	15	25.0	50	50	-	M6	60	140	15 600	4.8

5 Positioning systems

Precision slides

Precision slides

RSM / RSK

Precision tables for manual operation with micrometer knurl RSM, with hand crank RSK

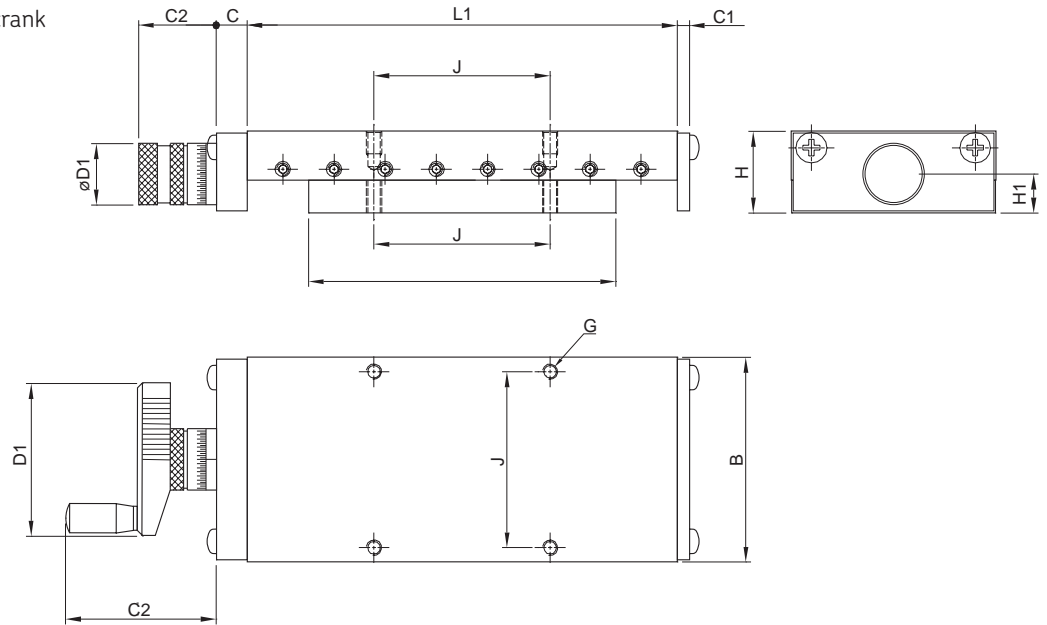

Designations	Dimensions			Stroke				Screw					Load-carrying capacities	Weight		
	B	H	L ₁	L ₂	S	C	C ₁	C ₂	D ₁	H ₁	∅	J			G	N
mm															kN	kg
RSM50.080.025	50	25	80	55	25	14	5	37.5	23	12.3	M6×1	37	M4	4.5	1.70	0.7
RSM50.130.025	50	25	130	105	25	14	5	37.5	23	12.3	M6×1	37	M4	4.5	3.30	1.1
RSM50.130.050	50	25	130	80	50	14	5	37.5	23	12.3	M6×1	37	M4	4.5	2.50	1.0
RSM50.130.075	50	25	130	55	75	14	5	37.5	23	12.3	M6×1	37	M4	4.5	1.70	0.9
RSM50.180.075	50	25	180	105	75	14	5	37.5	23	12.3	M6×1	37	M4	4.5	3.30	1.3
RSM50.180.100	50	25	180	80	100	14	5	37.5	23	12.3	M6×1	37	M4	4.5	2.50	1.2
RSM75.130.025	75	32	130	105	25	15	6	46.0	30	15	M10×1	62	M4	4.5	3.40	2.2
RSK75.130.025	75	32	130	105	25	15	6	88.0	71	15	M10×1	62	M4	4.5	3.40	2.2
RSM75.180.050	75	32	180	130	50	15	6	46.0	30	15	M10×1	62	M4	4.5	5.10	3.0
RSK75.180.050	75	32	180	130	50	15	6	88.0	71	15	M10×1	62	M4	4.5	5.10	3.0
RSM75.180.025	75	32	180	150	50	15	6	46.0	30	15	M10×1	62	M4	4.5	4.25	2.8
RSK75.180.025	75	32	180	150	50	15	6	88.0	71	15	M10×1	62	M4	4.5	4.25	2.8
RSM75.180.075	75	32	180	105	75	15	6	46.0	30	15	M10×1	62	M4	4.5	3.40	2.6
RSK75.180.075	75	32	180	105	75	15	6	88.0	71	15	M10×1	62	M4	4.5	3.40	2.6
RSM75.230.075	75	32	230	155	75	15	6	46.0	30	15	M10×1	62	M4	4.5	5.10	3.4
RSK75.230.075	75	32	230	155	75	15	6	88.0	71	15	M10×1	62	M4	4.5	5.10	3.4
RSM75.230.075	75	32	230	130	100	15	6	46.0	30	15	M10×1	62	M4	4.5	4.25	3.3
RSK75.230.075	75	32	230	130	100	15	6	88.0	71	15	M10×1	62	M4	4.5	4.25	3.3
RSM75.230.075	75	32	230	105	125	15	6	46.0	30	15	M10×1	62	M4	4.5	3.40	3.1
RSK75.230.075	75	32	230	105	125	15	6	88.0	71	15	M10×1	62	M4	4.5	3.40	3.1

continued

continued

Designations	Dimensions				Stroke				Screw						Load-carrying capacities	Weight	
	B	H	L ₁	L ₂	S	C	C ₁	C ₂	D ₁	H ₁	Ø	J	G	N	C ₀	GG	
	mm																kN
RSM100.260.050	100	40	260	210	50	15	6	46	30	15.5	M10×1	74	M6	6.6	8.8	6.8	
RSK100.260.050	100	40	260	210	50	15	6	88	71	15.5	M10×1	74	M6	6.6	8.8	6.8	
RSM100.310.050	100	40	310	260	50	15	6	46	30	15.5	M10×1	74	M6	6.6	10.9	8.2	
RSK100.310.050	100	40	310	260	50	15	6	88	71	15.5	M10×1	74	M6	6.6	10.9	8.2	
RSM100.360.050	100	40	360	310	50	15	6	46	30	15.5	M10×1	74	M6	6.6	13.0	9.6	
RSK100.360.050	100	40	360	310	50	15	6	88	71	15.5	M10×1	74	M6	6.6	13.0	9.6	
RSM100.310.100	100	40	310	210	100	15	6	46	30	15.5	M10×1	74	M6	6.6	8.8	7.5	
RSK100.310.100	100	40	310	210	100	15	6	88	71	15.5	M10×1	74	M6	6.6	8.8	7.5	
RSM100.360.100	100	40	360	260	100	15	6	46	30	15.5	M10×1	74	M6	6.6	10.9	8.9	
RSK100.360.100	100	40	360	260	100	15	6	88	71	15.5	M10×1	74	M6	6.6	10.9	8.9	
RSM100.410.100	100	40	410	310	100	15	6	46	30	15.5	M10×1	74	M6	6.6	13.0	10.0	
RSK100.410.100	100	40	410	310	100	15	6	88	71	15.5	M10×1	74	M6	6.6	13.0	10.0	
RSM100.360.150	100	40	360	210	150	15	6	46	30	15.5	M10×1	74	M6	6.6	8.8	8.2	
RSK100.360.150	100	40	360	210	150	15	6	88	71	15.5	M10×1	74	M6	6.6	8.8	8.2	
RSM100.410.150	100	40	410	260	150	15	6	46	30	15.5	M10×1	74	M6	6.6	10.9	9.6	
RSK100.410.150	100	40	410	260	150	15	6	88	71	15.5	M10×1	74	M6	6.6	10.9	9.6	
RSM100.460.150	100	40	460	310	150	15	6	46	30	15.5	M10×1	74	M6	6.6	13.0	11.0	
RSK100.460.150	100	40	460	310	150	15	6	88	71	15.5	M10×1	74	M6	6.6	13.0	11.0	
RSM100.460.200	100	40	460	260	200	15	6	46	30	15.5	M10×1	74	M6	6.6	10.9	10.0	
RSK100.460.200	100	40	460	260	200	15	6	88	71	15.5	M10×1	74	M6	6.6	10.9	10.0	
RSM150.410.100	150	50	410	310	100	20	8	63	47	24.0	Tr16×2	116	M8	9	53.0	20.0	
RSK150.410.100	150	50	410	310	100	20	8	122	102	24.0	Tr16×2	116	M8	9	53.0	20.0	
RSM150.510.100	150	50	510	410	100	20	8	63	47	24.0	Tr16×2	116	M8	9	71.0	25.0	
RSK150.510.100	150	50	510	410	100	20	8	122	102	24.0	Tr16×2	116	M8	9	71.0	25.0	
RSM150.610.100	150	50	610	510	100	20	8	63	47	24.0	Tr16×2	116	M8	9	88.0	30.0	
RSK150.610.100	150	50	610	510	100	20	8	122	102	24.0	Tr16×2	116	M8	9	88.0	30.0	
RSM150.510.200	150	50	510	310	200	20	8	63	47	24.0	Tr16×2	116	M8	9	53.0	22.0	
RSK150.510.200	150	50	510	310	200	20	8	122	102	24.0	Tr16×2	116	M8	9	53.0	22.0	
RSM150.610.200	150	50	610	410	200	20	8	63	47	24.0	Tr16×2	116	M8	9	71.0	28.0	
RSK150.610.200	150	50	610	410	200	20	8	122	102	24.0	Tr16×2	116	M8	9	71.0	28.0	
RSM150.710.200	150	50	710	510	200	20	8	63	47	24.0	Tr16×2	116	M8	9	88.0	33.0	
RSK150.710.200	150	50	710	510	200	20	8	122	102	24.0	Tr16×2	116	M8	9	88.0	33.0	
RSM150.610.300	150	50	610	310	300	20	8	63	47	24.0	Tr16×2	116	M8	9	53.0	25.0	
RSK150.610.300	150	50	610	310	300	20	8	122	102	24.0	Tr16×2	116	M8	9	53.0	25.0	
RSM150.710.300	150	50	710	410	300	20	8	63	47	24.0	Tr16×2	116	M8	9	71.0	30.0	
RSK150.710.300	150	50	710	410	300	20	8	122	102	24.0	Tr16×2	116	M8	9	71.0	30.0	
RSM150.810.300	150	50	810	510	300	20	8	63	47	24.0	Tr16×2	116	M8	9	88.0	36.0	
RSK150.810.300	150	50	810	510	300	20	8	122	102	24.0	Tr16×2	116	M8	9	88.0	36.0	
RSM150.810.400	150	50	810	410	400	20	8	63	47	24.0	Tr16×2	116	M8	9	71.0	33.0	
RSK150.810.400	150	50	810	410	400	20	8	122	102	24.0	Tr16×2	116	M8	9	71.0	33.0	

5 Positioning systems

Precision slides

RSS

Precision slides with crossed roller units and pre-loaded planetary roller screws

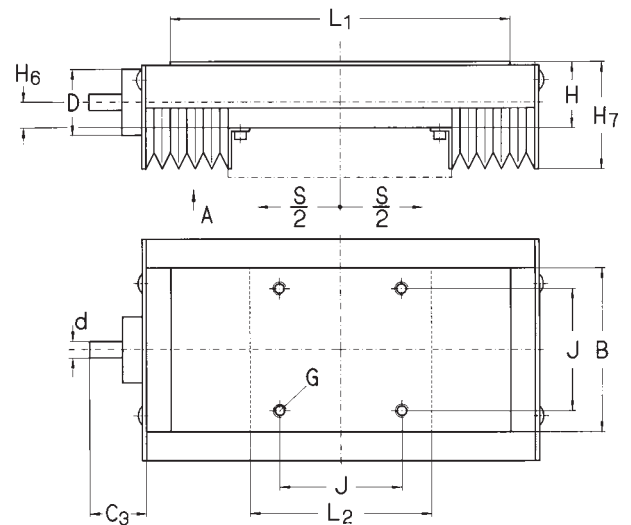
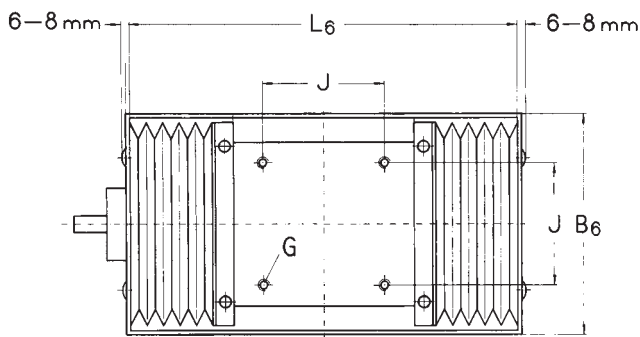

Designations	Dimensions			Stroke Maximum stroke between end stops										Load-carrying capacities			
	B	H	L ₁	L ₂	S	B ₆	C ₃	d	D	H ₆	H ₇	J	L ₆	G	N	C ₀	
mm																kN	
RSS100.260.050	100	40	260	210	50	164	19	5	30	15.5	65	74	290	M6	6.6	8.8	
RSS100.310.050	100	40	310	260	50	164	19	5	30	15.5	65	74	340	M6	6.6	10.9	
RSS100.360.050	100	40	360	310	50	164	19	5	30	15.5	65	74	390	M6	6.6	13.0	
RSS100.310.100	100	40	310	210	100	164	19	5	30	15.5	65	74	340	M6	6.6	8.8	
RSS100.360.100	100	40	360	260	100	164	19	5	30	15.5	65	74	390	M6	6.6	10.9	
RSS100.410.100	100	40	410	310	100	164	19	5	30	15.5	65	74	440	M6	6.6	13.0	
RSS100.360.150	100	40	360	210	150	164	19	5	30	15.5	65	74	390	M6	6.6	8.8	
RSS100.410.150	100	40	410	260	150	164	19	5	30	15.5	65	74	440	M6	6.6	10.9	
RSS100.460.150	100	40	460	310	150	164	19	5	30	15.5	65	74	490	M6	6.6	13.0	
RSS100.460.200	100	40	460	260	200	164	19	5	30	15.5	65	74	490	M6	6.6	10.9	
RSS200.410.100	200	60	410	310	100	264	30	10	47	25.0	85	154	450	M8	9.0	53.0	
RSS200.510.100	200	60	510	410	100	264	30	10	47	25.0	85	154	550	M8	9.0	71.0	
RSS200.610.100	200	60	610	510	100	264	30	10	47	25.0	85	154	650	M8	9.0	88.0	
RSS200.510.200	200	60	510	310	200	264	30	10	47	25.0	85	154	550	M8	9.0	53.0	
RSS200.610.200	200	60	610	410	200	264	30	10	47	25.0	85	154	650	M8	9.0	71.0	
RSS200.710.200	200	60	710	510	200	264	30	10	47	25.0	85	154	750	M8	9.0	88.0	
RSS200.610.300	200	60	610	310	300	264	30	10	47	25.0	85	154	650	M8	9.0	53.0	
RSS200.710.300	200	60	710	410	300	264	30	10	47	25.0	85	154	750	M8	9.0	71.0	
RSS200.810.300	200	60	810	510	300	264	30	10	47	25.0	85	154	850	M8	9.0	88.0	
RSS200.810.400	200	60	810	410	400	264	30	10	47	25.0	85	154	850	M8	9.0	53.0	
RSS200.910.400	200	60	910	510	400	264	30	10	47	25.0	85	154	950	M8	9.0	71.0	

continued

RSS
(continued)

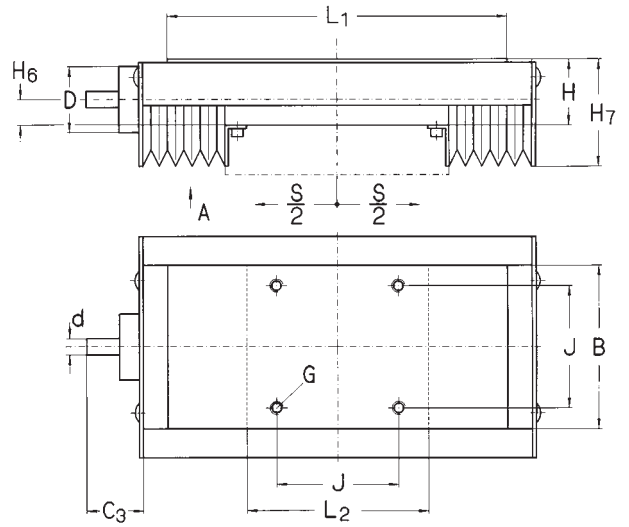
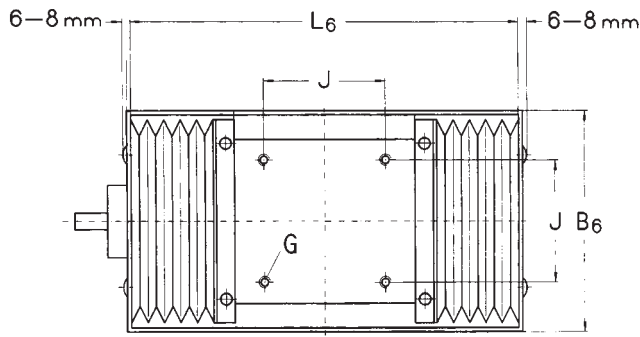

continued

Designations	Dimensions			Stroke Maximum stroke between end stops							Load-carrying capacities					
	B	H	L ₁	L ₂	S	B ₆	C ₃	d	D	H ₆	H ₇	J	L ₆	G	N	C ₀
mm																kN
RSS300.515.100	300	75	515	415	100	364	36	10	55	28	100	245	559	M10	11	58
RSS300.615.100	300	75	615	515	100	364	36	10	55	28	100	245	659	M10	11	73
RSS300.515.200	300	75	515	315	200	364	36	10	55	28	100	245	559	M10	11	31
RSS300.615.200	300	75	615	415	200	364	36	10	55	28	100	245	659	M10	11	49
RSS300.715.200	300	75	715	515	200	364	36	10	55	28	100	245	759	M10	11	64
RSS300.615.300	300	75	615	315	300	364	36	10	55	28	100	245	659	M10	11	24
RSS300.715.300	300	75	715	415	300	364	36	10	55	28	100	245	759	M10	11	40
RSS300.815.300	300	75	815	515	300	364	36	10	55	28	100	245	859	M10	11	58
RSS300.815.400	300	75	815	415	400	364	36	10	55	28	100	245	859	M10	11	31
RSS300.915.400	300	75	915	515	400	364	36	10	55	28	100	245	959	M10	11	49

5 Positioning systems

Selection of screw for precision tables RSS/Linear ball bearing table with drive

Preloaded planetary roller screws. Accuracy class G₅ ($v_{300p} = 23 \mu\text{m}$)

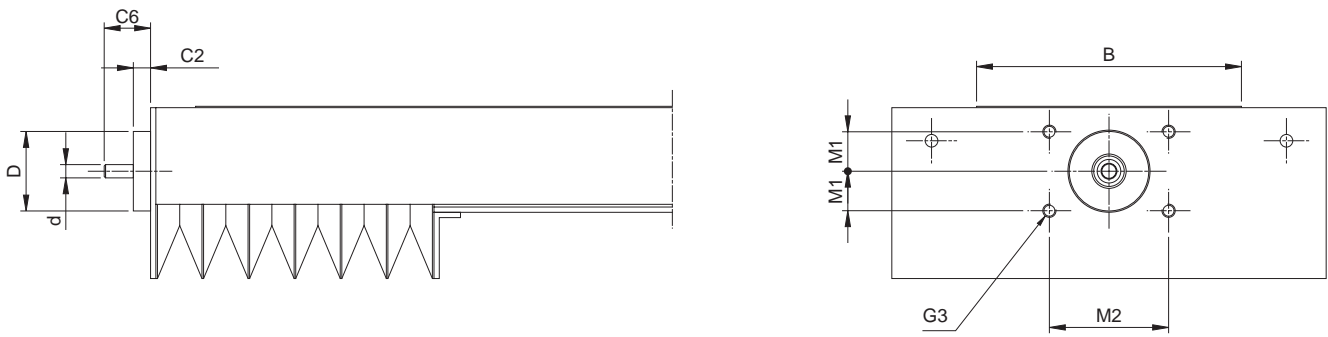

Dimensions	Screw Ø	Lead	Load-carrying capacity ¹⁾		Table driving torque	
			Screw		Idling speed ²⁾	Max. permissible
B	d _o	p	C _a	C _{oa}	M _s	M _a
mm			kN		Nm	
100	R0801	1	3.1	3.0	0.08	0.4
	R0802	2	3.6	4.3	0.09	1.2
	R0804	4	4.4	4.4	0.11	1.5
	R0805	5	4.4	4.2	0.12	1.5
200	R1202	2	3.7	4.6	0.21	1.2
	R1204	4	4.4	4.5	0.23	2.4
	R1205	5	4.8	4.7	0.24	3.1
300	R1502	2	5.5	7.6	0.29	2.0
	R1504	4	6.6	7.4	0.31	3.9
	R1505	5	7.2	7.7	0.32	5.1

¹⁾ With compressive load the screw should be checked for buckling
²⁾ M_s = max. required driving torque at the screw for the unloaded table

Screw type	Stroke	Screw length ³⁾	Max. screw speed	Screw abutment dimensions				
				C ₂	C ₆	G ₃	M ₁	M ₂
	mm	S	min ⁻¹	mm				
R08	50	154	12 000					
	100	195	11 000					
	150	245	6 400	6	17	2 × M5	-	45
	200	295	4 200					
R12	100	220	8 500					
	200	320	6 000					
	300	420	3 200	9	28	4 × M6	15	70
R15	400	520	2 000					
	100	225	6 600					
	200	325	7 300					
	300	425	3 900	9	34	4 × M6	15	70
	400	524	2 400					

³⁾ Total length of screw: for calculation of rotary moment of inertia

Linear ball bearing table with drive

Ordering key

LZ . 230 . 1060 . K 2505

Type

Design:

Open design AB
 Closed design BB

Slide width B [mm]:

See tables

Total length of slide unit L [mm]:

See tables

Screw Ø [mm] - screw lead [mm]:

Screw Ø 12 - screw lead 05	12 05
Screw Ø 16 - screw lead 05	16 05
Screw Ø 20 - screw lead 05	20 05
Screw Ø 25 - screw lead 05	25 05
Screw Ø 25 - screw lead 10	25 10

Example: LZ AB 230 . 1060 . K 2505

5 Positioning systems

Linear ball bearing table

LZBB (on request)

Linear ball bearing slides with closed housing and ball screw

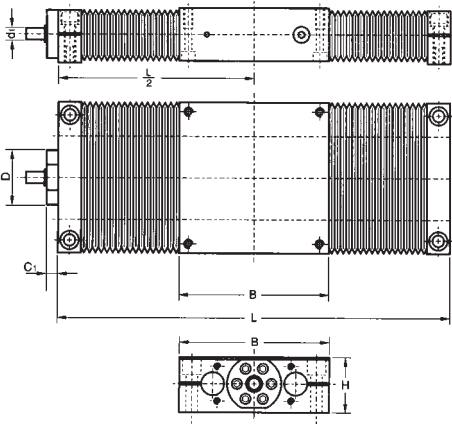

Designations	Dimensions			Nominal stroke*		Screw data			
	B	H	L	S ₁	S ₂	n _{max}	d ₁	D	C ₁
	mm					1/min	mm		
LZBB 100.336.K1205	100	38	336	120	195	5100	6	38	24
LZBB 100.636.K1205	100	38	636	310	495	3450	6	38	24
LZBB 100.936.K1205	100	38	936	495	795	1600	6	38	24
LZBB 100.1236.K1205	100	38	1236	685	1095	920	6	38	24
LZBB 100.1536.K1205	100	38	1536	875	1395	600	6	38	24
LZBB 130.340.K1605	130	48	340	115	165	3800	10	47	28
LZBB 130.640.K1605	130	48	640	330	465	3800	10	47	28
LZBB 130.940.K1605	130	48	940	545	765	2150	10	47	28
LZBB 130.1240.K1605	130	48	1240	755	1065	1250	10	47	28
LZBB 130.1540.K1605	130	48	1540	970	1365	800	10	47	28
LZBB 130.1840.K1605	130	48	1840	1185	1665	560	10	47	28
LZBB 160.410.K2005	160	58	410	145	195	3050	12	55	36
LZBB 160.650.K2005	160	58	650	325	435	3050	12	55	36
LZBB 160.1010.K2005	160	58	1010	595	795	2450	12	55	36
LZBB 160.1250.K2005	160	58	1250	780	1035	1600	12	55	36
LZBB 160.1610.K2005	160	58	1610	1050	1395	960	12	55	36
LZBB 160.1850.K2005	160	58	1850	1230	1635	730	12	55	36
LZBB 180.350.K2005	180	67	350	80	115	3050	12	55	36
LZBB 180.650.K2005	180	67	650	300	415	3050	12	55	36
LZBB 180.950.K2005	180	67	950	515	715	2800	12	55	36
LZBB 180.1250.K2005	180	67	1250	740	1015	1600	12	55	36
LZBB 180.1550.K2005	180	67	1550	960	1315	1050	12	55	36
LZBB 180.1850.K2005	180	67	1850	1175	1615	730	12	55	36
LZBB 180.2150.K2005	180	67	2150	1400	1915	540	12	55	36
LZBB 180.2450.K2005	180	67	2450	1620	2215	420	12	55	36
LZBB 230.460.K2505	230	84	460	120	165	2450	14	68	36
LZBB 230.660.K2505	230	84	660	275	365	2450	14	68	36
LZBB 230.1060.K2505	230	84	1060	580	765	2450	14	68	36
LZBB 230.1260.K2505	230	84	1260	730	965	2050	14	68	36
LZBB 230.1660.K2505	230	84	1660	1035	1365	1200	14	68	36
LZBB 230.1860.K2505	230	84	1860	1185	1565	940	14	68	36
LZBB 230.2260.K2505	230	84	2260	1490	1965	640	14	68	36
LZBB 230.2460.K2505	230	84	2460	1640	2165	540	14	68	36
LZBB 230.2860.K2505	230	84	2860	1945	2565	400	14	68	36
LZBB 230.460.K2510	230	84	460	120	165	2450	14	68	36
LZBB 230.660.K2510	230	84	660	275	365	2450	14	68	36
LZBB 230.1060.K2510	230	84	1060	580	765	2450	14	68	36
LZBB 230.1260.K2510	230	84	1260	730	965	2050	14	68	36
LZBB 230.1660.K2510	230	84	1660	1035	1365	1200	14	68	36
LZBB 230.1860.K2510	230	84	1860	1185	1565	940	14	68	36
LZBB 230.2260.K2510	230	84	2260	1490	1965	640	14	68	36
LZBB 230.2460.K2510	230	84	2460	1640	2165	540	14	68	36
LZBB 230.2860.K2510	230	84	2860	1945	2565	400	14	68	36

* Maximum stroke between end stops: S₁ with bellows (standard version); S₂ without bellows (special version)

LZAB (on request)

Linear ball bearing slides with open housing and ball screw

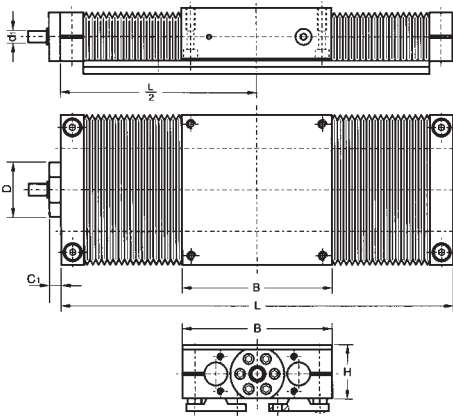

Designations	Dimensions			Nominal stroke*		Screw data			
	B	H	L	S ₁	S ₂	n _{max}	d ₁	D	C ₁
	mm					1/min	mm		
LZAB 100.336.K1205	100	48	336	115	195	5100	6	38	24
LZAB 100.636.K1205	100	48	636	295	495	3450	6	38	24
LZAB 100.936.K1205	100	48	936	475	795	1600	6	38	24
LZAB 100.1236.K1205	100	48	1236	655	1095	920	6	38	24
LZAB 100.1536.K1205	100	48	1536	835	1395	600	6	38	24
LZAB 130.340.K1605	130	57	340	110	165	3800	10	47	28
LZAB 130.640.K1605	130	57	640	320	465	3800	10	47	28
LZAB 130.940.K1605	130	57	940	530	765	2150	10	47	28
LZAB 130.1240.K1605	130	57	1240	740	1065	1250	10	47	28
LZAB 130.1540.K1605	130	57	1540	950	1365	800	10	47	28
LZAB 130.1840.K1605	130	57	1840	1155	1665	560	10	47	28
LZAB 160.410.K2005	160	66	410	140	195	3050	12	55	36
LZAB 160.650.K2005	160	66	650	320	435	3050	12	55	36
LZAB 160.1010.K2005	160	66	1010	585	795	2450	12	55	36
LZAB 160.1250.K2005	160	66	1250	765	1035	1600	12	55	36
LZAB 160.1610.K2005	160	66	1610	1035	1395	960	12	55	36
LZAB 160.1850.K2005	160	66	1850	1210	1635	730	12	55	36
LZAB 180.350.K2005	180	77	350	85	115	3050	12	55	36
LZAB 180.650.K2005	180	77	650	320	415	3050	12	55	36
LZAB 180.950.K2005	180	77	950	550	715	2800	12	55	36
LZAB 180.1250.K2005	180	77	1250	785	1015	1600	12	55	36
LZAB 180.1550.K2005	180	77	1550	1020	1315	1050	12	55	36
LZAB 180.1850.K2005	180	77	1850	1250	1615	730	12	55	36
LZAB 180.2150.K2005	180	77	2150	1485	1915	540	12	55	36
LZAB 180.2450.K2005	180	77	2450	1720	2215	420	12	55	36
LZAB 230.460.K2505	230	95	460	120	165	2450	14	68	36
LZAB 230.660.K2505	230	95	660	275	365	2450	14	68	36
LZAB 230.1060.K2505	230	95	1060	580	765	2450	14	68	36
LZAB 230.1260.K2505	230	95	1260	730	965	2050	14	68	36
LZAB 230.1660.K2505	230	95	1660	1035	1365	1200	14	68	36
LZAB 230.1860.K2505	230	95	1860	1185	1565	940	14	68	36
LZAB 230.2260.K2505	230	95	2260	1490	1965	640	14	68	36
LZAB 230.2460.K2505	230	95	2460	1640	2165	540	14	68	36
LZAB 230.2860.K2505	230	95	2860	1945	2565	400	14	68	36
LZAB 230.460.K2510	230	95	460	120	365	2450	14	68	36
LZAB 230.660.K2510	230	95	660	275	365	2450	14	68	36
LZAB 230.1060.K2510	230	95	1060	580	765	2450	14	68	36
LZAB 230.1260.K2510	230	95	1260	730	965	2050	14	68	36
LZAB 230.1660.K2510	230	95	1660	1035	1365	1200	14	68	36
LZAB 230.1860.K2510	230	95	1860	1185	1565	940	14	68	36
LZAB 230.2260.K2510	230	95	2260	1490	1965	640	14	68	36
LZAB 230.2460.K2510	230	95	2460	1640	2165	540	14	68	36
LZAB 230.2860.K2510	230	95	2860	1945	2565	400	14	68	36

* Maximum stroke between end stops: S₁ with bellows (standard version); S₂ without bellows (special version)

5 Positioning systems

Linear axes, type PICO

LTP

Ordering key

	LTP	60	230	0804	00
Type					
Width:	60 - 80				
Length of axis [mm]:					
Screw Ø [mm] - screw lead [mm]:					
Screw Ø 08 - screw lead 04 (for width = 60)					0804
Screw Ø 12 - screw lead 05 (for width = 80)					1205
Screw Ø 12 - screw lead 10 (for width = 80)					1210
Flange and coupling					
For 2-ph. stepping motor					00
For Ecostep [®] motor					01
For AC Servo motor					02

Example: **LTP** **60** . **230** . **0804** - **00**

NB:

3-step files of all standard axes are available upon request.

Technical informations

Load carrying capacity of axes

Designation	Load carrying capacity of axes		Static moments ¹⁾			Moment of inertia	
	C	C _o	M _{ox} ²⁾	M _{oy} ²⁾	M _{oz} ²⁾	I _z	I _y
	N	N	Nm	Nm	Nm	mm ⁴	mm ⁴
LTP60	4150	8000	95.6	55.8	55.8	55510	365 900
LTP80	5830	10600	225.0	94.1	108.0	96430	892 300

¹⁾ Moments apply to pure moment load (no additional linear load)
²⁾ Designation of moments, see Table of dimensions

5

Load carrying capacity of drive

Designation	Screw type				Load carrying capacity ¹⁾ of drive		Table drive torque	
	Nominal Ø	Lead	Lead accuracy		Dynamic	Static	Idling	Max. permissible
	d _o	p	V _{300p}		C _a	C _{oa}	M _s	M _a
	mm	mm	-	µm/300mm	N	N	Nm	Nm
LTP60	8	4	G7	50	2000	1000	0.03	0.7
LTP80	12	5	G7	50	3500	1300	0.04	1.1
LTP80	12	10	G7	50	2800	1300	0.04	2.2

¹⁾ Value indicated = minimum load rating of either screw or locating bearing

Designation	Dimension			Stroke ¹⁾ S	Mass	Screw data				
	L ₁	L ₃	n			d _o	p	I _{red} ²⁾	a _{max}	n _{max}
	mm	mm	-	mm	kg	mm	mm	kgmm ²	m/s ²	1/min
LTP60.130.0804-XX	130	38	1	60	1.3	8	4	2.7	3.2	4500
LTP60.180.0804-XX	180	9	3	110	1.5	8	4	2.8	3.2	4500
LTP60.230.0804-XX	230	34	3	160	1.7	8	4	3.0	3.2	4500
LTP60.280.0804-XX	280	59	3	210	1.9	8	4	3.1	3.2	4500
LTP60.330.0804-XX	330	30	5	260	2.1	8	4	3.3	3.2	4500
LTP80.250.1205-XX	250	14	3	160	3.4	12	5	7.2	4.0	4500
LTP80.350.1205-XX	350	64	3	260	4.1	12	5	8.8	4.0	4500
LTP80.450.1205-XX	450	40	5	360	4.7	12	5	10.4	4.0	4500
LTP80.550.1205-XX	550	16	7	460	5.4	12	5	12.0	4.0	4500
LTP80.650.1205-XX	650	66	7	560	6.1	12	5	13.6	4.0	4500
LTP80.250.1210-XX	250	14	3	160	3.4	12	10	8.5	8.0	4500
LTP80.350.1210-XX	350	64	3	260	4.1	12	10	10.1	8.0	4500
LTP80.450.1210-XX	450	40	5	360	4.7	12	10	11.7	8.0	4500
LTP80.550.1210-XX	550	16	7	460	5.4	12	10	13.3	8.0	4500
LTP80.650.1210-XX	650	66	7	560	6.1	12	10	14.9	8.0	4500

¹⁾ Max. stroke between limit switches
²⁾ Red. moment of inertia (screw, coupling, slide moving part)

Designation	Size		Motor flange and coupling			
	A	M	D	d	d _{max} ¹⁾	l
	mm	-	mm	mm	mm	mm
LTP60.xxx.xxxx-00 ²⁾	47,2	M4	38,2	6,35	13	30
LTP60.xxx.xxxx-01	47,2	M4	38,2	8,00	13	30
LTP60.xxx.xxxx-02	44,6	M5	40,0	9,00	13	30
LTP80.xxx.xxxx-00 ²⁾	47,2	M4	38,2	6,35	13	30
LTP80.xxx.xxxx-01	47,2	M4	38,2	8,00	13	30
LTP80.xxx.xxxx-02	44,6	M5	40,0	9,00	13	30

¹⁾ Coupling can be reworked to dmax
²⁾ Flange dimensions according to NEMA 23

5 Positioning systems

Linear axes, type PICO - Drive concepts

Drive concepts

Stepper motor drive

Note: Drive forces are based on nominal motor torques (SM56.1.18.J3 for LTP60, SM56.2.18.J3 for LTP80) as well as lead, idling torque, efficiency and guiding friction of the screw. There is a risk of step losses

when exceeding the indicated forces. 60 V version upon request.

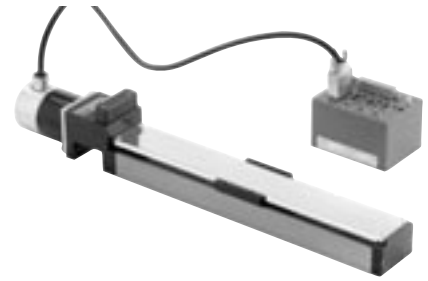

Drive force and speed

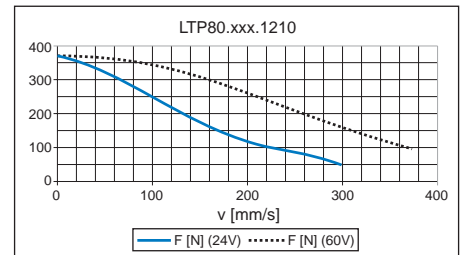
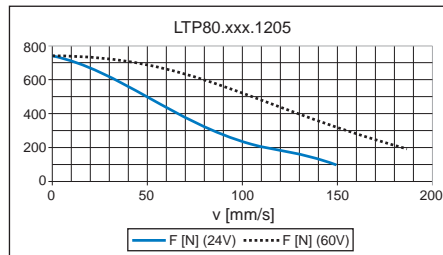
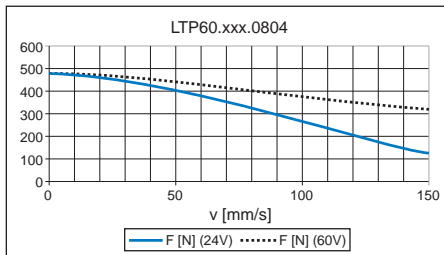

Type	Length		Height	Weight		Brake force ¹⁾ F _b	Step size
	Motor	Brake		Motor	Brake		
	mm			kg		N	μm
LTP60.xxx.0804	+ 68	+ 35	93	0.6	0.3	1000	20
LTP80.xxx.1205	+ 94	+ 35	94	1.0	0.3	1220	25
LTP80.xxx.1210	+ 94	+ 35	94	1.0	0.3	610	50

¹⁾ LTP60: the brake force is limited by the maximum allowed axial load capacity of the spindle.

Control unit data

- Programmable control unit with 18 motion profiles
- Digital current, speed and position control
- Operating voltage 24 or 60 VDC
- Adjustable motor current
- Command value input via CANopen, RS485 or Profibus interface
- 3 digital inputs, 3 digital outputs, freely usable
- Configured for motor and limit switches
- Attachment on mounting plate
- Dimensions 100 × 70 × 60 mm (H×W×D)
- Standard cable length 2 m
- Including software

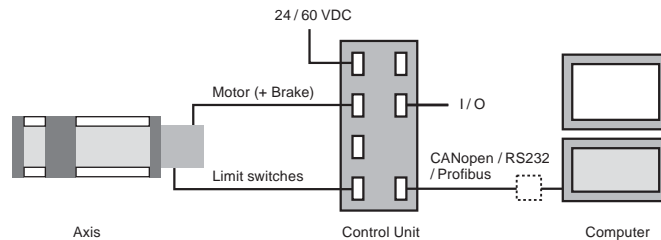

Ecostep® Servo drive

Note: Drive forces are based on nominal motor torques (23S16 for LTP60, 23S21 for LTP80) as well as lead, idling torque, efficiency and guiding friction of the screw. The indicated values represent the maximum permissible forces.

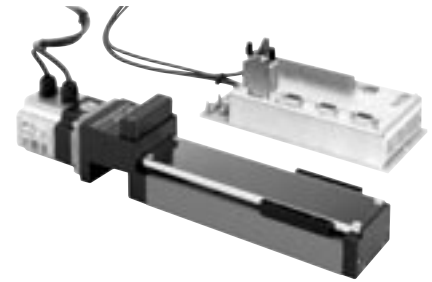

Drive force and speed

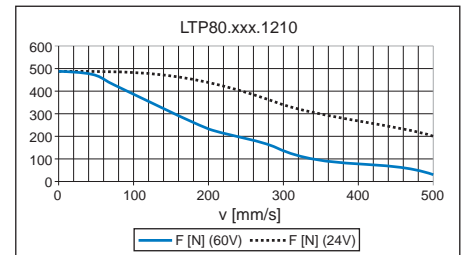
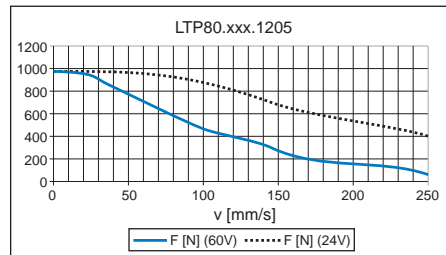
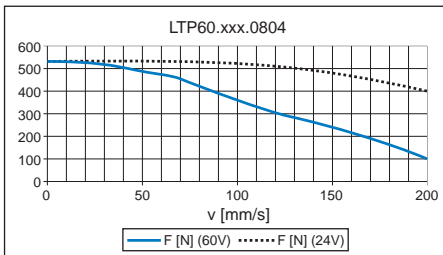

5

Type	Lenght		Height	Weight		Brake force ¹⁾ F _b
	Motor	Brake		Motor	Brake	
	mm			kg		N
LTP60.xxx.0804	+ 73	+ 35	93	0.5	0.3	1000
LTP80.xxx.1205	+ 88	+ 35	94	0.8	0.3	860
LTP80.xxx.1210	+ 88	+ 35	94	0.8	0.3	430

¹⁾ LTP60: the brake force is limited by the maximum allowed axial load capacity of the spindle.

Control unit data

- Programmable control unit with 256 motion profiles
- Digital current, speed and position control
- Adjustable motor current
- Operating voltage from 24 to 70 VDC
- Command value input via analog ± 10 V, CANopen or RS232 interface
- 6 digital inputs, 2 digital outputs, freely useable
- Configured for motor and limit switches
- Dimensions 200 × 87 × 50 mm (H×W×D)
- Standard cable length 2 m
- Including software

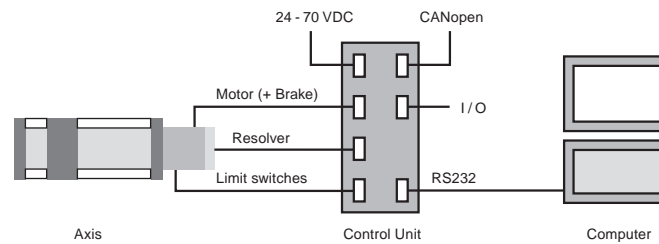

5 Positioning systems

Linear axes, type PICO - Drive concepts/Profile rail guide slides

AC-Servo drive

Note: Drive forces are based on nominal motor torques (DBL2 H00040 for LTP60, DBL2 H00080 for LTP80) as well as lead, idling torque, efficiency and guiding friction of the screw. The indicated forces are related to 100% duty cycle. Short-time

overload permissible up to axial load rating (C_{0a}) of the screw.



Drive force and speed

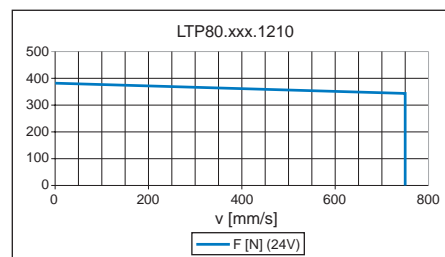
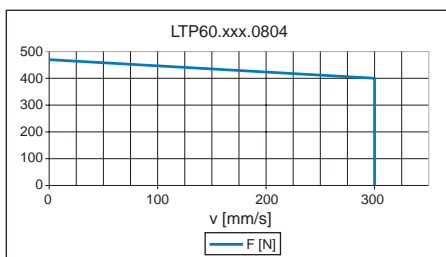

Type	Length		Height	Weight		Brake force ¹⁾ F _b
	Motor	Brake		Motor	Brake	
	mm			kg		N
LTP60.xxx.0804	+ 73	+ 35	93	1.1	0.3	1000
LTP80.xxx.1205	+ 88	+ 35	94	1.5	0.3	1300
LTP80.xxx.1210	+ 88	+ 35	94	1.5	0.3	940

¹⁾ LTP60 and LTP80.xxx.1205: the brake force is limited by the maximum allowed axial load capacity of the spindle.

Control unit data

- Programmable control unit with 256 motion profiles
- Digital current, speed and position control
- Adjustable motor current
- Operating voltage 230 VAC, auxiliary voltage 24 VDC
- Command value input via ± 10 V analog, CANopen or RS232 interface; Profibus fieldbus as option
- 2 digital inputs, 2 digital outputs, freely usable
- Configured for motor and limit switches
- Mounting on cap rail
- Dimensions 245 × 100 × 225 mm (H×W×D)
- Standard cable length 5 m
- Including user-friendly software

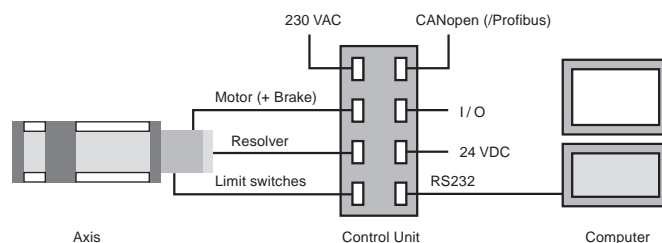

5 Positioning systems

Profile rail guide slides

LTB with screw drive

SKF profile rail slides are state-of-the-art systems that offer high load-carrying capacity and accuracy.

They are available in five sizes:

110 – 170 – 235 – 320 – 400

with two drives:

ball screws – linear motors

with three covers:

without cover – with bellows – with steel cover

cover

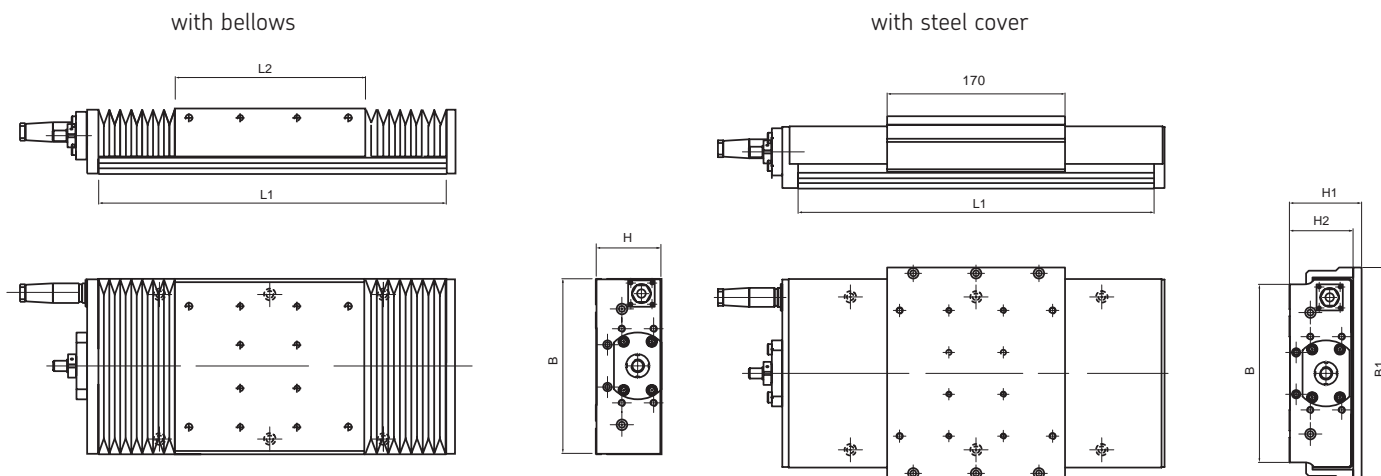

Designations	Dimensions							Stroke		3) F_{oz}	F_{oy}	4)			Screw Pitch		5) C_{oa}						
	B	B_1	H	H_1	H_2	L_1	L_2	1) S_1	2) S_2			M_{ox}	M_{oy}	M_{oz}	\emptyset	p		kN					
	mm																		kN		kNm		
LTB 110	110	122	40	47	41	150	110	20	30	17.1	8.5	0.69	0.58	0.29	12	5 ... 10	3.5 ... 7.1						
																			
						950		505	830														
LTB 170	170	202	60	69	61	220	170	35	40	54	27	3.10	2.5	1.20	16	5 ... 16	6.4 ... 12.7						
																			
						1600		1085	1420														
LTB 235	235	275	85	97	87	280	235	35	35	97.6	48.8	7.60	6.8	3.40	25	5 ... 25	11.2 ... 31.0						
																			
						2860		2195	2615														
LTB 320	320	365	115	138	118	580	350	195	220	121.6	60.8	13.40	13.4	6.70	32	5 ... 40	20.5 ... 55.0						
																			
						2860		2180	2500														
LTB 400	400	-	135	-	-	620	450	145	160	216	108	29.20	29.2	14.60	40	5 ... 40	35.1 ... 64.0						
																			
						2860		2135	2400														

1) Maximum stroke between end stops, with bellows

2) Maximum stroke between end stops, with steel cover

3) Maximum static load per table in X and Y

4) Maximum static moments in X, Y and Z

5) Maximum static load per screw

LTB with linear motor drive

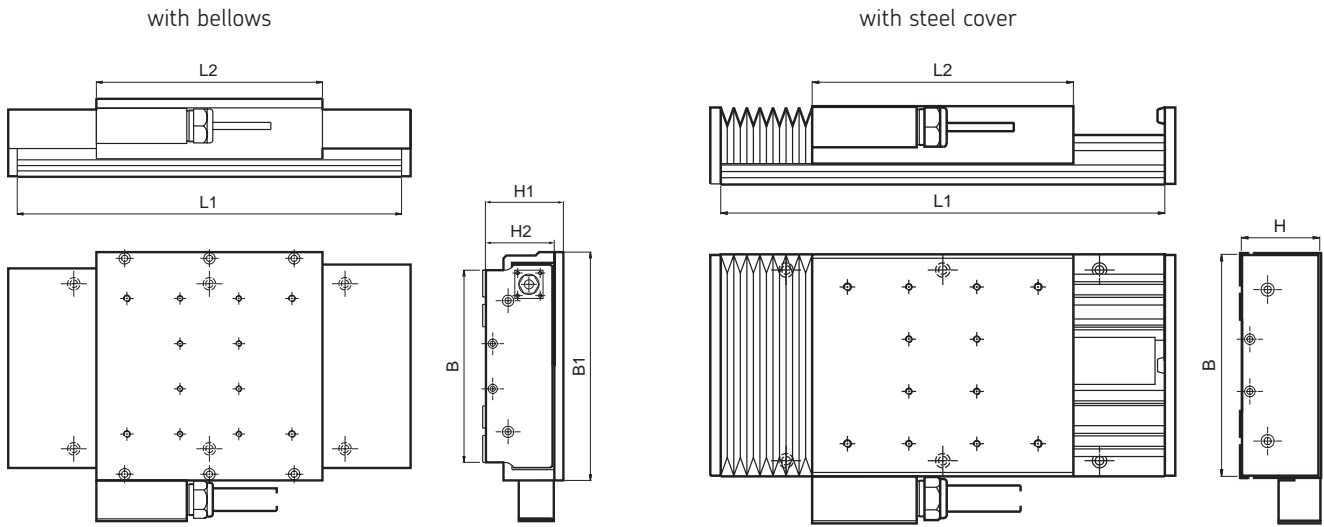

Designations	Dimensions					L ₁	L ₂	Stroke S ₁	1) S ₂	2) F _{oz}	Motor Size	3) F _p
	B	B ₁	H	H ₁	H ₂							
	mm											
LTB 110	110	123	40	49	43	150	110	20	30	16.9	F20906	105
	950	...	505	830
	230	190	20	30	16.9	F21806	210					
	950	...	455	750
	350	280	40	60	25.0	F22706	315					
...	950	...	405	660	
LTB 170	170	202	60	69	61	280	200	55	70	53.6	F21806	210
	1600	...	1065	1390
	340	280	40	50	53.4	F22706	315					
	1600	...	1000	1310
LTB 235	235	275	85	97	87	340	235	25	95	95.8	A32008	600
	2860	...	2195	2615
	320	...	45	70	94.9	A33008	900					
	2860	...	2125	2530
	410	...	75	100	94.0	A34008	1200					
...	2860	...	2050	2440	
LTB 320	320	365	110	133	113	580	280	260	290	118.0	A32014	1200
	2860	...	2235	2570
	580	320	225	250	116.0	A33014	1800					
	2860	...	2200	2530
	580	410	135	160	114.0	A34014	2400					
...	2860	...	2125	2440	

1) Maximum stroke between end stops: S₁ with bellows; S₂ without bellows or with steel cover

2) F_{oz} is the maximum static load per table

3) F_p is static maximum force (2 to 3s)

5 Positioning systems

Profile rail guide slides, preferred range

LTB

SKF profile rail guide slides LTB of the preferred range are a price-efficient

alternative to the in-house production. The LTB preferred range shows 2 widths in 3 lengths each and can be delivered in 2 working weeks. The slides are equipped

with preloaded profile rails and preloaded ball screw, with bellows covers, end switches and motor coupling.

LTB170.L1.TN1605-BL-P2/V

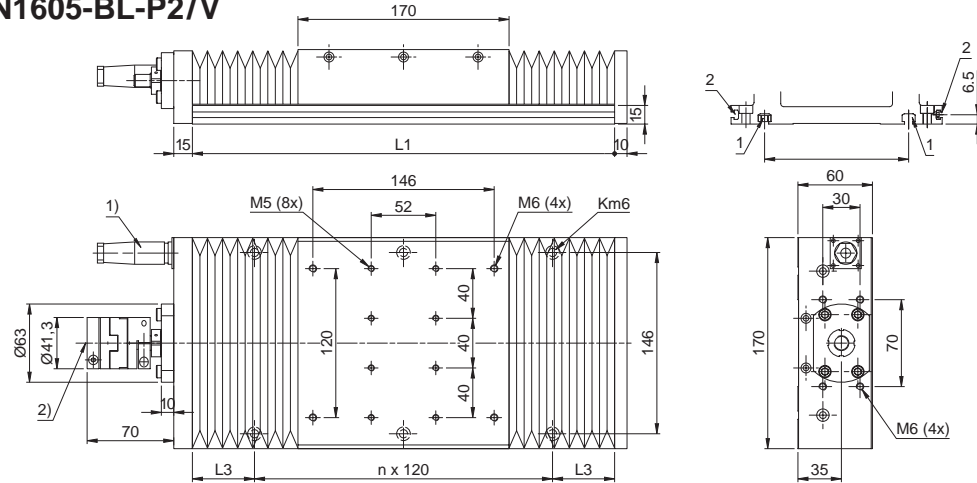

LTB235.L1.TN2505-BL-P2/V

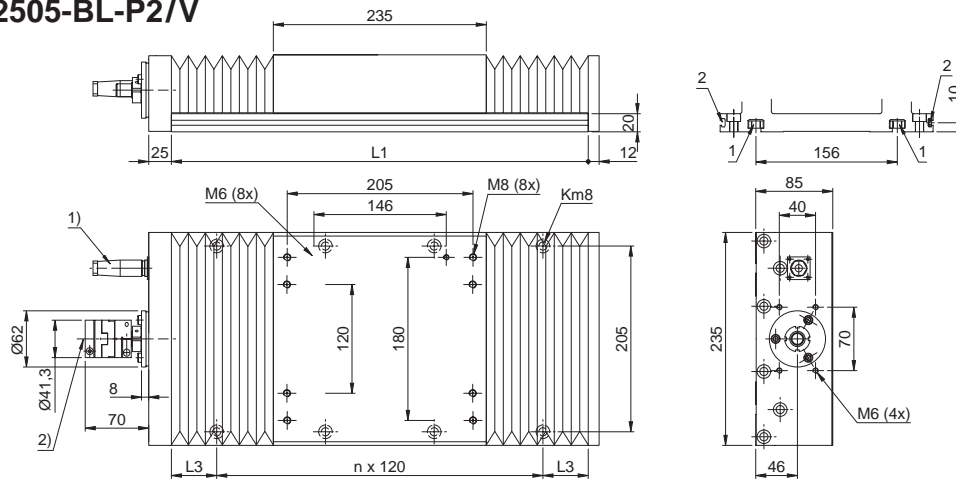

Designation	Dimension		Stroke ¹⁾		Weight	Screw data		
	L ₁	L ₃	S	n		d _o	p	n _{max}
	mm			-	kg	mm		1/min
LTB170.340.TN1605-BL-P2/V	340	50	105	2	7.1	16	5	5620
LTB170.520.TN1605-BL-P2/V	520	20	240	4	9.2	16	5	5620
LTB170.700.TN1605-BL-P2/V	700	50	380	5	11.3	16	5	5620
LTB235.520.TN2505-BL-P2/V	520	20	215	4	20.0	25	5	3600
LTB235.700.TN2505-BL-P2/V	700	50	365	5	24.1	25	5	3600
LTB235.880.TN2505-BL-P2/V	880	20	515	7	28.1	25	5	3600

¹⁾ Max. stroke between limit switches



Union means strength.

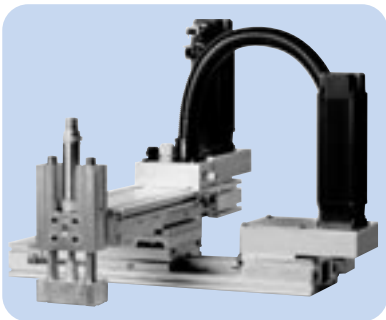

Bees represent what is probably the most eloquent example of a society within the natural world. They exhibit a primordial model of social caste with subdivision of role, as well as full control over defence, labour and even reproduction.

Small organisational wonders of this kind have provided inspiration to SKF in the creation of solutions which transcend single components, resulting in complete units and systems incorporating a wide range of products, to meet the requirements of each individual customer.

With SKF, even the smallest things become great.

Linear motion from SKF
www.linearmotion.skf.com







SKF – The knowledge engineering company

The business of the SKF Group consists of the design, manufacture and marketing of the world's leading brand of rolling bearings, with a global leadership position in complementary products such as radial seals. SKF also holds an increasingly important position in the market for linear motion products, high precision aerospace bearings, machine tool spindles, plant maintenance services and is an established producer of high-quality bearing steel.

The SKF Group maintains specialized businesses to meet the needs of the global marketplace. SKF supports specific market segments with ongoing research and development efforts that have led to a growing number of innovations, new standards and new products.

SKF Group has global ISO 14001 environmental certification. Individual divisions have been approved for quality certification in accordance with either ISO 9000 or appropriate industry specific standards.

Some 80 manufacturing sites worldwide and sales companies in 70 countries make SKF a truly international corporation. In addition, our 7 000 distributor and dealer partners around the world, e-business marketplace and global distribution system put SKF close to customers for the supply of both products and services. In essence, SKF solutions are available wherever and whenever our customers need them.

Overall, the SKF brand now stands for more than ever before. It stands for the knowledge engineering company ready to serve you with world-class product competences, intellectual resources and the vision to help you succeed.



Harnessing wind power

The growing industry of wind-generated electric power provides an environmentally compatible source of electricity. SKF is working closely with global industry leaders to develop efficient and trouble-free turbines, using SKF knowledge to provide highly specialized bearings and condition monitoring systems to extend equipment life in the extreme and often remote environments of wind farms.

Developing a cleaner cleaner

The electric motor and its bearings are the heart of many household appliances. SKF works closely with appliance manufacturers to improve their product's performance, cut costs and reduce weight. A recent



example produced a new generation of vacuum cleaners with substantially more suction. SKF's knowledge in small bearing technology is also applied to manufacturers of power tools and office equipment.



Delivering asset efficiency optimization

To optimize efficiency and boost productivity, many industrial facilities outsource some or all of their maintenance services to SKF, often with guaranteed performance contracts. Through the specialized capabilities and knowledge available from SKF Reliability

Systems, SKF provides a comprehensive range of asset efficiency services, from maintenance strategies and engineering assistance, to operator-driven reliability and machine maintenance programs.



Creating a new “cold remedy”

In the frigid winters of northern China, sub-zero temperatures can cause rail car wheel assemblies and their bearings to seize due to lubrication starvation. SKF created a new family of synthetic lubricants formulated to retain their lubrication viscosity even at these extreme bearing temperatures. SKF's knowledge of lubricants and friction are unmatched throughout the world.



Planning for sustainable growth

By their very nature, bearings make a positive contribution to the natural environment. Reduced friction enables machinery to operate more efficiently, consume less power and require less lubrication. SKF is continually raising the performance bar, enabling new generations of high-efficiency products and equipment. With an eye to the future, SKF's global policies and manufacturing techniques are planned and implemented to help protect and preserve the earth's limited natural resources. We remain committed to sustainable, environmentally responsible growth.

Evolving by-wire technology

SKF has unique expertise and knowledge in fast growing by-wire technology, from fly-by-wire, to drive-by-wire, to work-by-wire. SKF pioneered practical fly-by-wire technology and is a close working partner with all aerospace industry leaders. As an example, virtually all aircraft of the Airbus design use SKF by-wire systems for cockpit

flight control. SKF is also a leader in automotive drive-by-wire, having jointly developed the revolutionary Filo and Novanta concept cars which employ SKF mechatronics for steering and braking. Further by-wire development has led SKF to produce an allelectric forklift truck which uses mechatronics rather than hydraulics for all controls.



Maintaining a 320 km/h R&D lab

In addition to SKF's renowned research and development facilities in Europe and the United States, Formula One car racing provides a unique environment for SKF to push the limits of bearing technology. For over 50 years, SKF products, engineering and knowledge have helped make

Scuderia Ferrari a formidable force in F1 racing. (The average racing Ferrari utilizes more than 150 SKF components.) Lessons learned here are applied to the products we provide to automakers and the aftermarket worldwide.

Contacts

Linear motion from SKF www.linearmotion.skf.com

Benelux

SKF Multitec Benelux B.V.

Nederland

Tel +31 (0) 30 6 029 029

Fax +31 (0) 30 6 029 028

België & Luxembourg

Tel +32 (0) 2 5 024 270

Fax +32 (0) 2 5 027 336

E-mail multitec_benelux@skf.com

Danmark

SKF Multitec

Tel +45 65 92 77 77

Fax +45 65 92 74 77

E-mail customerservice.multitec@skf.com

Deutschland

SKF Linearsysteme GmbH

Tel +49 (0) 9721 657 232 / 233

Fax +49 (0) 9721 657 111

E-mail lin.sales@skf.com

España & Portugal

SKF Productos Industriales S.A.

Tel +34 93 377 99 77 / 07

Fax +34 93 474 20 39

E-mail prod.ind@skf.com

France

SKF Equipements

Tel +33 (0) 1 30 12 73 00

Fax +33 (0) 1 30 12 69 09

E-mail equipements.france@skf.com

Italia

SKF Multitec S.p.A.

Tel +39 011 22 49 01

Fax +39 011 22 49 233

E-mail multitec.italy@skf.com

Norge

SKF Multitec

Tel +47 22 90 50 00

Fax +47 22 30 28 14

E-mail customerservice.multitec@skf.com

Schweiz

SKF Linear Motion

Tel +41 1 825 81 81

Fax +41 1 825 82 82

E-mail skf.schweiz@skf.com

Suomi

SKF Multitec

Tel +358 9 615 00 850

Fax +358 9 615 00 851

E-mail customerservice.multitec@skf.com

Sverige

SKF Multitec

Tel +46 42 25 35 00

Fax +46 42 25 35 45

E-mail customerservice.multitec@skf.com

U.K.

SKF Engineering Products Ltd.

Tel +44 (0) 1582 496735

Fax +44 (0) 1582 496574

E-mail skf.epl@skf.com

USA & Canada/South America

SKF Motion Technologies

Tel +1 610 861 4800

Toll free +1 800 541 3624

Fax +1 610 861 4811

E-mail motiontech.usa@skf.com

Österreich

Linear Motion

SKF Österreich AG

Tel +43 (0) 2236 6709 0

Fax +43 (0) 2236 6709 220

E-mail multitec.austria@skf.com

Other countries

Actuation systems

Fax +41 61 921 37 04

E-mail actuators@skf.com

Driving systems

Fax +41 61 921 37 04

E-mail brs@skf.com

Guiding & Positioning systems

Fax +41 61 921 37 04

E-mail guidings@skf.com



Linear motion from SKF
www.linearmotion.skf.com



Represented by:

Copy price: 10 €

© SKF is a registered trademark of the SKF Group.

© SKF 2005

The contents of this publication are the copyright of the publisher and may not be reproduced (even extracts) unless prior written permission is granted. Every care has been taken to ensure the accuracy of the information contained in this publication but no liability can be accepted for any loss or damage whether direct, indirect or consequential arising out of the use of the information contained herein.

Publication 4664/5 EN

Printed in Italy