

Ball Rail® Tables TTK

STAR – Linear Motion Technology

Ball Rail® Systems

Standard Ball Rail Systems
Ball Rail Systems with Aluminum Runner Blocks
Super Ball Rail Systems
Wide Ball Rail Systems
Accessories
Miniature Ball Rail Systems
Cam Roller Guides

Roller Rail Systems

Linear Bushings and Shafts

Linear Bushings
Linear Sets
Shafts
Shaft Support Rails
Shaft Support Blocks
Ball Transfer Units
Other Engineering Components

Screw Drives

Linear Motion Systems

Linear Motion Slides

- Ball Screw Drive
- Toothed Belt Drive

Linear Modules

- Ball Screw Drive
- Toothed Belt Drive
- Rack and Pinion Drive
- Linear Motor
- Pneumatic Drive

Compact Modules

- Ball Screw Drive

Precision Modules

- Ball Screw Drive

Ball Rail® Tables

- Ball Screw Drive
- Linear Motor

Super Structure™ Profile System
Controllers, Motors, Electrical Accessories

STAR – Ball Rail Tables TKK

| | |
|---|-----------|
| A Solution to Many Problems | 4 |
| Product Overview | 6 |
| – Motor Preselection | 8 |
| – Type Designation, Sizes | 10 |
| – Structure | 12 |
| Mounting, Accuracy | 14 |
| Technical Data | 16 |
| – General system data | 16 |
| – Permissible speeds | 18 |
| – Permissible drive torque, fixed bearing end | 19 |
| – Drive data of the side drive with timing belt, floating bearing end | 20 |
| – Technical data AC servomotors | 20 |
| Calculation Information | 22 |
| – Formulas | 22 |
| – Calculation example | 24 |
| Options Table, Dimension Drawings | 26 |
| – TKK 15-155 Al | 26 |
| – TKK 20-225 Al | 32 |
| – TKK 20-225 St | 36 |
| – TKK 30-325 Al | 42 |
| – TKK 30-325 St | 46 |
| – TKK 35-455 Al | 52 |
| Switch Mounting Arrangements, Accessories | 58 |
| – Overview of switching system | 58 |
| – Motors | 60 |
| – Documentation | 62 |
| – Mounting accessories | 65 |
| Connection System | 66 |
| Request for Quotation/Order Form | 72 |

STAR – Ball Rail® Tables TKK

A Solution to Many Problems

The tasks

- Driving
- Transporting
- Positioning

Length

Load capacities and moments

Static load capacity

Speed

Precision

System complete
with drive unit

Switch mounting arrangements

Multiple axis unit

Accessories

Documentation

Up to 2860 mm

Load capacity C up to 132500 N
Pitch and yaw moment M_L up to 18100 Nm
Roll moment M_t up to 19800 Nm

Up to 2500 kg

Up to 96 m/min

| | |
|----------------------------|----------|
| Repeatability up to | 0.005 mm |
| Positioning accuracy up to | 0.01 mm |
| Straightness up to within | 0.007 mm |

AC servo motor or minidrive
with mount and coupling or side drive with
timing belt

Mechanical and
proximity switches

Combination available with
connectors

T-nuts, etc.

Moment of friction measurement
Lead deviation
Travel accuracy
Positioning accuracy

The solution

**STAR –
Ball Rail Tables**

STAR – Ball Rail® Tables TKK

Product Overview

STAR Ball Rail Tables are precision, ready-to-mount components with high performance characteristics and compact dimensions.

Practical combination options and the modular construction principle make a wide range of economical applications possible.

Rapid delivery is a matter of course.

Structure

- Base plate made from precision machined aluminum or steel profile with reference edge in finely graduated length increments
- Guideway: Two STAR Ball Rail Systems with four long runner blocks per carriage
- STAR Precision Ball Screw Assemblies to tolerance class 7 with zero backlash nut systems
- Aluminum fixed bearing end-plates with two-row preloaded angular contact ball bearing
- Floating bearing end-plates with double floating bearing system
- Carriage made of machined aluminum or steel profiles in various lengths

Accessories

- Bellows
- Internal glass scale
- Internal or external mechanical switch
- Internal or external proximity switch
- Socket with mating plug for the switches
- Aluminum profile cable duct
- Side drive with timing belt or motor mount and coupling for attachment of the motor
- Maintenance-free digital AC servomotors with integrated brake and attached feedback

Drive controllers and control systems



For mounting and maintenance please refer to "Instructions for Ball Rail Tables TKK" RDEFI 82 571

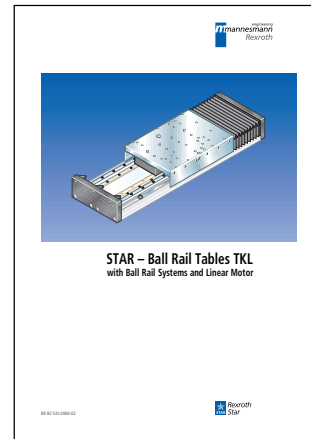

New: Ball Rail Tables with two Ball Rail Systems and linear motor RE 82 531

▶ Oil and temperature resistant bellows mounting provided by mechanical clamping of the last folds.

▶ Simple motor attachment due to pilot bore and tapped mounting holes.

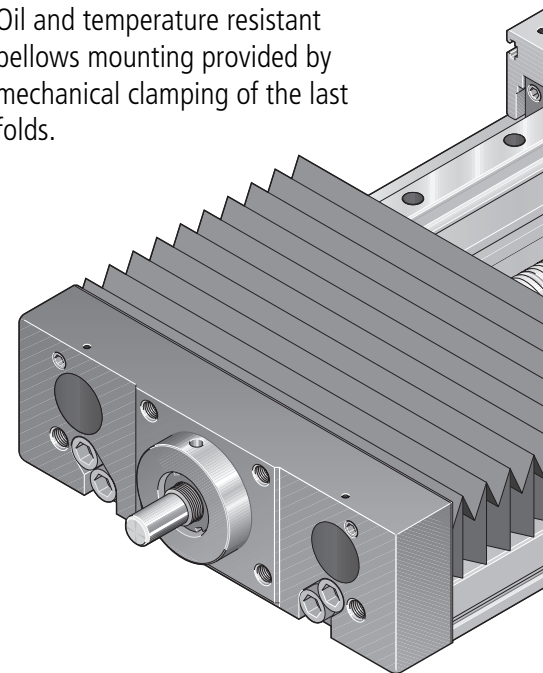

▶ High speeds over long distances are possible by using the combination of STAR Ball Rail Systems, and STAR Ball Screws which offer large diameters and leads, and double floating bearing systems.

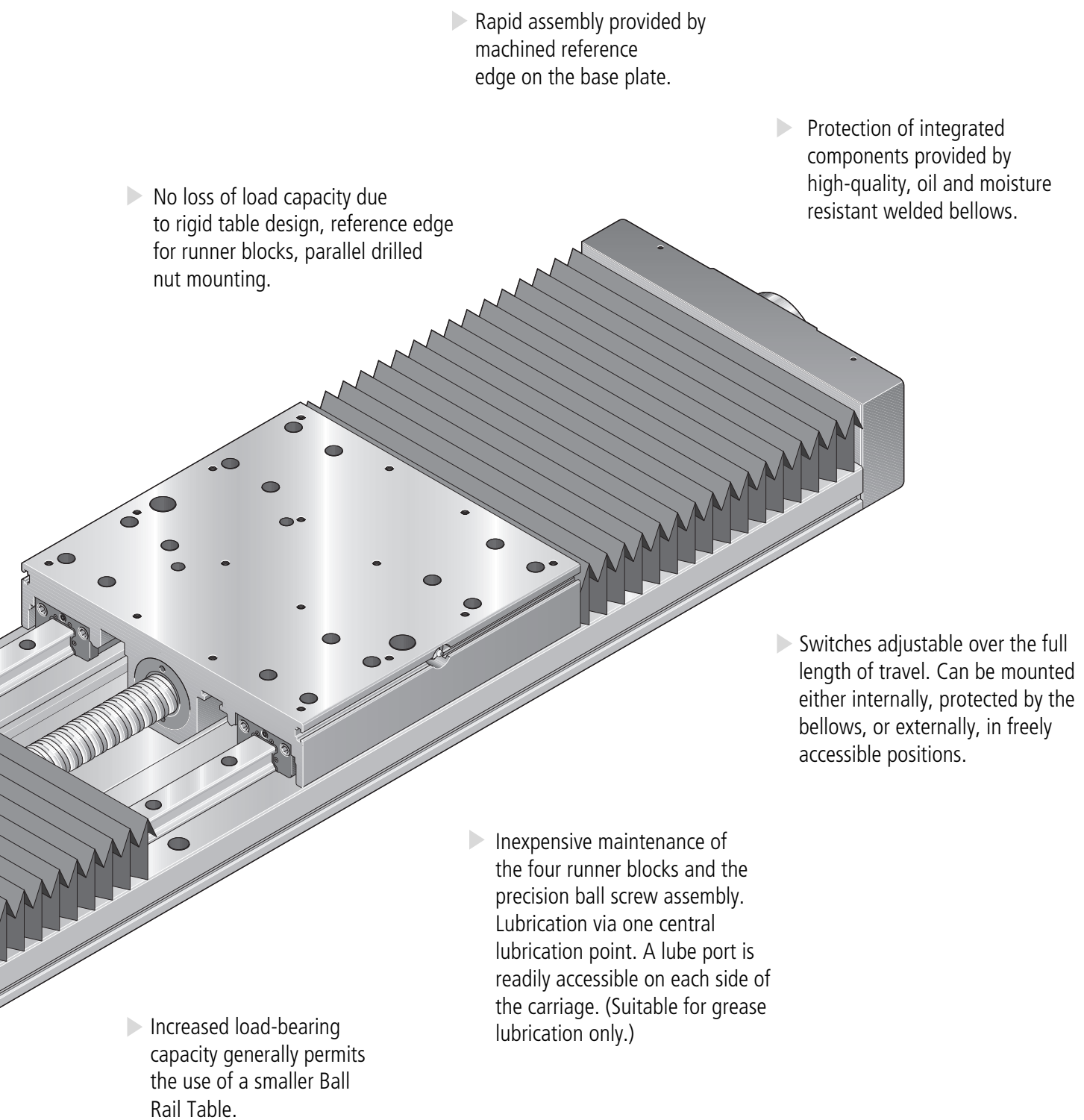

▶ Rapid assembly provided by machined reference edge on the base plate.

▶ No loss of load capacity due to rigid table design, reference edge for runner blocks, parallel drilled nut mounting.

▶ Protection of integrated components provided by high-quality, oil and moisture resistant welded bellows.

▶ Switches adjustable over the full length of travel. Can be mounted either internally, protected by the bellows, or externally, in freely accessible positions.

▶ Inexpensive maintenance of the four runner blocks and the precision ball screw assembly. Lubrication via one central lubrication point. A lube port is readily accessible on each side of the carriage. (Suitable for grease lubrication only.)

▶ Increased load-bearing capacity generally permits the use of a smaller Ball Rail Table.

STAR – Ball Rail® Tables TKK

Product Overview

Motor preselection

in accordance with controllers and control systems

A choice can be made between several different motor/controller combinations to achieve the most cost-efficient solution for each application.

The motor/controller combination must always be considered when sizing the drive.

For more detailed information on motors and control systems, please refer to catalog RE 82 701 "Controllers, Motors, Electrical Accessories".

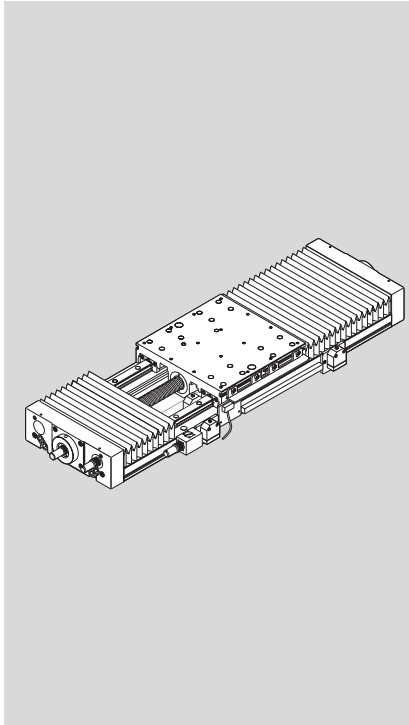

Digital AC servomotors

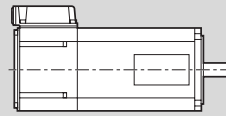

MKD
MHD

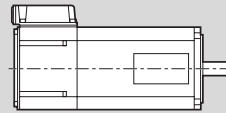

MKD

MiniDrive

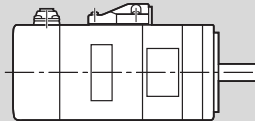

MMD 082A



DKC

Digital controller
The low-cost solution for single-axis and multi-axis systems

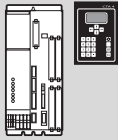

DKS

Digital positioning module and DLC controls
The universal solution for one axis

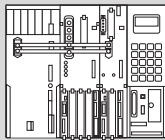

DDS

Digital controllers and CLM analog positioning module
The convenient solution for multi-axis systems

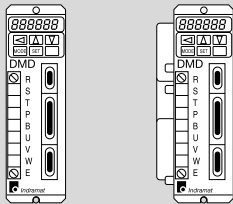

DMD

Digital controller



WD3

Power output section
for control cabinet installation

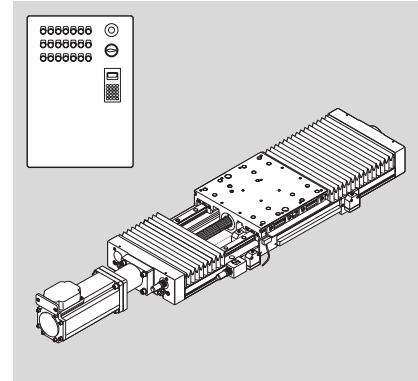

Ball Rail Tables can be supplied complete with motor, controller and control system.

STAR – Ball Rail® Tables TKK

Product Overview

Type designation



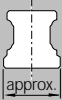
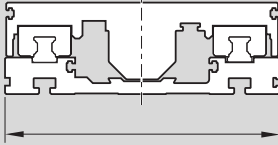

The Ball Rail Tables are designated according to **type** and **size**.

Types also cover the equivalent designs without drive systems.

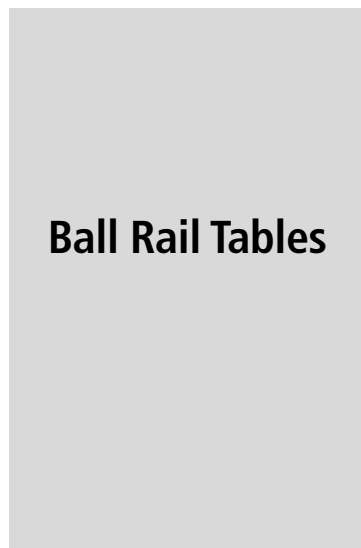
| | | Type | | | Size | |
|------------------------------------|--|------|---|---|--------|----|
| | | T | K | K | 20-225 | Al |
| Ball Rail Table (example) = | | | | | | |
| System | = Ball Rail Table (T) | | | | | |
| Guideway | = Ball Rail System (K) | | | | | |
| Drive unit | = Ball Screw Drive (K) | | | | | |
| Dimensions of guideway | =  | | | | | |
| Frame dimensions | =  | | | | | |
| Material | = <u>Al</u> uminum <u>St</u> eel | | | | | |

Sizes

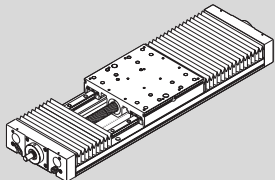

| Type | Guideway | Drive unit | Ball Rail Table |
|------|--|--|---|
| TKK |  Ball Rail Systems |  without drive unit |  |
| | |  Ball Screw Drive | |

Overview of Ball Rail Tables with permissible loads

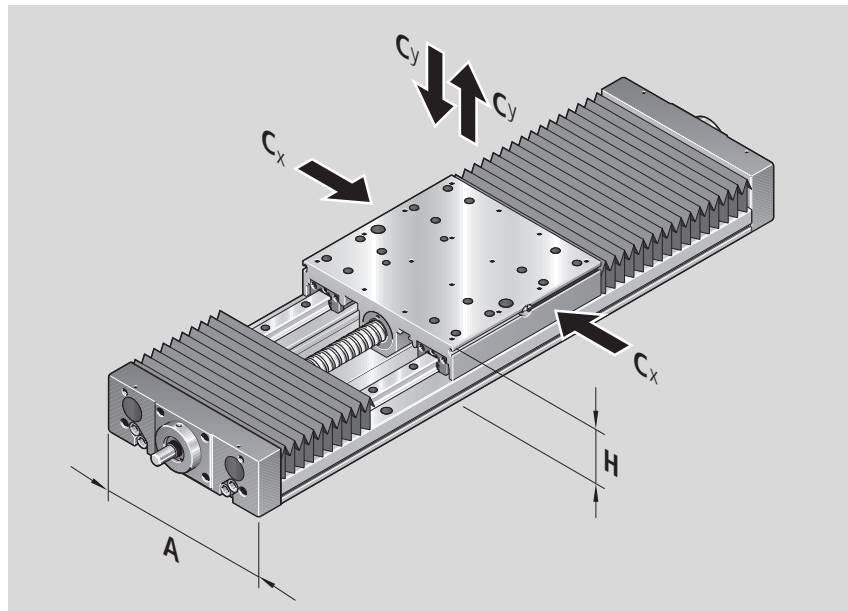

Suitable loads

(recommended values on the basis of past experience)

As far as the desired service life is concerned, loads of up to approximately 20% of the dynamic load and moment values (C , M_r , M_L) have proven acceptable.

With a side load above 8% C , it should be taken into account when considering the service life that only one rail is secured laterally.

Higher side loads are only taken up by the runner blocks on the secured rail.

In addition, the following values may not be exceeded:

- maximum permissible drive torque
- maximum permissible loads
- maximum permissible speeds

(For more details, see "Technical Data")

| Ball Rail Table | Dimensions A x H (mm) | - dyn. load capacity C_x (N) C_y (N) |
|-----------------|-----------------------|--|
| TKK 15 - 155 Al | 155 x 60 | 19 500 |
| TKK 20 - 225 Al | 225 x 75 | 64 300 |
| TKK 20 - 225 St | | |
| TKK 20 - 225 Al | 225 x 105 | 100 000 |
| TKK 30 - 325 Al | 325 x 90 | |
| TKK 30 - 325 St | | |
| TKK 30 - 325 Al | 325 x 120 | |
| TKK 35 - 455 Al | 455 x 120 | 132 500 |

STAR – Ball Rail® Tables TKK

Product Overview

Structure

- 1 Fixed bearing end-plate
- 2 and 5 Bellows, two-part
- 3 Precision ball screw assembly with zero backlash nut
- 4 Carriage with 4 long runner blocks
- 6 Floating bearing end-plate
- 7 Base plate

Accessories

- 8 Mechanical switch, external
- 9 Cable duct
- 10 Switching cam
- 11 Proximity switch, external
- 12 Socket/plug for external switches
- 13 Mechanical and proximity switches, internal
- 14 Socket/plug for internal switches
- 15 Profiled support

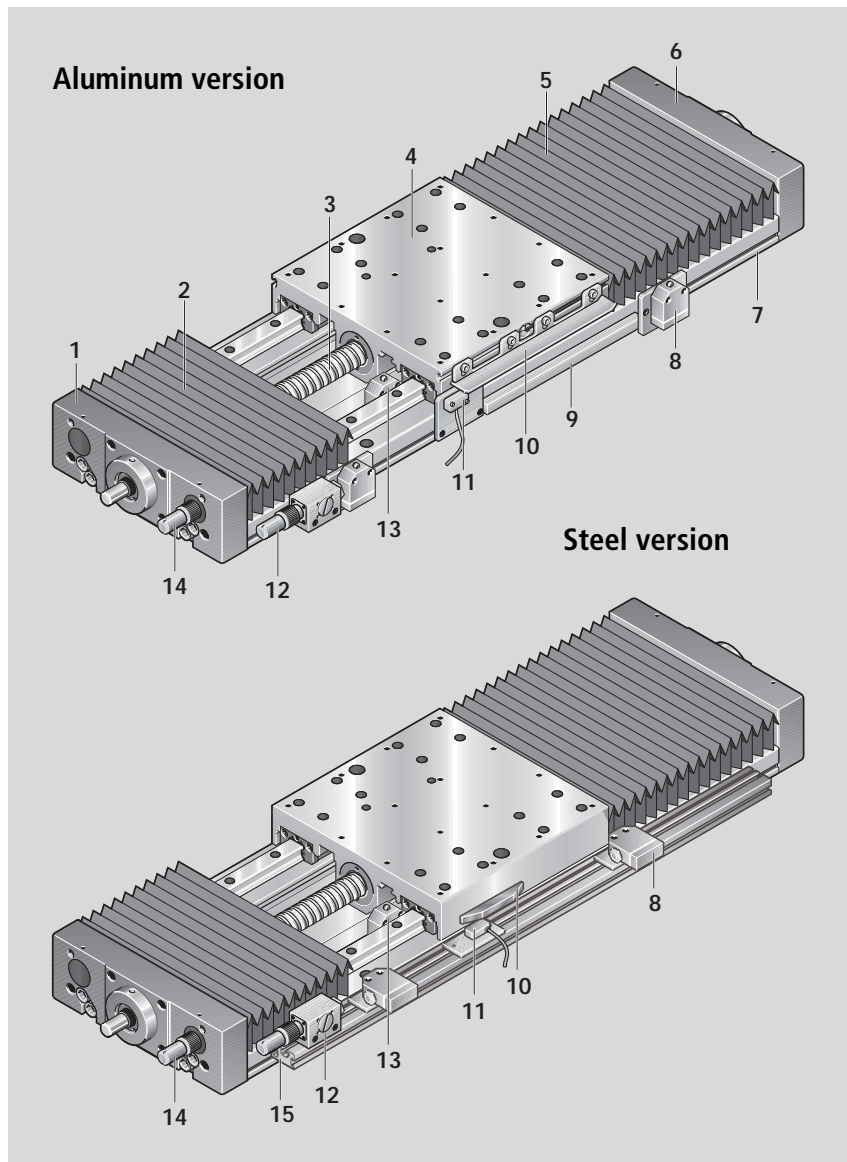

- 16 Motor
- 17 Motor mount and coupling
- 18 Timing belt with side drive

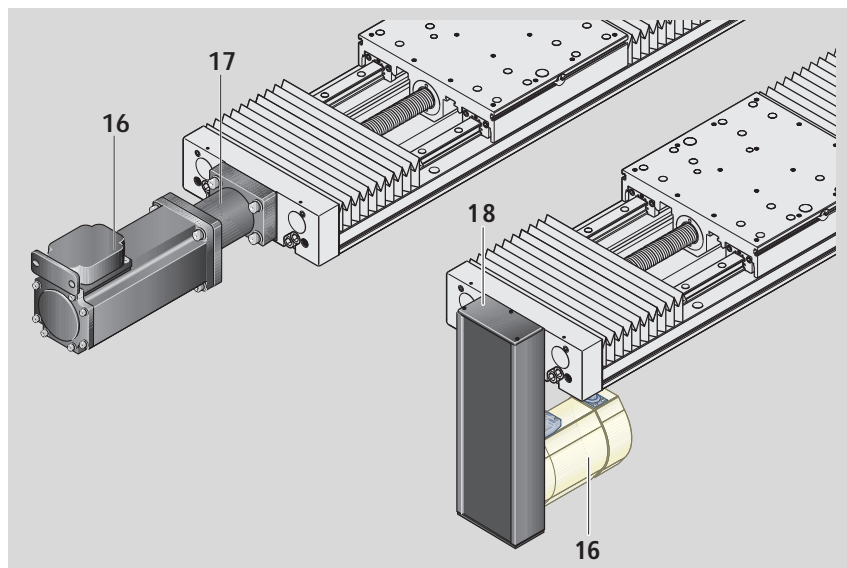

Motor attachment with mount and coupling

A motor can be attached using a mount and coupling to all Ball Rail Tables.

The motor mount serves both to attach the motor to the Ball Rail Table and as an enclosed housing for the coupling.

The coupling transmits the motor torque to the Ball Rail Table drive shaft without radial force or stress.

Our standard couplings compensate for the thermal expansion of the system.

If other makes of couplings are used, their thermal expansion must be taken into account.

- 1 Motor
- 2 Motor mount
- 3 Coupling
- 4 Ball Rail Table

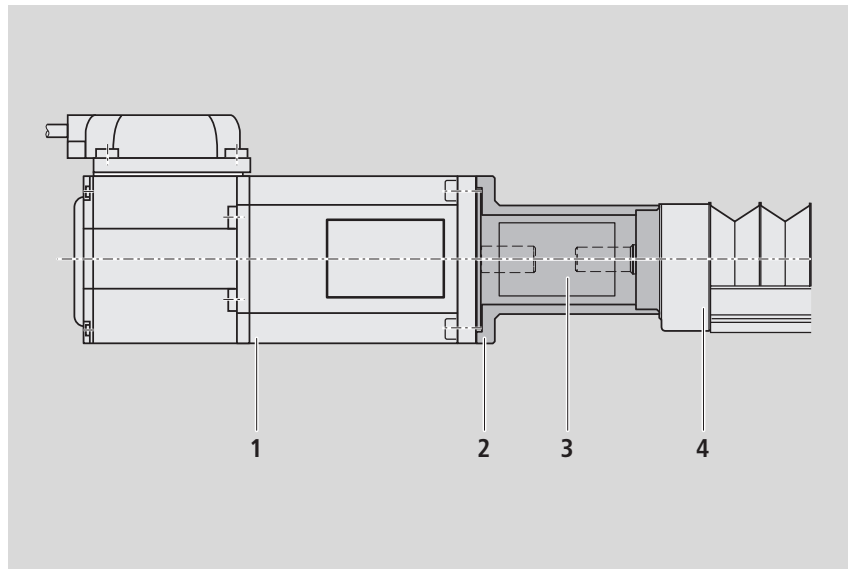

Motor attachment via side drive with timing belt

In all Ball Rail Tables the motor can be attached using a side drive with timing belt.

This results in a shorter overall length compared to a motor attachment using motor mount and coupling.

The compact, enclosed housing acts as a belt guard and secures the motor.

Different gear ratios are available:

$$i = 1$$

$$i = 1.5$$

$$i = 2$$

The side drive with timing belt can be mounted in four directions:

- bottom, top (RV05 and RV06)
- left, right (RV01 to RV04)

- 1 Ball Rail Table
- 2 Anodized aluminum frame
- 3 Toothed belt
- 4 AC servomotor
- 5 Pretensioning of the toothed belt: Apply pretensioning force F_v to the motor (F_v will be indicated on delivery)
- 6 Belt pulleys attached using clamping fixtures
- 7 Cover plate
- 8 Cover

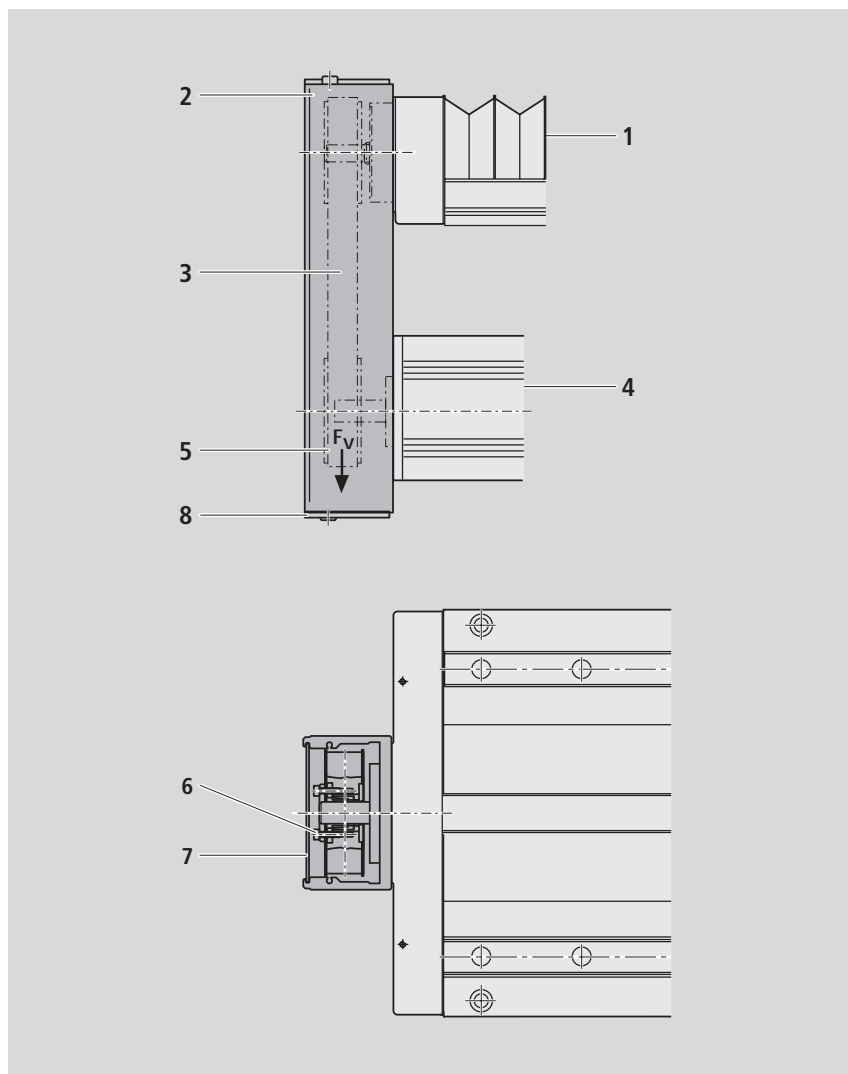

STAR – Ball Rail® Tables TKK

Mounting Accuracy

General notes on mounting

The Aluminum Ball Rail Tables can be mounted from above or below.

The Steel Ball Rail Tables can only be mounted by bolting from above. In both versions, a reference edge is built into the base plate to help align the unit.

The mounting hole plugs are included with the unit.

For connection dimensions, see the relevant dimension drawings.

Aluminum Ball Rail Tables

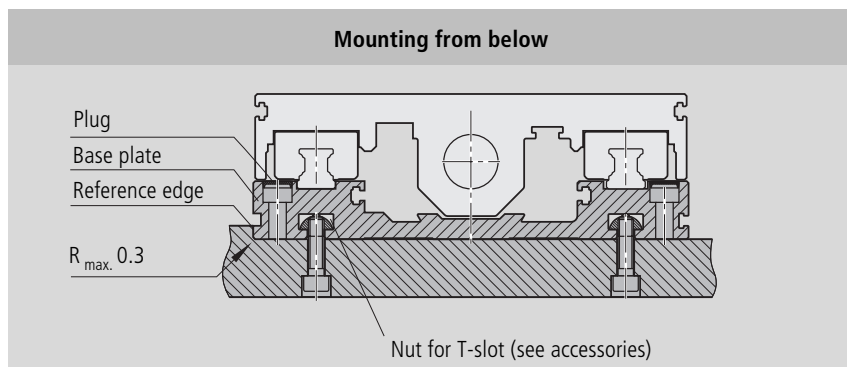
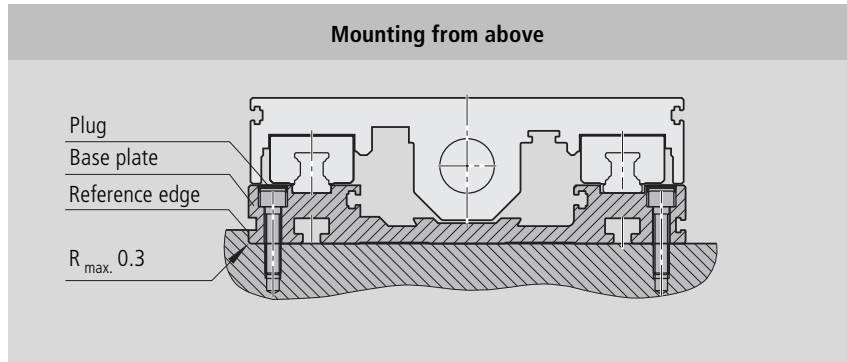

Steel Ball Rail Tables

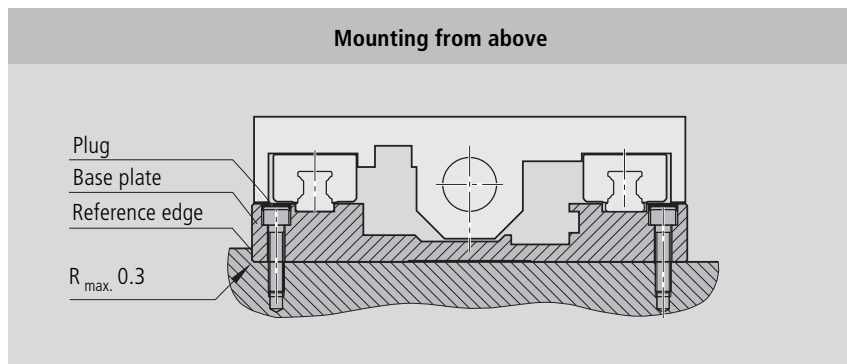

Accuracy

All accuracy data apply to the unit when screwed down and assume an ideal flat mounting surface. Irregularities in the mounting surface are not taken into account in the values given below.

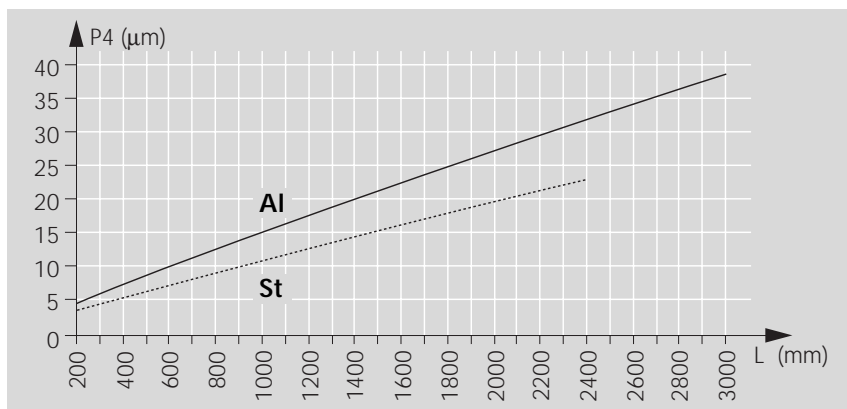
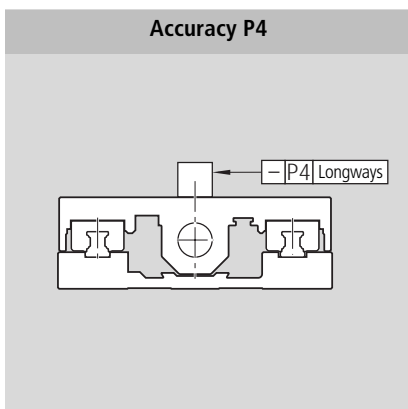
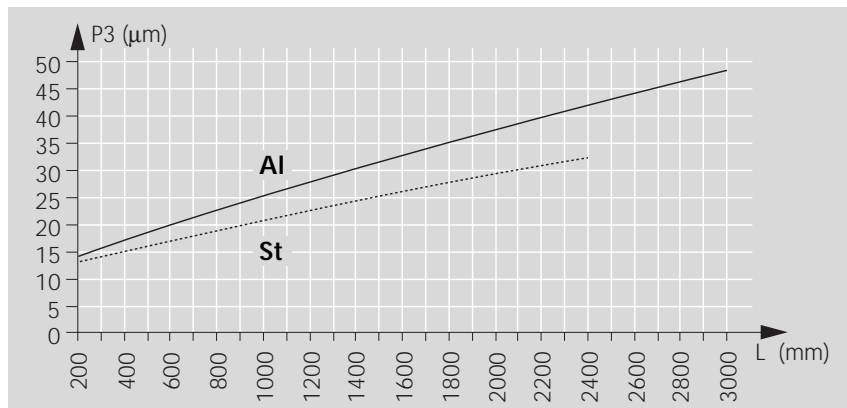
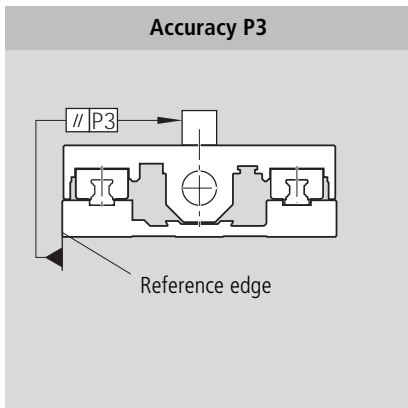
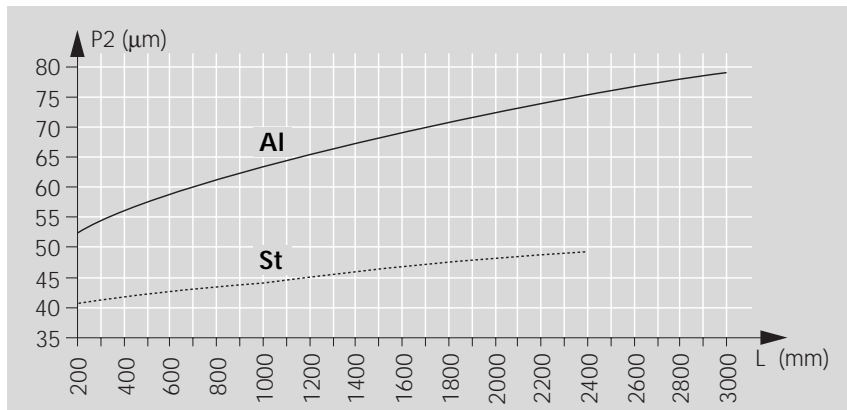
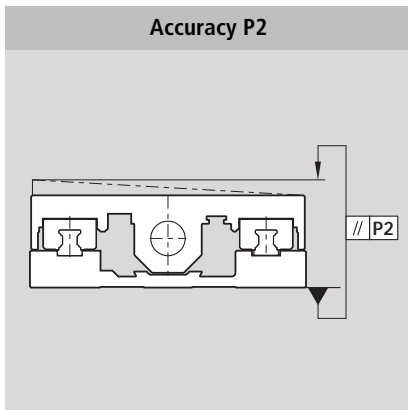
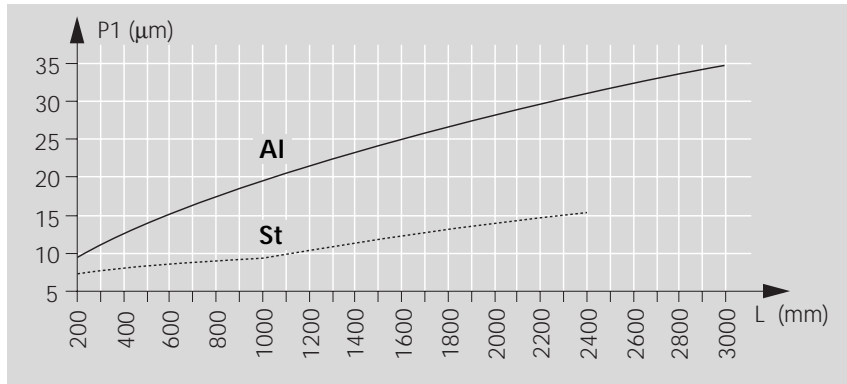
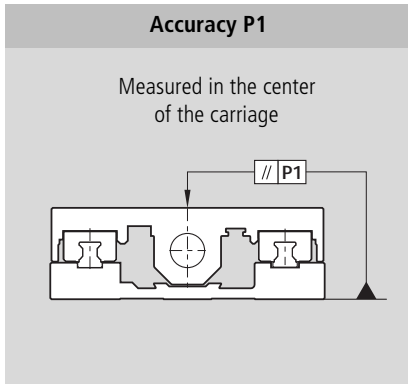

STAR – Ball Rail® Tables TKK

Technical Data

General system data

| Ball Rail Table | Ball screw $d_0 \times P$ | Dynamic load capacity | | | Dynamic moments | | | Maximum loads | |
|--------------------------------|------------------------------|-----------------------|----------------|-------------------|-----------------|-------------|-------------|---------------|-----------|
| | | Guide-way (N) | Ball screw (N) | Fixed bearing (N) | M_t (Nm) | M_L (Nm) | M_L (Nm) | F_V (N) | F_H (N) |
| TKK 15-155 AI | without | | – | – | | | | | |
| | 16 x 10 | 25300 | 9600 | 17000 | 1330 | 1160 | 2050 | 24000 | 6000 |
| | 16 x 16 | | 9300 | | | | | | |
| | 20 x 5 | | 14300 | | | | | | |
| | 20 x 20 | | 13300 | | | | | | |
| | | | | | $L_T = 150$ | $L_T = 220$ | | | |
| TKK 20-225 AI TKK 20-225 St | without | | – | – | | | | | |
| | 20 x 5 | 79200 | 14300 | 17000 | 6340 | 5150 | 9110 | 79200 | 19800 |
| | 20 x 20 | | 13300 | | | | | | |
| | 25 x 5 | | 15900 | | | | | | |
| | 25 x 10 | | 15700 | | | | | | |
| | 25 x 25 | AI only | 14700 | | | $L_T = 220$ | $L_T = 320$ | | |
| TKK 30-325AI TKK 30-325 St | without | | – | – | | | | | |
| | 32 x 5 | 129960 | 21600 | 26000 | 14940 | 11890 | 20330 | 123200 | 30800 |
| | 32 x 10 | | 31700 | | | | | | |
| | 32 x 20 | | 19700 | | | | | | |
| | 32 x 32 | | 19500 | | | | | | |
| | | | | | $L_T = 320$ | $L_T = 450$ | | | |
| TKK 35-455AI | without | | – | – | | | | | |
| | 40 x 5 | 180600 | 29100 | 29000 | 27090 | 24740 | | 163200 | 40800 |
| | 40 x 10 | | 50000 | | | | | | |
| | 40 x 20 | | 37900 | | | | | | |
| | 40 x 40 | | 37000 | | | | | | |
| | | | | | $L_T = 450$ | | | | |

Notes on dynamic load capacities and moments

The dynamic load capacities and moments of the guideway are based on 100,000 m travel.

However, a travel of just 50,000 m is often taken as a basis.

If this is the case, for comparison purposes:

Multiply values **C**, **M_t** and **M_L** from the STAR table by 1.26.

Load ratings for the precision ball screw assembly comply with DIN 69051.

| E · I values | | | | Carriage mass m _b | | Weight | | | | |
|--------------------------------------|--------------------------------------|--------------------------------------|--------------------------------------|------------------------------|----------------------|--------|---|--|--------------------------------------|--|
| | | | | | | | L = Length in mm m _b = Moved mass | | | |
| E · I _x | E · I _y | E · I _x | E · I _y | (kg) | (kg) | (kg) | | | (kg) | |
| (·10 ⁸ Ncm ²) | (·10 ⁸ Ncm ²) | (·10 ⁸ Ncm ²) | (·10 ⁸ Ncm ²) | | | | | | | |
| | | | | L _T = 150 | L _T = 220 | | | | | |
| 3.07 | 62.17 | - | - | 2.3 | 3 | (1) | 0.010 · L + m _b - 0.3 | | | |
| | | | | | | (2) | 0.0124 · L + m _b + 2 | | | |
| | | | | L _T = 220 | L _T = 320 | | | | | |
| TKK 20-225 AI | | | | | | | | | | |
| 5.13 | 196.59 | 25.27 | 355.95 | 7 | 9 | (1) | 0.015 · L + m _b - 0.4 | | (1) 0.026 · L + m _b - 0.4 | |
| | | | | | | (2) | 0.018 · L + m _b + 3 | | (2) 0.029 · L + m _b + 3 | |
| TKK 20-225 St | | | | | | | | | | |
| 9.88 | 577.03 | - | - | 13 | 18 | (1) | 0.040 · L + m _b - 0.4 | | | |
| | | | | | | (2) | 0.043 · L + m _b + 3 | | | |
| | | | | L _T = 320 | L _T = 450 | | | | | |
| TKK 30-325 AI | | | | | | | | | | |
| 9.92 | 664.00 | 45.69 | 1156.91 | 17 | 23 | (1) | 0.029 · L + m _b - 1 | | (1) 0.048 · L + m _b - 1 | |
| | | | | | | (2) | 0.035 · L + m _b + 5 | | (2) 0.054 · L + m _b + 5 | |
| TKK 30-325 St | | | | | | | | | | |
| 17.27 | 1826.96 | - | - | 33.5 | 45.4 | (1) | 0.070 · L + m _b - 1 | | | |
| | | | | | | (2) | 0.076 · L + m _b + 5 | | | |
| | | | | L _T = 450 | | | | | | |
| 34.71 | 2554.23 | - | - | 41 | | (1) | 0.056 · L + m _b - 2.5 | | | |
| | | | | | | (2) | 0.066 · L + m _b + 12 | | | |

E = Modulus of elasticity
I = Planar moment of inertia
L_T = Carriage length

(1) = without ball screw drive and end-plates
(2) = with ball screw drive and end-plates

Weight data does not include motor and switch attachments.

STAR – Ball Rail® Tables TKK

Technical Data

Permissible speed

| Ball Rail Table | Permissible speed v_{per} (m/min) |
|----------------------------------|--|
| without drive without bellows | 180 m/min ^{*)} |
| without drive with bellows | 100 m/min |
| with drive with bellows | see graphs |
| with drive without bellows | $f \cdot v_{per}$ v_{per} : see graphs f : see table |

*) Speeds up to 300 m/min are possible, but service life is limited by increased wear of the plastic components in the ball rail systems. Tests have shown distances of 50 to $100 \cdot 10^5$ m without failure.

Example: for TKK 30-325 AI with ball screw drive 32 x 32 but without bellows, with $L = 1980$ mm

Permissible speed:

$$v_{per} = f \cdot v = 0.89 \cdot 57 \text{ m/min}$$

$$v_{per} = 50.73 \text{ m/min}$$

(where $v = 57$ m/min from graph and $f = 0.89$ from table)

Reduction factor f for version with ball screw drive without bellows

| Table | Ball screw diam. | L (mm) | f |
|------------|------------------|--------|------|
| TKK 15-155 | 16 | ≤ 820 | 1.0 |
| | | > 820 | 0.83 |
| TKK 20-225 | 20 | ≤ 940 | 1.0 |
| | | > 940 | 0.83 |
| TKK 30-325 | 32 | ≤ 1580 | 1.0 |
| | | > 1580 | 0.89 |
| TKK 35-455 | 40 | ≤ 1900 | 1.0 |
| | | > 1900 | 0.91 |



When selecting the motor, take account of the permissible speed of the Ball Rail Table or the selected ball screw drive.

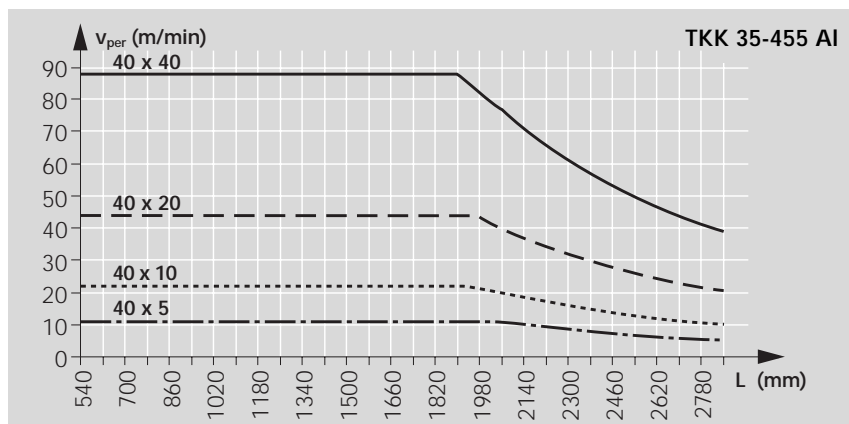
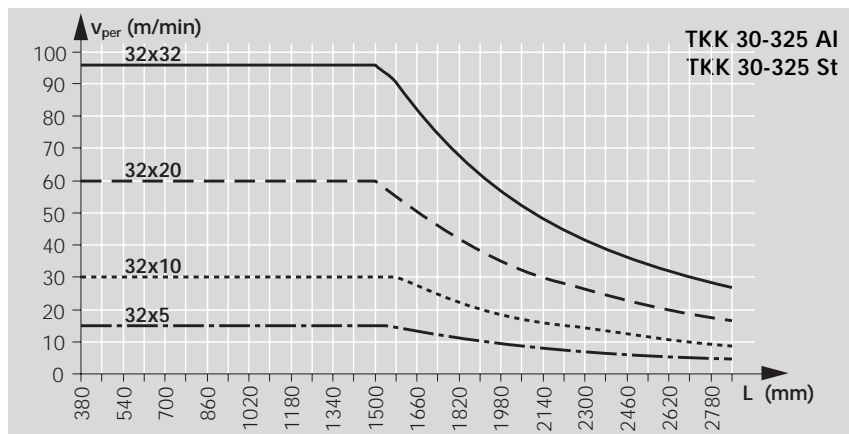
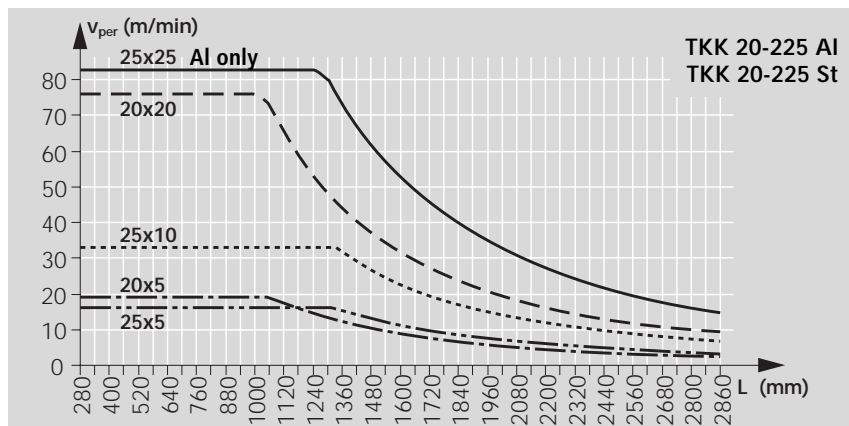
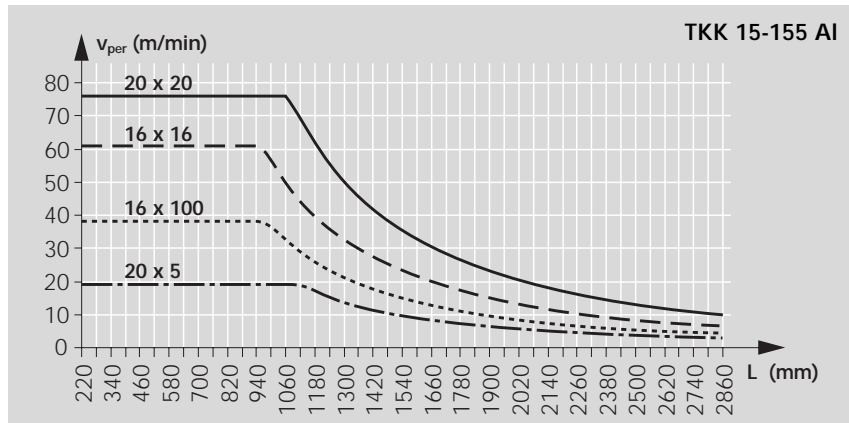

**Permissible drive torque,
Fixed bearing end**

For motor attachment via motor mount and coupling.

⚠ For the permissible torque with a motor attached using side drive with timing belt, see "Timing belt side drive, Floating bearing end".

The values of M_{per} shown apply under the following conditions:

- Horizontal operation
- Ball screw drive journal without keyway
- No radial load on the ball screw drive journal
- Ball rail table with polyurethane bellows

⚠ Take account of the rated torque of the coupling used!

Ball screw journal with keyway

Due to notch effect and the reduction of the effective diameter, observe the following maximum values for the drive torque!

| Ball Rail Table | M_{per} (Nm) |
|-----------------|---|
| 15-155 | 4.5 |
| 20-225 | 4.5 (Ball screw dia. 20) 11 (Ball screw dia. 25) |
| 30-325 | 18 |
| 35-455 | 76 |

⚠ When comparing the graph and table, the lower of the two values applies in each case!

Example:
TKK 15-155, ball screw 20x5,
length 1060 mm.

Drive torque M_{per} from graph:
~ 2.7 Nm

Maximum permissible drive torque as per table: 4.5 Nm

Drive torque for sizing: 2.7 Nm

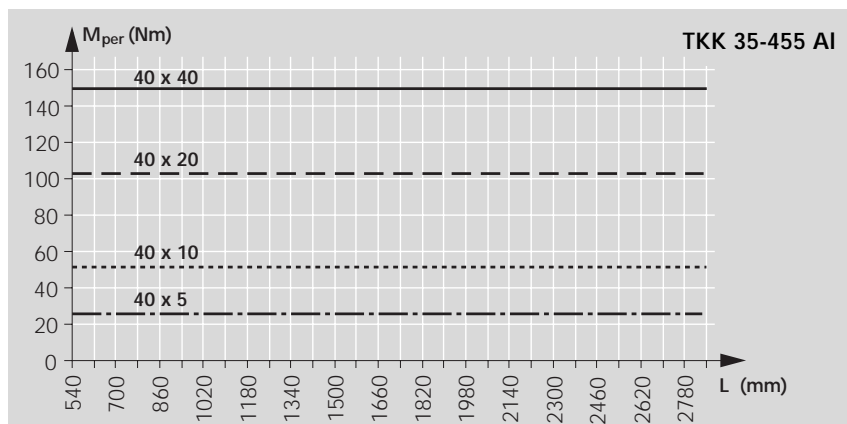
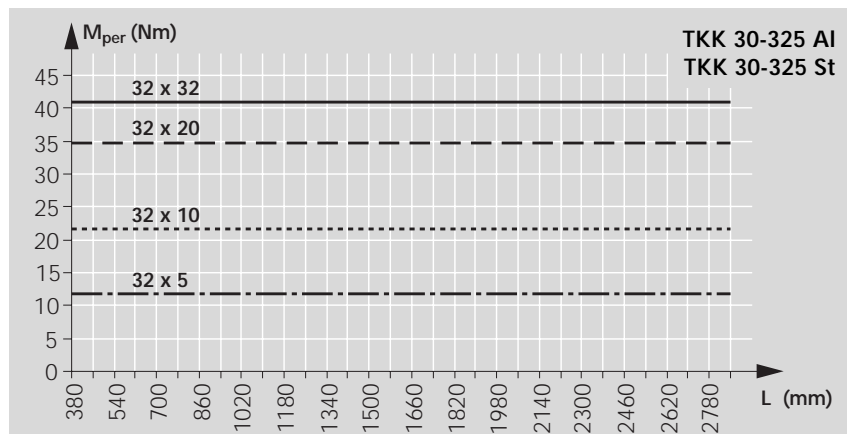
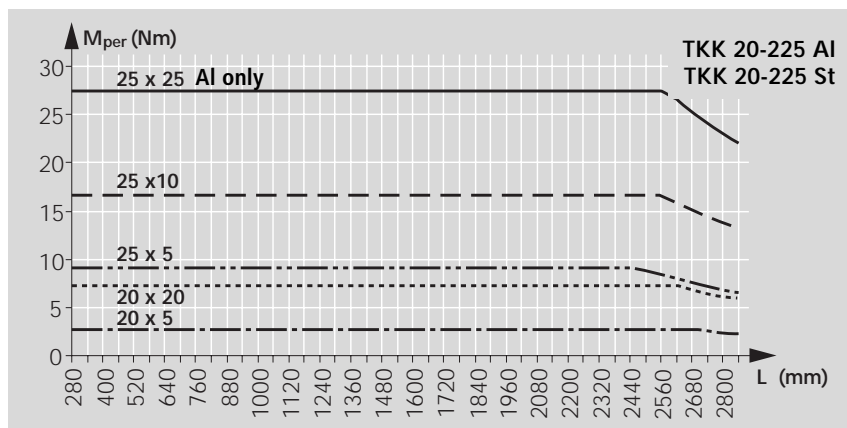

STAR – Ball Rail® Tables TKK

Technical Data

Drive data of the side drive with timing belt, Floating bearing end for motor attachment via side drive with timing belt

| Motor type | | MKD 41B, MMD 082A | | | | | MHD 71A | | | | |
|--------------------------------|----------------|---|----------|----------|-----------------------------------|--------------------------------|---|----------|----------|-----------------------------------|--------------------------------|
| Overall dimensions (mm) | | 51 x 88 | | | | | 66 x 116 | | | | |
| Friction moment M_{RRV} (Nm) | | 0.4 | | | | | 0.45 | | | | |
| | | Permissible torque up to length L = ... at ⁽¹⁾ | | | Reduced mass moment of inertia at | | Permissible torque up to length L = ... at ⁽¹⁾ | | | Reduced mass moment of inertia at | |
| Reduction i = ... | | | i = 1 | i = 1.5 | i = 1 | i = 1.5 | | i = 1 | i = 2 | i = 1 | i = 2 |
| Belt type | | | 16 AT5 | 16 AT5 | 16 AT5 | 16 AT5 | | 25 AT5 | 25 AT5 | 25 AT5 | 25 AT5 |
| Ball Rail Table | Ball screw | L | M_{RV} | M_{RV} | J_{RV} | J_{RV} | L | M_{RV} | M_{RV} | J_{RV} | J_{RV} |
| | $d_0 \times P$ | (mm) | (Nm) | (Nm) | (10^{-6} kgm ²) | (10^{-6} kgm ²) | (mm) | (Nm) | (Nm) | (10^{-6} kgm ²) | (10^{-6} kgm ²) |
| TKK 15-155 | 16 x 10 | 1180 | 9.6 | 6.4 | 260 | 91 | 1060 | 11.6 | 5.8 | 1420 | 230 |
| | 16 x 16 | 1420 | 9.6 | 6.4 | | | 1300 | 11.6 | 5.8 | | |
| | 20 x 5 | 1420 | 9.6 | 6.4 | | | 1420 | 10.0 | 5.0 | | |
| | 20 x 20 | 2260 | 9.6 | 6.4 | | | 1540 | 19.6 | 9.8 | | |
| TKK 20-225 | 20 x 5 | 1480 | 9.6 | 6.4 | 270 | 94 | 1480 | 10.0 | 5.0 | 1420 | 230 |
| | 20 x 20 | 2200 | 9.6 | 6.4 | | | 1600 | 19.6 | 9.8 | | |
| | 25 x 5 | 2320 | 9.6 | 6.4 | | | 1960 | 14.0 | 7.0 | | |
| | 25 x 10 | 2860 | 9.6 | 6.4 | | | 2320 | 19.6 | 9.8 | | |
| | 25 x 25 | 2860 | 9.6 | 6.4 | | | 2860 | 19.6 | 9.8 | | |
| TKK 30-325 | 32 x 5 | | | | | | 2860 | 19.0 | 9.5 | 1440 | 240 |
| | 32 x 10 | | | | | | 2860 | 19.0 | 9.5 | | |
| | 32 x 20 | | | | | | 2860 | 19.0 | 9.5 | | |
| | 32 x 32 | | | | | | 2860 | 19.0 | 9.5 | | |
| TKK 35-455 | 40 x 5 | | | | | | | | | | |
| | 40 x 10 | | | | | | | | | | |
| | 40 x 20 | | | | | | | | | | |
| | 40 x 40 | | | | | | | | | | |

M_{RV} ... Permissible system torque with side drive with timing belt on the motor journal (motor torque not taken into account)

M_{RRV} ... Friction moment, side drive with timing belt on the motor journal

J_{RV} ... Reduced mass moment of inertia, side drive with timing belt







i ... Reduction, side drive with timing belt

(1) ... Please ask if you wish to know the permissible torque for longer lengths

Technical data AC servomotors

| Motor | MKD 41B-144 | MMD 082A | MHD 71A-061 | MKD 71B-061 |
|--|-------------|----------|-------------|-------------|
| Maximum effective rotary speed n_M (1/min) | ⚡ | ⚡ | ⚡ | ⚡ |
| Rated torque M_{MN} (Nm) | 2.7 | 2.4 | 3.5 | 8 |
| Maximum torque M_{Mmax} (Nm) | ⚡ | ⚡ | ⚡ | ⚡ |
| Mass moment of inertia $J_M + J_{Br}$ (10^{-6} kgm ²) | 170 + 16 | 133 + 8 | 440 + 72 | 870 + 38 |
| Braking torque M_{Br} (Nm) | 2.2 | 2.4 | 5 | 5 |
| Load with brake m_{Br} (kg) | 4.65 | 3.7 | 6.6 | 9.42 |

| | | MKD 71B, MHD 71B | | | | | | MKD 90B, MHD 90B | | | | | | | |
|--|--|---|-----------------|-----------------|-----------------------------------|--------------------------------------|-----------------|---|---------|-----------------|-----------------------------------|--------------------------------------|-----------------|--|--|
| | | 66 x 116 | | | | | | 90 x 160 | | | | | | | |
| | | 0.5 | | | | | | 0.6 | | | | | | | |
| | | Permissible torque up to length L = ... at ⁽¹⁾ | | | Reduced mass moment of inertia at | | | Permissible torque up to length L = ... at ⁽¹⁾ | | | Reduced mass moment of inertia at | | | | |
| | | i = 1 | | i = 2 | i = 1 | | i = 2 | i = 1 | | i = 2 | i = 1 | | i = 2 | | |
| | | 25 AT5 | 32 AT5 | 32 AT5 | 25 AT5 | 32 AT5 | 32 AT5 | 50 AT10 | 50 AT10 | 50 AT10 | 50 AT10 | 50 AT10 | 50 AT10 | | |
| | | L | M _{Rv} | M _{Rv} | M _{Rv} | J _{Rv} | J _{Rv} | J _{Rv} | L | M _{Rv} | M _{Rv} | J _{Rv} | J _{Rv} | | |
| | | (mm) | (Nm) | (Nm) | (Nm) | (10 ⁻⁶ kgm ²) | | | (mm) | (Nm) | (Nm) | (10 ⁻⁶ kgm ²) | | | |
| | | | | | | | | | | | | | | | |
| | | | | | | | | | | | | | | | |
| | | | | | | | | | | | | | | | |
| | | | | | | | | | | | | | | | |
| | | 2860 | 19.0 | | 9.5 | 1440 | | 280 | | | | | | | |
| | | 2860 | 19.0 | | 13.0 | | | | | | | | | | |
| | | 2860 | 19.0 | | 13.0 | | | | | | | | | | |
| | | 2860 | 19.0 | | 13.0 | | | | | | | | | | |
| | | 2860 | | 26.0 | 13.0 | 1680 | 290 | 2860 | 26.0 | 13.0 | 7860 | 1280 | | | |
| | | 2860 | | 26.0 | 13.0 | | | 2860 | 52.0 | 26.0 | | | | | |
| | | 2860 | | 26.0 | 13.0 | | | 2860 | 67.0 | 33.5 | | | | | |
| | | 2860 | | 26.0 | 13.0 | | | 2860 | 67.0 | 33.5 | | | | | |

| | MHD 71B-061 | MKD 90B-047 | MHD 90B-047 |
|--|---|---|---|
| |  |  |  |
| | 8 | 12 | 12 |
| |  |  |  |
| | 870 + 72 | 4300 + 360 | 4300 + 360 |
| | 5 | 11 | 11 |
| | 9.4 | 15.1 | 14.6 |

 refer to catalog "Controllers, Motors, Electrical Accessories" RE 82 701

For the motor data of stepping motors, see the section on "Motors"

STAR – Ball Rail® Tables TKK

Calculation Bases

Formulas

Nominal service life

| | |
|---|--|
| Nominal service life in meters: $L_{10} = \left(\frac{C}{F_m}\right)^3 \cdot 10^5$ | L_{10} = Nominal service life in meters (m) |
| Nominal service life in hours: $L_{10h} = \frac{L_{10}}{60 \cdot v}$ | L_{10h} = Nominal service life in hours (h) |
| | C = Dynamic load capacity (N) |
| | F_m = Mean equivalent dynamic load (N) |
| | v = Speed (m/min) (from "Permissible speed" graph) |

Friction moment

for motor attachment using motor mount and coupling

$$M_R = M_{RS}$$

| | |
|-----------|--|
| M_R | = Friction moment at the drive journal (Nm) |
| M_{RS} | = Friction moment, system (Nm) |
| M_{RRV} | = Friction moment, side drive with timing belt at motor journal (Nm) |
| i | = Reduction |

for motor attachment using side drive with timing belt

$$M_R = \frac{M_{RS}}{i} + M_{RRV}$$

Constants k_1, k_2, k_3

Moment of friction of system at motor journal M_R

d_0 = Nominal diameter ball screw drive (mm)

P = Lead ball screw drive (mm)

| Ball Rail Table | Ball screw $d_0 \times P$ (mm) | Constants | | | Moment of friction M_{RS} (Nm) for | | |
|-----------------|--------------------------------|-------------------------|------------------------|-------|--------------------------------------|------------------------|------------------------|
| | | k_1 short carriage | k_1 long carriage | k_2 | k_3 | 2% preload of guideway | 8% preload of guideway |
| TKK 15-155 | 16 x 10 | 10.5 | 12.3 | 0.039 | 2.53 | 0.56 | 0.58 |
| | 16 x 16 | 19.6 | 24.2 | 0.039 | 6.48 | 0.58 | 0.61 |
| | 20 x 5 | 13.6 | 14.1 | 0.100 | 0.63 | 0.64 | 0.65 |
| | 20 x 20 | 35.5 | 42.5 | 0.100 | 10.13 | 0.72 | 0.75 |
| TKK 20-225 Al | 20 x 5 | 16.6 | 17.9 | 0.100 | 0.63 | 0.66 | 0.68 |
| | 20 x 20 | 83.1 | 103.3 | 0.100 | 10.13 | 0.82 | 0.90 |
| | 25 x 5 | 35.4 | 36.6 | 0.256 | 0.63 | 0.82 | 0.84 |
| | 25 x 10 | 48.7 | 53.7 | 0.256 | 2.53 | 0.88 | 0.92 |
| TKK 20-225 St | 25 x 25 | 139.3 | 170.9 | 0.235 | 15.83 | 1.08 | 1.17 |
| | 20 x 5 | 20.4 | 23.5 | 0.100 | 0.63 | 0.66 | 0.68 |
| | 20 x 20 | 143.9 | 194.5 | 0.100 | 10.13 | 0.82 | 0.90 |
| TKK 30-325 Al | 25 x 5 | 39.2 | 42.3 | 0.256 | 0.63 | 0.82 | 0.84 |
| | 25 x 10 | 63.9 | 76.5 | 0.256 | 2.53 | 0.88 | 0.92 |
| | 32 x 5 | 110.0 | 113.8 | 0.712 | 0.63 | 1.10 | 1.12 |
| TKK 30-325 St | 32 x 10 | 142.3 | 157.5 | 0.712 | 2.53 | 1.29 | 1.32 |
| | 32 x 20 | 265.3 | 326.1 | 0.667 | 10.13 | 1.21 | 1.27 |
| | 32 x 32 | 534.0 | 689.6 | 0.667 | 25.94 | 1.36 | 1.46 |
| TKK 35-455 | 32 x 5 | 120.5 | 128.0 | 0.712 | 0.63 | 1.10 | 1.12 |
| | 32 x 10 | 184.1 | 214.3 | 0.712 | 2.53 | 1.29 | 1.32 |
| | 32 x 20 | 432.5 | 553.0 | 0.667 | 10.13 | 1.21 | 1.27 |
| | 32 x 32 | 962.0 | 1270.6 | 0.667 | 25.94 | 1.36 | 1.46 |
| TKK 35-455 | 40 x 5 | 319.2 | | 1.783 | 0.63 | 1.66 | 1.68 |
| | 40 x 10 | 368.2 | | 1.607 | 2.53 | 2.32 | 2.35 |
| | 40 x 20 | 679.7 | | 1.607 | 10.13 | 2.24 | 2.29 |
| | 40 x 40 | 1926.0 | | 1.607 | 40.53 | 2.59 | 2.69 |

Mass moment of inertia

| | |
|--|--|
| for handling: $6 \cdot J_M \geq J_{fr}$ | J_{fr} = External mass moment of inertia (kgm ²) |
| for processing: $1.5 \cdot J_M \geq J_{fr}$ | J_M = Mass moment of inertia of motor (kgm ²) |

for motor attachment using motor mount and coupling

| | |
|--|---|
| $J_{fr} = J_S + J_K + J_{Br}$ | J_{tot} = Total mass moment of inertia (kgm ²) |
| $J_S = (k_1 + k_2 \cdot L + k_3 \cdot m_{fr}) \cdot 10^{-6}$ | J_{fr} = External mass moment of inertia (kgm ²) |
| $J_{tot} = J_{fr} + J_M = J_S + J_K + J_{Br} + J_M$ | J_S = Mass moment of inertia of system with additional load (kgm ²) |
| | J_K = Mass moment of inertia of coupling (kgm ²) |
| | J_{Br} = Mass moment of inertia, motor brake (kgm ²) |
| | J_M = Mass moment of inertia of motor (kgm ²) |
| | J_{Rv} = Reduced mass moment of inertia, side drive with timing belt at motor journal (kgm ²) |
| | m_{fr} = External load (kg) |
| | L = Length of Ball Rail Table (mm) |
| | i = Reduction |
| | k_1, k_2, k_3 = Constants, see "Constants" table |

for motor attachment using side drive with timing belt

| | |
|--|---|
| $J_{fr} = \frac{J_S}{i^2} + J_{Rv} + J_{Br}$ | J_M = Mass moment of inertia of motor (kgm ²) |
| $J_S = (k_1 + k_2 \cdot L + k_3 \cdot m_{fr}) \cdot 10^{-6}$ | J_{Rv} = Reduced mass moment of inertia, side drive with timing belt at motor journal (kgm ²) |
| $J_{tot} = J_{fr} + J_M = \frac{J_S}{i^2} + J_{Rv} + J_M + J_{Br}$ | m_{fr} = External load (kg) |
| | L = Length of Ball Rail Table (mm) |
| | i = Reduction |
| | k_1, k_2, k_3 = Constants, see "Constants" table |

Rotary speed

If a geared motor is fitted, the moment of inertia of the gears and the gear transmission ratios must be taken into account.

| | |
|--|--|
| $n_1 = \frac{i \cdot v \cdot 1000}{P}$ | v = Speed (m/min) |
| $n_1 < n_{Mmax}$ | n_1 = Speed at motor journal (1/min) |
| $v \leq v_{per}$ | n_{Mmax} = Maximum effective rotary speed of motor (1/min) |
| | P = Ball screw lead (mm) |
| | i = Reduction |
| | v_{per} = Permissible speed (m/min) (see "Technical Data") |

Coupling Data

Couplings with data as given in the table are used for Ball Rail Tables TTK... with standard servomotors.

| Ball Rail Table | Rated torque of coupling M_K (Nm) | Mass moment of inertia J_K (kgm ²) | Coupling mass (kg) |
|-----------------|-------------------------------------|--|--------------------|
| TKK 15-155 | 19 | $57 \cdot 10^{-6}$ | 0.26 |
| TKK 20-225 | 19 | $57 \cdot 10^{-6}$ | 0.26 |
| | 50 | $200 \cdot 10^{-6}$ | 0.7 |
| TKK 30-325 | 50 | $200 \cdot 10^{-6}$ | 0.7 |
| TKK 35-455 | 98 | $390 \cdot 10^{-6}$ | 0.9 |

STAR – Ball Rail® Tables TKK

Calculation Bases

When sizing the drive, always take the motor/controller combination into consideration as the motor type and per-

formance data (e.g. maximum effective speed and maximum torque) depend on the controller or control system used.

(See also "Product Overview, Motor pre-selection in accordance with controllers and control systems").

Starting data

A mass of 150 kg is to be moved 500 mm at a maximum velocity of 40 m/min.

The following unit is selected on the basis of its technical data and mounting dimensions:

Ball rail table TKK 30-325 AI

- $L_T = 320$ mm
- 2% preload
- with bellows cover
- with size 71 AC servomotor, connected via motor mount and coupling

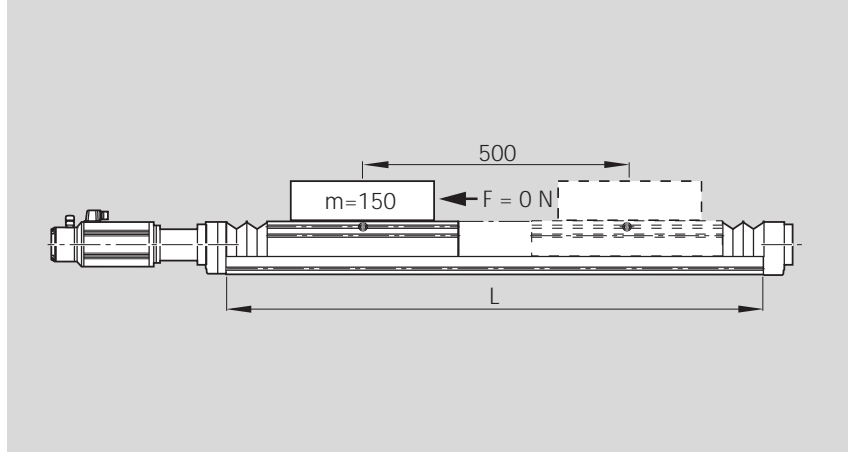

Length estimate

$$\begin{aligned} \text{Excess travel} &= 2 \cdot P = 2 \cdot 32 \text{ mm} = 64 \text{ mm} \\ \text{Max. travel} &= \text{Stroke}_{\text{effective}} + 2 \cdot \text{excess travel} \\ &= 500 \text{ mm} + 2 \cdot 64 \text{ mm} \\ &= 628 \text{ mm} \\ \text{Length L:} & \quad \text{for max. travel} = 628 \text{ mm} \\ & \quad \text{from Data Sheet TKK 30-325 AI} \\ & \quad L = 1100 \text{ mm} \end{aligned}$$

Selection of the ball screw drive

See "Technical Data" section for graphs.

General recommendation:

Wherever possible, always select the smallest lead.

According to the graph for "Permissible speed", the permissible ball screw drives for $v = 40$ m/min and $L = 1100$ mm are:

ball screw 32 x 20 and ball screw 32 x 32
Selected ball screw drive (smaller lead)

ball screw 32 x 20
with a maximum permissible drive torque of 35 Nm as per "Permissible drive torque" graph for $L = 1100$ mm

Calculation

Length L

$$\begin{aligned} \text{Excess travel} &= 2 \cdot P = 2 \cdot 20 \text{ mm} = 40 \text{ mm} \\ \text{Max. travel} &= \text{Stroke}_{\text{effective}} + 2 \cdot \text{excess travel} \\ &= 500 \text{ mm} + 2 \cdot 40 \text{ mm} \\ &= 580 \text{ mm} \\ L &= 1020 \text{ mm for max. travel of 580 mm} \\ & \quad (582 \text{ mm}) \text{ from Data Sheet TKK 30-325 AI} \end{aligned}$$

Friction moment M_R

$$\begin{aligned} M_R &= M_{RS} \text{ (see "Technical Data")} \\ M_R &= 1.21 \text{ Nm} \end{aligned}$$

Mass moment of inertia

$$\begin{aligned} J_S &= (k_1 + k_2 \cdot L + k_3 \cdot m_{fr}) \cdot 10^{-6} \text{ kgm}^2 \quad (k_1, k_2, k_3 \text{ see "Constants"}) \\ &= (265.3 + 0.667 \cdot 1020 \text{ mm} + 10.13 \cdot 150 \text{ kg}) \cdot 10^{-6} \text{ kgm}^2 \\ &= 2465 \cdot 10^{-6} \text{ kgm}^2 \end{aligned}$$

$$J_K = 200 \cdot 10^{-6} \text{ kgm}^2 \quad (\text{see "Technical Data"})$$

$$J_{Br} = 38 \cdot 10^{-6} \text{ kgm}^2 \quad (\text{see "Motor Data"})$$

$$J_{fr} = J_S + J_K + J_{Br} = (2465 + 200 + 38) \cdot 10^{-6} \text{ kgm}^2 = 2703 \cdot 10^{-6} \text{ kgm}^2$$

for handling:

$$J_{aM} > \frac{J_{fr}}{6} = \frac{2703}{6}$$

$$J_M > 450 \cdot 10^{-6} \text{ kgm}^2$$

Rotary speed n

at $v = 40 \text{ m/min}$

$$n_1 = \frac{i \cdot v \cdot 1000}{P} = \frac{1 \cdot 40 \text{ m/min} \cdot 1000}{20 \text{ mm}} = 2000 \text{ min}^{-1} < n_{Mmax}$$

$$v = 40 \text{ m/min}$$

Result

Ball rail table TTK 30-325 Al

Length $L = 1020 \text{ mm}$

Ball screw drive:

Diameter $32 \text{ mm};$

Lead $20 \text{ mm};$

Carriage length: $L_T = 320 \text{ mm};$

Preload: 2%

Motor attached using motor mount and coupling

Motor with: – maximum effective speed $n_{Mmax} > 2000 \text{ min}^{-1}$

– mass moment of inertia $J_M > 450 \cdot 10^{-6} \text{ kgm}^2$

– maximum drive torque $M_{per} < 35 \text{ Nm}$

Take account of coupling torque M_K and friction moment M_R

($M_K = 50 \text{ Nm}; M_R = 1.21 \text{ Nm}$)

These conditions are met by all AC servomotors permitted in selection table TTK 30-325 Al.

The exact motor selection will depend on:

– the criteria from the "Motor Selection" overview

– recalculating the drive system with the performance data from catalog "Controllers, Motors, Electrical Accessories" RE 82 701.

STAR – Aluminum Ball Rail® Tables

TKK 15-155 Al Options Table

| Part number 1460-205-00, mm See dimensions table for length | | Type | Guide-way = .. | Drive unit = .. | | | | Carriage = .. | | | | | | | |
|--|--|-----------|----------------|----------------------------|----------------------------|------------------|--------|--------------------------------|---------------------------------------|----|----|----|----|----|----|
| | | | | | | | | | | | | | | | |
| | | | Base plate | Ball screw journal | | Ball screw drive | | Carriage length L _T | | | | | | | |
| | | | flat high | keyway | 16 x 10 | 16 x 16 | 20 x 5 | 20 x 20 | 150 mm Preload 2% 220 mm Preload 8% | | | | | | |
| without drive unit (without end-plates) | | | | | | | | | | | | | | | |
| OA01 | | | 01 | | | 00 | | | 01 | 02 | 03 | 04 | | | |
| without motor mount and motor | | | | | | | | | | | | | | | |
| OF01 | | OF04 | 01 | dia 10 (fixed bearing end) | 01 | 07 | 13 | 19 | 01 | 02 | 03 | 04 | | | |
| | | | | dia 10 keyway (fixed brg.) | 04 | 10 | 16 | 22 | | | | | | | |
| with motor mount and coupling, with or without motor | | | | | | | | | | | | | | | |
| MF01 | | MF02 | 01 | 14.26.05 | dia 10 (fixed bearing end) | 01 | 07 | 13 | 19 | 01 | 02 | 03 | 04 | | |
| with side drive with timing belt, with or without motor | | | | | | | | | | | | | | | |
| RV01 | | RV02 | | | | | | | dia 11 (floating bearing end) | 03 | 09 | 01 | 02 | 03 | 04 |
| RV03 | | RV04 | 01 | 14.26.75 | | | | | | | | | | | |
| | | | | 14.26.90 | | | | | | | | | | | |
| RV05 | | RV06 | | 14.26.55 | | | | | | | | | | | |
| | | | | 14.26.70 | | | | | dia 14 (floating bearing end) | 15 | 21 | 01 | 02 | 03 | 04 |

Please check whether the selected combination is a permissible one (load capacities, moments, maximum speeds, motor data, etc.)!

| Motor attachment = .. | | Motor = .. | Cover = .. | Position measuring system = .. | 1st switch = .. ± mm 2nd switch = .. ± mm 3rd switch = .. ± mm Cable duct = .. - mm Socket-plug = .. Switching cam = .. | | Documentation = .. |
|-----------------------|------------------------|-----------------------------------|---|-------------------------------------|--|--------------------------------|--------------------|
| i = | | Mounting direction as per diagram | Motor type | Polyurethane bellows with- out with | Glass scale with- out with | Standard report Special report | |
| | OA01 | 00 | without | 00 | 00 | on request | |
| | OF01-OF04 | 00 | | | 00 | | |
| 1 | MF01-MF02 | 02 06 | without MKD 41B without MMD 082A | 00 10 00 60 | | | |
| 1 | RV01-RV04 RV05-RV06 | 41 42 | without | 00 | 00 | 01 | 00 |
| 1.5 | RV01-RV04 RV05-RV06 | 43 44 | MKD 41B | 10 | | | |
| 1 | RV01-RV04 RV05-RV06 | 29 30 | without | 00 | | | |
| 2 | RV01-RV04 RV05-RV06 | 31 32 | MHD71A-061 | 61 | | | |
| 1 | RV01-RV04 RV05-RV06 | 53 54 | without | 00 | | | |
| 1.5 | RV01-RV04 RV05-RV06 | 55 56 | MMD 082A | 60 | | | |
| 1 | RV01-RV04 RV05-RV06 | 45 46 | without | 00 | | | |
| 1.5 | RV01-RV04 RV05-RV06 | 47 48 | MKD 41B | 10 | | | |
| 1 | RV01-RV04 RV05-RV06 | 37 38 | without | 00 | | | |
| 2 | RV01-RV04 RV05-RV06 | 39 40 | MHD71A-061 | 61 | | | |
| 1 | RV01-RV04 RV05-RV06 | 49 50 | without | 00 | | | |
| 1.5 | RV01-RV04 RV05-RV06 | 51 52 | MMD 082A | 60 | | | |

without switch
without cable duct 00

Direction: - 0 +
Reference edge
Switch
L/2

External switch:
PNP NC 11 - A ± ...
PNP NO 13 - A ± ...
Mechanical 15 - A ± ...

Switch type
Pos. and direction
Switch activation point in mm

External switching cam 16

External socket-plug (loose) 17

Cable duct (loose)
Cable duct 20 - X ...

Type
Length in mm

02 Friction moment

03 Lead deviation

04 Sequence accuracy

05 Positioning accuracy

STAR – Aluminum Ball Rail® Tables

TKK 15-155 Al Dimension Drawings



| Length L (mm) | Counterbored mounting hole spacing F - G x 120 - F | Max. travel for carriage length* | | | |
|------------------|---|-------------------------------------|------|-----------------|------|
| | | with bellows | | without bellows | |
| | | 150* | 220* | 150* | 220* |
| 220 | 50 - 1 x 120 - 50 | - | - | 60 | - |
| 280 | 20 - 2 x 120 - 20 | 68 | - | 120 | - |
| 340 | 50 - 2 x 120 - 50 | 117 | 59 | 180 | 110 |
| 400 | 20 - 3 x 120 - 20 | 166 | 109 | 240 | 170 |
| 460 | 50 - 3 x 120 - 50 | 216 | 158 | 300 | 230 |
| 520 | 20 - 4 x 120 - 20 | 265 | 207 | 360 | 290 |
| 580 | 50 - 4 x 120 - 50 | 315 | 257 | 420 | 350 |
| 640 | 20 - 5 x 120 - 20 | 364 | 306 | 480 | 410 |
| 700 | 50 - 5 x 120 - 50 | 414 | 356 | 540 | 470 |
| 760 | 20 - 6 x 120 - 20 | 463 | 405 | 600 | 530 |
| 820 | 50 - 6 x 120 - 50 | 512 | 454 | 660 | 590 |
| 880 | 20 - 7 x 120 - 20 | 562 | 504 | 720 | 650 |
| 940 | 50 - 7 x 120 - 50 | 611 | 553 | 780 | 710 |
| 1000 | 20 - 8 x 120 - 20 | 661 | 603 | 840 | 770 |
| 1060 | 50 - 8 x 120 - 50 | 710 | 652 | 900 | 830 |
| 1120 | 20 - 9 x 120 - 20 | 759 | 702 | 960 | 890 |
| 1180 | 50 - 9 x 120 - 50 | 809 | 751 | 1020 | 950 |
| 1240 | 20 - 10 x 120 - 20 | 858 | 800 | 1080 | 1010 |
| 1300 | 50 - 10 x 120 - 50 | 908 | 850 | 1140 | 1070 |
| 1360 | 20 - 11 x 120 - 20 | 957 | 899 | 1200 | 1130 |
| 1420 | 50 - 11 x 120 - 50 | 1007 | 949 | 1260 | 1190 |
| 1480 | 20 - 12 x 120 - 20 | 1056 | 998 | 1320 | 1250 |
| 1540 | 50 - 12 x 120 - 50 | 1105 | 1048 | 1380 | 1310 |

| Length L (mm) | Counterbored mounting hole spacing F - G x 120 - F | Max. travel for carriage length* | | | |
|------------------|---|-------------------------------------|------|-----------------|------|
| | | with bellows | | without bellows | |
| | | 150* | 220* | 150* | 220* |
| 1600 | 20 - 13 x 120 - 20 | 1155 | 1097 | 1440 | 1370 |
| 1660 | 50 - 13 x 120 - 50 | 1204 | 1146 | 1500 | 1430 |
| 1720 | 20 - 14 x 120 - 20 | 1254 | 1196 | 1560 | 1490 |
| 1780 | 50 - 14 x 120 - 50 | 1303 | 1245 | 1620 | 1550 |
| 1840 | 20 - 15 x 120 - 20 | 1353 | 1295 | 1680 | 1610 |
| 1900 | 50 - 15 x 120 - 50 | 1402 | 1344 | 1740 | 1670 |
| 1960 | 20 - 16 x 120 - 20 | 1451 | 1394 | 1800 | 1730 |
| 2020 | 50 - 16 x 120 - 50 | 1501 | 1443 | 1860 | 1790 |
| 2080 | 20 - 17 x 120 - 20 | 1550 | 1492 | 1920 | 1850 |
| 2140 | 50 - 17 x 120 - 50 | 1600 | 1542 | 1980 | 1910 |
| 2200 | 20 - 18 x 120 - 20 | 1649 | 1591 | 2040 | 1970 |
| 2260 | 50 - 18 x 120 - 50 | 1699 | 1641 | 2100 | 2030 |
| 2320 | 20 - 19 x 120 - 20 | 1748 | 1690 | 2160 | 2090 |
| 2380 | 50 - 19 x 120 - 50 | 1797 | 1739 | 2220 | 2150 |
| 2440 | 20 - 20 x 120 - 20 | 1847 | 1789 | 2280 | 2210 |
| 2500 | 50 - 20 x 120 - 50 | 1896 | 1838 | 2340 | 2270 |
| 2560 | 20 - 21 x 120 - 20 | 1946 | 1888 | 2400 | 2330 |
| 2620 | 50 - 21 x 120 - 50 | 1995 | 1937 | 2460 | 2390 |
| 2680 | 20 - 22 x 120 - 20 | 2045 | 1987 | 2520 | 2450 |
| 2740 | 50 - 22 x 120 - 50 | 2094 | 2036 | 2580 | 2510 |
| 2800 | 20 - 23 x 120 - 20 | 2143 | 2085 | 2640 | 2570 |
| 2860 | 50 - 23 x 120 - 50 | 2193 | 2135 | 2700 | 2630 |



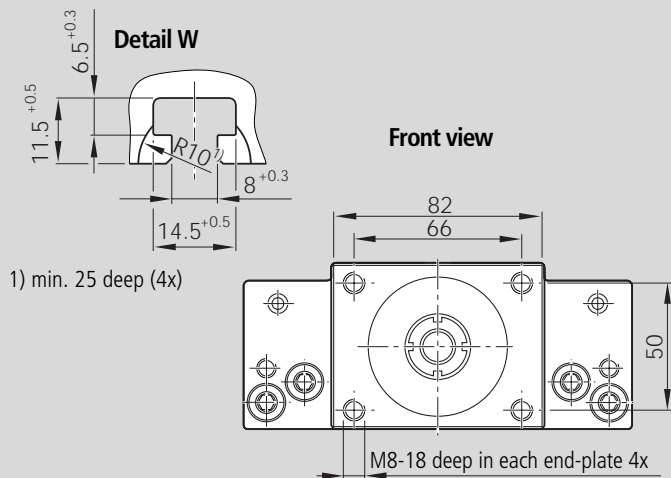
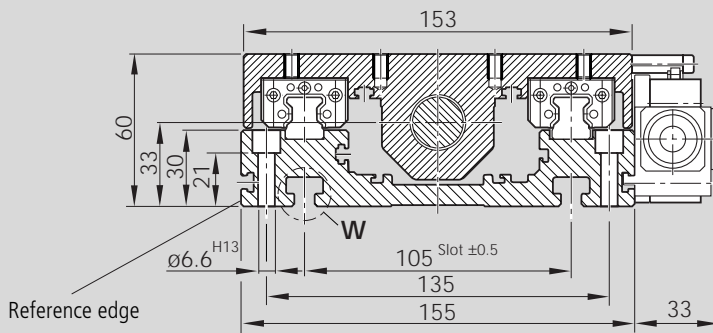

Mounting hole pattern for carriage length $L_T = 150$

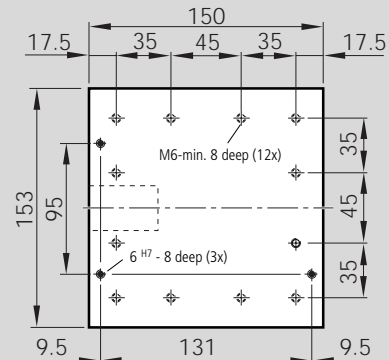

Mounting hole pattern for carriage length $L_T = 220$

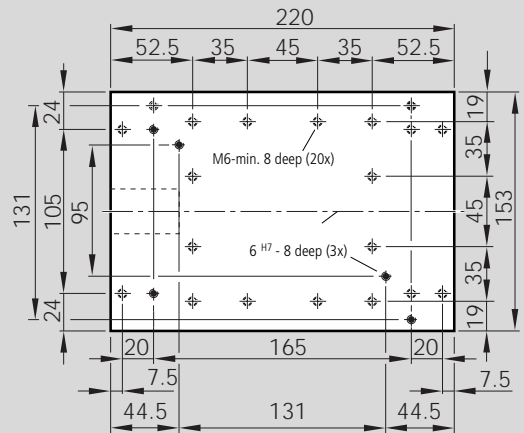

Effective stroke

For safe operation, the excess travel must be longer than the braking distance. The acceleration travel can be taken as guideline value for the braking distance. In most cases, 2x the ball screw lead (P) will be sufficient.

Example for $P = 20$ mm:

Excess travel (braking distance) ≈ 40 mm

Recommended standard configuration:

- 2 mechanical switches
- 1 proximity switch

$$\text{Effective stroke} = \text{max. travel} - 2 \cdot \text{excess travel}$$

Distance between switch activation points of two switches

| Switch position | For switch combination | Min. spacing (mm) |
|-----------------|-------------------------|-------------------|
| external | mechanical - mechanical | 60 |
| | mechanical - proximity | 45 |
| | proximity - proximity | 12.5 |

Maximum switch activation point

The switch activation point characterizes the position of the center of the carriage after travel. The zero point is at $L/2$.

$$\text{Maximum switch activation point} = 0.5 \cdot \text{max. travel} - \text{excess travel}$$

STAR – Aluminum Ball Rail® Tables TKK 15-155 Al Dimension Drawings

Motor attachment with motor mount and coupling

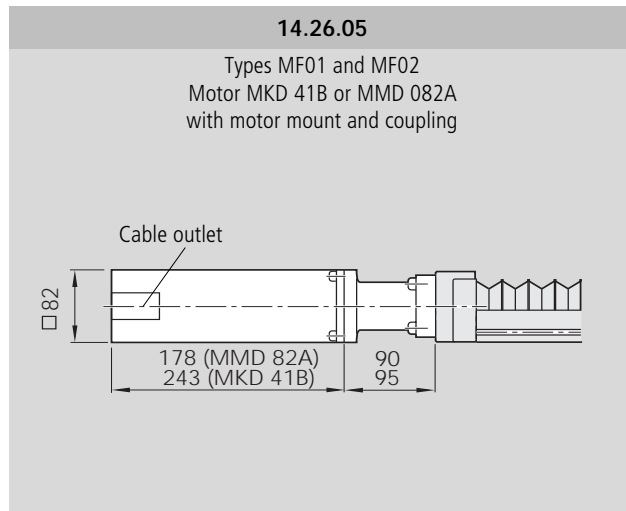

Motor attachment for side drive with timing belt

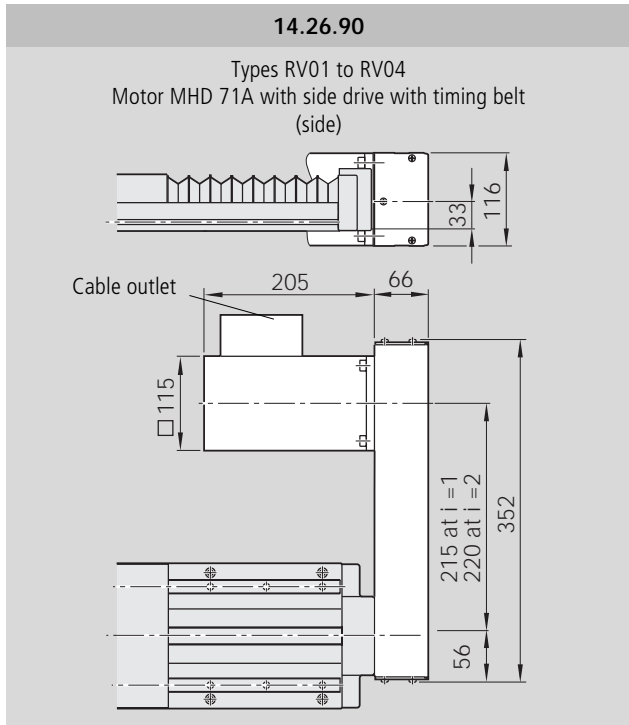
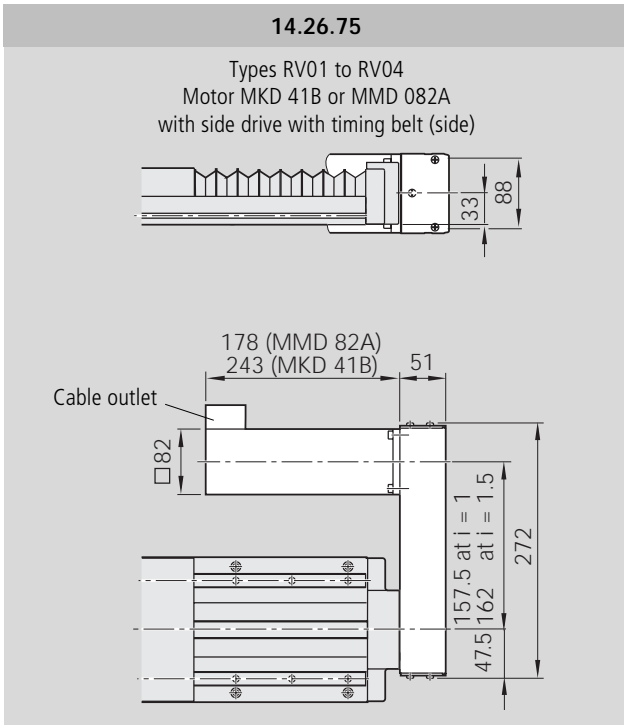
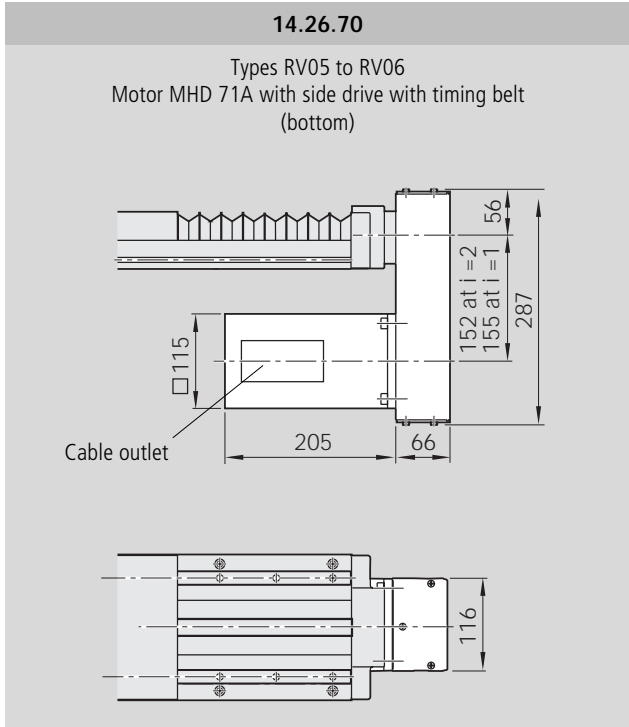
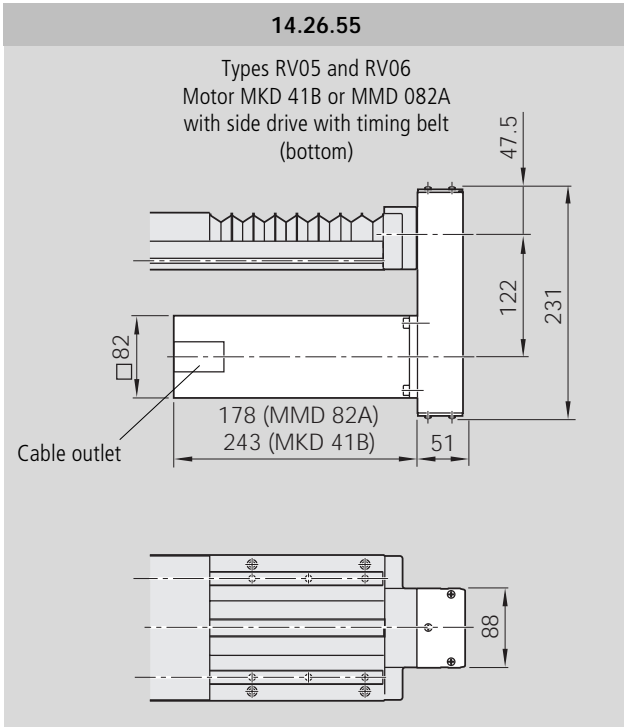

For motor dimensions see "Motors"

Note for multi-axis units (e.g. cross-tables)

For multi-axis units with motor attachment via side drive with timing belt, the motor may project into the working area of adjacent axes. Check for any interference contours.

STAR – Aluminum Ball Rail® Tables

TKK 20-225 Al Options Table

| Part number 1460-305-00, mm See dimensions table for length | | Type | Guide-way = .. | Drive unit = .. | | | | | Carriage = .. | | | | | |
|--|----------------------------------|-----------|---------------------------------|--------------------|-----------------------------------|------------------|--------|---------|--------------------------------|-------------------------|----|-------------------------|----|----|
| <p>Internal switch External switch Reference edge Switch side Dimension drawing no. for motor attachment</p> | | | <p>Base plate flat high</p> | Ball screw journal | | Ball screw drive | | | Carriage length L _T | | | | | |
| | | | | keyway | 20 x 5 | 20 x 20 | 25 x 5 | 25 x 10 | 25 x 25 | 220 mm Preload 2% 8% | | 320 mm Preload 2% 8% | | |
| without drive unit (without end-plates) | | | | | | | | | | | | | | |
| OA01 | <p>Reference edge Switch</p> | | 01 | 11 | | | | 00 | | 01 | 02 | 03 | 04 | |
| without motor mount and motor | | | | | | | | | | | | | | |
| OF01 | <p>Reference edge Switch</p> | | 01 | 11 | dia 10 (fixed brg.) | 01 | 07 | | | | | | | |
| OF04 | <p>Reference edge Switch</p> | | | | dia 10 keyway (fixed bearing end) | 04 | 10 | | | | 01 | 02 | 03 | 04 |
| | | | | | dia 14 (fixed brg.) | | | 13 | 19 | | | | | |
| | | | | | dia 14 keyway (fixed bearing end) | | | 16 | 22 | | | | | |
| | | | | | dia 14 (fixed brg.) | | | | | 25 | | | | |
| | | | dia 14 (fixed brg.) | | | | | 28 | 05 | 06 | 07 | 08 | | |
| with motor mount and coupling, with or without motor | | | | | | | | | | | | | | |
| MF01 | <p>Reference edge Switch</p> | | 01 | 11 | dia 10 (fixed bearing end) | 01 | 07 | | | 01 | 02 | 03 | 04 | |
| MF02 | <p>Reference edge Switch</p> | | | | dia 14 (fixed bearing end) | | | 13 | 19 | | 01 | 02 | 03 | 04 |
| | | | | | | | | 25 | 05 | 06 | 07 | 08 | | |
| with side drive with timing belt, with or without motor | | | | | | | | | | | | | | |
| RV01 | <p>Reference edge Switch</p> | | 01 | 11 | dia 14 (floating bearing end) | 03 | 09 | 15 | 21 | 01 | 02 | 03 | 04 | |
| RV02 | <p>Reference edge Switch</p> | | | | | | | | | | | | | |
| RV03 | <p>Reference edge Switch</p> | | | | | | | | | | | | | |
| RV04 | <p>Reference edge Switch</p> | | | | | | | | | | | | | |
| RV05 | <p>Reference edge Switch</p> | | | | | | | | 27 | 05 | 06 | 07 | 08 | |
| RV06 | <p>Reference edge Switch</p> | | | | | | | | | | | | | |

Please check whether the selected combination is a permissible one (load capacities, moments, maximum speeds, motor data, etc.)!

| Motor attachment = .. | | Motor = .. | Cover = .. | Position measuring system = .. | 1st switch = .. ± mm 2nd switch = .. ± mm 3rd switch = .. ± mm Cable duct = .. - mm Socket-plug = .. Switching cam = .. | | Documentation = .. |
|-----------------------|-----------------------------------|---------------------|--|---------------------------------|--|----------------|-------------------------|
| | | | | | | | |
| i = | Mounting direction as per diagram | Motor type | Polyurethane bellows with-out with | Glass scale with-out with | Standard report | Special report | |
| | OA01 00 | without 00 | 00 on request | | | | 02 Friction moment |
| | OF01-OF04 00 | without 00 | | | | | 03 Lead deviation |
| 1 | MF01-MF02 10 | without 00 | 00 01 00 on request | | | | 01 |
| | | MMD 082A 60 | | | | | |
| | | 02 without 00 | | | | | |
| | | 04 MKD 41B 10 | | | | | |
| 1 | MF01-MF02 06 | without 00 | | | | | 04 Sequence accuracy |
| | | MKD 71B-061 11 | | | | | |
| | | MHD 71B-061 62 | | | | | |
| | | 11 without 00 | | | | | |
| | | MMD 082A 60 | | | | | |
| 1 | RV01-RV04 37 | without 00 | | | | | 05 Positioning accuracy |
| | RV05-RV06 38 | | | | | | |
| 2 | RV01-RV04 39 | MHD 71A-061 61 | | | | | |
| | RV05-RV06 40 | | | | | | |
| 1 | RV01-RV04 45 | without 00 | | | | | |
| | RV05-RV06 46 | | | | | | |
| 1.5 | RV01-RV04 47 | MKD 41B 10 | | | | | |
| | RV05-RV06 48 | | | | | | |
| 1 | RV01-RV04 49 | without 00 | | | | | |
| | RV05-RV06 50 | | | | | | |
| 1.5 | RV01-RV04 51 | MMD 082A 60 | | | | | |
| | RV05-RV06 52 | | | | | | |

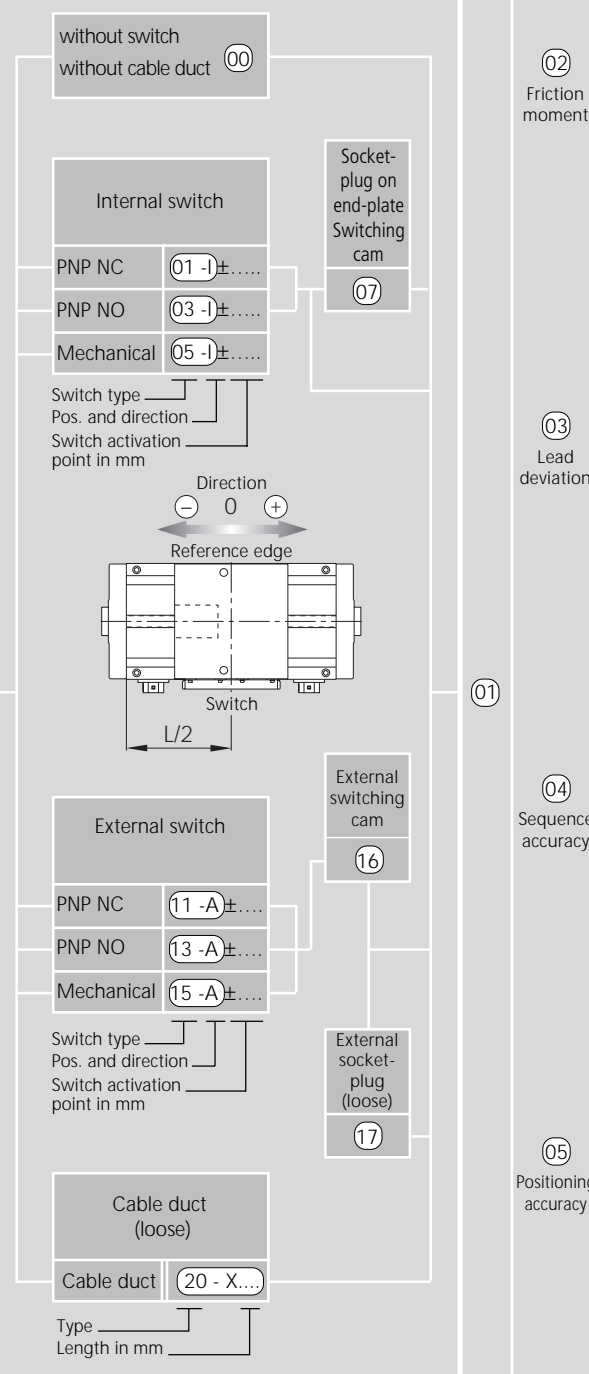

STAR – Aluminum Ball Rail® Tables

TKK 20-225 Al Dimension Drawings

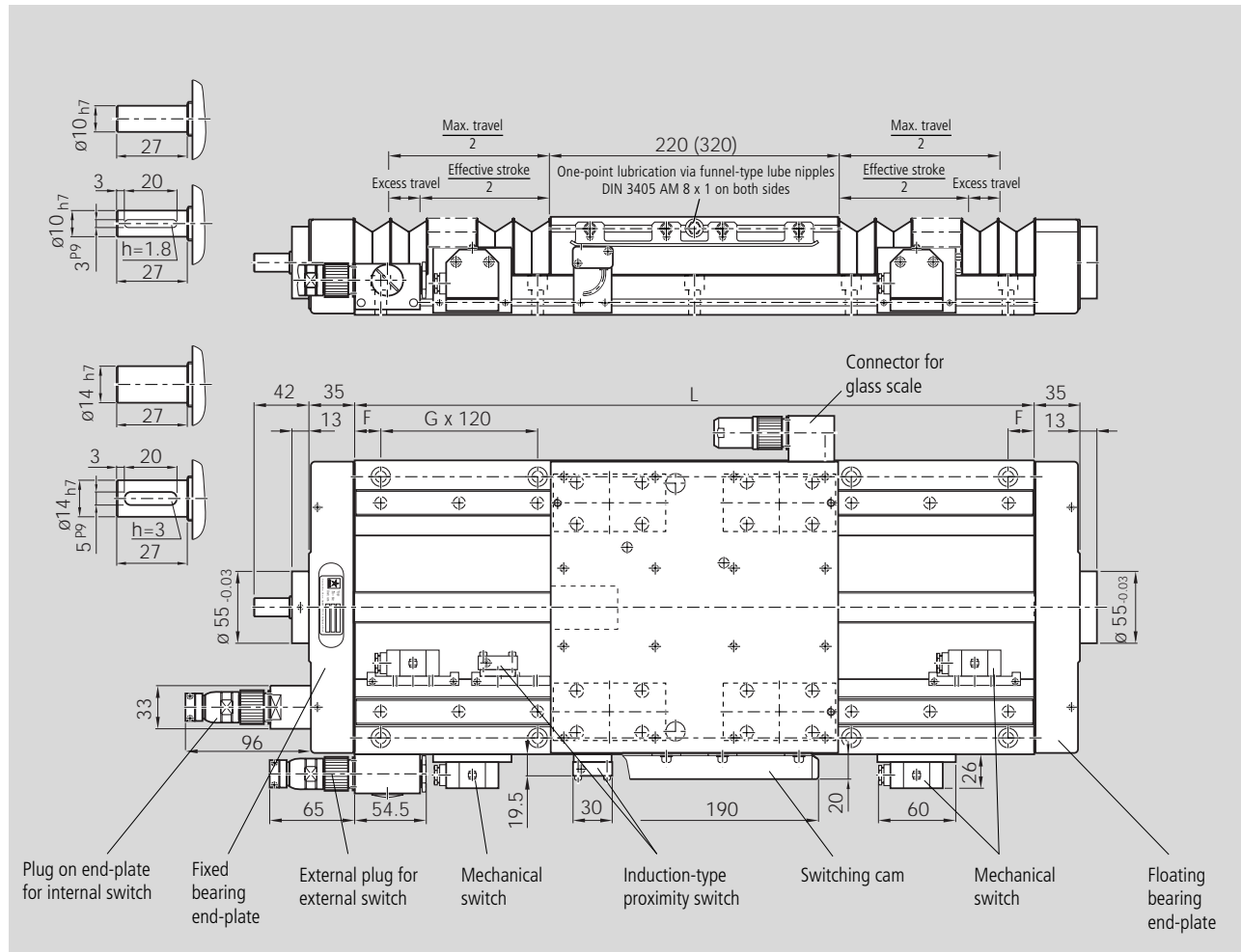

| Length L (mm) | Counterbored mounting hole spacing F - G x 120 - F | Max. travel for carriage length* | | | |
|------------------|---|-------------------------------------|------|-----------------|------|
| | | with bellows | | without bellows | |
| | | 220* | 320* | 220* | 320* |
| 340 | 50 - 2 x 120 - 50 | 70 | - | 110 | - |
| 400 | 20 - 3 x 120 - 20 | 122 | 34 | 170 | 70 |
| 460 | 50 - 3 x 120 - 50 | 174 | 86 | 230 | 130 |
| 520 | 20 - 4 x 120 - 20 | 226 | 138 | 290 | 190 |
| 580 | 50 - 4 x 120 - 50 | 278 | 190 | 350 | 250 |
| 640 | 20 - 5 x 120 - 20 | 330 | 242 | 410 | 310 |
| 700 | 50 - 5 x 120 - 50 | 382 | 294 | 470 | 370 |
| 760 | 20 - 6 x 120 - 20 | 434 | 346 | 530 | 430 |
| 820 | 50 - 6 x 120 - 50 | 486 | 398 | 590 | 490 |
| 880 | 20 - 7 x 120 - 20 | 538 | 450 | 650 | 550 |
| 940 | 50 - 7 x 120 - 50 | 590 | 502 | 710 | 610 |
| 1000 | 20 - 8 x 120 - 20 | 642 | 554 | 770 | 670 |
| 1060 | 50 - 8 x 120 - 50 | 694 | 606 | 830 | 730 |
| 1120 | 20 - 9 x 120 - 20 | 746 | 658 | 890 | 790 |
| 1180 | 50 - 9 x 120 - 50 | 798 | 710 | 950 | 850 |
| 1240 | 20 - 10 x 120 - 20 | 850 | 762 | 1010 | 910 |
| 1300 | 0 - 10 x 120 - 50 | 902 | 814 | 1070 | 970 |
| 1360 | 20 - 11 x 120 - 20 | 954 | 866 | 1130 | 1030 |
| 1420 | 50 - 11 x 120 - 50 | 1006 | 918 | 1190 | 1090 |
| 1480 | 20 - 12 x 120 - 20 | 1058 | 970 | 1250 | 1150 |
| 1540 | 50 - 12 x 120 - 50 | 1110 | 1022 | 1310 | 1210 |
| 1600 | 20 - 13 x 120 - 20 | 1162 | 1074 | 1370 | 1270 |

| Length L (mm) | Counterbored mounting hole spacing F - G x 120 - F | Max. travel for carriage length* | | | |
|------------------|---|-------------------------------------|------|-----------------|------|
| | | with bellows | | without bellows | |
| | | 220* | 320* | 220* | 320* |
| 1660 | 50 - 13 x 120 - 50 | 1214 | 1126 | 1430 | 1330 |
| 1720 | 20 - 14 x 120 - 20 | 1266 | 1178 | 1490 | 1390 |
| 1780 | 50 - 14 x 120 - 50 | 1318 | 1230 | 1550 | 1450 |
| 1840 | 20 - 15 x 120 - 20 | 1370 | 1282 | 1610 | 1510 |
| 1900 | 50 - 15 x 120 - 50 | 1422 | 1334 | 1670 | 1570 |
| 1960 | 20 - 16 x 120 - 20 | 1474 | 1386 | 1730 | 1630 |
| 2020 | 50 - 16 x 120 - 50 | 1526 | 1438 | 1790 | 1690 |
| 2080 | 20 - 17 x 120 - 20 | 1578 | 1490 | 1850 | 1750 |
| 2140 | 50 - 17 x 120 - 50 | 1630 | 1542 | 1910 | 1810 |
| 2200 | 20 - 18 x 120 - 20 | 1682 | 1594 | 1970 | 1870 |
| 2260 | 50 - 18 x 120 - 50 | 1734 | 1646 | 2030 | 1930 |
| 2320 | 20 - 19 x 120 - 20 | 1786 | 1698 | 2090 | 1990 |
| 2380 | 50 - 19 x 120 - 50 | 1838 | 1750 | 2150 | 2050 |
| 2440 | 20 - 20 x 120 - 20 | 1890 | 1802 | 2210 | 2110 |
| 2500 | 50 - 20 x 120 - 50 | 1942 | 1854 | 2270 | 2170 |
| 2560 | 20 - 21 x 120 - 20 | 1994 | 1906 | 2330 | 2230 |
| 2620 | 50 - 21 x 120 - 50 | 2046 | 1958 | 2390 | 2290 |
| 2680 | 20 - 22 x 120 - 20 | 2098 | 2010 | 2450 | 2350 |
| 2740 | 50 - 22 x 120 - 50 | 2150 | 2062 | 2510 | 2410 |
| 2800 | 20 - 23 x 120 - 20 | 2202 | 2114 | 2570 | 2470 |
| 2860 | 50 - 23 x 120 - 50 | 2254 | 2166 | 2630 | 2530 |



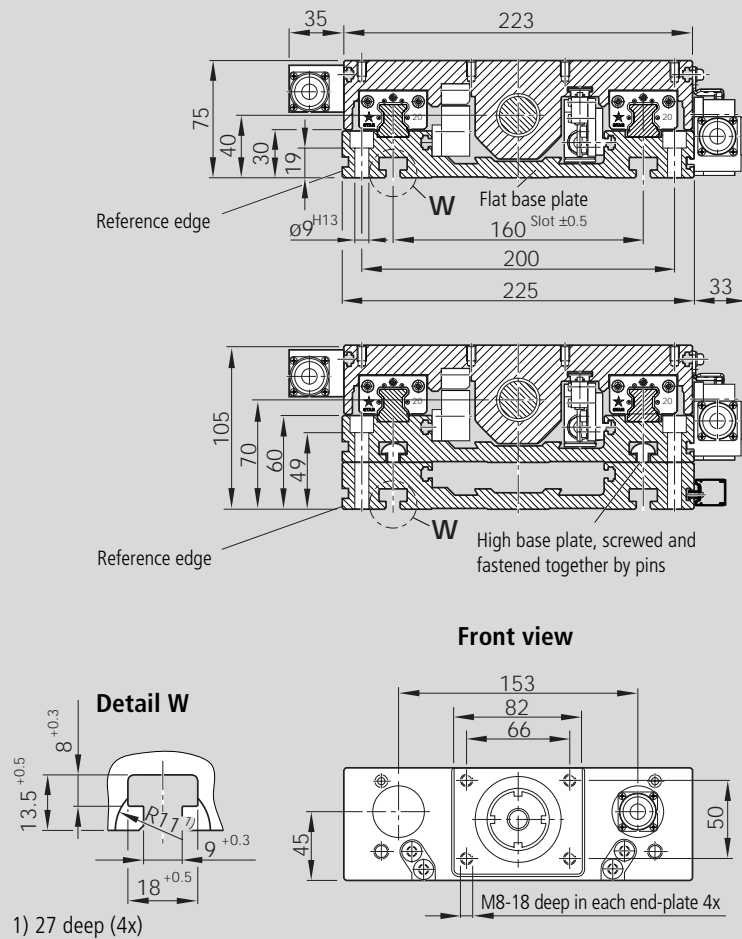

Mounting hole pattern for carriage length

$L_T = 220$

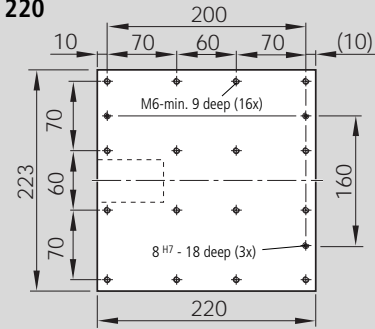

Mounting hole pattern for carriage length

$L_T = 320$

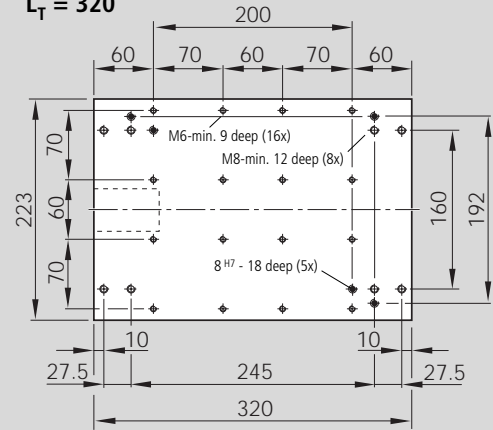

Effective stroke

For safe operation, the excess travel must be longer than the braking distance. The acceleration travel can be taken as guideline value for the braking distance. In most cases, 2x the ball screw lead (P) will be sufficient.

Example for $P = 25$ mm:
Excess travel (braking distance) ≈ 50 mm

Recommended standard configuration:
– 2 mechanical switches
– 1 proximity switch

$$\text{Effective stroke} = \text{max. travel} - 2 \cdot \text{excess travel}$$

Distance between switch activation points of two switches

| Switch position | For switch combination | Min. spacing (mm) |
|-----------------|-------------------------|-------------------|
| external | mechanical - mechanical | 60 |
| | mechanical - proximity | 45 |
| | proximity - proximity | 12.5 |
| internal | mechanical - mechanical | 70 |
| | mechanical - proximity | 50 |
| | proximity - proximity | 25 |

Maximum switch activation point

The switch activation point characterizes the position of the center of the carriage after travel. The zero point is at $L/2$.

$$\text{Maximum switch activation point} = 0.5 \cdot \text{max. travel} - \text{excess travel}$$

STAR – Steel Ball Rail Tables

TKK 20-225 St Options Table

| Part number 1460-300-00, ... mm See dimensions table for length | | Type ... | Guide-way = .. | Drive unit = .. | | | | Carriage = .. | | | | | | |
|---|--|--|----------------|-----------------------------------|--------|------------------|--------|-----------------------------|-------------------------|----|-------------------------|----|----|--|
| | | Dimension drawing no. for motor attachment | | | | | | | | | | | | |
| | | | Base plate | Ball screw journal | | Ball screw drive | | Table length L _T | | | | | | |
| | | | flat | keyway | 20 x 5 | 20 x 20 | 25 x 5 | 25 x 10 | 220 mm Preload 2% 8% | | 320 mm Preload 2% 8% | | | |
| without drive unit (without end-plates) | | | | | | | | | | | | | | |
| OA01 | | | 01 | | | | | 00 | | 01 | 02 | 03 | 04 | |
| without motor mount and motor | | | | | | | | | | | | | | |
| OF01 | | | 01 | dia 10 (fixed bearing end) | 01 | 07 | | | | | | | | |
| OF04 | | | | dia 10 keyway (fixed bearing end) | 04 | 10 | | | | | | | | |
| | | | | dia 14 (fixed bearing end) | | | 13 | 19 | 01 | 02 | 03 | 04 | | |
| | | | | dia 14 keyway (fixed bearing end) | | | 16 | 22 | | | | | | |
| with motor mount and coupling, with or without motor | | | | | | | | | | | | | | |
| MF01 | | 14.36.05 14.36.20 | 01 | dia 10 (fixed bearing end) | 01 | 07 | | | 01 | 02 | 03 | 04 | | |
| MF02 | | | | dia 14 (fixed bearing end) | | | 13 | 19 | 01 | 02 | 03 | 04 | | |
| with side drive with timing belt, with or without motor | | | | | | | | | | | | | | |
| RV01 | | | 01 | dia 14 (floating bearing end) | | | | | | | | | | |
| RV02 | | 14.36.75 | | | | | | | | | | | | |
| RV03 | | | | | | | | | | | | | | |
| RV04 | | 14.36.90 | | | | | | | | | | | | |
| RV05 | | | | | | | | | | | | | | |
| RV06 | | 14.36.55 14.36.70 | | | | | | | | | | | | |

Please check whether the selected combination is a permissible one (load capacities, moments, maximum speeds, motor data, etc.)!

| Motor attachment = .. | | Motor = .. | Cover = .. | Position measuring system = .. | 1st switch = .. ± mm 2nd switch = .. ± mm 3rd switch = .. ± mm Cable duct = .. - mm Socket-plug = .. Switching cam = .. | | | | Documentation = .. |
|-----------------------|-----------------------------------|------------|--|--------------------------------|--|------------|-----------------------------------|------------|--------------------|
| | | | | | | | | | |
| i = | Mounting direction as per diagram | Motor type | Polyurethane bellows with-out with | | Glass scale with-out with | | Standard report Special report | | |
| | OA01 | 00 | without | 00 | 00 | on request | | | |
| | OF01-OF04 | 00 | without | 00 | | | | | |
| 1 | MF01-MF02 | 10 | without | 00 | | | | | |
| | | 02 | MMD 082A | 60 | | | | | |
| | | 04 | without | 00 | | | | | |
| | | | MKD 41B | 10 | | | | | |
| 1 | MF01-MF02 | 06 | without | 00 | 00 | 01 | 00 | on request | |
| | | | MKD 71B-061 | 11 | | | | | |
| | | | MHD 71B-061 | 62 | | | | | |
| | | 11 | without | 00 | | | | | |
| | | | MMD 082A | 60 | | | | | |
| 1 | RV01-RV04 | 37 | without | 00 | | | | | |
| | RV05-RV06 | 38 | | | | | | | |
| 2 | RV01-RV04 | 39 | | | | | | | |
| | RV05-RV06 | 40 | MHD 71A-061 | 61 | | | | | |
| 1 | RV01-RV04 | 45 | without | 00 | | | | | |
| | RV05-RV06 | 46 | | | | | | | |
| 1.5 | RV01-RV04 | 47 | | | | | | | |
| | RV05-RV06 | 48 | MKD 41B | 10 | | | | | |
| 1 | RV01-RV04 | 49 | without | 00 | | | | | |
| | RV05-RV06 | 50 | | | | | | | |
| 1.5 | RV01-RV04 | 51 | | | | | | | |
| | RV05-RV06 | 52 | MMD 082A | 60 | | | | | |

| | | | | |
|---|--|--|---|------------------------------|
| without switch without cable duct | 00 | Internal switch PNP NC 01 -) ± PNP NO 03 -) ± Mechanical 05 -) ± Switch type Pos. and direction Switch activation point in mm | Socket-plug on end-plate Switching cam | 07 |
| External switch PNP NC 11 -A) ± PNP NO 13 -A) ± Mechanical 15 -A) ± Switch type Pos. and direction Switch activation point in mm | External switching cam with profiled support | | | 26 |
| Cable duct (loose) Cable duct 20 - X.... Type Length in mm | | | | External socket-plug (loose) |

| | |
|----|----------------------|
| 02 | Friction moment |
| 03 | Lead deviation |
| 01 | |
| 04 | Sequence accuracy |
| 05 | Positioning accuracy |

STAR – Steel Ball Rail Tables

TKK 20-225 St Dimension Drawings

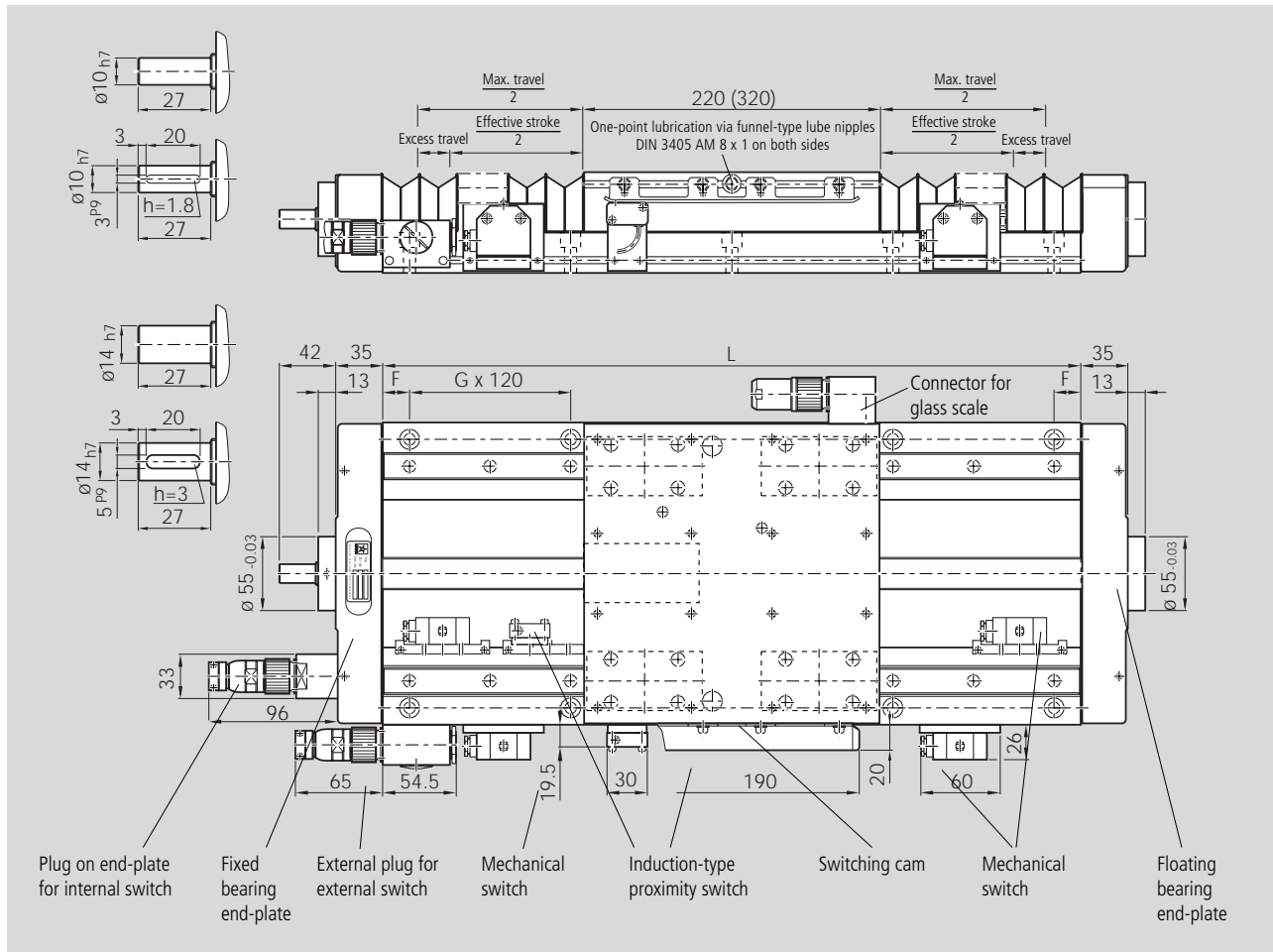

| Length L (mm) | Counterbored mounting hole spacing F - G x 120 - F | Max. travel for carriage length* | | | |
|------------------|---|-------------------------------------|------|-----------------|------|
| | | with bellows | | without bellows | |
| | | 220* | 320* | 220* | 320* |
| 340 | 50 - 2 x 120 - 50 | 70 | - | 110 | - |
| 400 | 20 - 3 x 120 - 20 | 122 | 34 | 170 | 70 |
| 460 | 50 - 3 x 120 - 50 | 174 | 86 | 230 | 130 |
| 520 | 20 - 4 x 120 - 20 | 226 | 138 | 290 | 190 |
| 580 | 50 - 4 x 120 - 50 | 278 | 190 | 350 | 250 |
| 640 | 20 - 5 x 120 - 20 | 330 | 242 | 410 | 310 |
| 700 | 50 - 5 x 120 - 50 | 382 | 294 | 470 | 370 |
| 760 | 20 - 6 x 120 - 20 | 434 | 346 | 530 | 430 |
| 820 | 50 - 6 x 120 - 50 | 486 | 398 | 590 | 490 |
| 880 | 20 - 7 x 120 - 20 | 538 | 450 | 650 | 550 |
| 940 | 50 - 7 x 120 - 50 | 590 | 502 | 710 | 610 |
| 1000 | 20 - 8 x 120 - 20 | 642 | 554 | 770 | 670 |
| 1060 | 50 - 8 x 120 - 50 | 694 | 606 | 830 | 730 |
| 1120 | 20 - 9 x 120 - 20 | 746 | 658 | 890 | 790 |
| 1180 | 50 - 9 x 120 - 50 | 798 | 710 | 950 | 850 |
| 1240 | 20 - 10 x 120 - 20 | 850 | 762 | 1010 | 910 |
| 1300 | 0 - 10 x 120 - 50 | 902 | 814 | 1070 | 970 |
| 1360 | 20 - 11 x 120 - 20 | 954 | 866 | 1130 | 1030 |
| 1420 | 50 - 11 x 120 - 50 | 1006 | 918 | 1190 | 1090 |
| 1480 | 20 - 12 x 120 - 20 | 1058 | 970 | 1250 | 1150 |
| 1540 | 50 - 12 x 120 - 50 | 1110 | 1022 | 1310 | 1210 |
| 1600 | 20 - 13 x 120 - 20 | 1162 | 1074 | 1370 | 1270 |

| Length L (mm) | Counterbored mounting hole spacing F - G x 120 - F | Max. travel for carriage length* | | | |
|------------------|---|-------------------------------------|------|-----------------|------|
| | | with bellows | | without bellows | |
| | | 220* | 320* | 220* | 320* |
| 1660 | 50 - 13 x 120 - 50 | 1214 | 1126 | 1430 | 1330 |
| 1720 | 20 - 14 x 120 - 20 | 1266 | 1178 | 1490 | 1390 |
| 1780 | 50 - 14 x 120 - 50 | 1318 | 1230 | 1550 | 1450 |
| 1840 | 20 - 15 x 120 - 20 | 1370 | 1282 | 1610 | 1510 |
| 1900 | 50 - 15 x 120 - 50 | 1422 | 1334 | 1670 | 1570 |
| 1960 | 20 - 16 x 120 - 20 | 1474 | 1386 | 1730 | 1630 |
| 2020 | 50 - 16 x 120 - 50 | 1526 | 1438 | 1790 | 1690 |
| 2080 | 20 - 17 x 120 - 20 | 1578 | 1490 | 1850 | 1750 |
| 2140 | 50 - 17 x 120 - 50 | 1630 | 1542 | 1910 | 1810 |
| 2200 | 20 - 18 x 120 - 20 | 1682 | 1594 | 1970 | 1870 |
| 2260 | 50 - 18 x 120 - 50 | 1734 | 1646 | 2030 | 1930 |
| 2320 | 20 - 19 x 120 - 20 | 1786 | 1698 | 2090 | 1990 |
| 2380 | 50 - 19 x 120 - 50 | 1838 | 1750 | 2150 | 2050 |

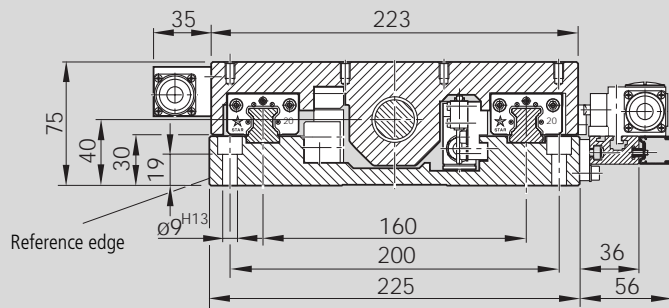

Mounting hole pattern for carriage length

$L_T = 220$

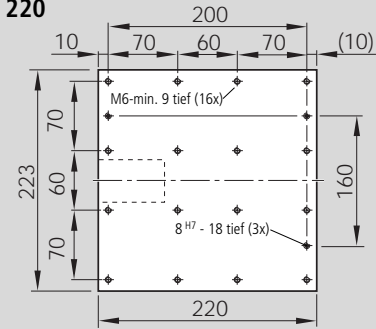

Mounting hole pattern for carriage length

$L_T = 320$

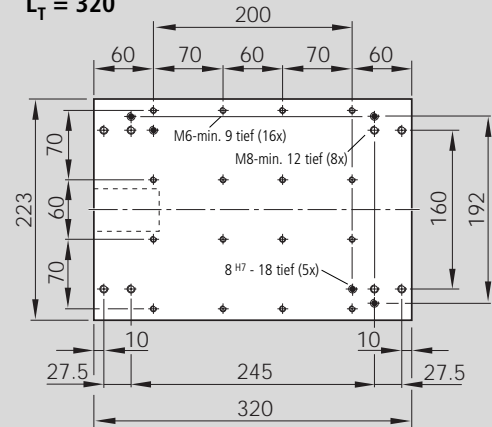

Front view

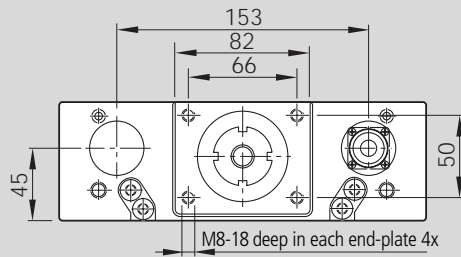

Effective stroke

For safe operation, the excess travel must be longer than the braking distance. The acceleration travel can be taken as guideline value for the braking distance. In most cases, 2x the ball screw lead (P) will be sufficient.

Example for $P = 25$ mm:
Excess travel (braking distance) ≈ 50 mm

Recommended standard configuration:
– 2 mechanical switches
– 1 proximity switch

$$\text{Effective stroke} = \text{max. travel} - 2 \cdot \text{excess travel}$$

Distance between switch activation points of two switches

| Switch position | For switch combination | Min. spacing (mm) |
|-----------------|-------------------------|-------------------|
| external | mechanical - mechanical | 60 |
| | mechanical - proximity | 45 |
| | proximity - proximity | 12.5 |
| internal | mechanical - mechanical | 70 |
| | mechanical - proximity | 50 |
| | proximity - proximity | 25 |

Maximum switch activation point

The switch activation point characterizes the position of the center of the carriage after travel. The zero point is at $L/2$.

$$\text{Maximum switch activation point} = 0.5 \cdot \text{max. travel} - \text{excess travel}$$

STAR – Ball Rail Tables

TKK 20-225 Dimension Drawings, Motor Attachment

Motor attachment with motor mount and coupling

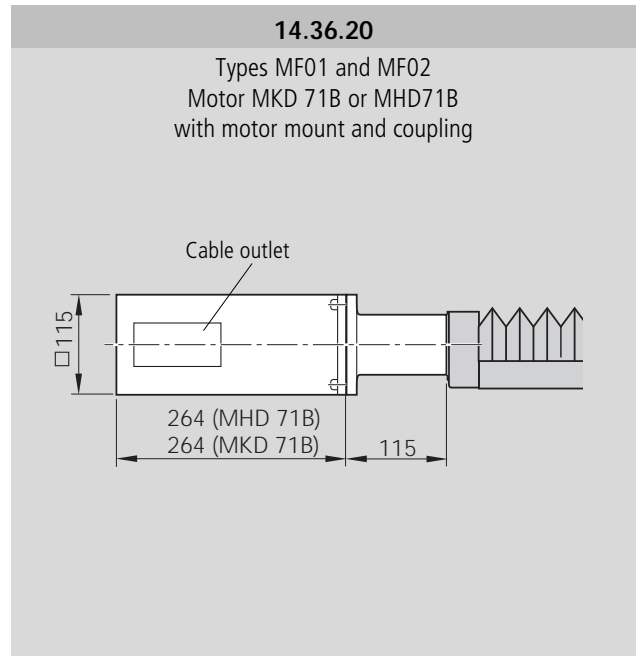
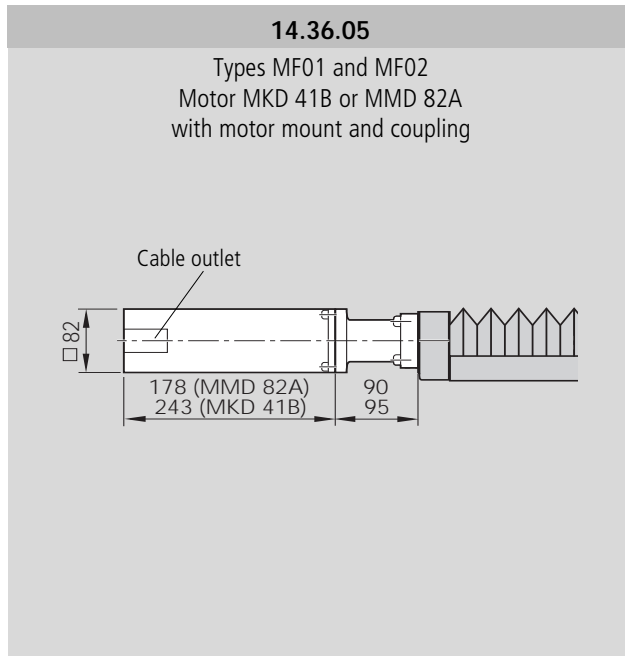

Motor attachment for side drive with timing belt

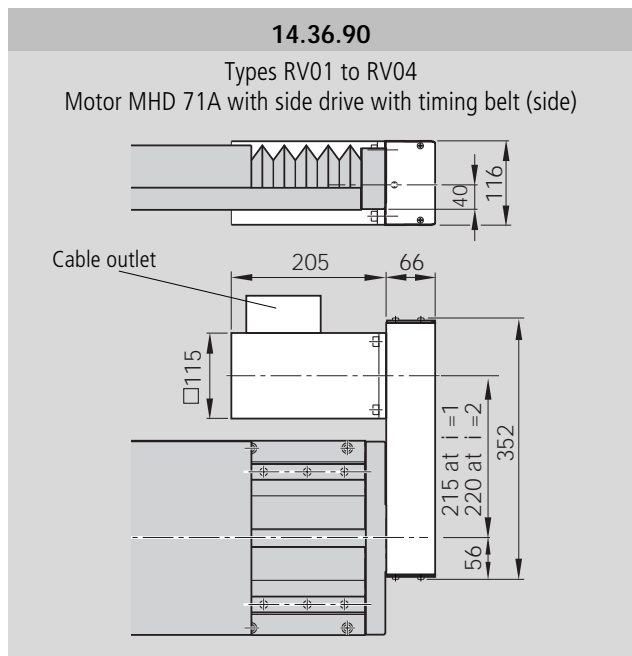
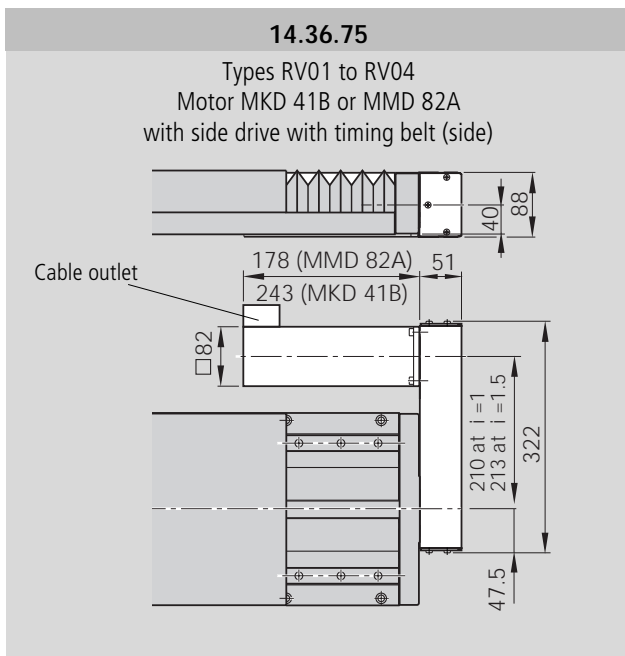
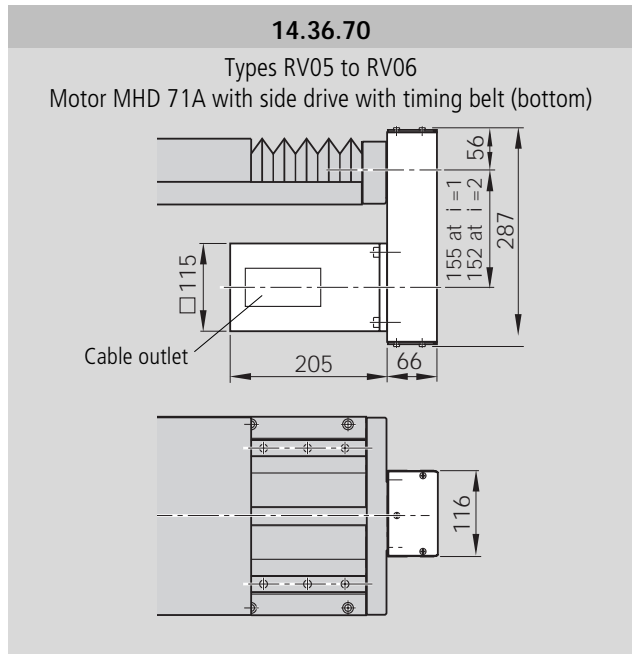
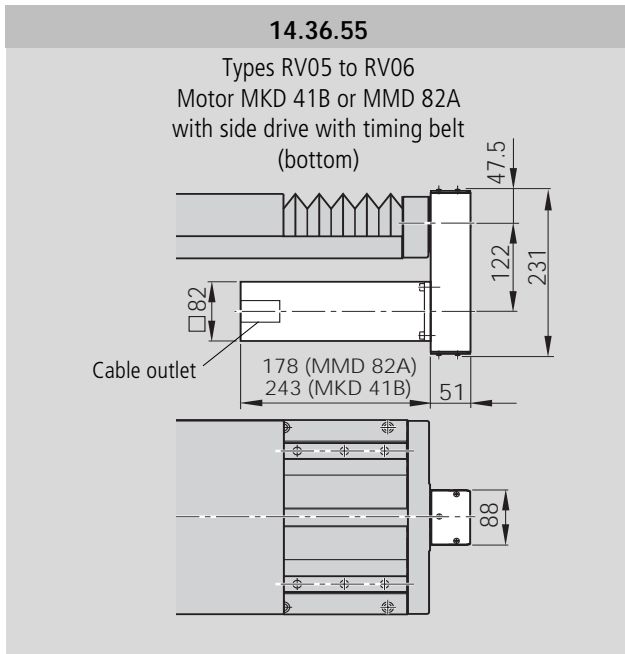

Note for steel version

In version RV01 and RV02 with externally mounted switches:
no switches may be mounted in the motor area!

Note for multi-axis units (e.g. cross-tables)

For multi-axis units with motor attachment via side drive with timing belt, the motor may project into the working area of adjacent axes. Check for any interference contours!

For motor dimensions see "Motors"

STAR – Aluminum Ball Rail® Tables

TKK 30-325 Al Options Table

| Part number 1460-405-00, ... mm See dimensions table for length | | Type ... | Guide-way = .. | Drive unit = .. | | | | Carriage = .. | | | | | | |
|--|--|----------|-------------------|--------------------|----------------------------|-------------------------------|---------|--------------------------------|---------|-------------------------|----|-------------------------|----|----|
| <p>Internal switch External switch</p> <p>Reference edge Switch side</p> <p>Dimension drawing no. for motor attachment</p> | | | | | | | | | | | | | | |
| | | | Base plate | Ball screw journal | | Ball screw drive | | Carriage length L _T | | | | | | |
| | | | flat | high | keyway | 32 x 5 | 32 x 10 | 32 x 20 | 32 x 32 | 320 mm Preload 2% 8% | | 450 mm Preload 2% 8% | | |
| without drive unit (without end-plates) | | | | | | | | | | | | | | |
| OA01 | | | 01 | 11 | | | | | | 05 | 06 | 07 | 08 | |
| without motor mount and motor | | | | | | | | | | | | | | |
| OF01 | | OF04 | 01 | 11 | dia 16 (fixed bearing end) | 07 | 13 | 19 | 25 | 05 | 06 | 07 | 08 | |
| | | | | | dia 16 keyway (fixed brg.) | 10 | 16 | 22 | 28 | | | | | |
| with motor mount and coupling, with or without motor | | | | | | | | | | | | | | |
| MF01 | | | | | | | | | | | | | | |
| MF02 | | | 14.46.20 | 01 | 11 | dia 16 (fixed bearing end) | 07 | 13 | 19 | 25 | 05 | 06 | 07 | 08 |
| with side drive with timing belt, with or without motor | | | | | | | | | | | | | | |
| RV01 | | RV02 | | | | | | | | | | | | |
| RV03 | | RV04 | 14.46.90 | 01 | 11 | dia 16 (floating bearing end) | 09 | 15 | 21 | 27 | 05 | 06 | 07 | 08 |
| RV05 | | RV06 | 14.46.70 | | | | | | | | | | | |

Please check whether the selected combination is a permissible one (load capacities, moments, maximum speeds, motor data, etc.)!

| Motor attachment = .. | | Motor = .. | Cover = .. | Position measuring system = .. | 1st switch = .. ± mm 2nd switch = .. ± mm 3rd switch = .. ± mm Cable duct = .. - mm Socket-plug = .. Switching cam = .. | | Documentation = .. |
|-----------------------|-----------|-----------------------------------|-------------|--------------------------------------|--|----------------------------------|--------------------|
| i = | | Mounting direction as per diagram | Motor type | Polyurethane bellows with-out / with | Glass scale with-out / with | Standard report / Special report | |
| | OA01 | 00 | without | 00 | 00 | on request | |
| | OF01-OF04 | 00 | | 00 | | | |
| 1 | MF01-MF02 | 06 | without | 00 | | | |
| | | | MKD 71B-061 | 11 | | | |
| | | | MHD 71B-061 | 62 | 00 | 01 | 00 on request |
| 1 | RV01-RV04 | 69 | without | 00 | | | |
| | RV05-RV06 | 70 | | | | | |
| 2 | RV01-RV04 | 71 | | | | | |
| | RV05-RV06 | 72 | MHD 71B-061 | 62 | | | |
| 1 | RV01-RV04 | 73 | without | 00 | | | |
| | RV05-RV06 | 74 | | | | | |
| | | | MKD 71B-061 | 11 | | | |
| 2 | RV01-RV04 | 75 | | | | | |
| | RV05-RV06 | 76 | MHD 71B-061 | 62 | | | |

1st switch = .. ± mm
2nd switch = .. ± mm
3rd switch = .. ± mm
Cable duct = .. - mm
Socket-plug = ..
Switching cam = ..

without switch without cable duct 00

Internal switch

PNP NC 01 -I ±....

PNP NO 03 -I ±....

Mechanical 05 -I ±....

Switch type
Pos. and direction
Switch activation point in mm

Direction
- 0 +
Reference edge

Switch
L/2

External switch

PNP NC 11 -A ±....

PNP NO 13 -A ±....

Mechanical 15 -A ±....

Switch type
Pos. and direction
Switch activation point in mm

External switching cam 16

External socket-plug (loose) 17

Cable duct (loose)

Cable duct 20 - X....

Type
Length in mm

02 Friction moment

03 Lead deviation

01

04 Sequence accuracy

05 Positioning accuracy

STAR – Aluminum Ball Rail® Tables

TKK 30-325 Al Dimension Drawings

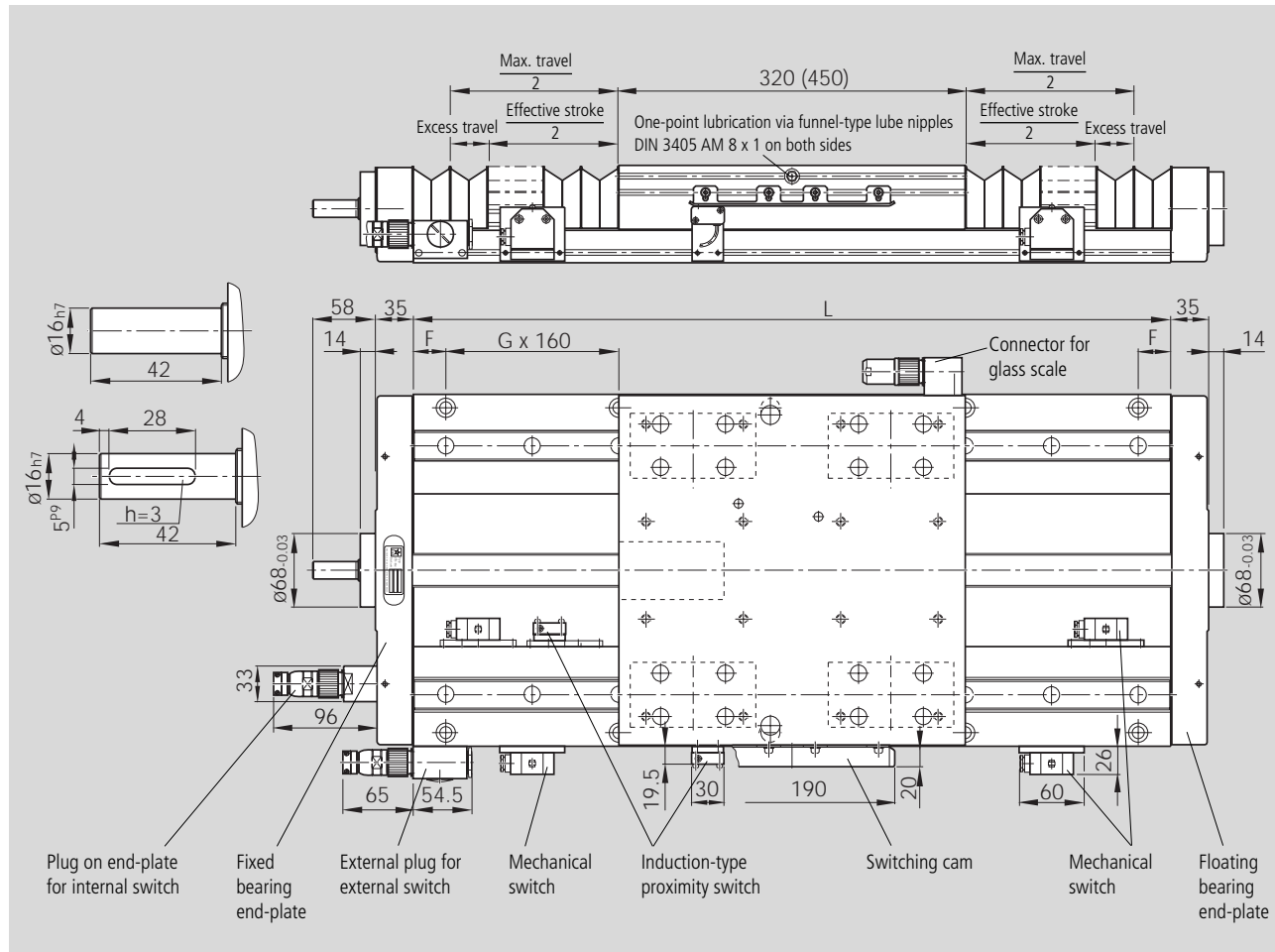

| Length L (mm) | Counterbored mounting hole spacing F - G x 120 - F | Max. travel for carriage length* | | | |
|------------------|---|-------------------------------------|------|-----------------|------|
| | | with bellows | | without bellows | |
| | | 320* | 450* | 320* | 450* |
| 460 | 70 - 2 x 160 - 70 | - | - | 130 | - |
| 540 | 30 - 3 x 160 - 30 | 154 | - | 210 | - |
| 620 | 70 - 3 x 160 - 70 | 225 | 109 | 290 | 160 |
| 700 | 30 - 4 x 160 - 30 | 297 | 180 | 370 | 240 |
| 780 | 70 - 4 x 160 - 70 | 368 | 251 | 450 | 320 |
| 860 | 30 - 5 x 160 - 30 | 439 | 322 | 530 | 400 |
| 940 | 70 - 5 x 160 - 70 | 510 | 394 | 610 | 480 |
| 1020 | 30 - 6 x 160 - 30 | 582 | 465 | 690 | 560 |
| 1100 | 70 - 6 x 160 - 70 | 653 | 536 | 770 | 640 |
| 1180 | 30 - 7 x 160 - 30 | 724 | 604 | 850 | 720 |
| 1260 | 70 - 7 x 160 - 70 | 795 | 679 | 930 | 800 |
| 1340 | 30 - 8 x 160 - 30 | 866 | 750 | 1010 | 880 |
| 1420 | 70 - 8 x 160 - 70 | 938 | 821 | 1090 | 960 |
| 1500 | 30 - 9 x 160 - 30 | 1009 | 892 | 1170 | 1040 |
| 1580 | 70 - 9 x 160 - 70 | 1080 | 963 | 1250 | 1120 |
| 1660 | 30 - 10 x 160 - 30 | 1151 | 1035 | 1330 | 1200 |

| Length L (mm) | Counterbored mounting hole spacing F - G x 120 - F | Max. travel for carriage length* | | | |
|------------------|---|-------------------------------------|------|-----------------|------|
| | | with bellows | | without bellows | |
| | | 320* | 450* | 320* | 450* |
| 1740 | 70 - 10 x 160 - 70 | 1223 | 1106 | 1410 | 1280 |
| 1820 | 30 - 11 x 160 - 30 | 1294 | 1177 | 1490 | 1360 |
| 1900 | 70 - 11 x 160 - 70 | 1365 | 1248 | 1570 | 1440 |
| 1980 | 30 - 12 x 160 - 30 | 1436 | 1320 | 1650 | 1520 |
| 2060 | 70 - 12 x 160 - 70 | 1507 | 1391 | 1730 | 1600 |
| 2140 | 30 - 13 x 160 - 30 | 1579 | 1462 | 1810 | 1680 |
| 2220 | 70 - 13 x 160 - 70 | 1650 | 1533 | 1890 | 1760 |
| 2300 | 30 - 14 x 160 - 30 | 1721 | 1605 | 1970 | 1840 |
| 2380 | 70 - 14 x 160 - 70 | 1792 | 1676 | 2050 | 1920 |
| 2460 | 30 - 15 x 160 - 30 | 1864 | 1747 | 2130 | 2000 |
| 2540 | 70 - 15 x 160 - 70 | 1935 | 1818 | 2210 | 2080 |
| 2620 | 30 - 16 x 160 - 30 | 2006 | 1889 | 2290 | 2160 |
| 2700 | 70 - 16 x 160 - 70 | 2077 | 1961 | 2370 | 2240 |
| 2780 | 30 - 17 x 160 - 30 | 2148 | 2032 | 2450 | 2320 |
| 2860 | 70 - 17 x 160 - 70 | 2220 | 2103 | 2530 | 2400 |



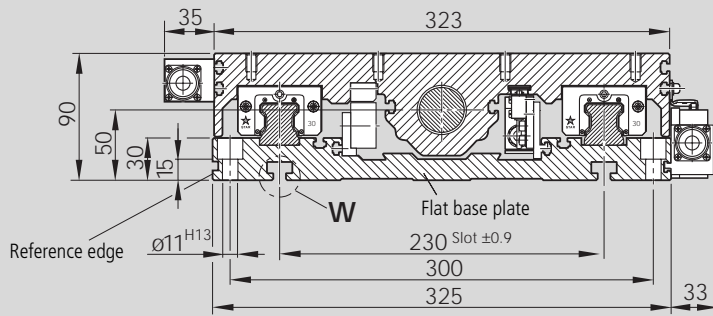

Mounting hole pattern for carriage length $L_T = 320$

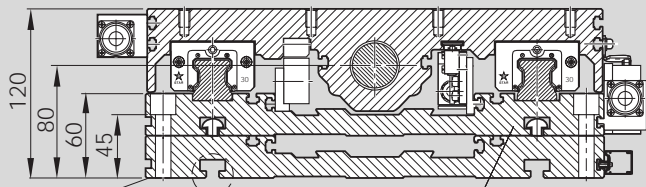
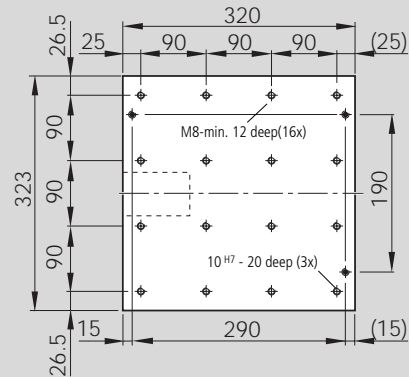

Mounting hole pattern for carriage length $L_T = 450$

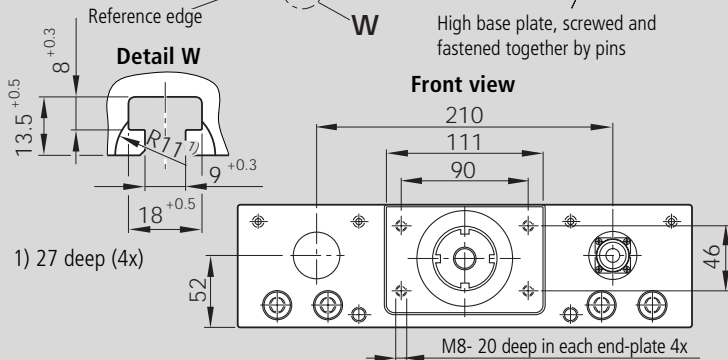
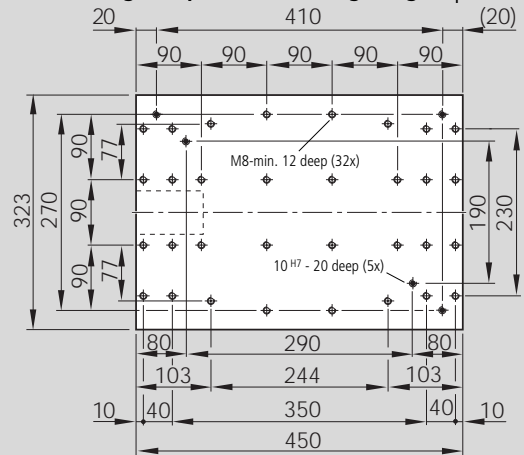

Effective stroke

For safe operation, the excess travel must be longer than the braking distance. The acceleration travel can be taken as guideline value for the braking distance. In most cases, 2x the ball screw lead (P) will be sufficient.

Example for $P = 32$ mm:
Excess travel (braking distance) ≈ 64 mm

Recommended standard configuration:
– 2 mechanical switches
– 1 proximity switch

$$\text{Effective stroke} = \text{max. travel} - 2 \cdot \text{excess travel}$$

Distance between switch activation points of two switches

| Switch position | For switch combination | Min. spacing (mm) |
|-----------------|-------------------------|-------------------|
| external | mechanical - mechanical | 60 |
| | mechanical - proximity | 45 |
| | proximity - proximity | 12.5 |
| internal | mechanical - mechanical | 70 |
| | mechanical - proximity | 50 |
| | proximity - proximity | 25 |

Maximum switch activation point

The switch activation point characterizes the position of the center of the carriage after travel. The zero point is at $L/2$.

$$\text{Maximum switch activation point} = 0.5 \cdot \text{max. travel} - \text{excess travel}$$

STAR – Steel Ball Rail Tables

TKK 30-325 St Options Table

| Part number 1460-400-00, mm See dimensions table for length | | Type | Guide-way = .. | Drive unit = .. | Carriage = .. | | | | | | | |
|--|--|--|----------------|-------------------------------|------------------|---------|---------|---------|--------------------------------|-------------------------|----|----|
| <p>Internal switch External switch Reference edge Switch side</p> | | Dimension drawing no. for motor attachment | | | | | | | | | | |
| | | | Base plate | Ball screw journal | Ball screw drive | | | | Carriage length L _T | | | |
| | | | flat | keyway | 32 x 5 | 32 x 10 | 32 x 20 | 32 x 32 | 320 mm Preload 2% 8% | 450 mm Preload 2% 8% | | |
| without drive unit (without end-plates) | | | | | | | | | | | | |
| OA01 | | | 01 | | | 00 | | | 05 | 06 | 07 | 08 |
| without motor mount and motor | | | | | | | | | | | | |
| OF01 | | | 01 | dia 16 (fixed bearing end) | 07 | 13 | 19 | 25 | 05 | 06 | 07 | 08 |
| OF04 | | | | dia 16 keyway (fixed brg.) | 10 | 16 | 22 | 28 | | | | |
| with motor mount and coupling, with or without motor | | | | | | | | | | | | |
| MF01 | | | 01 | dia 16 (fixed bearing end) | 07 | 13 | 19 | 25 | 05 | 06 | 07 | 08 |
| MF02 | | 14.46.20 | | | | | | | | | | |
| with side drive with timing belt, with or without motor | | | | | | | | | | | | |
| RV01 | | | 01 | dia 19 (floating bearing end) | 09 | 15 | 21 | 27 | 05 | 06 | 07 | 08 |
| RV02 | | | | | | | | | | | | |
| RV03 | | 14.46.90 | | | | | | | | | | |
| RV04 | | | | | | | | | | | | |
| RV05 | | 14.46.70 | | | | | | | | | | |
| RV06 | | | | | | | | | | | | |

Please check whether the selected combination is a permissible one (load capacities, moments, maximum speeds, motor data, etc.)!

| Motor attachment = .. | | Motor = .. | Cover = .. | Position measuring system = .. | 1st switch = .. ± mm 2nd switch = .. ± mm 3rd switch = .. ± mm Cable duct = .. - mm Socket-plug = .. Switching cam = .. | | | | | Documentation = .. | | |
|-----------------------|----------------|-----------------------------------|------------------|--------------------------------|--|---------------------|------------------|-----------------|----------------|--------------------|--|--|
| i = | | Mounting direction as per diagram | Motor type | Polyurethane bellows without | Polyurethane bellows with | Glass scale without | Glass scale with | Standard report | Special report | | | |
| | | OA01 (00) | without (00) | (00) | on request | | | | | | | |
| | | OF01-OF04 (00) | without (00) | | | | | | | | | |
| 1 | MF01-MF02 (06) | | without (00) | | | | | | | | | |
| | | | MKD 71B-061 (11) | | | | | | | | | |
| | | | MHD 71B-061 (62) | (00) | (01) | (00) | on request | | | | | |
| 1 | RV01-RV04 (69) | | without (00) | | | | | | | | | |
| | | RV05-RV06 (70) | | | | | | | | | | |
| 2 | RV01-RV04 (71) | | MHD 71B-061 (62) | | | | | | | | | |
| | | RV05-RV06 (72) | | | | | | | | | | |
| 1 | RV01-RV04 (73) | | without (00) | | | | | | | | | |
| | | RV05-RV06 (74) | | | | | | | | | | |
| | | | MKD 71B-061 (11) | | | | | | | | | |
| 2 | RV01-RV04 (75) | | MHD 71B-061 (62) | | | | | | | | | |
| | | RV05-RV06 (76) | | | | | | | | | | |

| | | | |
|--|---|---|---------------------------|
| without switch without cable duct (00) | Internal switch | Socket-plug on end-plate Switching cam (07) | Friction moment (02) |
| PNP NC (01 -) ± | PNP NO (03 -) ± | Mechanical (05 -) ± | |
| Switch type | Pos. and direction | Switch activation point in mm | Lead deviation (03) |
| Direction - 0 + | Reference edge | Switch L/2 | |
| External switch | External switching cam with profiled support (26) | External socket-plug (loose) (17) | Sequence accuracy (04) |
| PNP NC (11 -A) ± | PNP NO (13 -A) ± | Mechanical (15 -A) ± | |
| Switch type | Pos. and direction | Switch activation point in mm | Positioning accuracy (05) |
| Cable duct (loose) | Cable duct (20 - X....) | Type | |
| | | Length in mm | |

STAR – Steel Ball Rail Tables

TKK 30-325 St Dimension Drawings

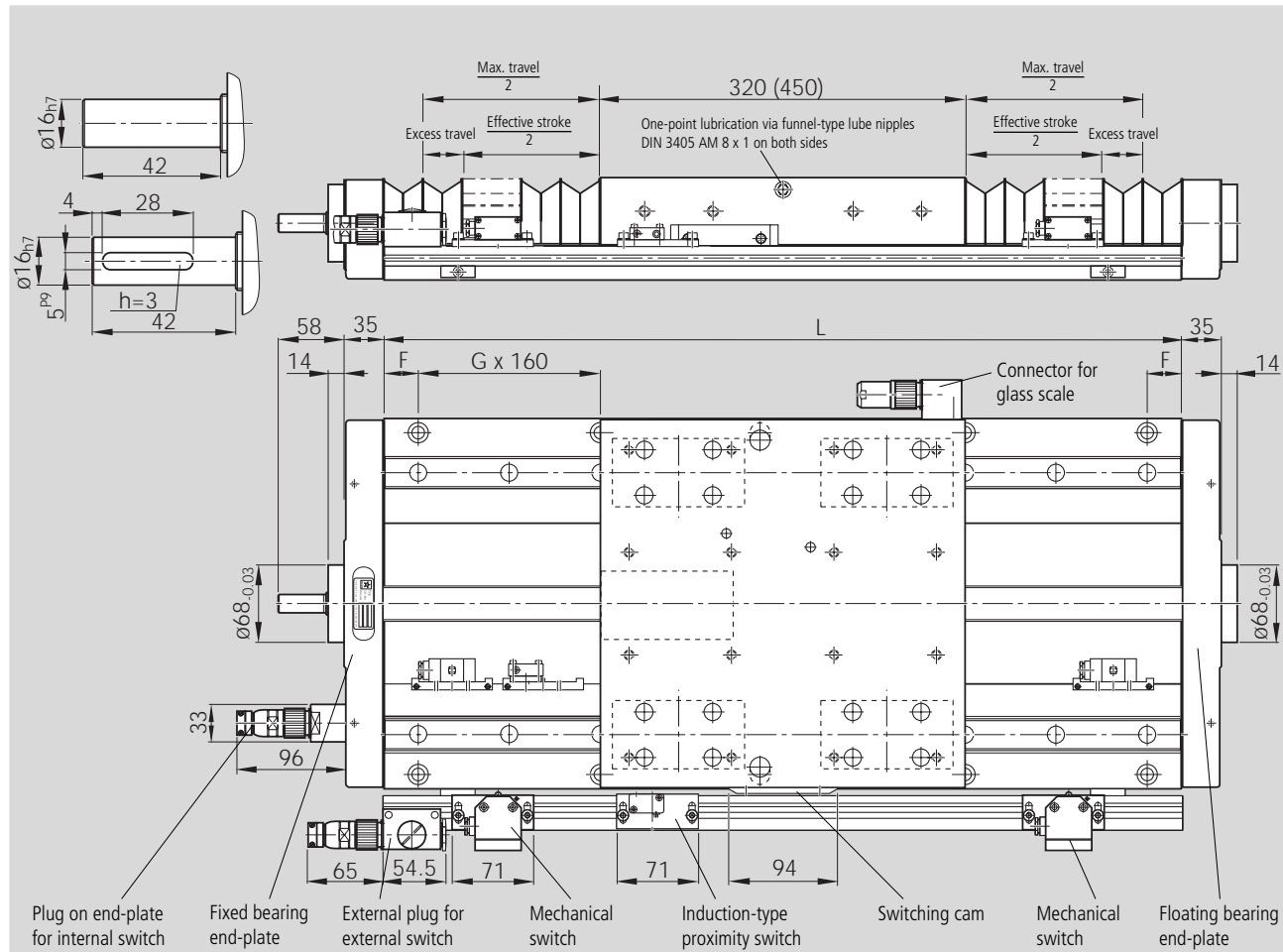

| Length L (mm) | Counterbored mounting hole spacing F - G x 120 - F | Max. travel for carriage length* | | | |
|------------------|---|-------------------------------------|------|-----------------|------|
| | | with bellows | | without bellows | |
| | | 320* | 450* | 320* | 450* |
| 460 | 70 - 2 x 160 - 70 | - | - | 130 | - |
| 540 | 30 - 3 x 160 - 30 | 154 | - | 210 | - |
| 620 | 70 - 3 x 160 - 70 | 225 | 109 | 290 | 160 |
| 700 | 30 - 4 x 160 - 30 | 297 | 180 | 370 | 240 |
| 780 | 70 - 4 x 160 - 70 | 368 | 251 | 450 | 320 |
| 860 | 30 - 5 x 160 - 30 | 439 | 322 | 530 | 400 |
| 940 | 70 - 5 x 160 - 70 | 510 | 394 | 610 | 480 |
| 1020 | 30 - 6 x 160 - 30 | 582 | 465 | 690 | 560 |
| 1100 | 70 - 6 x 160 - 70 | 653 | 536 | 770 | 640 |
| 1180 | 30 - 7 x 160 - 30 | 724 | 604 | 850 | 720 |
| 1260 | 70 - 7 x 160 - 70 | 795 | 679 | 930 | 800 |
| 1340 | 30 - 8 x 160 - 30 | 866 | 750 | 1010 | 880 |
| 1420 | 70 - 8 x 160 - 70 | 938 | 821 | 1090 | 960 |
| 1500 | 30 - 9 x 160 - 30 | 1009 | 892 | 1170 | 1040 |
| 1580 | 70 - 9 x 160 - 70 | 1080 | 963 | 1250 | 1120 |
| 1660 | 30 - 10 x 160 - 30 | 1151 | 1035 | 1330 | 1200 |

| Length L (mm) | Counterbored mounting hole spacing F - G x 120 - F | Max. travel for carriage length* | | | |
|------------------|---|-------------------------------------|------|-----------------|------|
| | | with bellows | | without bellows | |
| | | 320* | 450* | 320* | 450* |
| 1740 | 70 - 10 x 160 - 70 | 1223 | 1106 | 1410 | 1280 |
| 1820 | 30 - 11 x 160 - 30 | 1294 | 1177 | 1490 | 1360 |
| 1900 | 70 - 11 x 160 - 70 | 1365 | 1248 | 1570 | 1440 |
| 1980 | 30 - 12 x 160 - 30 | 1436 | 1320 | 1650 | 1520 |
| 2060 | 70 - 12 x 160 - 70 | 1507 | 1391 | 1730 | 1600 |
| 2140 | 30 - 13 x 160 - 30 | 1579 | 1462 | 1810 | 1680 |
| 2220 | 70 - 13 x 160 - 70 | 1650 | 1533 | 1890 | 1760 |
| 2300 | 30 - 14 x 160 - 30 | 1721 | 1605 | 1970 | 1840 |
| 2380 | 70 - 14 x 160 - 70 | 1792 | 1676 | 2050 | 1920 |

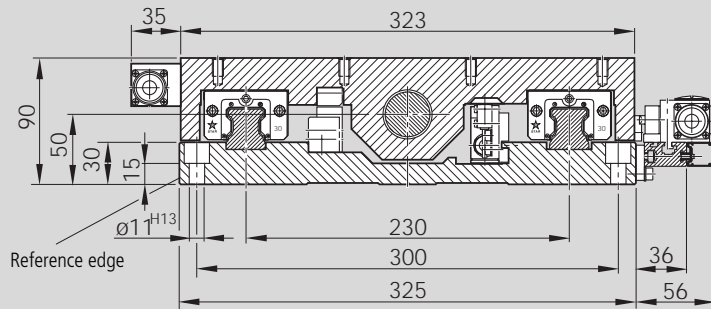

Mounting hole pattern for carriage length $L_T = 320$

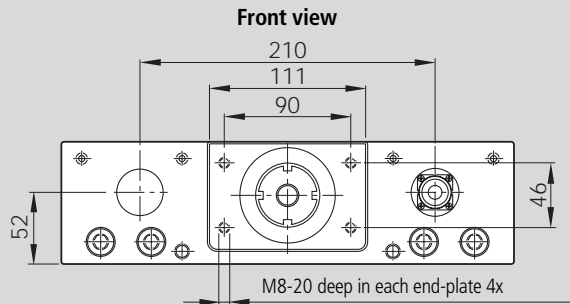
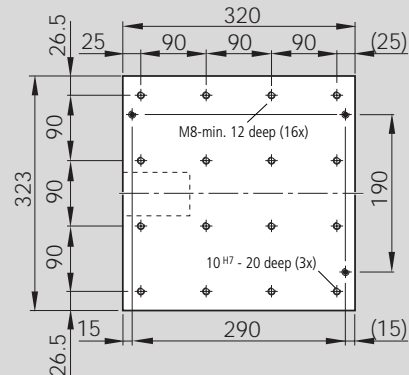

Mounting hole pattern for carriage length $L_T = 450$

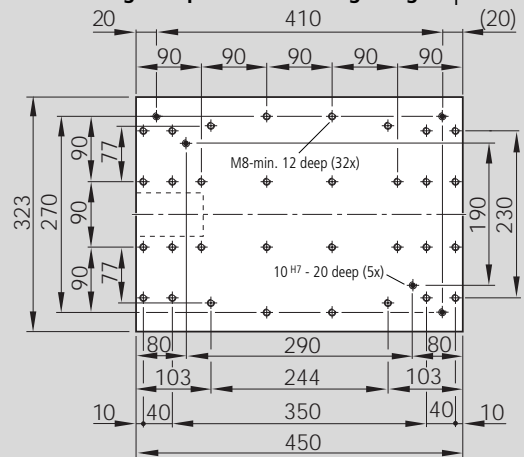

Effective stroke

For safe operation, the excess travel must be longer than the braking distance. The acceleration travel can be taken as guideline value for the braking distance. In most cases, 2x the ball screw lead (P) will be sufficient.

Example for $P = 32$ mm:
Excess travel (braking distance) ≈ 64 mm

Recommended standard configuration:
– 2 mechanical switches
– 1 proximity switch

$$\text{Effective stroke} = \text{max. travel} - 2 \cdot \text{excess travel}$$

Distance between switch activation points of two switches

| Switch position | For switch combination | Min. spacing (mm) |
|-----------------|-------------------------|-------------------|
| external | mechanical - mechanical | 62 |
| | mechanical - proximity | 49 |
| | proximity - proximity | 35 |
| internal | mechanical - mechanical | 70 |
| | mechanical - proximity | 50 |
| | proximity - proximity | 25 |

Maximum switch activation point

The switch activation point characterizes the position of the center of the carriage after travel. The zero point is at $L/2$.

$$\text{Maximum switch activation point} = 0.5 \cdot \text{max. travel} - \text{excess travel}$$

STAR – Ball Rail Tables

TKK 30-325 Dimension Drawings, Motor Attachment

Motor attachment with motor mount and coupling

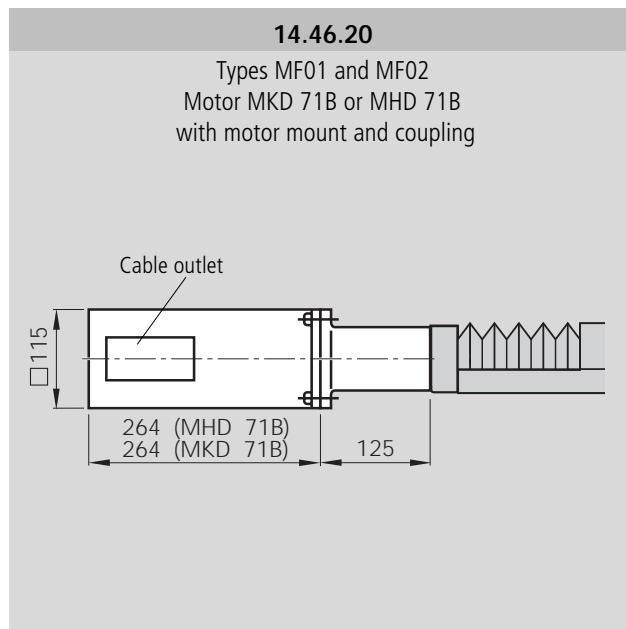

Motor attachment for side drive with timing belt

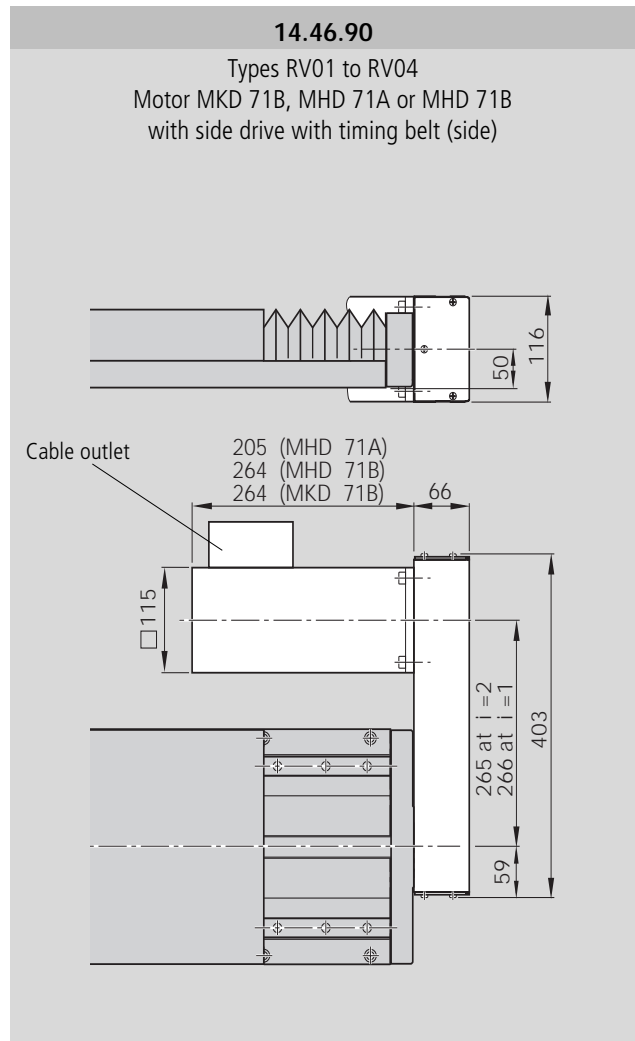
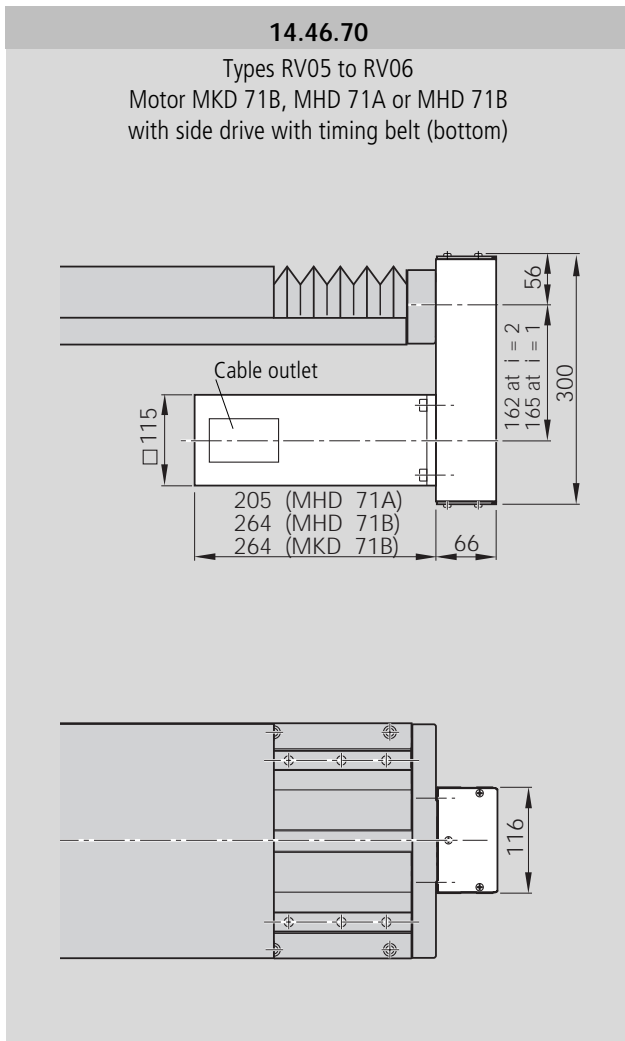

Note for steel version

In version RV01 and RV02 with externally mounted switches:
no switches may be mounted in the motor area!

Note for multi-axis units (e.g. cross-tables)

For multi-axis units with motor attachment via side drive with
timing belt, the motor may project into the working area of
adjacent axes. Check for any interference contours!

For motor dimensions see "Motors"

STAR – Aluminum Ball Rail® Tables

TKK 35-455 Al Options Table

| Part number 1460-505-00, mm See dimensions table for length | | Type | Guide-way = .. | Drive unit = .. | | | | Carriage = .. | |
|--|--|--|-------------------|-------------------------------|------------------|---------|--------------------------------|---------------|-------------------------|
| | | Dimension drawing no. for motor attachment | | | | | | | |
| | | | Base plate | Ball screw journal keyway | Ball screw drive | | Carriage length L _T | | |
| | | | flat | | 40 x 5 | 40 x 10 | 40 x 20 | 40 x 40 | 450 mm Preload 2% 8% |
| without drive unit (without end-plates) | | | | | | | | | |
| OA01 | | | 01 | | | 00 | | 05 06 | |
| without motor mount and motor | | | | | | | | | |
| OF01 | | OF04 | 01 | dia 25 (fixed bearing end) | 25 | 31 | 37 | 43 | 05 06 |
| | | | | dia 25 keyway (fixed brg.) | 28 | 34 | 40 | 46 | |
| with motor mount and coupling, with or without motor | | | | | | | | | |
| MF01 | | | 01 | dia 25 (fixed bearing end) | 25 | 31 | 37 | 43 | 05 06 |
| MF02 | | | | | | | | | |
| with side drive with timing belt, with or without motor | | | | | | | | | |
| RV01 | | RV02 | | | | | | | |
| | | | | | | | | | |
| RV03 | | RV04 | 01 | dia 24 (floating bearing end) | 27 | 33 | 39 | 45 | 05 06 |
| | | | | | | | | | |
| RV05 | | RV06 | | | | | | | |
| | | | | | | | | | |

Please check whether the selected combination is a permissible one (load capacities, moments, maximum speeds, motor data, etc.)!

| Motor attachment = .. | | Motor = .. | Cover = .. | Position measuring system = .. | 1st switch = .. ± mm 2nd switch = .. ± mm 3rd switch = .. ± mm Cable duct = .. - mm Socket-plug = .. Switching cam = .. | | | | Documentation = .. | |
|-----------------------------------|-----------|------------|----------------------|--------------------------------|--|------------|------|------|---------------------------|----------------|
| i = | | Motor type | Polyurethane bellows | Glass scale | | | | | Standard report | Special report |
| Mounting direction as per diagram | | without | with | without | with | without | with | | | |
| | OA01 | (00) | without | (00) | (00) | on request | | | (02) Friction moment | |
| | OF01-OF04 | (00) | without | (00) | | | | | (03) Lead deviation | |
| 1 | MF01-MF02 | (08) | without | (00) | MKD 90B-047 | (13) | | | | |
| | | | | | MKD 90B-047 | (63) | (00) | (01) | (00) on request | |
| 1 | RV01-RV04 | (49) | without | (00) | | | | | | |
| | RV05-RV06 | (50) | | | MKD 71B-061 | (11) | | | (04) Sequence accuracy | |
| 2 | RV01-RV04 | (51) | | | MHD 71B-061 | (62) | | | | |
| | RV05-RV06 | (52) | | | | | | | | |
| 1 | RV01-RV04 | (53) | without | (00) | | | | | | |
| | RV05-RV06 | (54) | | | MKD 90B-047 | (13) | | | (05) Positioning accuracy | |
| 2 | RV01-RV04 | (55) | | | MHD 90B-047 | (63) | | | | |
| | RV05-RV06 | (56) | | | | | | | | |

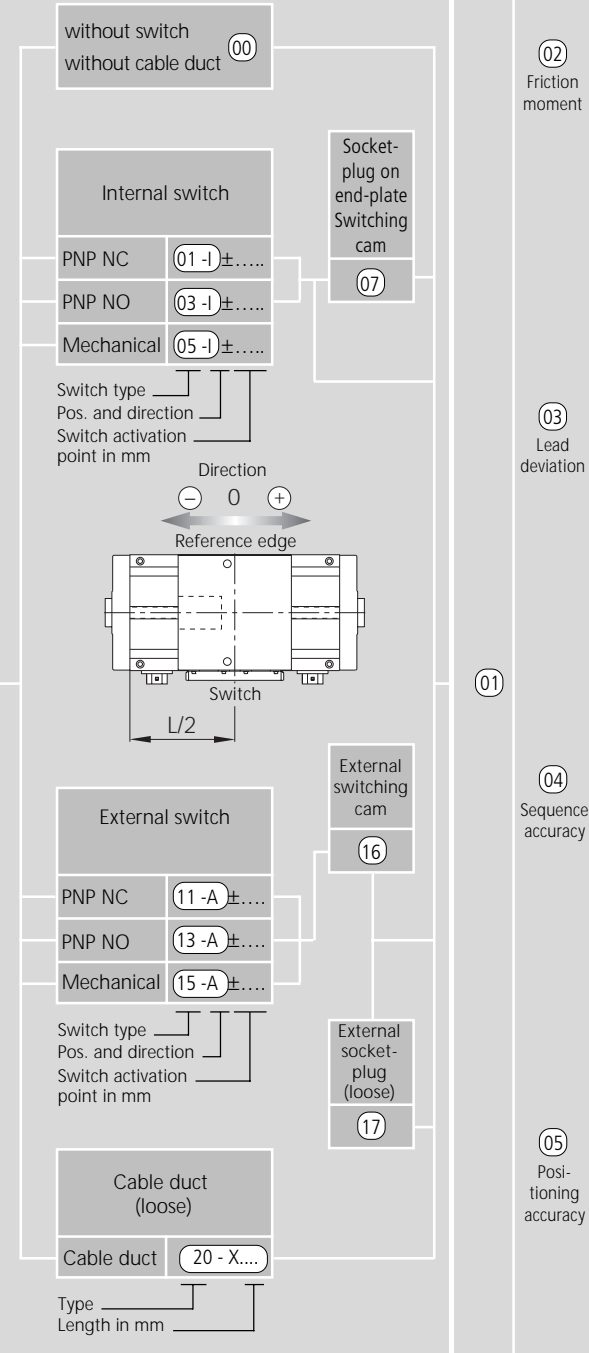

STAR – Aluminum Ball Rail® Tables

TKK 35-455 Al Dimension Drawings

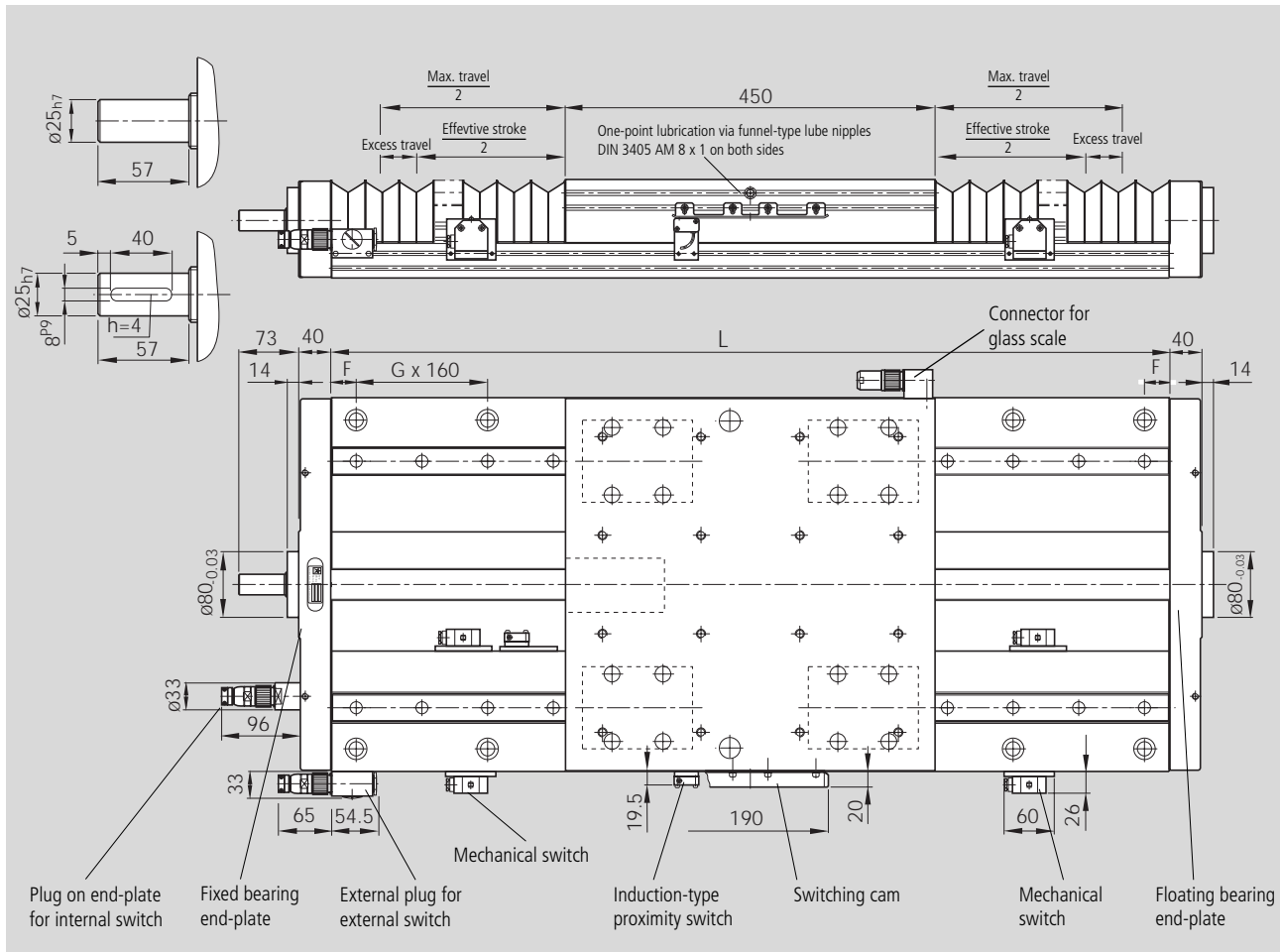

| Length L (mm) | Counterbored mounting hole spacing F - G x 120 - F | Max. travel for carriage length* | |
|------------------|---|-------------------------------------|-------------------------|
| | | with bellows 450* | without bellows 450* |
| 620 | 70 - 3 x 160 - 70 | 110 | 160 |
| 700 | 30 - 4 x 160 - 30 | 183 | 240 |
| 780 | 70 - 4 x 160 - 70 | 256 | 320 |
| 860 | 30 - 5 x 160 - 30 | 328 | 400 |
| 940 | 70 - 5 x 160 - 70 | 401 | 480 |
| 1020 | 30 - 6 x 160 - 30 | 474 | 560 |
| 1100 | 70 - 6 x 160 - 70 | 546 | 640 |
| 1180 | 30 - 7 x 160 - 30 | 619 | 720 |
| 1260 | 70 - 7 x 160 - 70 | 692 | 800 |
| 1340 | 30 - 8 x 160 - 30 | 746 | 880 |
| 1420 | 70 - 8 x 160 - 70 | 837 | 960 |
| 1500 | 30 - 9 x 160 - 30 | 910 | 1040 |
| 1580 | 70 - 9 x 160 - 70 | 982 | 1120 |
| 1660 | 30 - 10 x 160 - 30 | 1055 | 1200 |
| 1740 | 70 - 10 x 160 - 70 | 1127 | 1200 |

| Length L (mm) | Counterbored mounting hole spacing F - G x 120 - F | Max. travel for carriage length* | |
|------------------|---|-------------------------------------|-------------------------|
| | | with bellows 450* | without bellows 450* |
| 1820 | 30 - 11 x 160 - 30 | 1200 | 1360 |
| 1900 | 70 - 11 x 160 - 70 | 1273 | 1440 |
| 1980 | 30 - 12 x 160 - 30 | 1345 | 1520 |
| 2060 | 70 - 12 x 160 - 70 | 1418 | 1600 |
| 2140 | 30 - 13 x 160 - 30 | 1491 | 1680 |
| 2220 | 70 - 13 x 160 - 70 | 1563 | 1760 |
| 2300 | 30 - 14 x 160 - 30 | 1636 | 1840 |
| 2380 | 70 - 14 x 160 - 70 | 1709 | 1920 |
| 2460 | 30 - 15 x 160 - 30 | 1781 | 2000 |
| 2540 | 70 - 15 x 160 - 70 | 1854 | 2080 |
| 2620 | 30 - 16 x 160 - 30 | 1927 | 2160 |
| 2700 | 70 - 16 x 160 - 70 | 1999 | 2240 |
| 2780 | 30 - 17 x 160 - 30 | 2072 | 2320 |
| 2860 | 70 - 17 x 160 - 70 | 2144 | 2400 |

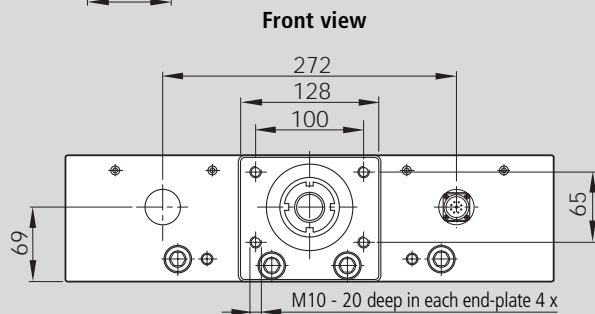
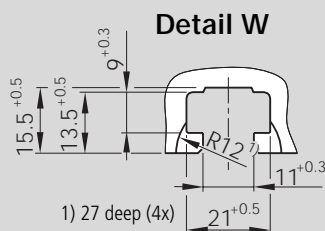
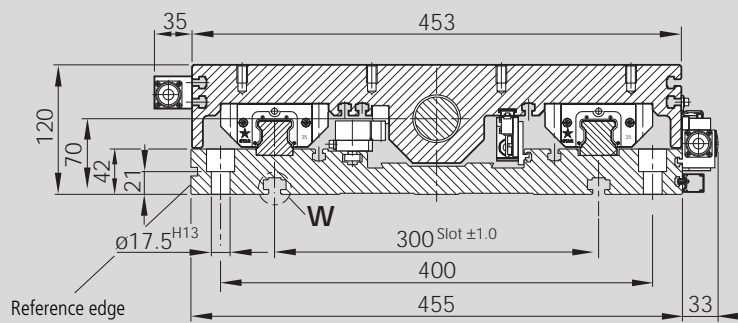

Mounting hole pattern for carriage

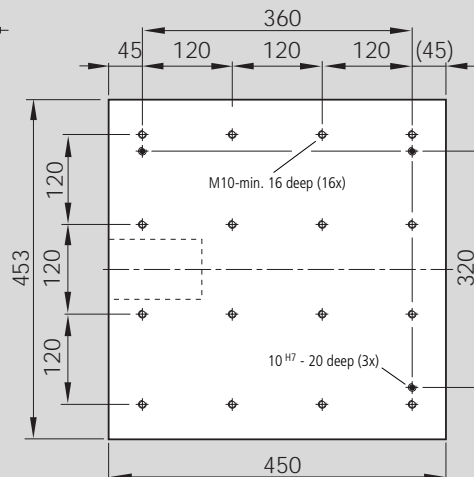

Effective stroke

For safe operation, the excess travel must be longer than the braking distance. The acceleration travel can be taken as guideline value for the braking distance. In most cases, 2x the ball screw lead (P) will be sufficient.

Example for P = 40 mm:

Excess travel (braking distance) ≈ 80 mm

Recommended standard configuration:

- 2 mechanical switches
- 1 proximity switch

$$\text{Effective stroke} = \text{max. travel} - 2 \cdot \text{excess travel}$$

Distance between switch activation points of two switches

| Switch position | For switch combination | Min. spacing (mm) |
|-----------------|-------------------------|-------------------|
| external | mechanical - mechanical | 60 |
| | mechanical - proximity | 45 |
| | proximity - proximity | 12.5 |
| internal | mechanical - mechanical | 70 |
| | mechanical - proximity | 50 |
| | proximity - proximity | 25 |

Maximum switch activation point

The switch activation point characterizes the position of the center of the carriage after travel. The zero point is at L/2.

$$\text{Maximum switch activation point} = 0.5 \cdot \text{max. travel} - \text{excess travel}$$

STAR – Aluminum Ball Rail® Tables

TKK 35-455 Al Dimension Drawings, Motor Attachment

Motor attachment with motor mount and coupling

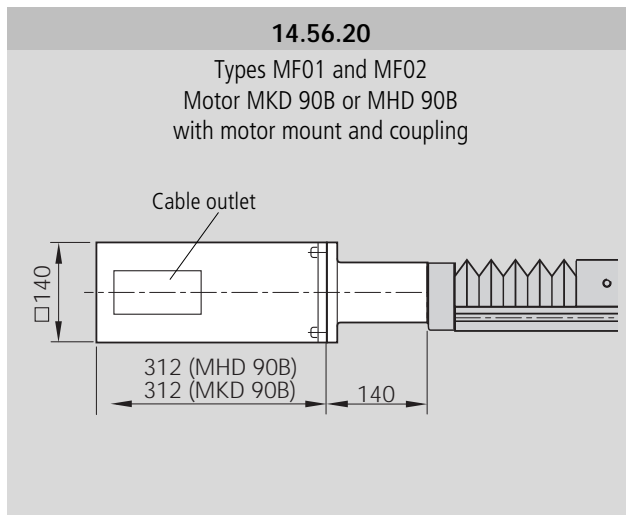

Motor attachment for side drive with timing belt

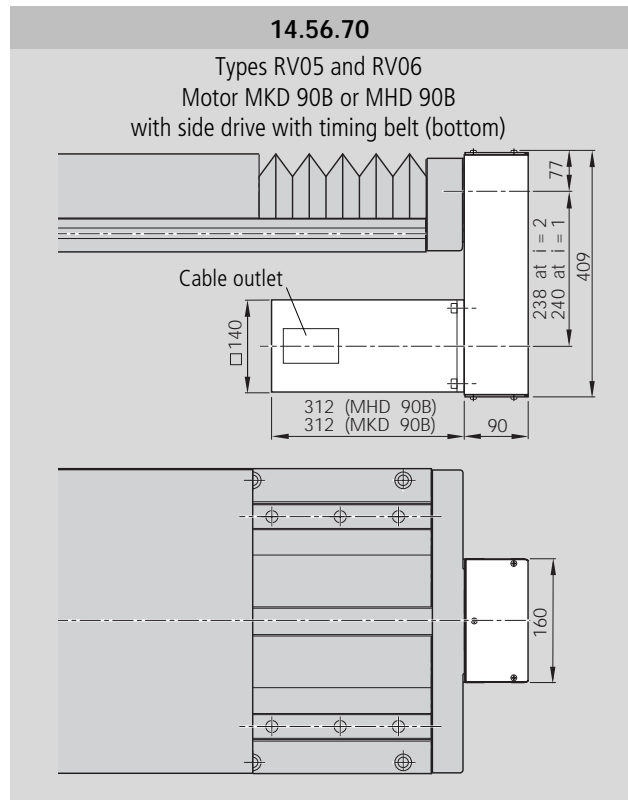
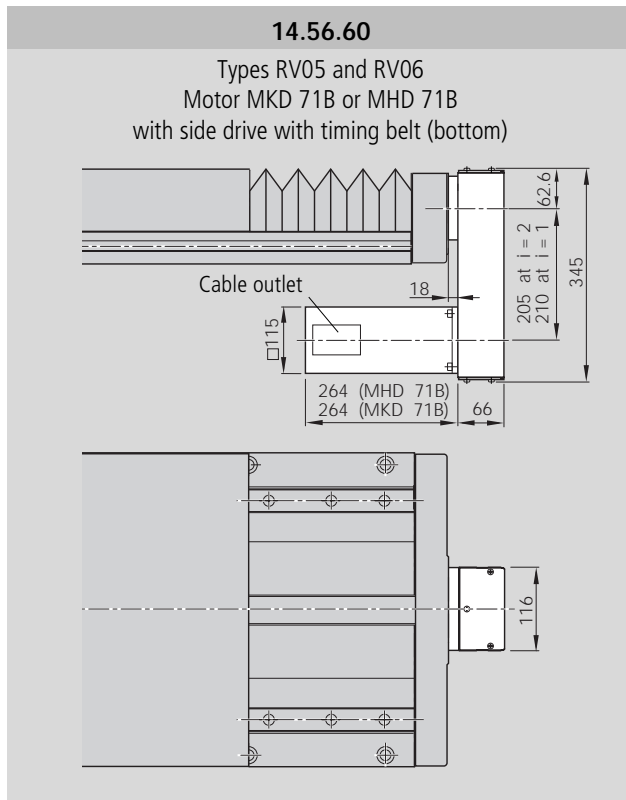

Motor attachment for side drive with timing belt

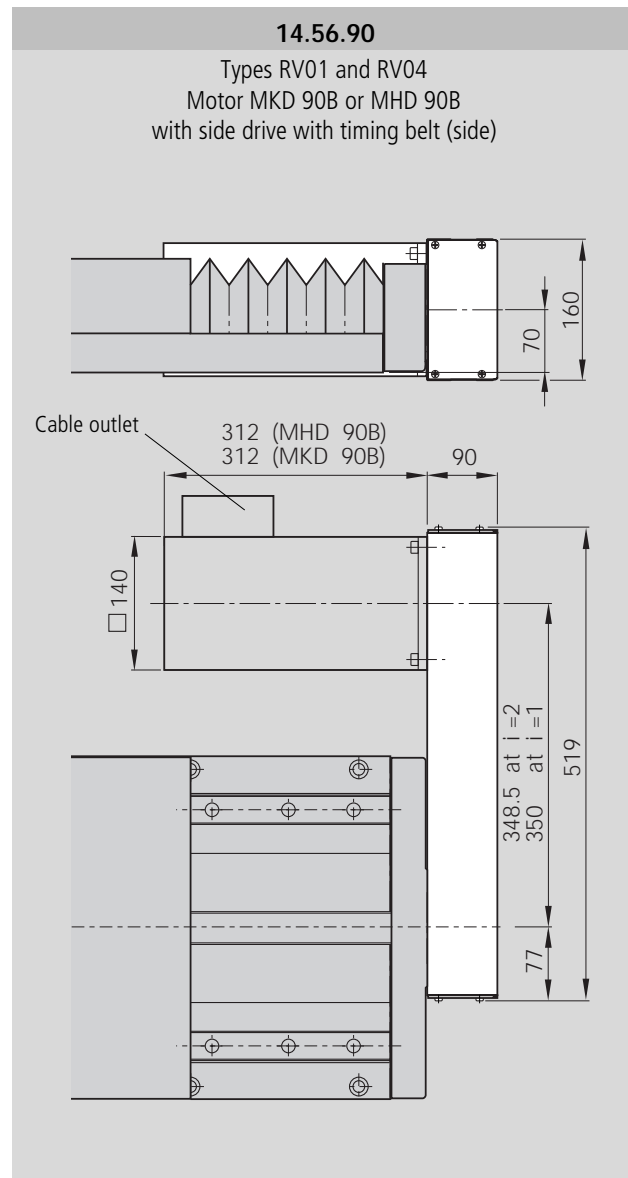
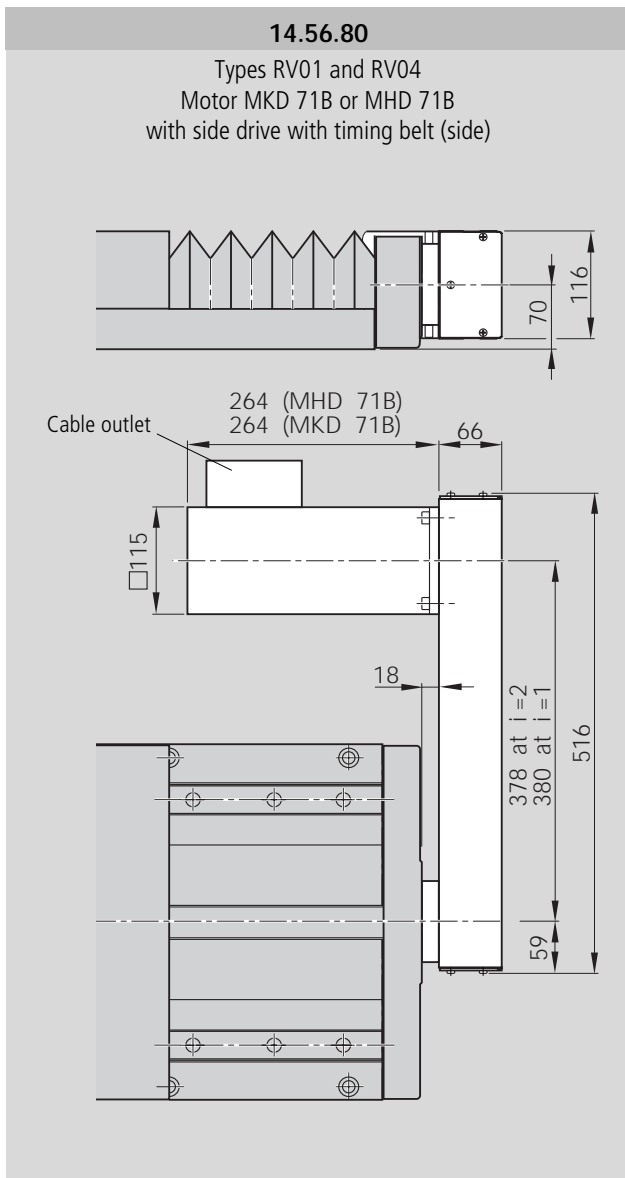

For motor dimensions see "Motors"

Note for multi-axis units (e.g. cross-tables)

For multi-axis units with motor attachment via side drive with timing belt, the motor may project into the working area of adjacent axes. Check for any interference contours!

STAR – Ball Rail Tables

Switch Mounting Arrangements

Overview of the switching system

Accessories:

- 1 Mechanical switch, external
- 2 Switching cam
- 3 Proximity switch, external
- 4 Socket/plug for external switches
- 5 Mechanical and proximity switches, internal
- 6 Socket/plug for internal switches
- 7 Profiled support

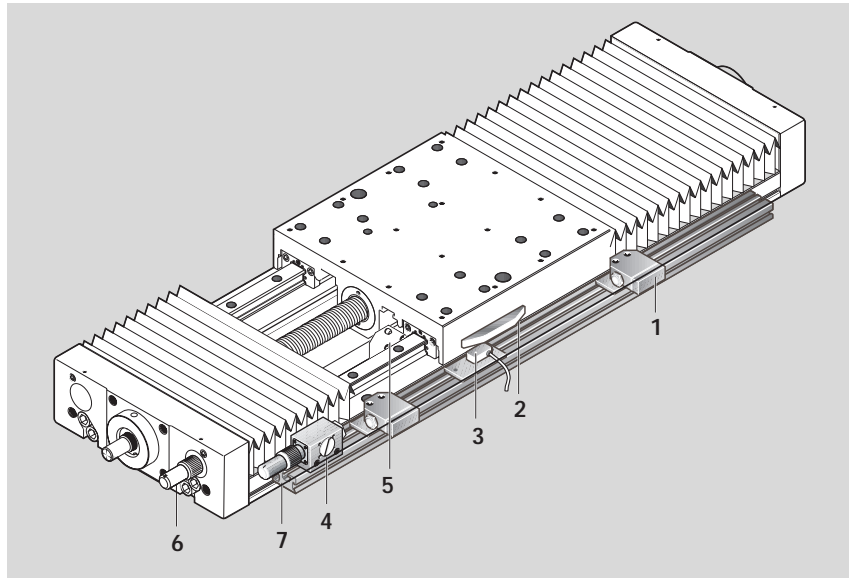

Internal mechanical switch

| | |
|---------------------------------------|---------------------------|
| Reproducibility | = ± 0.05 mm |
| Permissible ambient temperature | = -5°C to +80°C |
| Enclosure | = DIN 40050 IP 67 |
| Contact time | = < 2 ms |
| Insulation | = group C to VDE 0110 |
| Rated voltage | = 250 V AC |
| Continuous current | = 5 A |
| Switching capacity at 220 V, 40-60 Hz | = $\cos\phi = 0.8$ at 2 A |
| Contact resistance when new | = < 240 mΩ |
| Connection | = screw connection |
| Contact system | = single-pole changeover |
| Switch system | = snap-action |

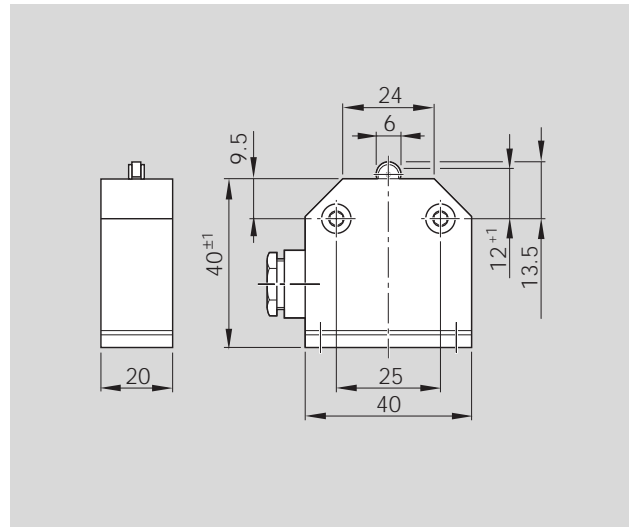

External mechanical switch

| | |
|---------------------------------------|---------------------------|
| Reproducibility | = ± 0.05 mm |
| Permissible ambient temperature | = -5°C to +80°C |
| Enclosure | = DIN 40050 IP 67 |
| Contact time | = < 2 ms |
| Insulation | = group C to VDE 0110 |
| Rated voltage | = 250 V AC |
| Continuous current | = 5 A |
| Switching capacity at 220 V, 40-60 Hz | = $\cos\phi = 0.8$ at 2 A |
| Contact resistance when new | = < 240 mΩ |
| Connection | = screw connection |
| Contact system | = single-pole changeover |
| Switch system | = snap-action |

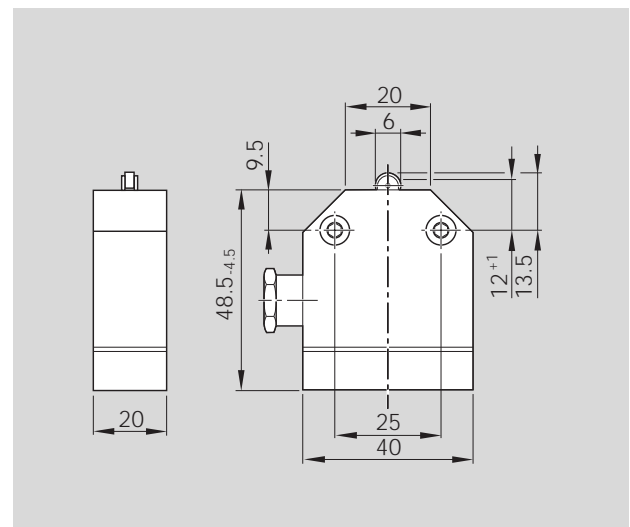

Induction-type proximity switch internal and external

Miniature circuit-breakers with potted cable (3 x 0.14 mm² Unitronic),

| | | |
|--|---|------------------|
| Housing form | = | NO |
| Minisensor | = | Form A DIN 41635 |
| Voltage | = | 10 to 30 V DC |
| Residual ripple | = | ≤ 10 % |
| Load | = | 200 mA |
| No-load current | = | ≤ 20 mA |
| Switching frequency | = | max. 1500 Hz |
| Temperature-related shift in make point | = | ≤ 4 μm/°C |
| Output signal steepness | = | ≥ 1V/μs |
| Repeatability of make point to EN 50008 | = | ≤ 0.1 mm |

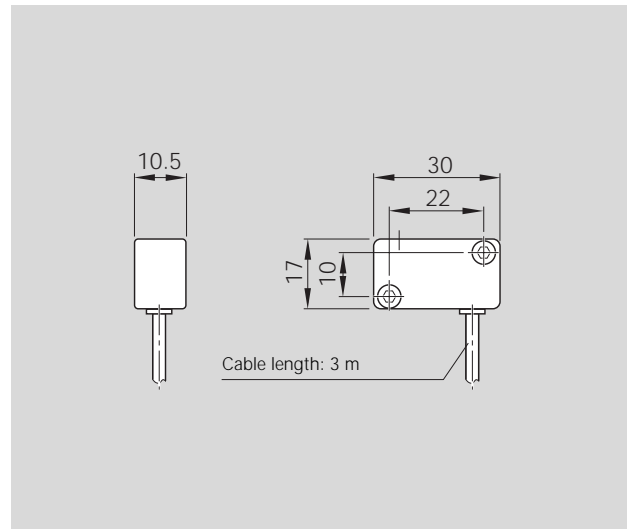

End-plate-mounted socket and plug for internal switches

- Socket and plug each have 16 pins.
- Socket and switch are prewired.
- A plug is provided.

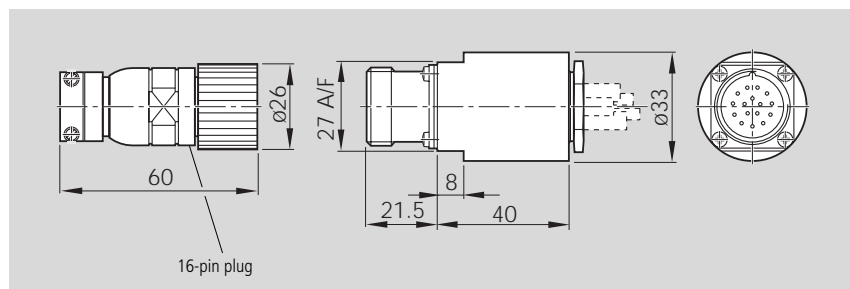

Externally mounted socket and plug for external switches

- Socket and plug each have 16 pins.
- Socket and switch are not prewired. The switch activation points can thus be optimized during start-up.
- A plug is provided.

The plug can be mounted in three directions (see diagram).

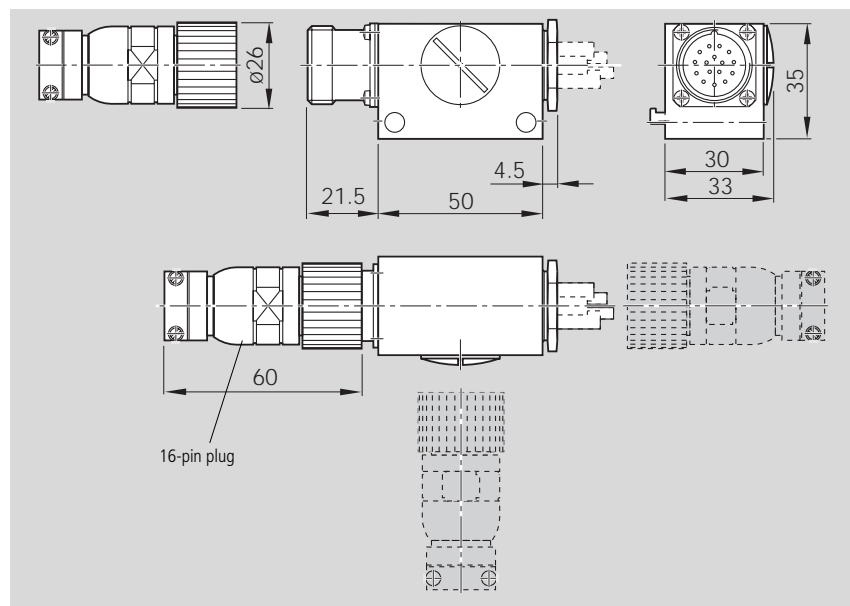

Cable duct

- The cable duct holds a maximum of two cables for mechanical switches and three cables for proximity switches.
- The duct is fixed by clipping to the T-slot on the table and is secured by tightening the fixing screws.
- The fixing screws and cable grommets are supplied with the duct.

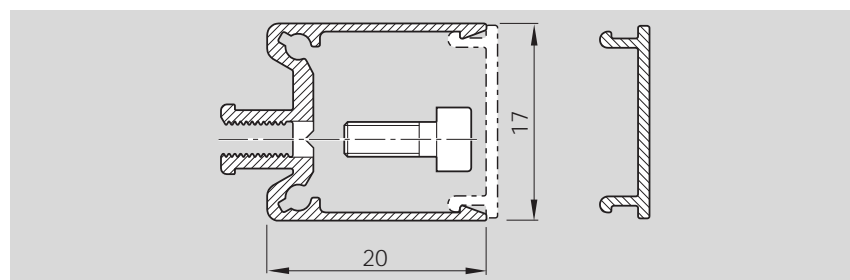

STAR – Ball Rail Tables Motors

Dimensions of AC Servomotors

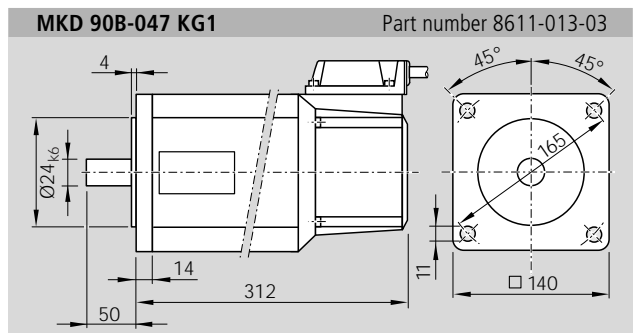
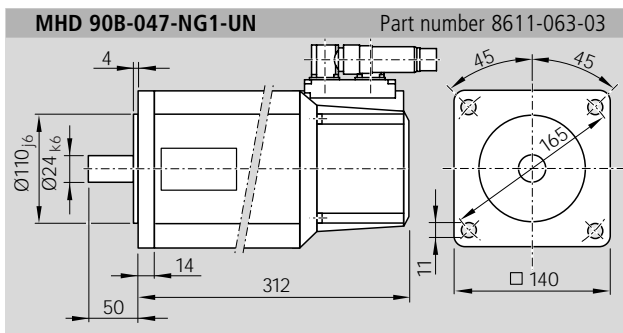
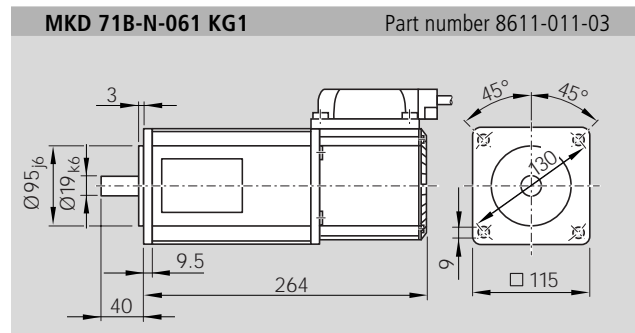
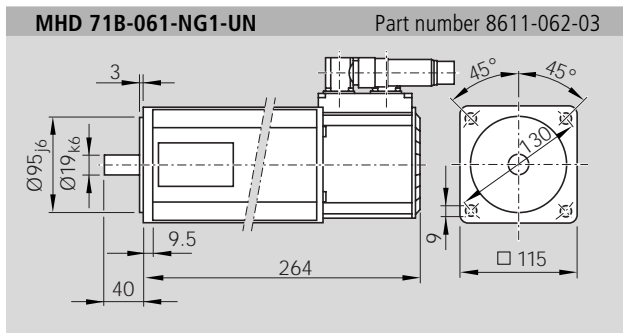
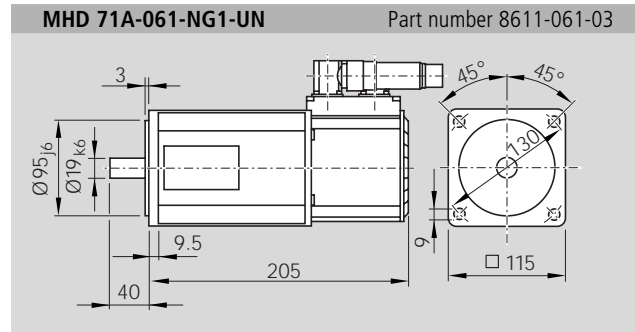
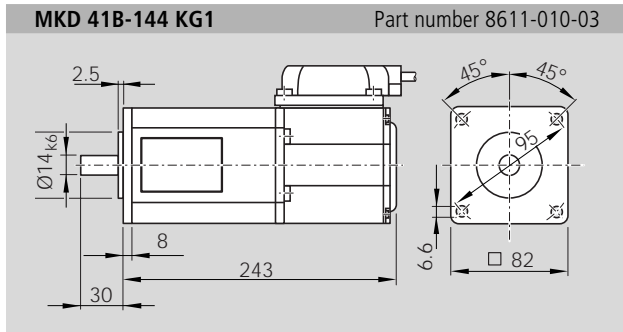

For the data of the AC servomotors, see "Motor Data" and catalog "Controllers, Motors, Electrical Accessories" RE 82 701.

Dimensions of MiniDrive

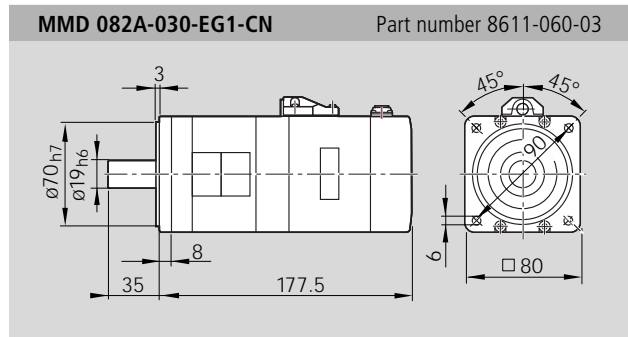

The motors can be supplied as complete units with control system.
For further details on the motors and controllers, see catalog **RE 82 701**.
Drawings to different scales.

STAR – Ball Rail Tables Accessories

Documentation

Standard report

Option 01

The standard report serves to confirm that the checks listed in the report have been carried out and that the measured values lie within the permissible tolerances.

- Checks listed in the standard report:
- functional checks of mechanical components
 - functional checks of electrical components
 - design is in accordance with order confirmation

Moment of friction measurement of the complete system

Option 02

The moment of friction is measured over the entire travel range.

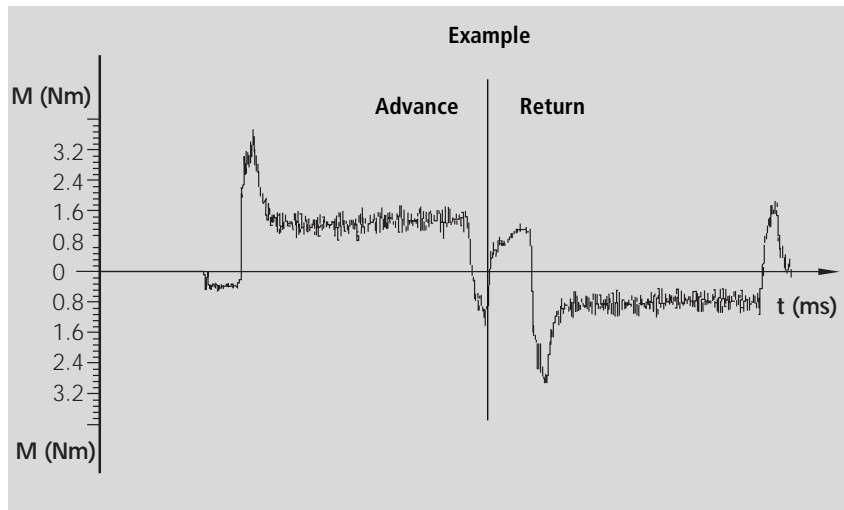

Lead deviation of ball screw

Option 03

In addition to the graph (see diagram), a measurement report in table form is provided.

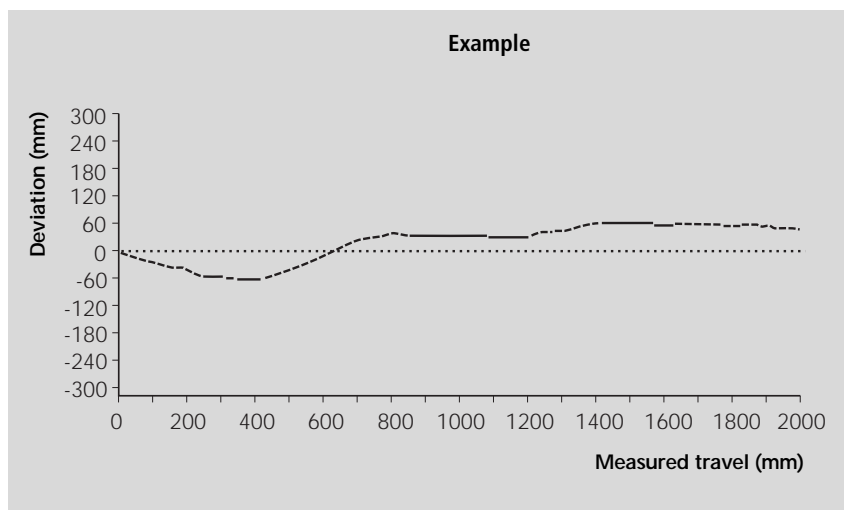

Sequence accuracy

Option 04

Several measuring points are passed during the total travel.

The following deviations are permitted:

Yawing

Yawing is angular deviation about the vertical axis. This angular deviation is converted to a linear deviation in mm on the basis of a standard length and is plotted on the graph.

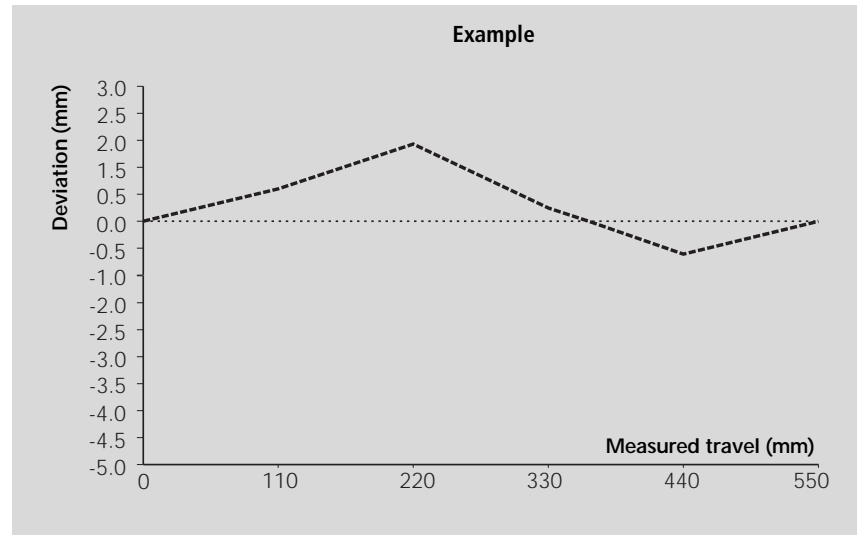
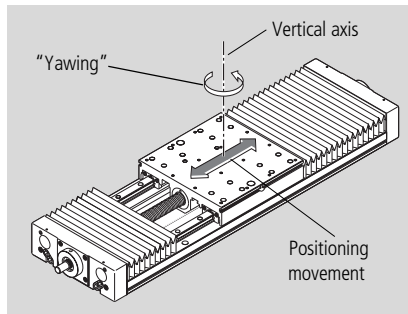

Pitching

Pitching means angular deviation about the horizontal axis. This angular deviation is converted into a linear deviation in mm on the basis of a standard length and is plotted on the graph.

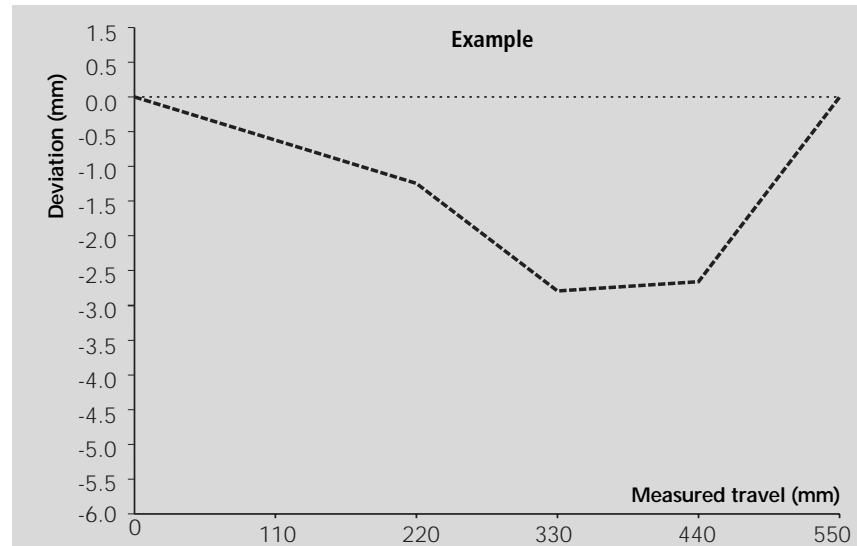
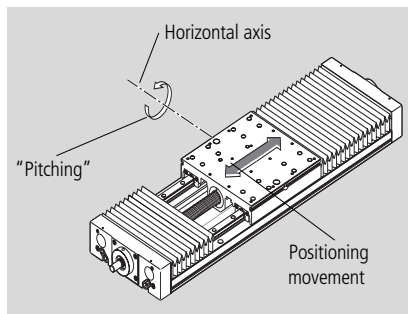

In addition to graphical representation (see illustrations), a measurement report is supplied in table form.

STAR – Ball Rail Tables Accessories

Documentation

Positioning accuracy

to VDI/DGQ 3441

Option 05

Measurement points are selected at irregular intervals along the travel. This enables even periodical deviations to be detected during positioning. Each measurement point is approached several times from both sides. This will give the following parameters.

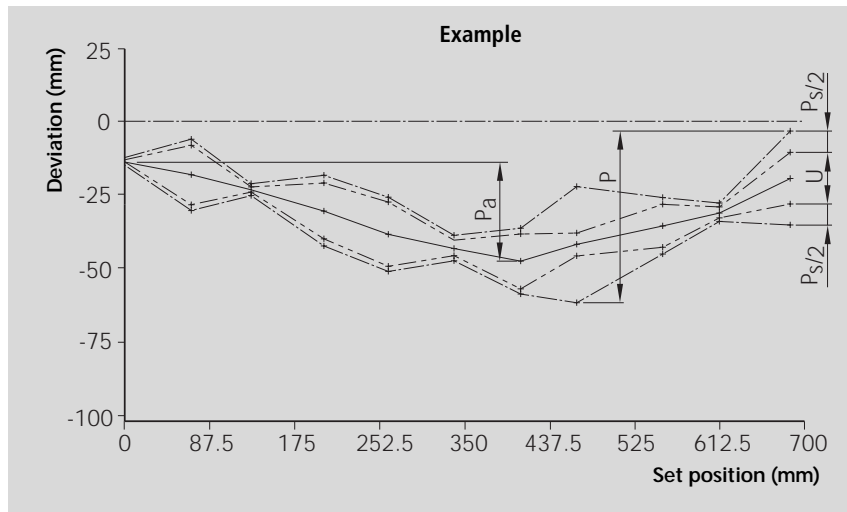

Positioning accuracy P

The positioning accuracy corresponds to the total deviation. It encompasses all the systematic and random deviations during positioning.

The positioning accuracy takes the following characteristic values into consideration:

- positioning deviation
- reversal range
- position variation range

Positioning deviation P_a

The positioning deviation corresponds to the maximum difference arising in the mean values of all the measurement points. It describes systematic deviations.

Reversal range U

The reversal range corresponds to the difference in mean values of the two approach directions. The reversal range is determined at every measurement point. It describes systematic deviations.

Position variation range P_s

The position variation range describes the effects of random deviations. It is determined at every measurement point.

Mounting accessories

TKK 15-155 AI

Part number
8447-001-01

T-nut

Part number
0391-750-03

T-nut

**TKK 20-225 AI
TKK 30-325 AI**

Part number
8447-010-02

T-nut

TKK 35-455 AI

Part number
8447-006-01

T-nut

Part number
8454-030-49

Fixing spring for
T-nut 8447-006-01

STAR – Ball Rail Tables

Connection System

STAR cross plates are used for simple construction of X-Y units. They are supplied as complete assemblies with all screws, pins and T-nuts necessary for joining the two axes together.

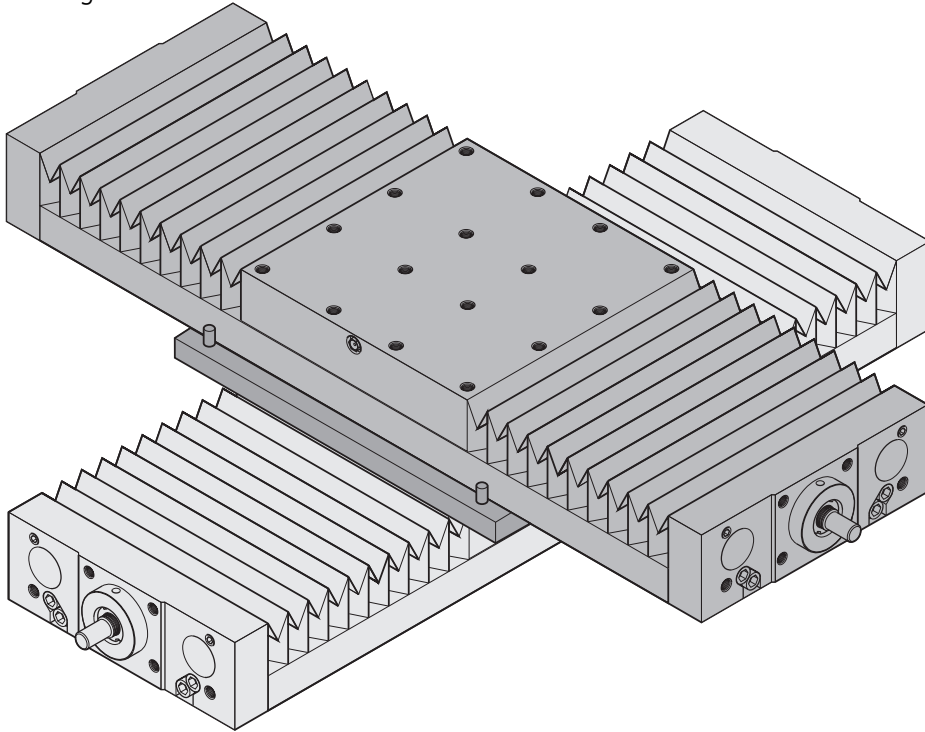

The connection system is designed so that ball rail tables of both identical ...

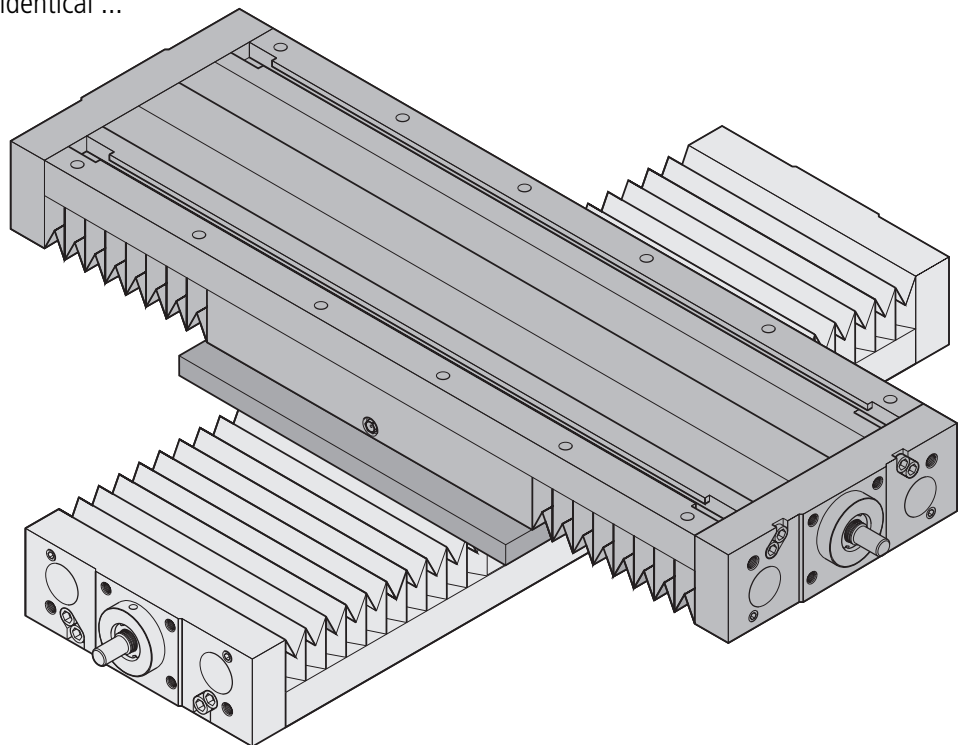

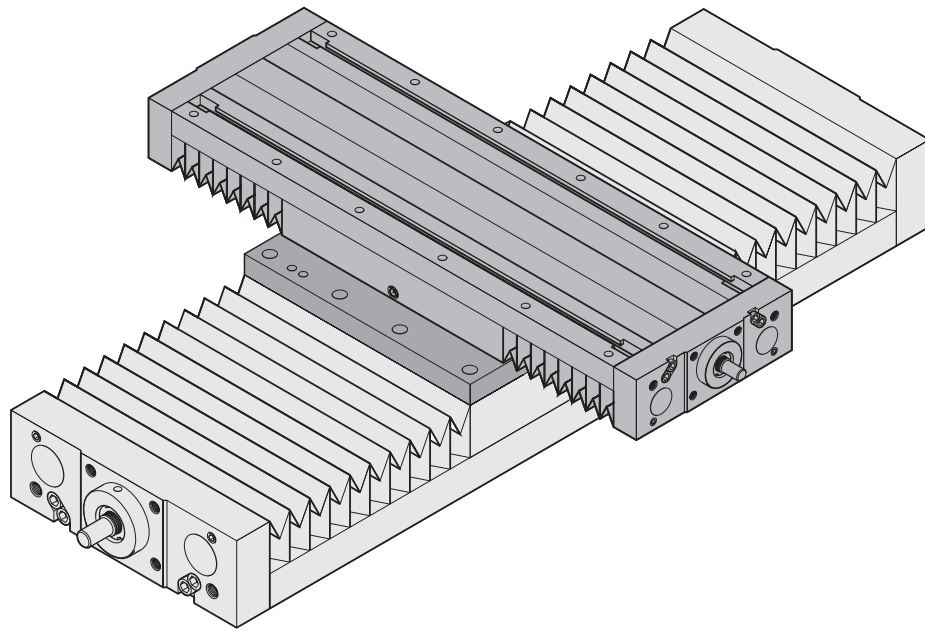

... and next largest or smallest sizes can be combined.

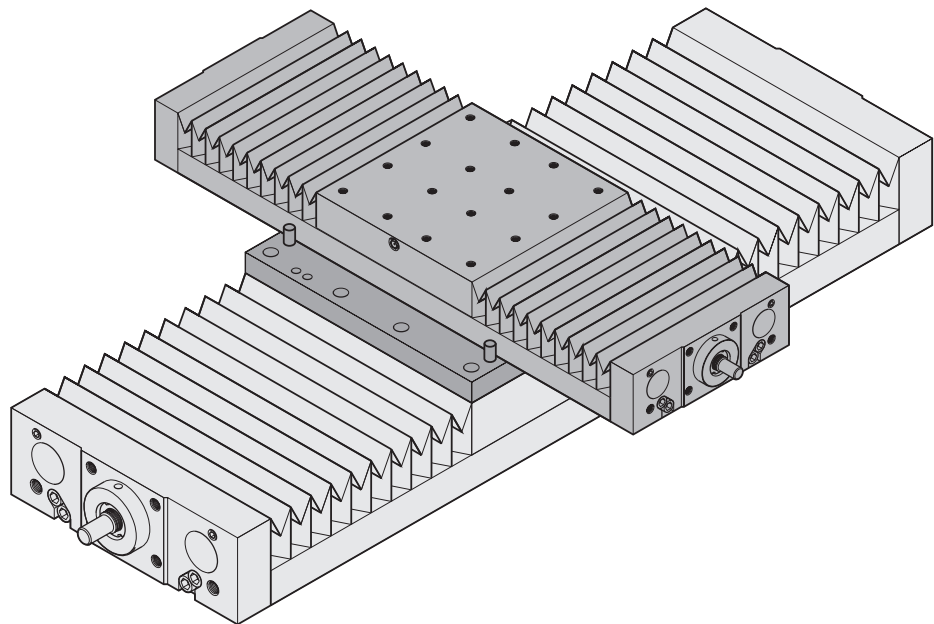

STAR – Ball Rail Tables Connection System

General

In a two-axis unit, the accuracies of the individual axes and of the cross plate are added, together with the elastic deformation of the Y-axis (not fully supported). However, this deformation can be significantly reduced by the use of the high base plate. The perpendicularities described in the graphs are calculated maximum values and describe the angular relation of the two axes to each other. They are attained by simple joining and fixing together using existing or predrilled pin-holes, without requiring alignment. More precise perpendicularities can be produced by aligning the Y-axis and drilling the predrilled pin-holes in the cross plate. The P4 accuracies of the individual axes must be added to the specified angularity.

Assemblies for connection of base plate to carriage

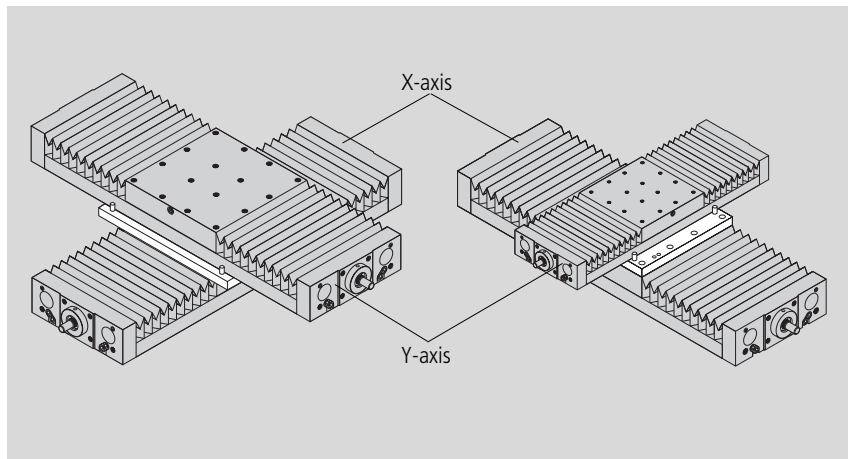

Part numbers of cross plate assemblies

Comprising: cross plate with all fixings required to join the two axes.

| X-axis | Y-axis | | |
|---------------|---------------|---------------|---------------|
| | TKK 15-155 AI | TKK 20-225 AI | TKK 30-325 AI |
| TKK 15-155 AI | 0391-200-11 | | |
| TKK 20-225 AI | 0391-200-13 | 0391-200-15 | |
| TKK 30-325 AI | | 0391-200-17 | 0391-200-19 |
| TKK 35-455 AI | | | 0391-200-21 |

Perpendicularity of the two axes

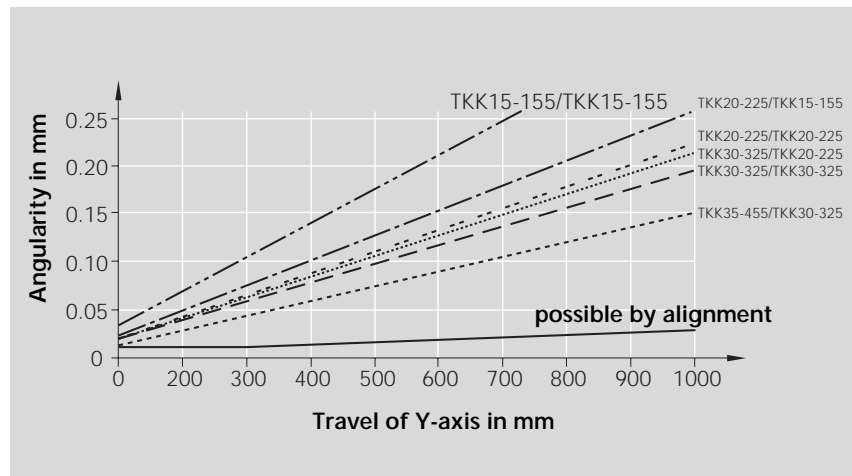

Note

Fully assembled cross plates and combinations of steel ball rail tables available on request.

In the case of motor attachment via side drive with timing belt, the motor may project into the working area of adjacent axes. Check interference edges.

Assemblies for connection of carriage to carriage

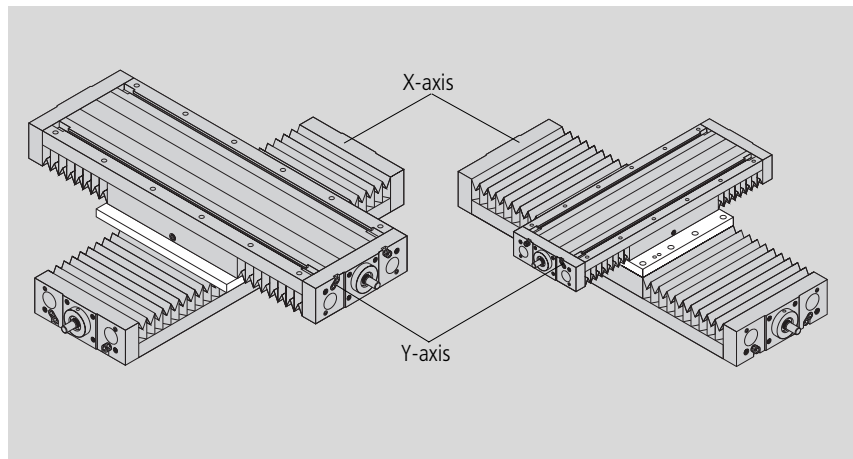

Part numbers of cross plate assemblies

Comprising: cross plate with all fixings required to join the two axes.

| X-axis | Y-axis | | |
|---------------|-----------------------------------|-----------------------------------|-----------------------------------|
| | TKK 15-155 AI with $L_T = 220$ | TKK 20-225 AI with $L_T = 320$ | TKK 30-325 AI with $L_T = 450$ |
| TKK 15-155 AI | 0391-200-12 | | |
| TKK 20-225 AI | 0391-200-14 | 0391-200-16 | |
| TKK 30-325 AI | | 0391-200-18 | 0391-200-20 |
| TKK 35-455 AI | | | 0391-200-22 |

L_T = Carriage length

Perpendicularity of the two axes

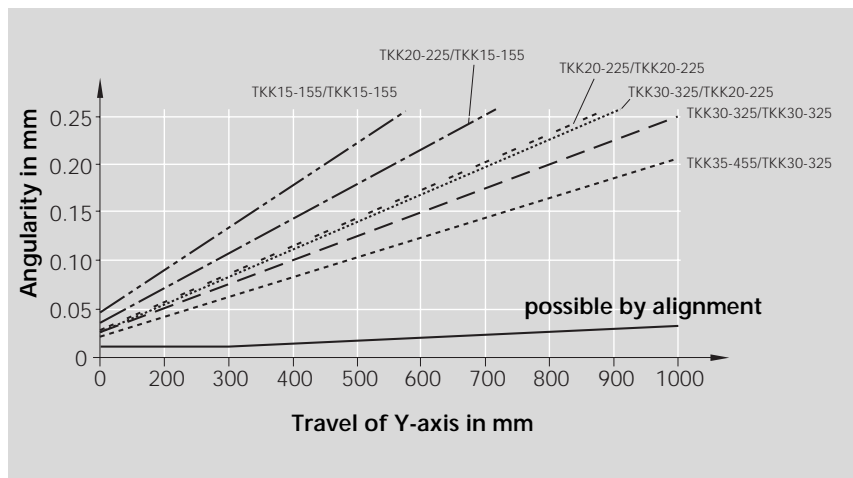

STAR – Ball Rail Tables Connection System

Dimensions of the cross plates
when connecting ball rail
tables of the same size

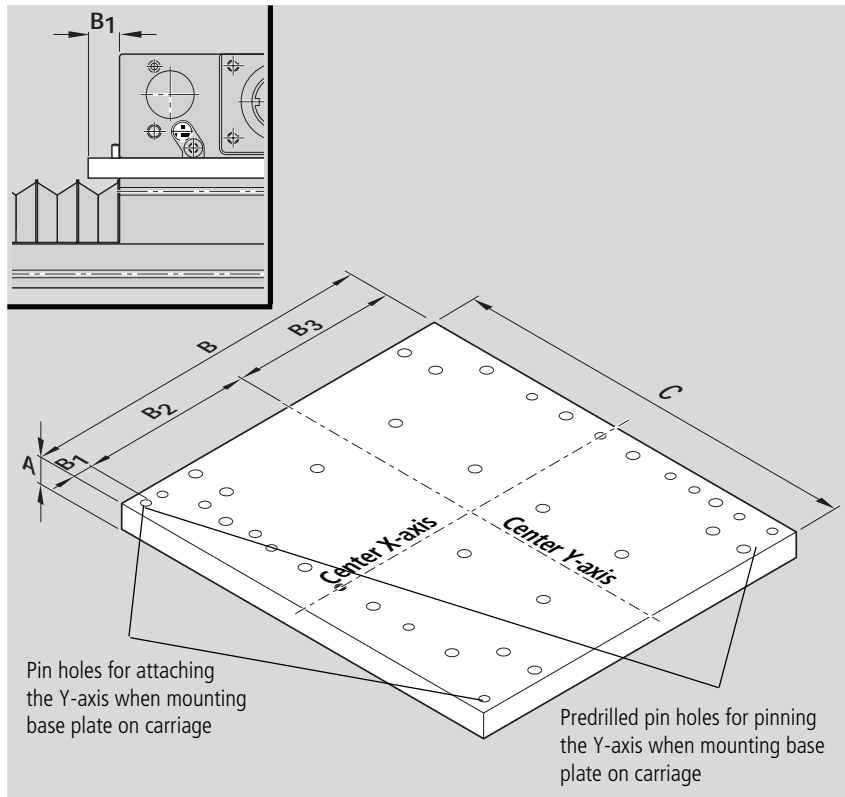
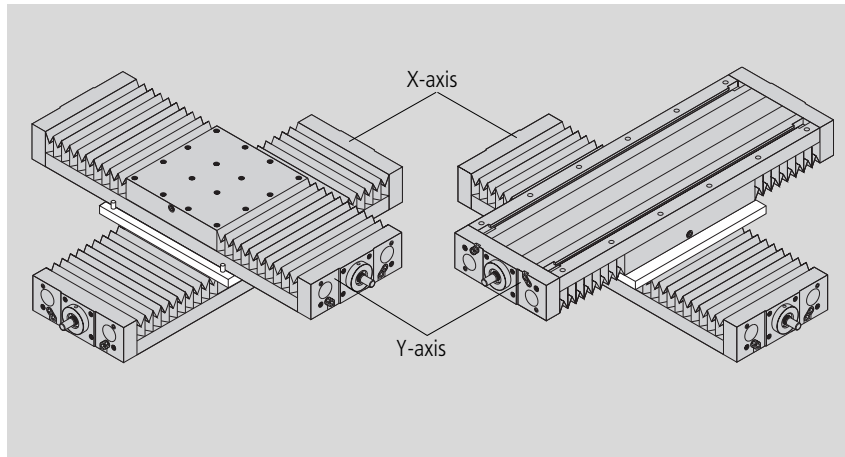

| Part number of assembly | (mm) | | | | | |
|----------------------------|------|-----|-----|----------------|----------------|----------------|
| | A | B | C | B ₁ | B ₂ | B ₃ |
| 0391-200-11 0391-200-12 | 18 | 165 | 220 | 11 | 77.5 | 76.5 |
| 0391-200-15 0391-200-16 | 18 | 240 | 320 | 16 | 112.5 | 111.5 |
| 0391-200-19 0391-200-20 | 25 | 340 | 450 | 16 | 162.5 | 161.5 |

Dimensions of the cross plates when connecting ball rail tables of adjacent sizes

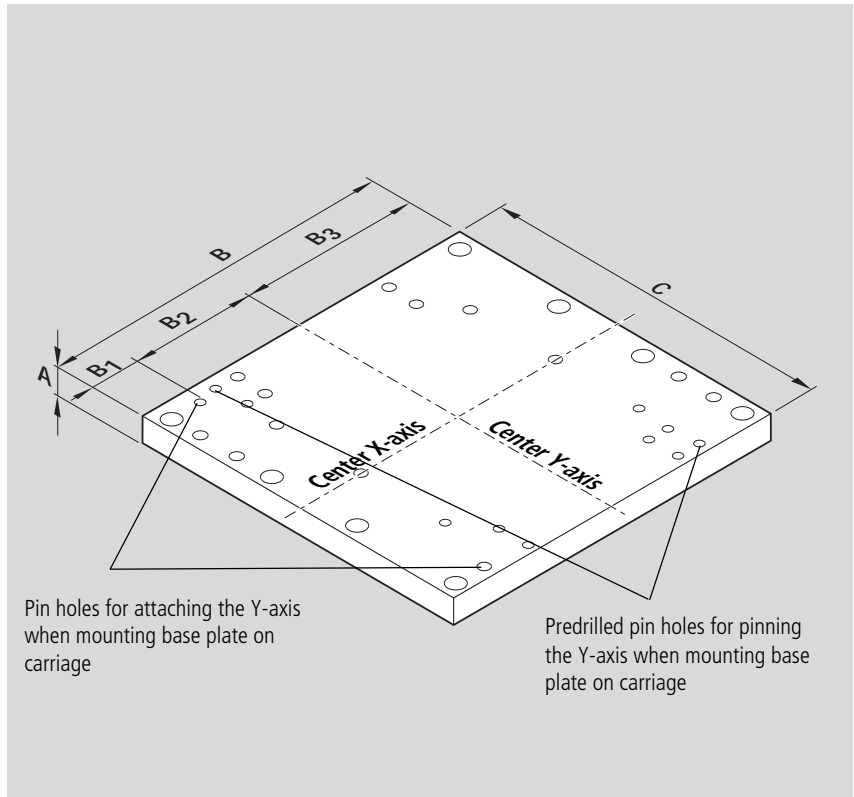
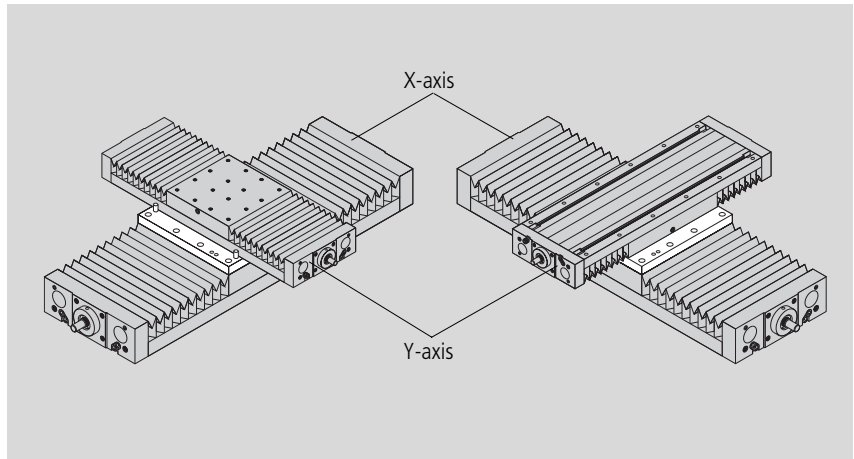

| Part number of assembly | (mm) | | | | | |
|----------------------------|------|-----|-----|----------------|----------------|----------------|
| | A | B | C | B ₁ | B ₂ | B ₃ |
| 0391-200-13 0391-200-14 | 18 | 220 | 220 | 32.5 | 77.5 | 110 |
| 0391-200-17 0391-200-18 | 18 | 320 | 320 | 47.5 | 112.5 | 160 |
| 0391-200-21 0391-200-22 | 25 | 400 | 450 | 37.5 | 162.5 | 200 |

Inquiry/Order Form

Rexroth Star
 14001 South Lakes Drive
 Charlotte, NC 28273

Telephone 800/438-5983
 Telefax 704/583-4338

STAR – Ball Rail® Tables

| Order example | | | |
|------------------------------------|--|--|---|
| TKK 20-225 St 1460-300-00, 1660 mm | | | ball rail table, length L = 1660 mm |
| Type = RV04 | | | with side drive with timing belt, mounted as in diagram RV04 |
| Guideway = 01 | | | base plate, flat |
| Drive unit = 09 | | | ball screw 20 x 20 (drive via floating bearing journal, dia 14) |
| Carriage = 01 | | | one carriage 220 mm long, preload 2 % |
| Motor attachment = 39 | | | with side drive with timing belt with MHD 71A, i = 2 |
| Motor = 61 | | | with motor MHD 71A |
| Cover = 01 | | | polyurethane bellows |
| Position measuring system = 00 | | | without glass scale |
| 1st switch = 15-A + 500 mm | | | mechanical switch, external, switch activation point + 500 mm |
| 2nd switch = 11-A ± 0 mm | | | PNP NC, external, switch activation point ± 0 mm |
| 3rd switch = 15-A - 500 mm | | | mechanical switch, external, switch activation point - 500 mm |
| Cable duct = 20-X 1500 mm | | | cable duct 1500 mm long (loose) |
| Socket-plug = 17 | | | external socket-plug for switches (loose) |
| Switching cam = 26 | | | with external switching cam (for switch activation) |
| Documentation = 01 | | | with standard report |

To be completed by customer: Inquiry / Order

TKK - - , Length mm

Type

Guideway

Drive unit

Carriage

Motor attachment

Motor

Cover

Position measuring system

1st switch - ○ mm

2nd switch - ○ mm

3rd switch - ○ mm

Cable duct - mm

Socket-plug

Switching cam

Documentation

Please check whether the selected combination is a permissible one (load capacities, moments, maximum speeds, motor data, etc.)!

Quantity: _____ pcs, _____ per month, _____ per year, per order, or _____

Comments:

From OEM User Distributor

Company: _____ Contact: _____

Address: _____ Department: _____

Phone: _____ Fax: _____



STAR – Ball Rail Tables

Bosch Rexroth Linear Motion and Assembly Technologies division offers a complete line of STAR linear motion products...

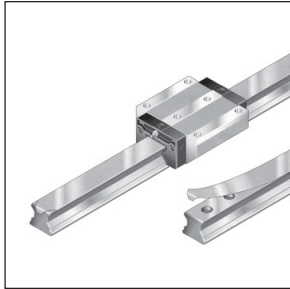

STAR Ball Rail® Systems
RA 82 201

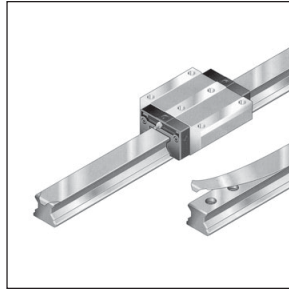

STAR Roller Rails™
RA 82 301

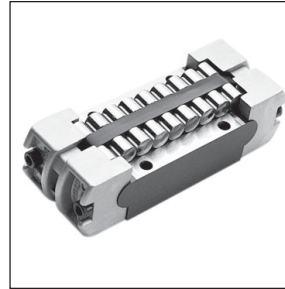

Tychoway® Linear Roller Bearings
RA 99 001

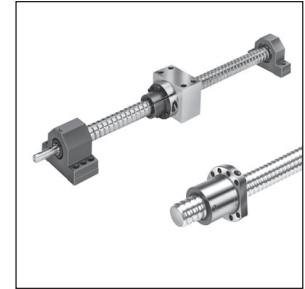

STAR Precision Ball Screws
RA 83 301

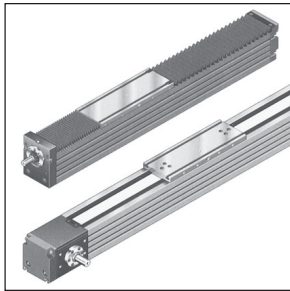

STAR Linear Modules
RA 82 402

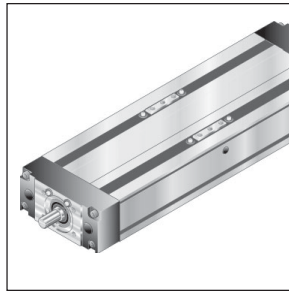

STAR Compact Modules
RA 82 601

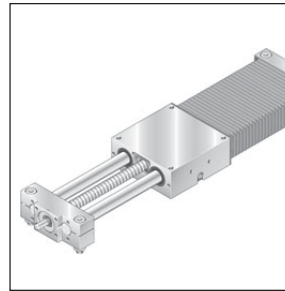

STAR Linear Motion Slides
RA 83 001

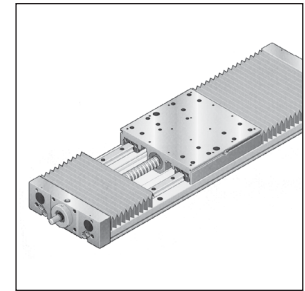

STAR Ball Rail® Tables
RA 82 501

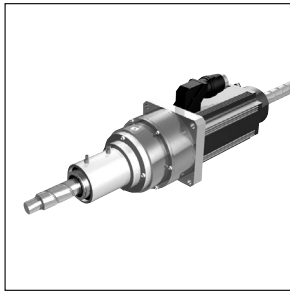

Hollow Shaft Motor
RA 83 315

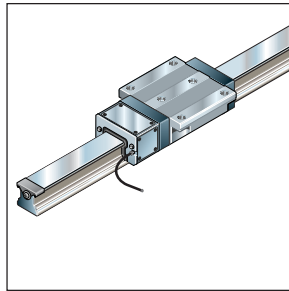

Integrated Measuring System
RA 82 350



Metric Linear Bushings
RA 83 100



Inch Linear Bushings
RA 99 110



STAR Ball Transfers
RA 82 910

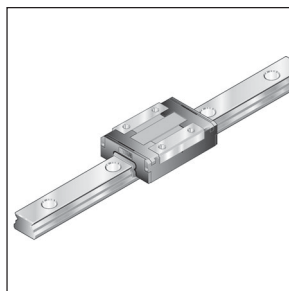

Miniature Ball Rail®
Systems
RA 82 210

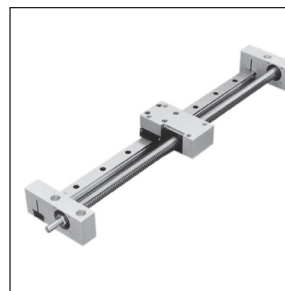

Mini Compact Slides
RA 99 007

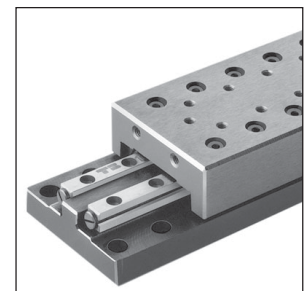

Tychoway® Roller Slides
RA 99 000

Rexroth
Bosch Group

Bosch Rexroth Corporation

Linear Motion and Assembly Technologies

14001 South Lakes Drive • Charlotte, NC 28273 • Telephone: (704)583-4338 • (800)438-5983

Telefax: (704)583-0523 • <http://boschrexroth-us.com> • E-mail: info.chr@boschrexroth-us.com

STAR, Ball Rail, and  are registered trademarks of Deutsche Star GmbH, Schweinfurt, Germany

Copyright
© BOSCH REXROTH 2001
All rights reserved.

Supersedes all previous issues.
The illustrations and drawings in the catalog show principles of design or operation and are for reference only, subject to alteration without notice.

This catalog or any part thereof may not be reproduced without our written permission.