

Miniature Ball Rail[®] Systems

The Drive & Control Company



Linear Motion Systems

Ball Rail System

Standard Ball Rail Systems
 Super Ball Rail Systems
 Ball Rail Systems with Aluminum Runner Blocks
 High-Speed Ball Rail Systems
 Corrosion-Resistant Ball Rail Systems
 Wide Ball Rail Systems

Ball Rail Systems with Integrated Measuring System
 Clamping and Braking Units for Ball Rail Systems
 Rack and Pinion for Ball Rail Systems
 Miniature Ball Rail Systems
 Cam Roller Guides

Roller Rail Systems

Standard Roller Rail Systems
 Wide Roller Rail Systems
 Heavy Duty Roller Rails Systems
 Roller Rail Systems with Integrated Measuring System
 Clamping and Braking Units for Roller Rail Systems
 Rack and Pinion for Roller Rail Systems

Linear Bushings and Shafts

Linear Bushings, Linear Sets
 Shafts, Shaft Support Rails, Shaft Support Blocks

Ball Transfer Units
 Traditional Engineering Components

Screw Drives

Linear Motion Systems

Linear Motion Slides

- Ball Screw Drive
- Toothed Belt Drive

Linear Modules

- Ball Screw Drive
- Toothed Belt Drive
- Rack and Pinion Drive
- Pneumatic Drive
- Linear Motor

Compact Modules

- Ball Screw Drive
- Toothed Belt Drive
- Linear Motor

Cartesian Motion System CMS

Precision Modules

- Ball Screw Drive

Ball Rail Tables

- Ball Screw Drive
- Linear Motor

Controllers, Motors, Electrical Accessories

Linear Actuators

Product Overview		4
General Technical Data and Calculations		6
Mounting Instructions		13
Standard Runner Blocks	R0442	14
– Dimensions and Part Numbers		14
Long Runner Blocks	R0444	16
– Dimensions and Part Numbers		16
Standard Guide Rails	R0445	18
– Dimensions and Part Numbers		18
Wide Runner Blocks	R0443	20
– Dimensions and Part Numbers		20
Wide Guide Rails	R0455	22
– Dimensions and Part Numbers		22
Start-up and Maintenance		24

Product Overview

The Miniature version of the Ball Rail System has been developed specifically for the precision engineering sector, i.e. for the production of optical or electronic data processing devices, where rolling-element linear motion guideways of extremely compact dimensions and high load capacity are required.

The linear motion guideways have equal load capacities in all four major directions of load application.

- ▶ High load capacity in all directions of load application, including moments about all axes, due to construction with the largest possible ball size

- ▶ Lubrication access from either front or side faces, dependent upon size

Size 15

- ▶ Cover strip as an option (made of stainless steel)

Size 9/M3

- ▶ Low friction

- ▶ All steel parts of the runner block and the guide rail are made of rust and acid resistant material similar to ISO 683-17 / EN 10088

CAD files available on CD-ROM

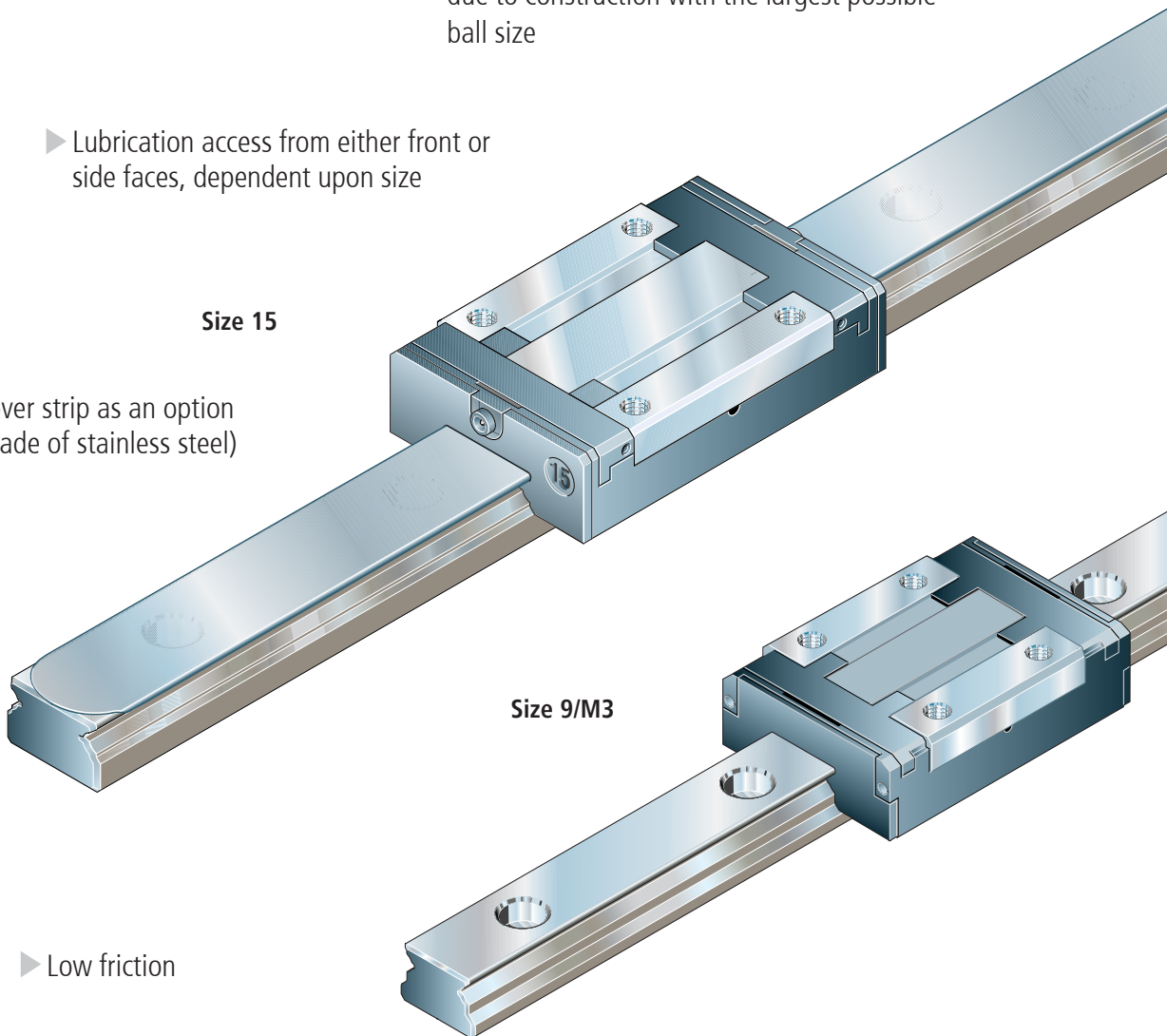

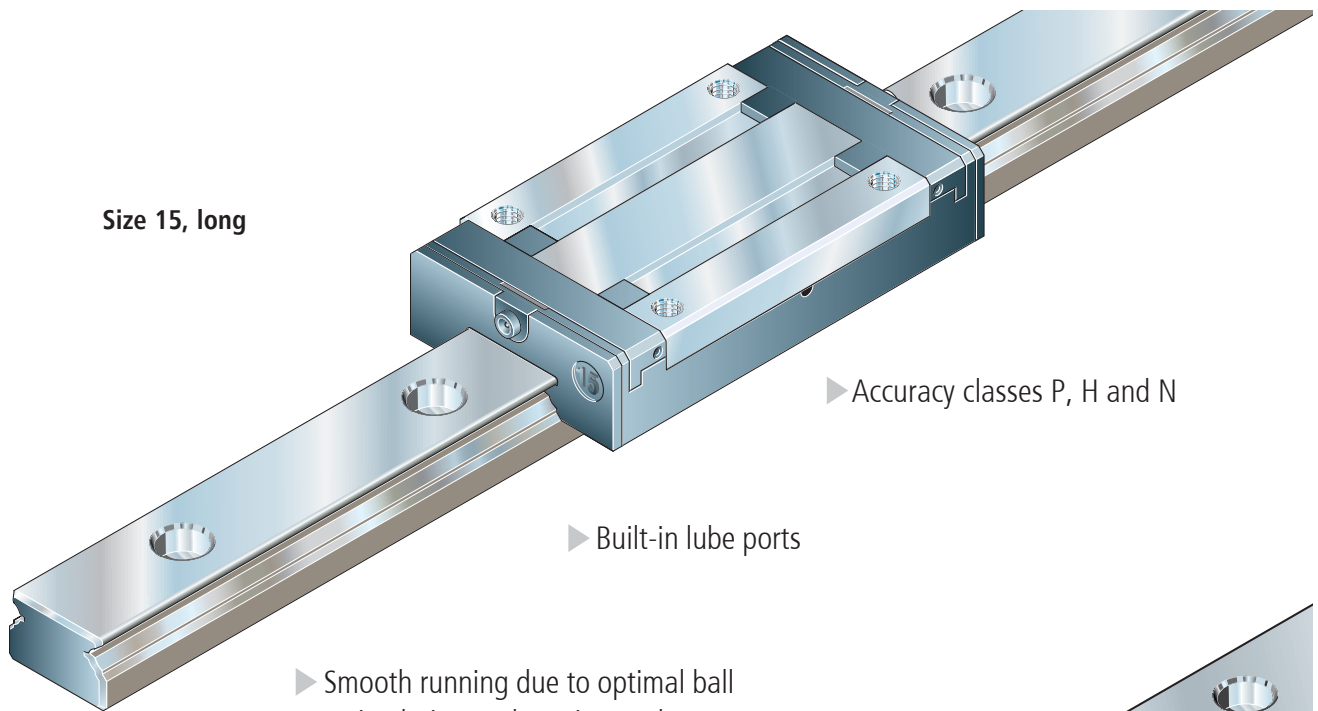

Size 15, long

▶ Accuracy classes P, H and N

▶ Built-in lube ports

▶ Smooth running due to optimal ball recirculation and precise track geometry

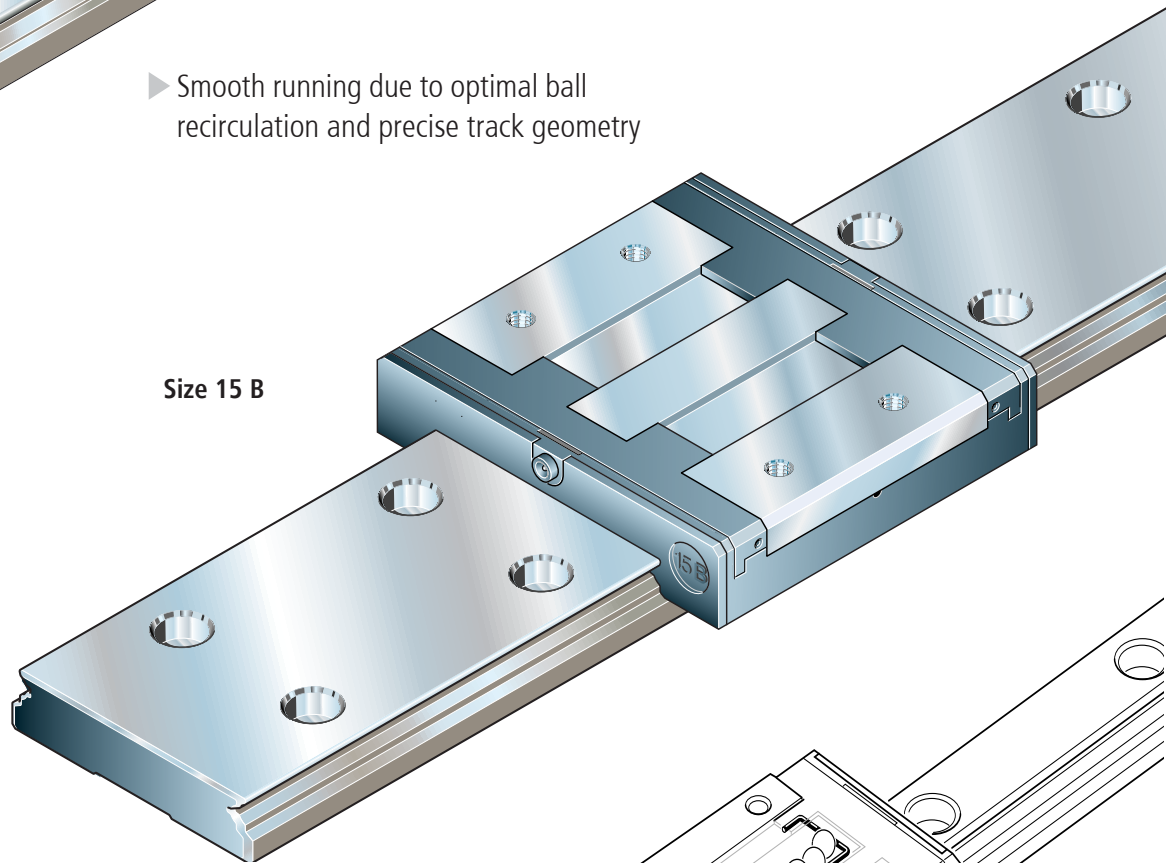

Size 15 B

▶ Built-in ball retention for safe shipping and ease of mounting

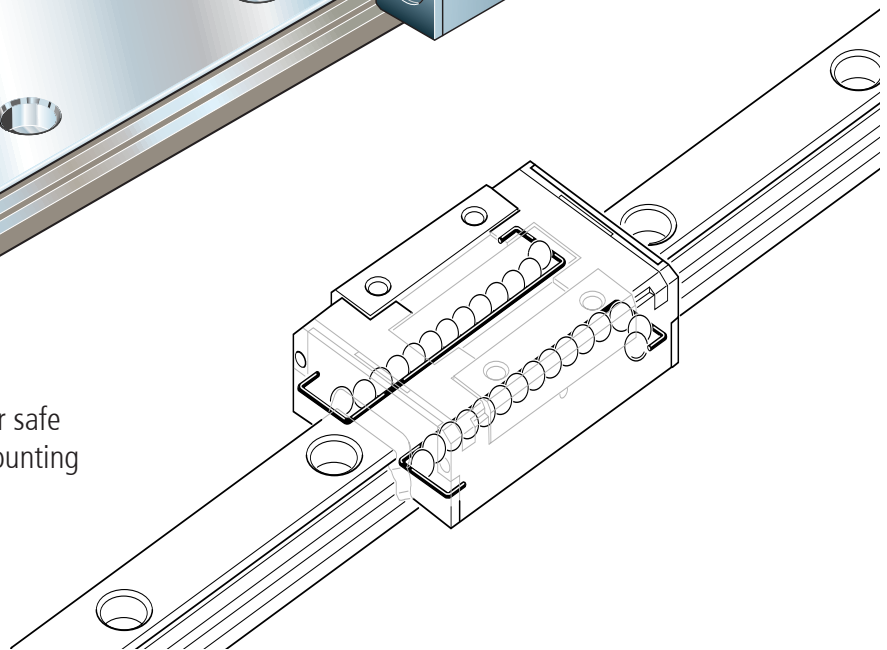

General Technical Data and Calculations

Definition of dynamic load capacity

The radial loading of constant magnitude and direction which a linear rolling bearing can theoretically endure for a

nominal life of 10^5 meters distance traveled (to DIN 636 Part 2).

Definition of static load capacity

The static loading in the direction of load which corresponds to a calculated stress of 4200 MPa at the center of the most heavily loaded rolling-element/raceway (rail) contact with a ball conformity of ≤ 0.52 , 4200 and 4600 MPa with a ball con-formity of ≥ 0.6 , 4600 MPa.

Note:

With this contact stress, a permanent total deformation of the rolling element and the raceway will occur at the contact point corresponding to approx. 0.0001 times the rolling element diameter (to DIN 636 Part 2).

Definition and calculation of the nominal life

The calculated service life which an individual linear rolling bearing, or a group of apparently identical rolling element bearings operating under the same conditions,

can attain with a 90% probability, with contemporary, commonly used materials and manufacturing quality under conventional operating conditions (to DIN 636 Part 2).

Calculate the nominal life L or L_h according to formulas (1), (2) or (3):

Nominal life with constant speed

$$L = \left(\frac{C}{F}\right)^3 \cdot 10^5$$

$$(2) \quad L_h = \frac{L}{2 \cdot s \cdot n \cdot 60}$$

L = nominal life [m]
 L_h = nominal life [h]
 C = dynamic load capacity [N]
 F = equivalent load [N]
 s = length of stroke [m]
 n = stroke repetition rate (complete cycles/min.) [min^{-1}]

Nominal life with variable speed

$$(3) \quad L_h = \frac{L}{60 \cdot v_m}$$

$$(4) \quad v_m = \frac{t_1 \cdot v_1 + t_2 \cdot v_2 + \dots + t_n \cdot v_n}{100}$$

L = nominal life [m]
 L_h = nominal life [h]
 v_m = average speed [m/min]
 v_1, v_2, \dots, v_n = discrete speed steps [m/min]
 t_1, t_2, \dots, t_n = percentage of stroke covered at v_1, v_2, \dots, v_n [%]

Equivalent dynamic load on bearing for calculation of service life

– with variable load on bearing

If the bearing is subject to variable loads, the equivalent dynamic load F must be calculated according to formula (5):

$$(5) \quad F = \sqrt[3]{F_1^3 \cdot \frac{q_1}{100} + F_2^3 \cdot \frac{q_2}{100} + \dots + F_n^3 \cdot \frac{q_n}{100}}$$

F = equivalent load [N]
 F_1, F_2, \dots, F_n = discrete load steps [N]
 q_1, q_2, \dots, q_n = percentage of stroke covered under F_1, F_2, \dots, F_n [%]

– with combined load on bearing

The equivalent dynamic load F resulting from combined vertical and horizontal loads is calculated according to formula (6):

Note:

The structure of the Ball Rail System permits this simplified calculation.

<p>(6) $F = F_V + F_H$</p>	<p>F = equivalent dynamic load [N] F_V = external dynamic load, vertical [N] F_H = external dynamic load, horizontal [N]</p>
---	---

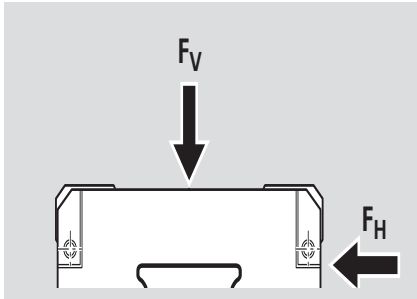

Note

If F_V and F_H involve several different load levels, they have to be calculated separately using formula (5).

An external load acting at an angle on the runner block is to be broken down into its F_V and F_H components and these values then used in formula (6).

– with combined load in combination with a moment

For a combined external load – vertical and horizontal – in conjunction with a moment, calculate the equivalent dynamic load F according to formula (7):

Formula (7) applies only when using a single rail.

<p>(7) $F = F_V + F_H + C \cdot \frac{ M }{M_t}$</p>	<p>F = equivalent dynamic load [N] F_V, F_H = external dynamic loads [N] M = dynamic moment [Nm] C = dynamic load capacity * [N] M_t = permissible dyn. moment * [Nm] * see tables</p>
---	--

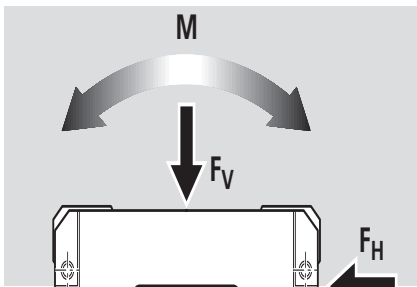

Note

If F_V and F_H involve several different load levels, they have to be calculated separately using formula (5).

An external load acting at an angle on the runner block is to be broken down into its F_V and F_H components and these values then used in formula (7).

Equivalent static load on bearing

For a combined external static load – vertical and horizontal – in conjunction with a static moment, calculate the equivalent static load F_0 according to formula (8):

The equivalent static load F_0 must not exceed the static load capacity C_0 .

Formula (8) applies only when using a single rail.

<p>(8) $F_0 = F_{V0} + F_{H0} + C_0 \cdot \frac{ M_0 }{M_{t0}}$</p>	<p>F_0 = equivalent static load [N] F_{V0}, F_{H0} = external static loads [N] M_0 = static moment [Nm] C_0 = static load capacity * [N] M_{t0} = permissible static moment * [Nm] * see tables</p>
--	---

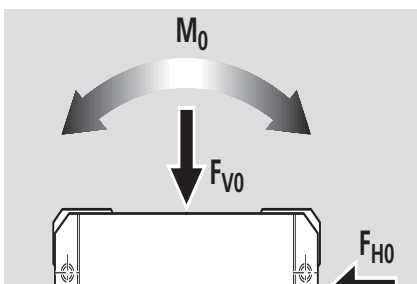

Note

An external load acting at an angle on the runner block is to be broken down into its F_{V0} and F_{H0} components and these values then used in formula (8).

Technical Data

Speed

$$v_{\max} = 3 \text{ m/s}$$

Speeds of up to 5 m/s are possible. Service life is limited by wear of plastic parts.

Acceleration

$$a_{\max} = 250 \text{ m/s}^2$$

Only with preloaded systems.
With non-preloaded systems:
 $a_{\max} = 50 \text{ m/s}^2$

Temperature resistance

$$T_{\max} = 100^\circ\text{C}$$

$$T_{\min} = -20^\circ\text{C}$$

T_{\max} only permissible for a short time
In continuous operation, do not exceed a temperature of 80°C.

Accuracy classes and their tolerances [µm]

Miniature Ball Rail Systems are offered in three different accuracy classes.

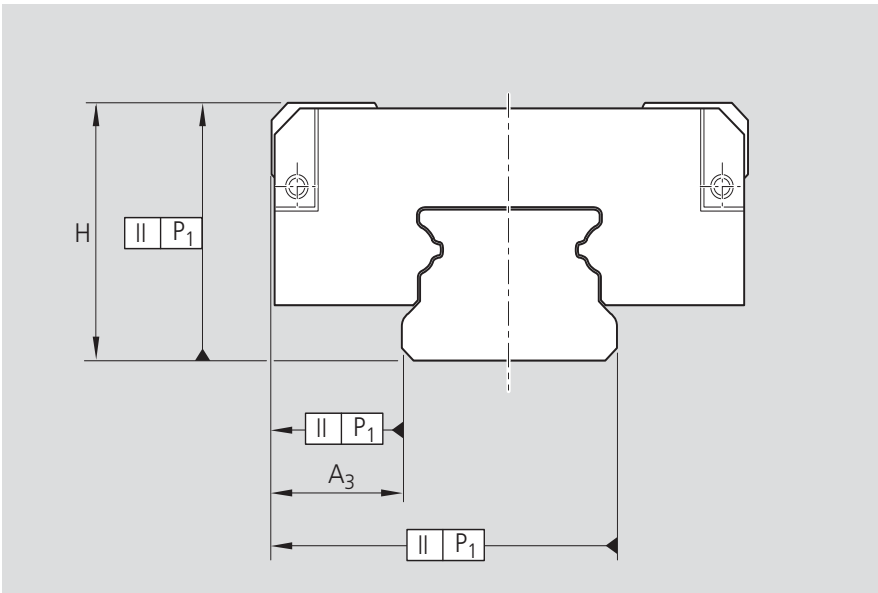

Accuracy classes	Dimensional tolerance [µm]		Max difference in dimensions H and A3 on the same rail ΔH, ΔA3 [µm]
	H	A3	
P	± 10	± 10	7
H	± 20	± 20	15
N	± 30	± 30	20

Measured at middle of runner block¹⁾:

For any block/rail combination at any position on rail

For different runner blocks at same position on rail

1) In dimensions H and ΔH, the middle of the runner block is calculated from the mean of the two measuring points shown.

Parallelism offset P_1 of the Ball Rail System in service

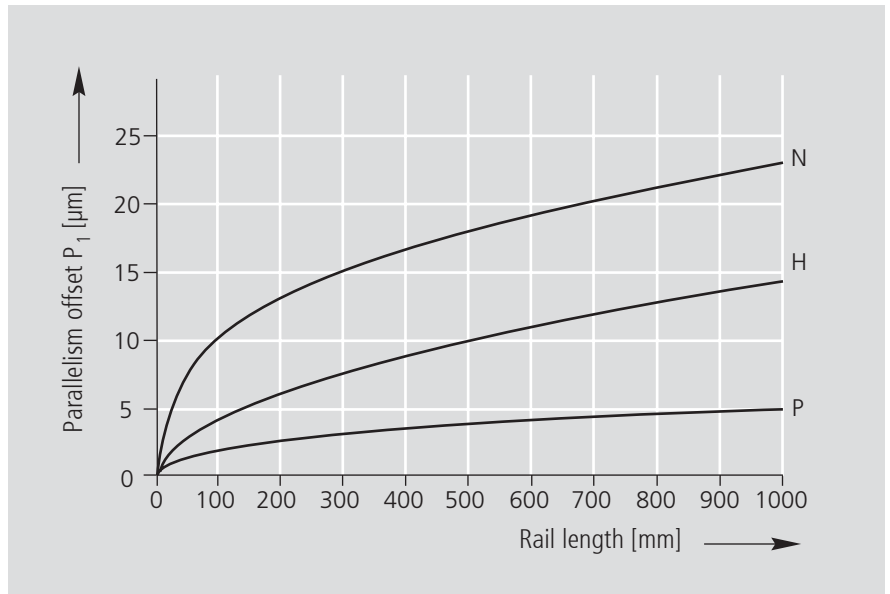

Parallelism of the installed rails

measured on the guide rails and on the runner blocks

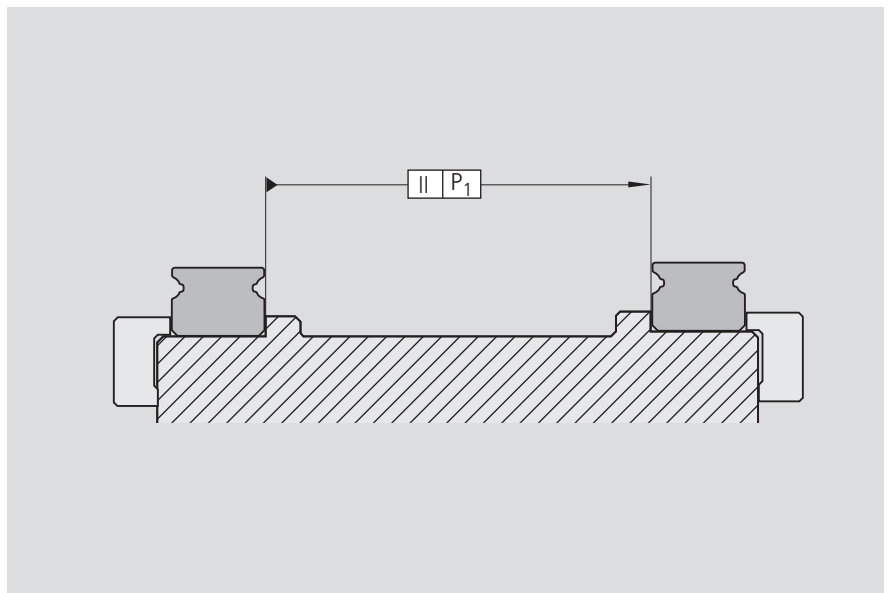

Size	Parallelism offset P_1 [mm]	
	Clearance	Preload
Standard Guide Rails R0445		
7	0,004	0,002
9/M3	0,005	0,002
9/M2	0,005	0,002
12	0,008	0,004
15	0,017	0,008
20	0,025	0,016
Wide Guide Rails R0455		
9/M3 B	0,010	0,004
12 B	0,014	0,006
15 B	0,018	0,011

Technical Data

Vertical offset

Permissible vertical offset in transverse direction S_1

The permissible vertical offset S_1 includes the tolerance for dimension H (see accuracy classes).

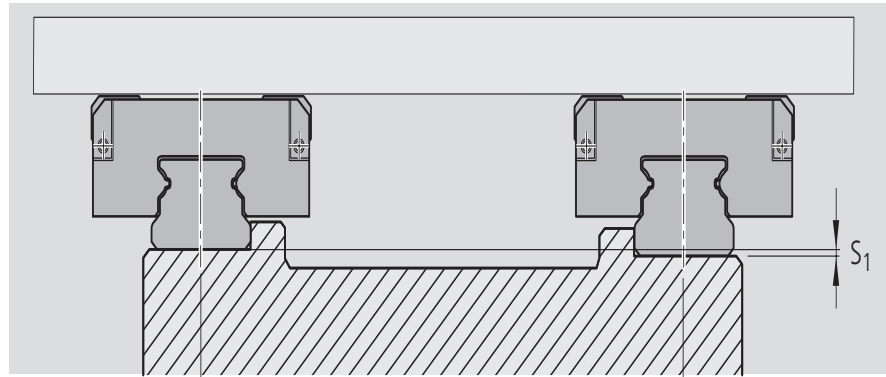

$S_1 = a \cdot Y$	S_1 = permissible vertical offset [mm] a = distance between guide rails [mm] Y = design factor
-------------------	--

Design factor	Preload class	
	Clearance	Preload
Y	$3.0 \cdot 10^{-4}$	$1.5 \cdot 10^{-4}$

Permissible vertical offset in longitudinal direction S_2

The permissible vertical offset S_2 includes the tolerance "max difference of dimension H on the same rail" ΔH (see accuracy classes).

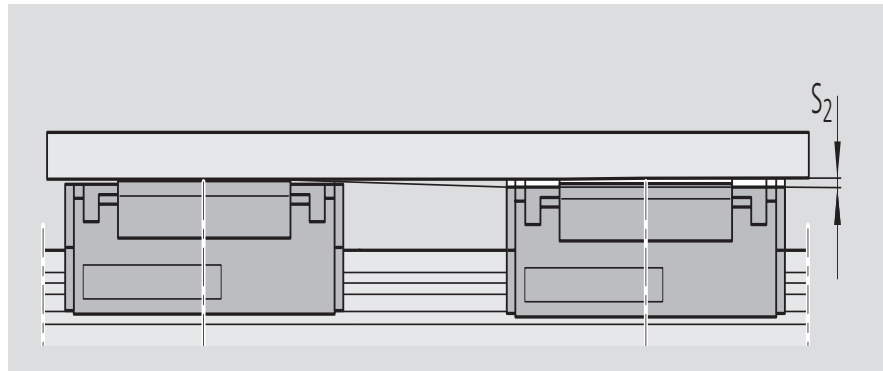

$S_2 = b \cdot 7 \cdot 10^{-5}$	S_2 = permissible vertical offset [mm] b = distance between runner blocks [mm]
---------------------------------	---

Preloading and clearance

	Accuracy class			
	P	H		N
Preload class	1	1	9	9
Preload and clearance	~0 to moderate preload	~0 to moderate preload	~0 to moderate clearance	Moderate clearance to moderate preload

Markings on runner block and guide rail

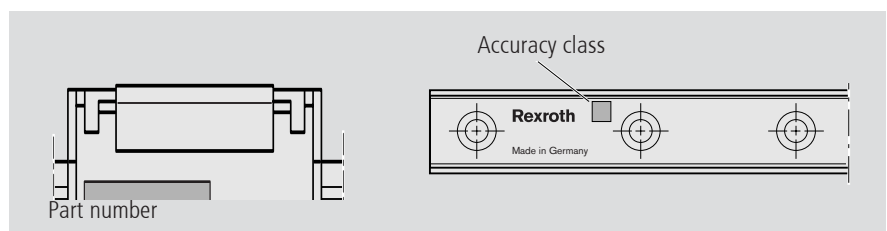

Rigidity of the Miniature Ball Rail System when preloaded

Runner block mounted with 4 screws, screw strength class 12.9

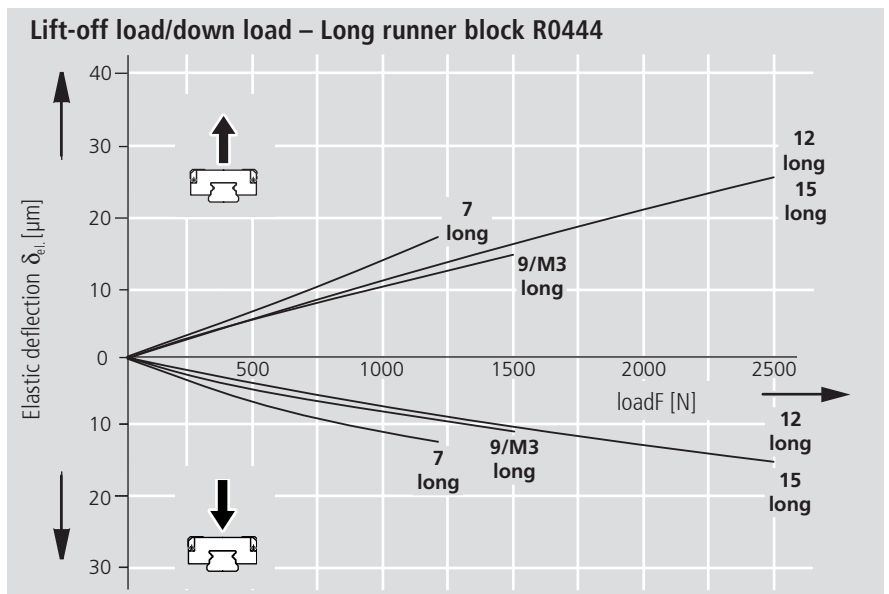
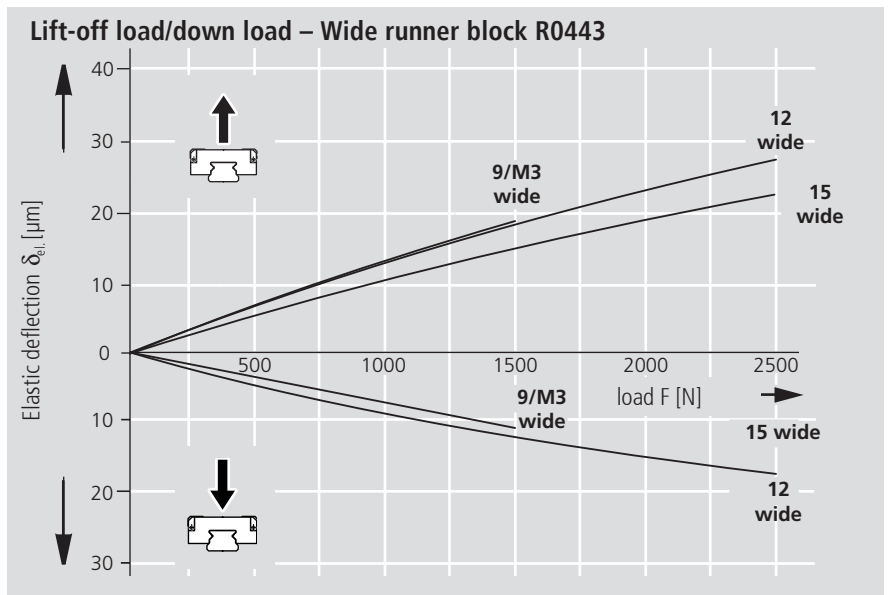
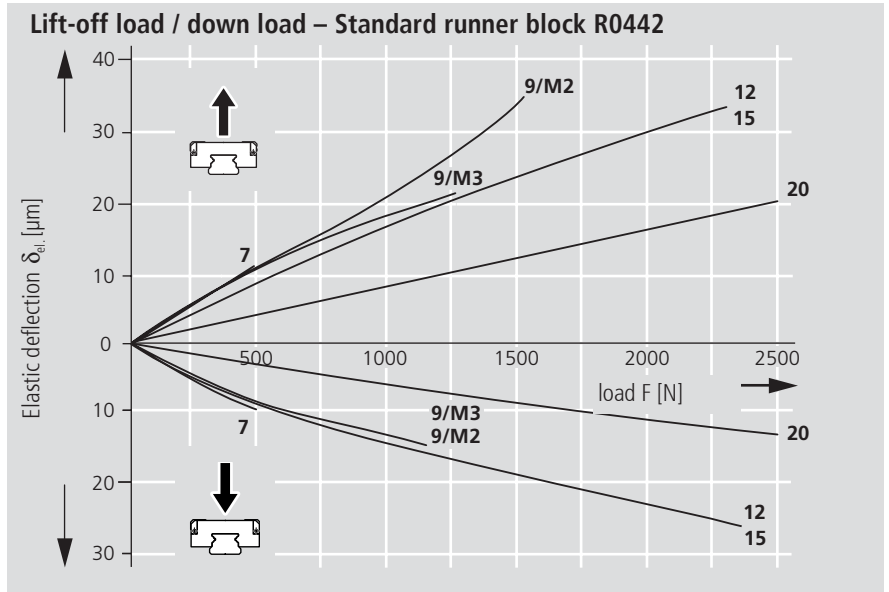

Technical Data

General Notes

The screw connections specified in the DIN 645-1 standard can be overstressed due to the high performance capability of profiled rail systems. The most critical point is the screw connection between the guide rail and the mounting base. If the **lift-off** loads (F) or moments (M) are higher than the respective load values given in the table, the screw connections have to be recalculated separately.

The data applies for the following conditions:

- Mounting screw quality 12.9
- Screws tightened using a torque wrench
- Screws lightly oiled
(for screws in quality 8.8, an approximation factor of 0.6 can be applied)

Friction and seals

The total frictional drag of the runner block is the sum of the frictional drag of the runner block and the frictional drag of the seals (see tables on right).

The runner blocks are equipped with low-friction seals as standard.

Part number: R044. ... 01

(see "Part numbers for runner blocks" tables)

Special versions:

Runner blocks are also available with N seals (excellent wiping action)

Part number: R044. ... 00

(otherwise as in "Part numbers for runner blocks" tables)

Sizes 15, 20, 9/M3 B, 12 B, 15 B and long runner blocks size 9/M3, 12 and 15 have additional longitudinal seals for full sealing.

Miniature Ball Rail Systems					
Guide Rails	Runner block R0442			Runner block R0444	
	Size	F_{max} [N]	M_{tmax} [Nm]	F_{max} [N]	M_{tmax} [Nm]
R0445	7	1000	3.2	1150	3.7
	9/M2	1080	4.3	–	–
	12	–	–	4300	23.7
	15	3740	26.0	4280	30.0
No restriction for sizes					
R0445	R0442:	9/M3, 12 and 20			
	R0444:	9/M3			
R0455	R0443:	9/M3 wide, 12 wide and 15 wide			

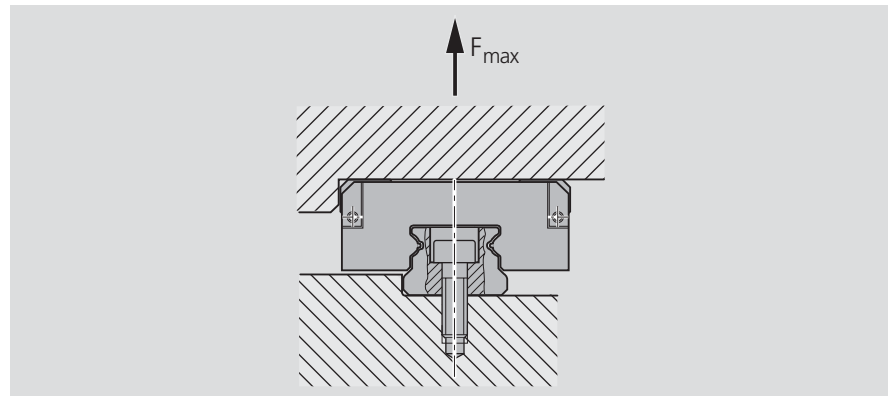

Size	Frictional drag of runner blocks (without seals)		Frictional drag of seals	
	with clearance [N]	with preload [N]	Low-friction seal (-01) [N]	N-Seal (-00) [N]
Standard Runner blocks R0442				
7	< 0,1	< 0,1	~0	0,1
9/M3	< 0,1	< 0,1	~0	0,5
9/M2	< 0,1	< 0,1	~0	0,5
12	< 0,1	< 0,2	~0	0,9
15	< 0,2	< 0,4	~0	1,2 ¹⁾
20	< 0,2	< 0,5	~0	1,5 ¹⁾
Wide Runner blocks R0443				
9/M3 B	< 0,2	< 0,3	~0	1,5 ¹⁾
12 B	< 0,2	< 0,3	~0	1,5 ¹⁾
15 B	< 0,2	< 0,4	~0	1,5 ¹⁾
Long Runner blocks R0444				
7	< 0,1	< 0,3	~0	0,2
9/M3	< 0,2	< 0,4	~0	0,6 ¹⁾
12	< 0,2	< 0,4	~0	0,9 ¹⁾
15	< 0,2	< 0,5	~0	1,0 ¹⁾

¹⁾ with longitudinal seal

Mounting Instructions

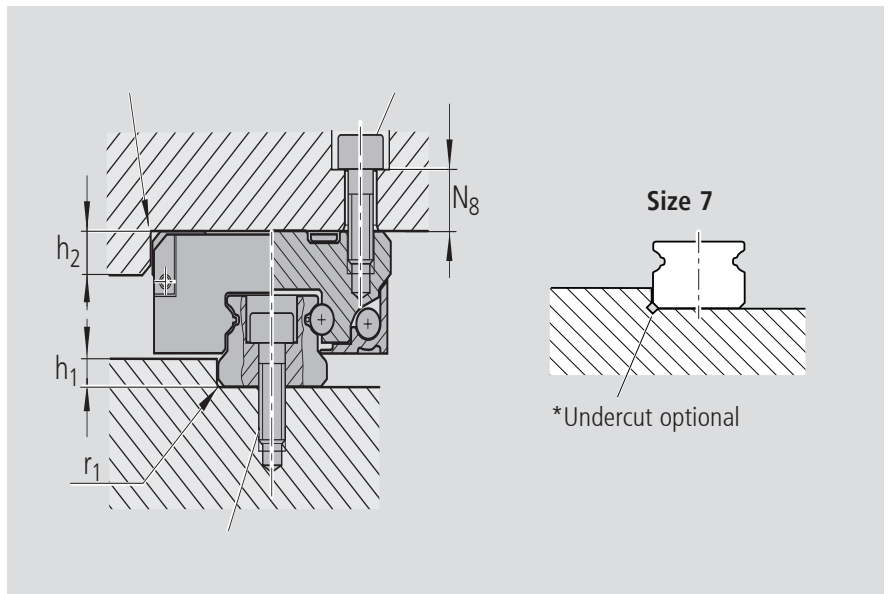

Reference edges, corner radii, screw sizes and tightening torques



Size	h ₁ [mm]	r ₁ max. [mm]	h ₂ [mm]	r ₂ max. [mm]	O ₅ ISO 4762 ¹⁾ 4 pcs	O ₃ ISO 4762 ¹⁾ (rail)	N ₈ [mm]
Standard runner block R0442-							
7	1.2 ^{-0.1}	0.1*	2.2	0.3	M2x5	M2x5	3.0
9/M3	1.5 ^{-0.2}	0.3	2.5	0.3	M3x8	M3x8	5.0
9/M2	1.5 ^{-0.2}	0.3	2.5	0.3	M2x6	M2x6	4.0
12	2.5 ^{-0.5}	0.3	3.5	0.5	M3x8	M3x8	5.0
15	2.8 ^{-0.5}	0.5	4.5	0.5	M3x8	M3x10	4.5
20	6.3 ^{-0.5}	0.5	6.5	0.5	M4x12	M5x14	6.5
Wide runner block R0443-							
9/M3 B	1.8 ^{-0.2}	0.3	2.5	0.3	M3x8	M3x8	5.5
12 B	2.8 ^{-0.5}	0.5	3.0	0.4	M3x8	M4x10	4.5
15 B	2.8 ^{-0.5}	0.5	4.5	0.5	M4x10	M4x12	6.0
Long runner block R0444-							
7	1.2 ^{-0.1}	0.1*	2.2	0.3	M2x5	M2x5	3.0
9/M3	1 ^{-0.1}	0.3	2.5	0.3	M3x8	M3x8	5.0
12	2 ^{-0.2}	0.3	3.5	0.5	M3x8	M3x8	5.0
15	2.8 ^{-0.5}	0.5	4.5	0.5	M3x8	M3x10	4.5

¹⁾ formerly DIN 912

Tightening torques of the mounting screws

	M2	M3	M4	M5
 A2-70	0.35	1.1	2.0	3.9
 Nm	12.9	2.1	4.6	9.5

Note on assembly

The runner block is supplied on a plastic mandrel.

- Position the runner block complete with the mandrel at the head of the rail and push on; the mandrel will thus be pushed out of the runner block.

When removing the runner block, carry out the above operations in reverse sequence.

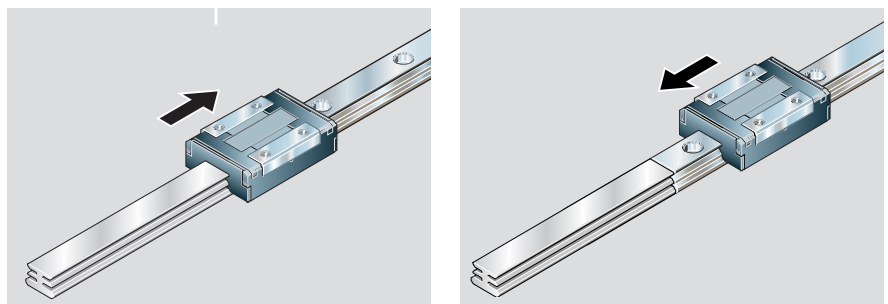

Standard Runner Block R0442

All steel parts are made of rust and acid resistant material similar to ISO 683-17 / EN 10088.

Runner blocks are supplied on mandrels.

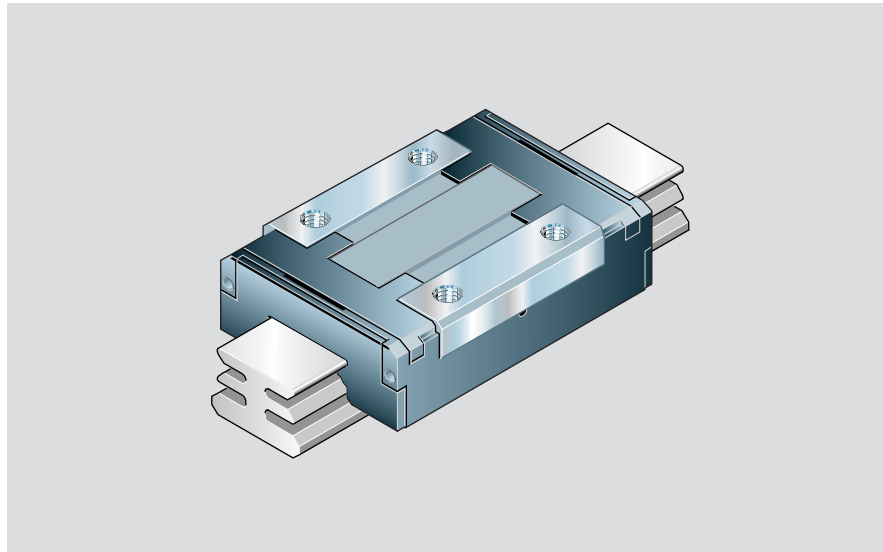

Part numbers for runner blocks

Standard seals: low-friction seals.
Part number: R0442 ... 01 (see table)

Special versions:

Runner blocks are also available:

- with N seals (excellent wiping action)
Sizes 15 and 20 have additional longitudinal seals for full sealing.
Part number: R0442 ... 00 (otherwise as per table)
- without basic lubrication for individual lubrication.
 - sizes 15 and 20 additionally with N seals and longitudinal seals
Part number: R0442 ... 40 (otherwise as per table)
 - with low-friction seals
Part number: R0442 ... 41 (otherwise as per table)

Take frictional drag of the respective seals into account.

See chapter "Technical Data", section "Friction and seals".

Note on dynamic load capacities and moments (see table)

The dynamic load capacities and moments are based on 100,000 m travel. However, a travel of just 50,000 is often taken as a basis.

If this is the case, for comparison purposes:

Multiply values C , M_t and M_L from the table by 1.26.

Size	Accuracy class	Part numbers for runner blocks	
		Clearance	Preload
	9	1	
7	P	–	R0442 712 01
	H	R0442 793 01	R0442 713 01
	N	R0442 794 01	–
9/M3	P	–	R0442 812 01
	H	R0442 893 01	R0442 813 01
	N	R0442 894 01	–
9/M2	P	–	R0442 912 01
	H	R0442 993 01	R0442 913 01
	N	R0442 994 01	–
12	P	–	R0442 212 01
	H	R0442 293 01	R0442 213 01
	N	R0442 294 01	–
15	P	–	R0442 512 01
	H	R0442 593 01	R0442 513 01
	N	R0442 594 01	–
20	P	–	R0442 012 01
	H	R0442 093 01	R0442 013 01
	N	R0442 094 01	–

Ordering example 1:

Runner block size 12,
accuracy class P, preloaded, standard seals
Ordering data: R0442 212 01

Ordering example 2:

Runner block size 7,
accuracy class H, clearance, N seals
Ordering data: R0442 793 00

Ordering example 3:

Runner block size 15,
accuracy class H, preloaded, N seals and
longitudinal seals, no basic lubrication
Ordering data: R0442 513 40

Ordering example 4:

Runner block size 9/M3,
accuracy class N, clearance, standard
seals, no basic lubrication
Ordering data: R0442 894 41

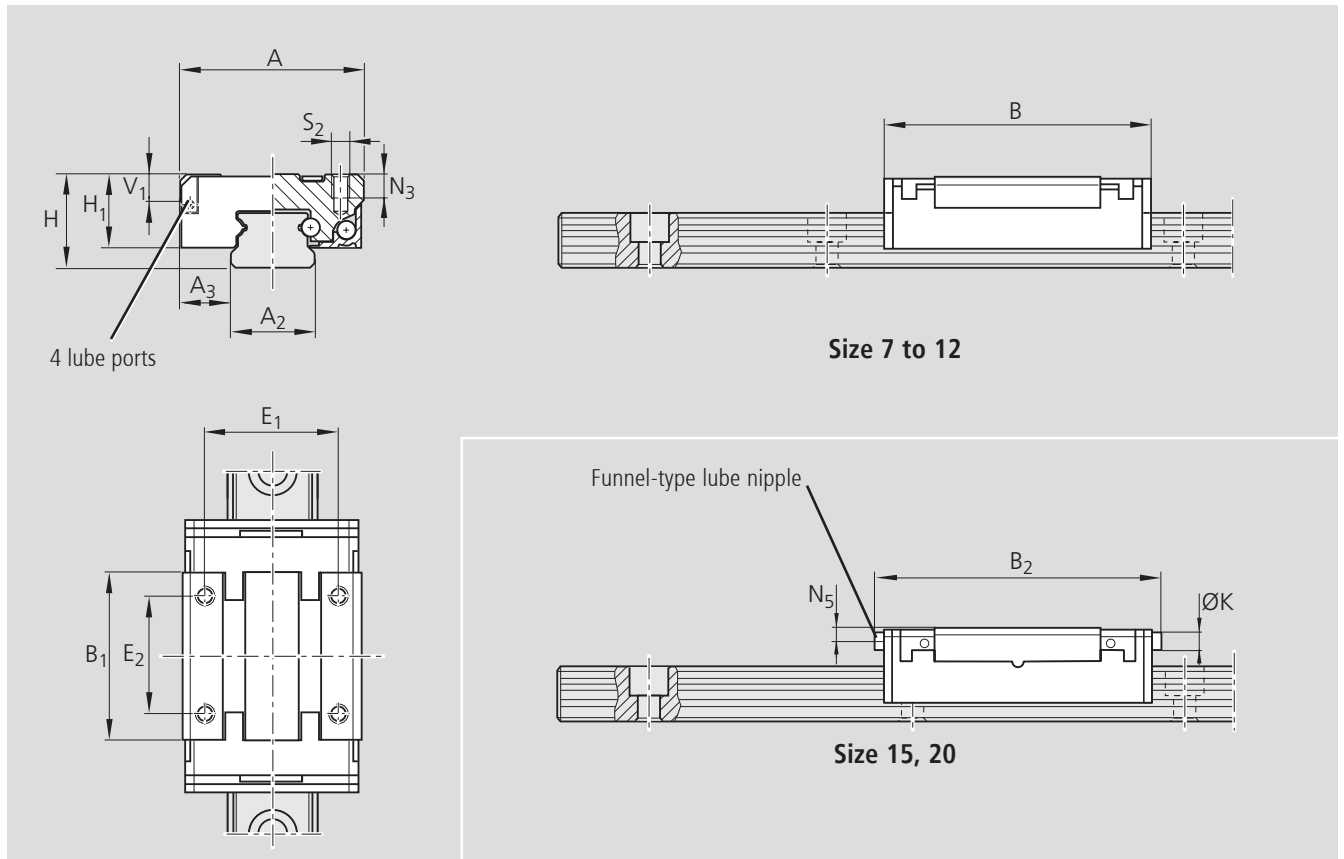

Size	Dimensions [mm]															
	A	A ₂	A ₃	B	B ₁	B ₂	H	H ₁ ¹⁾	H ₁ ²⁾	V ₁	E ₁	E ₂	K	N ₃	N ₅	S ₂
7	17	7	5.0	24.0	14.9	–	8	6.5	–	2.0	12	8	-	2.5	-	M2
9/M3	20	9	5.5	31.0	20.7	–	10	8.0	–	2.8	15	10	-	3.0	-	M3
9/M2	20	9	5.5	31.0	20.7	–	10	8.0	–	2.8	15	13	-	2.5	-	M2
12	27	12	7.5	34.8	21.6	–	13	10.0	–	3.3	20	15	-	3.5	-	M3
15	32	15	8.5	43.0	27.2	46	16	12.0	12.65	4.7	25	20	4	4.0	2.1	M3
20	46	20	13.0	66.0	45.1	69	25	17.5	18.15	7.0	38	38	4	6.0	3.1	M4

1) without longitudinal seal

2) with longitudinal seal

Size	Weight Runner blocks [g]	Load capacities [N]		Moments [Nm]			
		C ¹⁾ dyn.	C ₀ ¹⁾ stat.	M _t ²⁾		M _L ²⁾	
				dyn.	stat.	dyn.	stat.
7	9	860	1400	3.1	5.1	1.9	3.2
9/M3	16	1180	2100	5.4	9.6	3.6	6.4
9/M2	16	1180	2100	5.4	9.6	3.6	6.4
12	33	2310	3470	13.7	20.6	7.9	11.8
15	47	4200	6260	31.2	46.3	18.3	27.0
20	177	7900	12230	81.4	126.0	51.7	80.0

1) Calculated values conforming to DIN 636 Part 2

2) Calculated values (based on C, C₀)

Long Runner Block R0444

All steel parts are made of rust and acid resistant material similar to ISO 683-17 / EN 10088.

Runner blocks are supplied on mandrels.

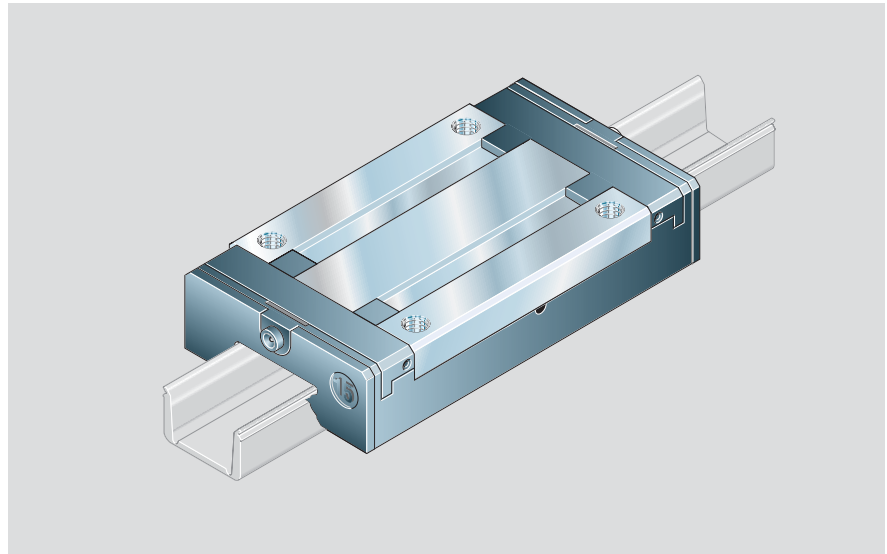

Part numbers for runner blocks

Standard seals: low-friction seals.
Part number: R0444 ... 01 (see table)

Special versions:
Runner blocks are also available:

- with N seals (excellent wiping action)
Sizes 9/M3, 12 and 15 have additional longitudinal seals for full sealing.
Part number: R0444 ... 00 (otherwise as per table)
- without basic lubrication for individual lubrication.
- sizes 9/M3, 12 and 15 additionally with N seals and longitudinal seals
Part number: R0444 ... 40 (otherwise as per table)
- with low-friction seals
Part number: R0444 ... 41 (otherwise as per table)

Take frictional drag of the respective seals into account.

See chapter "Technical Data", section "Friction and seals".

Note on dynamic load capacities and moments (see table)

The dynamic load capacities and moments are based on 100,000 m travel. However, a travel of just 50,000 is often taken as a basis.

If this is the case, for comparison purposes:

Multiply values **C**, **M_t** and **M_L** from the table by 1.26.

Size	Accuracy class	Part numbers for runner blocks	
		Clearance 9	Preload 1
7	P	–	R0444 712 01
	H	R0444 793 01	R0444 713 01
	N	R0444 794 01	–
9/M3	P	–	R0444 812 01
	H	R0444 893 01	R0444 813 01
	N	R0444 894 01	–
12	P	–	R0444 212 01
	H	R0444 293 01	R0444 213 01
	N	R0444 294 01	–
15	P	–	R0444 512 01
	H	R0444 593 01	R0444 513 01
	N	R0444 594 01	–

Ordering example 1:

Runner block size 12, accuracy class P, preloaded, standard seals

Ordering data: R0444 212 01

Ordering example 2:

Runner block size 7, accuracy class H, clearance, N seals

Ordering data: R0444 793 00

Ordering example 3:

Runner block size 15, accuracy class H, preloaded, N seals and longitudinal seals, no basic lubrication

Ordering data: R0444 513 40

Ordering example 4:

Runner block size 9/M3, accuracy class N, clearance, standard seals, no basic lubrication

Ordering data: R0444 894 41

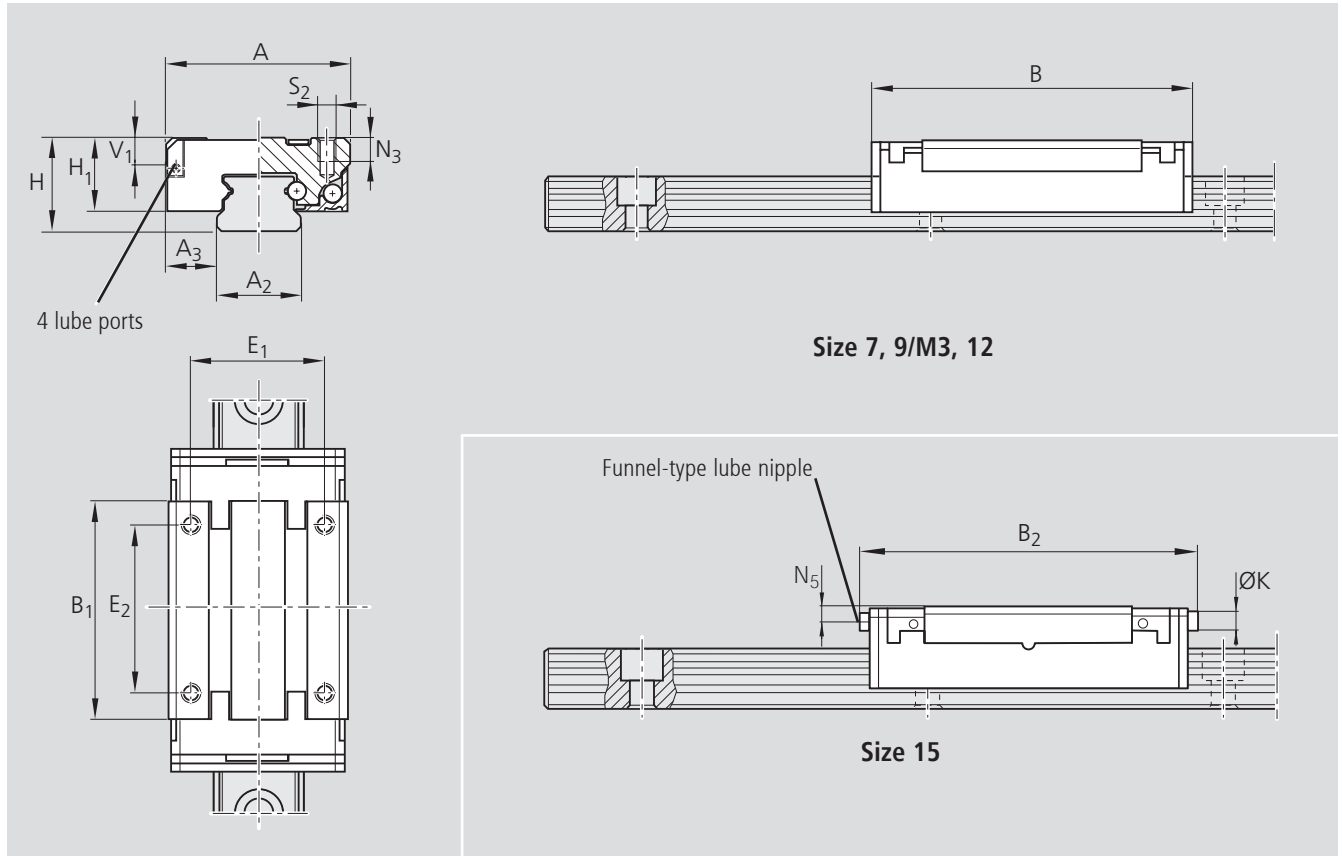

Size	Dimensions [mm]															
	A	A ₂	A ₃	B	B ₁	B ₂	H	H ₁ ¹⁾	H ₁ ²⁾	V ₁	E ₁	E ₂	K	N ₃	N ₅	S ₂
7	17	7	5.0	33.0	24.1	–	8	6.5	–	2.0	12	13	-	2.5	-	M2
9/M3	20	9	5.5	41.4	31.3	–	10	8.0	8.65	2.8	15	16	-	3.0	-	M3
12	27	12	7.5	47.5	34.5	–	13	10.0	10.65	3.3	20	20	-	3.5	-	M3
15	32	15	8.5	60.8	45.0	63.8	16	12.0	12.65	4.7	25	25	4	4.0	2.1	M3

1) without longitudinal seal

2) with longitudinal seal

Size	Weight Runner blocks [g]	Load capacities [N]		Moments [Nm]			
		C ¹⁾ dyn.	C ₀ ¹⁾ stat.	M _t ²⁾		M _L ²⁾	
				dyn.	stat.	dyn.	stat.
7	14	1220	2340	4.5	8.5	4.3	8.3
9/M3	26	1570	3150	7.2	14.5	7.0	14.0
12	51	3240	5630	19.3	33.5	16.8	29.2
15	94	5940	10170	44.0	75.3	39.2	67.1

1) Calculated values conforming to DIN 636 Part 2

2) Calculated values (based on C, C₀)

Standard Guide Rails R0445

for runner blocks R0442 and R0444.
Guide rails are made of rust and acid resistant material similar to ISO 683-17 / EN 10088.

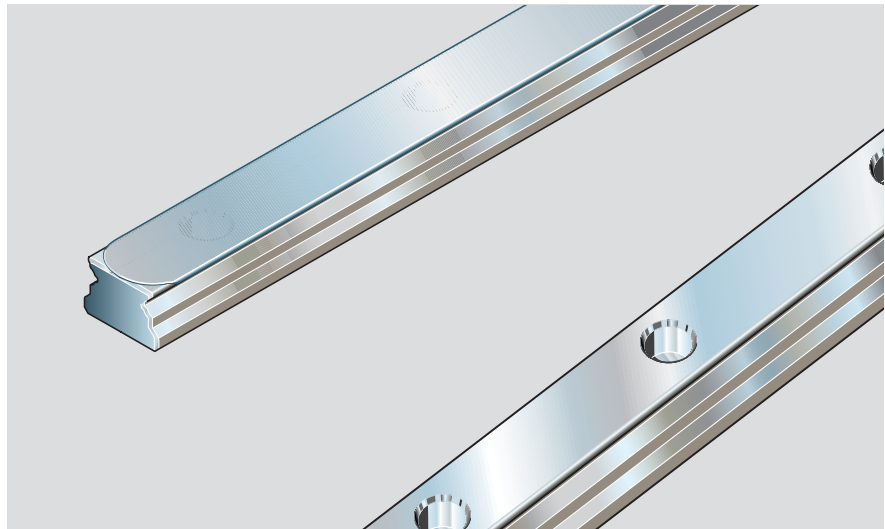

Part numbers for guide rails

Size	Accuracy class	Part numbers for guide rails Part number, Length L [mm]	
		without cover strip	with cover strip
7	P	R0445 702 31,....	—
	H	R0445 703 31,....	—
	N	R0445 704 31,....	—
9/M3	P	R0445 802 31,....	R0445 862 31,....
	H	R0445 803 31,....	R0445 863 31,....
	N	R0445 804 31,....	R0445 864 31,....
9/M2	P	R0445 902 31,....	R0445 962 31,....
	H	R0445 903 31,....	R0445 963 31,....
	N	R0445 904 31,....	R0445 964 31,....
12	P	R0445 202 31,....	R0445 262 31,....
	H	R0445 203 31,....	R0445 263 31,....
	N	R0445 204 31,....	R0445 264 31,....
15	P	R0445 502 31,....	R0445 562 31,....
	H	R0445 503 31,....	R0445 563 31,....
	N	R0445 504 31,....	R0445 564 31,....
20	P	R0445 002 31,....	R0445 062 31,....
	H	R0445 003 31,....	R0445 063 31,....
	N	R0445 004 31,....	R0445 064 31,....

Recommended rail lengths

$$L = n_B \cdot T - 4$$

L = rail length [mm]
T = hole spacing [mm]
 n_B = no. of holes

Dimensions and weights

Guide rail:
 Position tolerance of the mounting holes for
 - rail length up to 500 mm $\oplus \ominus \varnothing 0.3$
 - rail length up to 1000 mm $\oplus \ominus \varnothing$ up to 0.6 increasing in linear proportion

Size	Dimensions [mm]									Weight g/100 mm
	A ₂	H ₂ ¹⁾	N ₆	D	S ₅	T _{1min}	T _{1max}	T	L _{max} ²⁾³⁾	
7	7	4,7	2,2	4,3	2,5	5,0	11,5	15	1000	22
9/M3	9	5,5	2,2	6,0	3,5	6,0	15,5	20	1000	33
9/M2	9	5,5	2,5	4,5	2,5	6,0	16,5	20	1000	33
12	12	7,8	3,0	6,0	3,5	6,0	20,5	25	1000	61
15	15	9,5	4,7	6,0	3,5	6,0	35,5	40	1000	97
20	20	15,0	6,5	9,5	6,0	6,5	53,5	60	1000	211

- 1) Dimensions without cover strip
- 2) For rail lengths longer than L_{max} factory-made mating sections are joined end-to-end.
- 3) For special cases one-piece guide rails up to 2000 mm length possible (please check with factory).

Ordering examples

Example 2 (up to L_{max} with cover strip):

Guide rail size 12 with cover strip, accuracy class P, recommended rail length 771 mm (30 · T, number of holes n_B = 31, T₁ at one end of guide rail = 4.5 mm)

Ordering data:
R0445 262 31,771 mm, T₁ = 4.5 mm

(At the other end of the guide rail T₁ = 16.5 mm for production reasons.)

If no T₁ is specified by the customer, both ends of the guide rail will be identical. The rail lengths were calculated using the formula for recommended rail lengths.

Example 3 (over L_{max}):

Guide rail size 12, accuracy class N, recommended rail length 1271 mm, 2 sections (50 · T, number of holes n_B = 51, T₁ is identical at both ends of the composite guide rail)

Ordering data: R0445 204 32,1271 mm

Number of sections

Example 1 (up to L_{max}):

Guide rail size 12, accuracy class P, recommended rail length 771 mm (30 · T, number of holes n_B = 31, T₁ is identical at both ends of the guide rail)

Ordering data: R0445 202 31,771 mm

Example 4 (one-piece over L_{max}):

Guide rail size 12, accuracy class P, recommended rail length 771 mm (70 · T, number of holes n_B = 71, T₁ is identical at both ends of the guide rail)

Ordering data: R0445 202 31,1771 mm

Wide Runner Blocks R0443

All steel parts are made of rust and acid resistant material similar to ISO 683-17 / EN 10088.

Runner blocks are supplied on mandrels.

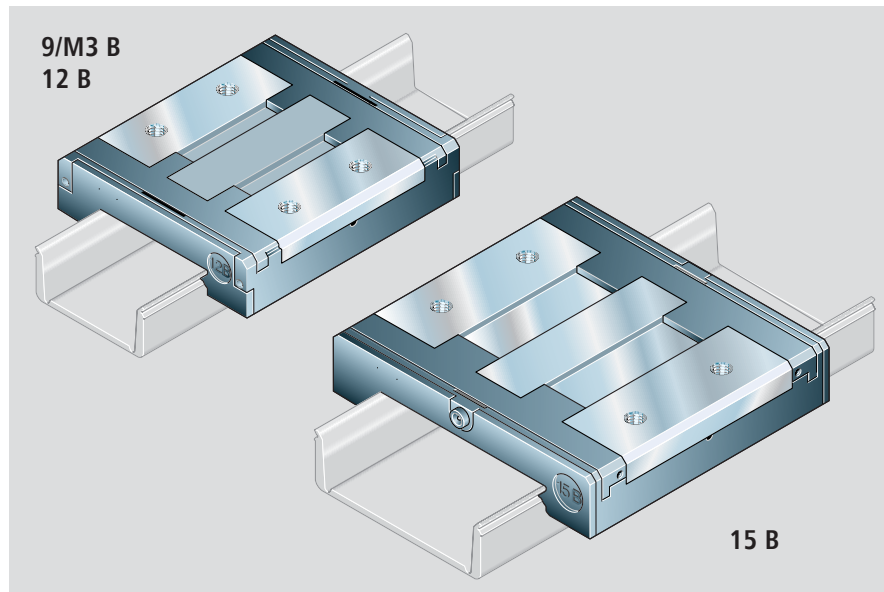

Part numbers for runner blocks

Standard seals: low-friction seals.

Part number: R0443 ... 01 (see table)

Special versions:

Runner blocks are also available:

- with N seals (excellent wiping action) and longitudinal seals for full sealing.
Part number: R0443 ... 00 (otherwise as per table)
- without basic lubrication for individual lubrication.
 - with N seals and longitudinal seals
Part number: R0443 ... 40 (otherwise as per table)
 - with low-friction seals
Part number: R0443 ... 41 (otherwise as per table)

Take frictional drag of the respective seals into account.

See chapter "Technical Data", section "Friction and seals".

Size	Accuracy class	Part numbers for runner blocks	
		Clearance	Preload
	9		
9/M3 B	P	–	0443-812-01
	H	0443-893-01	0443-813-01
	N	0443-894-01	–
12 B	P	–	0443-212-01
	H	0443-293-01	0443-213-01
	N	0443-294-01	–
15 B	P	–	0443-512-01
	H	0443-593-01	0443-513-01
	N	0443-594-01	–

Note on dynamic load capacities and moments (see table)

The dynamic load capacities and moments are based on 100,000 m travel.

However, a travel of just 50,000 is often taken as a basis.

If this is the case, for comparison purposes:

Multiply values C , M_t and M_L from the table by 1.26.

Ordering example 1:

Runner block size 12 B, accuracy class P, preloaded, standard seals

Ordering data: R0443 212 01

Ordering example 2:

Runner block size 12 B, accuracy class H, clearance, N seals

Ordering data: R0443 293 00

Ordering example 3:

Runner block size 15 B, accuracy class H, preloaded, N seals and longitudinal seals, no basic lubrication

Ordering data: R0443 513 40

Ordering example 4:

Runner block size 9/M3 B, accuracy class N, clearance, standard seals, no basic lubrication

Ordering data: R0443 894 41

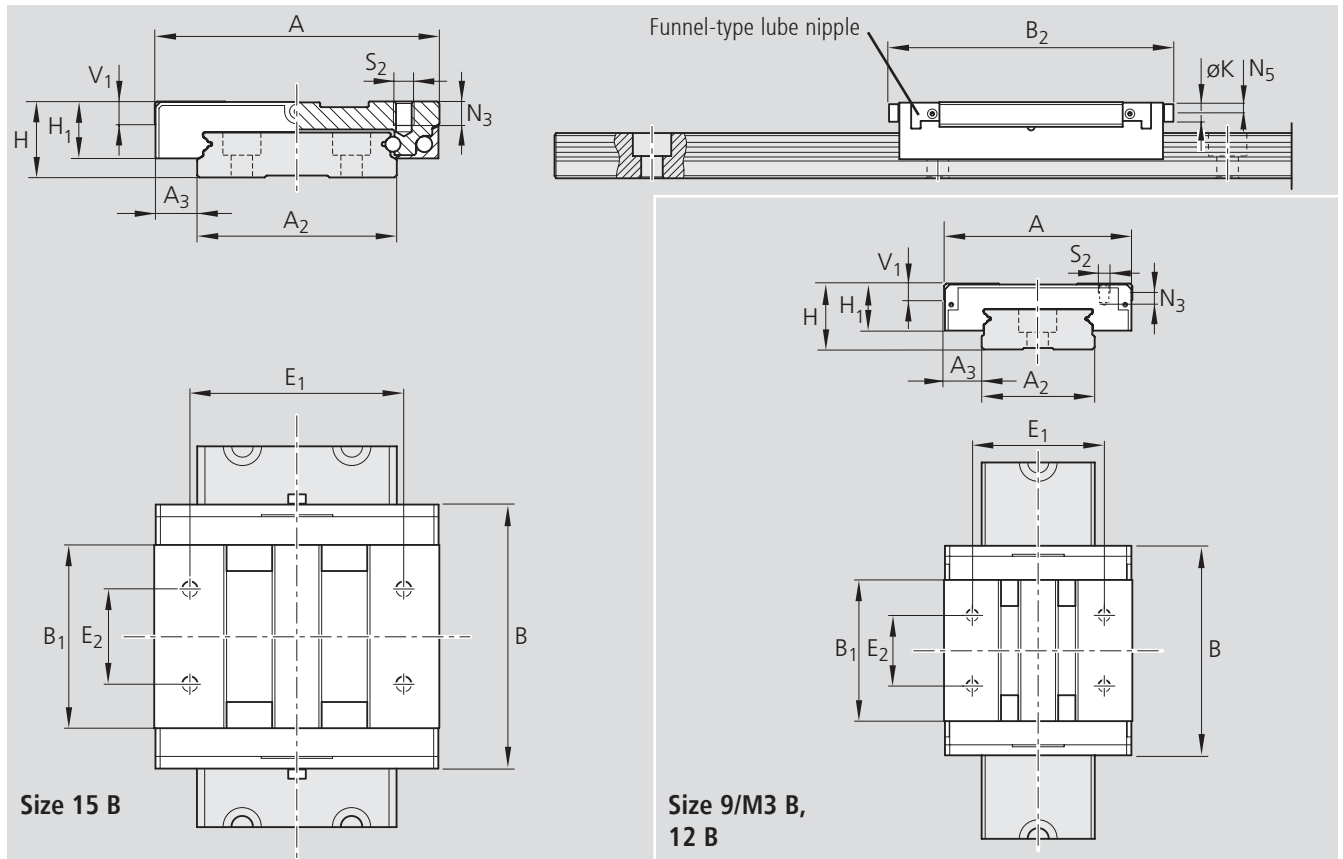

Size	Dimensions [mm]															
	A	A ₂	A ₃	B	B ₁	B ₂	H	H ₁ ¹⁾	H ₁ ²⁾	V ₁	E ₁	E ₂	K	N ₃	N ₅	S ₂
9/M3 B	30	18	6.0	39.0	26.0	–	12	9.0	9.65	2.8	21	12	–	3.2	–	M3
12 B	40	24	8.0	44.5	30.0	–	14	10.0	10.65	3.3	28	15	–	4.0	–	M3
15 B	60	42	9.0	55.5	38.6	58.5	16	12.0	12.65	4.7	45	20	4	4.5	2.1	M4

1) without longitudinal seal

2) with longitudinal seal

Size	Weight Runner blocks [g]	Load capacities [N]		Moments [Nm]			
		C ¹⁾ dyn.	C ₀ ¹⁾ stat.	M _t ²⁾		M _L ²⁾	
				dyn.	stat.	dyn.	stat.
9/M3 B	26	1920	3330	15.9	27.6	7.4	12.9
12 B	51	3200	5340	37.9	63.2	14.3	23.9
15 B	110	5285	8610	107.0	174.0	30.0	49.0

1) Calculated values conforming to DIN 636 Part 2

2) Calculated values (based on C, C₀)

Wide Guide Rails R0455

Mounting hole pattern size 9/M3 B, 12 B:

- single row

Mounting hole pattern size 15 B:

- double row

Guide rails are made of rust and acid resistant material similar to ISO 683-17 / EN 10088.

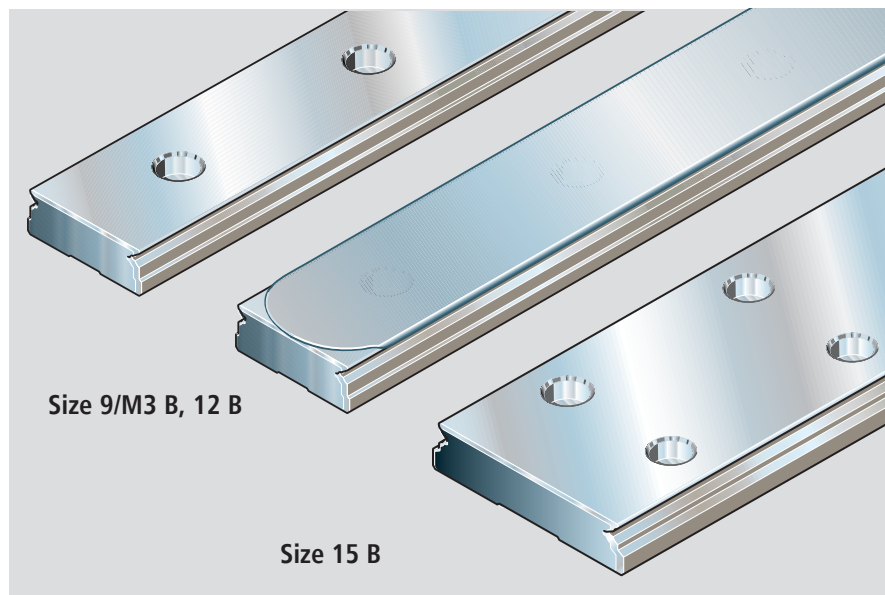

Part numbers

Size	Accuracy class	Part numbers for wide guide rails	
		Part number, Length L [mm] without cover strip	Part number, Length L [mm] with cover strip
9/M3 B	P	R0455 802 31,....	R0455 862 31,....
	H	R0455 803 31,....	R0455 863 31,....
	N	R0455 804 31,....	R0455 864 31,....
12 B	P	R0455 202 31,....	R0455 262 31,....
	H	R0455 203 31,....	R0455 263 31,....
	N	R0455 204 31,....	R0455 264 31,....
15 B	P	R0455 502 31,....	R0455 562 31,....
	H	R0455 503 31,....	R0455 563 31,....
	N	R0455 504 31,....	R0455 564 31,....

Recommended rail lengths

$$L = n_B \cdot T - 4$$

L = rail length [mm]
 T = hole spacing [mm]
 n_B = no. of holes per row

Ordering examples

Example 2 (up to L_{max} with cover strip):

Guide rail size 9/M3 B, accuracy class H, recommended rail length 926 mm (30 · T, number of holes n_B = 31, T₁ at one end of guide rail = 4.5 mm)

Ordering data:

R0455 863 31, 926 mm, T₁ = 4.5 mm

(At the other end of the guide rail T₁ = 21.5 mm for production reasons.)

☞ If no T₁ is specified by the customer, both ends of the guide rail will be identical.

The rail lengths were calculated using the formula for recommended rail lengths.

Example 3 (over L_{max}):

Guide rail size 15 B, accuracy class N, recommended rail length 1436 mm, 2 sections (35 · T, number of holes n_B = 36 per row, T₁ is identical at both ends of the composite guide rail)

Ordering data: R0455 504 32, 1436 mm



Example 1 (up to L_{max}):

Guide rail size 12 B, accuracy class P, recommended rail length 836 mm (20 · T, number of holes n_B = 21, T₁ is identical at both ends of the guide rail)

Ordering data: R0455 202 31, 836 mm

Example 4 (one-piece over L_{max}):

Guide rail size 12 B, accuracy class P, recommended rail length 1636 mm (40 · T, number of holes n_B = 41, T₁ is identical at both ends of the guide rail)

Ordering data: R0455 202 31, 1636 mm

Dimensions and weights

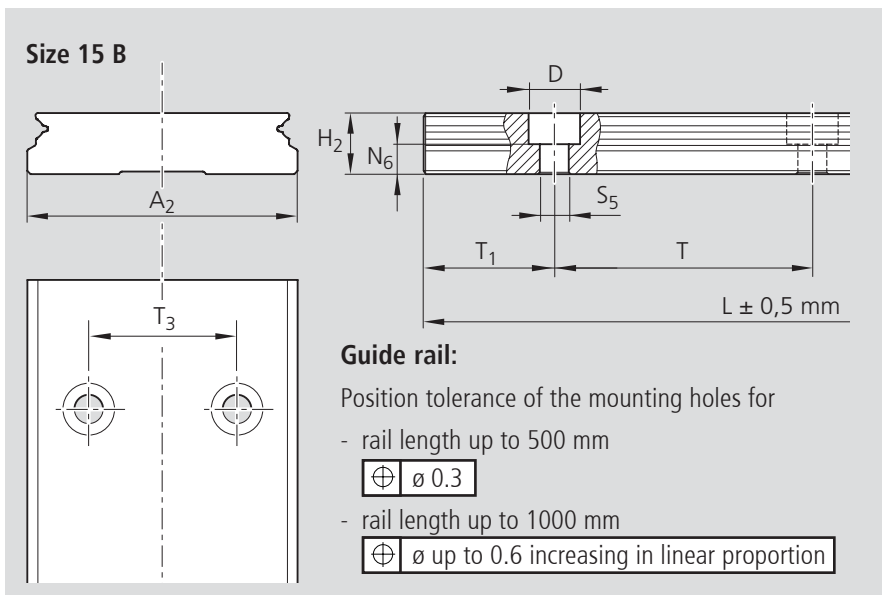
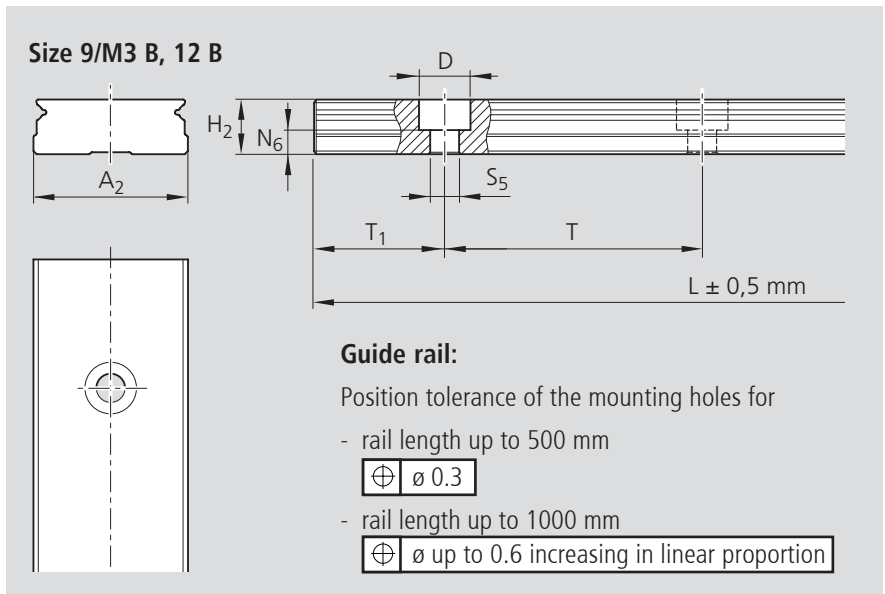

Size	Dimensions [mm]										Weight g/100 mm
	A ₂	H ₂ ¹⁾	N ₆	D	S ₅	T _{1min}	T _{1max}	T	T ₃	L _{max} ²⁾³⁾	
9/M3 B	18	7.5	2.7	6.0	3.5	4.5	25.5	30	–	1000	92
12 B	24	8.5	3.7	8.0	4.5	5.5	34.5	40	–	1000	145
15 B	42	9.5	4.7	8.0	4.5	5.5	34.5	40	23	1000	286

¹⁾ Dimensions without cover strip

²⁾ For rail lengths longer than L_{max} factory-made mating sections are joined end-to-end.

³⁾ For special cases one-piece guide rails up to 2000 mm length possible (please check with factory).

Start-up and Maintenance

Start-up

Initial lubrication of runner blocks is necessary before Miniature Ball Rail Systems are put into service!

Runner blocks are available:

- prelubricated with a lithium soap grease, consistency class NLGI 00, Dynalub 520
- without initial lubrication for individual grease or oil lubrication.

Initial lubrication with grease

We recommend a grease lubricant to DIN 51825, class KP00K.

A grease of this type, Dynalub 520, is available in the following versions:

- Maintenance kit with 5 ml dispensing unit Part no. R0419 090 01
- 400 g cartridge for use in grease guns Part no. R3416 043 00

Note:

- Grease the runner block as per table.
- Move the runner block toward the lube port used to distribute the grease evenly.
- Make sure there is a visible film of grease on the guide rail.

Initial lubrication with oil

We recommend the use of oils meeting the minimum requirements for CLP lubricant oils (DIN 51517, Part 3) or HLP hydraulic oils (DIN 51524, Part 2). The oil must have a viscosity of 100 mm²/s at 40°C.

- Observe the manufacturer's instructions.
- It is essential to check that the lubricant will reach all rolling bearings in the installed condition (orientation).
- Apply oil until excess emerges.

 Add the entire oil quantity in one go!

Maintenance

The maintenance intervals depend on the application and the ambient conditions.

Under normal conditions no in-service lubrication is required.

Cleaning

Dirt can settle and encrust on the guide rails, especially when these are not enclosed.

- Always run a cleaning cycle before shutting down the machine.

This dirt must be removed to protect the seals.

In-service lubrication

Initial lubrication (long-term lubrication) is sufficient for 5,000 km travel where:

- $F < 0.1 \text{ C}$
- $V_m = 0.65 \text{ m/s}$
- $> 90 \text{ mm stroke}$
- low-friction seals
- For in-service lubrication with grease or oil, follow instructions as for initial lubrication.

Ambient conditions include: swarf, metallic and other abrasion, solvents and temperature.

Types of load include: vibrations, impacts and tilting.

 The service conditions are unknown to the manufacturer. Users can only determine the in-service lubrication intervals with certainty by conducting in-house tests or by careful observation.

 The in-service lubrication intervals depend on ambient conditions, loading and type of load!

 Do not allow guide rails or runner blocks to come into contact with water-based coolants!

Service kit

A **special syringe** is used to apply lubricant to the **lube ports** at the sides or end faces of the runner block (part number: 0419-090-01).

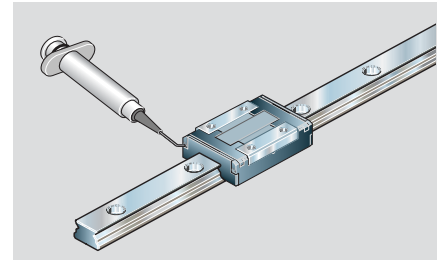
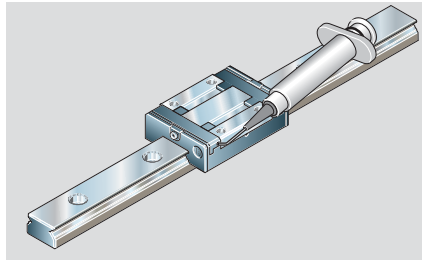

If the **funnel-type lube nipples** on the runner block end faces are preferred, use a **grease gun** instead.

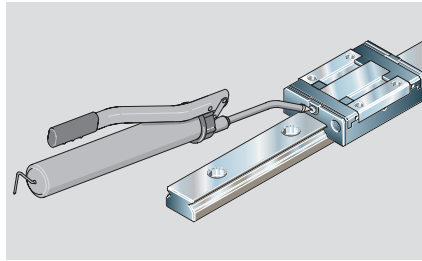

Short stroke (stroke < 2 runner block lengths)

See "Lubrication quantities and methods" for the method to be used for short stroke applications.

For strokes < 0.5 runner block length, slide the runner block over 2 complete runner block lengths per lubrication cycle. If this is not possible, please consult us.

Lubrication Quantities and Methods

The lubrication method depends on the size, as given in the table:

Size	Lubrication by	
	Method 1	Method 2
Standard runner block R0442		
7	✓	
9/M2	✓	
9/M3	✓	
12	✓	
15		✓
20		✓
Wide runner block R0443		
9/M3 wide	✓	
12 wide	✓	
15 wide		✓
Long runner block R0444		
7	✓	
9/M3	✓	
12	✓	
15		✓

Method 1

Apply lubricant through the lube ports on the end face.

Size	Initial lubrication with grease	
	Partial amount per side (L/R) [cm ³]	Total amount (L+R) [cm ³]
Standard runner block R0442		
7	0.025	0.05
9/M3	0.030	0.06
9/M2	0.030	0.06
12	0.075	0.15
Wide runner block R0443		
9/M3 B	0.040	0.08
12 B	0.075	0.15
Long runner block R0444		
7	0.040	0.08
9/M3	0.045	0.09
12	0.120	0.24

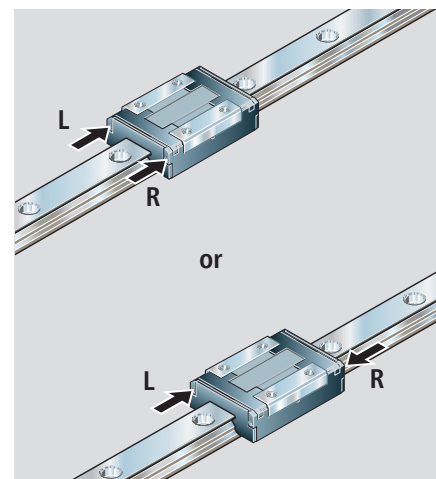

For **short stroke** applications, apply the partial amount per side as given in the table to each end-face lube port.

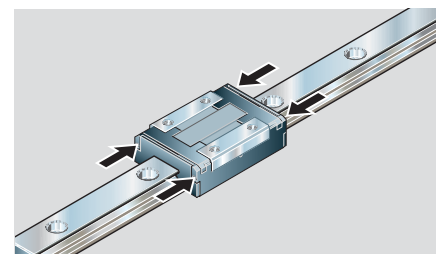

Method 2

Apply lubricant through the lube ports at the sides or the lube nipples on the end face.

Size	Initial lubrication with grease	
	Partial amount per side (L/R) [cm ³]	Total amount via end face [cm ³]
Standard runner block R0442		
15	0.06	0.12
20	0.09	0.18
Wide runner block R0443		
15 B	0.09	0.18
Long runner block R0444		
15	0.10	0.20

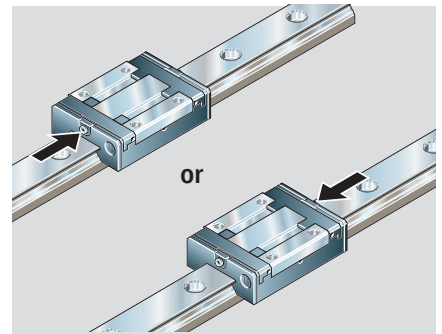
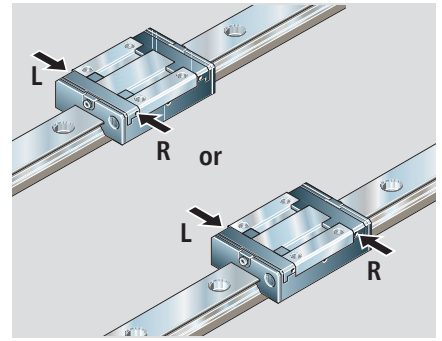

For **short stroke** applications, apply either the total amount as per table to each end-face lube nipple, or the partial amount per side as given in the table to each side lube port.

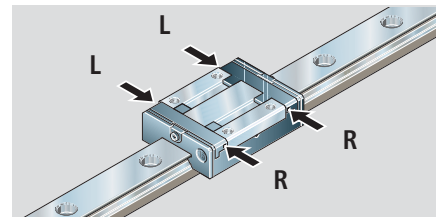
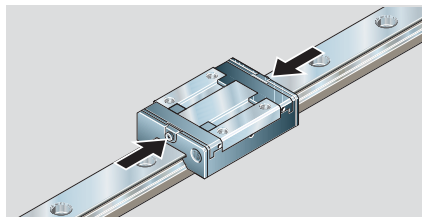

Bosch Rexroth Corporation
Linear Motion and
Assembly Technologies
14001 South Lakes Drive
Charlotte, NC 28273
Telephone (800) 438-5983
Facsimile (704) 583-0523
www.boschrexroth-us.com

Bosch Rexroth Corporation
Corporate Headquarters
5150 Prairie Stone Parkway
Hoffman Estates, IL 60192-3707
Telephone (847) 645-3600
Facsimile (847) 645-6201

Bosch Rexroth Corporation
Industrial Hydraulics
2315 City Line Road
Bethlehem, PA 18017-2131
Telephone (610) 694-8300
Facsimile (610) 694-8467

Bosch Rexroth Corporation
Electric Drives and Controls
5150 Prairie Stone Parkway
Hoffman Estates, IL 60192-3707
Telephone (847) 645-3600
Facsimile (847) 645-6201

Bosch Rexroth Corporation
Pneumatics
1953 Mercer Road
Lexington, KY 40511-1021
Telephone (859) 254-8031
Facsimile (859) 281-3491

Bosch Rexroth Corporation
Mobile Hydraulics
1700 Old Mansfield Road
Wooster, OH 44691-0394
Telephone (330) 263-3300
Facsimile (330) 263-3333