

NSK Technical Journal

Motion & Control

No. 18 August 2005

Special Issue of Products for Machinery



ISSN1342-3630

NSK

MOTION & CONTROL No. 18

NSK Technical Journal

Printed and Published: August 2005

ISSN1342-3630

Publisher: NSK Ltd., Ohsaki, Shinagawa, Tokyo, JAPAN

Public Relations Department

TEL +81-3-3779-7051

FAX +81-3-3779-7431

Editor: Hisashi MACHIDA

Managing Editor: Masami EISHIMA

Design, Typesetting & Printing: Fuji Ad. Systems Corp.

© NSK Ltd.

The contents of this journal are the copyright of NSK Ltd.

Cover photos:

Products for Machinery

Motion & Control

No. 18

August 2005

Contents

Special Articles

- NSK's General Industrial Products and Technologies ————— *Hisashi Machida* 1
- Technology of Highly Reliable Bearings for Wind Turbine Gearboxes
————— *Tetsuo Watanabe* 2
- Bearing Technologies for Centrifugal Pumps
————— *Hiroshi Ishiguro, Manabu Yamada* 9
- Trends of Bearing Technology in Iron and Steel Industries — *Takamasa Ohira* 14
- Automatic Grease Replenishing System for Machine Tool Main Spindles
—Fine Lub II ————— *Saburo Azumi* 22
- S3 Ball Screws: Super Low-Noise Ball Screws for Automation Equipment
————— *Toshiharu Kajita, Eiji Hayashi* 28
- Development of New Series of Megatorque Motor™ Series for
High Speed and Precise Positioning
———— *Yoichi Igarashi, Hirohide Konishi, Seiichi Kobayashi* 34

New Products

- Long Life Roll Neck Bearings for Steel Rolling Mills
—WTF™ Bearings ————— 42
- Sensor Bearings for General Industrial Machinery ————— 44
- Long-Term Maintenance-Free Ball Bearings for
Railway Traction Motors ————— 46
- Ultra-Precision Bearings for Precision Machine Tools
—Robust™ P2X Series ————— 48
- Miniature Monocarrier™ MCM02 ————— 50
- New Generation of NSK Linear Guides
Miniature PU Series/PE Series ————— 52

NSK's General Industrial Products and Technologies

Hisashi Machida
Director, Executive Vice President

NSK has been growing with the development of various industries since its founding in 1916.

Starting with rolling bearings for equipment used in heavy industries such as steel mills during Japan's early post World War II period of rapid recovery, we developed state-of-the-art bearings for washing machines and refrigerators during the 1950s, and for vacuum cleaners, passenger cars, the Shinkansen bullet trains, etc. in the 1960s.

In the 1970s, NSK developed bearings for air conditioners, NC lathes, and machining centers. This was also when we started bearing production at sites outside of Japan.

The next decade witnessed the propagation of videocassette recorders, personal computers, megabyte-capacity semiconductors, and a trend towards greater automation in the manufacturing sector. Environmental issues, advanced robotics, wind turbine gearboxes, and more were highlighted in the 1990s. Throughout these periods, NSK continually developed various types of bearings that met customer needs.

The scope of NSK business has been expanded by adding high accuracy positioning technologies and electronic control technologies to our core technologies, which have been acquired over the years during the development and production of bearings.

NSK's precision machinery and parts began with ball screws in the early 1960s. We expanded to include highly accurate applications such as linear guides and XY stages. Our next accomplishment was with mechatronics products that included direct drive motors and robot modules. In recent years, our product range grew to include system products, such as proximity aligners. Consequently, the quality and volume of NSK products related to precision machinery and parts have grown substantially. Thus, NSK has solidified its position as one of the leading global companies among machine parts manufacturers, and has established its base as a total engineering enterprise.

In this special edition, some of the recent technological achievements and new products are introduced from among NSK products for general industries. Societal changes of the 21st century will occur at a much faster pace than ever before. NSK will respond accordingly with high value-added products based on our four original core technologies: material, lubrication, numerical simulation, and mechatronics. We will further ascertain market trends, and work to fully understand the precise needs of our customers. NSK will continue to strengthen its core technologies, and aggressively promote the establishment of platform of technologies, which are the basis for product design and development.

NSK is also strengthening its global technology system by establishing technology centers to better respond to the needs of our customers with global operations. Technology centers have been expanded to include three in Europe, two in the Americas, and three in Asia. NSK intends to further contribute to society on a whole by developing products for the next generation that will continue to provide the nucleus of *Motion & Control*.



Hisashi Machida

Technology of Highly Reliable Bearings for Wind Turbine Gearboxes

Tetsuo Watanabe
Corporate Research and Development Center

ABSTRACT

Wind power generation is widely recognized as a growing industry for renewable sources of energy. Since the late 1980s, NSK has been supplying all types of bearings used in wind turbines as an all-round bearing manufacturer. In recent years, bearing reliability has become much more critical with the rapidly increasing size of wind turbines. This article describes features of bearings for wind turbine gearboxes and provides details regarding bearing selection with a focus on the speed-increasing gearbox, which is commonly used in a wind turbine with an induction generator. In addition, we will discuss the NSK technologies that have contributed to the improvement of bearing reliability in wind turbine applications.

1. Introduction

In order to reduce green house gases linked to global warming, there is a growing interest in renewable sources of power in all countries. Among them, the market for wind power generation is expanding from Europe to the rest of the world¹⁾ (Fig. 1), and is gaining public attention as a new growth industry.

Since the late 1980s, NSK has been supplying all types of bearings used in wind turbines, which require high reliability and economical efficiency in various types of wind turbines. In this article, we will introduce the features of wind turbine bearings, and focus on the speed-increasing gearbox of induction generators, which are the mainstream generator used in wind turbines that require the highest levels of bearing reliability.

2. Trends of Speed-Increasing Gearbox Mechanisms and Related Bearings

Bearings in wind turbine gearboxes must meet one of the most stringent requirements of reliability; a single wind turbine failure lowers output capacity and requires tremendous expenditures to repair and replace parts. This fact was highlighted by speed-increasing gearbox failures²⁾ that occurred throughout the U.S. during the 80s and 90s. The American Gear Manufacturers Association (AGMA) learned many lessons from these incidents, and developed guidelines, which were completed recently, for speed-increasing gearboxes of wind turbines.³⁾ In their guidelines, the selection of bearings is an important item. Here, we will introduce the structure of a speed-increasing gearbox and discuss the application of bearings involved.

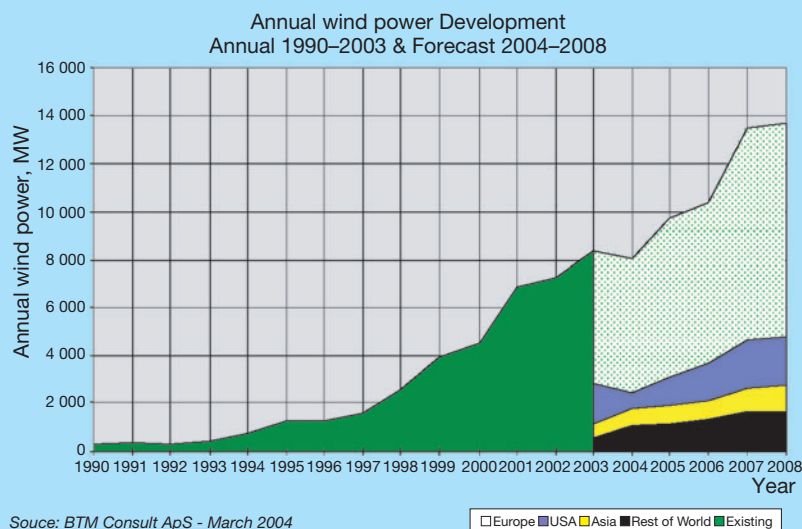

Fig. 1 Annual Wind Power Development

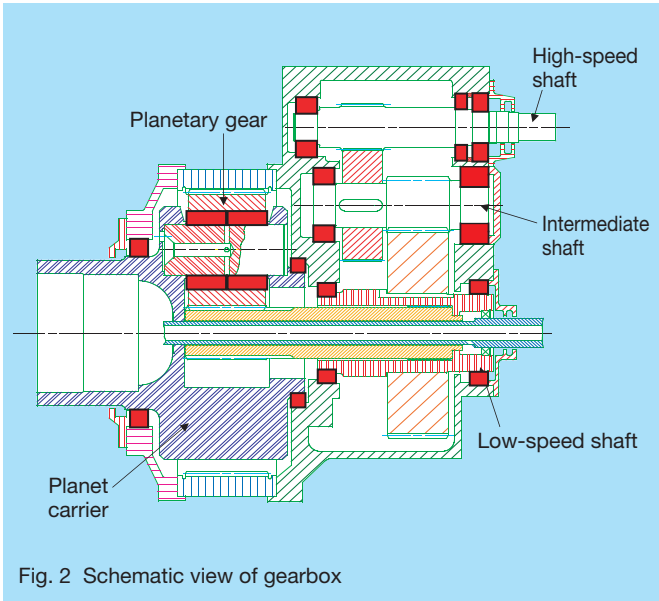

Fig. 2 Schematic view of gearbox

The wind turns the rotor blades, which spin a rotor shaft. A speed-increasing gearbox connects the rotor shaft to a high-speed shaft and increases rotational speeds from about 10 to 30 rpm to about 1 500 to 1 800 rpm, which is the rotational speed required by most induction generators. The speed-increasing gearbox (Fig. 2) is a three-stage gearbox, consisting of a first-stage planetary gear, and second- and third-stage helical gears. Torque input from the rotor shaft drives the planet carrier, which transmits torque through a sun gear and outputs to a second-stage helical gear. Table 1 lists the various types of bearings that are used in a gearbox and bearing location.

Each shaft in the gearbox is supported by two or three bearings, which use either an oil-splash or circulating-oil lubrication delivery system. Gear oil, or a VG320 equivalent, is commonly used. In the planetary gear, high-speed revolutions create centrifugal forces that make it difficult to maintain sufficient oil in the bearing raceways.

Table 1 Types of bearings for gearbox components

Application	Bearing type	Remarks
Planet carrier	FCCRB, SRB, TRB	
Planetary gear	FCCRB, CRB, SRB	FCCRB (No outer ring)
Low-speed shaft	Free end	SRB, FCCRB, CRB
	Fixed end	FCCRB, TRB, SRB
Intermediate shaft	Free end	CRB, SRB
	Fixed end	TRB, SRB, CRB+4PCBB
High-speed shaft	Free end	CRB, SRB
	Fixed end	TRB, SRB, CRB+4PCBB, CRB+TRB

FCCRB: Full complement cylindrical roller bearing
 CRB: Cylindrical roller bearing
 SRB: Spherical roller bearing
 TRB: Tapered roller bearing
 4PCBB: Four-point contact ball bearing

Therefore, a lubricant entry port in the inner ring accumulates lubricant as it rotates and is submerged in the gear oil. The port “scoops” the oil and delivers lubricant to the fitting surface of the bearing.

Recently, input torque and speed ratio have increased with the larger scale of wind turbines. Upon investigating the relation between gearbox bearing size and wind turbine capacity (Fig. 3), we learned that carrier bearings were larger, but overall bearing size remained the same for other wind turbine components. We also looked at the relation between wind turbine capacity and bearing load ratio (P/C) (Fig. 4). We found that high-load capacity bearings were required for the planetary gear. Therefore, the outer ring of some planetary gear bearings was eliminated and the bore surface of the gear is used as an outer ring raceway as a means of increasing bearing capacity and roller diameter to the greatest degree possible.

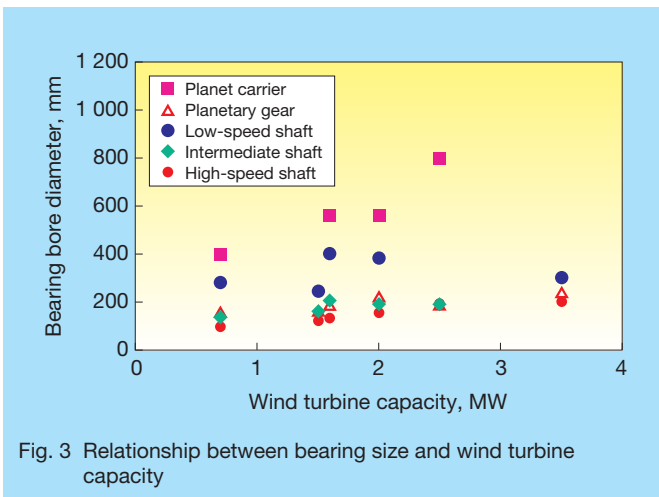

Fig. 3 Relationship between bearing size and wind turbine capacity

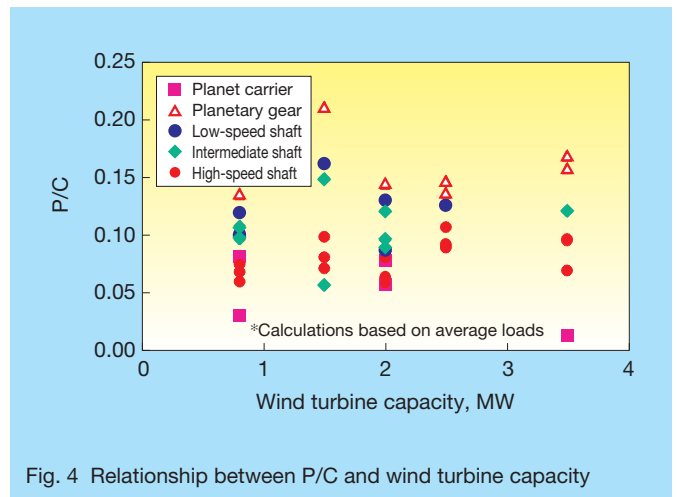

Fig. 4 Relationship between P/C and wind turbine capacity

3. Reliability Technology

3.1 Life

3.1.1 ABLÉ Forecaster

In the process designing a bearing, one criterion used to determine whether a bearing specification can satisfy operating conditions or not conclusively, is bearing fatigue life. NSK developed a new life theory (see below) that factors in fatigue limit load (P_u), lubricating conditions (k), and lubricant contamination (a_c) with the revision of ISO in 2000.

$$L_{able} = a_1 a_{NSK} L_{10} \dots \dots \dots (1)$$

$$a_{NSK} \propto f \left[\frac{P - P_u}{C} \cdot \frac{1}{a_c} \cdot a_L \right] \dots \dots \dots (2)$$

- a_c : Contamination factor
- a_L : Lubrication factor (function of viscosity ratio k)
- P : Bearing load
- P_u : Fatigue limit load
- C : Basic dynamic load rating

NSK's new Advanced Bearing Life Equation (ABLE) Forecaster⁴ (<http://www2.jp.nsk.com/BearingGuide/html/bearing.html>) provides users with a more accurate bearing life calculation tool to assist them in selecting the right bearing for a given application.

3.1.2 BRAIN and STIFF (analysis)

Bearings used in wind turbine speed-increasing gearboxes are subjected to various complex loads such as bending load and tilt moment. Such operating conditions require an analysis of load sharing between the rolling elements, and an analysis of contact surface pressure of each rolling element in consideration of internal clearances. NSK's numerical simulation programs for tribology, numerical analysis, and rolling bearing systems analysis have been bundled into a software suite called BRAIN (Bearing Analysis in NSK).

BRAIN incorporates PACS and STIFF. PACS is a motion analysis program group that provides details for bearing-related friction by bearing type. STIFF, which includes a subroutine of PACS, is a deformation analysis program for shafts and shaft systems.⁵

STIFF is also used to analyze bearings, the bearing periphery, and for treating a bearing as a non-linear spring element. We used STIFF to achieve greater accuracy of complicated analyses (Fig. 5 & 6) of the speed-increasing gearbox where many gears are engaging and their reaction forces affect each shaft mutually.

NSK performs life calculations with ABLÉ Forecaster that include fatigue limit load, lubricating conditions, and contamination level of the lubricant. STIFF is then used to calculate life based on bearing internal clearance or misalignment. Consequently, European customers require that life calculations include both of these two methods.

Wind turbines also require bin-by-bin life calculations.

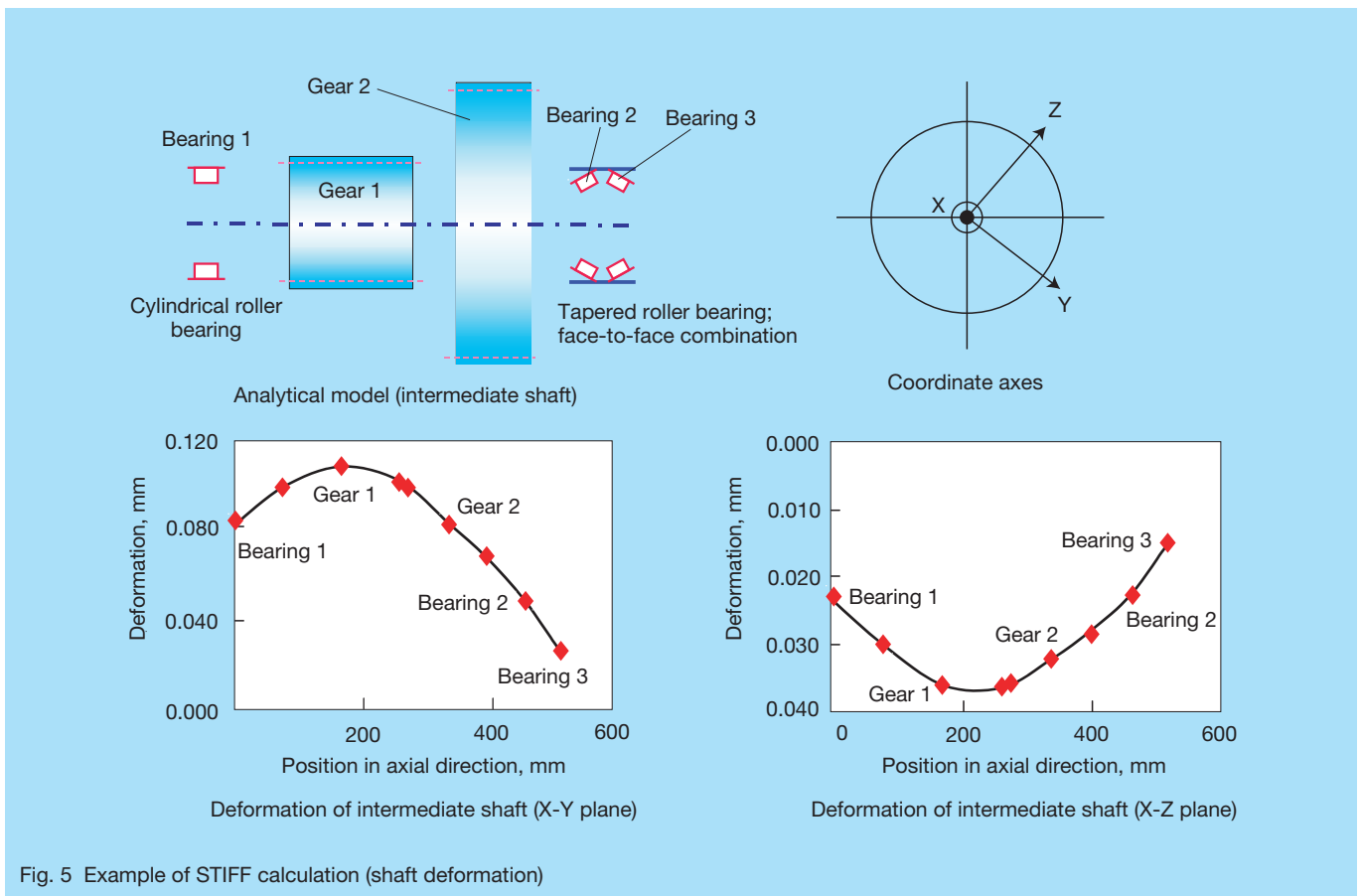

Fig. 5 Example of STIFF calculation (shaft deformation)

This statistical method calculates the total life value by calculating life of each bin, where distribution of appearance frequency of wind speed (torque) (Fig. 7) is classified by the width (bin) of several dozen to several hundreds.

Wind-induced loads depend on accurately forecasting the wind, which is difficult to predict in some parts of the world, such as Japan. However the degree of accuracy depends on several factors including how far into the future a prediction extends. Bearing life calculations are also based on wind-induced loads, which help to ensure higher bearing reliability.

3.1.3 STF and HTF Long-Life Bearing Material

Speed-increasing gearbox bearings are normally exposed to high viscosity gear oil that is used in the gearbox. This creates a harsh environment where bearings may be exposed to wear particles from the gears, and to lubricant-starved conditions due to higher viscosity at the time of initial operations under low-temperature conditions.

If wind turbine bearings cannot satisfy the required life, then NSK's Super-TF (STF) or Hi-TF (HTF)⁷⁾ bearing steels can be used. STF and HTF material provide bearings with superior indentation resistance. As previously described, speed-increasing gearbox bearings, including planetary gear bearings and high-speed shaft bearings, are subjected to low speeds, high loads, and high

viscosity gear oil contaminated with wear particles.

STF and HTF bearing steels mitigate stress concentrations initiated at a debris dent on a bearing surface by optimizing the amount of residual austenite for enhanced life under contaminated lubricant conditions (Fig. 8). The recent completion of the Standard for Design and Specification of Gearboxes for Wind Turbines, published by AGMA, have set standards for lubricant cleanliness in wind turbine components. STF and HTF bearings operated under such clean conditions provide even longer life by as much as 1.5 times to twice that of general bearing steel.

3.2 Maximum contact surface pressure

The contact pressure formed at a line contact between the rollers and raceway surface is not uniform. If the bearing takes moment load, or is misaligned, the load distribution will vary. The AGMA standard stipulates the values of maximum contact pressure for each gearbox component (Table 2) based on empirical data of past component failures.

NSK calculates rolling element load and its maximum contact surface pressure for each gearbox component as prescribed by analytical software (STIFF). Furthermore, bearing specifications are determined by incorporating contact surface pressure distribution and actual usage records.

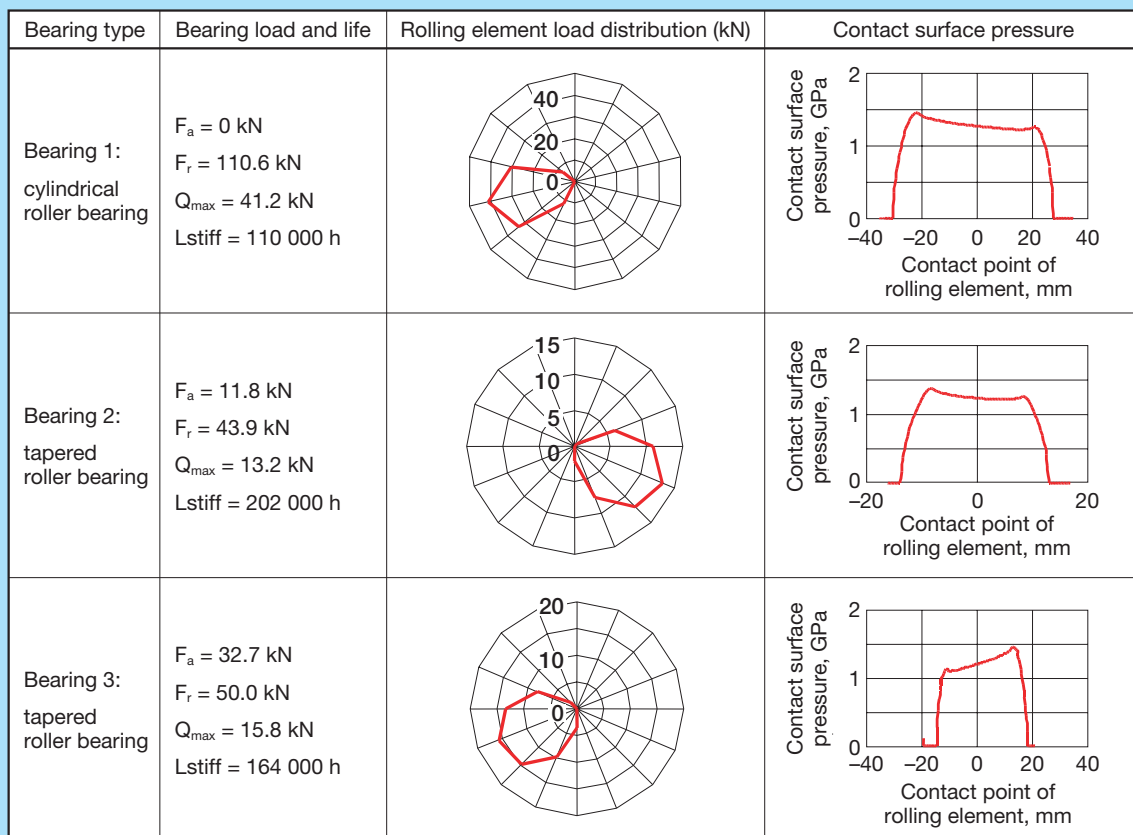

Fig. 6 Example of STIFF calculation (load distribution and contact surface pressure)

Table 2 Maximum contact surface pressures of bearings for Gearbox components

Gearbox component	Maximum contact surface pressure GPa
Planet carrier	N/A
Planetary gear	1.45
Rotor shaft	1.65
Intermediate shaft	1.65
High-speed shaft	1.30

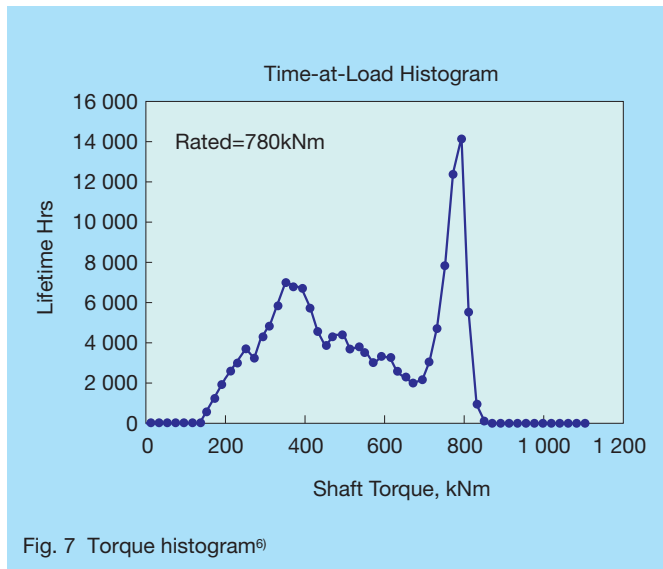

Fig. 7 Torque histogram⁶⁾

3.3 Contact between rib and roller end

Helical gears are primarily used in speed-increasing gearboxes as a measure against noise. When these gears engage, they generate an axial load on the tapered roller bearings. Care must be taken to restrict heat generation at the contact points of rib and roller ends since axial force is generated by the contact angle of the tapered roller bearings under pure radial load conditions.

As the bearing rotates, sliding friction between the inner ring rib and roller ends generates heat, which can lead to bearing failure and seizure of the component. The amount of heat generated depends on the contact surface pressure (P) and the sliding speed (V) of the rollers. Using this PV value, NSK determined whether axial load can be allowed or not for the bearings. In some cases, NJ-type cylindrical roller bearings are used on the fixed end of a shaft for their ability to bear slight axial loads between the roller ends and the inner ring rib on one side. It is also possible to verify the amount of heat generated in tapered roller bearings, as well as NJ-type cylindrical roller bearings. Using the following equation, permissible axial load can be verified. In the bearings, NSK mitigates the contact surface pressure by implementing crowning on the roller ends.

$$C_A = 9.8f \left\{ \frac{490(k \cdot d)^2}{n+1000} - 0.000135 \times (k \cdot d)^{3.4} \right\} \dots \dots \dots (3)$$

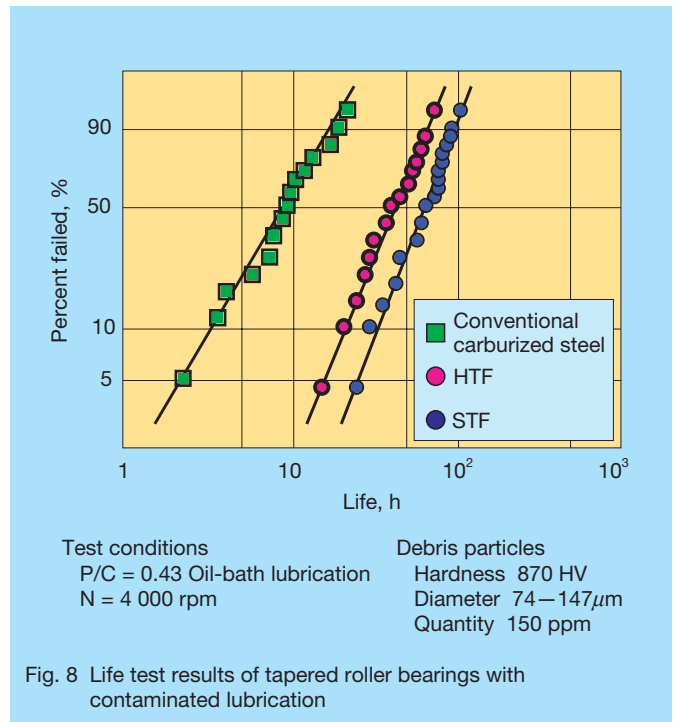

Fig. 8 Life test results of tapered roller bearings with contaminated lubrication

(Under oil lubrication)

- C_A : Permissible axial load (N)
- f : Load factor (Continuous load=1)
- d : Nominal bearing bore diameter (mm)
- n : Bearing rotating speed (rpm)
- k : Dimensional factor
 - Diameter series 2: 0.75
 - Diameter series 3: 1.0
 - Diameter series 4: 1.2

3.4 Cage design

In order to increase the load rating of roller bearings confined to a limited space, roller diameter, roller length, and the number of rollers are maximized to the greatest extent possible. This means that the cage bar and ring dimensions are configured into a low-profile package. The larger rollers have increased mass, which places additional load stresses on the cage. We investigated ways of improving cage strength while maintaining balanced rigidity between the cage bar and ring (Fig. 9).

NSK adopted a newly developed EM cage⁸⁾ for cylindrical roller bearings in wind turbines (Fig. 10) as standard specification. The EM cage offers greater durability and is much improved over conventional cages because of its improved strength. In addition, by adopting roller guides and a spherical shape for the roller contact surface, cage wear is further reduced.

Although processing of a one-piece cage is difficult, NSK was able to develop a proprietary method that ensures superior strength of the cage and enables mass production in large quantities. These achievements significantly contribute to ensuring reliability of wind turbine bearings.

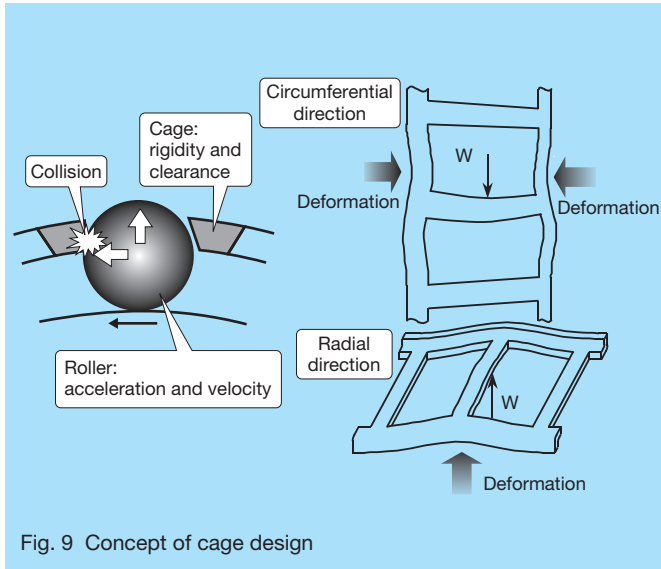

Fig. 9 Concept of cage design

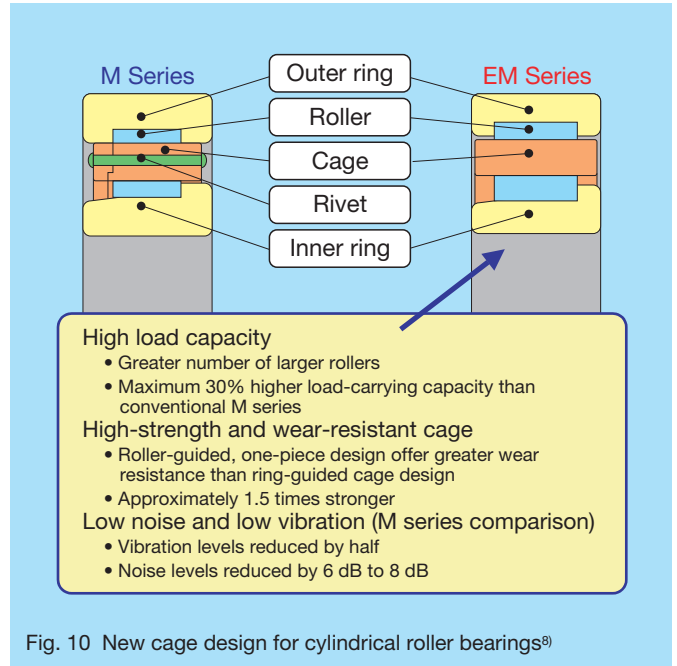

Fig. 10 New cage design for cylindrical roller bearings⁹⁾

4. Engineering Tasks in the Future

As mentioned earlier, larger 5 MW-class wind turbine prototypes in Europe are being put into service. With these larger turbines, greater reductions in component weight have become ever more critical due to the limitations of cranes being used to install the wind turbines. The following examples are changes in newer types of speed-increasing gearboxes that reflect the need to comply with requirements for weight reductions. Details follow each item listed.

- Unification of the main shaft (rotor shaft) bearing and speed-increasing gearbox:** The planetary gear is separated from the speed-increasing gearbox, and integrated to the bore of the main shaft bearing to reduce weight.
- Multi-stage speed-increasing planetary gears:** The conventional planetary gear for a speed-increasing gearbox is converted into a multi-stage planetary gear for a higher speed-increasing ratio, and a more compact and lightweight design.
- Multiple generators:** The use of different sized generators in a single turbine, each with its own different speed of rotation, can greater accommodate varying wind conditions to generate power more efficiently. This design of turbine eliminates the planetary gear carrier, accommodates smaller parts, and helps achieve a lightweight speed-increasing gearbox that is less costly.
- Synchronous generators:** These generators, which are more commonly found in a gearless machine, are capable of generating power under low speed, and are more compact. When combined with a speed-increasing gearbox, synchronous generators allow for a more compact and lightweight nacelle.

We would like to further promote bearing development that contributes to a lightweight speed-increasing gearbox

design while maintaining required performance levels. Fig. 11 shows a comparison of torque fluctuation for the rotor shaft and the high-speed shaft during operations of the speed-increasing gearbox.⁹⁾ As shown in the figure, torque fluctuations occur over a short time, which cause noise in the speed-increasing gearbox. We would like to refine our analytical capability to reflect the influence of vibrating loads from torque fluctuations in the bearing specification. This will enable us to supply bearings with higher reliability under such conditions.

5. Conclusion

NSK's technology for higher reliability in wind turbine bearings was initially focused on speed-increasing gearbox bearings. We will introduce bearings for other applications as opportunities arise. Although the wind turbine industry is relatively new, changes are occurring now at a rapid pace. The current trend is focused on larger unit sizes that incorporate the latest technologies. Standard bearings have sufficed so far in wind turbine applications, but we anticipate growing demand for application-specific bearings in the future.

NSK is confident that we can contribute to the development of the wind turbine industry by supplying highly reliable products that meet or exceed the requirements of new wind turbine bearings using our expertise as a leading bearing maker in addition to taking advantage of our experience in developing bearings for wind turbine applications.

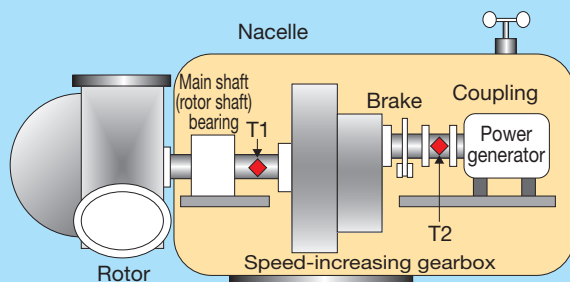

600 kW wind turbine
 Rotating speed: 27 rpm
 Rated input torque: 220 kN·m
 Torque fluctuation for 30 seconds

600 kW-Stall Anlage: Drehmomentschwankung über 30 s

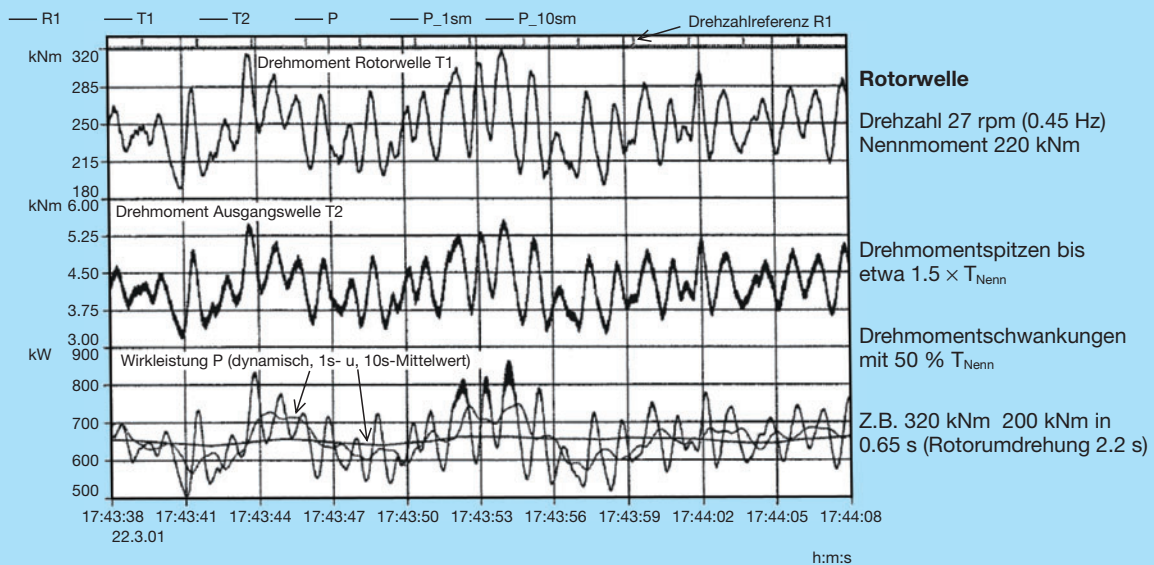

Fig. 11 Torque fluctuation⁹⁾

References:

- 1) BTM Consult ApS "International Wind Turbine Energy Development, World Market Update 2003"
- 2) R. Errichello, J. Muller, "Overview of AGMA/AWEA 6006 Standard for Design and Specification of Gearboxes for Wind Turbine" GEARTECH Report 2070 (2002)
- 3) ANSI/AGMA/AWEA 6006-A03 "Standard for Design and Specification of Gearboxes for Wind Turbines"
- 4) S. Urakami, H. Takemura, "Development of New Life Equation Program, NSK ABLE Forecaster" NSK Technical Journal, 673 (2002) 26-30
- 5) S. Natsumeda, "Computer Simulation Technique for Predicting Performance of Rolling Bearings" NSK Technical Journal, 673 (2002) 31-35
- 6) B. McNiff, W. Musial, "Developing a Wind Turbine Gearbox Load Description" Global WINDPOWER 2004 Conference Proceedings.
- 7) Y. Murakami, N. Mitamura, K. Furumura, "Long Life Super TF & Hi-TF Bearings under Severe Lubrication Conditions" NSK Technical Journal, 652 (1992) 9-16
- 8) T. Murai, S. Tsunashima, O. Fujii "Development of New High Capacity Cylindrical Roller Bearings" NSK Technical Journal, 673 (2002) 40-44
- 9) T. Gellermann, "Reale Belastungen des Antriebsstranges von Windenergieanlagen," 14th International Colloquium Tribology (2004)



Tetsuo Watanabe

Bearing Technologies for Centrifugal Pumps

Hiroshi Ishiguro and Manabu Yamada
Bearing Technology Center

ABSTRACT

There are a large variety of pumps in the world. This article covers the basic structure and operating conditions of centrifugal pumps, which serve a wide range of applications. Additionally, this article will describe the function of bearings and the technologies that have been developed to meet performance requirements of centrifugal pumps.

1. Introduction

Pumps are mechanical devices used in diverse fields to raise, compress, or transfer fluids or gas. Production output is worth 330 billion yen in Japan (2004) with an estimated global output of 3 trillion yen. Pumps can be broadly classified by operating principle: centrifugal pumps (kinetic pumps), positive displacement pumps, and other specialized pumps.

The centrifugal pumps utilize vanes on a rotating impeller to produce high head and high discharge pressure. Positive displacement pumps are generally classified as either rotary pumps or reciprocating pumps, which are used to transfer a set amount of fluids in a forward-only fashion. There are specialized pumps such as jet pumps and pneumatic pumps (Fig. 1). Centrifugal pumps, however, are the most common type of pump, which offer users a wide range of flow, volume capacity, and head. In this paper, we will focus on centrifugal pumps, their required functions, and bearing technology that can meet the needs of these pumps.

2. Basic Structure of Centrifugal Pumps

Centrifugal pumps use vanes on rotating impellers and centrifugal force to add velocity to a fluid as it is flung off

the vanes into the volute casing. The volute configuration transforms the velocity energy into static pressure or pump head as the fluid is discharged. Fig. 2 illustrates the basic structure of a centrifugal pump.

A centrifugal pump consists of a volute casing, and an impeller mounted on a rotating shaft, that is supported by bearings. Any load applied to the shaft will also be applied to the pump-side bearings (front side) and the motor-side bearings (rear side). Mechanical seals are fitted between the pump parts of the drive shaft and front side bearings to prevent leaks.

Principal characteristics of pump bearings:

- Front side bearings are operated under radial load conditions, and the rear side bearings are operated under both radial and axial load conditions.
- Impellers are positioned on the shaft far enough from the front side bearings to allow for mounting of mechanical seals between impellers and front side bearings. This configuration results in the generation of radial loads near the impellers, which results in moment loads being applied to the front side bearings.
- Front side bearings are normally mounted with a clearance fit to protect bearings from excessive internal loads when the shaft expands from heat generated during normal operation. The rear side bearings are normally mounted in the housing with an interference fit to secure the rear side bearings to the shaft.
- Grease is the standard lubricant for these bearings. Under high-temperature operating conditions, an oil-bath lubrication method may be adopted.

Based on these operating characteristics, the front bearings are normally deep groove ball bearings or cylindrical roller bearings that offer high radial load capacity. The rear bearings are typically duplex bearings that offer radial load capacity and high axial load capacity in either direction.

3. Basic Operating Conditions of Centrifugal Pumps

Speed:

Most centrifugal pump shafts are driven by an AC motor via couplings. Shaft speed can be expressed as:

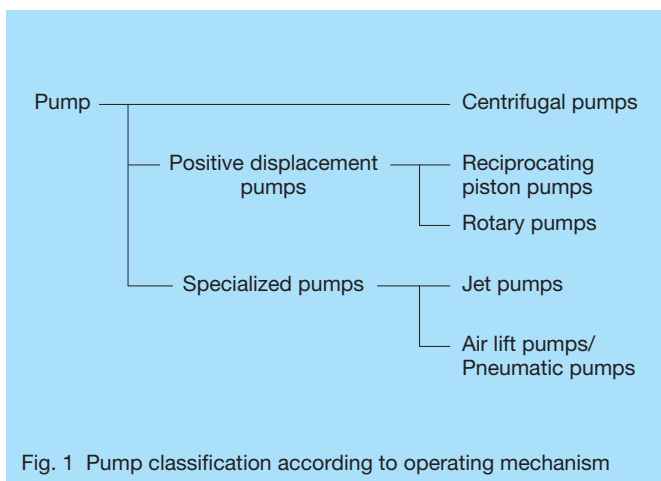

Fig. 1 Pump classification according to operating mechanism

$$N = \frac{f \times 60 \times 2}{p}$$

Where:

p = Pole number

f = Rated frequency

N = Speed (rpm)

The standard value of rated frequency is 50 Hz or 60 Hz. Since the number of poles is either two or four, normal speed averages between 1 500 rpm to 3 600 rpm.

Load:

Centrifugal pump bearings are operated under two basic types of loads. The first type of load is from weight and any imbalance¹ of rotating parts. *Static pressure* or *pump head* that is built up until the pumped fluid leaves the outlet or discharge port² generates another type of load. Impeller design (including single stage or multi-stage) and the volute configuration largely affect pump head/pressure. When difference in static pressure between the front and back of impeller blades (vanes) is great, axial load on the bearings will be high; pumps are designed in various ways to reduce such axial load.

Examples of load are given for heavy-duty petroleum/chemical centrifugal pumps:

Bore diameter 50 mm × 2.5 MPa (inlet pressure)

Front bearing radial load: 550 N

Rear bearing radial load: 350 N

Rear bearing axial load: 4 500 N

4. Bearing Requirements and Related Technologies

4.1 High load capacity

Pump makers are faced with demands to reduce costs and the size of pump systems. While designing more compact pump systems, they must maintain conventional output capacity. Therefore, compact bearings with a high load capacity are also required. NSK's high-load capacity bearing series are one such bearing that meets these requirements. The basic dynamic load rating of these bearings has improved approximately 10%. These bearings also offer a 30% longer service life, which has been achieved by enlarging ball diameters and by optimizing the interior design of cages and more.

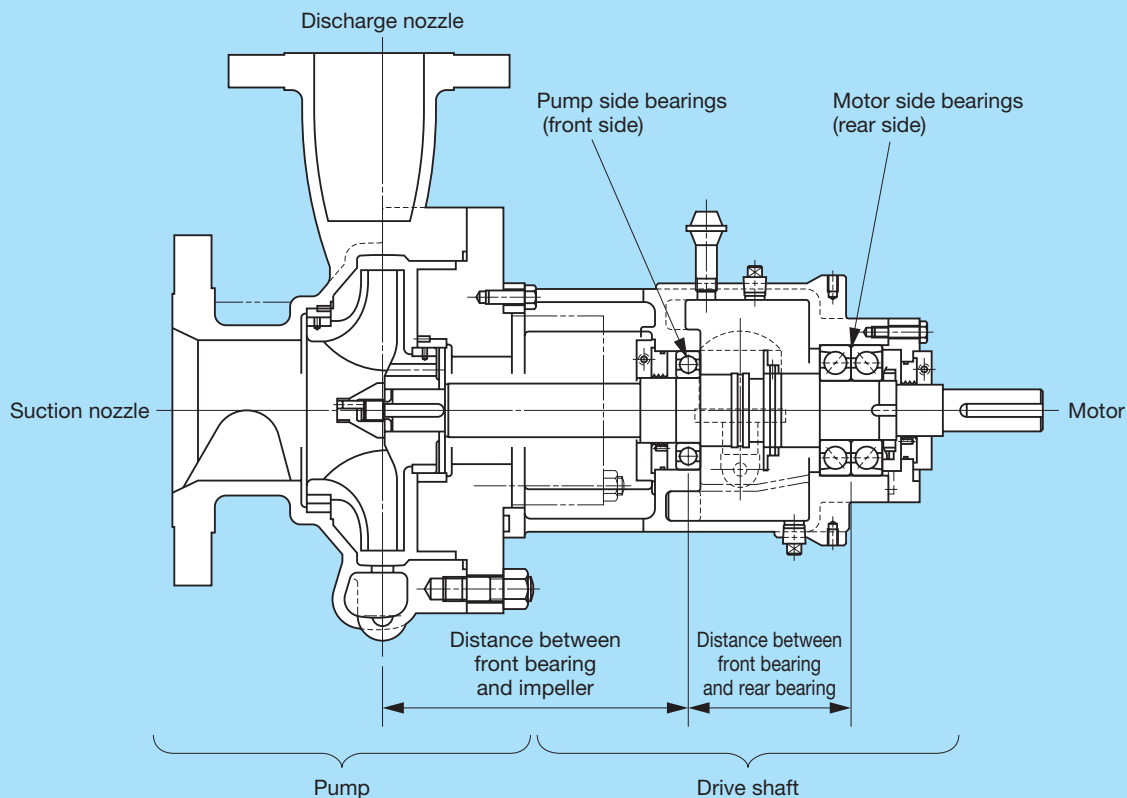

Fig. 2 Basic structure of a centrifugal pump

Table 1 Boundary dimensions and basic dynamic load rating of deep groove ball bearings

Bearing number	Bore diameter (mm)	Outside diameter (mm)	Basic dynamic load rating		
			Standard bearings (N)	High-load capacity bearings (N)	Increase in basic dynamic load rating
6205	25	52	14 000	15 300	9%
6305	25	62	20 600	23 700	15%
6206	30	62	19 500	23 300	19%
6306	30	72	26 700	29 800	12%
6207	35	72	25 700	28 300	10%
6307	35	80	33 500	39 500	18%

Table 2 Boundary dimensions and basic dynamic load rating of angular contact ball bearings

Bearing number	Bore diameter (mm)	Outside diameter (mm)	Basic dynamic load rating		
			Standard bearings (N)	High-load capacity bearings (N)	Increase in basic dynamic load rating
7205	25	52	14 800	16 700	13%
7305	25	62	24 400	25 900	6%
7206	30	62	20 500	22 600	10%
7306	30	72	31 000	34 500	11%
7207	35	72	27 100	31 000	14%
7307	35	80	36 500	38 500	5%

- High-load capacity deep groove ball bearing (Fig. 3)
- High-load capacity angular contact ball bearing (Fig. 4)

Tables 1 and 2 show the boundary dimensions and basic dynamic load ratings of these bearings. For example, compared to a standard bearing, bearing number 6306 ($\phi 30 \text{ mm} \times 72 \text{ mm}$) has the basic dynamic load rating of 26 700 N and a high-load capacity rating of 29 800 N. In other words, the basic dynamic load rating has been elevated by approximately 12%. As a result of this higher load capacity, which has increased by 12% under the same operating time, bearing life has increased by 40% for similar load conditions.

4.2 Long life

Surface originated flaking tends to occur under contaminated lubricating conditions. Surface originated flaking is caused by concentrations of stress that develop

immediately around indentations formed by foreign particles.¹⁾ Fig. 5 illustrates the process of surface originated flaking. UR heat treatment is effective in alleviating the concentrations of stress. This heat treatment process enables the amount of retained austenite to increase in the bearing material and prevents surface originated flaking. Consequently, bearing durability is significantly improved for operations in contaminated environments.

As shown in Fig. 6, the life of UR treated bearings has improved by twice that of standard bearings operating under contaminated lubricating conditions. Additionally, the UR treatment alleviates shearing stress, which is the cause of rolling fatigue. Furthermore, compression stress on the surface works to prohibit the progression of cracks.²⁾ UR treated bearings achieve more than 1.5 times longer life compared with that of standard bearings (Fig. 7).

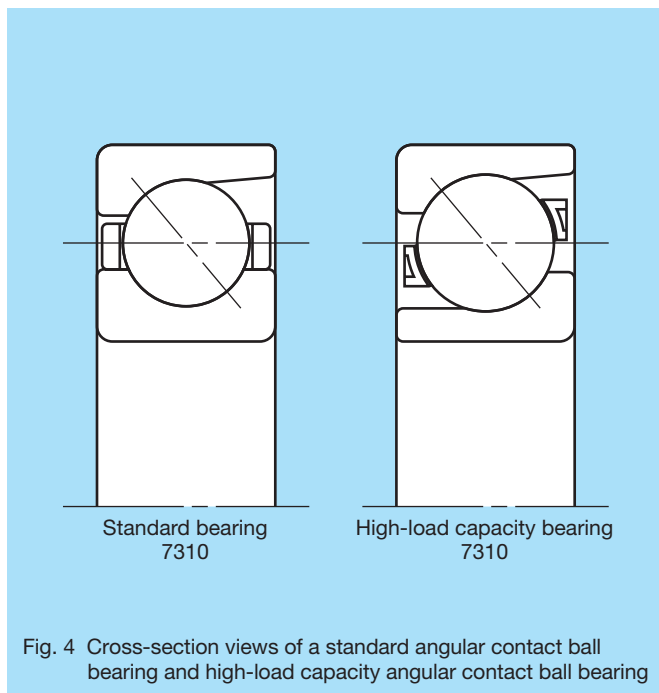
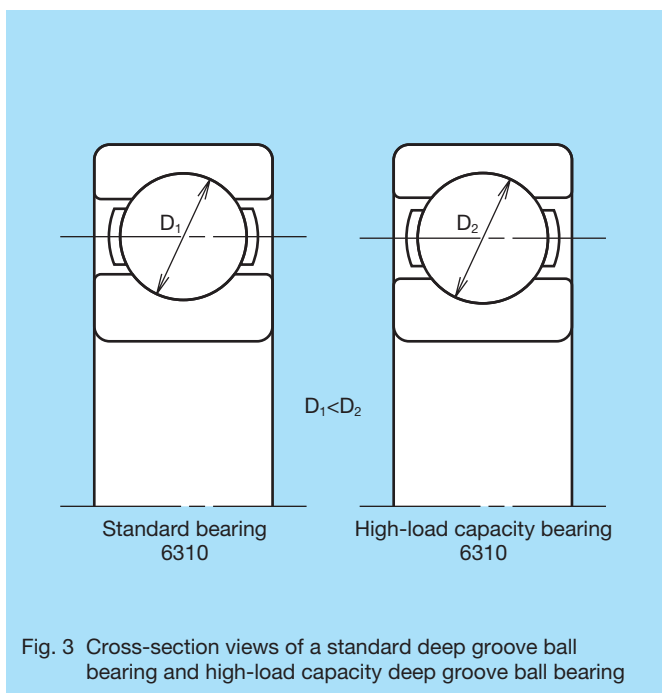

Fig. 3 Cross-section views of a standard deep groove ball bearing and high-load capacity deep groove ball bearing

Fig. 4 Cross-section views of a standard angular contact ball bearing and high-load capacity angular contact ball bearing

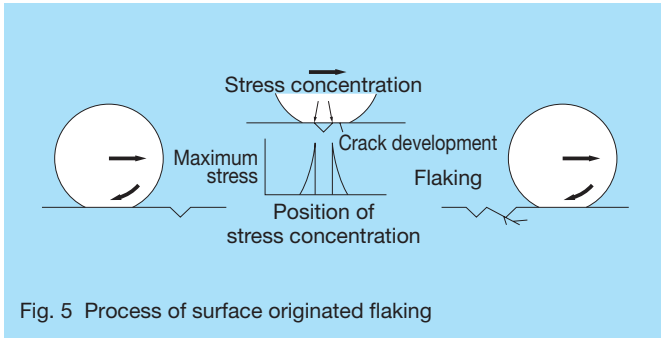

Fig. 5 Process of surface originated flaking

4.3 Creep resistance

The uneven flow of fluid, and the whirling motion and imbalance of the impeller generate load on the driving shaft of the pump. In both cases, it is very difficult to eliminate the loads thoroughly. If loads become excessively high, wear may occur between the bearing outside surface and housing bore due to low-speed sliding (creep). Progress of creep causes excessive shaft vibration, which can trigger abnormal oscillation and lead to impeller damage.

Common measures against creep include a tight fit with sufficient interference. For pumps, however, a tight fit can be hardly adopted because it makes pump assembly more difficult, and does not allow for additional loading caused by swelling of the shaft due to heat generation. NSK provides anti-creep bearings as a solution to this problem. Anti-creep bearings come with O-rings installed into two grooves on the outer ring. Frictional force of the O-rings helps to prevent occurrence of creep (Fig. 8).

4.4 Low heat generation

The American Petroleum Institute Standard 610³⁾ (API Std 610 - Centrifugal Pumps for Petroleum, Petrochemical and Natural Gas Industries), which is equivalent to ISO 13709, specifies requirements for centrifugal pumps. Among the requirements for centrifugal pumps and other types of pumps that this standard applies too, limitation of lubricant temperatures is among one of the more important factors that greatly affects temperature rise of bearings. The following list highlights major factors affecting temperature rise:

- Select grease that is appropriate for the operating conditions. Pack the correct amount of grease; too much grease or too little grease greatly affects temperature rise.
- A negative clearance can result in excessively high temperature rise. Proper shaft and bearing fitting are needed to ensure sufficient internal clearance of bearings (normal clearance is generally adopted).
- Improper mounting causes the bearing temperature to rise greatly. Particular attention should be paid to inclination of inner and outer rings.

4.5 Bearing specifications

Bearing sizes and types are determined according to load conditions, as shown in Table 3.

5. Conclusion

In this article, we have discussed the design and operating conditions of centrifugal pumps, and the required functions and technologies of rolling bearings

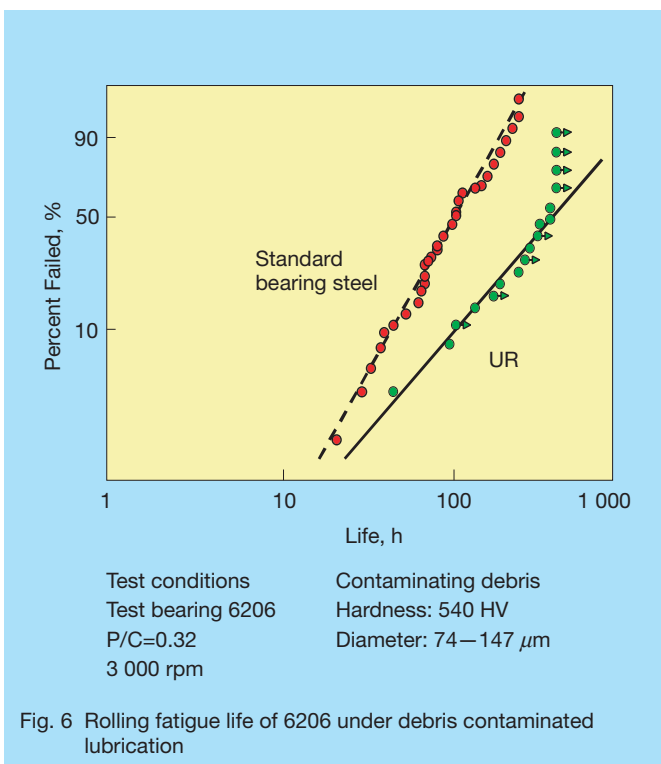

Fig. 6 Rolling fatigue life of 6206 under debris contaminated lubrication

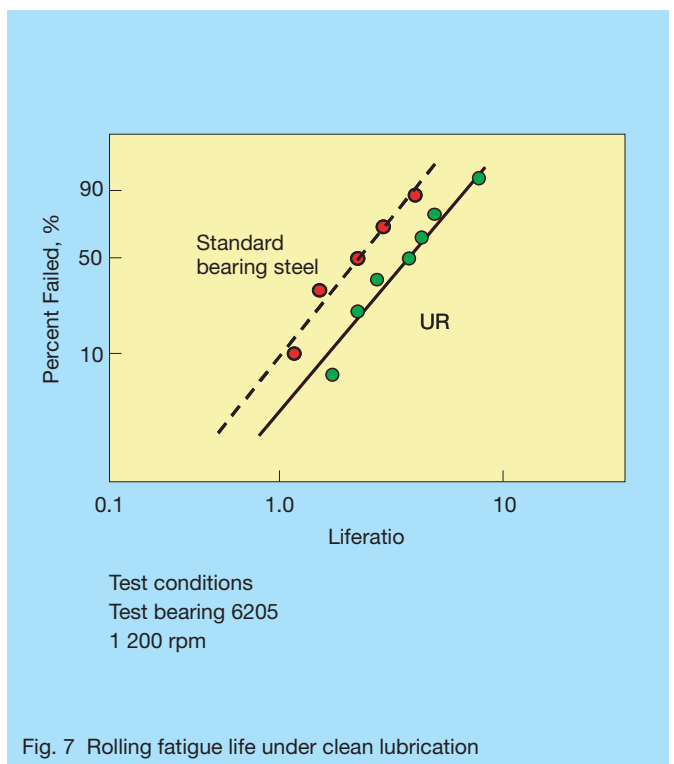

Fig. 7 Rolling fatigue life under clean lubrication

Table 3 Bearing types and specifications of pumps

Part	Bearing type	Bearing number (bore diameter)	Cage material	Internal clearance	Fit (JIS B8313)	
					Shaft	Housing
Front side bearing (free end)	Deep groove ball bearing	6205 to 6320	Steel or synthetic resin	Normal clearance	js6/k6	H7
	Cylindrical roller bearing	NU205 to NU320				
Rear side bearing (fixed side)	Duplex angular contact ball bearing	7205 to 7320				
	Double-row angular contact ball bearing	5205 to 5314				

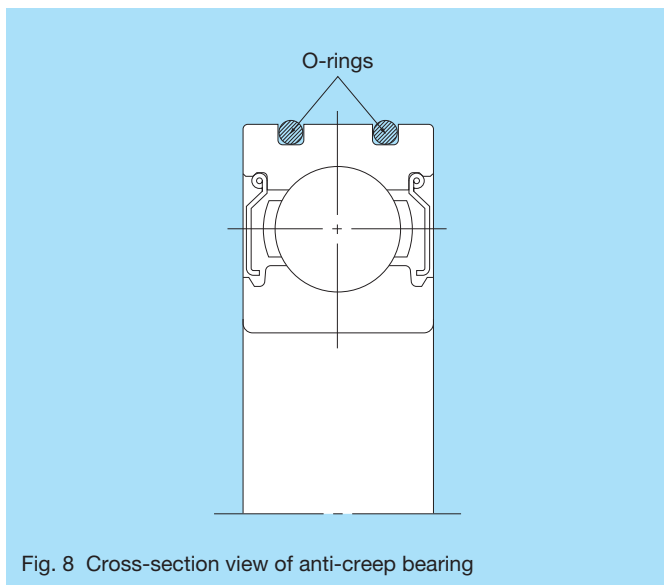

Fig. 8 Cross-section view of anti-creep bearing



Hiroshi Ishiguro



Manabu Yamada

used in these pumps. Centrifugal pumps can be found in the petroleum, chemical, electric power, construction, and water supply industries to name a few. In the future, pumps will be developed using integrated analysis and design capabilities to become unitized systems instead of stand-alone pumps, and will offer greater compactness, higher performance, and enhanced reliability. At NSK, we will work to further improve our proprietary technologies and provide pump makers with bearings commensurate with their latest developments and advancements.

References:

- 1) Y. Murakami, Y. Matsumoto and K. Furumura “Long Life TF Bearing under Contaminated Lubrication” NSK Technical Journal 650 (1989). 1-11
- 2) K. Furumura “Influence on Fatigue Life by Residual Stress” NSK Technical Journal 627 (1971). 1-8
- 3) American Petroleum Institute Standard 610 – “Std 610 - Centrifugal Pumps for Petroleum, Petrochemical and Natural Gas Industries”

Trends of Bearing Technology in Iron and Steel Industries

Takamasa Ohira
Bearing Technology Center

ABSTRACT

Ensuring stable operations and highly efficient production have been important issues faced by the steel mill industry over the years given that it is an equipment-intensive and core industry. Universal demands of long life and high reliability are required of bearings used in iron and steel works. The severe operating conditions of bearings in these industries include exposure to fine iron powder (iron oxide), water, and high temperatures. The operating environment also includes heavy loads, shock loads, high vibration levels, and rapid acceleration and deceleration cycles. Such operating conditions are rarely found in other industries. NSK has been developing bearing materials and bearing designs aiming to extend operating life and further improve reliability of bearings in order to respond to customer needs. The focus of this article is on bearings for continuous casting mills and rolling mills, and the severe operating conditions in which they must operate.

1. Introduction

The iron and steel industry is a core industry in that its products are used in a majority of industries such as the automotive, construction, electrical appliance, and shipbuilding industries. The iron and steel industry is also a process industry that requires vast amounts of initial investment. After World War II, Japan, Europe, and the USA were the dominant steel producers of the world. From the 1970s, however, Korea and China started to assume greater prominence (Fig. 1).

Amidst ongoing globalization, industry reorganization is underway in Japan, Europe, and the USA. Bearings for iron and steel works have been developed in response to the drastically changing business environment of iron and steel companies throughout the world. Although the needs of the industry continue to change, the fundamental requirements of bearings remain the same: long life and high reliability under harsh operating conditions in order to ensure stable production performance of iron and steel works.

2. Trends of Bearings at Iron and Steel Works

Bearings for iron and steel works are used throughout the entire steel making process, starting with bearings used in raw material yard (or scrap yard) equipment, and equipment for the melting, refining, and rolling processes.

All types of bearings, from normal bearings standardized by ISO to exclusive bearings developed by NSK, are used in each steel making process.

The harsh operating environment of bearings includes not only exposure to fine iron powder (iron oxide), scale, water, dust, and heat, but also exposure to heavy loads, shock loads, high vibration levels, and rapid acceleration and deceleration cycles.

As shown in Table 1, NSK has implemented measures to enhance the service life and reliability of bearings

continuously and has developed new exclusive bearings for various iron and steel works applications. In this article, some primary examples will be introduced.

2.1 Continuous casting mill bearings

As described earlier, most equipment used at iron and steel works operate under severe conditions, but with conditions for continuous casting mills (CCM) being the most severe. As shown in Fig. 2, molten iron is poured into a mold where the liquid steel gradually solidifies. The material is then passed through rollers and pressed under a heavy load to form semi-finished shapes. Solidification is achieved by spraying the molten steel with large quantities of water, which creates an environment of high temperatures and high humidity.

Bearings supporting the rolls are rotated at extremely low speed of only several rotations per minute and are operated under heavy load conditions, which equate to

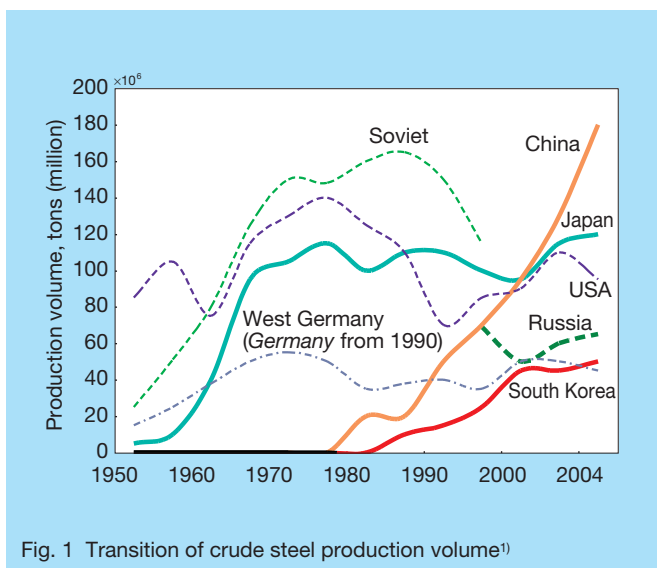

Fig. 1 Transition of crude steel production volume¹⁾

Table 1 Chronological development of NSK bearings for iron and steel works

Bearings for continuous casting mills		Sealed-Clean spherical roller bearing							SWR™ bearing
			Cylindrical roller bearing with aligning ring		Oil-air lubrication equipment with abnormality detection system			Tapered roller bearing with aligning ring	
		Split bearing unit							
Bearings for rolling equipment		Sealed-Clean roll neck bearing			High-capacity Sealed-Clean roll neck bearing			Extra-capacity™ Sealed-Clean roll neck bearing	
		Special grease for Sealed-Clean bearing			Super-tough roll neck bearing			WTF™ roll neck bearing	
		Specified bearings for new types of rolling mills			Stud-type four-row cylindrical roller bearing				
Other bearings for iron and steel works		Sealed-Clean bearing for wheel of sintering line						Molded-Oil™ bearings for iron and steel works	
		Sealed-Clean bearing for chain conveyer							
		Leveler unit			Sealed-Clean cylindrical roller bearing for medium roll of sintering line				
			Split bearing for trunnion of converter					SNN plumber block	
				Sizing press bearing					
	1980	1985	1990	1995	2000	2005			

more than 30% of the bearings' basic dynamic load rating. Therefore, it is difficult to draw lubricant into the contact surface of the inner and outer ring raceways and the rolling surface of the rollers; the lubricating oil film, which is fundamentally necessary, is hardly formed.

Furthermore, when contamination from water spray, water vapor, and scale (from the metal surface) infiltrates the bearings, marginal lubrication conditions develop, and metal contact is generated at the roller-to-race interface.

Bearings with aligning capability are used in a continuous casting guide roll (Fig. 3) due to problems of mounting method and roll rigidity under heavy-load rolling. Spherical roller bearings are used in the locating position of the guide rolls, which can endure both radial and thrust loads. Or tapered roller bearings with an aligning ring, which were recently developed by NSK, are also used. Cylindrical roller bearings with an aligning ring and split full-complement cylindrical roller bearing units are mainly used for the free-end of the guide rolls.

2.1.1 Spherical roller bearings

Whereas spherical roller bearings rotate with differential slip at the surface of inner and outer ring raceways and the rolling surface of rollers, premature failure will occur by following typical failure modes if they are used under harsh conditions, like those of a continuous casting mill.

In addition to extremely low rotating speed, heavy load,

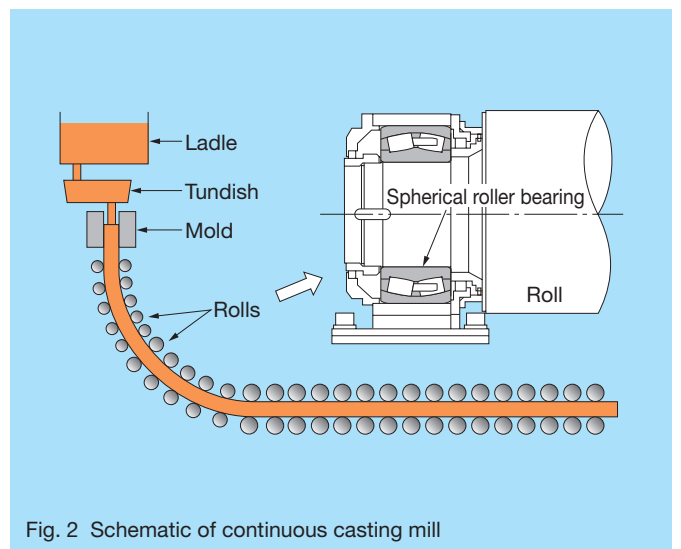

Fig. 2 Schematic of continuous casting mill

and improper lubrication due to contamination (water spray, water vapor, scale), differential slip, which is peculiar to spherical roller bearings (Fig. 4), results in direct metal-to-metal contact between the roller and raceway, which further increases wear (Fig. 5), and ultimately leads to flaking, cracking, and then fracturing (Photo 1 & Fig. 6).

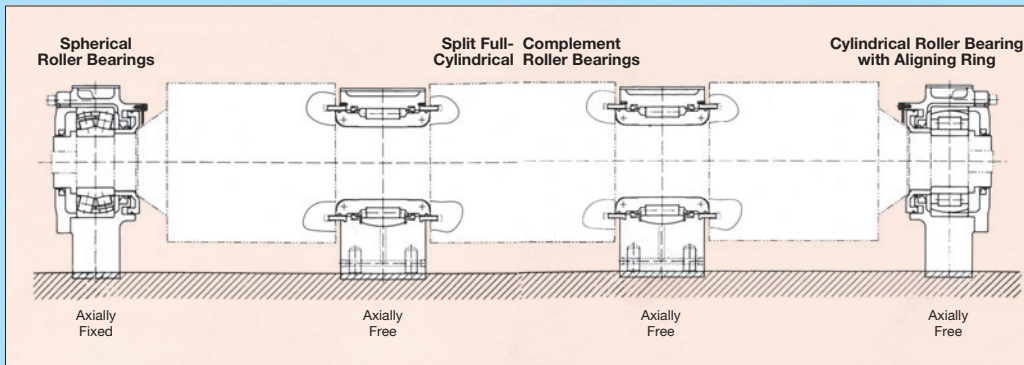
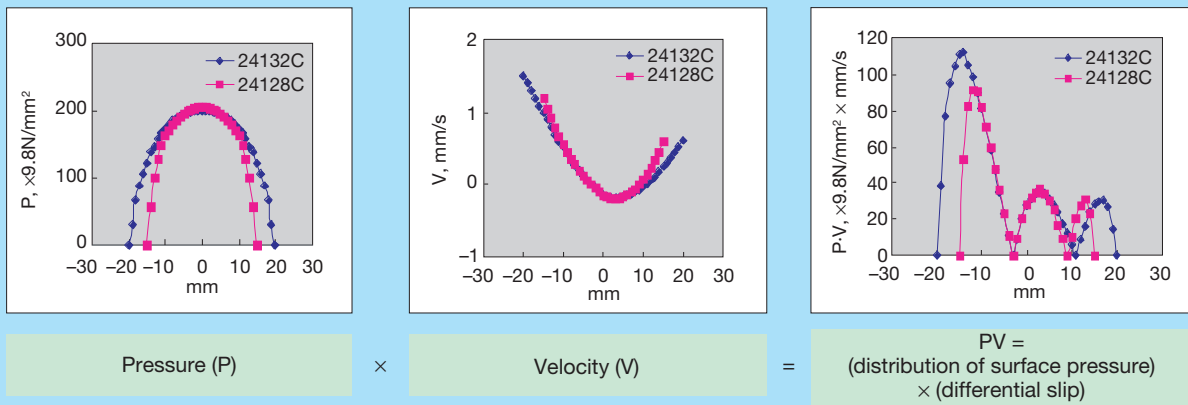

Fig. 3 Segmented drive rolls for continuous casting mill



Bearing No. 24128C
Radial load $F_r = 200$ kN
Bearing No. 24132C
Radial load $F_r = 280$ kN

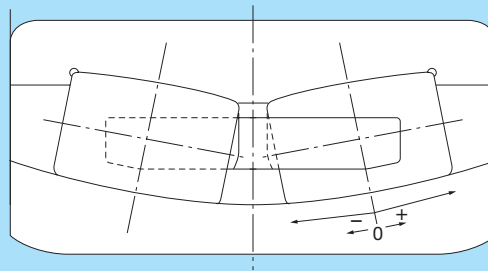

Fig. 4 Relationship among surface pressure distribution between the outer ring raceway and rolling contact surface, and differential slip under the highest load acting on a rolling element

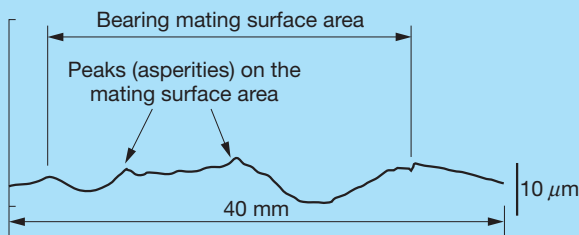

Fig. 5 Cross-section profile of outer ring raceway (after six months running operation)

In the end, problems with the bearing can cause any of the numerous rolls of the caster to jar or misalign, leading to a sticker breakout in the slab and in the worst case, cause the entire mill to shut down.

Therefore, NSK developed and commercialized a new material to ensure stable bearing operation under such severe conditions: SWR (super wear-resistant) bearing steel. Spherical roller bearings made from this material (SWR bearings),²⁾ offer dramatically improved reliability in continuous casting applications.

Significantly improved wear resistance and superior flaking life have been achieved in the SWR bearings by

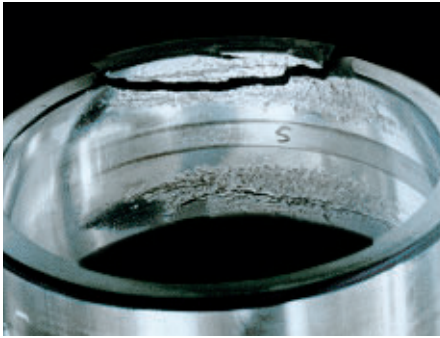

Photo 1 Damaged outer ring raceway

precipitating hard and fine-grained carbonitrides of several nanometers by applying the latest carbonitriding technology to NSK's original developed steel, which includes vanadium. Surface hardening of SWR bearing steel offers increased core toughness, and is highly resistant to cracking compared with through-hardened AISI 52100 steel. Based on field results in the marketplace, SWR bearings achieve a service life that is more than two times longer than that of spherical roller bearings made of conventional steel for actual CCMs.

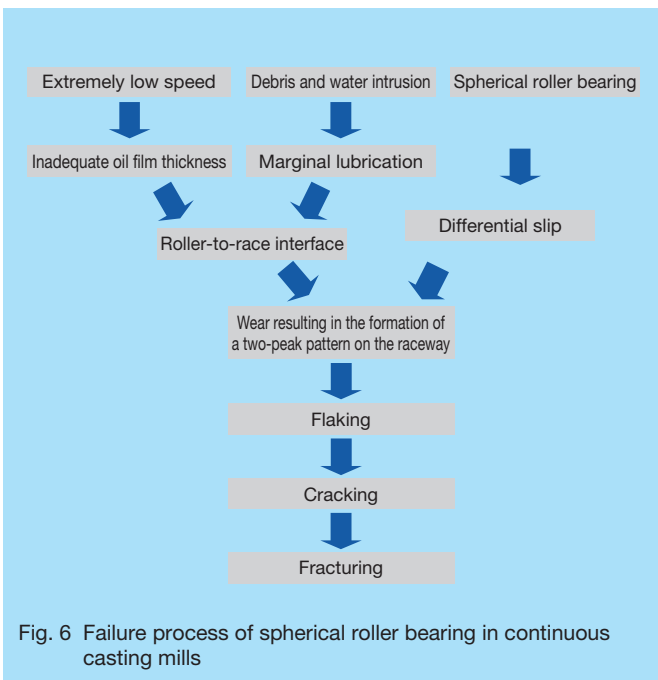

Fig. 6 Failure process of spherical roller bearing in continuous casting mills

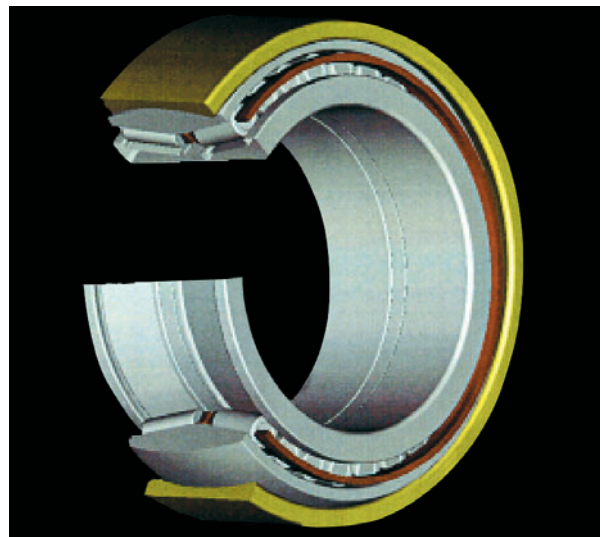

Photo 2 Tapered roller bearing with aligning ring



Photo 3 Cylindrical roller bearing with aligning ring

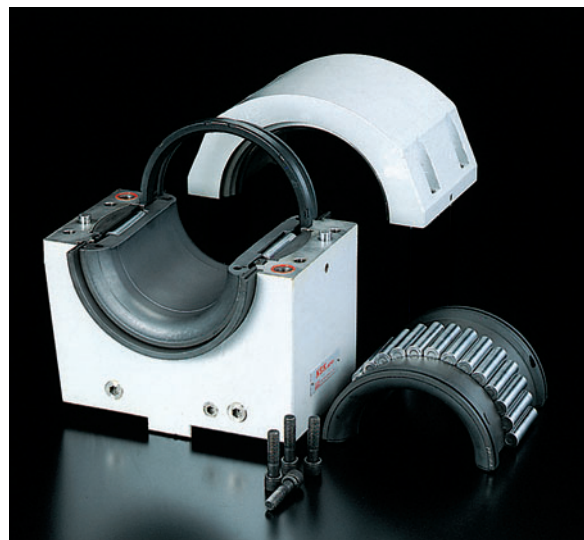

Photo 4 Split roller bearing units for segmented drive rolls

2.1.2 Tapered roller bearing with aligning ring, full complement cylindrical roller bearing with aligning ring, and split full complement cylindrical roller bearing unit

NSK has developed tapered roller bearings with an aligning ring (Photo 2). This aligning mechanism was developed for tapered roller bearings, which have a high axial-load carrying capacity and are free of differential slip on raceways. NSK has begun commercialization of this bearing for the locating (fixed) position of CCM guide rollers.

For the non-locating (float) position, full complement cylindrical roller bearings with an aligning ring (Photo 3) are already commercialized as our conventional type. These bearings can compensate smoothly for the thermal length variations of the shaft caused by the high temperatures of molten steel slabs because smooth movement in the thrust direction can be performed between rolling elements and the inner ring during rotation with a full complement design that enables high-load carrying capacity. Split roller bearing units (Photo 4) that use cylindrical rollers have been commercialized. These bearings continue to be rated highly by customers because of their high reliability.

2.2 Roll neck bearings for rolling mills

The process of rolling mills heavily influences the quality of the final product, which consists of a harsh environment and severe operating conditions as are also found in the operating environment of continuous casters. There are many rolling processes depending on the final product, such as strips and plates, hot-rolled sheet, cold-rolled sheet, bars, structural shapes, wire, and rods. Furthermore, the type of mill used varies according to the final product, such as two-high, four-high or six-high mills.

The four-high rolling mill, which is representative of mills used in the rolling process (Photo 5 and Fig. 7), consists of work rolls, which make direct contact with steel sheet, and backup rolls, which support the work rolls. In a six-high rolling mill, there are intermediate rolls between the work rolls and backup rolls.

Four-row tapered roller bearings with grease lubrication

are used mainly for the roll neck bearings of work rolls and intermediate rolls. Backup rolls use four-row cylindrical roller bearings for radial loads, and double-row tapered roller bearings for axial load. These bearings use grease, forced-circulation oil lubrication, oil mist lubrication, or oil-air lubrication.

Operating conditions of roll neck bearings in rolling mills are primarily heavy loads, vibrations, impact loads, and contamination (water spray, water vapor, and scale). Conventionally, large amounts of replenished grease lubricant have been required to prevent an accident caused by improper lubrication. However, growing concern over the environmental impact of such lubricating systems has increased demand by steel mills for greater reductions in the amount of required lubricant used in rolling mills.

NSK has made great strides in developing roll neck bearings for rolling mills in both aspects of material and design for the purpose of providing users with bearings that meet the universal needs of higher reliability and longer life.

2.2.1 Four-row tapered roller bearings for roll necks of work rolls and intermediate rolls

In the 1970s, NSK developed the world's first sealed four-row tapered roller bearing for roll necks. This bearing achieved extended maintenance-free performance by inserting oil seals to the roll neck bearings to prevent sudden emergencies due to improper lubrication, and drastically reduced grease consumption.

However, since seals were used in the bearing, bearing load capacity was reduced when compared to conventional bearings of the same boundary dimensions (bore diameter \times outside diameter \times width) with no seal. Although seal performance was remarkably improved in comparison to conventional open-type bearings, users tended to use them for extended periods of time due to their maintenance-free performance. Eventually, however, contamination from water and scale found its way into the bearing. Significant reductions in maintenance costs were achieved, but overall service life in real-world applications was extended only slightly longer than that of conventional bearings.



Photo 5 Four-high rolling mills

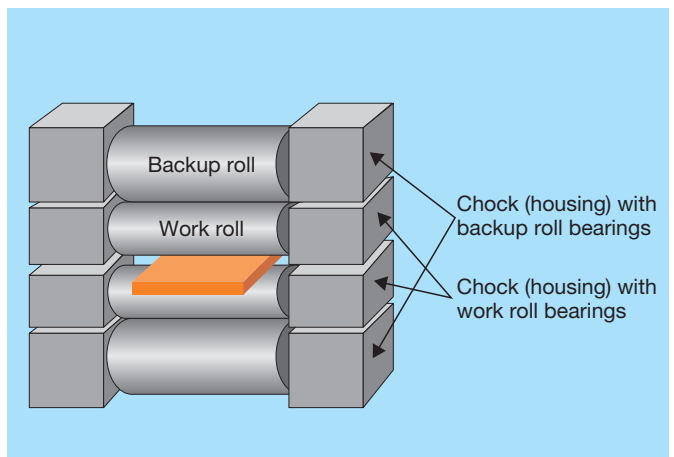

Fig. 7 Basic construction of a four-high rolling mill

In order to accomplish higher reliability and longer life of bearings, NSK implemented research and development focusing on bearing material and bearing design, and succeeded in the development of new products in the 1990s as follows.

(1) Super-TF™ bearing (Super tough bearing)³⁾

We clarified that when foreign matter, such as steel particles, intrudes into the bearing, surface areas of the inner and outer ring raceways and rolling surface of the rollers suffer from flaking. The flaking process consists of foreign matter being crushed on surface areas between the raceway and roller. Indentations are formed where stress concentrations are initiated at a debris dent on a bearing surface with each passing of a

roller. Stress concentrations at the edges of the indentations lead to the generation of cracking, which propagate into flaking (Fig. 8). As a measure against flaking, NSK developed the Super-TF bearing. This development was achieved by a carbonitriding heat treatment of new SAC steel. Specifications of this steel include adequate amounts of chromium and molybdenum, and the surface retained austenite content is controlled to an optimum level. As a result, NSK succeeded in mitigating stress concentrations at the indentation edges under contaminated environment conditions, and accomplished enhanced bearing life.

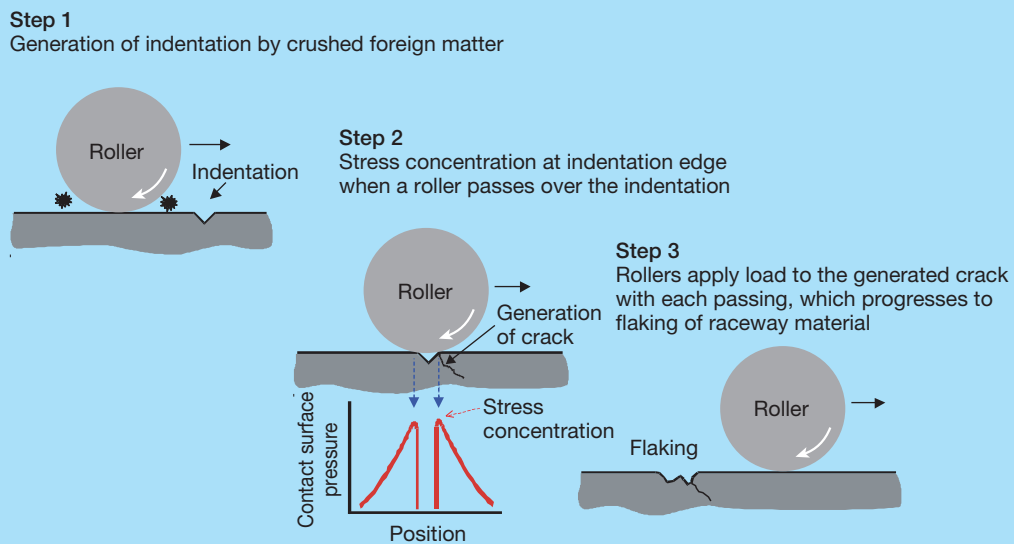

Fig. 8 Process of surface originated flaking

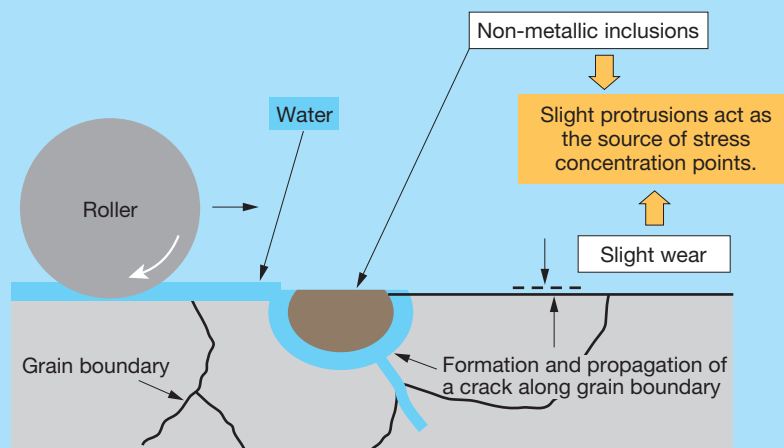

Fig. 9 Mechanism of water infiltrated flaking

(2) WTF™ bearing (Water-tough bearing)^{4), 5)}

NSK clarified the mechanism where flaking occurs in a bearing used in a water-infiltrated environment. As wear on the raceway surface develops, nonmetallic oxide inclusions become protrusive and act as the source of stress concentration points. The high stresses cause cracking to initiate at the matrix in contact with nonmetallic oxide inclusions. Cracks propagate along grain boundaries where material strength has been weakened, ultimately resulting in water-induced flaking and bearing failure (Fig. 9).

Several measures have been taken for each aspect of the flaking process discussed earlier. The generation of cracks is controlled first by using super-clean steel. An optimum alloy balance inhibits the propagation of cracks along the grain boundaries, which promotes enhanced service life under water-infiltrated conditions. As a measure against debris contaminated lubrication, the surface retained austenite content is controlled to an optimum level by a special heat treatment process, which enhances service life by mitigating the stress concentration points that form at the indentation edges. These measures have been combined to create NSK's recently developed WTF bearing.

(3) Extra-capacity™ Sealed-Clean roll neck four-row tapered roller bearings⁶⁾

Extra-capacity Sealed-Clean roll neck four-row tapered roller bearings (Fig. 10) adopt a specially designed oil seal configuration and a uniquely

fabricated cage that increase the dynamic load rating of the bearings by about 30% compared to conventional sealed-clean roll neck four-row tapered roller bearings. Furthermore, a new bore seal prevents negative pressure that causes water entry.

The new bore seal improves water entry resistance by more than 75% than that of a conventional bearing, which achieves longer lubricant service life.

As a result, extra-capacity Sealed-Clean roll neck four-row tapered roller bearings achieve enhanced service life and extended maintenance-free performance. In fact, this bearing has been recognized for its longer life, which is more than twice as long as that of conventional sealed-clean roll neck four-row tapered roller bearings in the marketplace.

2.2.2 Roll neck four-row cylindrical roller bearings for backup rolls

Cold rolling is the most important rolling process for ensuring final product quality of steel plate. Four-row cylindrical roller bearings offer higher robust performance than conventional oil film bearings to ensure bearing rigidity for change of rolling speed, rolling load, and bearing temperature. Since the 1960s, four-row cylindrical roller bearings have been used for the backup roll of cold rolling equipment to ensure critical control of plate thickness.

At present, most newly installed cold rolling mills and refurbished rolling mills adopt four-row cylindrical roller bearings. To improve roll runout accuracy, which directly affects plate thickness accuracy, the outside surface of the roll and inner ring raceway are ground simultaneously after shrink-fitting the inner ring of the four-row cylindrical roller bearing onto the roll neck.

To increase basic dynamic load rating, a pin-type cage had been adopted, which required a hollow roller. Under extreme heavy rolling load, however, the inner surface of the hollow roller suffered under repeated stress, which occasionally generated cracks that led to fractures. In the 1990s, NSK developed a four-row cylindrical roller bearing with a stud-type cage using solid rollers (Photo 6) as a

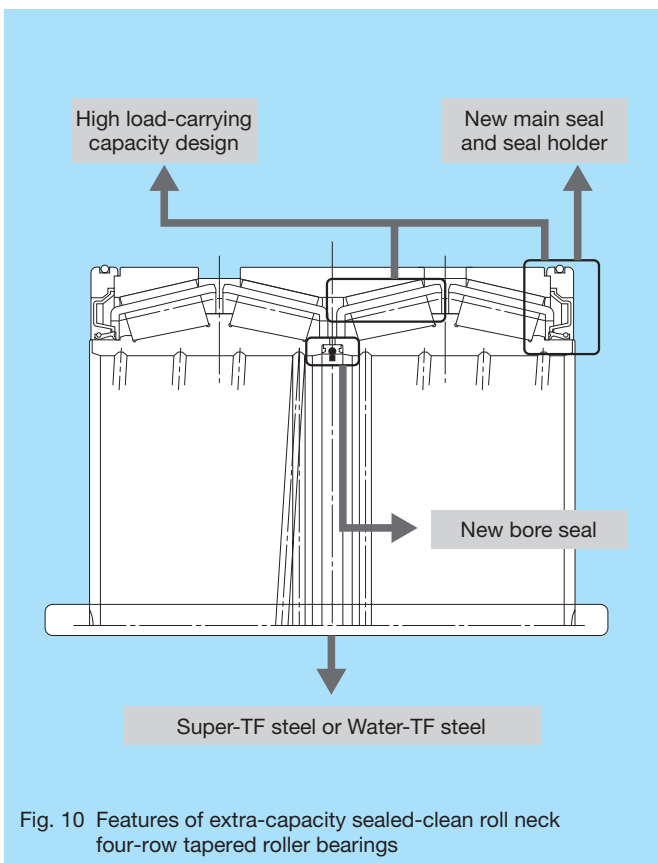

Fig. 10 Features of extra-capacity sealed-clean roll neck four-row tapered roller bearings



Photo 6 Four-row cylindrical roller bearings with stud-type cage

Table 2 Technical requirements for each steel production process and solutions

Application	Conditions	Typical problems	Measures
Sintering line	High temperature, low speed, and dust	Wear, flaking, and seizure	Prelubricated bearing with heat resistance grease, and heat resistance treatment for material
Converter	Bearing replacement is difficult because of large structure.	Replacement of failed bearing is time consuming	Ultra-large split-type bearing for trunnion
Continuous casting mills	Extremely low speed, heavy load, high temperature, high humidity, contamination, and axial load due to thermal expansion	Wear and flaking and potential fracture of outer ring	SWR spherical roller bearing, cylindrical roller bearing with aligning ring, and tapered roller bearing with aligning ring
Rolling mills (roll neck)	High speed, heavy load, water and scale contamination	Flaking	Extra-capacity Sealed-Clean roll neck bearing, Super-TF bearing, and Water-TF bearing
Refining line	Prevent adhesion of lubricant to finished product	Leaked lubricant adheres to product	Sealed-clean bearing and Molded-Oil bearing

solution to this problem. Due to the increasingly severe operating conditions of backup rolls, NSK uses super-tough bearing specifications for all four-row cylindrical roller bearings in cold rolling mills.

3. Conclusion

In this article, we have reported on bearings for continuous casting mills and bearings for rolling mills. The technical requirement for each steel production process is shown in Table 2. NSK will continue research and development for bearing design, bearing type, bearing material, lubricants, lubrication methods and develop measures against the severe operating conditions of bearings used in the iron and steel industry.

NSK has extended bearing life and enhanced bearing reliability to meet the need for improved productivity in the iron and steel industry. NSK will continue to focus future efforts in response to demand from the iron and steel industry for value-added products that lessen environmental impact and extend maintenance-free performance.



Takamasa Ohira

References:

- 1) "Iron and Steel Statistic Directory" by The Japan Iron and Steel Federation.
- 2) K. Yamaura, and M. Oohori "Development of SWR Bearing" NSK Technical Journal No. 673 (2002)
- 3) Y. Murakami, N. Mitamura, K. Furumura "Long Life Super TF & Hi-TF Bearings under Severe Lubrication Conditions" NSK Technical Journal No. 652 (1992)
- 4) Y. Matsumoto "Development of Water Tough Bearing for Steel Mills" NSK Technical Journal No. 672 (2001),
- 5) Y. Matsumoto, Y. Murakami, and M. Oohori "Rolling Contact Fatigue Under Water-Infiltrated Lubrication" NSK Technical Journal No. 675 (2003)
- 6) T. Aizawa, K. Akagami, and S. Tanaka, "Development of NSK Extra-Capacity Sealed-Clean Roll Neck Bearings for Rolling Mills" NSK Technical Journal No. 669 (2002)

Automatic Grease Replenishing System for Machine Tool Main Spindles —Fine Lub II

Saburo Azumi
Bearing Technology Center

ABSTRACT

In recent years, environmental issues have exerted stricter anti-pollution pressures on industry across the globe. This has drawn attention to technologies that conserve natural resources, prevent environmental contamination, reduce noise pollution, achieve maintenance-free performance, and improve overall working conditions.

NSK's grease replenishment system for machine tool main spindles uses an external pump that intermittently delivers exact amounts of grease to the bearing interior. This grease replenishment system extends bearing life for use in high-speed applications. Furthermore, high-speed applications running in the range of $d_m n$ value 1.8×10^6 can take advantage of this system, which has been the mainstream realm of oil-air and oil-mist lubricating systems. This grease replenishment system protects the working environment by eliminating stray oil mist or leakage, and saves energy by reducing the large demand for continuously compressed air of oil-air and oil-mist lubricating systems.

1. Introduction

Machine tool makers in Japan and Europe are continually working to further improve the productivity of their products. Flagship products of machine tool makers exhibited at recent expos and trade shows include highly functional multi-task machine tools that incorporate information technology with ultra-high speed and high-precision capabilities.

Many environmentally friendly products exhibited at recent machine tool trade shows reflect the demand among various industries for environmentally sound products. Machine tool makers have focused on technologies that improve the working environment and extend maintenance-free performance including enhancing energy conservation, and reducing environmental pollution and noise.

NSK has developed and commercialized a new automatic grease replenishing system for machine tools that is compatible with the newer generations of machine tools.

2. Development Background

2.1 Current status and challenges of high-speed spindle lubrication

Machine tool spindle bearings typically require a minimum life of 10 000 to 20 000 hours under continuous high-speed operations. Conventionally, grease-lubricated bearings have been used in limited applications due to the limits of grease life in the range of $d_m n$ value 1.3×10^6 (dm: pitch circle diameter; n: running speed), which is shorter than rolling fatigue life. Applications operating at higher speeds have thus adopted oil-air or oil-mist lubricating systems that consistently provide fresh oil lubricant.

However, environmental problems related to oil lubrication continue to persist. Examples include stray oil mist, oil leakage, excessive energy consumption required

for ensuring sufficient quantities of compressed air, and excessive generated when compressed air hits against rolling elements. These are the reasons why high-speed operation with grease lubrication has been desired.

2.2 Development concept

In order to meet the need of grease lubrication under high-speed operating conditions, we developed an automatic grease replenishing system that focused on meeting the following objectives:

- Operating capability in a range of $d_m n$ value 1.8×10^6 for a machine tool spindle equipped with the automatic grease replenishing system
- Bearing structure that can accommodate grease replenishment under high-speed operations
- Maintenance-free performance during 10 000 to 20 000 hours of continuous high-speed operations

3. Features of the Automatic Grease Replenishing System

3.1 Outline

The Fine Lub II automatic grease replenishing system consists of an externally positioned piston pump that supplies small shots of grease to the interior of spindle bearings at regular intervals. This replenishment system enables machine tool users to take advantage of the superior seizure resistance properties of grease in a non-traditional application for increased speed and assured lubrication.

3.2 Methods of grease replenishment.

Fig. 1 illustrates the three methods that were approached for replenishing grease in machine tool spindle bearings; replenishment from the inner ring, from the lateral side, and from the outer ring. We conducted tests

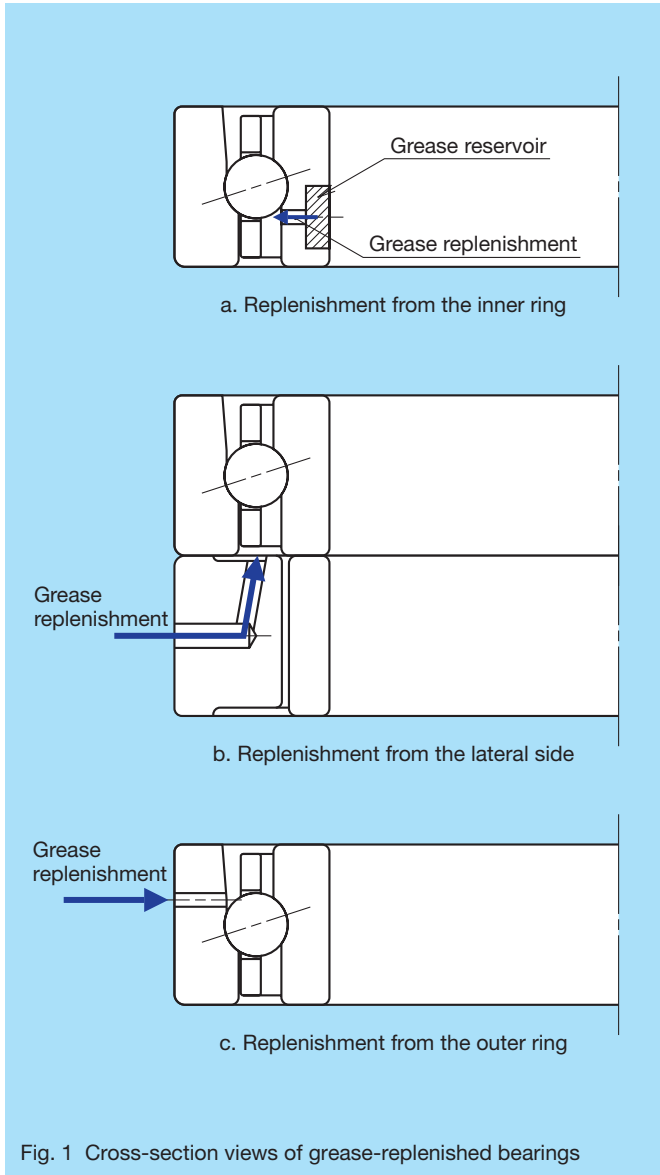

Fig. 1 Cross-section views of grease-replenished bearings

and determined that it was difficult to supply shots of grease via the inner ring (Fig. 1, a) due to the influence of centrifugal force. Supplying grease from the lateral side (Fig. 1, b) is the same method used in oil-air and oil-mist lubrication systems where a nozzle and spacer are used to supply oil. Therefore, supplanting grease lubrication from the lateral side is a simplified process for spindles that have adopted oil-air or oil-mist lubrication. Yet, tests of replenishing grease from the lateral side resulted in grease being discharged due to weight of the grease itself before reaching the raceway surface of the inner and outer rings. We learned that grease replenishment with this method was difficult.

Replenishment from the outer ring (Fig. 1, c) proved to be most advantageous for supplying grease directly to the bearing interior in comparison to the other methods. Various tests were performed to confirm our findings, which resulted in adopting the replenishing method from the outer ring.

Table 1 Test results showing temperature variations of grease-replenished bearings

Grease quantity (cm ³)	Bearing temperature variations	
	Grease replenishment under spindle rotation	Grease replenishment after stopping spindle rotation
0.07	No temperature rise	No temperature rise
0.10	No temperature rise	No temperature rise
0.15	1 °C temperature rise	No temperature rise
0.30	2 °C temperature rise	No temperature rise

3.3 Quantity of grease and replenishing cycle

Quantity of grease

Care should be used when supplying grease to the bearing interior because the rolling friction of the bearing itself and churning of the lubricant can cause heat generation, resulting in substantial temperature rise. We measured the temperature of an outer ring during grease replenishment under spindle rotation and measured again after spindle rotation was stopped.

Table 1 lists the measurements that were taken. Grease in the amount of 0.07 cm³ to 0.3 cm³ (0.5% to 2% of free internal bearing space) was fed to the interior of a bearing with a bore diameter of 65 mm during non-rotation and during a rotating speed of 20 000 rpm. This measurement was taken after spindle rotation reached 20 000 rpm.

We can see that temperatures varied if the amount of replenished grease exceeded 0.15 cm³ during bearing rotation. However, there were no temperature variations if the amount of replenished grease was less than 0.30 cm³ (2% of free internal bearing space). Based on these results, we determined that the amount of a single shot of grease should be less than or equal to 1% of free internal bearing space.

Replenishing cycle

We know that a position-preloaded bearing running continuously in the range of $d_m n$ value 1.8×10^6 will suffer from overheating and possible bearing seizure due to the relatively short life of grease, which is on average several

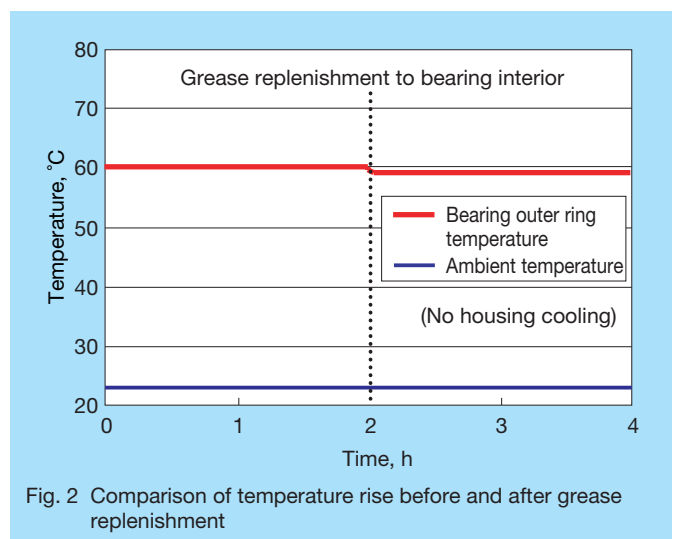

Fig. 2 Comparison of temperature rise before and after grease replenishment

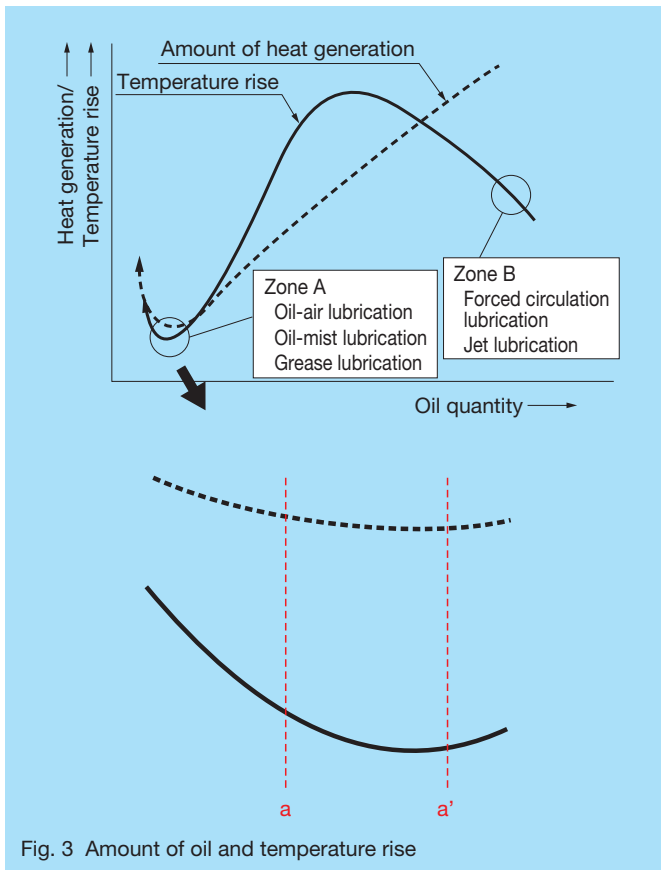

Fig. 3 Amount of oil and temperature rise

hundred hours. Therefore, it is imperative that grease be replenished before the end of grease life.

A 3 000-hour durability test was conducted under the following conditions to learn if it was possible to prevent bearing seizure (premature failure) by extending grease life. The bore diameter of the bearing was $\phi 65$, the quantity of each shot of grease was 0.075 cm^3 (0.5% of free internal space of the bearing), replenishing cycle was 24 hours, and

the running speed was 22 000rpm (rotational speed was $d_m n$ value 1.8×10^6). In order to confirm temperature variations of the bearing outer ring, the housing was left void of any cooling.

Fig. 2 illustrates the bearing temperature when grease was fed into the bearing interior during the durability test. After grease replenishment, bearing temperature fell by about 1°C to 1.5°C . In Fig. 3, [a] represents temperature rise of the bearing at a running speed of 22 000 rpm ($d_m n$ value 1.8×10^6) before grease replenishment. Condition [a] becomes [a'] because heat generation was restrained by grease replenishment and bearing temperature decreased.

After 3 000 hours of durability testing, there was no damage to the bearing, which confirmed that grease replenishment is an effective means of ensuring bearing service life under grease relubricating conditions. With this newly developed automatic grease replenishing system, temperature variations can be controlled by shortening replenishing cycles and setting the grease shot quantity from 0.01 cm^3 to 0.02 cm^3 .

3.4 Automatic grease replenishing system

3.4.1 Design of replenishment system

The basic design of the automatic grease replenishing system (Fig. 4) includes one piston pump connected to independent grease supply lines for each bearing, which is the fundamental design used in oil-air lubrication systems. Grease discharged from the piston pump can be fed to the bearing interior without compressed air, which would be normally required in an oil lubrication system.

We adopted an air-driven piston pump for this replenishment system since the necessary grease supply line is easy to install. Switching the solenoid valves off and on controls the piston pumps. Solenoid valve 1 in Fig. 4 drives the pistons, while solenoid valve 2 supplies grease from the tank to the pistons. Compressed air is scarcely consumed since it is only used for activating the pistons.

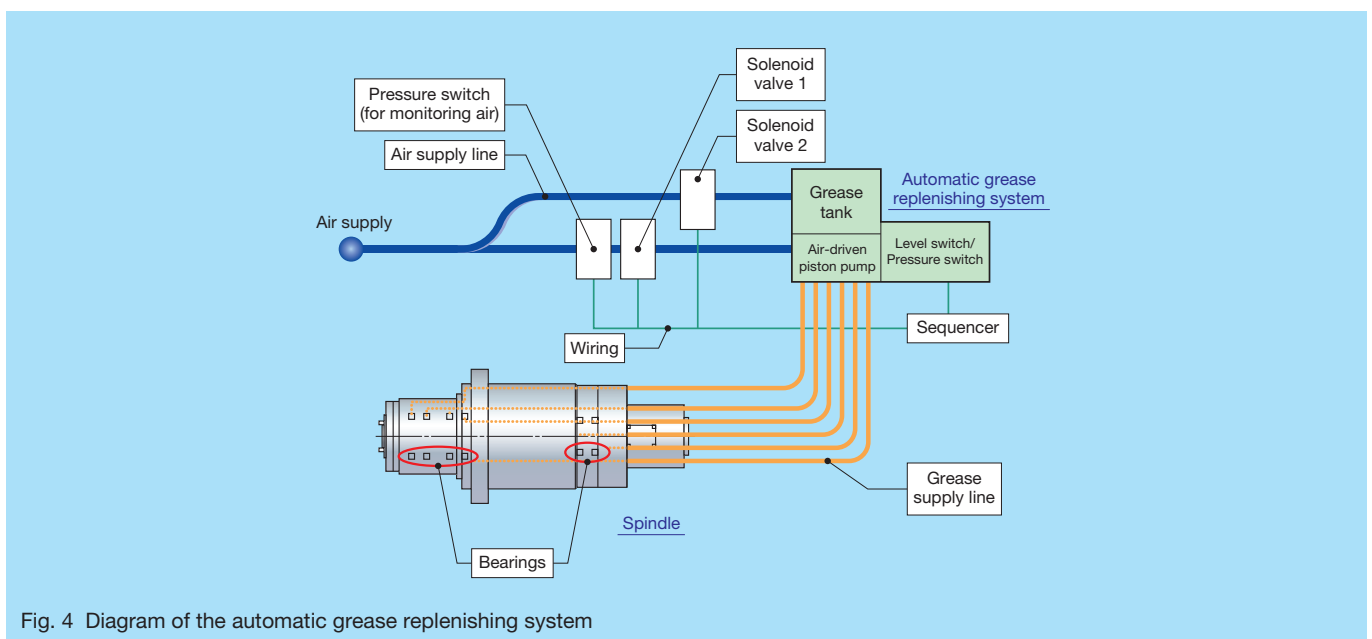

Fig. 4 Diagram of the automatic grease replenishing system

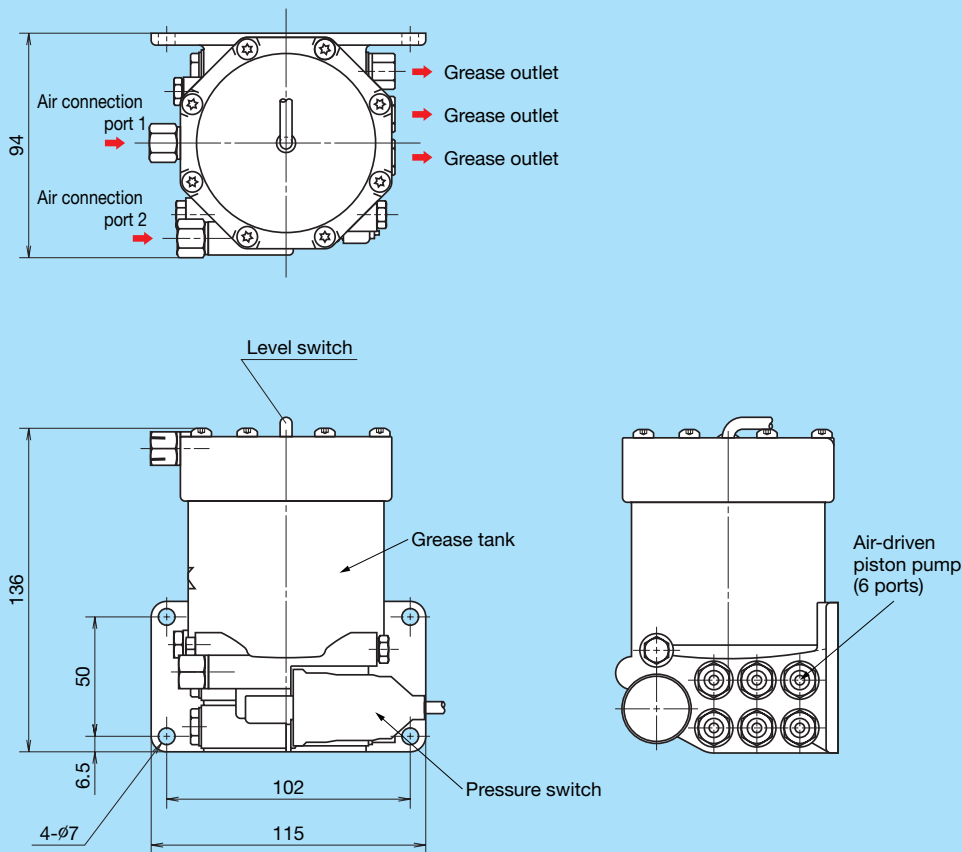

Fig. 5 Schematic views of automatic grease replenishing system

3.4.2 Automatic grease replenishing system

Photo 1 and Fig. 5 show the Fine Lub II automatic grease replenishing system that we have commercialized.

Table 2 lists the four primary components of this system and describes their functions.

For low speed operation, it is possible to minimize the consumption of grease stored in the grease tank by extending the replenishing interval. Under this condition,



Photo 1 Fine Lub II automatic grease replenishing system

an NC controller ladder program determines when to supply grease according to spindle running speed. The running speed is checked at regular cycles and prescribes specific factors for four ranges of speed: low, medium, high, and extra high. The factors are added to a sequence counter and when the integrated value reaches a specified value, grease is replenished.

A machine tool spindle can operate continuously at a rotational speed of $d_m n$ value 1.8×10^6 with a bearing of a bore diameter of 65 mm rotating at a speed of 20 000 rpm for 10 000 hours and grease output per six-hour cycle to six bearings from a 200 cm³ grease tank. Continuous operation of the spindle of more than 100 000 hours is possible under conditions $d_m n$ value 1.4×10^6 with a bearing diameter of 65 mm rotating at a speed of 17 000 rpm for more than 100 000 hours.

3.4.3 Grease supply line

The grease supply lines between the grease replenishing system and the machine tool spindle bearings are made from fluoropolymer and designed with a simple configuration (Fig. 4). The grease supply lines are particularly effective in resisting water, ensuring smooth flow of grease output, and are easier to handle than steel tubes. Maximum line length is 2.5 meters.

Table 2 Automatic grease replenishing system parts

Item name	Function
Air-driven piston pump	Fixed quantities of grease (0.01 cm ³ to 0.02 cm ³ per cycle) are fed from six ports.
Grease tank	Maximum grease storage capacity is 200 cm ³ . Stored grease is fed to the piston pump. The storage capacity assures 10 000 hours of continuous service (in a six-row bearing configuration, with fixed quantities of grease 0.02 cm ³ fed at a 6-hour cycle).
Pressure switch	Grease tank pressure monitor. (ON switch indicates pressured grease.)
Level switch	Low grease level alarm (Alarm is activated when grease level becomes 5% or less.)

3.4.4 Grease selection

In order to provide the bearing interior with the right amount of grease, it is necessary to ensure that the base oil and thickener do not separate between cycles while in the grease supply line. We conducted tests to determine

the effect of different grease products that sit idle in the grease supply line over an extended period of time. In this test, two types of grease were fed into separate grease supply lines. The first test sample used NSK's MTE grease (Ba complex thickener) and the other sample used



Photo 2 Comparison of grease under high-pressure testing

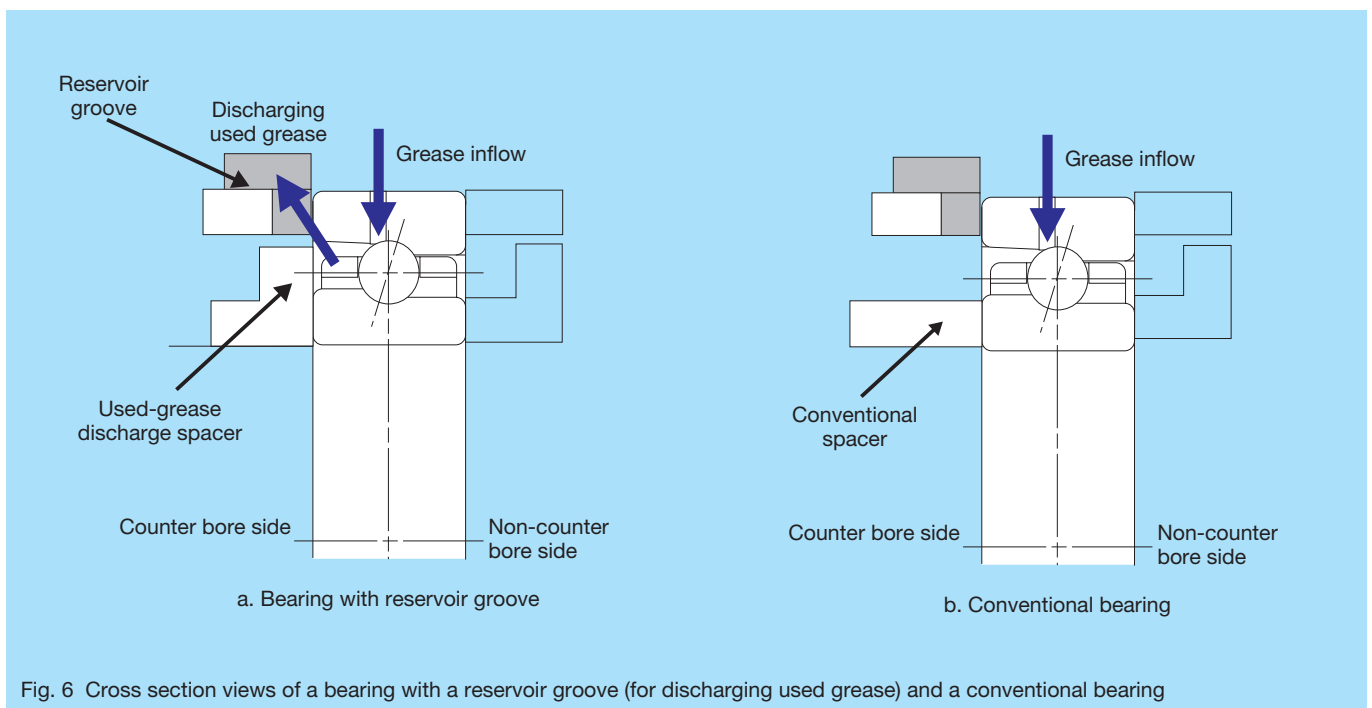

Fig. 6 Cross section views of a bearing with a reservoir groove (for discharging used grease) and a conventional bearing

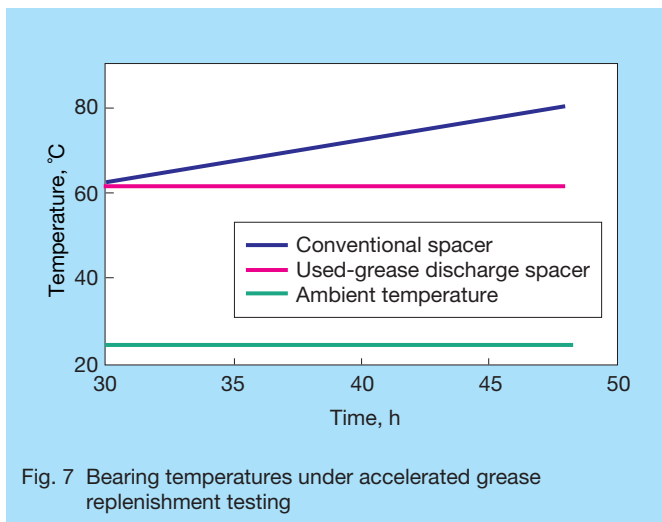

Fig. 7 Bearing temperatures under accelerated grease replenishment testing

conventional grease. Both grease products were fed into the grease supply lines under 0.4 MPa of pressure for a duration of one week. Photo 2 illustrates the results of testing. MTE grease (left photo) remained intact while the other grease (right photo) showed significant separation of base oil and thickener. Based on these results, NSK's Fine Lub II automatic grease replenishing system uses NSK MTE grease.

3.5 Grease discharge structure

Excessive grease can cause overheating due to churning. Proper discharge of used grease is necessary to prevent heat buildup. Fine Lub II uses used-grease discharge spacers on the counter bore side of angular ball bearings, which enable the smooth discharge of used grease. Used-grease reservoir grooves are also designed into the bearing housing (Fig. 6, a).

The bore diameter of the test bearing is $\phi 65$ and running speed is 20 000 rpm. We performed comparative tests of a bearing with used-grease discharge spacers (Fig. 6, a) to a bearing with normal spacers (Fig. 6, b) to determine effectiveness of grease flow. The grease replenishment cycle was shortened to 7.5 minutes, since this was an *accelerated* test, which was followed up with outer ring temperature measurements.

Fig. 7 shows temperature rise under *accelerated* grease replenishing conditions. The bearing with normal spacers showed elevated temperatures after about 30 hours as the quantity of grease accumulated in the bearing. The bearing with used-grease discharge spacers showed no change in temperature. Even after 100 hours of *accelerated* testing, bearing temperature remained stable. These results confirm that used grease was being properly by this spacer design.

4. Conclusion

The NSK Fine Lub II automatic grease replenishing system has been developed to be a more environmentally friendly product than conventional oil-air lubrication and oil-mist lubrication systems. With this development, the limiting speed of a bearing with grease lubrication has been extended by 30% of $d_m n$ value. We achieved maintenance-free performance in excess of 10 000 hours in a machining center with a #40 tool shank operating at 20 000 rpm. The Fine Lub II automatic grease replenishing system provides users with the latest in technological developments that have been adapted to meet the needs of the marketplace and support the needs of our customers in the machine tool industry.



Saburo Azumi

S3 Ball Screws: Super Low-Noise Ball Screws for Automation Equipment

Toshiharu Kajita and Eiji Hayashi
Corporate Research and Development Center

ABSTRACT

NSK has combined proprietary ball screw technologies to develop an extremely quiet, high-end BSS series ball screw. The name S3 (pronounced S-cube) comes from the three S's in "BSS-Super Type." This ball screw is approximately 10 dB quieter than conventional ball screws with a shaft diameter ranging from 15 mm to 32 mm, and a lead ranging from 10 mm to 25 mm. The S3 ball screw has been developed for automation equipment operating at high speeds under light load.

1. Introduction

The BSS series of high-speed, low-noise ball screws (Photo 1) has been highly evaluated by the market for delivering quiet, high-speed performance in a compact size. This positive evaluation reflects the growing importance of controlling noise associated with high-speed devices as well as an increased interest in reducing noise from an environmental perspective.

NSK has now developed a definitive, low-noise ball screw as a high-end version of its BSS series, which combines proprietary ball screw technologies. The new series is named S3 after the three S's in BSS-Super Type and is pronounced "S-cube." The S3 ball screws are designed for automation equipment operating under high-speed, light-load operating conditions, with shaft diameters ranging from 15 mm to 32 mm and leads ranging from 10 mm to 25 mm. This report provides details of this new product.

2. Noise Classification Associated with Ball Screws and Evaluation Method

Fig. 1 shows the classification of noise associated with ball screws. Noise generation falls under two major categories: 1) noise generated by vibrations of the ball screws themselves, and 2) noise generated by vibrations of the base structure where the ball screws are mounted.

For the latter category, it is difficult to make generalizations about noise resulting from various properties since noise generation depends on properties of individual platforms. Because some correlation may exist between noise and vibration of ball screws, which are the source of vibration, it is subsequently important to evaluate vibration as well as noise. The use of a cover for noise abatement cannot prevent this second category of noise because although the cover dampens the noise, it cannot decrease vibration in the base structure. Therefore, this study targeted measures for addressing the source of noise instead of simply treating the noise itself, and evaluated both vibration and noise.

Our evaluation of noise focused only on ball screw noise. We measured and evaluated noise using the noise and

vibration measuring equipment shown in Fig. 2 by the method given in reference 1 with a microphone positioned 400 mm from the shaft center.

Ball screw noise is divided into pulsating noise, generated by repeated collision of moving balls with various parts, and rolling noise, generated by balls rolling against inaccuracies of the raceway surface.

Pulsating noise is further divided into three subcategories: 1) noise at the entry point of the unloaded zone, generated by the collision of balls with other components when they are scooped up from screw grooves into the recirculation component; 2) noise in the unloaded zone, generated by the collision of balls with various parts as they pass through the recirculation circuit; and 3) noise at the exit point of the unloaded zone, which is considered to be generated when balls exit from the unloaded recirculation circuit and enter the loaded zone of the screw grooves, showing correlation with the level of load.

Because ball noises originating at the entry point of the unloaded zone and in the unloaded zone are generated by the collision of the balls, noise levels depend to a large degree on the mass of the balls. Conversely, rolling noise is divided into waviness noise, which is attributed to periodic inaccuracies of the raceway surface, and waviness noise



Photo 1 High-speed and low-noise ball screws, BSS series

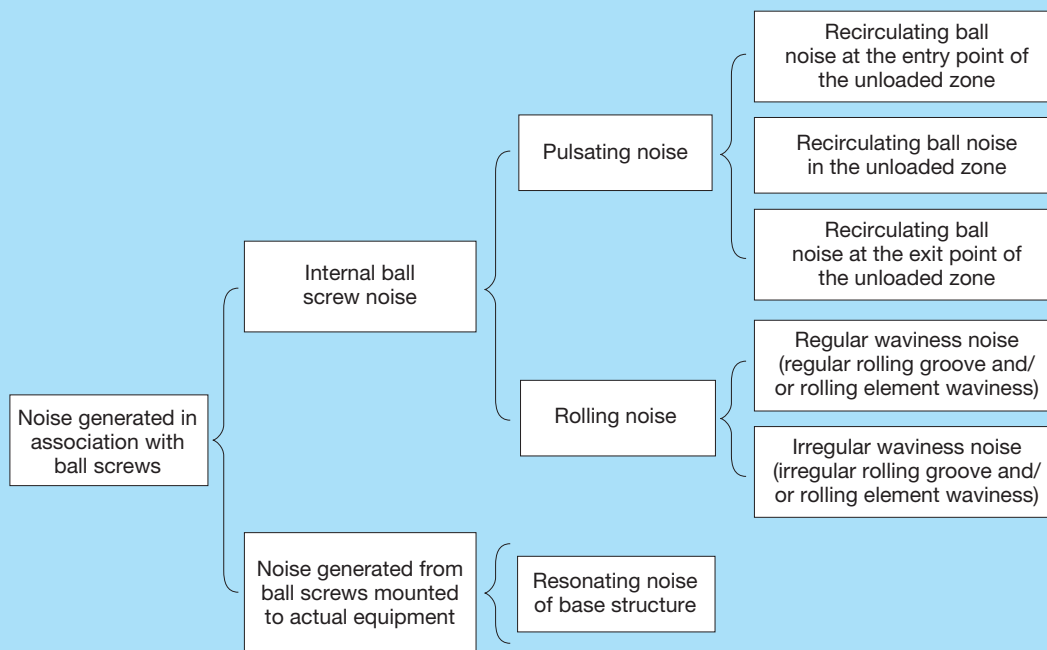

Fig. 1 Classification of ball screw noise

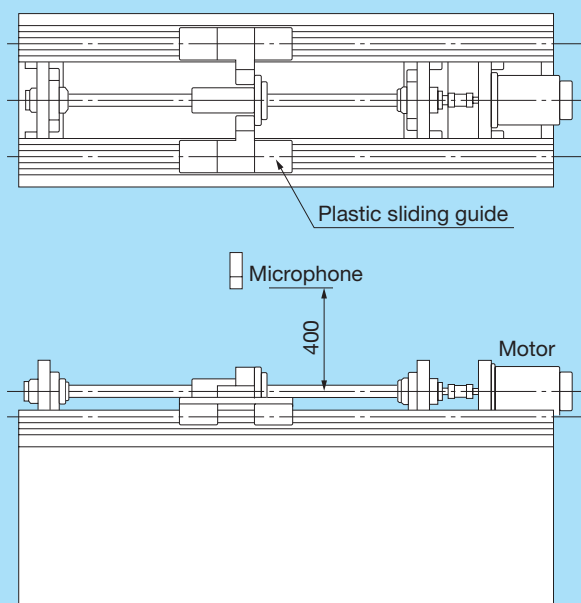

Fig. 2 Noise and vibration measuring equipment

from random waviness, attributed to irregular inaccuracies of the raceway surface. Since the inaccuracy level on the raceway surface has actually little to do with the dimension of ball screws, the ratio of inaccuracy relative to the basic dimension works against smaller sized ball screws.

Because the generation mechanisms for each noise classification vary according to a specific noise, effective measures will differ accordingly. In order to ensure effective noise reduction, it is necessary first of all to grasp the dominant type of noise within the overall generated noise. This requires expertise in identifying the dominant noise by grasping the characteristics and nature of the individual noise classifications. It should be noted that the dominant noise will subtly vary according to such factors as ball screw specifications and operating conditions.

3. Noise Reduction in the BSS Series

The ball noise at the entry point of the unloaded zone, expressed as a periodic pulse-shape noise in reference 2, is dominant within the overall noise generated in association with conventional ball screws. The BSS series effectively reduces noise by reducing ball noise while providing for higher speed by controlling the collision force of balls at

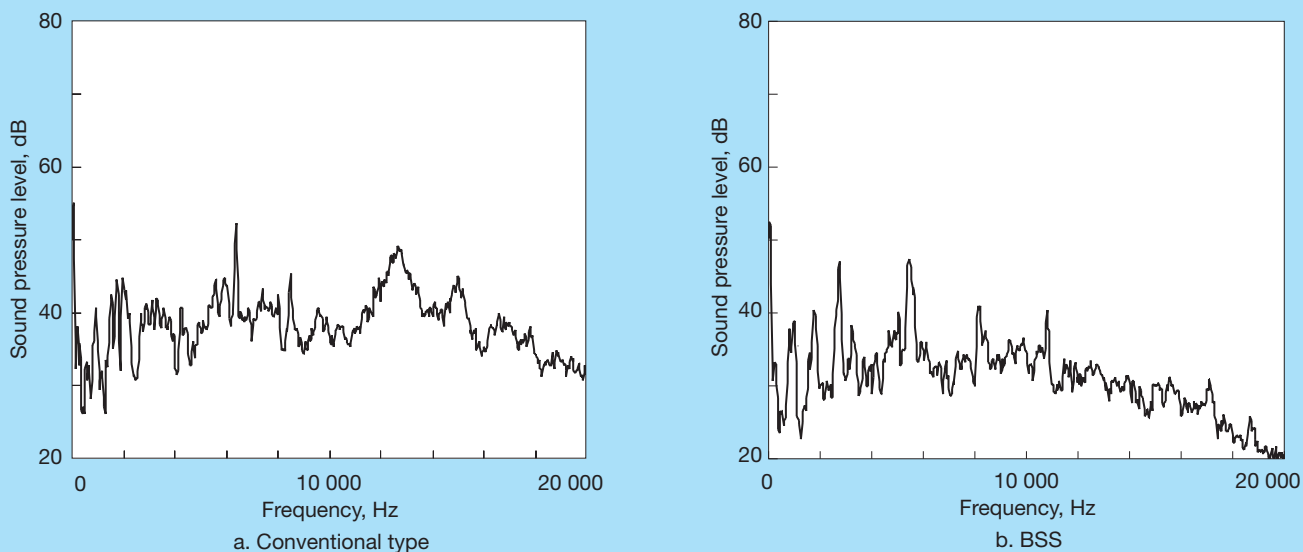

Fig. 3 Comparison data between BSS and conventional type (shaft diameter: 15 mm; lead: 10 mm)

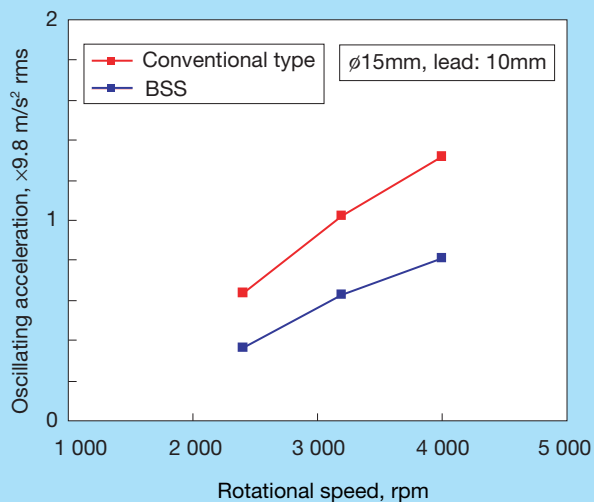

Fig. 4 Comparison of oscillating acceleration (shaft diameter: 15 mm; lead: 10 mm)

the entry point of the unloaded zone to the point at which they change direction, with special consideration for the design of the ball scoop zone (patent pending) as explained in reference 3.

Fig. 3 shows comparison data on noises between BSS and a conventional ball screw. Note the outstanding difference between the two in high-frequency components 3 kHz to 6 kHz or higher. This indicates that noises harsh to human hearing have been effectively reduced and that the BSS has exerted higher effective noise reduction to the

auditory senses than in the values of noise level.

As shown in Fig. 6, the noise level generated by BSS was 65.1 dB/4 000 rpm, which was 6.2 dB lower than the conventional type, which generated 71.3 dB/4 000 rpm. While BSS is reported to be significantly effective in reducing ball circulation noise dominant in medium and large sized ball screws,⁴ it also showed an apparent noise reduction effect for relatively small ball screws of 15 mm in shaft diameter.

Fig. 4 shows comparison data of oscillating acceleration. The oscillating acceleration of BSS was approximately 60% of the conventional type in RMS value.

4. S3 Ball Screw Concept

S3 ball screws reduce pulsating noise even further by adopting ceramic balls with lower mass and control rolling noise by improving the raceway groove accuracy with a special finish based on the previously mentioned standard BSS. Ceramic balls have long been reported to be effective in reducing noise due to the weight reduction of rolling elements. However, using ball screws of conventional specifications at high speed was problematic in that they caused early flaking of ceramic balls, which are brittle components, due to repeated intense collision within the nut. The BSS specification adopted a structure that alleviated ball collision, as mentioned above, enabling for the first time the application of ceramic balls made of brittle materials for ball screws operated at high speeds (patent pending). Further, special considerations need to be given to such factors as impact resistance when selecting ceramic material.

For measures against rolling noise, accuracy of the

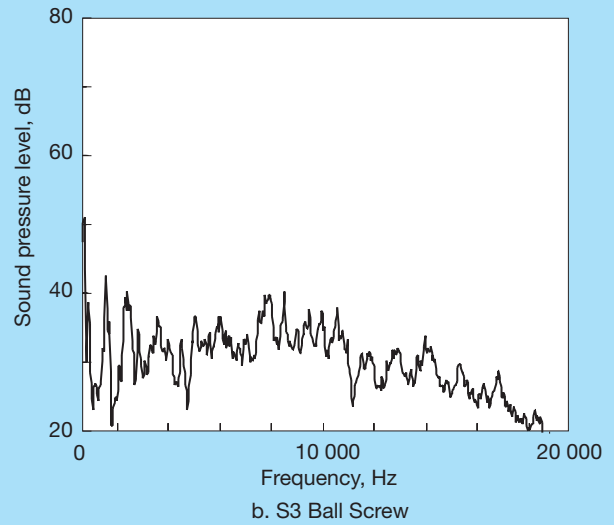
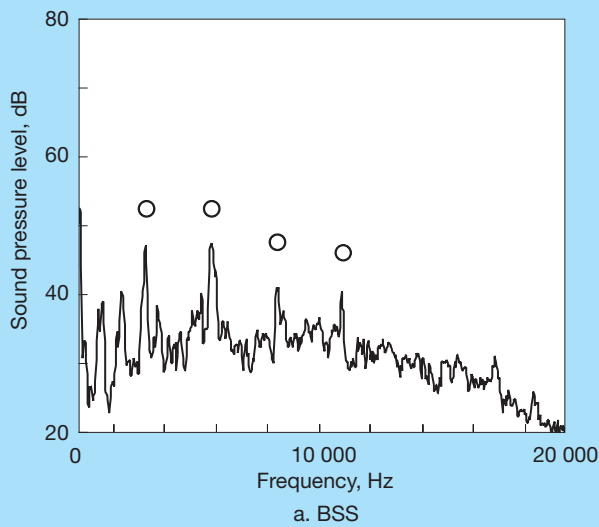

Fig. 5 Comparison of noise between S3 ball screws and BSS series (shaft diameter: 15 mm; lead: 10 mm)

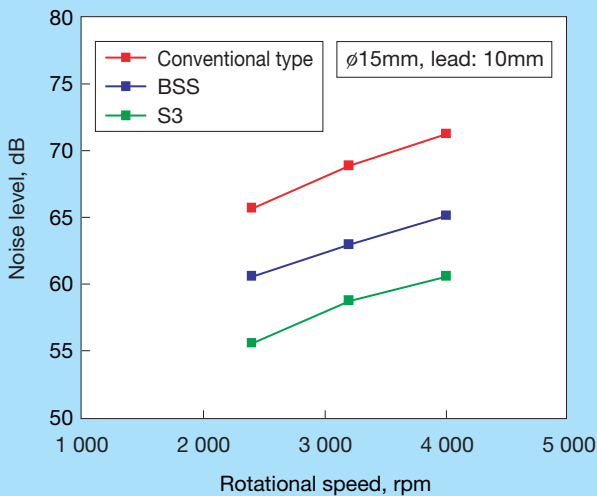

Fig. 6 Comparison of noise levels (shaft diameter: 15 mm; lead: 10 mm)

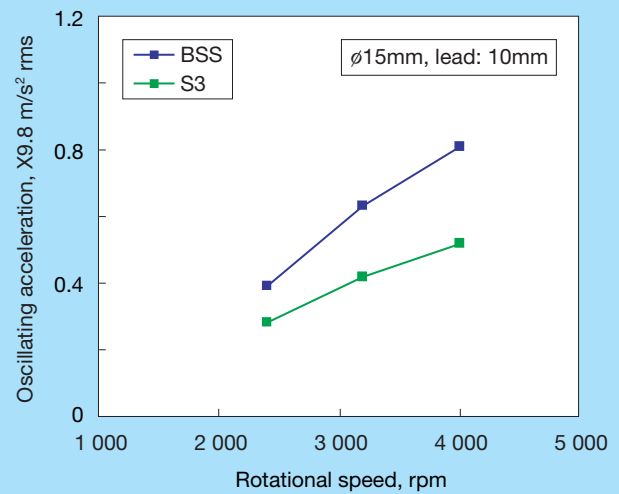

Fig. 7 Comparison of oscillating acceleration (shaft diameter: 15 mm; lead: 10 mm)

raceway groove has to be improved. In principle, periodic inaccuracy in the raceway groove, which results in rolling noise, is more or less inevitable in ground screws with a conventional finish. NSK developed several super-finish processing methods (patented and patent pending) for providing a special finish after conventional screw grinding.

The measures against rolling noise, as designed for S3, in addition to the significant reduction of pulsating noise in BSS, further reduced the noise level.

5. Evaluation of Generated Noise

Fig. 5 compares the noise between S3 ball screws and the BSS series. The circled noise frequencies in Fig. 5, a, have been generated by chatter in the raceway groove. Fig. 5b. indicates the circled noise frequencies generated by rolling noise in 5a. have been eliminated by applying preventative treatment on the raceway groove.

Fig. 6 shows the result of noise level comparisons. Compared with conventional ball screws, while the BSS

reduced individual noise levels by 5 dB to 6 dB, S3 ball screws effected reductions of approximately 10 dB.

Fig. 7 shows comparison data for oscillating acceleration. S3 showed oscillating acceleration on the order of approximately 60 percent of BSS's oscillating acceleration in RMS value.

While the effect of adopting ceramic balls is not self-evident in the data of Fig. 5, the effect becomes clearer at larger ball diameters. Fig. 8 compares noises between S3 ball screws and BSS with ball diameters twice that in Fig.

The circled noise frequencies shown in Fig. 8a. have

been generated by rolling noise in the raceway groove.

In 8b., where preventive treatment was applied against rolling noise, the noise frequencies were eliminated in the same way as those in Fig. 5. When the diameter of the ball is doubled, its volume increases by eight times and pulsating noise increases accordingly. With the ratio of pulsating noise among all noises increased, the adoption of a ceramic ball, which is little less than half the mass of a steel ball, becomes more effective and the noise reduction is more self-evident. Fig. 8 shows high-frequency components of 3 kHz to 6 kHz or higher have been

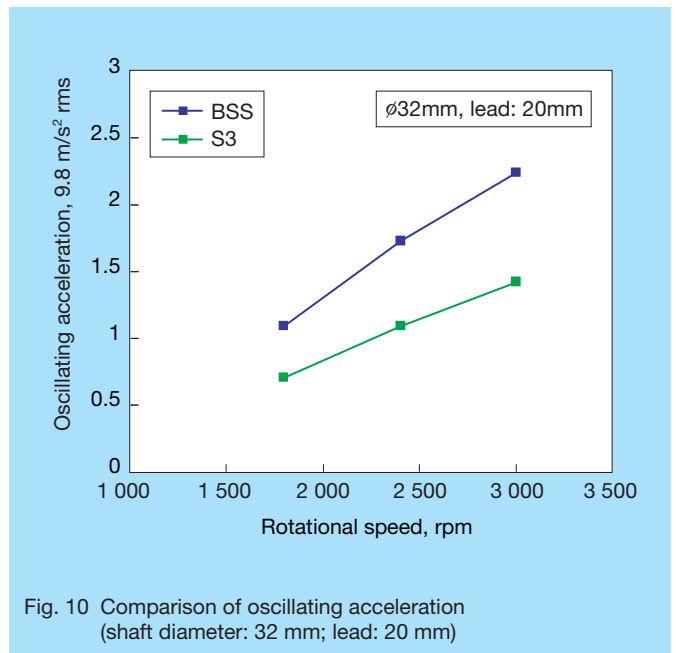
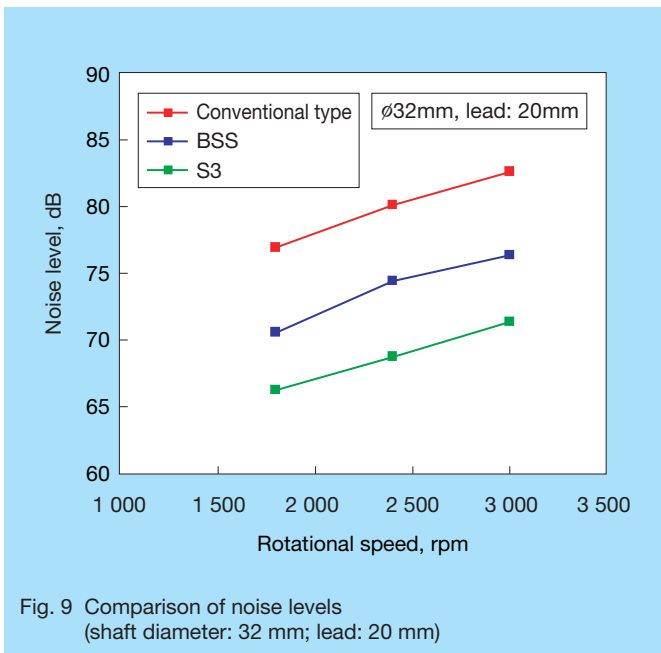
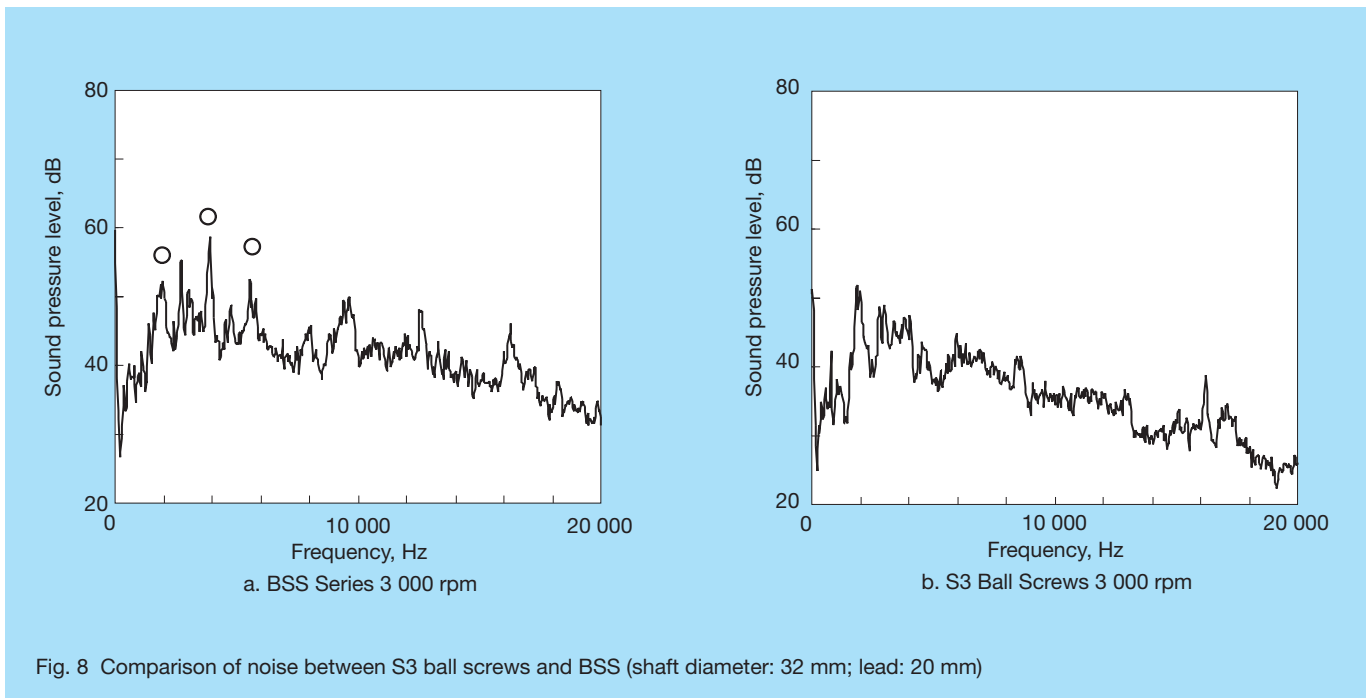

apparently lowered compared with those generated by BSS. In Fig. 8, adoption of a ceramic ball contributed to noise reduction more significantly than a special finish on the shaft groove. Fig. 9 shows a comparison of noise levels in that case. The Fig. indicates BSS reduced the noise level of the value obtained from the empirical formula for conventional types by approximately 6 dB whereas S3 ball screws reduced the noise level by approximately 10 dB.

Fig. 10 shows a comparison of oscillating acceleration. The figure indicates the oscillating acceleration of S3 was on the order of 60 percent or so of that of BSS in RMS value.

6. Conclusion

Although the recirculation method is different from that of BSS, we prototyped a ball screw with a shaft diameter of 20 mm, a lead of 10 mm, and a ball diameter of 3.969 mm in a laboratory environment, incorporating all measures we could think of in addition to special finish processing for nut groove and treatment against ball passage sound. The prototype achieved a noise level of 61.1 dB/4 000 rpm, which is lower than the value calculated from the empirical formula for conventional types, 61.1 dB/4 000 rpm, by 16 dB. This result is approximately 1/6 in comparison to RMS values of oscillating acceleration.

There may be ample opportunity for reducing the various noises generated by ball screws; however, because the type of dominant noise subtly varies depending on such factors as ball screw specifications and operating conditions, it is important to grasp through diagnosis which classification of noise is dominant.

The S3 ball screws that we discussed in this article are designed as ball screws used for automation equipment under high-speed, low-load operating conditions, with shaft diameters between 15 mm to 32 mm and leads between 10 mm to 25 mm, which can reduce the noise level by approximately 10 dB in comparison to conventional ball screws. It is our hope this data will prove helpful to those studying noise reduction of automatic equipment.

References:

- 1) T. Kajita, A. Ishikawa, "Noise Level of Precision Ball Screws," NSK Motion & Control, No. 1, (1996) 37-41.
- 2) T. Igarashi, Y. Tokunaga, K. Ohkuma: "Research on Noise and Vibration of Ball Screws (Part 1, Noise Characteristics of Ball Screws)," Reports (C edition) of Japan Machinist Association, Vol. 54, 499 (1988) 617-622.
- 3) Y. Matsuda, Y. Kagota, M. Taniguchi, "Performance Analysis of High-Speed Low-Noise Ball Screws," Proceedings of 2004 JSPE Spring Conference, A76, (2004) 89-90.
- 4) M. Kato, "Development of High-Speed and Low-Noise Ball Screws," NSK Motion & Control, No. 16, (2004) 22-28.



Toshiharu Kajita



Eiji Hayashi

Development of New Series of Megatorque Motor™ Series for High Speed and Precise Positioning

Yoichi Igarashi, Hirohide Konishi, and Seiichi Kobayashi
NSK Precision Co., Ltd.

ABSTRACT

Direct drive motors must meet increasing demand for higher speeds and strict high-performance requirements. NSK has developed a new Megatorque Motor series that meets such strict requirements for high-speed and high-precision performance of direct drive motors. This article describes an overview of functionality and technologies of the PS series of Megatorque Motor.

1. Introduction

NSK has been marketing direct-drive (DD) motors that directly drive loads under the Megatorque Motor brand name since 1985.^{1,2,3)} The DD motor is free from backlash that tends to be generated by servomotors and speed-reducing systems or mechanical indexes, and facilitates highly accurate, high-speed positioning. In addition to integrated bearings that can directly bear loads, the DD motor works as an actuator that is suitable for applications with compact or space-saving requirements. No additional load-carrying system is required.

When first developed, DD motors generated a great deal of interest for converting industrial robots into direct-drive systems. They were then put into practical use in factory automation and today are widely used in indexing and motion control applications for various industries including assembly lines, inspection lines, and semiconductor, LCD panel, CD, and DVD manufacturing.⁴⁾ They are increasingly recognized as effective actuators for factory automation.

As the fields of application expand, DD motors must deliver greater positioning accuracy for indexing applications that are becoming smaller and lighter, and deliver higher speed positioning in transferring systems for improved production efficiency.

This report discusses the motor technologies of NSK's new PS Megatorque Motor series and a new control system that enables high-speed positioning, and also presents test results of performance needed for actual application of those products.

2. Features of NSK's PS Series

NSK's newly developed PS Megatorque Motor Series (Photo 1) has the following features:

(1) Reduced positioning time

Maximum rotational speed is increased from 3 rps to 10 rps. In addition, settling time to target position is reduced to less than one-fifth that of conventional motors.

(2) Compact, high-torque motor

Optimum magnetic field design with a powerful permanent magnet that enables the motor to generate twice as much thrust per unit of area (thrust density), thereby realizing smaller size and higher torque.

(3) Compact, highly accurate absolute position sensor

The PS series incorporates a resolver that is resistant against adverse environmental conditions for the position sensor that is similar to a conventional motor. An optimized magnetic pole structure reduces the size of the position sensor to two-thirds the size of conventional position sensors and achieves a sensor accuracy of 30 arc seconds (1 arc second = 1 degree/3 600).

(4) Compact driver unit

Combined with a special module, the driver unit body is 35% smaller than conventional units.

Specifications of the Megatorque Motor PS series are shown in Table 1.

3. Development of the PS series

3.1 Development of permanent magnet synchronous motors

3.1.1 Comparison between VR type motor and permanent magnet synchronous motor

Conventional Megatorque Motors use variable reluctance (VR) to generate torque through the switched reluctance of a salient-pole rotor with compact teeth. Multipolarity is easily accomplished without using a magnet by increasing the number of teeth, resulting in high torque generation at low speed. Conversely, grinding is required to maintain a small gap between the rotor and the stator of approximately 0.1 mm.

In a VR motor, since the inductance of the stator coil becomes large, torque characteristics tend to decrease in high-speed areas as the counter electromotive force of the motor increases.⁵⁾

Fig. 1 shows common robotic and transport equipment used in a CD/DVD production line. The transport equipment consists of a stocker for discs and robot that transfers discs between the stocker and the process unit.

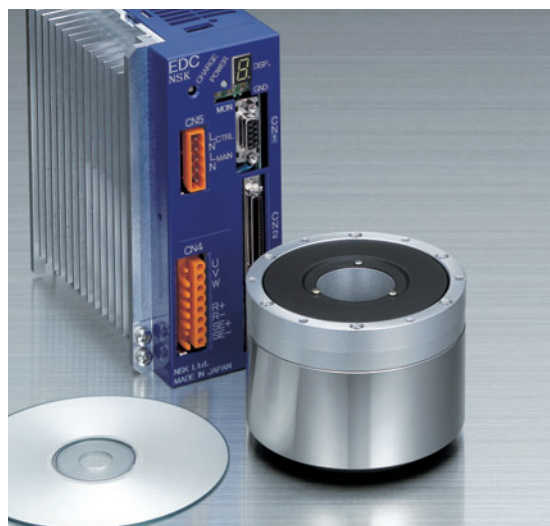

Photo 1 PS series of the Megatorque Motor™

Since transferring devices and stockers contribute no additional value to CDs and DVDs, transfer time must be minimized. In particular, as robot arms often cover large transfer angles of 180° or more, in order to shorten transfer time, maximum rotational speed of the motor must be increased while the space required for the transfer must also be kept as small as possible. Consequently, DD motors must be smaller and capable of higher speeds, features that are difficult to achieve in conventional VR type motors.

Rare-earth magnet Nd₂Fe₁₄B exhibits comparatively higher energy, approximately 320 to 440 kJ/m³, than other permanent magnets. Neodymium magnets, a type of rare-earth magnet, have recently come into use for general-purpose motors as the cost of magnets has come down.⁶⁾

In this context, NSK developed a permanent magnet synchronous Megatorque Motor which supports high-speed rotation.

3.1.2 Design of optimum magnetic pole shape

The design of the motor core took into consideration such factors as torque ripple and cogging torque, which affect high-accuracy positioning, as well as an analysis of magnetic flux density distribution.

The analysis was made by magnetic field analysis using the finite element method (FEM) and verified by actual usage.

In order to evaluate the influence of multiple parameters, a system was constructed to automatically implement a series of design procedures, from listing the major dimensions and elements to preparing the FEM model, inputting conditions, and performing analysis to improve the efficiency of the design. Fig. 2 shows an automatically prepared FEM model and a magnetic flux density distribution chart.

3.1.3 Motor output characteristics

Fig. 3 shows the torque and rotational speed characteristics (N-T characteristic line chart) of PS1006. The figure indicates that the maximum output torque of PS1006 has been increased to twice that of conventional product A and that torque characteristics improved significantly compared with conventional product A and conventional product B (Table 2).

Fig. 4 shows the results of positioning time comparison between PS1006 and conventional types, using the operation of 180° positioning of lightweight material (load inertia: 0.007 kgm²) as an example. The maximum rotational speeds for both conventional products are 3rps. With a maximum rotational speed of 10rps, PS1006 completed positioning in approximately 55% of the time of conventional product A.

The figure indicates that implementation of high-speed positioning requires improvement in maximum rotational speed and higher torque of the motor.

Table 1 Specifications of the PS series of the Megatorque Motor™

Item	Model	PS1006	PS1012	PS1018	PS3015	PS3030	PS3060	PS3090
	Motor outer diameter (mm)		φ100			φ150		
Motor height (mm)		85	110	135	85	102	136	170
Motor bore diameter (mm)		φ35			φ56			
Maximum output torque (N·m)		6	12	18	15	30	60	90
Rated output torque (N·m)		2	4	6	5	10	20	30
Maximum rotational speed (rps)		10			10		8	5
Position sensor resolution (count/rev)		2 621 440			2 621 440			
Absolute positioning accuracy [° (second)]		30			30			
Rotor inertia moment (kg·m ²)		0.0024	0.0031	0.0038	0.011	0.014	0.019	0.024
Motor mass (kg)		2.7	3.8	4.6	6.8	7.7	11.0	13.8

3.2 Development of a new control system

Under the objective of reducing positioning time, NSK has been developing a new version of the control system for the PM linear motor.^{7), 8)} The widespread availability of low-cost, high performance CPUs supports the application of this new control system, which requires high-speed data processing, and therefore NSK incorporated it into the Megatorque Motor.

The reduction of positioning time requires the following:

(1) Increasing rotational speed of the motor

(2) Improving tracking performance of the actual motor against the positioning command during motor operation

(3) Shortening settling time after completion of the positioning command

Requirement (1) is satisfied by a permanent magnet synchronous motor, and requirements (2) and (3) are satisfied through control technologies.

Table 2 Torque and dimensions of PS type and conventional type

	Maximum output torque	Outer diameter	Height
PS1006	6 N·m	φ100 mm	85 mm
Conventional product A	3 N·m	φ100 mm	100 mm
Conventional product B	6 N·m	φ130 mm	100 mm

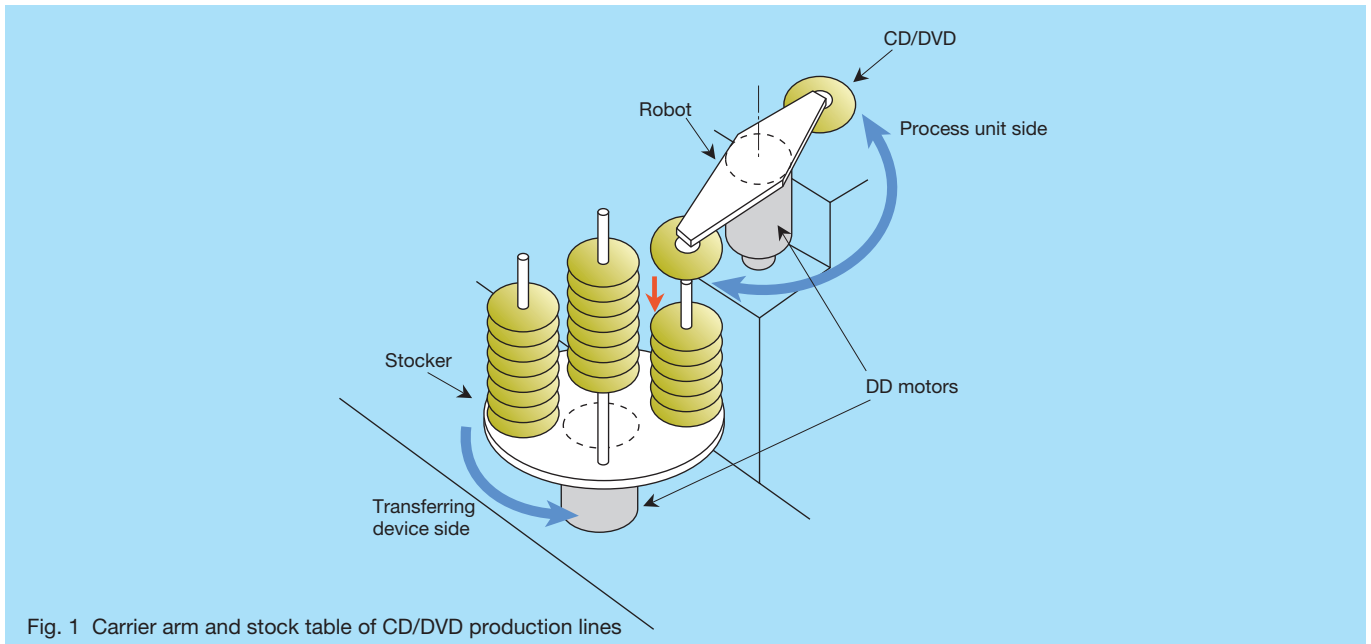

Fig. 1 Carrier arm and stock table of CD/DVD production lines

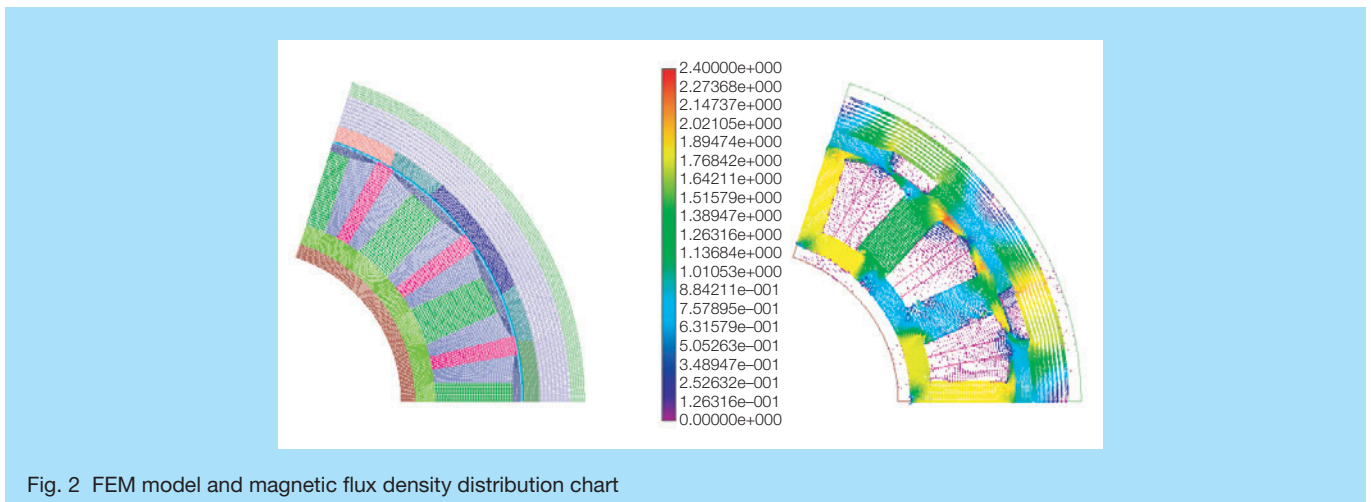
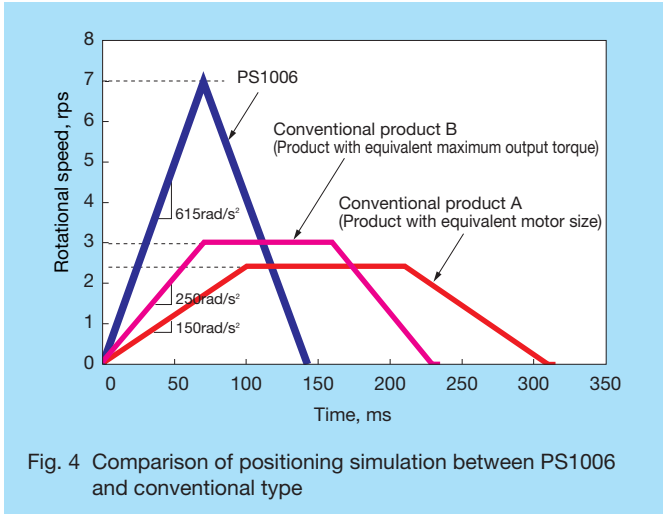
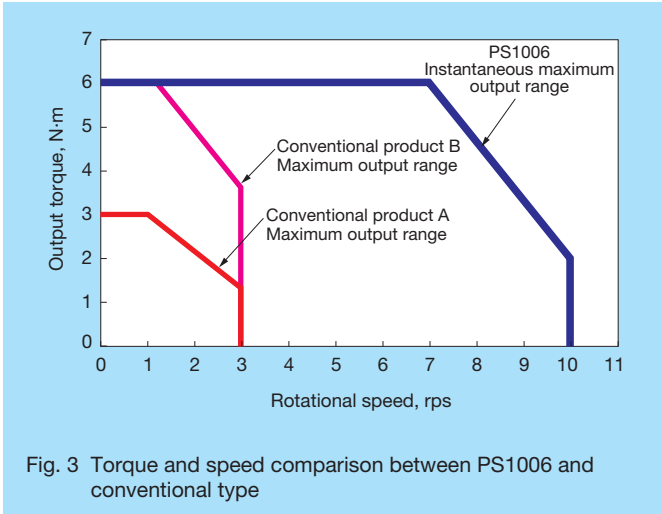

Fig. 2 FEM model and magnetic flux density distribution chart



3.2.1 High-performance tracking controller

In order to enable quicker settling, the tracking error generated during the rotational motion of the motor must be minimized. To that end, we adopted a high-performance tracking controller that compensates for phase lag when receiving the command for positioning to improve responsiveness.

In general, control targets stabilized by feedback control produce phase lag in high frequency domains. In order to enable high-speed positioning motion, there should not be any phase lag during the motion from the target value (positioning command) to the control output (shift amount of the rotational angle of the motor). If phase lag can be compensated by a feedforward controller with the inverse characteristic before compensation by the feedback control system, the transfer characteristic is expected to be “1” and positioning will be realized as commanded.

The zero phase error tracking controller (ZPETC) supports this approach.⁹⁾ Discrete-time modeling $G_{cl}(z^{-1})$ for the control target stabilized by the feedback control system is as follows:

$$G_{cl}(z^{-1}) = \frac{z^{-d} B_c(z^{-1})}{A_c(z^{-1})} \dots\dots\dots (1)$$

where

$$B_c(z^{-1}) = b_{c0} + b_{c1}z^{-1} + \dots + b_{cm}z^{-m}, b_{c0} \neq 0 \dots\dots\dots (2)$$

$$A_c(z^{-1}) = 1 + a_{c1}z^{-1} + \dots + a_{cn}z^{-n} \dots\dots\dots (3)$$

d : dead time
 z^{-1} : delay element

$$B_c(z^{-1}) = B_c^\xi(z^{-1}) \cdot B_c^{u*}(z^{-1}) \dots\dots\dots (4)$$

$B_c^\xi(z^{-1})$: Rational polynomial with stable zeros
 $B_c^{u*}(z^{-1})$: Rational polynomial with unstable zeros

In this case, the output $u(k)$ of the ZPETC, $u(k)$, is expressed as follows:

$$u(k) = \frac{A_c(z^{-1})B_c^{u*}(z^{-1})}{B_c^\xi(z^{-1}) [B_c^\xi(1)]^2} r(k+d+s) \dots\dots\dots (5)$$

where

- s : number of unstable zeros in the closed loop system
- r : desired value
- u : input value to the closed loop system

$$B_c^{u*}(z^{-1}) = b_{cs}^u + b_{c(s-1)}^u z^{-1} + \dots + b_{c0}^u z^{-s} \dots\dots\dots (6)$$

If this equation is applied to the Megatorque Motor with the positioning control loop and the speed control loop stabilized by proportional control, the equation is expressed as follows:

$$u(k) = K \{a_0 r(k+2) + a_1 r(k+1) + a_2 r(k) + a_3 r(k-1)\} \dots\dots\dots (7)$$

Equation (7), which indicates command data from the two sampled sources, must be obtained to prepare the input value into the closed loop system. Here, K and a_0 - a_3 are values determined by the load moment of the motor’s inertia, and gains and constants of the individual loops. In general, because such characteristics are acausal, they are not achievable. However, they become achievable if the motor is equipped with a function for generating a positioning command pulse, since command data can be obtained in advance within the driver unit.

If the above feedforward compensation is made, the transfer function from the commanded target position value to the rotational angle of the motor will be ideally expressed as follows and the motor will have zero phase characteristics:

$$y(k) = \frac{1}{4} \{r(k+1) + 2r(k) + r(k-1)\} \dots\dots\dots (8)$$

Here, if the value of the load moment of inertia that was used in determining the above constant K and a_0 - a_3 deviates from the actual value, the zero phase characteristic cannot be obtained due to the influence of modeling error. To cope with the situation, robustness was ensured by applying the disturbance observer, as explained in the next section, to decrease the influence of the modeling error.

Ideally, the preview feedforward control makes the frequency characteristic from the positioning command of the motor to the rotational angle of the motor as near as possible to the Nyquist frequency, 1. However, it is not necessary to increase the bandwidth to close proximity of the Nyquist frequency to improve the tracking performance of the motor. And if the bandwidth is extended to close proximity of the Nyquist frequency, the tracking performance of the motor may be adversely affected to some extent by such factors as quantizing error in the command in the high frequency domain. Therefore, a zero phase filter that can eliminate only high frequency components without producing a phase lag was applied to eliminate excessive high frequency components without affecting the phase characteristic of the preview feedforward control.

3.2.2 Disturbance observer

In the conventional P-PI method¹⁰⁾, the steady-state deviation caused by such disturbances as friction is kept at zero by providing proportional control in the positioning control loop and providing both proportional control and integral control in the velocity control loop. If integral control is used, then in order to increase integral gain, the gain for proportional control must also be increased at the same time. Insufficient increase in proportional gain determines the upper limit of the integral gain without satisfying the desired elimination of disturbance, resulting in deteriorated control performance or limited shortening of settling.

Therefore, this development effort adopted a disturbance observer to improve disturbance observer (Fig. 5). This control system offsets the influence of disturbances by

estimating a torque disturbance from the torque command to the motor, τ , and the positional output, θ , and compensating for it by feedforwarding through a low-pass filter $Q(s)$.

In this case, the positional output θ is expressed in the following transfer function:

$$\theta = \frac{1}{J_n s^2} \tau - \frac{1-Q(s)}{J_n s^2} \hat{\tau}_d \dots\dots\dots (9)$$

Fig. 6 is a block diagram equivalently converted from Fig. 5.

From Fig. 6, it is seen that the disturbance observer is configured so that the influence of disturbances lower than the cut-off frequency of the low-pass filter $Q(s)$ will be eliminated.

Use of the disturbance observer enables configuration of a control system that is more effective against disturbances than the integral control method, which had been restricted by gains in the velocity control loop. In addition, for these reasons, it can realize settling earlier than previously possible.

4. Results of Positioning Performance Tests

4.1 High-speed positioning test

Fig. 7 shows the comparison of positioning tests resulting between a new and an old Megatorque Motor of the same size. Megatorque Motor JS1003 was used for the conventional product A and PS1006 was used for the new Megatorque Motor. In the positioning motion for 180°, while JS1003 required 330 ms for positioning, PS1006 needed 146.5 ms, less than half the conventional positioning time. In addition, as a result of adopting the newly developed high-performance tracking controller system, PS1006 achieved highly accurate tracking, with the operative deviation amount reduced to an extremely small value of approximately 40 pulses (when the resolution of position sensor was converted to 614 400 count/rev. similar to conventional products), representing 1/500 that of conventional methods.

As for settling time, PS1006 showed a significant reduction of 1 ms against 50 ms of conventional product A.

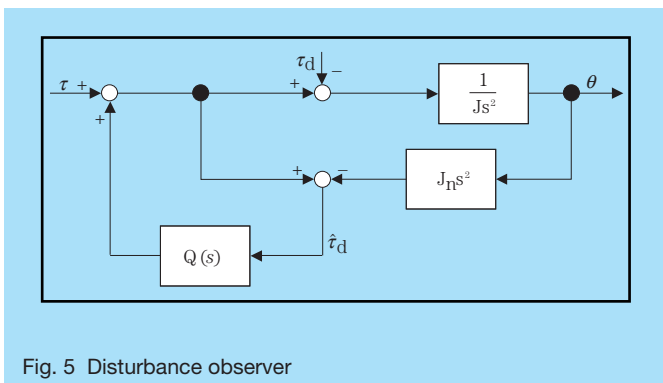

Fig. 5 Disturbance observer

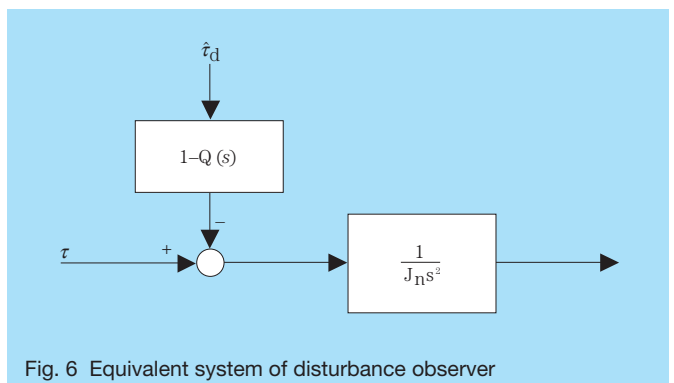
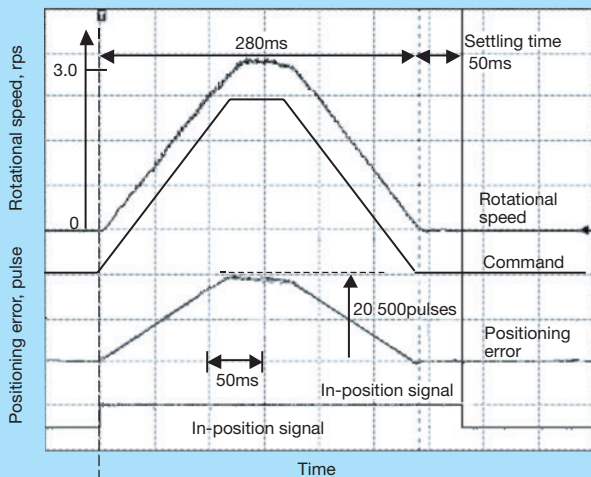
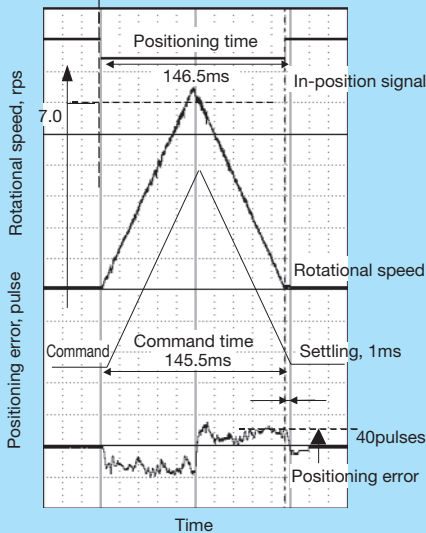

Fig. 6 Equivalent system of disturbance observer



(1) Positioning test rest in JS1003



(2) Positioning test rest in PS1006

Fig. 7 Comparison of positioning test results between JS1003 and PS1006

4.2 High-accuracy positioning (incremental positioning) test

PS series can obtain motor position detection resolution of 2,621,440 counts. Fig. 8 shows the test results of incremental positioning per count. In this test, positioning was made by one count per second clockwise for 10 counts in total, then rotated counterclockwise in the same pattern, and the above motion was repeated. The measurement data was the travel measured at the position 200 mm away from the center of the motor.

This test represents the PS series performed every per-cent movement against 2,621,440 counts without fail, indicating it provides highly accurate positioning.

4.3 Positioning test in low-rigidity load mounting

When a load is mounted on the motor with a thin shaft

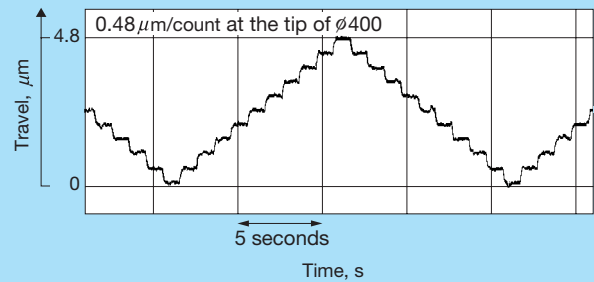

Fig. 8 Incremental positioning test results

or when a low-rigidity load is mounted in an arm-like movement, gain cannot be set as high as when a high-rigidity load is mounted due to the influence of a resonance point.

Measures include the following:

- (1) Dummy inertia is mounted at a position near the motor output shaft and the resonance point is shifted to the side of the anti-resonance point to reduce the influence of the resonance point. In this case, positioning stability can be enhanced with servo gain increased by the load of the dummy inertia mounted on the motor.
- (2) The characteristic of the control target is improved by use of such compensators as a notch filter to lower the gain at the resonance point.

Here, the results are shown of a positioning test against the arm mounted by way of a spline (Photo 2). The frequency characteristic of the test equipment (Fig. 9) is configured with an anti-resonance point at 68 Hz and a resonance point at 260 Hz. The Q -value, which represents the sharpness of the rejection bandwidth, was fixed in the conventional notch filter, but was made freely adjustable in accordance with the characteristic of the applied load within parameters to allow optimum adjustment (Fig. 10).

Fig. 11 shows results of the positioning test for 90° in cases where (1) no countermeasures were taken; (2) dummy inertia was used; and (3) a notch filter was used. In case (1), positioning could not be completed and residual vibration was observed under the influence of a

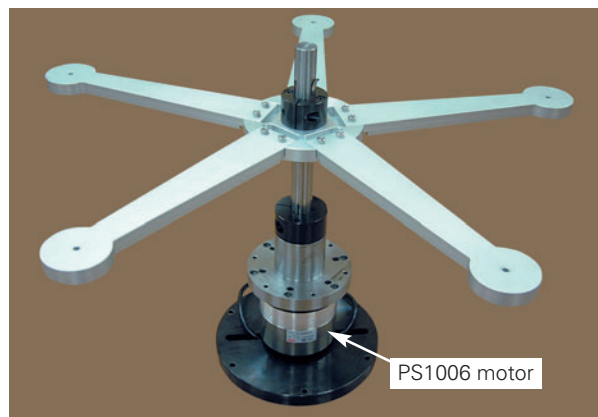

Photo 2 Test rig using low-rigidity arms

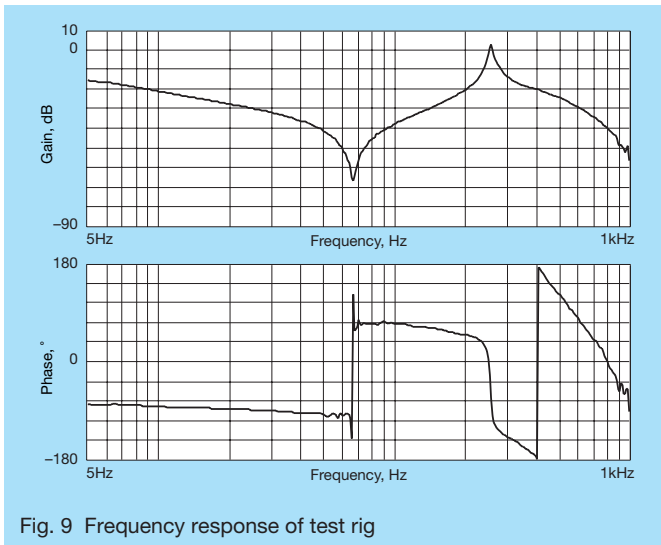

Fig. 9 Frequency response of test rig

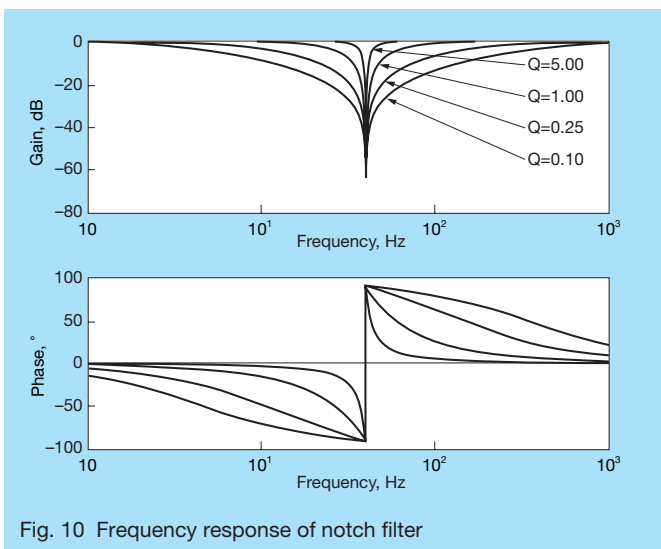

Fig. 10 Frequency response of notch filter

resonance frequency. Both in the case where dummy inertia was mounted and in the case where the gain at the resonance point was lowered by a notch filter, positioning was completed with very little residual vibration. In the case where compensation was made by a notch filter, positioning was completed in a shorter time than in the case where dummy inertia was mounted because acceleration/deceleration can be set higher in the former case under the influence of the moment of inertia.

5. Conclusion

This report discussed and introduced technologies used in the new PS Megatorque Motor series for high speed and accurate positioning. NSK is determined to continuously develop new technologies and products for making DD motors easier to use as actuators in factory automation and to expand the range of applications by meeting various requests and expectations for DD motors.

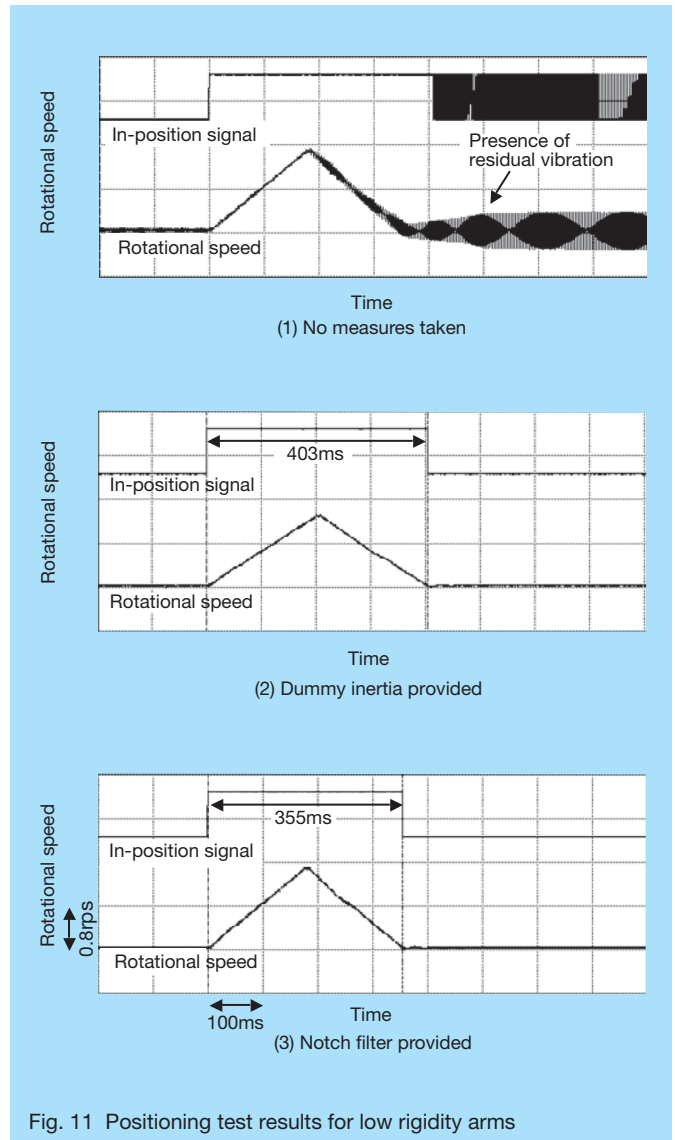

Fig. 11 Positioning test results for low rigidity arms

References:

- 1) Tadao Inomata, "Megatorque Motor," NSK Technical Journal, 649 (1991) 37-44
- 2) Tadao Inomata, "Direct Drive Technology," Study of Machines, No. 1, Vol. 44(1992) 117-122
- 3) Yoshiharu Yamaguchi, "Megatorque Motor as Actuator for Robots," The Journal of the Institute of Electrical Engineers of Japan (1987), No. 10, Vol. 107, 1023-1026
- 4) Seiichi Kobayashi, "Application of Direct Drive Motors," Design Engineering, 37-3, (2002) 311-317.
- 5) Takashi Kenjo, "Ultrasonic Motor for Electronic Devices," Sogo Denshi Shuppan, (1977) 135
- 6) Ryo Kikuchi, Shigeho Tanigawa, "Higher Performance of Rare-Earth Magnets," Hitachi Metals Technical Review, 15, (1999) 111-114.
- 7) Seiichi Kobayashi, Carl J. Kempf, "Disturbance Observer and Preview Feedforward Position Controller Design for a Wire Bonding Table," NSK Technical Journal, 664 (1997) 46-58.
- 8) Carl J. Kempf, Seiichi Kobayashi, "Disturbance Observer and Feedforward Design for a High-Speed Direct-Drive Positioning

Table,” IEEE Transaction Control Systems Technology, 7-5 (1999) 513–525.

9) Tomizuka, M., “Zero Phase Error Tracking Algorithm for Digital Control”, ASME Journal of Dynamic Systems, Measurement, and Control, 109 (1987) 65–68.

10) Hiroshi Sawada, Seiichi Kobayashi, “Control of Direct Drive Motors,” NSK Technical Journal, 653 (1992) 42–49.



Yoichi Igarashi



Hirohide Konishi



Seiichi Kobayashi

Long Life Roll Neck Bearings for Steel Rolling Mills—WTF™ Bearings

Iron and steel works use various rolling mill equipment including hot rolling mills and cold rolling mills. A typical four-high rolling mill consists of a work roll and a backup roll, while a six-high rolling mill will include an additional intermediate roll.

Four-row tapered roller bearings are widely used in both work rolls and intermediate rolls. These roll neck bearings are faced with extremely harsh operating conditions that adversely affect bearing life. The operating environment includes vibration, impact loads, and insufficient lubrication as a result of water-infiltrated grease lubrication and contamination.

Since 1995, NSK has continually focused efforts on research and development for long-life bearing material. In 1999, NSK developed the Extra Capacity Sealed-Clean™ roll neck bearings that incorporated a seal for dramatically improving performance as a measure against ingress of water and iron oxide debris. These roll neck bearings also offer higher load capacity and have been well received by customers in the iron and steel works industry. Our continued efforts towards achieving long bearing life under water-infiltrated grease lubrication and iron oxide contaminated conditions have resulted in the development of NSK's Water-Tough (WTF) bearings (Photo 1).

1. Features

WTF bearings offer long-life even under water-infiltrated lubricant and foreign particles.

WTF bearings are made from super-clean bearing steel developed by taking full advantage of NSK's design

technology expertise, and by subjecting the material to a proprietary heat treatment process. This new material significantly enhances bearing life under water-infiltrated grease lubrication. Features of WTF bearing material include:

- A. A process to ensure higher steel cleanliness is applied to the bearing material to inhibit early-stage fatigue crack generation, which can lead to flaking.
- B. An optimum alloy balance ensures a stronger grain boundary, which is effective in preventing fatigue/crack propagation at stress fields in the steel.

NSK's proprietary TF technology includes a heat treatment process that controls the surface retained austenite content, which is effective in extending bearing life even under contaminated conditions of foreign particles. Fig. 1 illustrates the results of tests conducted with WTF bearings in an actual rolling mill. In comparison to conventional bearings, NSK's WTF bearings achieved a service life

that was three times longer.

2. Specifications

WTF bearing specifications include the same advantages and strengths of our Extra Capacity Sealed-Clean roll neck bearings. Fig. 2 illustrates an example of WTF bearing dimensions, and Table 1 lists specifications for several WTF bearing numbers.



Photo 1 WTF™ bearings

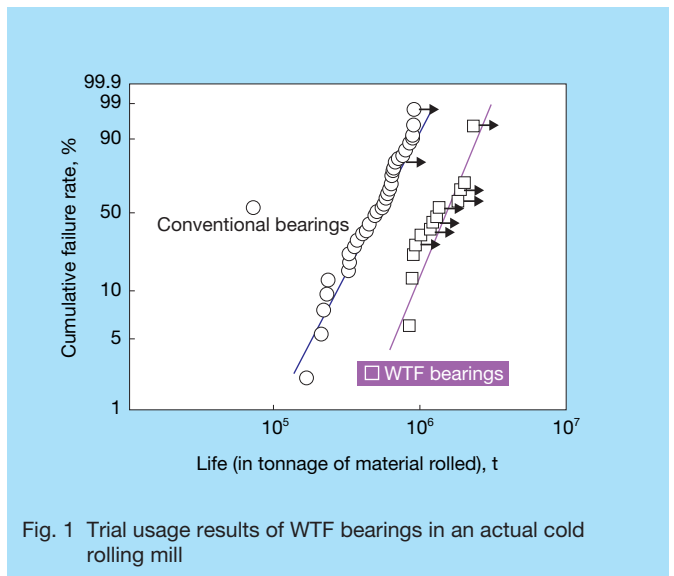

Fig. 1 Trial usage results of WTF bearings in an actual cold rolling mill

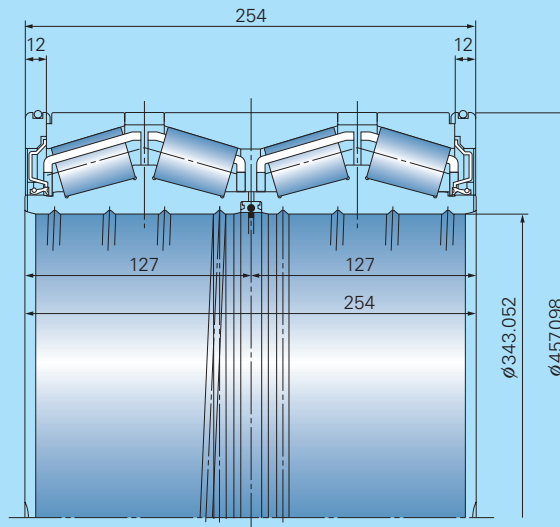

Fig. 2 Dimensions of WTF bearings (example)

Table 1 Specifications of WTF bearings (example)

Bearing number	Bearing size (bore diameter, outside diameter, width) mm	Basic load rating, kN
WTF254KVS3551E	$\phi 254 \times \phi 358.775 \times 269.875$	2 070
WTF276KVS3951E	$\phi 276.225 \times \phi 393.7 \times 269.875$	2 330
WTF343KVS4551E	$\phi 343.052 \times \phi 457.098 \times 254$	2 430
WTF482KVS6151E	$\phi 482.6 \times \phi 615.95 \times 330.2$	4 200

3. Application Examples

Work rolls and intermediate rolls of hot rolling mills and cold rolling mills for iron and steel works are the targeted applications for our WTF bearings. Additionally, by adopting WTF bearings, extending operating life of mills is promising even under severe conditions such as water-infiltrated grease lubrication and contamination from iron oxide debris.

4. Summary

WTF bearings are best suited for harsh operating conditions including rolling mills for iron and steel works. The enhanced service life offered by WTF bearings will help customers in the iron and steel works industry to reduce downtime and maintenance costs.

Sensor Bearings for General Industrial Machinery

Demand is growing in recent years for industrial machinery and equipment that offer higher efficiency and greater functionality in a more compact design.

To meet the growing demand, NSK has developed sensor bearing that integrates sensing functions for axial rotating speed and rotational direction in a compact design.

1. Structure and Specifications

Photo 1 shows a sensor bearing for general industrial machinery. Fig. 1 illustrates the bearing's electrical circuit, while Table 1 lists the bearing's specifications.

NSK has combined a deep groove ball bearing with the sensor to create a unitized structure. When the inner ring rotates, two pulse signals with a phase shift of 90 degrees are output (Fig. 2).

2. Features

- A. Rotational speed & direction are simultaneously detectible.
- B. The unitized structure of the sensor and bearing allows for an improved assembly process and enhances further downscaling of equipment.
- C. Using an active sensor, phase detection over a wide range of speeds is possible.

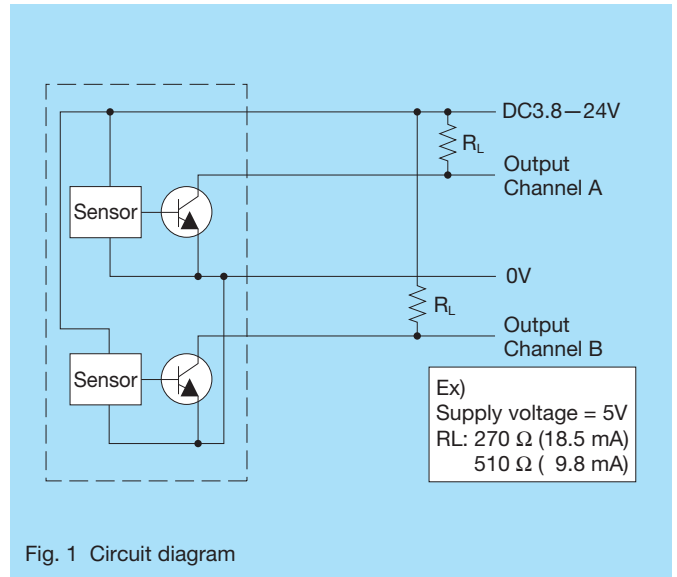

Fig. 1 Circuit diagram

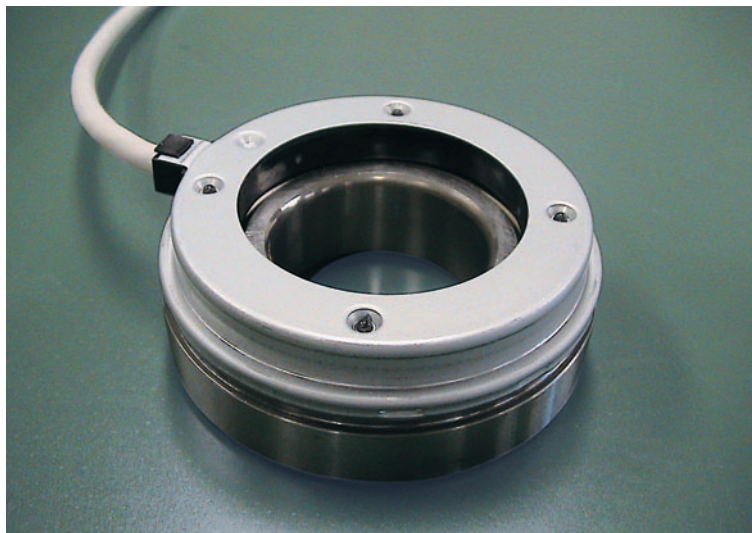

Photo 1 Sensor bearing

Table 1 Specifications

Items	Details
Bearing	Deep groove ball bearing 6206
Dimensions	Bore diameter: 30 mm / Outer diameter: 62 mm / Width: 23.5 mm
Number of pulses	64/rev.
Output pulse	Channel A and channel B (Phase shift: 90 degrees \pm 45 degrees)
Pitch accuracy	\pm 5 %
Duty ratio	50 % \pm 15 % (35 % to 65 %)
Input power	3.8 to 24 V
Output current	Less than 20 mA
Operating temperatures	-40°C to 120°C

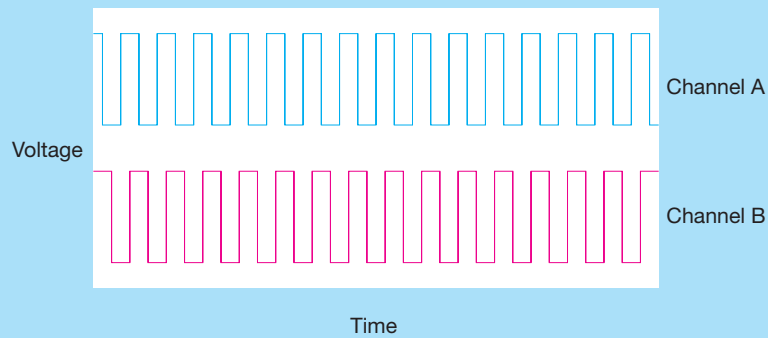

Fig. 2 Example of output signals

3. Applications

The following is a short list of major applications of NSK's sensor bearing that require control of rotational speed or rotational direction:

- Washing machines
- Robots
- Forklifts
- Power wheelchairs
- Elevators (freight and passenger)

4. Summary

NSK's sensor bearing has been developed to meet the needs of the market by providing various applications with higher efficiency and greater functionality in a compact design.

Long-Term Maintenance-Free Ball Bearings for Railway Traction Motors

Operating conditions of bearings used in railway traction motors continue to be extremely harsh. Since the 1980s, Japan's railway industry has been adopting variable-voltage, variable-frequency (VVVF) inverter control systems. A growing trend points to the use of alternate current (AC) traction motors, which although are more compact than conventional direct current motors, must be able to operate sufficiently under high-speed and high-temperature running conditions.

A March 2002 revision to a Japanese transportation ministry ordinance allows railway companies to determine the details of periodic inspections. This approach has resulted in the need for bearings with increasingly long-term maintenance-free performance.

Traction motor bearings operate under conditions that include high running speeds, rapid acceleration and

deceleration, light loads, and grease lubrication.

Maintaining a sufficient amount of lubricant is key to ensuring the long-term maintenance-free performance of the bearings; especially ensuring a stable oil supply to the cage pockets where rolling elements make direct contact with the cage is essential.

NSK has developed a new type of bearing with a machined ball-guided cage that responds to the demands for long-term maintenance-free performance (Photo 1). Features and the structure of this new product are discussed in this article.

1. Structure

Fig. 1 shows cross section views of the new type of bearing and a conventional bearing. Features of the cage for the new bearing include the following:

- 1) Ball-guided cage for superior lubricating performance
- 2) Specially configured cage pockets for excellent wear resistance
- 3) Large cage bore for retaining large amounts of grease (Fig. 2)
- 4) Retained amount of grease remains high regardless of running speed (Fig. 3). Stable grease supply is ensured under high-speed operations.
- 5) Highly accurate and wear-resistant machined cage

2. Capability

- 1) Wear-resistant cage extends service life

Cage durability has been improved by optimizing cage specifications in the new bearing for improving lubricating conditions of the cage pocket. This results in favorable lubricating conditions for an extended period of time, thus enabling longer bearing service life than that of conventional bearings (Fig. 4).

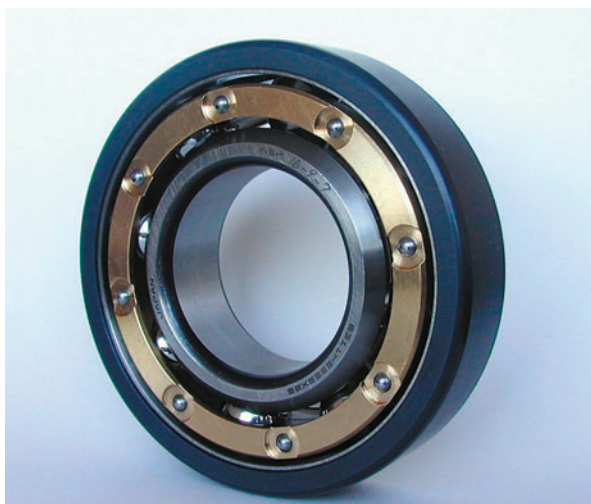

Photo 1 Long-term maintenance-free ball bearings for railway traction motors

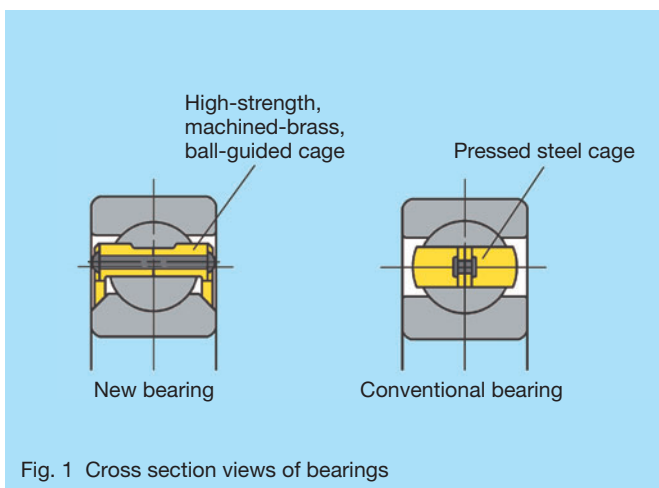

Fig. 1 Cross section views of bearings

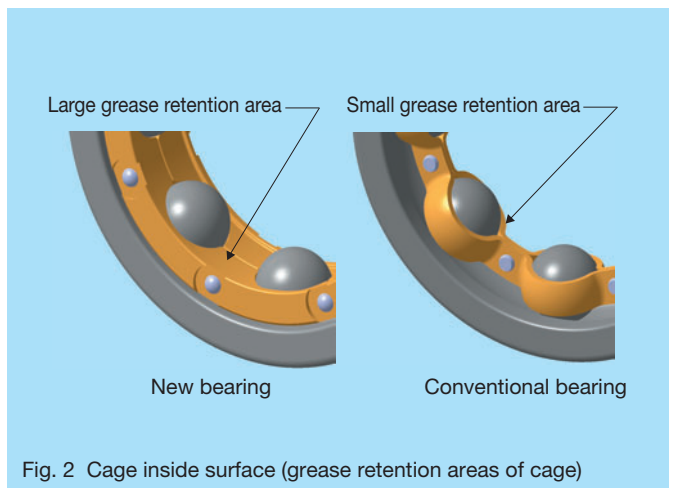

Fig. 2 Cage inside surface (grease retention areas of cage)

2) Highly reliable and safe

The cage has a fail-safe design that allows the outer ring to guide the cage in the event that the cage pockets become excessively worn due to improper guiding by the balls as a result of improper lubricating conditions caused by electrical corrosion or foreign particle contamination.

3) Shock resistant

The cage is highly resistant against shock load conditions, and rapid acceleration and deceleration.

3. Summary

NSK's new ball bearing with a ball-guided machined cage achieves long-term maintenance-free performance to meet the needs of railway traction motors that operate under high-speed conditions, which include rapid acceleration and deceleration. Extended maintenance-free performance can be further enhanced by taking measures against electric corrosion for this new type of bearing and by adopting long-life grease. NSK will continue to work on new developments that respond to the needs of the railway industry.

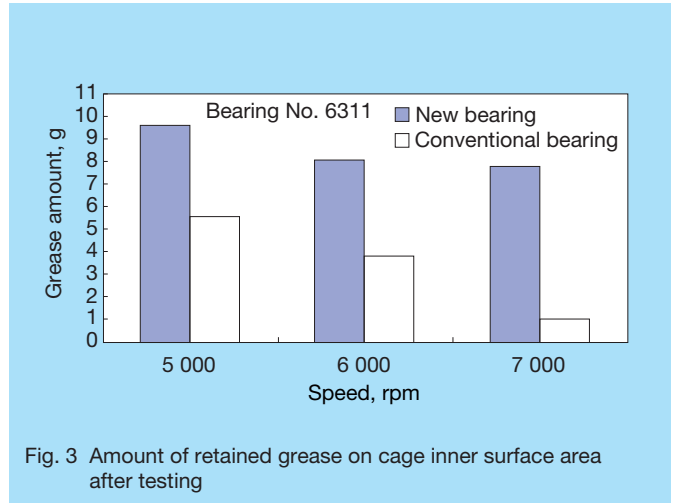

Fig. 3 Amount of retained grease on cage inner surface area after testing

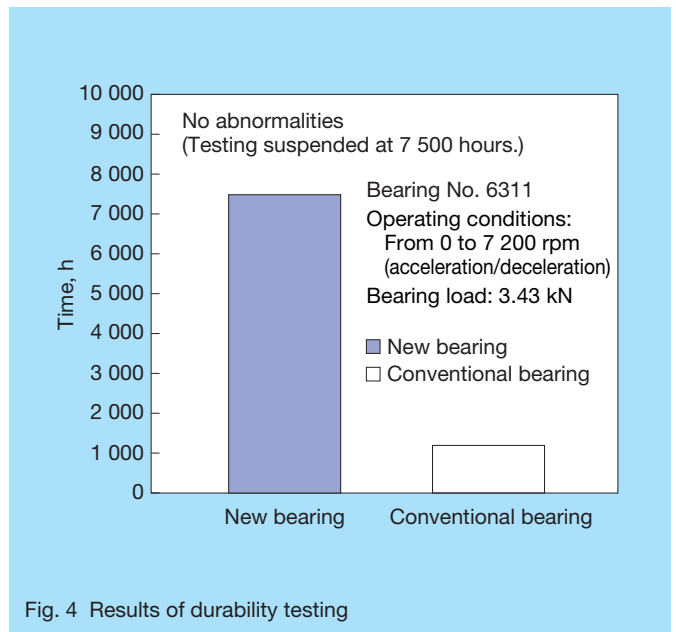

Fig. 4 Results of durability testing

Ultra-Precision Bearings for Precision Machine Tools—Robust™ P2X Series

Machine tool makers have been developing value-added machine tools with higher functionality to differentiate their products from the competition. They have especially focused on greater accuracy of lathes and molding machines. Examples include precision lathes for manufacturing parts of fluid dynamic bearing (FDB) spindle motors and photoconductive drums, and high-precision machining centers aiming to improve the surface quality and extend the life of extra fine cutters. The level of accuracy required for these machine tools is so high that conventional ISO Class 2 bearings are unable to ensure sufficient accuracy. Therefore, NSK has responded to the need for special control by using bearings with a higher degree of accuracy than that of ISO Class 2 by developing a new series of ultra-precision bearings, the Robust P2X series (Photo 1). This article describes the Robust P2X series in greater detail.

1. Features

1.1 Ultra-precision that is superior to the ISO standard

While dimension accuracy is equivalent to ISO Class 2, these bearings exhibit better than ISO Class 2 running accuracy performance.

1.2 Control of overall shaft runout

We have controlled running accuracy based on ISO standards and total error motion value as well (based on non-repeatable runout). (Regarding shaft displacement, refer to Fig. 1.)



Photo 1 Ultra-precision bearings

2. Capability

2.1 Precision lathe spindles

Precision lathe spindles require an outer diameter roundness of the machined workpiece to be 0.2 μm or less. Fig. 2 shows the evaluation results of outer diameter roundness of a precision lathe equipped with angular contact ball bearings, which achieved an outer diameter roundness of the machined workpiece of 0.1 μm to 0.2 μm (angular contact ball bearings: bore diameter 50 mm x outer diameter 80 mm, 3 000 rpm).

We conducted the same evaluation for a precision lathe equipped with cylindrical roller bearings. Fig. 3 shows the evaluation results of outer diameter roundness of the machined workpiece, which ranged from 0.1 μm to 0.3 μm (cylindrical roller bearing: bore diameter 100 mm x outer diameter 150 mm, 4 000 rpm).

2.2 High-precision machining center

Molding machine spindles require a running accuracy of at least 5 μm for the bearing positioned 300 mm from the fixed side. We measured the running accuracy of a Robust P2X series bearing (Photo 2) positioned 300 mm from the fixed side and accomplished a running accuracy of at least 5 μm (angular contact ball bearings: bore diameter 70 mm x outer diameter 100 mm).

3. Specifications

The rolling elements of this series consist of ceramic balls for the angular contact ball bearings and high-precision rollers for the robust cylindrical roller bearings.

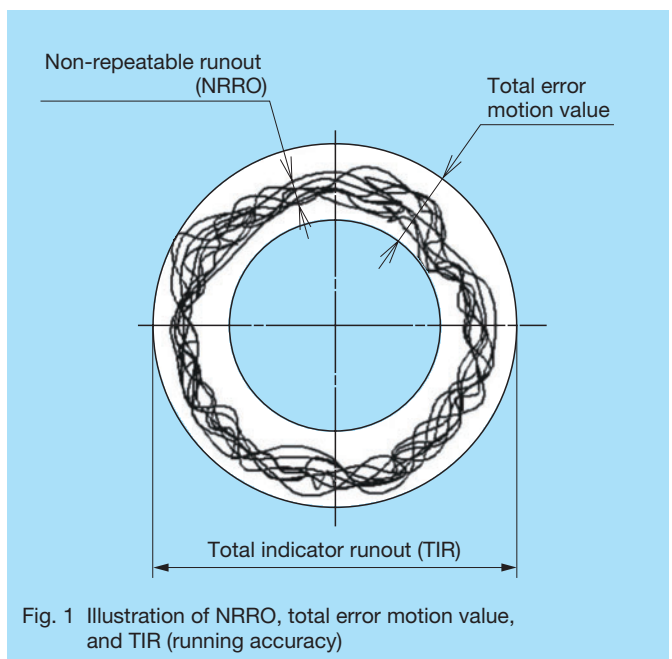

Fig. 1 Illustration of NRRO, total error motion value, and TIR (running accuracy)

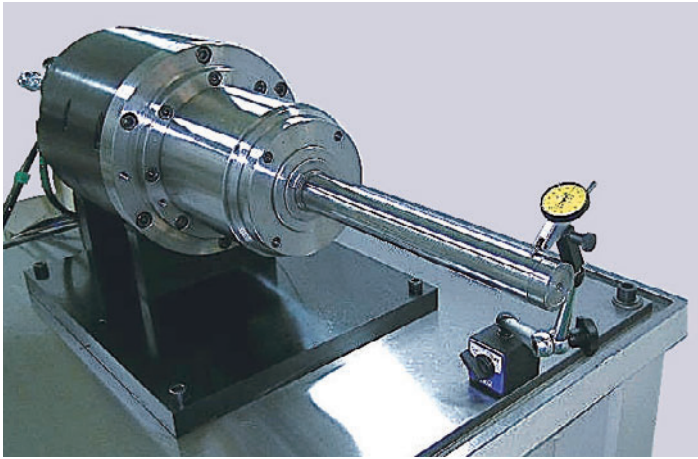
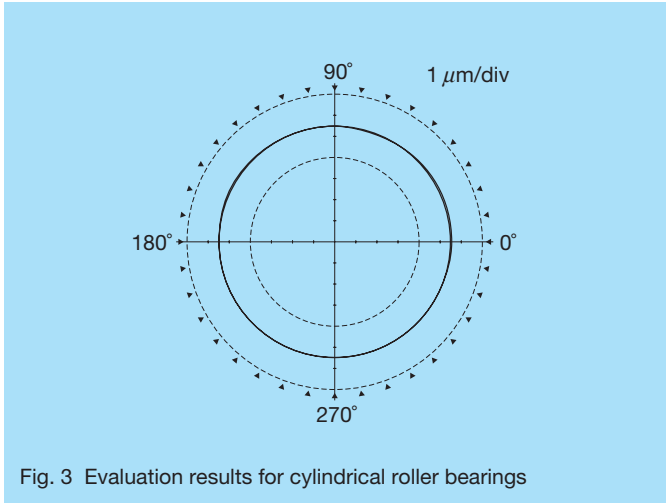
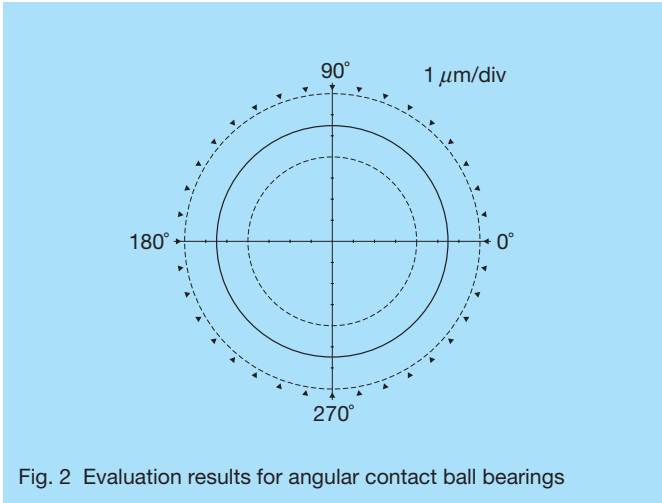

Photo 2 Runout measuring equipment

Table 1 Specifications of the Robust P2X series

Type	Variations	Dimension series	Bearing bore diameter
Angular contact ball bearing	Contact angle 18°	BNR10, BNR19	ø30—ø130
	Contact angle 25°	BER10, BER19	
Cylindrical roller bearing	Single row	N10XXR	ø45—ø85
	Double row	NN30XX	

A newly designed low-vibration cage has also been adopted. Bore diameter ranges from 30 mm to 130 mm for the angular contact ball bearings, and from 45 mm to 85 mm for the cylindrical roller bearings (Table 1).

4. Applications

This new series ensures high running accuracy precision of lathe machine spindles (for manufacturing parts for FDB spindle motors and photoconductive drums) and machining center spindles (for precision molding machines).

5. Summary

Requests for high accuracy and high-quality processing performance from the machine tool industry will become stricter and the demands placed on the Robust P2X series will continue to grow. NSK will focus on furthering advanced running accuracy performance of angular contact ball bearings and cylindrical roller bearings.

Miniature Monocarrier™ MCM02

As low-cost competition intensifies, production systems are turning to laborsaving measures and automation to improve efficiency. The NSK Monocarrier series of single-axis actuators, which combines a ball screw, linear guide, and ball screw support units, has contributed to achieving greater efficiency. The space-saving integration of components makes this series of actuator suitable for a wide variety of applications, including assembly, inspection, packaging, and transportation.

In addition, there is increasing demand for lightweight and compact equipment. In order to meet these needs, and to assist designers in developing new applications, NSK developed the Monocarrier MCM02 (Photo 1), featuring a rail width of 28 mm, and a more lightweight and compact design compared to conventional models.

1. Features

1) Lightweight and compact

The distinguishing characteristics of Monocarrier MCM02 are its lightweight and compact size. Table 1 lists the main specifications, and Figure 1 provides a comparison with NSK's miniature Monocarrier MCM03.

2) Simplified design and installation

The ball screw, linear guide, and ball screw support units are fully integrated into one unit to dramatically reduce initial design work of user applications and installation time of the actuator.

3) Excellent corrosion resistance

Standard low-temperature chrome plating on the rails and the sliders prevents corrosion.

4) Maintenance-free performance

The Monocarrier is equipped with NSK K1™ lubrication units as a standard feature for long-term, maintenance-free performance.

5) Wide selection of options

The following items can save application designers time and effort:

- Cover unit
- Sensor unit
- Motor bracket

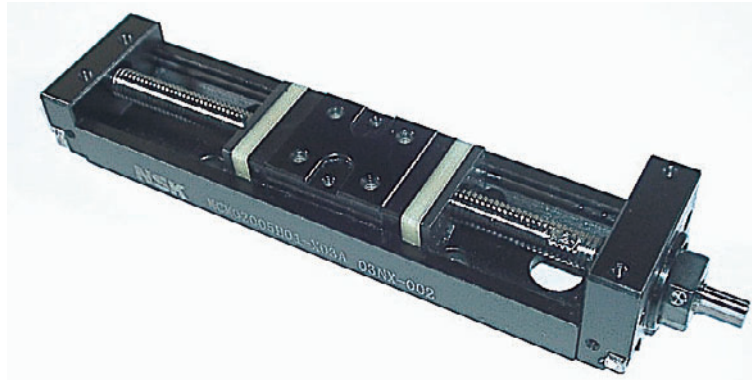

Photo 1 Monocarrier™ MCM02

Table 1 Monocarrier™ MCM02 specifications

Stroke (mm)	Ball screw shaft diameter (mm)	Ball screw lead (mm)	Body length (rail length) (mm)	Mass (kg)
50	6	1 or 2	128.5 (100)	0.26
100			178.5 (150)	0.32
150			228.5 (200)	0.39

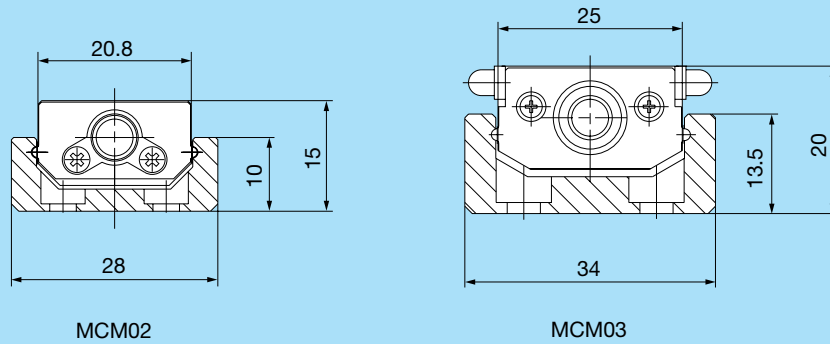

Fig. 1 Comparison of section dimensions

2. Applications

Like NSK's conventional models, the MCM02 is suitable for inspection, packaging, and assembly line equipment, and measuring devices. In addition, its smaller size supports a wide range of applications, including medical equipment and diagnostic instruments.

New Generation of NSK Linear Guides Miniature PU Series/PE Series

The NSK Miniature Linear Guides are widely used in such cutting-edge applications as semiconductor and liquid crystal display manufacturing equipment that require fine and accurate positioning. The Miniature PU Series, which were first introduced in the May 2003 issue of Motion & Control, is a new generation of miniature linear guides, featuring a lightweight design and higher functionality than our conventional miniature series. These improvements were achieved by introducing resin components into a newly designed ball recirculating circuit.

NSK has developed and marketed the Miniature PE Series as a new product ideal for wide, single-rail applications and has upgraded the Miniature PU Series. This upgrade of the Miniature Linear Guides also includes the introduction of interchangeable types of both series that allow random matching of rails and ball slides. Features of both series are further described below.

1. Features

The Miniature PU Series and PE Series (Photo 1) offer users the following features:

- (1) Lightweight
The ball slide body is approximately 20% lighter than that of conventional NSK models by fabricating the recirculation component out of molded resin material.
- (2) High corrosion resistance
The rail, ball slide body, and balls are made of highly corrosion-resistant martensite stainless steel.



Photo 1 Miniature PU series/PE series

- (3) Excellent dust resistance
Minimized clearance between the side faces of the rail and the inner wall of the ball slide in its lower part, resulting from highly accurate dimension control of the rail and the ball slide, works as a bottom seal with lower friction for superior dust resistance.
- (4) Easy handling
The user-friendly design includes a retainer that prevents balls from dropping out of the ball slide even when the slide is removed from the rail for ease of handling and installation.
- (5) Long-term, maintenance-free performance
These linear guides can be equipped with NSK K1™ lubrication units for long-term, maintenance-free use.
- (6) Standard and wide rail sizes
In addition to the PU Series standard rail dimensions, the PE Series is available for wide rail applications. The PE Series also provides users with high moment load capacity for single-rail applications.
- (7) Interchangeability
We have also introduced interchangeable types that enable random matching of rails and ball slides. This feature lets us stock the rails and the ball slides respectively, thus making faster deliveries of each assembly to the field, where customers can more easily expand production lines or make modifications to individual manufacturing equipment.
The maximum radial-clearance of rails and ball slides has also been reduced from the conventional specification of 15 μm to 3 μm for greater precision in movement.

2. Shape and Dimension

The shapes and dimensions of rails and ball slides of the PU Series and PE series are shown in Table 1.

3. Accuracy and Preload

- (1) Preloaded assembly
Four accuracy grades available: super precision grade P4, high precision grade P5, precision grade P6, and normal grade PN. In addition, two preload levels are available: slight preload (Z1) and fine clearance (Z0).
- (2) Interchangeable types
An accuracy grade of normal (PC) and a preload level of fine clearance (ZT) are also available.

4. Applications

Suitable for semiconductor and liquid crystal display manufacturing equipment, printed circuit board manufacturing equipment, medical devices, and various precision stages.

Table 1 Standard dimensions

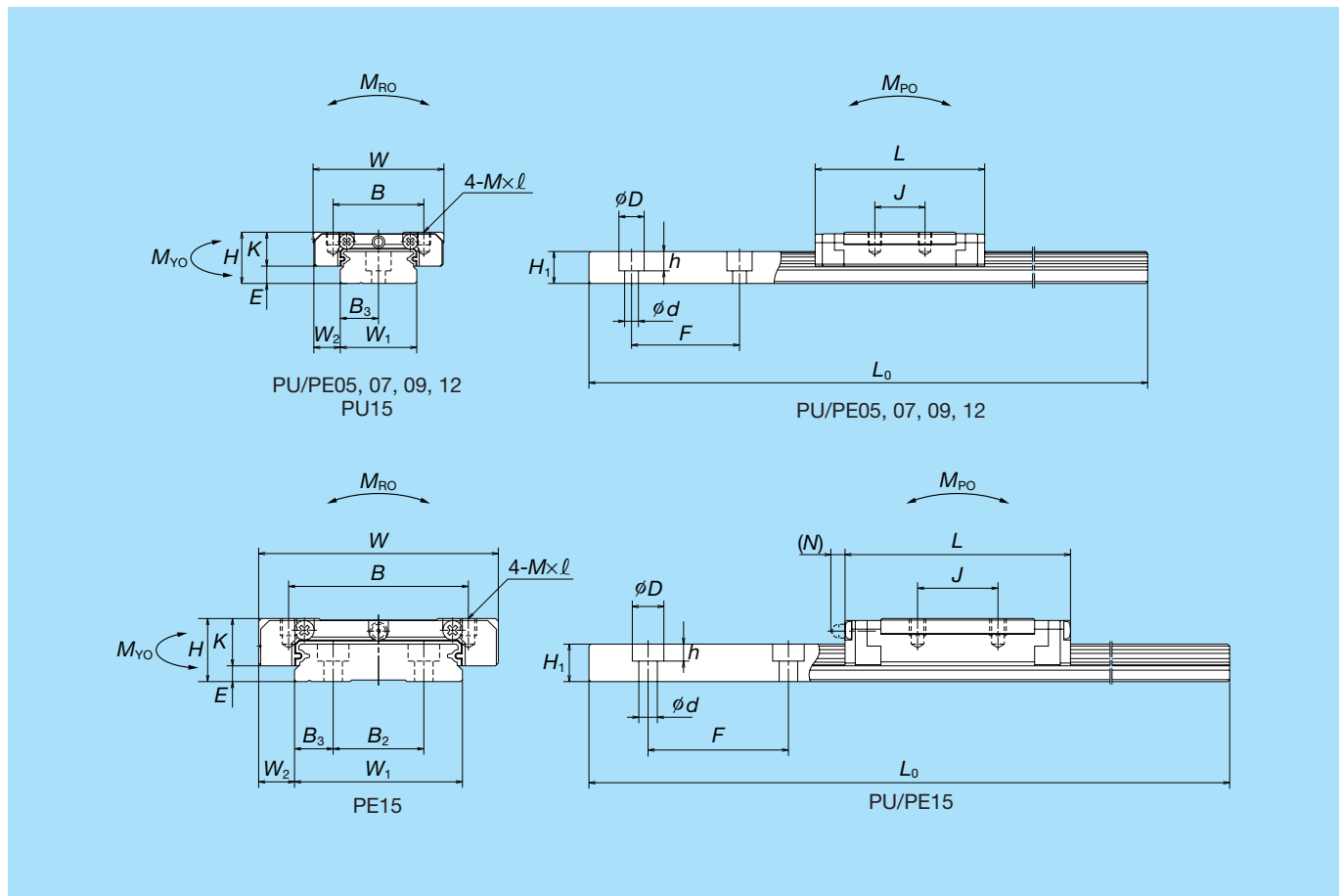

Unit: mm

Model No.	Assembly			Ball slide								Rail					Basic load rating					
	Height H	E	W ₂	Width W	Length L	Mounting tap hole			K	Grease fitting		Width W ₁	Height H ₁	Pitch F	Mounting bolt hole d×D×h	B ₃	Maximum length L _{0 max}	Dynamic C (N)	Static C ₀ (N)	Static moment (N·m)		
						B	J	M×Pitch×ℓ		Hole size	N									M _{RO}	M _{PO}	M _{YO}
PU05TR	6	1	3.5	12	19.4	8	—	M2×0.4×1.5	5	—	—	5	3.2	15	2.3×3.3×0.8	2.5	210	520	775	2	1	1
PU07AR	8	1.5	5	17	23.4	12	8	M2×0.4×2.4	6.5	—	—	7	4.7	15	2.4×4.2×2.3	3.5	375	1 090	1 370	5	3	3
PU09TR	10	2.2	5.5	20	30	15	10	M3×0.5×3	7.8	—	—	9	5.5	20	3.5×6×4.5	4.5	600	1 490	2 150	10	6	6
PU12TR	13	3	7.5	27	35	20	15	M3×0.5×3.5	10	—	—	12	7.5	25	3.5×6×4.5	6	800	2 830	3 500	21	11	11
PU15AL	16	4	8.5	32	43	25	20	M3×0.5×5	12	φ3	(3.3)	15	9.5	40	3.5×6×4.5	7.5	1 000	5 550	6 600	50	26	26

Unit: mm

Model No.	Assembly			Ball slide								Rail					Basic load rating						
	Height H	E	W ₂	Width W	Length L	Mounting tap hole			K	Grease fitting		Width W ₁	Height H ₁	Pitch F	Mounting bolt hole d×D×h	B ₂	B ₃	Maximum length L _{0 max}	Dynamic C (N)	Static C ₀ (N)	Static moment (N·m)		
						B	J	M×Pitch×ℓ		Hole size	N										M _{RO}	M _{PO}	M _{YO}
PE05AR	6.5	1.4	3.5	17	24.1	13	—	M2.5×0.45×1.5	5.1	—	—	10	4	20	3×5×1.6	—	5	150	690	1 160	6	3	3
PE07TR	9	2	5.5	25	31.1	19	10	M3×0.5×2.8	7	—	—	14	5.2	30	3.5×6×3.2	—	7	600	1 580	2 350	17	7	7
PE09TR	12	4	6	30	39.8	21	12	M3×0.5×3	8	—	—	18	7.5	30	3.5×6×4.5	—	9	800	3 000	4 500	37	17	17
PE12AR	14	4	8	40	45	28	15	M3×0.5×4	10	—	—	24	8.5	40	4.5×8×4.5	—	12	1 000	4 350	6 350	71	29	29
PE15AR	16	4	9	60	56.6	45	20	M4×0.7×4.5	12	φ3	(3.3)	42	9.5	40	4.5×8×4.5	23	9.5	1 200	7 600	10 400	207	59	59

Worldwide Sales Offices and Manufacturing Plants

NSK LTD.-HEADQUARTERS, TOKYO, JAPAN www.nsk.com

Nissei Bldg., 1-6-3, OHSAKI SHINAGAWA-KU, TOKYO 141-8560, JAPAN
ASIA BUSINESS STRATEGIC DIVISION-HEADQUARTERS
P: 03-3779-7145 F: 03-3779-7143 C: 81
INDUSTRIAL MACHINERY BEARINGS DIVISION-HEADQUARTERS
P: 03-3779-7227 F: 03-3779-7644 C: 81
AUTOMOTIVE DIVISION-HEADQUARTERS
P: 03-3779-7189 F: 03-3779-7917 C: 81
NEEDLE ROLLER BEARINGS STRATEGIC DIVISION-HEADQUARTERS
P: 03-5487-2563 F: 03-3779-7917 C: 81
PRECISION MACHINERY & PARTS DIVISION-HEADQUARTERS
P: 03-3779-7219 F: 03-3779-7644 C: 81

Africa

South Africa:

NSK SOUTH AFRICA (PTY) LTD.

JOHANNESBURG 25 Galaxy Avenue, Linbro Business Park, Sandton, Gauteng,
P: 011-571-1571, Welvin, 2059 Africa
P: 011-458-3600 F: 011-458-3608 C: 27

Asia and Oceania

Australia:

NSK AUSTRALIA PTY. LTD. www.nskaustralia.com.au

MELBOURNE 11 Dalmore Drive, Scoresby, Victoria 3173, Australia
P: 03 9764-8302 F: 03 9764-8304 C: 61
SYDNEY Unit 1, Riverside Centre, 24-28 River Road West, Parramatta, N.S.W. 2150, Australia
P: 02-9893-8322 F: 02-9893-8400 C: 61
BRISBANE 91 Wellington Road, East Brisbane Queensland 4169, Australia
P: 07-3393-1388 F: 07-3393-1236 C: 61
ADELAIDE 64 Greenhill Road, Wayville, South Australia 5034, Australia
P: 08-8373-4811 F: 08-8373-1053 C: 61
PERTH Unit 4, 36 Port Kambaja Drive, Bibra Lake, Western Australia 6163, Australia
P: 089-434-1311 F: 089-434-1318 C: 61

China:

NSK HONG KONG LTD.

HONG KONG Room 512, Wing On Plaza, Tsim Sha Tsui East, Kowloon, Hong Kong
P: 2739-9933 F: 2739-9323 C: 852

KUNSHAN NSK CO., LTD.

KUNSHAN 258 South Huang Pu Jiang Rd Kunshan E&T Development Zone Jiang Su 215335, China
P: 0512-5771-5654 F: 0512-5771-5689 C: 86

GUIZHOU HS NSK BEARINGS CO., LTD.

ANSHUN PLANT Dongjiao, Anshun, Guizhou 561000, China
P: 0853-3521505 F: 0853-3522722 C: 86

NSK STEERING SYSTEMS DONGGUAN CO., LTD.

DONGGUAN PLANT High-tech Park, Shilong Road, Guanlong Section, Dongguan, Guantong, 523119, China
P: 0769-242-7231 F: 0769-242-7827 C: 86

ZHANGJIAGANG NSK PRECISION MACHINERY CO., LTD.

JIANGSU PLANT Zhenxing Rd., Guotai North Rd., Zhangjiagang Economic Development Zone.,
Zhangjiagang City Jiangsu 215600, China
P: 0512-5867-6496 F: 0512-5818-0970 C: 86

TIMKEN-NSK BEARINGS (SUZHOU) CO., LTD.

JIANGSU PLANT Taishan Road 22 Suzhou New District, Jiangsu 215129, China
P: 0512-6685-5666 F: 0512-6665-9108 C: 86

NSK CHINA TECHNOLOGY CENTER

JIANGSU 258 South Huang Pu Jiang Road, Kunshan Economic & Technical Development Zone, Jiangsu 215335, China
P: 0512-5771-5654 F: 0512-5771-0748 C: 86

NSK (SHANGHAI) TRADING CO., LTD.

SHANGHAI 10th Fl. Building No. A, Shanghai Far East International Plaza, Bldg. A 319 Xian Xia Road, Shanghai 200051, China
P: 021-6235-0198 F: 021-6235-1033 C: 86

NSK REPRESENTATIVE OFFICES www.nsk.com.cn

BEIJING Room 1001, Beijing Fortune Bldg., 5 Dong San Huan Bei Lu, Chao Yang District, Beijing 100004, China
P: 010-6590-7231 F: 010-6590-2166 C: 86

SHANGHAI 10th Fl. Building No. A, Shanghai Far East International Plaza, 319 Xian Xia Road, Shanghai 200051, China
P: 021-6235-0198 F: 021-6235-1033 C: 86

GUANGZHOU Room 2701-02, Guangzhou International Electronics Tower 403,
Huan Qiu Rd. East, Guangzhou 510095, China
P: 020-8732-0583 F: 020-8732-0574 C: 86

ANSHUN Dongjiao, Anshun, Guizhou 561000, China
P: 0853-3522522 F: 0853-3522522 C: 86

CHENGDU Room 1901, Green Land 2, Zhongguo Zhongxing 2nd Street, Chengdu, 610016, China
P: 028-8661-4200 F: 028-8661-4343 C: 86

NSK (CHINA) INVESTMENT CO., LTD

SHANGHAI 10th Fl. Building No. A, Shanghai Far East International Plaza, 319 Xian Xia Road, Shanghai 200051, China
P: 021-6235-0198 F: 021-6235-1033 C: 86

India:

RANE NSK STEERING SYSTEMS LTD.

CHENNAI PLANT 14, Rajagopalai Salai, Vallancherry Guduvancherry, Pin-603 202, India
P: 04114-266002 F: 04114-266001 C: 91

NSK LTD. INDIA BRANCH OFFICE

CHENNAI 2A, First Street, Cenotaph Road, Chennai, 600 018, India
P: 044-2433-4732, 044-2434-3036, 3067 F: 044-2433-4733 C: 91

Indonesia:

PT. NSK BEARINGS MANUFACTURING INDONESIA

JAKARTA PLANT Blok M-4, Kawasan Berikat, MM2100, Industrial Town, Cikarang Barat,
Bekas, Jawa Barat, Indonesia
P: 021-898-0155 F: 021-898-0156, 021-898-0183 C: 62

PT. NSK INDONESIA

JAKARTA Summitas II 6th Fl., Jl. Jend. Sudirman Kav. 61-62, Jakarta 12190 Indonesia
P: 021-252-3458 F: 021-252-3223 C: 62

Korea:

NSK KOREA CO. LTD. www.kr.nsk.com

SEOUL 9F (West Wing) Posco Center 892, Deachi 4 Dong Kangnam-Ku, Seoul, Korea
P: 02-3287-0300 F: 02-3287-0345, 0445 C: 82

CHANGWON PLANT 60, Seongsan-Dong, Changwon, Kyungsangnam-Do, Korea
P: 055-287-6001 F: 055-285-9982 C: 82

Malaysia:

NSK BEARINGS (MALAYSIA) SDN. BHD.

KUALA LUMPUR 1001, Level 10, Uptown 2, 2 Jalan SS21/37, Damansara Uptown,
47400 Petaling Jaya, Selangor Darul Ehsan, Malaysia
P: 03-7722-3373 F: 03-7728-5543, 7728-7450 C: 60

PRAI 10, Lengkok Makcik 1, Taman Inderawasih, 13600 Prai, Penang, Malaysia
P: 04-3991763 F: 04-3991830 C: 60

JOHOR BAHRU Ground Floor, No. 27, Jalan Bakawali 50, Taman Johor Jaya,
81100 Johor Bahru, Johor, Malaysia
P: 07-3546290 F: 07-3546291 C: 60

KOTA KINABALU Lot 10, Lrg. Kurma 4, Likas Ind. Centre, 5/1 Miles, Jalan Tuaran,
88450 Inanam Sabah, Malaysia
P: 088-421260 F: 088-421261 C: 60

NSK MICRO PRECISION (M) SDN. BHD.

MALAYSIA PLANT No.43 Jalan Taming Dua, Taman Taming Jaya, 43300 Balakong, Selangor Darul Ehsan, Malaysia
P: 03-8961-6288 F: 03-8961-6488 C: 60

New Zealand:

NSK NEW ZEALAND LTD. www.nsk-rhp.co.nz

AUCKLAND 3 Te Apunga Place Mt. Wellington, Auckland, New Zealand
P: 09-276-4992 F: 09-276-4082 C: 64

Philippines:

NSK REPRESENTATIVE OFFICE

MANILA Unit 910 Philippine AXA Life Centre, 1286 Seno Gil Puyat Avenue,
Makati City 1200, Metro Manila, Philippines
P: 02-759-6246 F: 02-759-6249 C: 63

Singapore:

NSK INTERNATIONAL (SINGAPORE) PTE LTD.

SINGAPORE 2 Toh Guan Road East #02-02 Singapore 608837
P: 6273-0357 F: 6275-8937 C: 65

NSK SINGAPORE (PTE) LTD.

SINGAPORE 2 Toh Guan Road East #02-03 Singapore 608837
P: 6278-1711 F: 6273-0253 T: RS24058 C: 65

Taiwan:

TAIWAN NSK PRECISION CO., LTD.

TAIPEI 9th Fl., 34, Chung Shan N. Rd., Sec. 3, Taipei, Taiwan R.O.C.
P: 02-2591-0386 F: 02-2597-7151 C: 86

TAICHUNG 107-6, SEC. 3, Wenxin Rd., Taichung, Taiwan R.O.C.
P: 04-2311-7978 F: 04-2311-2627 C: 86

TAINAN No.48, Lane 62, Fusing Rd., Sinshin Township, Tainan County 744, Taiwan, R.O.C.
P: 06-589-2703 F: 06-589-2719 C: 86

Thailand:

NSK BEARINGS (THAILAND) CO., LTD.

BANGKOK 25th Fl. RS Tower, 12176-77 Rachadaphisek Road, Dindaeng, Bangkok 10320, Thailand
P: 02-6412-150-58 F: 02-6412-161 C: 66

NSK BEARINGS MANUFACTURING (THAILAND) CO., LTD.

CHONBURI PLANT 700/430 Moo 7, Amata Nakorn Industrial Estate T. Donhualor,
A. Muangchomburi, Chonburi 20000 Thailand
P: 038-454010-454016 F: 038-454017, 454020 C: 66

SIAM NSK STEERING SYSTEMS CO., LTD.

CHACHOENGSAO PLANT 90 Moo 9, Wellgong Industrial Estate, Km. 36 Bangna-Trad Road, Bangwao,
Bangpakong, Chachoengsao 24180, Thailand
P: 0342-350 F: 038-522-351 C: 66

NSK ASIA PACIFIC TECHNOLOGY CENTRE (THAILAND) CO., LTD.

CHONBURI 700/430 Moo 7, Amata Nakorn Industrial Estate T. Donhualor,
A. Muangchomburi, Chonburi 20000 Thailand
P: 038-454631-454633 F: 038-454633, 454634 C: 66

Europe

NSK EUROPE LTD. (EUROPEAN HEADQUARTERS) www.eu.nsk.com

MAIDENHEAD, UK Belmont Place, Belmont Road, Maidenhead, Berkshire SL6 6TB U.K.
P: 01628-509800 F: 01628-509808 C: 44

France:

NSK FRANCE SAS

PARIS Quartier de l'Europe, 2 Rue Georges Guynemer, 78283 Guyancourt Cedex, France
P: 01-30-57-39-39 F: 01-30-57-00-01 C: 33

Germany:

NSK DEUTSCHLAND GMBH

DÜSSELDORF Harkortstrasse 15, 40880 Ratingen, Germany
P: 02102-4811-0 F: 02102-4811-2290 C: 49
STUTTGART Sielminger Str. 65, 70771 Leinfelden-Echterdingen, Germany
P: 0711-79082-0 F: 0711-79082-289 C: 49
LEIPZIG Zschortauer Str. 76, 04129 Leipzig, Germany
P: 0341-5631241 F: 0341-5631243 C: 49

NSK PRECISION EUROPE GMBH

DÜSSELDORF Harkortstrasse 15, 40880 Ratingen, Germany
P: 02102-4811-0 F: 02102-4811-2290 C: 49

NSK STEERING SYSTEMS EUROPE LTD.

STUTTGART Sielminger Strasse 65 D-70771 Leinfelden-Echterdingen, Germany
P: 0771-79082-277 F: 0771-79082-289 C: 49

NEUWEG FERTIGUNG GMBH

CORPORATE Ehinger Strasse 5, D-89597 Munderkingen, Germany
OFFICE/PLANT P: 07393-540 F: 07393-5414 C: 49

Italy:

NSK ITALIA S.p.A.

MILANO Via Garibaldi, 215, I-20024 Garbagnate Milanese (MI), Italy
P: 02-95-51911 F: 02-990-25-778, 02-990-28-373 C: 39

INDUSTRIA CUSINETTI S.p.A.

TORINO PLANT Via Giotto 4, 10080, S. Benigno C. se, Torino, Italy
P: 0119824811 F: 0119880284 C: 39

Netherlands:

NSK EUROPEAN DISTRIBUTION CENTRE B.V.

De Kroonstraat 38, 5048 AP Tilburg, Nederland
P: 013-4647647 F: 013-4647648 C: 31

Poland:

NSK EUROPE LTD. WARSAW LIAISON OFFICE

WARSAW LIAISON Przedstawicielstwo w Warszawie, ul. Miodowa 4 lok. 73, 02-796 Warsaw, Poland
OFFICE P: 022-645-1525, 1526 F: 022-645-1529 C: 48

NSK ISKRA S.A.

CORPORATE Ul. Jagiellonska 109, 25-734 Kielce, Poland
OFFICE/PLANT P: 041-366-5001 F: 041-366-5008 C: 48

NSK EUROPEAN TECHNOLOGY CENTER, POLAND OFFICE

UL. Jagiellonska 109, 25-734 Kielce, Poland
P: 041-366-5812 F: 041-366-5206 C: 48

Spain:

NSK SPAIN S.A.

BARCELONA Calle de la Hidráulica, 5, P.I. "La Ferreria" 08110 Montcada i Reixac (Barcelona), Spain
P: 093-575-4041 F: 093-575-5200 C: 34

Turkey:

NSK BEARINGS MIDDLE EAST TRADING CO., LTD.

ISTANBUL Fevzi Cakmak Caddesi, No.11/4, Maltepe 34844, Istanbul, Turkey
P: 0216-442-7106 F: 0216-305-5505 C: 90

United Kingdom:

NSK BEARINGS EUROPE LTD.

PETERLEE 3 Brindley Road, South West Industrial Estate, Peterlee, Co. Durham, SR8 2JD U.K.
P: 0191-586-6111 F: 0191-586-3482 C: 44

PLANT PETERLEE (FORGE) Davy Drive, North West Industrial Estate, Peterlee, Co. Durham, SR8 2PW U.K.
P: 0191-518-0777 F: 0191-518-0303 C: 44

NEWARK Northern Road, Newark, Nottinghamshire, NG24 2JF U.K.
PLANT P: 01636-605123 F: 01636-643072 C: 44

NSK EUROPEAN TECHNOLOGY CENTRE

NEWARK, UK Northern Road, Newark, Notts, NG24 2JF U.K.
P: 01636-605123 F: 01636-643241 C: 44

NSK UK LTD.

NEWARK Northern Road, Newark, Nottinghamshire, NG24 2JF U.K.
P: 01636-605123 F: 01636-643050 C: 44

NSK STEERING SYSTEMS EUROPE LTD.

CORPORATE Silverstone Drive, Rowley's Green, Coventry, Warwickshire CV6 6PA U.K.
OFFICE P: 02476-588588 F: 02476-585999 C: 44

PETERLEE 67 Doford Drive, South West Industrial Estate, Peterlee, Co. Durham, SR8 2RL U.K.
PLANT P: 0191-518-6400 F: 0191-518-6440 C: 44

North and South America

NSK AMERICAS, INC. (AMERICAN HEADQUARTERS)

ANN ARBOR 4200 Goss Road, Ann Arbor, Michigan 48105-2703, U.S.A.
P: 734-913-7500 F: 734-913-7511 C: 1

Argentina:

NSK ARGENTINA SRL

BUENOS AIRES Garcia del Rio 2477 PISO 7º OF. "A" C1429DEA-Buenos Aires-Argentina
P: 11-4704-5100 F: 11-4704-0033 C: 54

Brazil:

NSK BRASIL LTDA. www.br.nsk.com

SÃO PAULO Rua Treze de Maio, 1633-14° Andar-Bela Vista São Paulo-SP, Brazil 01327-905
P: 011-3269-4723 F: 011-3269-4720 C: 55

SUZANO PLANT Av. Versador João Batista Fritipaldi, 66-Vila Maluf Suzano-SP, Brazil 08685-000
P: 011-4741-4090 F: 011-4748-2355 C: 55

BELO HORIZONTE Rua Ceará, 1431-4° andar-sala 405-Funçionários Belo Horizonte-MG, Brazil 30150-311
P: 031-3274-2477 F: 031-3273-4408 C: 55

JOINVILLE Rua Blumenau, 178-sala 910-Centro Joinville-SC, Brazil 89204-250
P: 047-422-5511 F: 047-422-2817 C: 55

PORTO ALEGRE Av. Cristóvão Colombo, 1694-sala 202-Floresta Porto Alegre-RS, Brazil 90560 001
P: 051-3222-1324/3346-7851 F: 051-3222-2599 C: 55

RECIFE Av. Conselheiro Aguiar, 2738-6° andar-oonj. 604-Boa Viagem Recife-PE, Brazil 51020-020
P: 081-3326-3781 F: 081-3326-5047 C: 55

Canada:

NSK CANADA INC. www.ca.nsk.com

HEAD OFFICE 5585 McAdam Road, Mississauga, Ontario, Canada L4Z 1N4
P: 905-890-0740 F: 905-890-0488 C: 1

MONTREAL 2150-32E Avenue, Lachine, Quebec, Canada H8T 3H7
P: 514-633-1220 F: 514-633-8164 C: 1

TORONTO 5585 McAdam Road, Mississauga, Ontario, Canada L4Z 1N4
P: 905-890-0561 F: 905-890-1935 C: 1

VANCOUVER 3353 Wayburne Drive, Burnaby, British Columbia, Canada V5G 4L4
P: 604-294-1151 F: 604-294-1407 C: 1

Mexico:

NSK RODAMIENTOS MEXICANA, S.A. DE C.V. www.mx.nsk.com

MEXICO CITY Minas Palacio No.42-6, Col. San Antonio Zomeyucan, Naulcapan de Juarez, C.P. 53750, Estado de Mexico, Mexico
P: 55-5301-2741, 55-5301-3115, 55-5301-4762 F: 55-5301-2244, 55-5301-2865 C: 52

United States of America:

NSK CORPORATION www.nsk-corp.com

[CORPORATE OFFICE]
ANN ARBOR 4200 Goss Road, Ann Arbor, Michigan 48105-2703, U.S.A.
P: 734-913-7500 F: 734-913-7511 C: 1

[NSK AMERICAN TECHNOLOGY CENTER]
ANN ARBOR 4200 Goss Road, Ann Arbor, Michigan 48105-2703, U.S.A.
P: 734-913-7500 F: 734-913-7852 C: 1

[BRANCHES and

Motion & Control

No. 18 August 2005

Published by NSK Ltd.



Printed on 100% recycled paper.