

*NSK Technical Journal*

# Motion & Control

**No.16 August 2004**

**Special Issue of  
Machine Tool Products**



ISSN1342-3630

**NSK**

*MOTION & CONTROL No.16*

*NSK Technical Journal*

*Printed and Published: August 2004*

*ISSN1342-3630*

*Publisher: NSK Ltd., Ohsaki, Shinagawa, Tokyo, JAPAN*

*Public Relations Department*

*TEL +81-3-3779-7051*

*FAX +81-3-3779-7431*

*Editor: Hisashi MACHIDA*

*Managing Editor: Masami EISHIMA*

*Design, Typesetting & Printing: Fuji Ad. Systems Corp.*

© NSK Ltd.

*The contents of this journal are the copyright of NSK Ltd.*

*Cover photos:*

*High-Speed Precision Angular Contact Ball Bearings—Spinshot™II*

*Super Precision Sealed Angular Contact Ball Bearing*

*Sealed Angular Contact Thrust Ball Bearing for Ball Screw Support*

*High-Performance Cylindrical Roller Bearings*

*NSK RA Series Roller Guide*

*High-Speed and Low-Noise Ball Screw*

# Motion & Control

## No. 16

August 2004

## Contents

### Special Articles

Preface	Tadao Inomata	1
Latest Trends in Machine Tool Spindles and Bearing Technology	Shinji Nishibata	2
Development of Integrated Motor Spindle Unit for Machine Tools Using Automatic Grease Replenishing System	Mitsuho Aoki, Yasushi Morita	11
Development of High-Speed and Low-Noise Ball Screws	Masato Kato	22
Numerical Analysis Technology & NSK Linear Guides™ for Machine Tools	Jun Matsumoto	29

### New Products

High-Speed Precision Angular Contact Ball Bearings—Spinshot™ II	38
Super Precision Sealed Angular Contact Ball Bearings	40
Sealed Angular Contact Thrust Ball Bearings for Ball Screw Supports	42
High-Performance Cylindrical Roller Bearings	44
NSK RA Series Roller Guide	48

### Technical Paper

EPS Control Technology	Shuji Endo, Hideyuki Kobayashi	51
New Products		
Step-and-Repeat Proximity Aligner for Production of Large-Sized LCD Glass Substrates		57

# NSK's Machine Tool Products

*Tadao Inomata*  
Advisor

Machine tool technology has progressed for the past several decades due in part to superior numerical control (NC) technology. At the same time, highly important components of machine tools, such as spindles, precision bearings, ball screws, and linear guides are playing a significant role in helping advancement of machine tools in both quality and quantity. NSK, an exclusive company in the world that manufactures such machine elements, has always been committed to research and development in support of the progress of machine tool technology.

In this most recent special issue of NSK Technical Journal, we have focused on machine tool products and have introduced the results of cutting-edge research and development and products that cover several fields. In addition to meeting or exceeding customer expectations of high-speed and high accuracy for the latest machine tools, new needs and expectations have arisen in regards to environmental concerns and energy conservation. NSK's new technologies and new products introduced in this journal respond to those very needs, which continue to be highly valued by our customers. We faced many challenges but were successful by drawing upon the collective strength of NSK's research and development expertise.

High-speed requirements are met with NSK's ultra high-speed machine tool spindle, which continues to attract attention throughout the industry. The ultra high-speed machine tool spindle technology introduced in this journal made its public debut at the 21st Japan International Machine Tool Fair (JIMTOF 2002). The spindle and our Spinshot II bearings, which are used in the spindle, are highly acclaimed by many of our customers.

We also developed a new numerical analysis technology for linear guides that includes a feeding system with greater accuracy, which we have succeeded at putting into practical use. Utilizing this same technology, we developed highly rigid roller guides, which are also introduced in this journal.

For environmental measures, we developed high-speed, low-noise ball screws, which have attracted considerable interest for making the machine tool operators working environment much quieter. NSK also introduced a motorized machine tool spindle that uses replenishable grease lubrication. This new product, although competing in the domain of high-speed products where oil-air lubrication is traditionally used, uses grease lubrication, which reduces the amount of required air. Thus, this grease replenishment lubrication system results in less energy consumption; a factor that is highly appreciated and provides for overall quieter operations.

As mentioned earlier, NSK is proceeding with product development that responds to user needs in all aspects of machine tools and related components. This reflects our commitment to ensure that our customers will continue being satisfied using NSK products for years to come. In 2002, China became the leading buyer of machine tools; an indication of a big change in the machine tool market. When market changes occur, new needs arise. NSK will continue to support progress in the machine tool industry through research and development that meet such new and changing market needs. Through ongoing developments, we will continue to incorporate the latest technologies into our products to meet the needs of our customers.



*Tadao Inomata*

# Latest Trends in Machine Tool Spindles and Bearing Technology

Shinji Nishibata  
Bearing Technology Center

## ABSTRACT

In recent years, function-related requirements of machine tool main spindles have included higher operating speeds, greater rigidity, and more accuracy. While meeting such requirements, machine tools are also required to be ecologically sensitive to global warming and must promote preservation of the environment. Machine tools on exhibit at the 21st Japan International Machine Tool Fair (JIMTOF 2002) confirmed this growing trend. In order to meet the demand for products that respond to such a wide spectrum of requirements of high functionality and environmental friendliness, NSK has developed the ROBUST series of precision bearings and the High Rigidity series of double row cylindrical roller bearings for machine tools. Both of these series for machine tool applications are supported by significant improvements in computer analysis technology, new materials, ceramic roller elements, engineered plastic cages, and a newly developed lubrication system.

## 1. Introduction

In recent years, machine tool makers have developed increasingly sophisticated products in order to enhance the efficiency of machine tools. For example, they are developing machining centers that can process at higher speeds and greater accuracy, and lathes that are able to process with greater rigidity and higher accuracy.

Furthermore, recent trends in response to global warming and environmental preservation have resulted in more focus on reduced energy consumption through greater ecological awareness, and improved working conditions through reduced environmental contamination and less operating noise. It was under these conditions that the 21st JIMTOF was held in November 2002.

This report introduces the latest trends of machine tools exhibited in JIMTOF 2002, and NSK's precision bearing products, including the ROBUST series, and technologies that work to support these products.

## 2. Machine Tool Spindle Trends at JIMTOF 2002

In JIMTOF 2002, many ecologically sensitive machine tools were exhibited in addition to the latest machine tools with ultra-high-speed and ultra-high-accuracy capabilities, including multi-task machines, were developed using the latest in information technology. In this article, we will compare the trends of high-speed machine tool spindles based on exhibits of past machine tool fairs.

### 2.1 Transition of exhibited high-speed spindles

Fig. 1 shows a summary of 20 years of JIMTOF exhibits of high-speed machine tools with operating speeds higher than 10 000 rpm. Although a recession in the machine tool industry resulted in some machine tool makers canceling their exhibitions in JIMTOF 2002, the total number of high-speed machine tools was 300 units, which was similar

to the number of units exhibited in JIMTOF 2000. Since the introduction of machine tool spindles with operating speeds of 10 000 rpm in JIMTOF 1982, the number of high-speed machine tools on display has subsequently increased with each trade show. Key technologies that contributed to making high-speed operations a reality are oil-air lubrication systems, ceramic ball bearings, and low temperature-rise ROBUST bearings.

Compared to previous trade shows, the overall number of high-speed machine tools remained static, which would seem to indicate that there has been little progress made in the high-speed machine tool spindle industry. Conversely, significant progress has been made, but only focused on other factors besides speed. Machine tool makers developed new models that focused more on higher accuracy, multi-spindle designs, five-face machining, greater integration and standardization of machine tools, and development of machines that are more ecologically sound while offering greater cost performance.

### 2.2 Lubrication methods and high-speed spindles

Fig. 2 shows the rotational speeds of machine tool spindles for specific lubrication method and preloading method. For example, we can see that machine tool spindles with a 65 mm shaft operating under grease lubrication with position preload can operate at  $1.7 \times 10^6 d_m n$  (Product of pitch circle diameter of rolling elements:  $d_m$ , (mm), and speed  $n$ , (rpm)). This particular machine uses an automated grease replenishment system, whereas most ultra high-speed machine tool spindles operating between  $2.5$  and  $3.0 \times 10^6 d_m n$  use oil lubrication and constant pressure preload.

Fig. 3 shows the transition of high-speed operation under grease lubrication as exhibited at the last three trade shows. Initially, oil was the primary lubrication for machine tools exceeding a limiting speed of  $1.3 \times 10^6 d_m n$ .

Since JIMTOF 2002, however, main spindles with grease lubrication were exhibited in this range. We can reason from this that makers are responding to environmental concerns.

### 2.3 NSK exhibition at JIMTOF 2002

In order to help educate prospective customers regarding NSK's highly valued products, we exhibited an ultra high-speed spindle ( $4.0 \times 10^6 d_m n$ ) that had the highest speed for rolling bearings. Product details include a shaft diameter of 65 mm, operating speed of 45 000 rpm under constant pressure preload. We also exhibited a high-speed ( $1.8 \times 10^6 d_m n$ ) machine tool spindle using grease lubrication with a shaft diameter of 70 mm, and an operating speed of 20 000 rpm under position preload.

The ultra high-speed spindle with a limiting speed of  $4.0 \times 10^6 d_m n$  achieves ultra-high speeds, low noise, and high accuracy by adopting a new super lean lubrication method, high-precision ROBUST bearings, and technology for multi-axis balance level accuracy. Furthermore, the high-speed grease lubrication spindle ( $1.8 \times 10^6 d_m n$ ) ensures longer life by adopting a grease replenishment method and is maintenance free for 10 000 hours.

As described above, expanded functionality of machine tools is a constant requirement. Examples include ultra-high speeds and low vibration for die processing, or ultra high-speed and heavy cutting capability of hard-to-machine materials and aluminum for aircraft components. Demand is also growing for higher speeds for machine tools operating under grease lubrication in

response to environmental concerns. In order to realize higher speeds, advancements in bearing technology and peripheral technologies are being made. Fig. 4 illustrates progress made in such high-speed technologies. The horizontal axis shows time and the vertical axis shows the limiting speed ( $d_m n$  value) of high-speed spindle bearings developed and put into practical use at a given time. Recently, NSK has developed the ROBUST series of angular contact ball bearings and cylindrical roller bearings, Spinshot™ bearings, an automated lubrication system, and an ultra high-speed spindle with super lean lubrication. Further details of the products are discussed throughout other articles in this issue of Motion & Control. The technologies that contributed forward these developments are discussed in this article.

### 3. High-Speed Technology

Forty percent of high-speed machine tools (10 000 rpm or higher) exhibited at JIMTOF 2002 adopted NSK's ROBUST series bearings. In the world of motion control, the name of this series reflects on how tough these bearings are. With the development of integral motorized spindles, higher speeds with greater efficiency were achieved. However, integral motorized spindles must contend with heat build-up that requires an external cooling system. The internal build up of heat at high temperatures and exposure to external cooling create a severe operating environment for the bearings. During

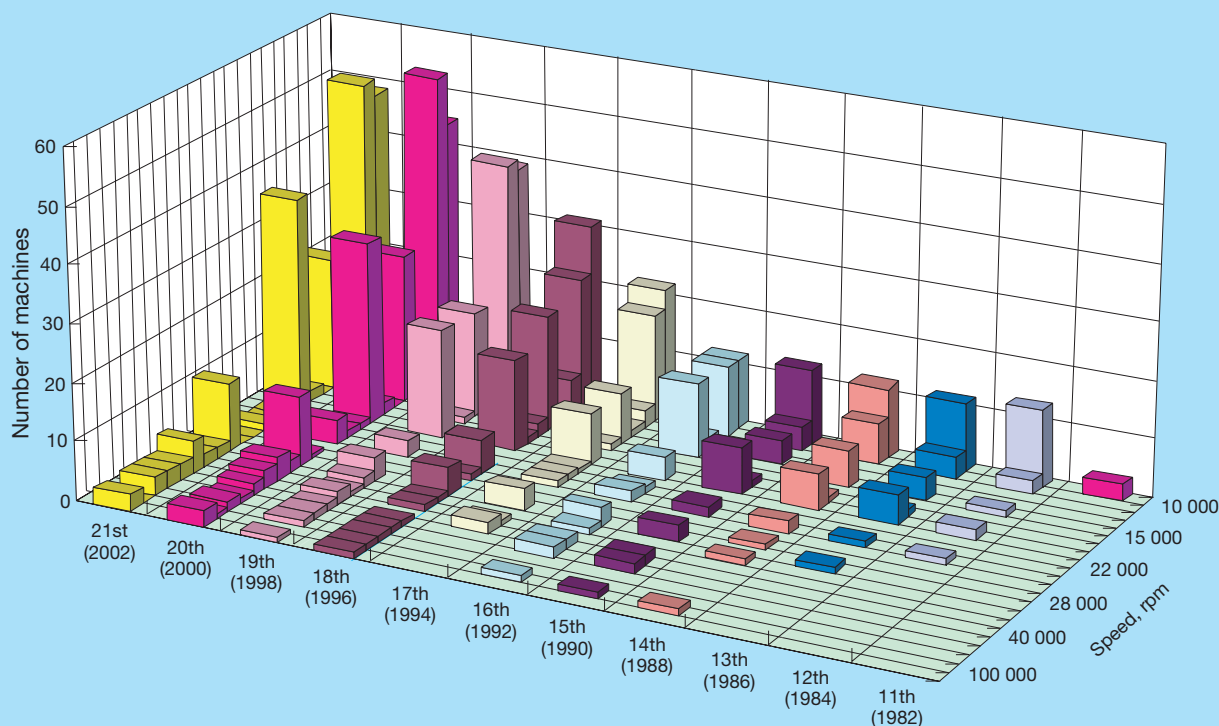

Fig. 1 Number of machines exhibited at JIMTOF with operating speeds higher than 10 000 rpm

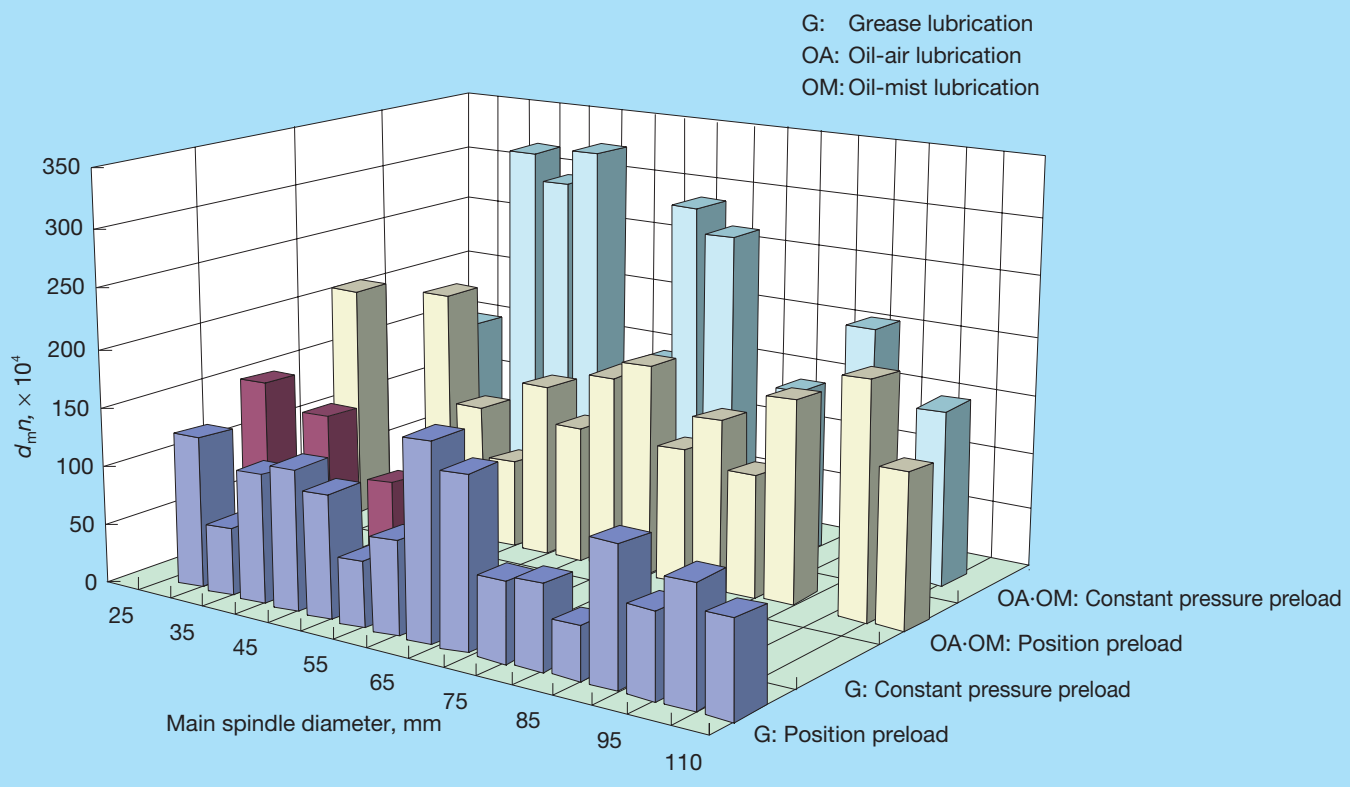

Fig. 2 Rotational speed of machine tool spindles for specific lubrication systems and preloading methods

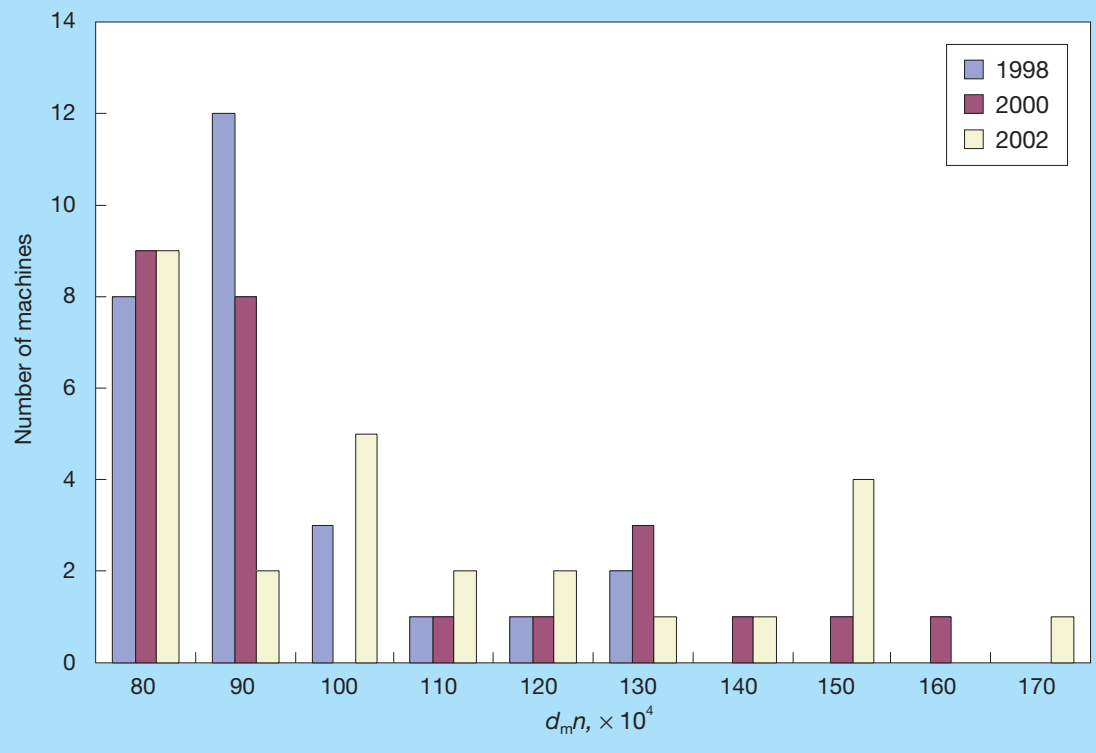

Fig. 3 Rotational speed of machine tool spindles under grease lubrication and position preload

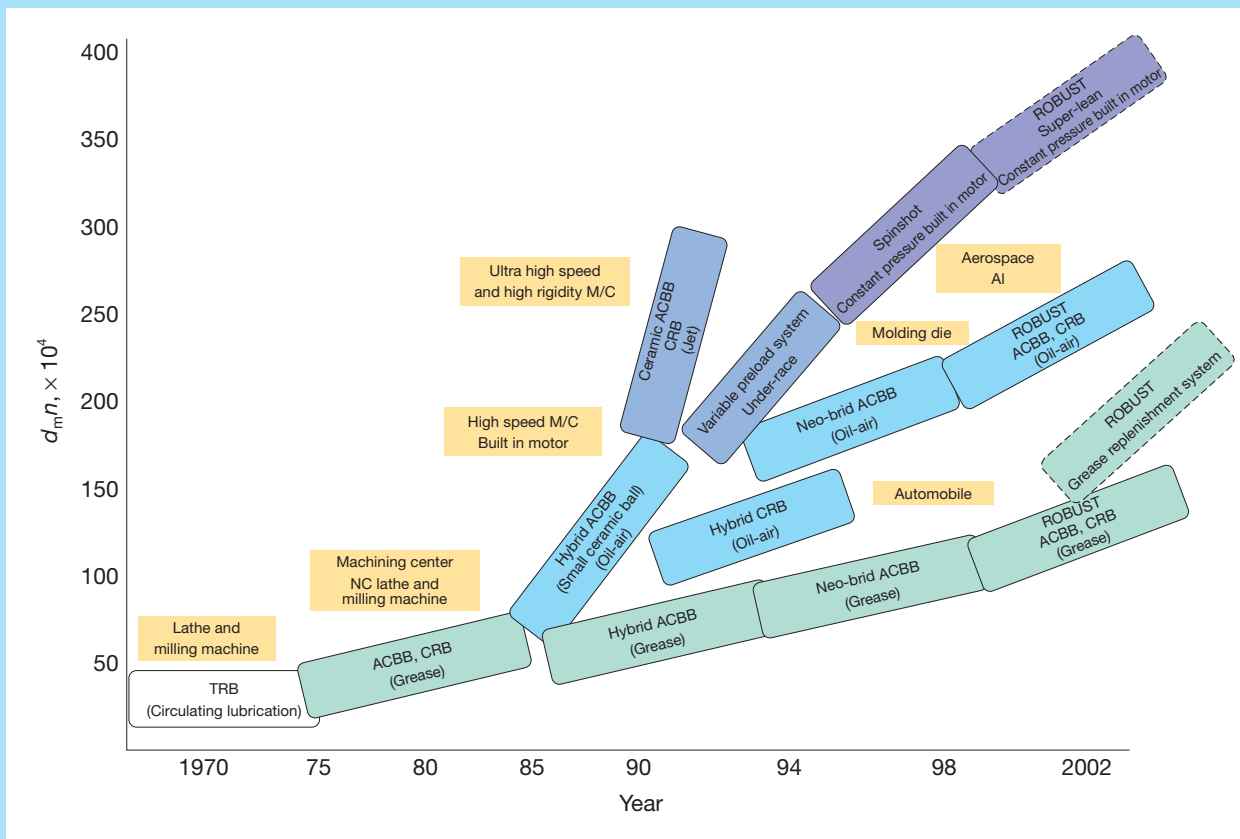

Fig. 4 Rotational speed of machine tool spindles

this transition period of drastic rotating speed changes throughout the industry, it became necessary to increase bearing reliability against increasingly harsh external factors. To meet customer needs, NSK has developed the ROBUS series, which are widely accepted in the field now.

### 3.1 Development of the ROBUS series

Modern high-speed machine tool spindles often incorporate integral motorized spindles. Consequently, operating temperatures vary widely and cause changes in internal bearing load. The ROBUS series bearings minimize the adverse effects that temperature variation has on internal bearing load. NSK utilized the latest in computer analysis technology and material technology to develop the robustness of these bearings, while computer analysis technology was focused on minimizing heat generation of the bearing. An example of analysis and the results of rotating tests are shown in Fig. 5. NSK's ROBUS series angular contact ball bearings were developed as a result of this analysis. Bearing performance includes minimal fluctuations in temperature rise and PV values for differences in temperatures of the inner and outer rings of the bearing (See Fig. 6).

By adopting ROBUS bearings, machine tool spindles can increase rotational speed by 20% while maintaining

conventional bearing performance such as high rigidity and long grease life.

Furthermore, our ROBUS products use high-speed heat-resistant steel (SHX material), achieve position preload at  $2.0 \times 10^6 d_m n$ , and by the optimization of oil-air lubrication (Spinshot™ II),  $2.5 \times 10^6 d_m n$  was realized with position preload (See Fig. 7).

Computer analysis is used to estimate temperature variation for different designs of spindles in order to determine an optimum bearing specification. Since the pattern of contact area is different between ball bearings and cylindrical roller bearings, ROBUS series cylindrical roller bearings were developed differently. Generally, ball bearings are suitable for high-speed operations, where roller bearings are difficult to use due to the sliding surface of the rib face, which controls roller orientation. However, by analyzing the sliding surface between the roller and the rib face, we reduced the PV value and restricted the amount of wear. Thus we were able to achieve a limiting speed of  $3.0 \times 10^6 d_m n$  (Fig. 8).

### 3.2 Development of steel material

For longer bearing life and improved rolling fatigue life resulting from metal fatigue, it is necessary to improve bearing steel cleanliness. NSK has since developed high

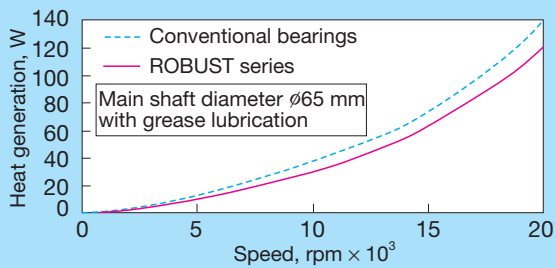

(a) Calculated values

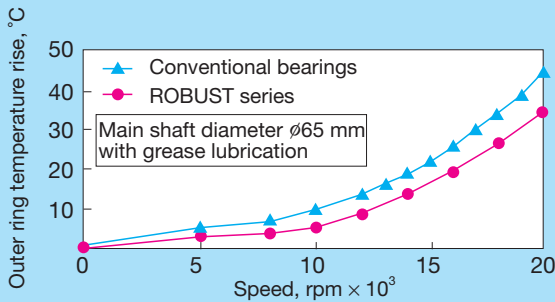

(b) Measured values

Fig. 5 Analysis and test results of  $\phi 65$  (I.D.) bearings

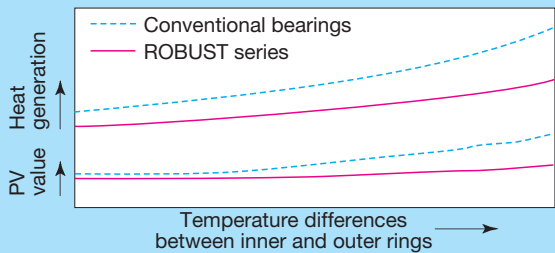

Fig. 6 Analysis results for temperature robustness

cleanliness steels such as Z steel and EP steel by establishing evaluation technology of non-metallic inclusions and steel making technology. Life test results for these materials are illustrated in Fig. 9. Test results show that bearings made with Z steel, which is the standard material of NSK precision bearings, have 1.8 times longer life than those made of vacuum-degassed steel. NSK also recommends high-speed heat-resistant SHX steel (developed by NSK) for applications exceeding  $1.5 \times 10^6 d_m n$ . SHX steel has excellent properties such as

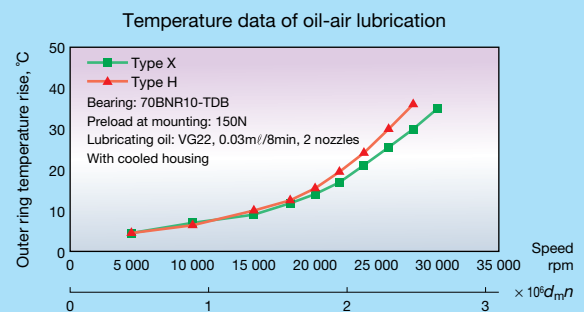
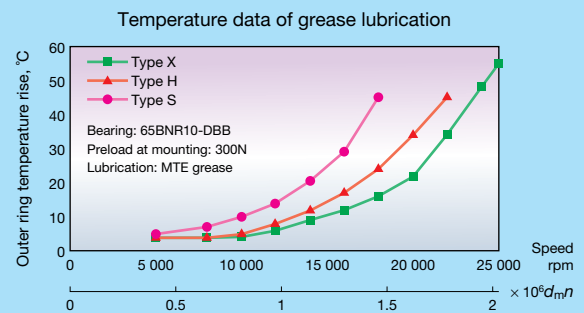

Fig. 7 Test results

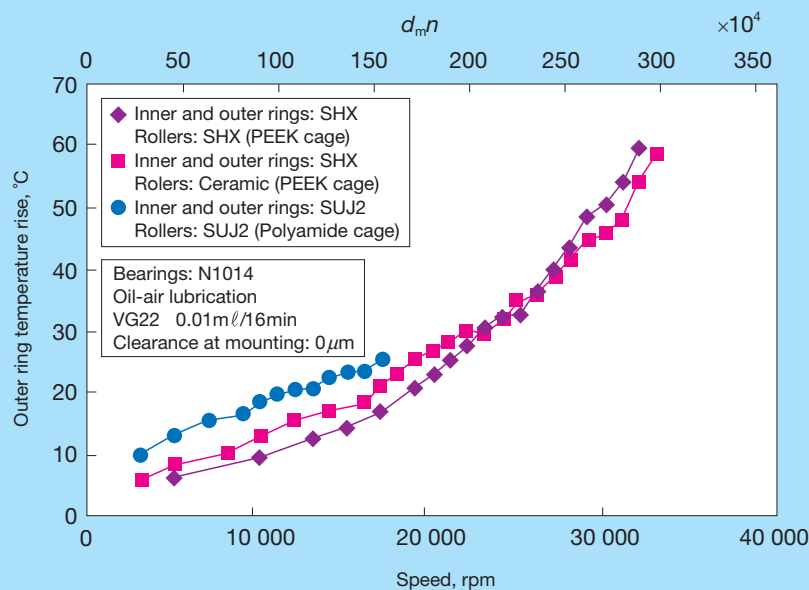

Fig. 8 High-speed cylindrical roller bearing test results

superior seizure resistance, enhanced wear resistance, and longer life, even under insufficient lubricating oil conditions (Fig. 10). Fig. 11 shows the result of a flaking test. Compared to vacuum-degassed bearing steel, SHX steel shows four times longer life under clean lubrication conditions. As a result of testing with ceramic balls, SHX steel showed 30% better dent resistance than bearing steel.

### 3.3 Ceramic rolling elements

For angular contact ball bearings, ceramic balls make a significant contribution towards the high-speed capabilities of spindles. Ceramic balls for machine tools are made of silicon nitride ( $\text{Si}_3\text{N}_4$ ), which are 40% lighter than steel balls. The lighter weight means that centrifugal

force acting on rolling elements, and sliding, which is due to gyro moment, are both significantly reduced. Whereas the coefficient of linear expansion is small, lower induced preload reduces internal heat generation effectively during high-speed operation (Fig. 12).

Furthermore, high Young's modulus of ceramic products results in smaller elastic deformation, which reduces sliding.

For cylindrical roller bearings, ceramic rollers offer the same advantages in part to being lightweight and their coefficient of linear expansion. Although comparison test results with SHX rollers revealed no difference at  $2 \times 10^6 d_m n$ , superiority of ceramic rollers is realized at limiting speeds higher than  $2 \times 10^6 d_m n$  (Fig. 8).

### 3.4 Development of cage material

Cage performance has a remarkable impact on the improvement of high-speed operations of bearings in machine tool applications. The polymer cages are popular for machine tool bearing for their lightweight, self-lubricating, and low-friction characteristics.

For angular contact ball bearings operating at a limiting speed of  $1.4 \times 10^6 d_m n$ , performance is improved by adopting a ball-guided polyamide resin cage that was developed to lessen vibration and noise. Whereas the cage is guided by balls, as opposed to the outer ring, internal

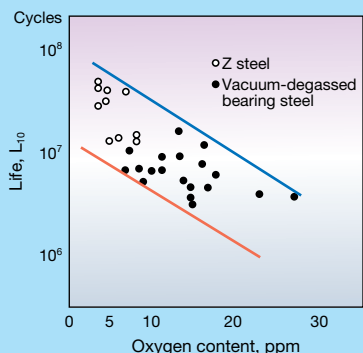

Fig. 9 Fatigue life

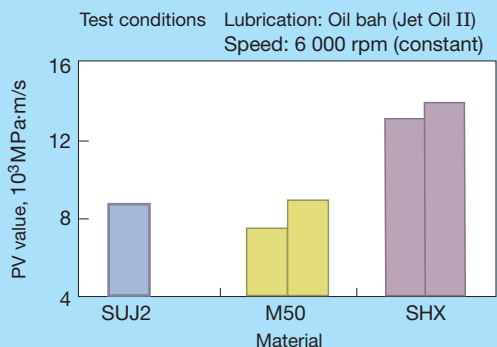
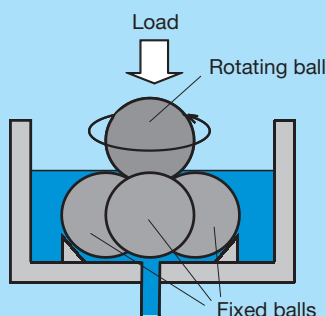

Fig. 10 Seizure limit test (Four-ball test)

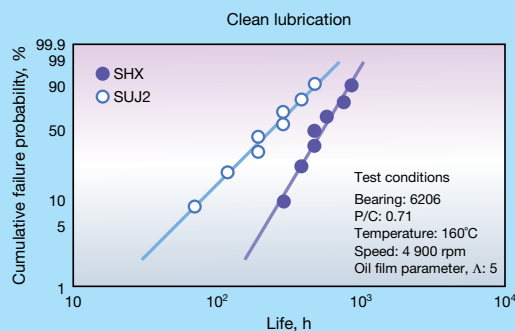

Fig. 11 Life test for subsurface-originated flaking test

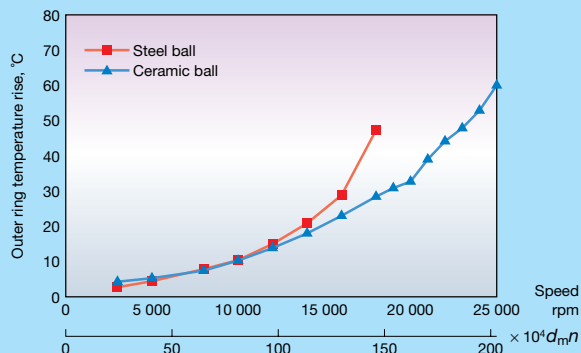

Fig. 12 Comparison of ceramic and steel balls

heat generation is effectively reduced, and internal free space of the bearing is increased for holding more lubricant on the outer ring side for enhanced grease life. A conventional machined cage would be too cost prohibitive, but with polyamide resin, low manufacturing costs are achieved by injection molding.

Fig. 13 shows differences in performance between conventional phenolic resin cages and polyamide resin cages. Limiting speed of conventional polyamide resin cages is  $1.15 \times 10^6 d_m n$ . Our newly developed polyamide resin cage, however, has a limiting speed of  $1.4 \times 10^6 d_m n$ . For limiting speeds exceeding  $1.4 \times 10^6 d_m n$ , phenolic resin cages are superior, although at lower speeds, our new polyamide resin cage shows less temperature rise. Presently, the limiting speed under grease lubrication is  $1.4 \times 10^6 d_m n$ .

The high-speed capabilities of cylindrical roller bearings were realized by applying new material technology of a new cage using polyether ether ketone (PEEK) material. PEEK resin was adopted for the ROBUST series cylindrical roller bearings because of resistance to high temperatures exceeding 300 °C, and its high-rigidity. Polyphenylene sulfide (PPS) resin cages, which are highly heat resistant and highly rigid, were developed for NSK's high-rigidity series of double row cylindrical roller bearings. Furthermore, NSK adopted injection-molding for production of these cages for lowering costs.

### 3.5 Development of lubrication methods

Lubrication is an important factor bringing out the performance of rolling bearings. In the 1970s, grease lubrication was mainly adopted for lathes. Since the

1980s, with the progress of high-speed operations for machining centers, micro-lubrication oil-air or oil-mist systems became popular. For spindles using high-pressure cutting fluid, oil-air and oil-mist are effective against intrusion of cutting fluid into the spindle. Although micro-lubrication systems for oil is currently mainstream, from a standpoint of maintenance, equipment simplification, and environmental concerns, a strong need for grease lubrication exists.

Grease lubricant life is heavily affected by operating temperatures. Fig. 14 confirms the excellent durability of grease used in NSK's low temperature rise ROBUST bearings. To ensure long grease life, it is important to reduce temperature rise along the rolling contact surface areas of the bearing. NSK has developed and marketed MTE grease, which increases reliability through improved pressure resistance at high operational speeds, and MTS grease, which uses a urea thickener, provides superior heat resistance for high-temperature conditions resulting from high-speed operations.

Under position preload and high-speed conditions, stress and temperature of the rolling surface become high. In order to maintain sufficient rigidity, the limiting speed for grease lubrication is  $1.4 \times 10^6 d_m n$ . NSK is currently in the process of developing an automatic grease replenishing system for higher speed ranges.

Ultra high-speed spindles draw an air curtain that prevents conventional oil-air and oil-mist micro-lubrication systems from injecting oil precisely into the bearing interior. NSK solved this problem by developing a super lean lubrication system that injects oil into the bearing interior at a high flow rate.

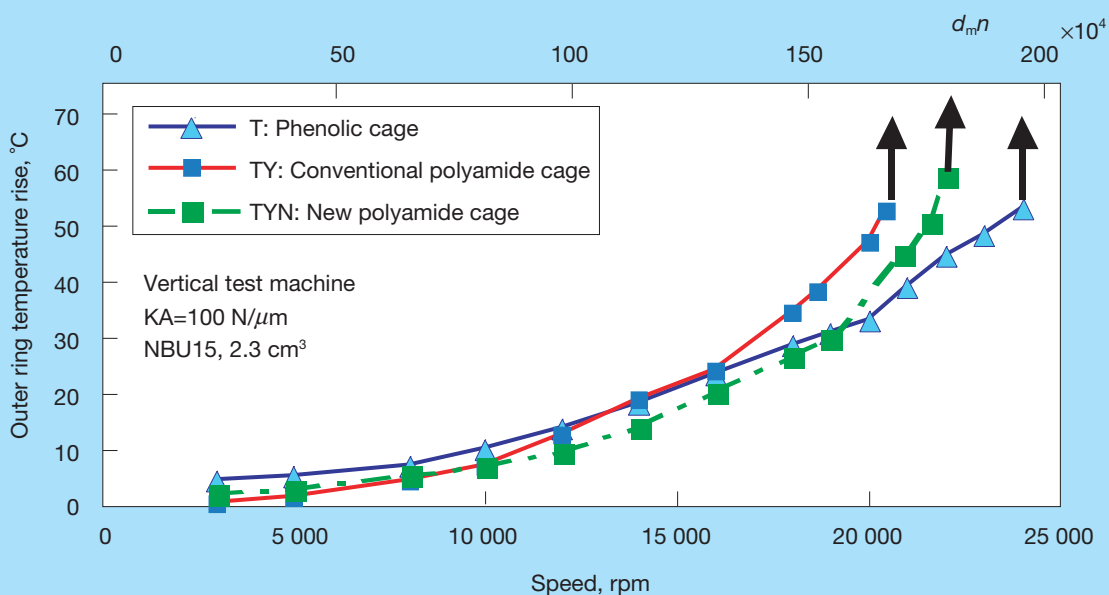

Fig. 13 Plastic cage test results

## 4. High-Accuracy Technology

Among the many stringent requirements that are being imposed on machine tools, the demand for even higher accuracy than before has become severe. Bearings for lathes used in manufacturing HDD components have required the highest levels of accuracy that can be obtained; component out-of-roundness cannot exceed  $0.2\ \mu\text{m}$ . Recently, requirements for greater accuracy have demanded that out-of-roundness be less than  $0.1\ \mu\text{m}$ . In lathes where the workpiece is rotated, non-repeatable runout poses a formidable challenge. NSK has developed running accuracy testing equipment and measuring equipment for determining the non-repeatable runout of the bearing, and to ensure accuracy of high precision bearings. We were able to achieve an out-of-roundness of the finished parts using machine tools, which use these angular contact ball bearings at less than  $0.2\ \mu\text{m}$ . Accuracy is further enhanced as we continue to focus attention on the precision of rollers in cylindrical roller bearings.

In machining centers where the tools are rotated, spindle runout becomes even more important. In high-accuracy machining centers, runout of  $15\ \mu\text{m}$  at the tip of a test bar is standard at the time of shipping. However, requirements are becoming more stringent. Therefore, the running accuracy of the bearings for machine tools must meet JIS Class 2, or better, in order to meet the demand

for higher accuracy at higher speeds.

Improving runout accuracy of the main shaft requires the following four items: higher accuracy of bearing peripheral components; improved assembly accuracy; improved dynamic runout accuracy; and paying careful attention to specific bearing mounting requirements and configurations. To develop and evaluate these high accuracy bearings, production processes, which assure sub-micron rotating accuracy, and the development of measuring equipment, are essential.

## 5. Responding to Environmental Needs

For the past several years, the machine tool industry has been placing more emphasis on environmental concerns, specifically energy conservation, environmental protection and pollution controls, and improved occupational and environmental health and safety.

Conventionally, high-speed spindles are lubricated with oil-mist and oil-air lubrication systems, which serve their purpose with assured reliability. However, as drawbacks to this system include oil particles that are suspended in the air of the operator's immediate area, large demand for continuously compressed air, and noise pollution, some machines have covers around the spindles as a solution. NSK's Spinshot™ II is a highly effective automated grease lubrication system that eliminates suspended oil particles, requires less volume of compressed air, and runs quieter.

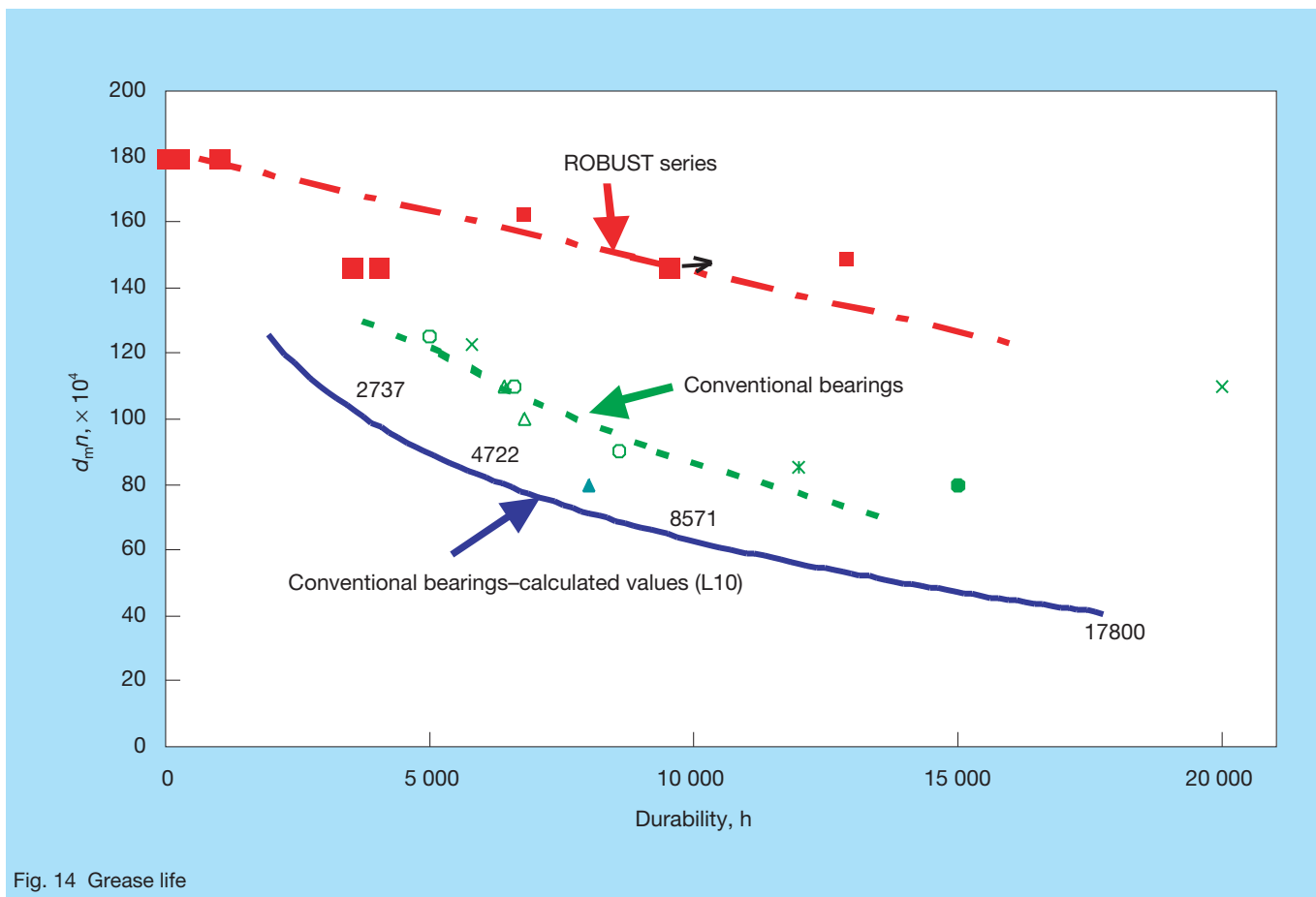

Fig. 14 Grease life

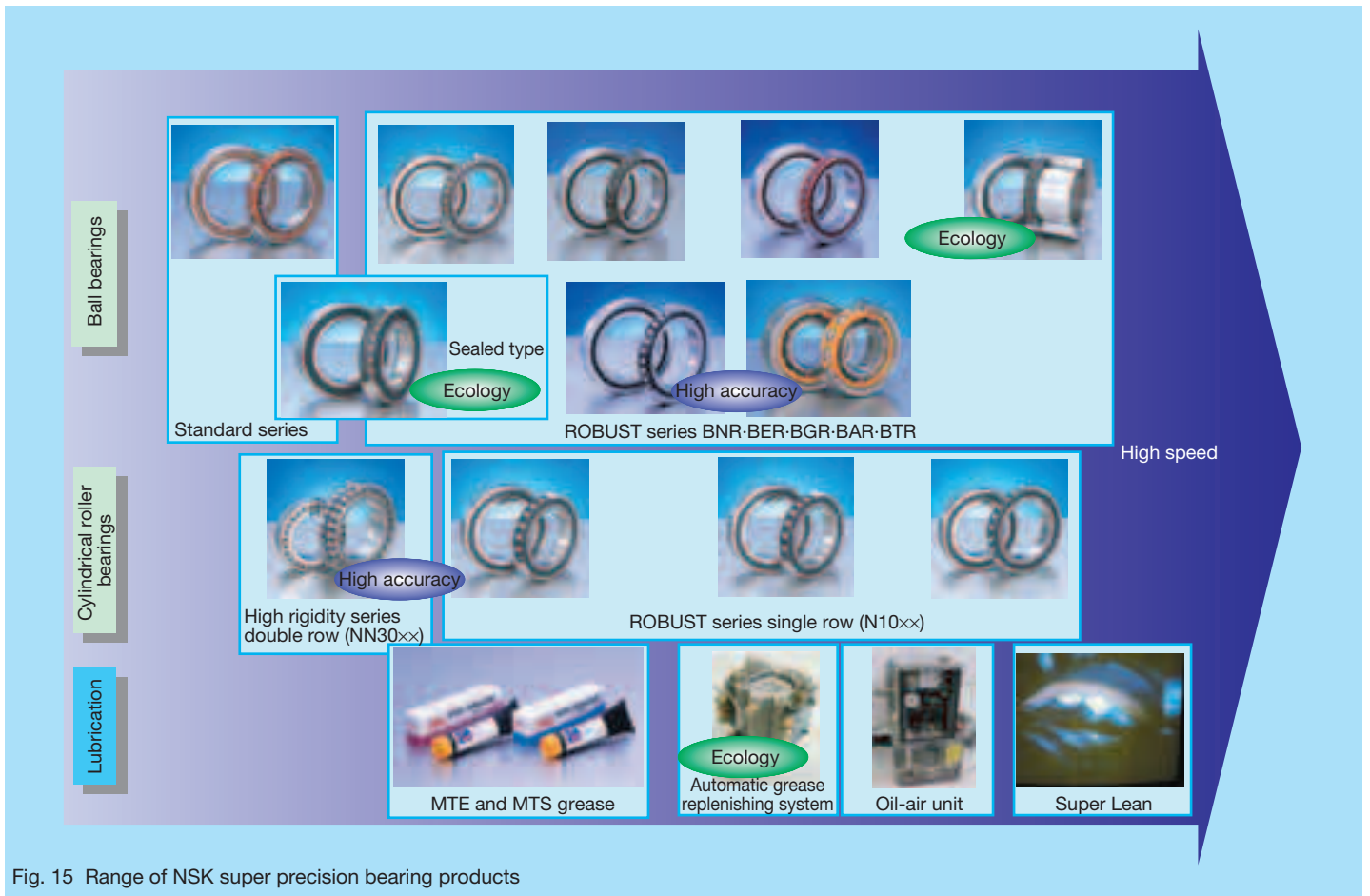

Fig. 15 Range of NSK super precision bearing products

NSK has also taken steps to minimize environmental pollution and prevent contamination from grease leakage. While also improving workability, we developed sealed angular contact ball bearings for main spindles, and sealed angular contact thrust ball bearings for ball screw supports.

## 6. Conclusion

As the machines that were exhibited at JIMTOF 2002 show that the requirements for machine tools have expanded to include higher speeds, greater accuracy, higher functionality, improved energy conservation, ecological and environmental friendliness, and enhanced cost performance. NSK has responded with precision bearings for machine tools and peripheral products as shown in

Fig. 15. For further details, please refer to the NSK Super Precision Bearings catalog, No. E1254.

We would like to contribute to the evolution of the machine tool industry, by developing products that provide new value.



*Shinji Nishibata*

# Development of Integrated Motor Spindle Unit for Machine Tools Using Automatic Grease Replenishing System

Mitsuho Aoki, *NSK Precision Co., Ltd.*  
Yasushi Morita, *Bearing Technology Center*

## ABSTRACT

Since the 21st Japan International Machine Tool Fair (JIMTOF 2002), competition among makers for faster high-speed machine tool spindles has become less intense. The focus of machine tools seems to have changed to ecological and environmental issues. NSK has thus developed a new spindle with an integrated motor that adheres to four concepts:

- Increased rotational speed with grease lubrication
- High rigidity and cutting performance at any speed
- User-friendly and maintenance-free
- Trouble-free operations

We also developed an automatic grease replenishing system for our machine tool spindle in order to achieve these concepts. Features of this spindle include:

- Continuous replenishment of grease lubricant
- Six rows of position-preloaded bearings (Bore diameter: 70 mm)
- All-in-one spindle with various support equipment
- High reliability

NSK machine tool spindles are doing well in the marketplace with unprecedented performance. Product specifications are as follows:

- Spindle taper: #40/HSK-A63
- Maximum speed: 20 000 rpm
- Bearing bore diameter: 70 mm
- Grease lubrication

We conducted grease discharge testing, heavy-cut testing, coolant resistance testing, and bearing endurance testing to confirm the effectiveness of our spindle design. All tests showed favorable results. We supplied this spindle to several customers and received positive comments regarding product performance and customer satisfaction.

## 1. Introduction

In addition to high accuracy, greater efficiency is one of the most important factors in the development of machine tool—or more specifically, improved productivity. Regardless of actual processing and non-processing time, shortening overall time has been a big mission for development engineers. Conversely, global-scale environmental issues are also a major focus because machine tools are required to be environmentally sound. Furthermore, machine tools must provide high-functionality with short delivery times due to growing global competition. To satisfy these needs, NSK has developed and marketed the NSK highly functional high-speed all-in-one spindle unit.

## 2. Background of Development

### 2.1 Current status of spindle market

#### 2.1.1 Slowdown in trend of high-speed machine tool spindles

The rotating speeds of milling spindles have increased from year to year. The spindles with ISO-40 equivalent nose taper exhibited at JIMTOF 2000 showed speeds of more than 20 000 rpm. However, JIMTOF 2002 revealed very little change in rotating speeds of machines compared to the previous tool fair in 2000. Achieving higher speeds is much more technically difficult to a point where the ends do not justify the means. Rather, enhancing value by lowering noise levels, reducing vibrations, and improving reliability at current speeds are what is in demand.

#### 2.1.2 Environmental awareness

Greater sensitivity to environmental concerns in manufacturing is receiving more emphasis from businesses. Machine tools also are becoming more active in lessening their environmental impact by reducing the amount of required lubrication oil and electrical consumption, as well as drastically minimizing coolant consumption by MQL.

### 2.1.3 Highly functional spindles

The demand for a wide range of functions in a spindle from rough to fine machining has existed for quite some time. For example, some makers advertise spindles that provide variable preload and shaft center cooling, but they are expensive thus making them unpopular.

### 2.1.4 All-in-one spindle

Until now, machine tool makers purchased machine tool spindles separately from other basic components. The makers often had to design, procure, assemble, and alter some of the basic components in order to create a finished product. Further examples of the more critical components include:

- Motor
- Tool clamping unit
- Tool releasing cylinder
- Clamping monitor
- Rotary union for through-the-spindle coolant
- Flood coolant nozzle  
(mainly for horizontal-type machining center)

Whereas short delivery times remain a formidable challenge for machine tool makers, a user-friendly, all-in-one, highly functional, and compact machine tool spindle (Fig. 1) is extremely desirable.

### 2.1.5 Integrated motor

There are many types of driving systems for spindles, but from the aspect of high-speed and vibration, integrated motor spindles are becoming the mainstream. The advantages of a motor spindle include shorter machine tool assembly time since motor centering is not necessary,

a more compact spindle head, which is shorter by 30% in comparison to direct-coupled types, and the head center can be located closer to the center of gravity. Heat generated by the motor, which used to be a problem, has improved drastically by using the latest in electric current control technology.

### 2.2 Product concept

Based on the needs discussed earlier, NSK formed a project team for the purpose of bringing a highly functional spindle suited for 21st century to the marketplace. Our product concept, which will set a new global standard for motor spindle units in the future, includes the following four items while ensuring high functionality through unitization:

- Achieve high-speed operation with grease lubrication
- Maintain high-rigidity and cutting capability for low- to high-speed operations
- Ensure user-friendliness, maintenance-free performance
- Maintain high reliability

## 3. Features of Standard High-Speed Spindle

The following are the main features of our new standard high-speed spindle that help to make the previously mentioned concepts a reality.

- Adoption of an automatic grease replenishing system
- Six rows of position-preloaded bearings  
(Bore diameter: 70 mm)
- All-in-one package
- High reliability

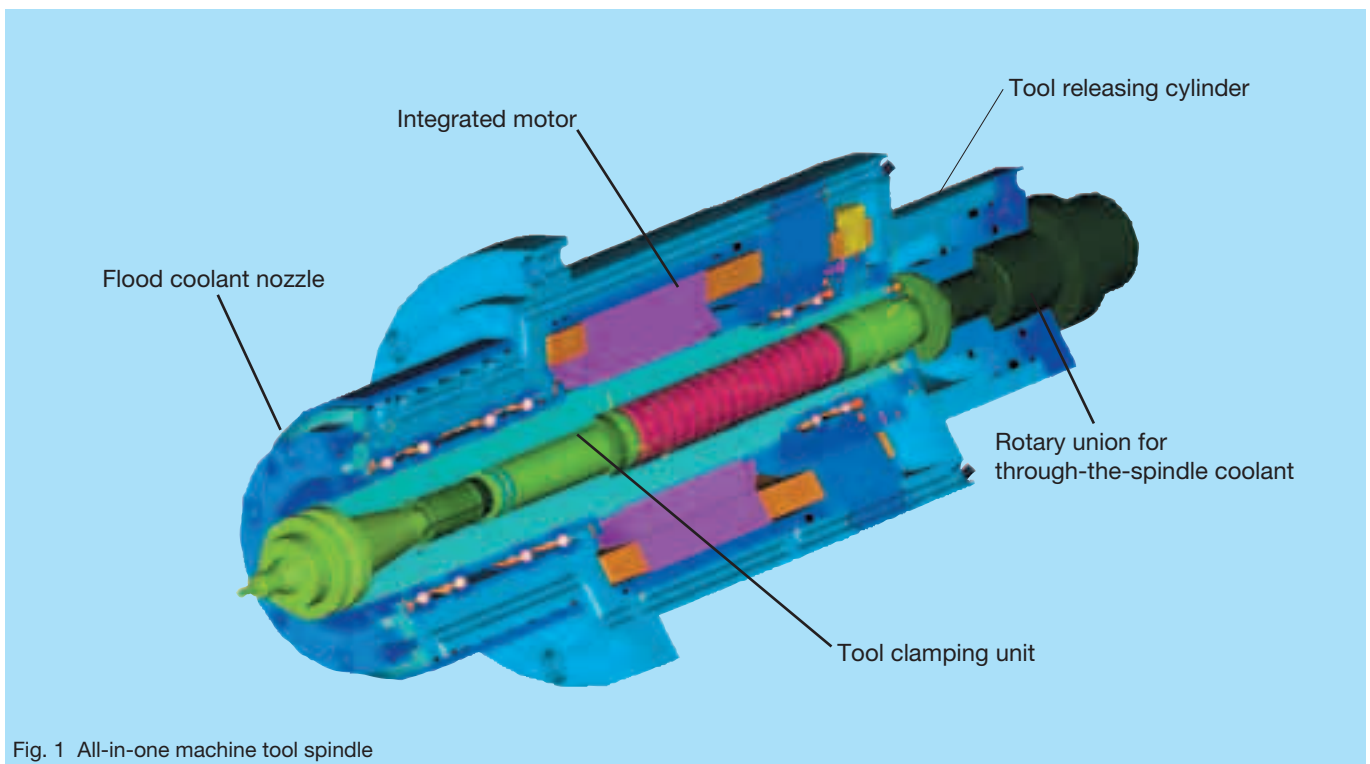

Fig. 1 All-in-one machine tool spindle

### 3.1 Adopting an automatic grease replenishing system

Primary features include high-speed performance ( $1.7 \times 10^6 d_m n$ ) under grease lubrication, a breakthrough specification for a spindle with the ISO-40 taper, operating speeds of up to 20 000 rpm, and 10 000 hour maintenance-free performance. The key innovation that proved indispensable in achieving these primary features was NSK's newly developed automatic grease replenishing system.

#### 3.1.1 Features of the automatic grease replenishing system

Table 1 shows the environmental advantages of using grease lubrication in comparison to oil-air lubrication.

We can see that the grease lubrication offers the following environmental advantages compared to the oil-air lubrication:

- Maintenance-free performance
- Conserves natural resources (minimal oil consumption)
- Improved working environment (no oil mist/reduced noise)
- Reduced energy consumption (lower need for compressed air)

Conversely, oil-air lubrication has following merits:

- Unhindered by grease-life problems related to high-speed operations
- Less affected by intrusion of coolant

The advantages of an oil-air lubrication system lie in the fact that it continuously provides a fresh supply of lubricant to components.

Our innovative grease replenishing system takes advantage of the positive aspects of both grease lubrication and oil-air lubrication. NSK has thus succeeded in developing and adopting this automatic grease replenishing system for new standard high-speed spindle units.

#### 3.1.2 Mechanism of the automatic grease replenishing system

##### (1) Grease supply

The grease replenishing unit (Fig. 2) delivers a small quantity of grease into the grease supply line that is connected to the spindle (Fig. 2). Compressed air provides the pressure to force grease through the grease supply line to a hole on the outer ring where the grease fills the bearing interior. The automatic grease replenishing system consists of a piston pump and grease tank.

The pump intermittently feeds small, fixed quantities of grease ( $0.01\text{--}0.03 \text{ cm}^3$ ) to the grease supply line. A critical factor of this system is the ability to control the amount of grease fed into the supply line. Excessive amounts of grease fed during rotating speeds of 20 000 rpm will cause an abnormal temperature rise due to increased churning. Grease life is shortened by rotating speed and temperature rise, and so the required amount to be fed will vary according to rotating speeds. To ensure that only the optimal amount of grease is fed into the lubrication line, the piston pump feed-rate is automatically regulated according to spindle speed. Fig. 3 shows the marketed version of NSK's automatic grease replenishing system.

##### (2) Discharge of grease

Much like the constant and steady flow of fresh lubricant in an oil-air lubrication system, the proper discharge of used grease is a key factor in maintaining a smooth-running automatic grease replenishing system. Excessive grease can cause overheating and noise due to churning. Maintenance-free operation for 10 000 hours of a standard high-speed spindle was achieved by designing used-grease discharge spacers and used-grease reservoir grooves into the bearing housing (Fig. 4).

To confirm the effectiveness of this newly developed design, testing was conducted using an amount of grease equivalent to 10 000 hours of usage. Results showed grease had properly accumulated in the used-grease reservoir grooves while maintaining smooth operations free of heat buildup and excess noise.

### 3.2 Six rows of position-preloaded bearings

Our highly rigid bearing design is further enhanced by six rows of position-preloaded  $\phi 70$  bearings, which is a unique arrangement that can reach an unprecedented rotating speed of 20 000 rpm.

Table 1 Lubrication comparisons

	Automatic grease replenishing system	Packed grease	Oil-air lubrication
Maintenance-free	Yes	Yes	No (Requires replenishment)
Oil consumption	Minimal	Minimal	Large amounts
Oil particles suspended in air	None	None	Significant amounts
Compressed air requirement	Small amounts	Small amounts	Large amounts
Noise	Minimal	Minimal	High noise level
Grease life	N/A	Limited life	N/A
Coolant resistance	High	Low	High

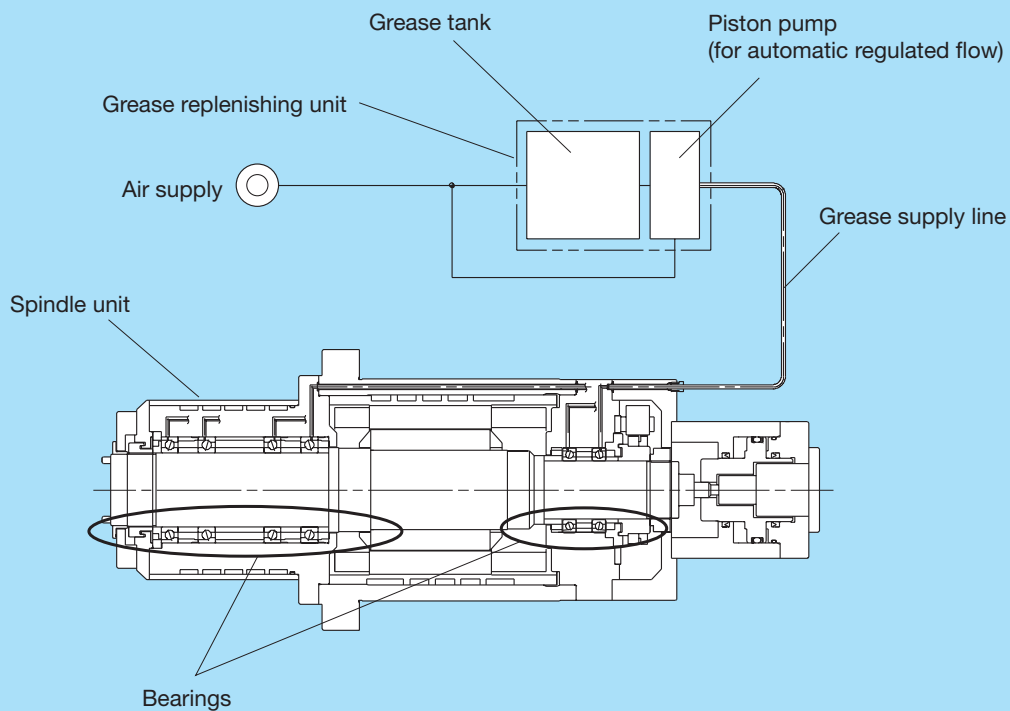

Fig. 2 Automatic grease replenishing system



Fig. 3 Automatic grease replenishing unit

### 3.2.1 Bearing specifications

The six rows of bearings, which work to ensure rigidity for a wide range of operations from low to high speeds, consist of a position-preloaded quadruplex set

arrangement (DBB) of angular contact ball bearings with a bore diameter of 70 mm located at the front side, and a back-to-back arrangement (DB) of angular contact ball bearings with a bore diameter of 55 mm is positioned on

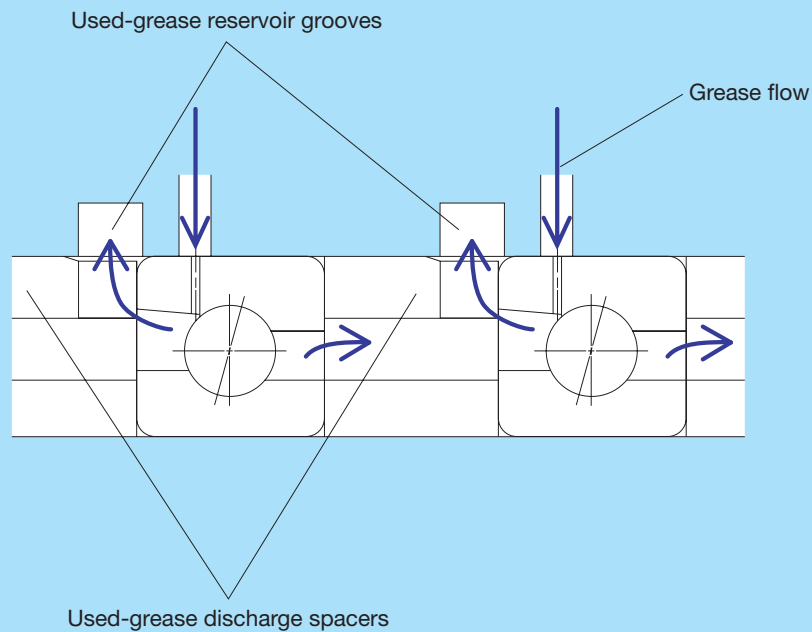

Fig. 4 Flow of used grease

Table 2 Bearing specifications

	Front side	Rear side
Type	70BNR19 series	55BNR19 series
Rolling element	Ceramic ball	Ceramic ball
Bearing bore diameter	$\phi 70$ mm	$\phi 55$ mm
$d_m n$ value	$1.7 \times 10^6$	$1.35 \times 10^6$
Combination	DBB (Quadruplex set arrangement)	DB (Back-to-back arrangement)
Lubrication method	Automatic grease replenishment	Automatic grease replenishment

Table 3 Cutting test results

Work material	S50C
Cutting tool	Face mill
Rotational speed (rpm)	1 200
Cutting width (mm)	70
Feeding speed (mm/min)	3 600
Cutting removal (cm <sup>3</sup> /min)	504
Condition of cut surface	Good

the supporting side. Further details are available in Table 2.

### 3.2.2 Cutting test results

Table 3 shows the results of cutting steel with the developed spindle unit that was installed on a vertical-type machining center. For face milling at 1 200 rpm, removal of more than 500 cm<sup>3</sup>/min was successful, which can be classified as a heavy cutting for conventional machine tool spindles whose maximum rotational speed is approximately 10 000 rpm.

## 3.3 All-in-one spindle unit with integrated functions

Further advantages are realized by adopting an all-in-one package that is user-friendly. Details follow below.

### 3.3.1 Tool clamping mechanism

NSK standard high-speed spindles include a tool clamping unit as standard equipment, and field balancing is performed for each assembly. Users can now eliminate troublesome tasks associated with procuring machine

spindles and drawbars separately, and benefit from shorter production times due to simpler assembly. Furthermore, this high-speed spindle is equipped with a clamping monitor that checks existence of a tool by position of the drawbar. The durability of drawbar is described later in Section 3.4.3.

### 3.3.2 Tool releasing cylinder

A tool releasing cylinder is standard equipment. Users require simply connecting the cylinder to a hydraulic pressure line. From an ecological standpoint, a hydropneumatic pressure booster can be used in lieu of hydraulic pressure for unclamping. The tool releasing cylinder also incorporates switches for upper and lower position limits.

### 3.3.3 Coolant function

Typical functions of coolant for machining centers include:

- Flood coolant
- Through-the-spindle coolant

- Overhead shower coolant
- Chip flush away coolant

NSK's standard high-speed spindle takes advantage of through-the-spindle and flood coolant systems. Benefits include prevention of heat buildup in the workpiece or cutting tool and flushing away of chips. Standard high-speed spindles can be fitted with either system as an option.

A rotary union (Fig. 5) supplies coolant under high pressure (maximum 7.0 MPa), which is fed through the top of the tool. This configuration is especially effective for deep-hole drilling. As users reduce their reliance on coolants and convert to semi-dry cutting, such as MQL processing, users can continue to use the rotary union as they adopt new processing methods.

Flood coolant for horizontal machining centers is discharged from six coolant outlet ports located on the spindle nose. As for vertical machining centers, coolants, other than flooding, tend to use external piping, which is usually located at the rear side of the spindle for easier assembly.

### 3.4 High reliability

In addition to the features previously discussed, NSK's standard high-speed spindle provides customers with high reliability against water exposure, and ensures bearing durability. High performance spindles with low reliability are unacceptable in the marketplace, especially in these times where users are more concerned with reliability than high performance. Here, the results of various tests

verify the reliability for a variety of components as described.

#### 3.4.1 Measures against coolant intrusion

Machine tool spindles are constantly operated under severe conditions, including being subjected to coolant splashing. Contact seals cannot be used, and so the problem of coolant intrusion is always a major factor in impairing reliability. Grease-packed spindles are especially vulnerable to coolant intrusion. Once the bearing becomes contaminated, the lack of a fresh lubricant supply causes the grease to deteriorate, which can lead to rapid bearing failure. NSK's standard high-speed spindle solves this problem by using a quadruple seal and grease replenishing system.

##### (1) Seal design

Fig. 6 shows the basic layout of a quadruple seal. The first stage seal incorporates a chip and coolant slinger for preventing fluids and particles from entering the bearing by rotary motion. Additional protection is achieved by an air barrier, which is created by air blown into the labyrinth that then flows outward from the slinger. This air barrier can provide effective sealing against external contamination. Whereas contact seals are not feasible in high-speed applications, labyrinth seals are used instead for the third stage. The final feature is a sealing spacer. The sealing spacer consists of a bearing rubber seal (non-contact type), which is inserted in the bearing spacer for sealing the bearing, is compact, and is free of any space requirements in the axial direction. Since our standard



Fig. 5 Rotary union

high-speed spindle adopts an automatic grease replenishing system, grease is not washed away even if coolant intrudes into the bearing interior giving it the same level of reliability as that of oil-air lubrication.

(2) Water resistance test

In order to verify the effect of measures against coolant, testing was conducted with high-pressure coolant (7 MPa) being discharged from the top of the tool and splashed to the end of the nose. Fig. 7 illustrates coolant flow and a photograph of the test equipment. Test results showed no intrusion of coolant, thus confirming that our seal design

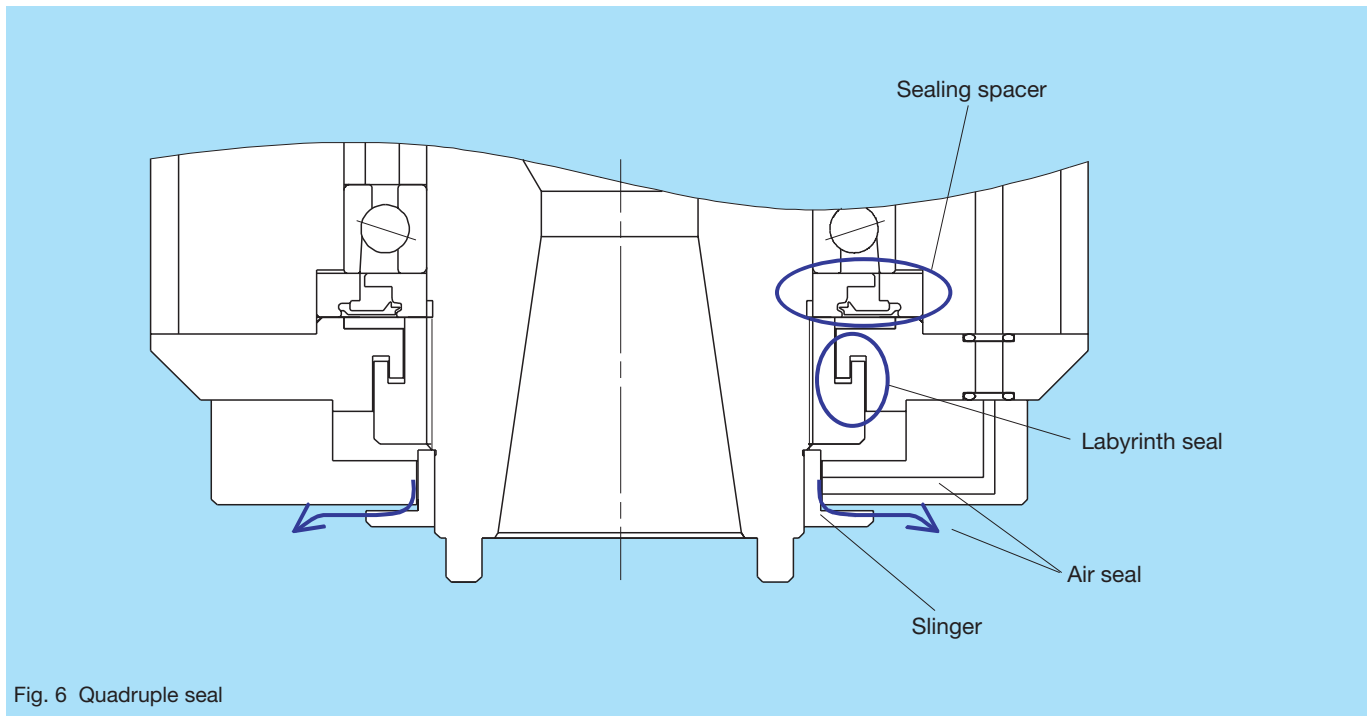

Fig. 6 Quadruple seal

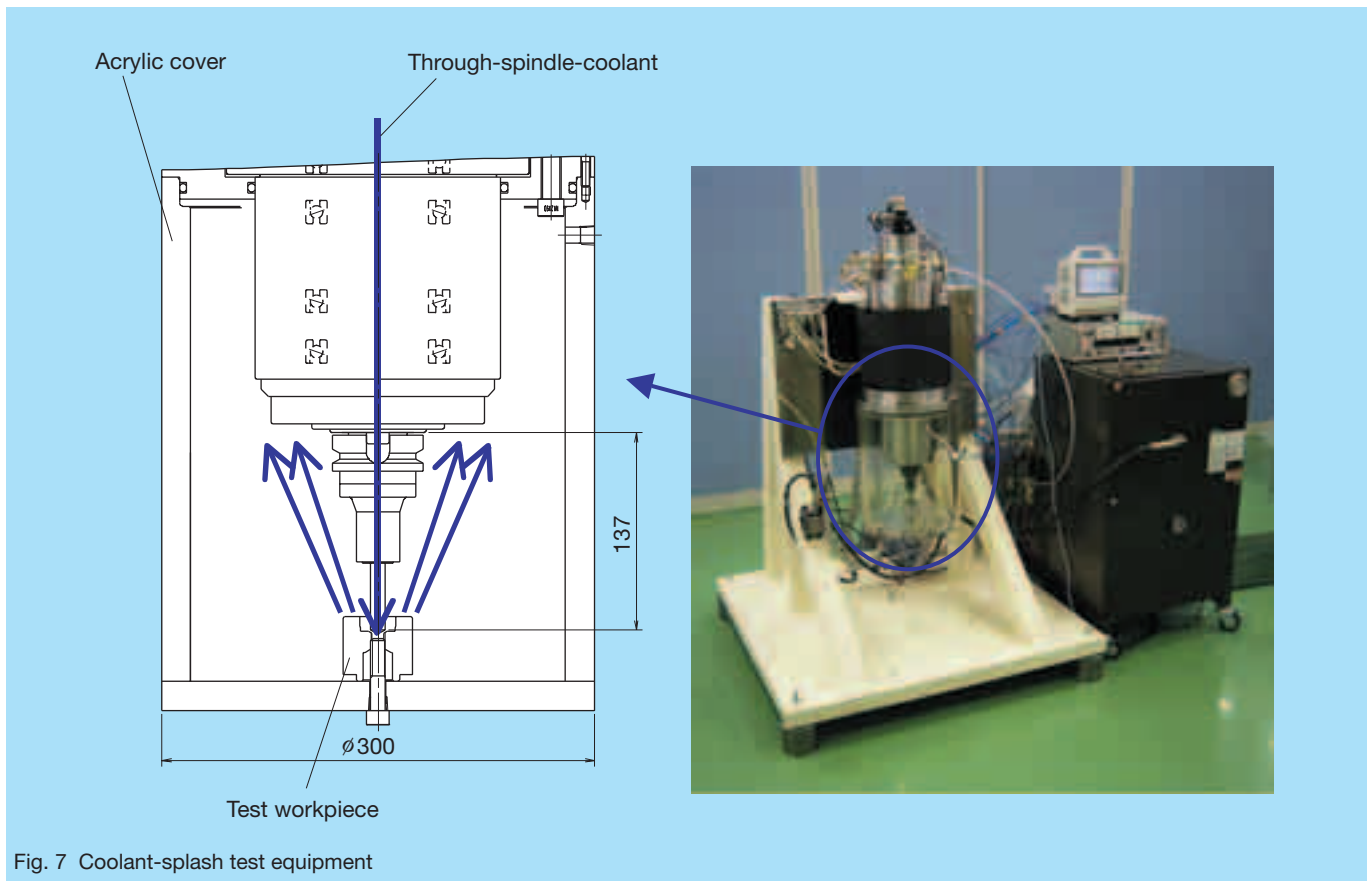

Fig. 7 Coolant-splash test equipment

can sufficiently withstand real-world applications.

### 3.4.2 Bearing durability

Bearing reliability is one of the most important factors for machine tool spindles. We conducted rapid acceleration/deceleration tests and radial load tests to confirm bearing endurance.

#### (1) Rapid acceleration/deceleration test

By heating the integrated motor with rapid acceleration/deceleration cycles (Fig. 8), bearing durability under thermal loads was tested. After continuous running in excess of 3 000 hours, no abnormalities such as noise or seizure occurred and rotation remained stable.

#### (2) Radial load test

Testing consisted of a radial load (500 to 2 000 N) applied at the tip of the spindle (115 mm from the gage line), and continuous rotation at a maximum speed of 20 000 rpm. The 2 000 N radial load was about two times of the radial load 1 100 N that is applied to the outer diameter of an end mill ( $\phi$ 20 mm) as tangential force under a maximum torque of 11 N·m at 20 000 rpm. Test results (Fig. 9) confirm a slight temperature rise with stable rotation.

### 3.4.3 Draw bar endurance test

Tool clamping unit commonly incorporate a draw bar with a disk spring. Life of the disk spring, however, is relatively short and can cause some unbalance that makes it inappropriate for high-speed spindles. NSK's standard high-speed spindle uses a spiral disk spring that eliminates and balances any defects. Repeated clamp/unclamp testing of the draw bar was conducted

on an actual machine, which passed the targeted two million cycles.

## 4. Specifications of Standard High-Speed Spindle

### 4.1 Specifications

We have developed four different models based on motor output and maximum speed (Table 4). Models vary for motor output (type L and type S), and maximum speed of motor output (15 000 rpm and 20 000 rpm). Customers can also select #40 or HSK-A63 for all four models.

### 4.2 Boundary dimensions

Housing outside diameter of either  $\phi$ 230 mm (type L) or  $\phi$ 210 mm (type S) is available (Fig.10). These diameters provide easy-to-use dimensions for these classes of spindle. Applications include vertical or horizontal types. Both types include a slim nose diameter ( $\phi$ 170 mm) designed to ensure smooth processing of the bottom of a vertical wall and will not interfere with the table in a horizontal machining center.

## 5. Standard High-Speed Spindle Performance

Table 5 illustrates the excellent test results of NSK's standard high-speed spindle. Performance requirements as the new generation spindle are clearly met in accordance with the specifications given in Table 4. Thermal displacement is controlled at a lower level by adoption of a cool-running motor, which enables easier thermal displacement compensation by machine tool manufacturers.

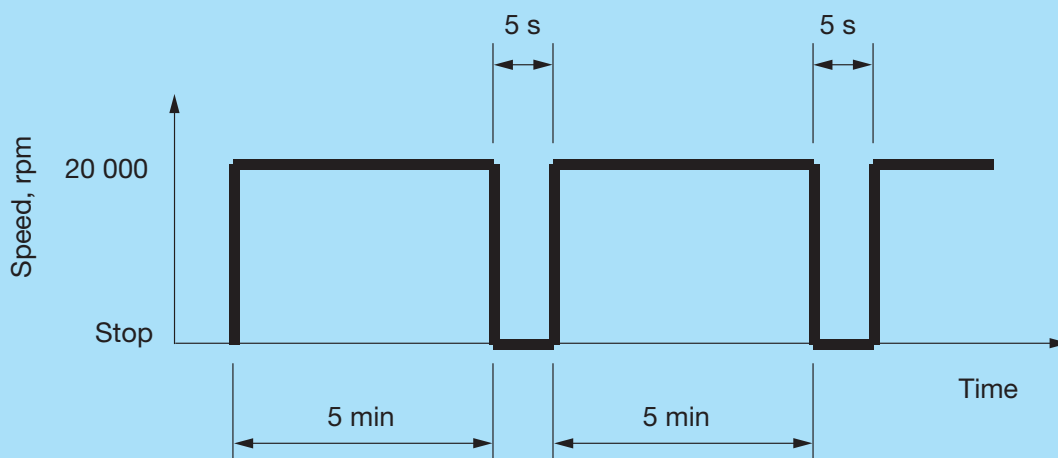

Fig. 8 Rapid acceleration/deceleration cycles

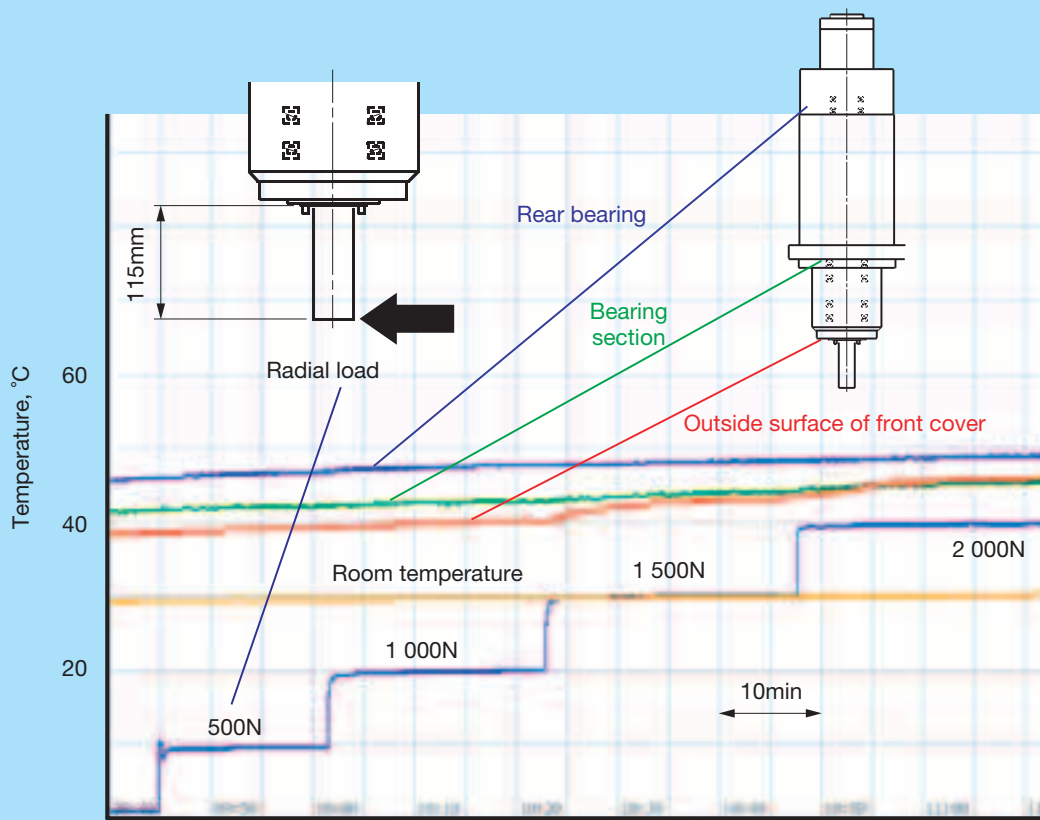
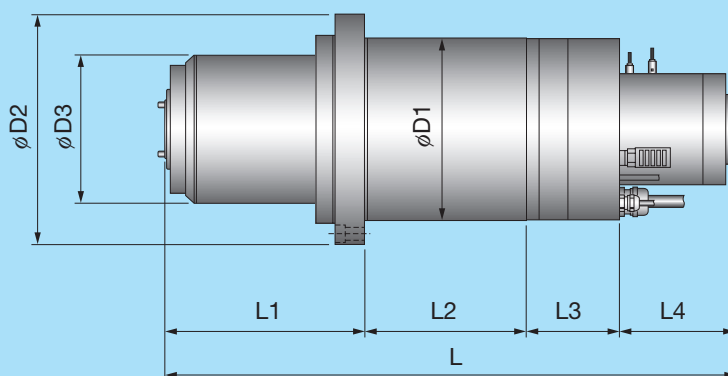
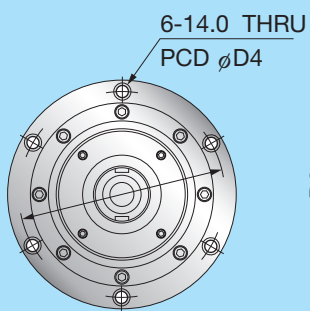

Fig. 9 Radial load test results



	Type S	Type L
L	670	800
L1	235	235
L2	190	320
L3	110	110
L4	135	135
D1	210	230
D2	265	285
D3	170	170
D4	240	260

Fig. 10 Boundary dimensions

Table 4 Specifications

Spindle Model	S/15000	S/20000	L/15000	L/20000
Main specification				
Application	Machining center		Machining center	
Mounting position	Vertical and horizontal		Vertical and horizontal	
Maximum speed	15 000 rpm	20 000 rpm	15 000 rpm	20 000 rpm
Rotating direction	Both directions		Both directions	
Boundary dimension				
Outer diameter of cylinder	φ210 mm		φ230 mm	
Mass	120 kg		170 kg	
Mounting bolt size	6 × M12		6 × M12	
Mounting bolt P.C.D.	φ240 equally spaced		φ260 equally spaced	
Type of integrated motor				
Motor model	α112S/20000iB		α112L/20000iB	
Maximum output	11/18.5 kW (Continuous/10 min)		18.5/22 kW (Continuous/25%)	
Maximum torque	60.5 N·m (15%)		118 N·m (25%)	
Bearings				
Front	NSK 70BNR series		NSK 70BNR series	
Rear	NSK 55BNR series		NSK 55BNR series	
Specification of lubrication				
Lubrication method	Packed grease	Automatic grease replenishment	Packed grease	Automatic grease replenishment
Grease type	NSK MTE grease		NSK MTE grease	
Rotating accuracy				
Runout of test bar bottom	3 μm or lower		3 μm or lower	
Runout of test bar at 300 mm	10 μm or lower		10 μm or lower	
Vibration class	V3		V3	
Tool shank + Pull stud				
JIS	Tool shank: 40T	Pull stud: 40P	Tool shank: 40T	Pull stud: 40P
DIN	Tool shank: #40	Pull stud: #40	Tool shank: #40	Pull stud: #40

Table 5 Results of basic tests of spindles

Items		Type S	Type L
Runout of test bar	Bottom	2 μm	3 μm
	Top	7 μm	8 μm
Axial rigidity		90 N/μm	90 N/μm
Vibration at	20 000 rpm	0.8/1.2 μmP-P	0.9/1.8 μmP-P
Noise level		74 dB	76 dB
Acceleration and deceleration time	Start (0 → 20 000 rpm)	3.9 s	3.2 s
	Stop (20 000 rpm → 0)	4.1 s	2.5 s
Temperature rise (At room temperature)	Front	Average 15 °C	Average 13 °C
	Rear	Average 17 °C	Average 18 °C
Thermal displacement at (Elongation in Z direction)	15 000 rpm	33 μm	28 μm
	20 000 rpm	59 μm	60 μm
Compressed air requirements		50 L/min (Normal)	50 L/min (Normal)

---

## 6. Conclusion

NSK's standard high-speed spindles are used mostly by machine tool makers throughout Asia. NSK has received high commendations from end-users regarding the advantages of using this spindle. Also, use of these spindles benefits standardization of users products. As we work to make upgrades to our current models for even better performance and reliability, we hope to make NSK's standard high-speed spindle the global standard.



*Mitsuho Aoki*



*Yasushi Morita*

# Development of High-Speed and Low-Noise Ball Screws

Masato Kato  
NSK Precision Co., Ltd.

## ABSTRACT

NSK has developed and marketed a new series of high-speed, low-noise ball screws for machine tools: the HMC-B02 series. In addition to featuring less noise emission, lower vibration, and better tone quality, a newly designed ball recirculation mechanism and other newly designed components have contributed to development of an innovative product that ensures 1.63 times higher speed than conventional ball screws for machine tools. The HMC-B02 series is the top solution for extremely high-speed applications for which linear motors have been dominant.

## 1. Introduction

It has been more than 40 years since NSK delivered its first ball screw to a machine tool company back in 1961. Since then, machine tools have continued to evolve with the development of numerical control (NC). In addition, ball screws, which are main component of machine tool feeding mechanisms, have also experienced repeated upgrading in a neck-and-neck race with that of machine tools. Among the many improvements made in machine tools, remarkable progress has been made in high-speed operations for improving machining efficiency. Examples include faster speeds of main spindles, rapid traversing speeds, and faster feeds of the cutting tool.

A look at machine tools on display at the Japan International Machine Tool Fairs (JIMTOF) over the past

several years reveal an interesting trend regarding rapid traverse speeds (Fig. 1). At present, rapid traverse speeds of 50-60 m/min for machining centers have become rather common, while maximum traverse speeds can exceed 100 m/min. NSK has been constantly developing high-speed ball screws in an effort to “stay one step ahead” of market needs. In order to comply with continual demand for faster speed, and to provide a user-friendly product to maintain our competitive position with linear motors that are presently in the market, we have worked to further develop ball screws with even higher speeds.

However, achieving high-speeds is only one of several issues that must be addressed. It is difficult to say that real high-speed operation is achieved by only improving the rapid traverse speed. Simultaneously, it is important to reduce noise and vibrations, which tend to worsen at

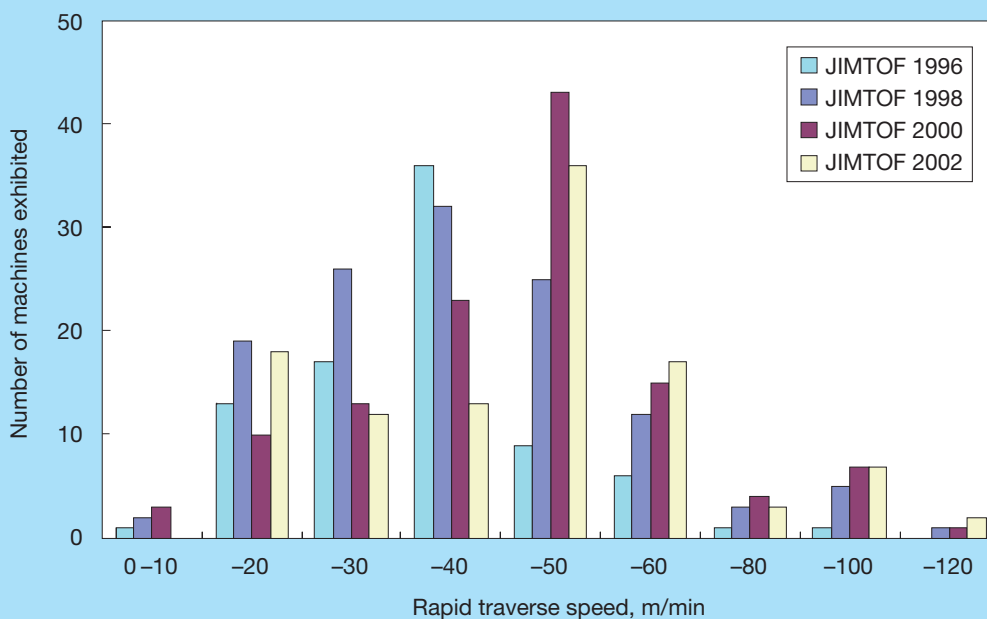

Fig. 1 Rapid traverse speed for machining centers



Photo 1 HMC-B02 series

faster operating speeds. Although we have traditionally worked to minimize vibrations and to ensure quiet operations of ball screws, greater awareness of the impact ball screws can have on the health and safety of the operators environment have lead to a stronger commitment by manufacturers to ensure a quieter and smoother operating product. Keeping these factors in mind, NSK has developed and successfully marketed the HMC-B02 series of high-speed and low-noise ball screws (Photo 1). The HMC-B02 series was developed with the concept of quieter operations and less vibration than conventional ball screws while ensuring even higher speeds.

## 2. Features

Based on NSK's HMC series, we developed the HMC-B02 series by adding several new features and made improvements for enhanced speed and quieter operation.

One of the major differences between the HMC-B02 series and conventional series is the recirculation circuit. This circuit consists of a mechanism in which steel balls are circulated infinitely to enable an infinite stroke theoretically. Naturally, the balls are forced to change their circulating direction at the point between the loaded and unloaded zones, resulting in irregular movement of the balls, which has a detrimental effect on ball screw performance.

It is with the HMC-B02 series that NSK has developed a new method for recirculating the balls, which we call an "end-deflector." Our end-deflector replaces the conventional return tube circuit, thus allowing the smoothest ever flow of balls between the loaded and unloaded zones of the spiral groove and recirculation

circuit, which have greatly contributed to the excellent features discussed below.

### 2.1 Improved high-speed rotating capability

To achieve high-speed feeding using a ball screw, there were many challenging tasks that we were faced with. First, we had to focus on how to increase rotational speed. Presently, increasing feed speed is accomplished by increasing rotational speed or screw lead. Therefore, many modern machine tools tend to have ball screws with a large lead. In the HMC-B02 series, however, we focused initially on increasing rotational speed with an emphasis on maintaining a positive balance between lead and rotational speed.

In conventional recirculation circuits with return tubes, the limiting factor of maximum rotational speed depends on fatigue resistance of the return tube. When balls are scooped in the return tube, the balls repeatedly strike the tip of return tube causing damage and eventual material fatigue. Therefore, previous return tube designs focused on dispersing the stress and on improving strength by increasing thickness of the return tube walls.

NSK's HMC-B02 series takes a different approach by adopting an end-deflector that scoops each ball smoothly along the direction of the facing. The amount of force exerted by the balls on the recirculation component was significantly reduced thus enabling high-speed rotation exponentially.

High-speed rotation of ball screws is expressed as a  $d \cdot n$  value, where  $d$  is the screw shaft diameter (mm), and  $n$  is the rotational speed (rpm). The upper limit of the  $d \cdot n$  value for NSK's conventional HMC series is  $13.5 \times 10^4$ , while the HMC-B02 series show a marked increase in  $d \cdot n$  value at  $22 \times 10^4$ . For example, conventional ball screws

with a shaft diameter of 40 mm have an upper limit of 3 400 rpm; our new series increases the speed to 5 500 rpm.

Always looking to the future, NSK is currently assessing our high-speed rotation capabilities of this series, and conducting high-speed tests under various conditions. Laboratory results thus far have shown speeds exceeding a d-n value of  $25 \times 10^4$ .

## 2.2 Reduced noise and vibration

Noise and vibration, which tend to increase with higher speeds, must be reduced in order to achieve higher rotational speeds.

There are two types of noise that are generated in ball screws: noise generated by rolling balls on the raceway grooves in the loaded zone, and ball recirculation noise generated as the balls change direction at the entry and exit points of the unloaded zone. In case of medium- and large-sized ball screws for machine tools, the ball recirculation noise is the dominant noise source.

The energy of the balls striking other components at the entry and exit of the unloaded zone excites the ball screw, and thus generates noise. The HMC-B02 series incorporates a newly designed recirculation circuit that drastically reduces noise and vibration by suppressing the vibration energy.

Noise and vibration measurements taken of the HMC-B02 series and the conventional HMC series are described below. Vibration was measured with an acceleration pickup attached to the nut end face in the axial direction, while a microphone was positioned 400 mm from the shaft center to measure noise (Fig. 2). Testing was conducted using a ball screw with a 40 mm diameter shaft, a 20 mm lead, no seal, and ISO VG #68 lubricating oil.

A comparison of noise level measurements (Fig. 3) shows an average value for NSK precision ball screws. The formula used to obtain the average value is based on years of empirical data, and is the standard for evaluating noise levels of NSK ball screws. We can see that noise levels of conventional ball screw series are close to the overall average value. Remarkably, the HMC-B02 series shows noise levels far lower than that of conventional series by as much as five to seven decibels. Furthermore, comparisons of noise levels involving rotational speed while operating at 2 500 rpm show equivalent noise levels where conventional series are operating at a much lower speed of 1 500 rpm. The HMC-B02 series clearly provides users with higher speeds without the higher noise levels. Another interesting approach is to compare the number of ball screws. If the number of ball screws is doubled, noise levels increase to three decibels. If the number of ball screws is quadrupled, the noise level then increases to six decibels. Theoretically, the HMC-B02 series are so quiet that it takes four sets to equal the noise level of only one set of conventional ball screws.

Taking a closer look at data shown in Fig. 3, frequency analysis of noise at a speed of 2 500 rpm (Fig. 4) in comparison to conventional series shows that the HMC-B02 series is much quieter, especially in the high frequency zone. Noise levels are not only drastically reduced, but are also much more tolerable for the operator.

Using shields and covers can reduce the level of noise coming from a ball screw, but these do not address the problem of vibrations that are the original source of noise. The HMC-B02 series addresses the problem of vibrations, and in comparison to conventional products, noise and vibrations are drastically reduced. Results of frequency

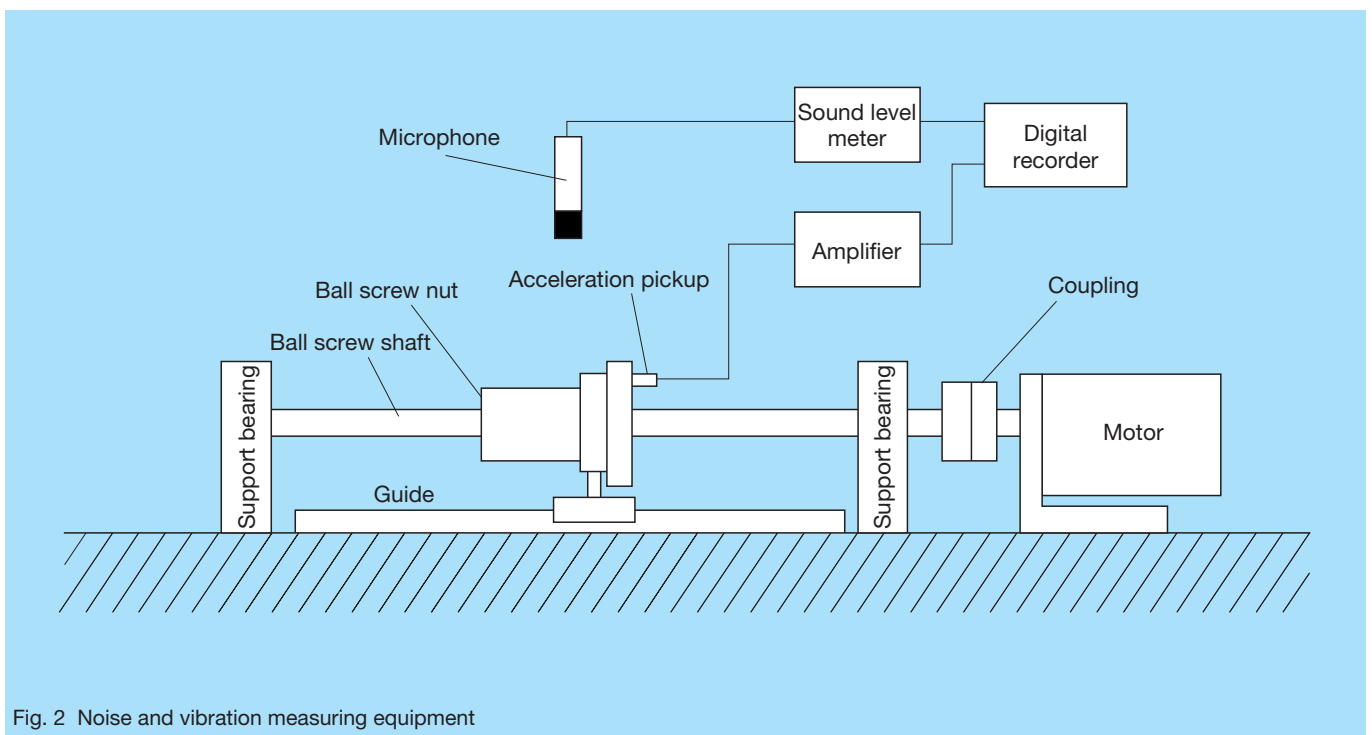

Fig. 2 Noise and vibration measuring equipment

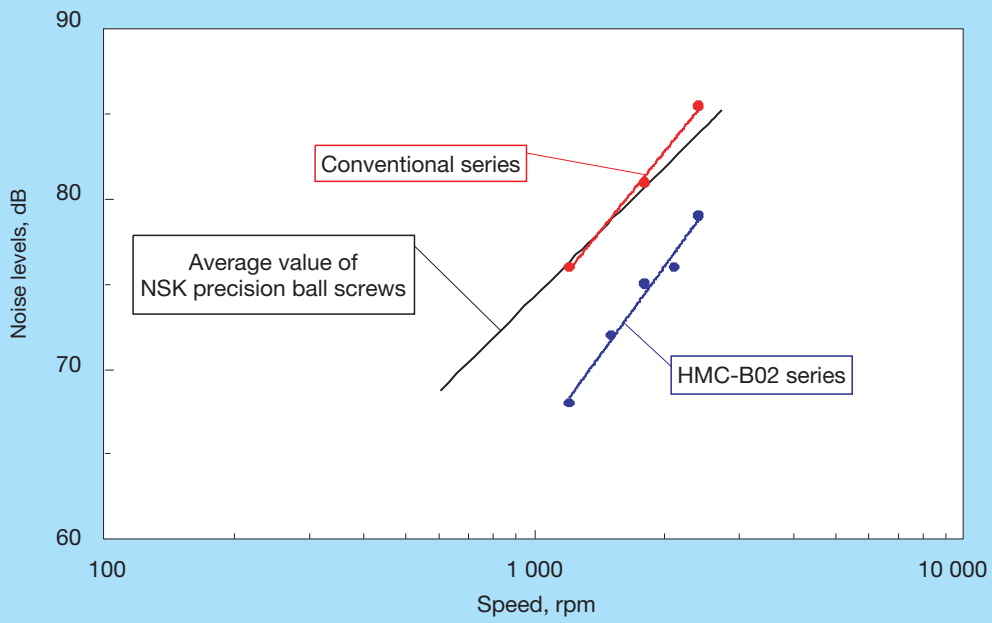

Fig. 3 Noise levels

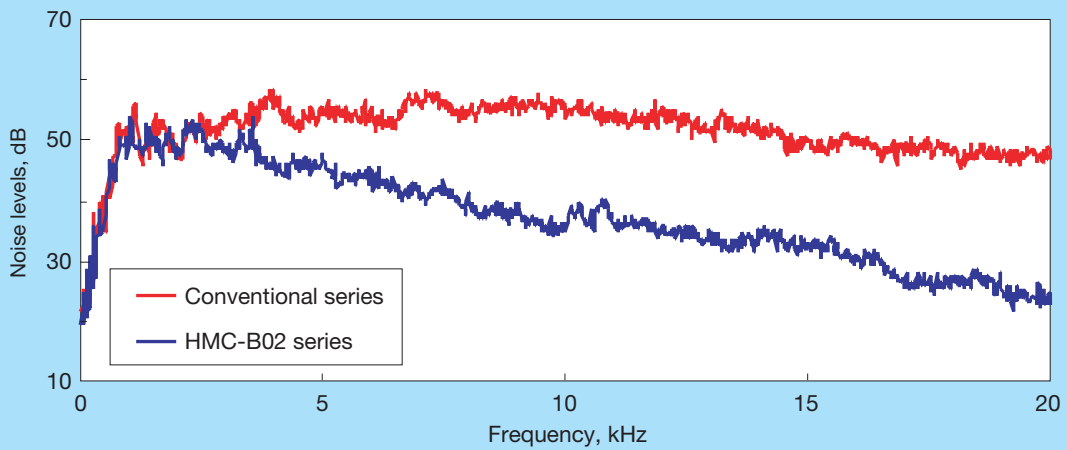

Fig. 4 Noise frequency analysis

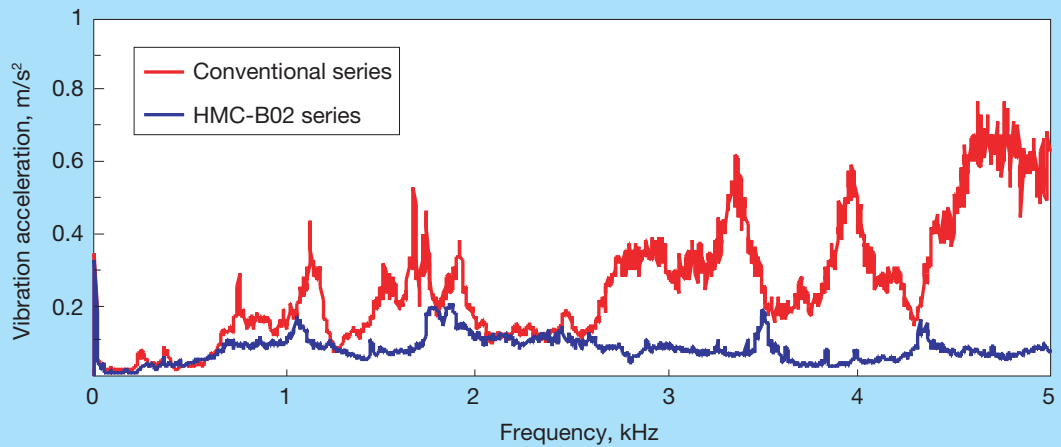

Fig. 5 Vibration frequency analysis

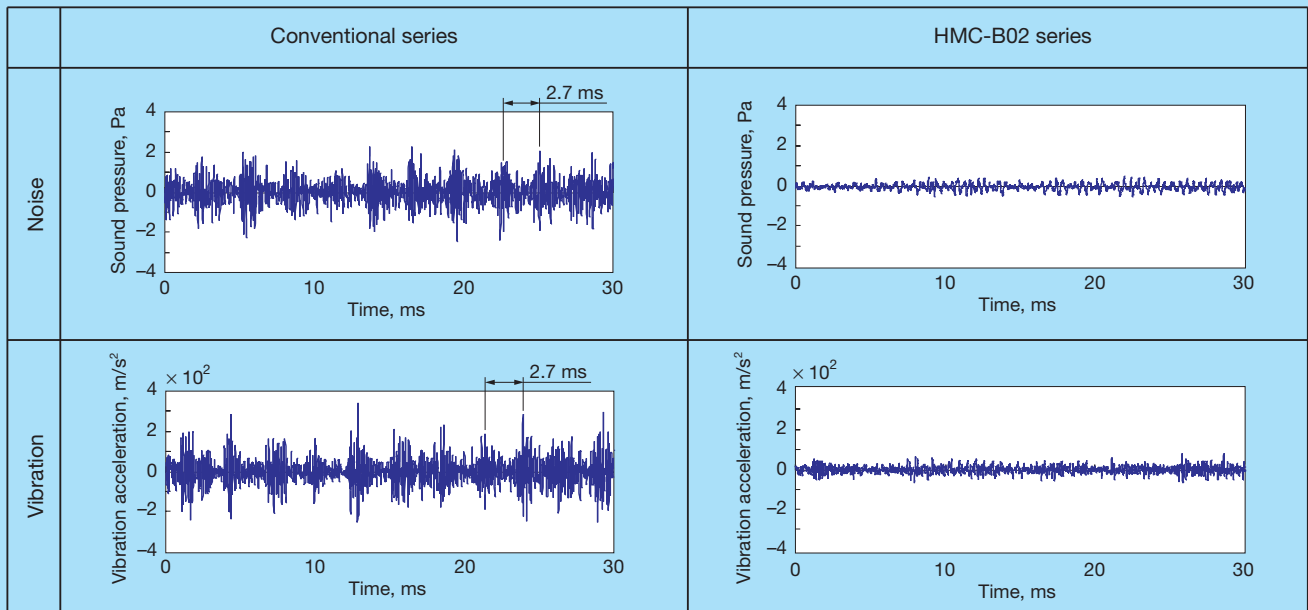
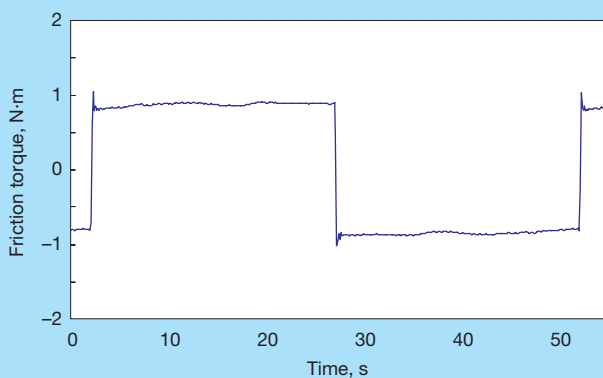
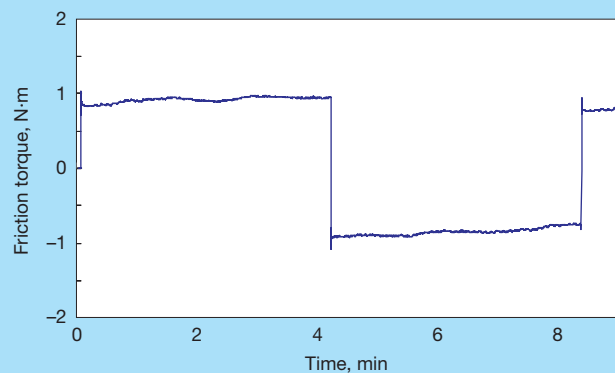

Fig. 6 Waveform of noise and vibration



(a) Speed, 100 rpm



(b) Speed, 10 rpm

Fig. 7 Friction torque

analysis of vibration are shown in Fig. 5.

The waveforms shown in Fig. 6 reveal that the conventional series has an increase of noise and vibration at 2.7 ms intervals, which is equivalent to one cycle of a ball passing. The HMC-B02 series, however, has such low levels of noise and vibration that they are almost insignificant and difficult to even measure. These results confirm that the HMC-B02 series has significantly less vibration, less noise, and more compatible with the operators working environment due to the smoother ball recirculation circuit.

### 2.3 Improved operating characteristics

Friction torque stability is one of the most important properties to ensure high-accuracy. Operating characteristics of a ball screw when it is being driven include friction torque stability for both large and small torque fluctuations.

Examples of measured friction torque are shown in Fig. 7. The test sample consisted of a ball screw with a 40 mm diameter shaft and a 20 mm lead operated under ISO VG #68 lubrication oil. The 100 rpm speed for Fig. 7 (a) is a standard condition for evaluating friction torque. Rotational speed was set at 10 rpm for Fig. 7 (b) where

friction torque tends to fluctuate to exemplify low speed operations.

Fig. 7 shows the effectiveness of smooth movement of balls at the connected section between the rolling groove and the recirculation circuit. Even at a speed of 10 rpm, operating characteristics are good with extremely small torque fluctuation.

Oscillation, which is the repeated motion of small strokes at less than two to three rotations, is often repeated in precision machinery. If a ball screw repeats oscillation from several cycles to high number of cycles, the absolute value of friction torque or torque fluctuations tend to gradually increase. In some cases, friction torque can increase up to 200 percent. The ball screw we used for friction torque testing (Fig. 7) was oscillated for 100 cycles at a speed of 10 rpm, and a stroke of 15 mm (0.75 rotation of screw shaft). The friction torque data for this oscillation (Fig. 8) showed extremely good results with no increase of friction torque.

## 2.4 Compact size

The outside diameter of the HMC-B02 series nut (Photo 1) has been reduced to approximately 70 to 80 percent of the nut used in conventional series by integration of the recirculation circuit into the nut body for a more compact nut. Conversely, higher load capacity and greater rigidity can be achieved by increasing the screw shaft diameter of the HMC-B02 series in the same assembly space of the conventional series.

## 2.5 High sealing performance

Sealing capability is another important property of a ball screw to prevent the intrusion of dust into the nut, and to prevent leakage of lubrication grease from interior of the nut.

Dustproofing of this series is improved by adopting NSK's newly developed screw shaft contact-type seal as the standard seal instead of a conventional labyrinth seal. Test results of our newly developed seal show that foreign matter intrusion was reduced by almost 94 percent in comparison to that of conventional seals. Typical contact seals slide with the screw shaft for higher sealing capability, but at a cost of increased friction torque. Our new seal, however, is very thin, which helps to limit the amount of friction that would normally occur. In addition, a protector is provided to prevent the seal from turning up for enhanced seal durability.

## 2.6. Additional features

Additional features carried over from the conventional series are mentioned here due to their impact on machine tool applications.

One is restraint of temperature rise and thermal displacement. With the progress of higher speeds, heat generated by the ball screw becomes more critical and the displacement of that heat threatens accuracy in the ball screw application. The HMC-B02 series incorporates the same optional cooling system found in our conventional

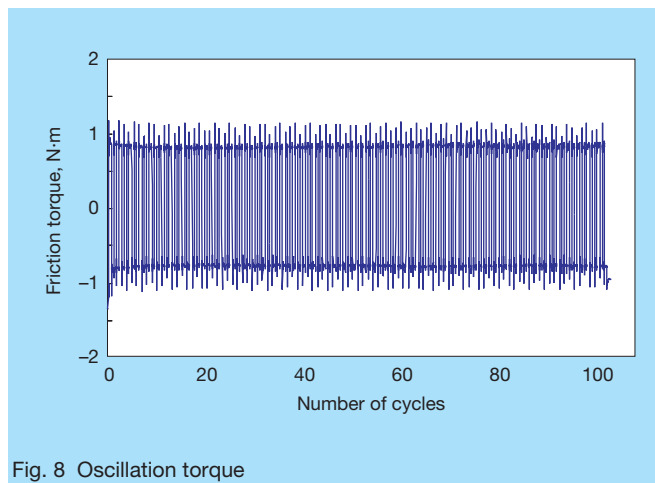

Fig. 8 Oscillation torque

series where forced coolant runs through a hollow shaft.

By using forced coolant, temperature rise and thermal displacement are controlled, and the amount of time required for temperature stabilization is further shortened. Whereas thermal displacement is restrained, the fixed design can be used for both ends of the support bearings of the ball screw shaft. This design ensures higher rigidity of the ball screw system including the support bearings, and makes superior precision positioning and processing possible.

Another feature is larger support bearings, which improves overall rigidity of the ball screw system. Unlike typical ball screws with internal recirculation circuits where the ball screw groove is cut to at least one end of the shaft for easier ball nut assembly, the HMC-B02 series avoids this and retains more wider bearing shoulder at the bearing seat of the shaft and makes it easier to increase the size of the support bearings without the use of a collar for a more rigid support structure.

## 3. Endurance Testing

To realize true high-speed operations, high-speed acceleration and deceleration is indispensable in addition to being able to maintain maximum speed. When driving a large mass, such as in a machining center with high-speed acceleration and deceleration, load to the ball screw is increased and the momentum per each unit of time is increased with higher speeds. Regardless of the fact that such applications normally operate under severe conditions of heavy contamination and debris, permissible levels of precision deterioration become much stricter, and the demand for higher load ratings and durability become more crucial.

Though the HMC-B02 series has a load rating equal to or higher than that of our conventional HMC series, the improvements we made for greater functionality in this series result in much higher durability.

We conducted endurance tests under simulated operating conditions of field-use including environment, using a rated life calculated from dynamic load ratings as



Photo 2 Endurance test equipment

an evaluation reference.

Equipment for endurance testing was designed to simulate operating conditions of an actual machine tool (Photo 2). The ball screw had a 40 mm diameter shaft and a 20 mm lead. The test equipment consisted of a  $1.6 \times 10^3$  kg column placed on a table that was mounted to a ball screw nut. The ball screw was operated at a speed of 3 000 rpm, an acceleration of  $9.8 \text{ m/s}^2$ , and nut stroke of  $230 \text{ mm} \times 3$  steps.

Stroke was divided into three steps to evaluate severe operating conditions by increasing frequency of acceleration and deceleration.

We disassembled and investigated the tested ball screw after testing exceeded the rated life by 1.8 times. Normal rolling traces were observed on the ball grooves of the screw shaft and the nut, with no apparent sign of abnormal wear or damage. Preload was maintained sufficiently throughout testing, and no abnormalities were observed in any of the other components. Testing was started again using the same ball screw and components, and we continued testing in excess of 2.5 times the rated life with no adverse effects.

## 4. Conclusion

NSK's HMC-B02 series of high-speed low-noise ball screws are currently available for commercial applications. With the new developments and improvements we made in this series, such as the recirculation mechanism, NSK provides customers with greatly enhanced performance to meet the demands of the market.

We are confident that customers can take full advantage of the HMC-B02 series for high-speed applications as well, where linear motors tend to be dominant. We hope to apply the concepts and achievements of the HMC-B02 series to other ball screws to meet the needs of all customers.



Masato Kato

# Numerical Analysis Technology & NSK Linear Guides™ for Machine Tools

*Jun Matsumoto*

*Corporate Research & Development Center*

## ABSTRACT

This article introduces the application of numerical analysis technology to the development of NSK Linear Guides™ while focusing on the vital factors of rigidity and running accuracy of machine tools. For this technology, NSK developed a computer program that analyzes the roller guides and takes into account contact characteristics of the rollers and raceways, and their structural deflection. Calculation results of this numerical analysis program agree quite well with experimental results. The level of vibration caused by passage of rolling elements can be estimated quantitatively with our numerical analysis technology, which significantly contributed to the newly developed HA series of NSK Linear Guides™. Experimental results show that the level of ball passage vibration of the HA series is approximately one-third that of conventional products.

## 1. Introduction

In recent years, the demand for rapid product development has been increasing. Products must be developed in a timely manner and at low cost to meet market needs. Under such circumstances, NSK is actively working on the characteristics analysis of products using computers for efficient product development. By making use of characteristics analysis techniques, we have drastically reduced design processes that traditionally repeated the prototyping, testing, and changing of designs.

This article introduces some of NSK's proprietary numerical analysis technologies that are being used to develop linear guides for machine tools, as an example. In the following sections, our numerical analysis technologies will be described focusing on applications for the analysis of rigidity and running accuracy of linear guides for machine tools among many other key characteristics.

## 2. Analysis of Roller Guide Characteristics

### 2.1 Analysis program of roller guide characteristics

Extremely high rigidity and load carrying capacity are required of linear guides for machine tools. To address these requirements, NSK developed a new product called the RA series of NSK roller guides. The RA series is a new type of linear guide that uses rollers as the rolling elements (Fig. 1).

The following points should be taken into account when analyzing the characteristics of the RA series.

- (1) Rollers have a large contact area and are highly rigid. Accordingly, the deformation of individual sliders, rails, and other components should be taken into account in order to accurately calculate the rigidity (displacement characteristics relative to the load) of a roller guide.

- (2) Contact pressure distribution over a roller is usually not uniform. Extremely unbalanced contact pressure distribution due to improper design specifications and operating conditions may cause rolling fatigue and shorten service life. Accordingly, contact pressure distribution should be accurately determined.

These two points are vital for analyzing the characteristics of roller guides. Due to the complexity of the calculations, however, component deformation has hardly been taken into account in conventional rigidity calculations, nor has contact pressure distribution been analyzed in detail.

To achieve optimal roller guide design, NSK developed a program that assesses the characteristics of roller guides in detail (Fig. 2). This program enables more accurate characteristics analysis through simultaneously analyzing both the elastic deformation of and contact pressure distribution on a roller, and the deformation of individual sliders, rails, and other components of a roller guide.

This program uses the well-known Palmgren formula<sup>1)</sup> for calculating the elastic deformation of rollers and the FEM model for calculating the component deformation. Also, a fast and detailed contact pressure analysis method<sup>2)</sup> enables the accurate analysis of contact pressure distribution, while taking local stress concentrations into account.

Examples of analyzing roller guide characteristics with this program are described in the following section.

### 2.2 Applications

#### 2.2.1 Example of rigidity analysis

We measured and calculated displacements relative to various external loads on a roller guide (Fig. 3) for comparison. Calculations are performed in two ways: one with this program and the other assuming the roller guide components to be made of a rigid material. Compared with the measured values, the calculated values assume that

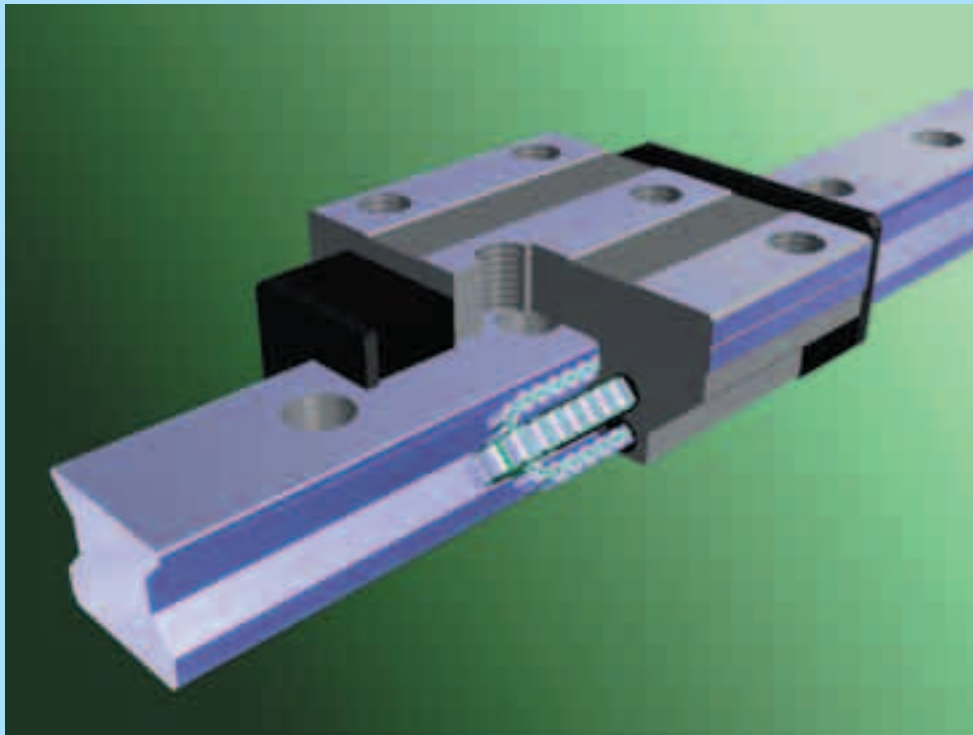

Fig. 1 RA series of NSK roller guides

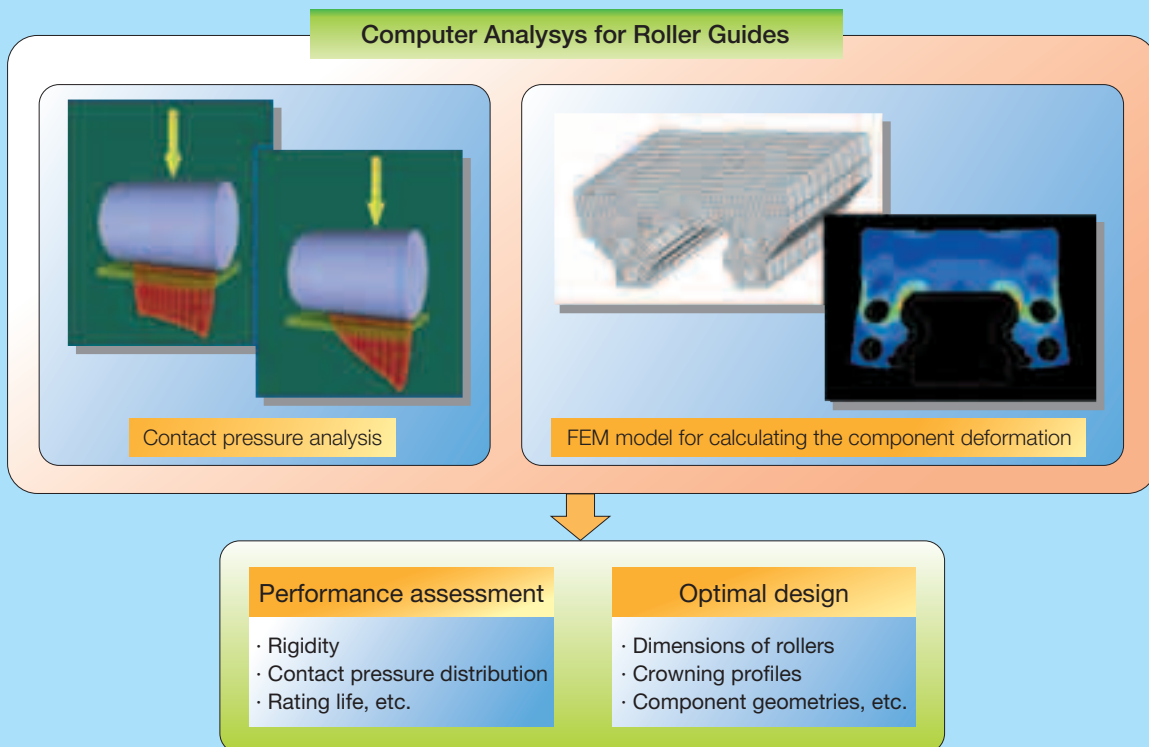

Fig. 2 Calculation method and application of computer analysis for roller guides

the roller guide components, which are made of a rigid material, underestimate the displacement relative to the load, i.e., they overestimate the rigidity. These results indicate that component deformation should be taken into

account to accurately estimate the rigidity of a roller guide.

In contrast, calculated values of the program, which take component deformation into account, agree well with

measured values. It is noteworthy that differences in rigidity for compression and tension are well simulated.

The measured and calculated displacements of several roller guides with different preloads under external loads of 4 000 N and 10 000 N were compared (Fig. 4). The calculated values agree well with the measured values in both compression and tension directions.

As seen from the above examples, the program enables accurate calculation of the rigidity of roller guides, which was mostly ignored in the past.

### 2.2.2 Examples of analyzing contact pressure distribution

One of the key issues in roller guide design is the crowning shape of the rolling element. Crowning is the gently slanted curve near the roller edges, for which contact pressure distributions are calculated for rollers with various crowning profiles (Fig. 5). Contact pressure distribution is asymmetrical due to a tilt of the raceway caused by slider deformation. On a roller without crowning (Fig. 5-A), stress is concentrated on both edges. These outstanding contact pressures concentrated on roller edges, called edge loads, are undesirable because they may

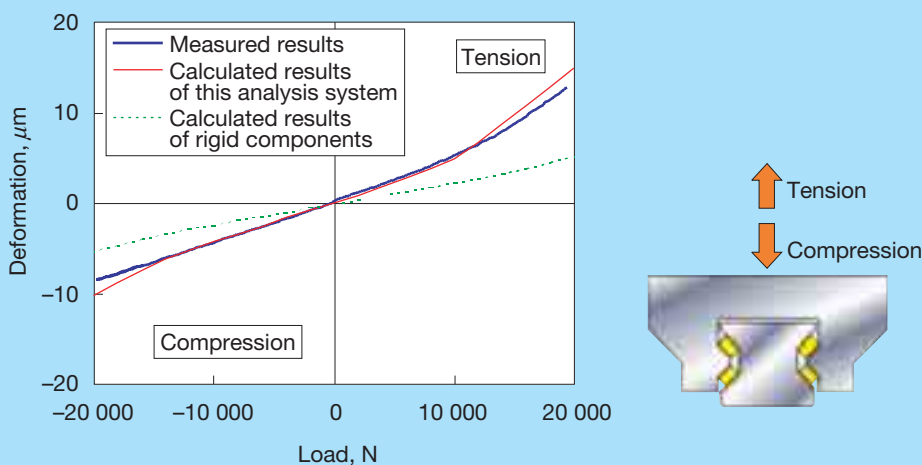

Fig. 3 Deformation of roller guide (Model size #35, preloaded)

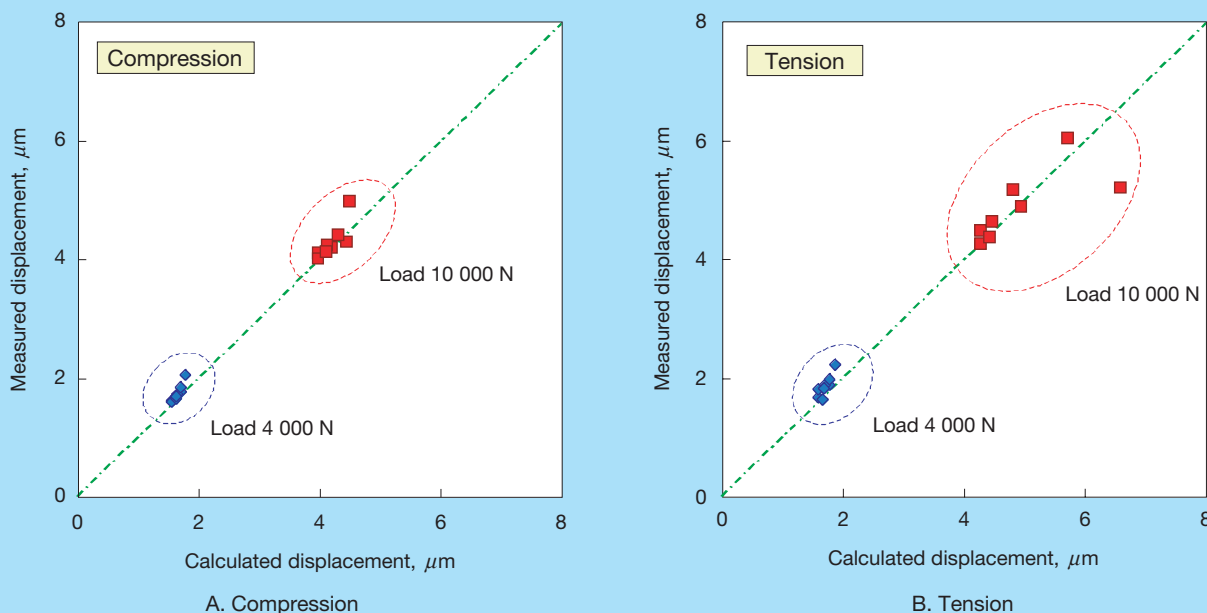

Fig. 4 Actual and calculated rigidity of roller guides (Model size #35, medium-to-heavy preload)

reduce the service life of linear guides.

Partial crowning (Fig. 5-B) or full crowning (Fig. 5-C) can prevent edge loads. Overly long crowning, such as in full crowning, shortens the length of contact with the raceway and will reduce the rigidity of the roller guide. Through detailed analytical studies of these issues, NSK has established the optimum crowning shape for roller guides.

We calculated the values of contact pressure distribution on each roller in the roller guide (Fig. 6). Such calculations were made assuming two cases: only preload is applied or preload with 15 000 N compressive load is applied to the slider. Results indicated that the contact pressure on each roller could be assessed in detail with this program. Such detailed calculation of contact pressure distribution is vital for accurately assessing the service life of roller guides under different load conditions in actual use.

### 2.2.3 Optimal design with the analysis system

In designing the roller guides, we actively used this program to fully study and optimize component geometry. For example, the slider component shape was determined by using this analysis system in order to maximize its rigidity. We compared the measured rigidities of an NSK roller guide and those of an existing roller guide manufactured by a competing company (Fig. 7). The NSK roller guide, which was optimized through characteristics analysis, achieves higher rigidity than that of the competing roller guide.

As described above, characteristics analysis system for roller guides can be efficiently used in developing sophisticated products.

## 3. Running Accuracy Analysis for Linear Guides

### 3.1 Analysis of vibration generation in linear guides

The running accuracy of a linear guide is vital for machine tools to improve machining accuracy and upgrade machined surfaces. NSK has also been working on numerical analysis of the running accuracy of linear guides in order to develop a linear guide that can run with high accuracy<sup>3)</sup>.

The vibrations caused by the passage of rolling elements are well known as one key factor that adversely affects the running accuracy of linear guides. We measured the posture changes (angular changes in the pitching direction) in a linear guide with an autocollimator as the slider moved at a constant speed (Fig. 8). Cyclic vibration with a wavelength approximately twice the diameter  $D_w$  of the rolling element was observed. This vibration is related to the movement of rolling elements inside the linear guide, which NSK refers to as ball passage vibration. Vibration also occurs in the translational direction, in addition to the angular changes shown here.

Ball passage vibration in an actual machine might be as small as  $1\ \mu\text{m}$  or less, but it causes cyclic fluctuation that may lead to the degradation of machined surfaces. Accordingly, reducing ball passage vibration is extremely important for linear guides used in machine tools.

NSK has succeeded in clarifying the mechanism of ball passage vibration and has established a quantitative analysis method as illustrated in the diagram below (Fig.

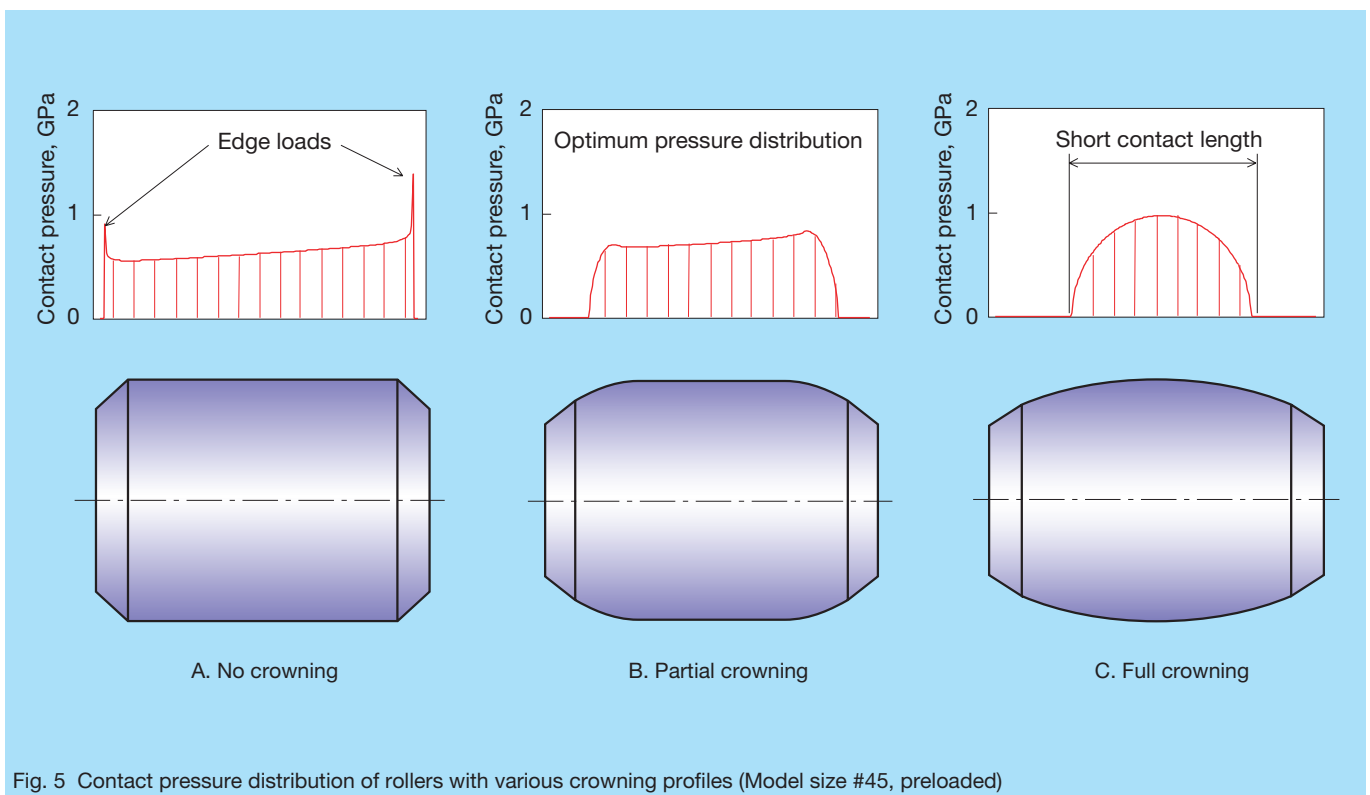

Fig. 5 Contact pressure distribution of rollers with various crowning profiles (Model size #45, preloaded)

9), which also shows calculated ball passage vibration. The mechanism of ball passage vibration is briefly described here.

The arrangement of balls inside a slider changes as the slider moves. Usually, preload is applied to the balls and load distribution on the balls changes as they move. This change in load distribution changes the slider posture. As a result, ball passage vibration occurs.

Fig. 9 illustrates the arrangements of balls inside the slider, as well as the load distribution on the balls, at points A and B in the diagram. To balance the internal load, the slider tilts clockwise at position A (left figures) and counterclockwise at position B (right figures). Thus, the slider constantly changes in posture as it moves in the longitudinal direction. In addition to the above displacement in the pitching direction, displacements of the slider also occur in the vertical, horizontal, rolling, and yawing directions.

Ball passage vibration can be calculated using equations considering both external and internal loads on a linear guide. We compared the results of measured and

calculated values of ball passage vibration of several linear guides of different sizes (Fig. 10, A). The calculated values matched well with the measured values, which confirms the effectiveness of our analysis.

A similar calculation method is applicable to calculating ball passage vibration in a table built with a combination of multiple linear guides. We compared the results of calculated and measured values of ball passage vibration in several tables composed of two rails and four sliders using linear guides of different sizes (Fig. 10, B). The calculated values again agree well with the measured values.

As described above, NSK has succeeded in quantitatively analyzing ball passage vibration.

### 3.2 Application of running accuracy analysis to product development

The above analysis method was used to establish design guidelines for reducing ball passage vibration. We compared the calculated values of ball passage vibrations with a varying number of balls that were loaded in each

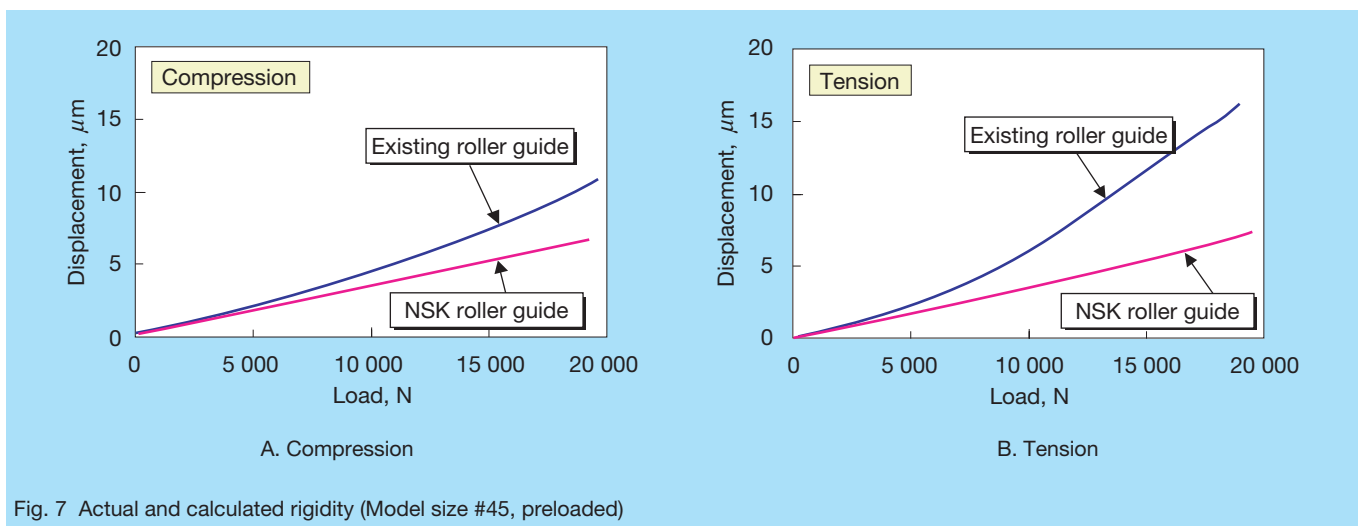
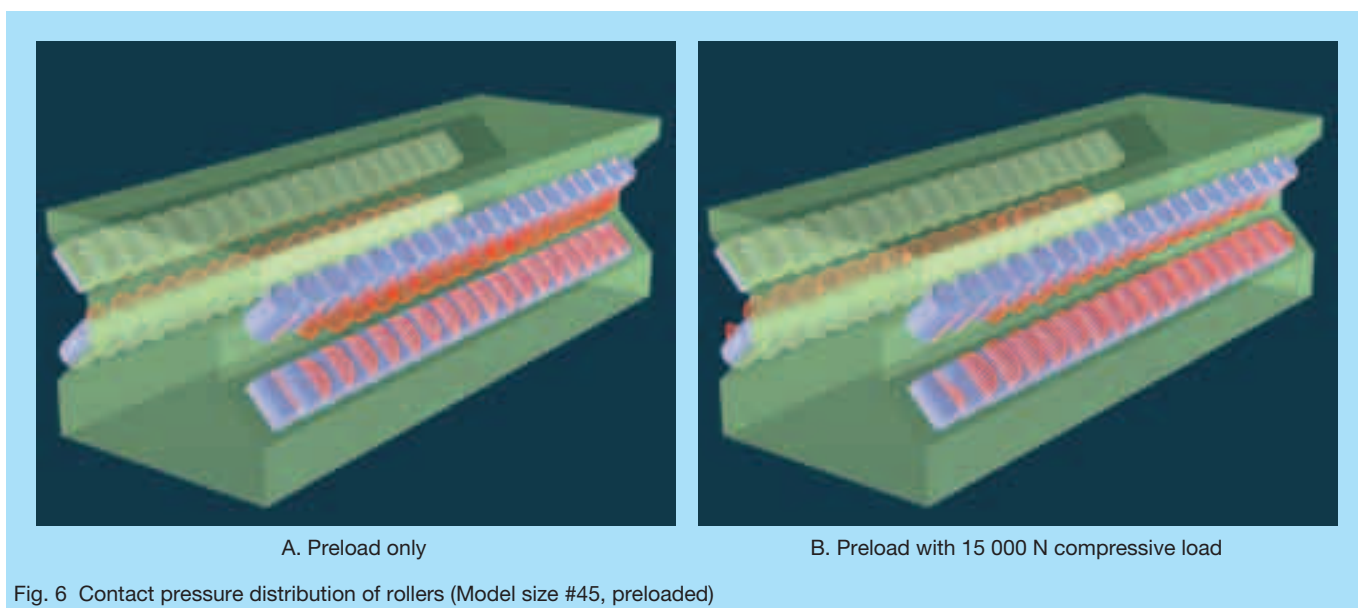

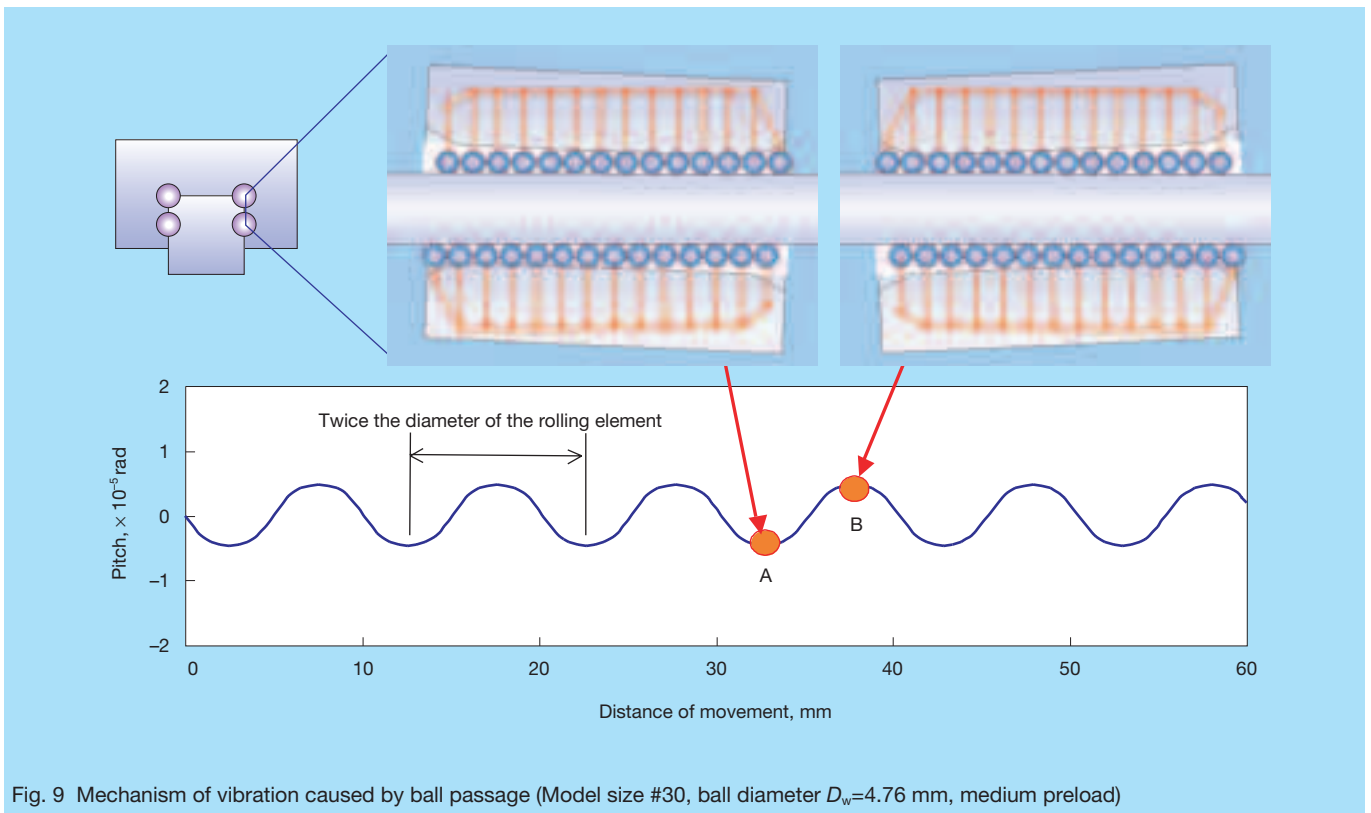
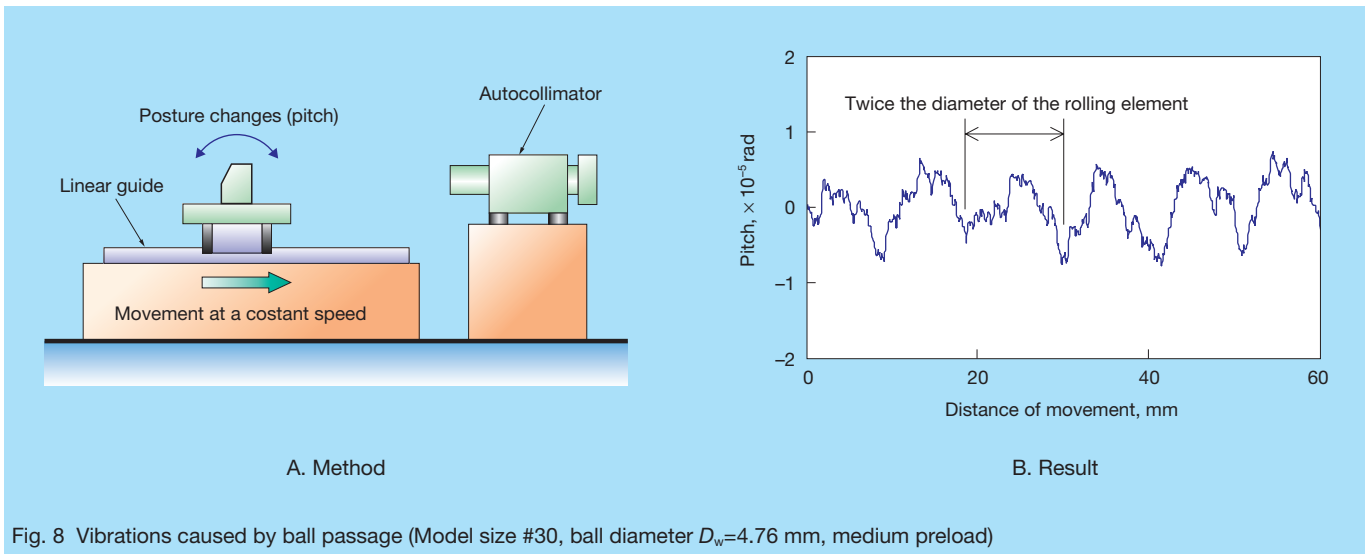

groove (effective number of balls) assuming that the elastic deformation of each ball under the preload was constant (Fig. 11). As the effective number of balls increased, ball passage vibration decreased. When the effective number of balls exceeded a certain limit, however, vibration was not efficiently reduced. Increasing the effective number of balls requires a longer slider and prevents the size reduction of the unit. The effective number of balls suitable for this example is approximately 30.

Raceways in the slider have a gently slanted curve near both ends of the groove. This slanted portion is called crowning. The crowning shape is another key design issue

affecting the magnitude of ball passage vibration.

We compared the calculated values of ball passage vibration caused by conventional crowning and NSK's developed crowning (Fig. 11). Results show that NSK's unique crowning design effectively suppresses ball passage vibration.

Using the results discussed above, NSK moved forward and developed the HA series of NSK Linear Guides™ (Fig. 12). The HA series is based on the LA series, which has six grooves, and currently enjoys proven success in machine tool applications. In the HA series linear guide, assorted design specifications have been adopted to

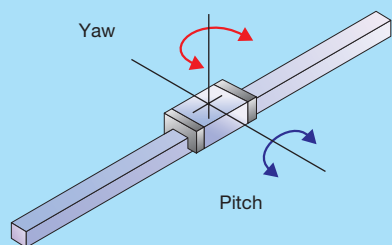
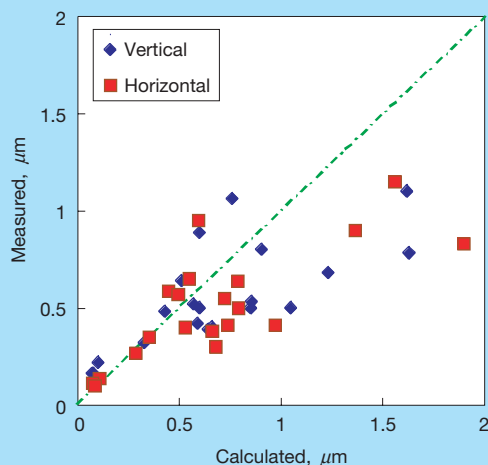
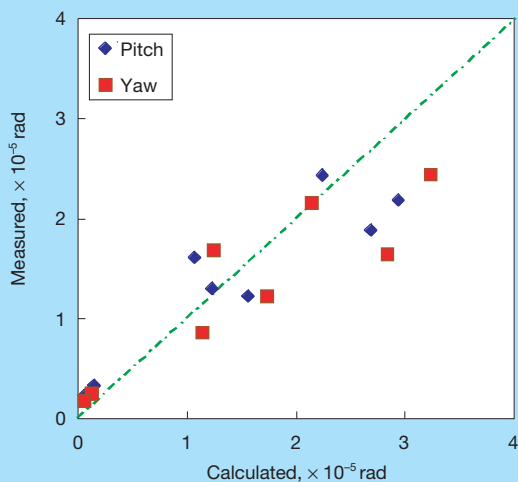

A. Linear guide (single rail)

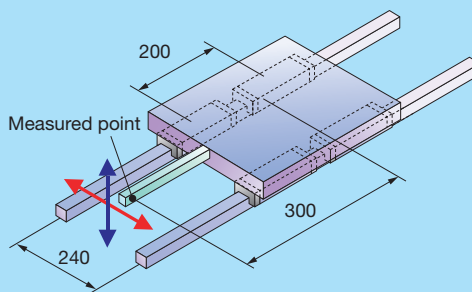

B. Table unit

Fig. 10 Actual and calculated vibrations caused by ball passage (Model size #25 to #45, ball diameter  $D_w=3.97$  mm to 7.94 mm)

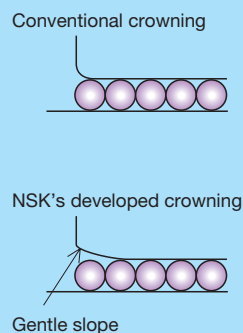
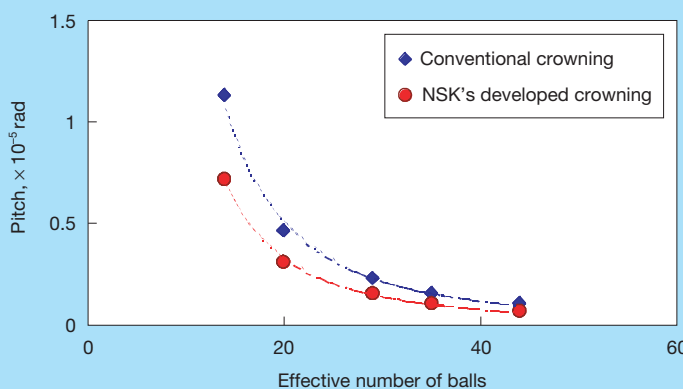

Fig. 11 Effective number of balls and calculated ball passage vibrations (Ball diameter  $D_w=4.76$  mm, medium preload)

improve running accuracy, in addition to measures to reduce ball passage vibration and specially designed bolt holes for minimizing deflection of the rail caused by tightening bolts.

We made a comparison of the measured values of ball passage vibration of actual HA and LA series tables composed of multiple linear guides (Fig. 13). For this

measurement, we had to equal the amount of rigidity of the tables by using eight sliders of the LA series and four sliders of the HA series. Both tables have the same outer dimensions. Displacement components due to the profile accuracy of the base components and other factors have been removed in order to show only the measured values of ball passage vibration.

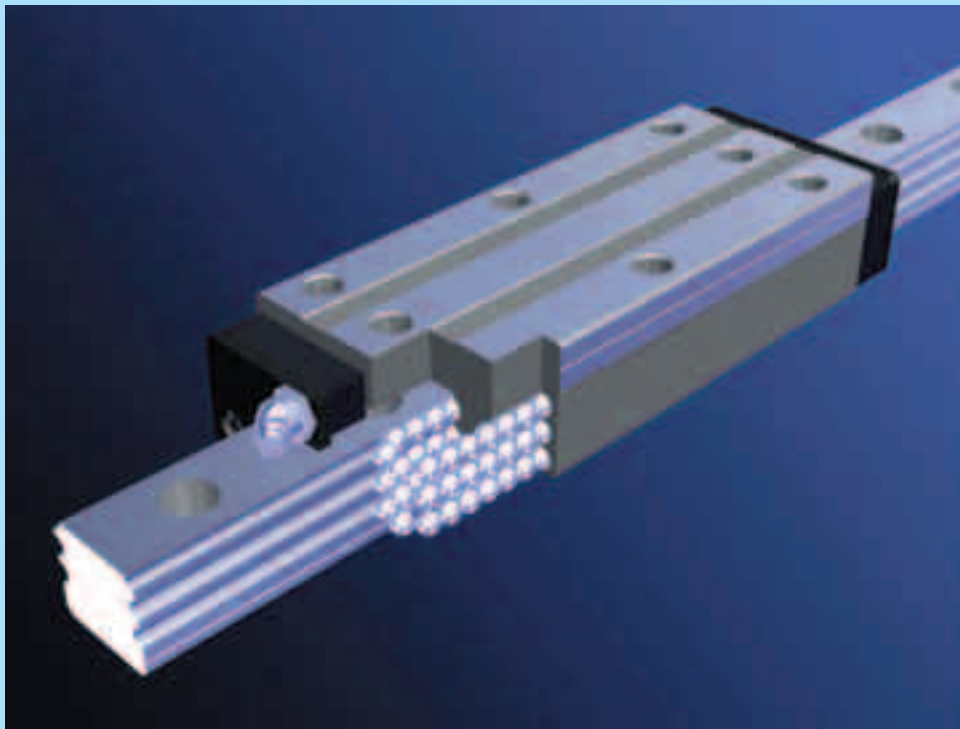

Fig. 12 NSK HA series of linear guides

We can see that ball passage vibration of the HA series linear guide has been reduced to approximately one-third that of conventional guides (Fig. 13). This demonstrates that the HA series linear guide provides higher running accuracy while preserving the same table dimensions and rigidity as conventional guides.

HA series linear guides are enjoying great popularity and being used in high-precision machining equipment in which high machining precision and high-grade machined surfaces are vital, as well as for precision tables, which have traditionally used air sliders. As described above, NSK has efficiently achieved an optimal design by using knowledge obtained through analysis of running accuracy.

#### 4. Conclusion

This article briefly introduced some of our analysis technologies with a focus on linear guides for machine tools. NSK has been conducting characteristics analysis for all of our products, in addition to the products described in this article. We look forward to using our analysis results in furthering the development of new and better products.

We will further upgrade our analysis technologies and provide more sophisticated products anticipating future market needs.

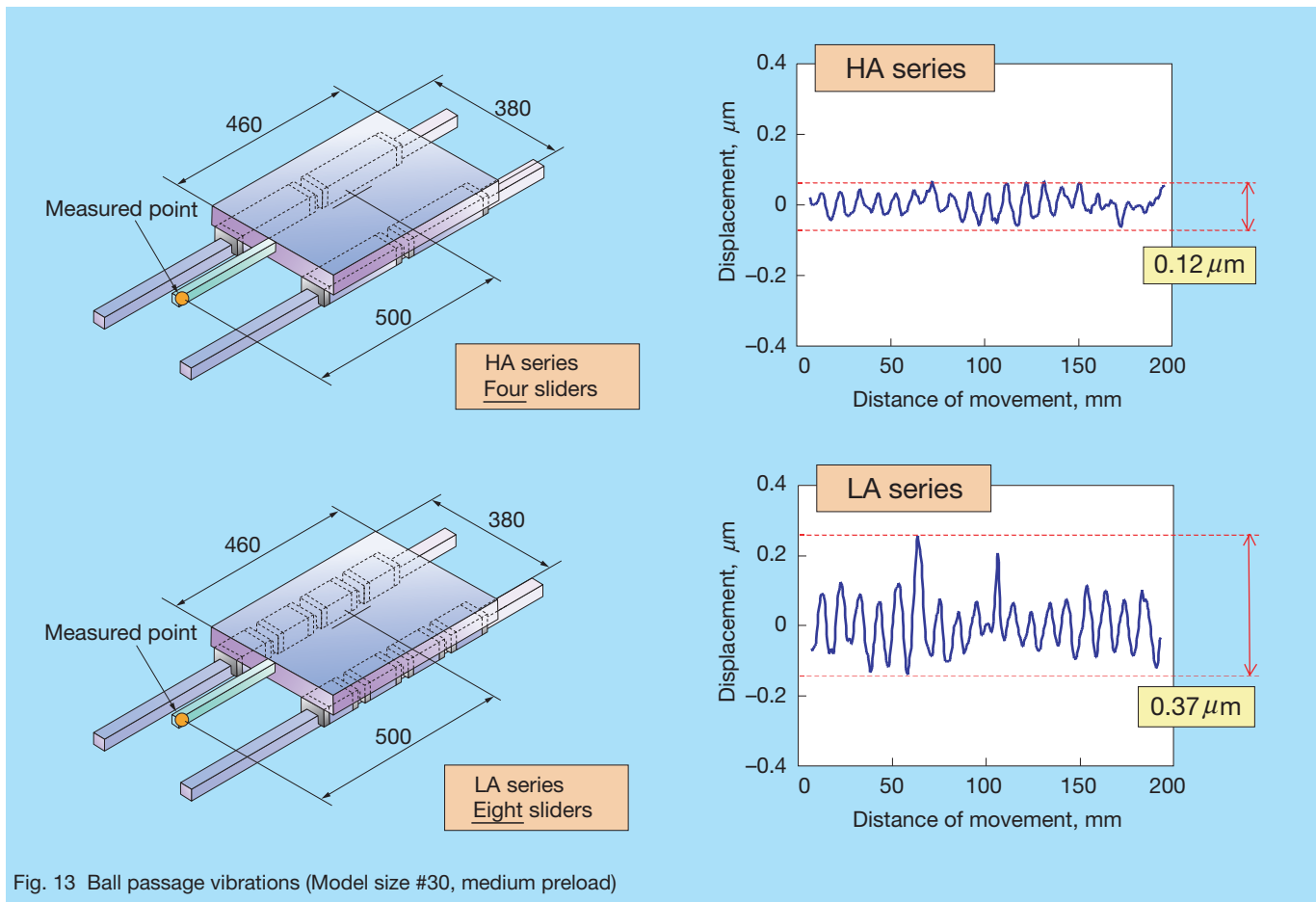

Fig. 13 Ball passage vibrations (Model size #30, medium preload)

**References:**

- 1) E. Watabayashi, "Rolling Bearing Manual" (1999) 151-155  
Japanese Standard Association
- 2) S. Natsumeda, "Application of MLMI to Contact Problems in Rolling Bearings"  
NSK Technical Journal, No.666, (1999) 29-37
- 3) S. Kato, J. Matsumoto, "Recent Developments in Highly Precise NSK Linear Guides"  
NSK Technical Journal, No.669, (2000) 42-49



*Jun Matsumoto*

# High-Speed Precision Angular Contact Ball Bearings—Spinshot™ II

High-speed bearings can be found in a variety of applications including jet engine bearings and machine tool spindle bearings. In machine tool spindle bearings, some of the more critical properties required are high rigidity, high-speed reliability, and low temperature rise.

In integral motorized spindle applications, bearings that are highly resistant to temperature fluctuations are in high demand. NSK has responded to such demand by developing and marketing its ROBUST series of ultra high-speed angular contact ball bearings for machine tool spindles. Up until now, users requiring ultra-high-speed rotation capabilities have had no choice but to adopt jet lubrication or under-race jet lubrication for their applications. However, there is a trade-off for the gains made in higher speed capability. Jet lubrication requires bulky lubrication equipment, consumes large amounts of oil, and due to churning, power consumption is high; thus requiring use of a high-output motor.

NSK's successful development and commercialization of the ROBUST series Spinshot™ II bearings, which use an oil-air lubrication system, provide customers with higher speeds, quieter operations, and less demand for

compressed air. Details of NSK's Spinshot™ II bearings are provided in this article.

## 1. Bearing Structure

Typically, high-speed operations of bearings in an ultra high-speed motor spindle are hampered by limitations of the lubrication system. In conventional lubrications systems, high-speed operations create an air curtain, which prevents conventional oil-air lubrication systems (Fig. 1) from injecting oil precisely into the bearing interior. This condition hinders proper lubrication, which ultimately results in bearing seizure.

NSK's ROBUST series Spinshot™ II bearings are designed with an inner ring that is tapered on the front face side and extends beyond the width of the outer ring (Fig. 1). Lubrication oil, with the assistance of compressed air, is sprayed from the outer ring spacer to the outside surface of the inner ring (Fig. 2). The Spinshot™ II system employs a combination of centrifugal force, airflow, and surface tension to direct oil flow into the bearing interior as bearing speed increases.

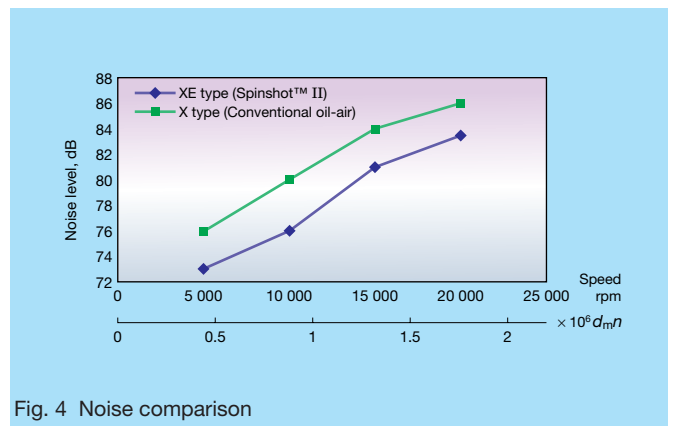
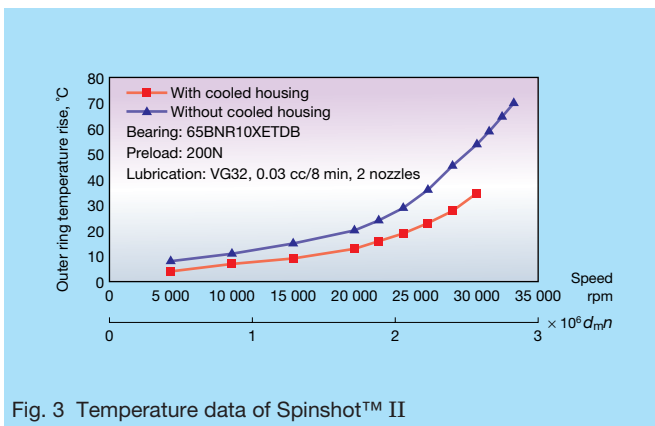
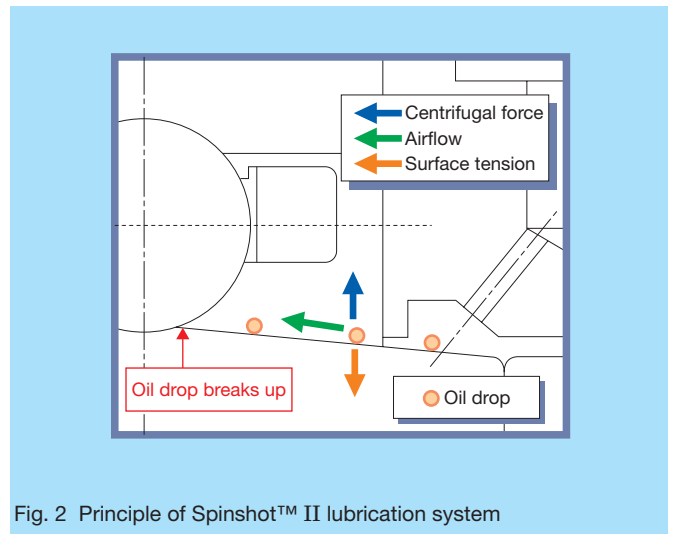
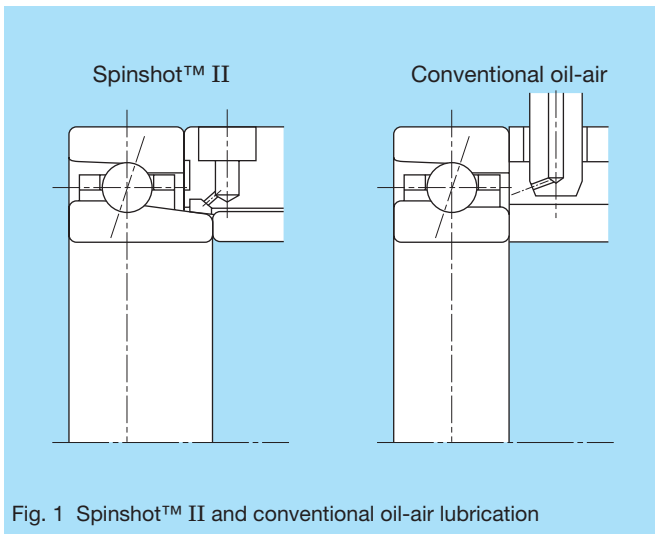

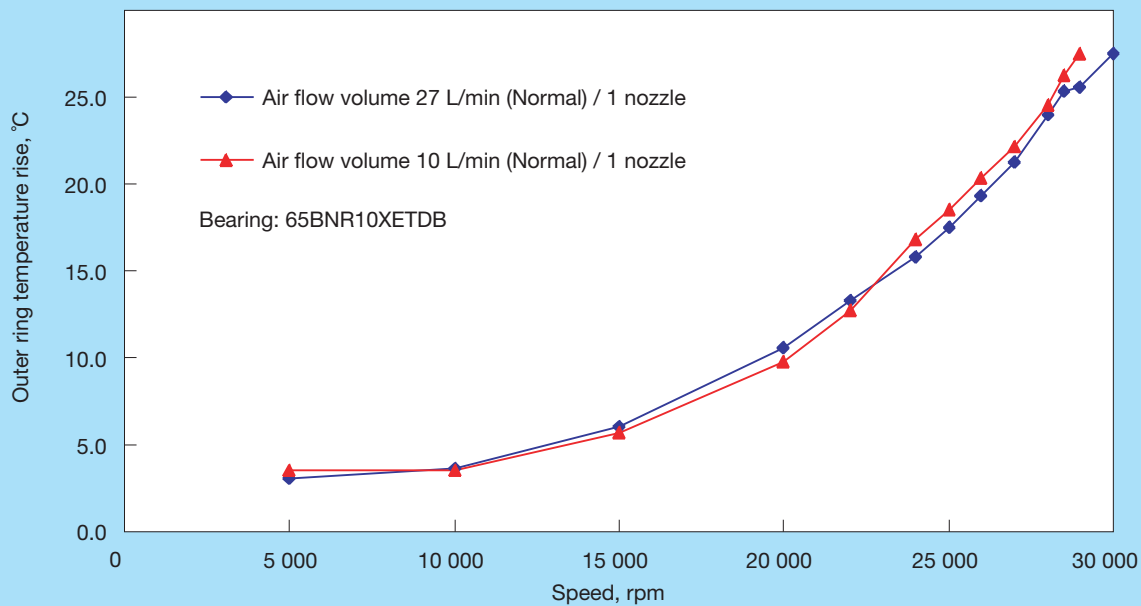

Fig. 5 Temperature rise & Compressed air requirements

## 2. Features

### 2.1 High speed

NSK's ROBUST series Spinshot™ II bearings achieve high-speed operations by incorporating two primary proprietary technologies. The Spinshot™ II lubrication system works to control temperature rise for greater stability at high operating speeds by ensuring adequate lubrication to the balls for improved reliability. Bearing tests using the Spinshot™ II system under conditions of position preload and cooled housing (Fig. 3) achieved a limiting speed of  $2.5 \times 10^6 d_m n$ . High-speed reliability is further achieved by incorporating NSK's ROBUST series design. ROBUST bearings further ensure durability at high speeds by using a special bearing structure that includes ceramic balls, and SHX steel for the inner and outer rings.

### 2.2 Low noise

The ROBUST series Spinshot™ II bearings provide machine tool spindle operators with a much quieter working environment. By using the Spinshot™ II lubrication system, the flow of air is redirected in such a way to eliminate the more direct approach found in conventional systems (Fig. 1). The result is a much quieter working environment that is free of the typically harsh high-pitched noise found in conventional oil-air lubrication systems running at high-speeds (Fig. 4).

### 2.3 Excellent cost performance

Excellent cost performance of the ROBUST series Spinshot™ II bearings is achieved by reducing the required amount of compressed air by 60 % in comparison to that of conventional oil-air lubrication systems. Conventional oil-air lubrication systems require higher air pressure at high-speeds because an air curtain, which is naturally formed at high-speed rotation, disrupts the oil

supply. This condition made it difficult to reduce compressed air requirements.

The Spinshot™ II system directs the flow of lubrication oil along the inner ring to ensure a reliable supply of lubricant directly to the bearing interior. This unique system reduces the amount of compressed air required to ensure a steady flow of lubricant to the bearing interior to as little as 10 L/min (Normal) per nozzle. Furthermore, temperature rise at high speeds is almost the same as that found in conventional oil-air lubrication systems (Fig. 5). Users can thus be assured of stable performance while enjoying the benefits of reduced operational costs.

## 3. Applications

NSK's ROBUST series Spinshot™ II bearings are best suited for high-speed machine tool spindles used in high-speed machining centers and high-precision milling spindles in multi-task machines. Using our ultra high-speed ROBUST series cylindrical roller bearings, users can further achieve a simplified main shaft structure with high rigidity that can be operated at ultra-high speeds.

## 4. Summary

Machine tool spindle bearings using conventional oil-air lubrications systems have limited high-speed applications. NSK's ROBUST series Spinshot™ II bearings make it possible to achieve ultra high-speed operations with low temperature rise, less noise for a quieter working environment, and excellent cost performance. The superior high-speed performance of these bearings and lubrication system are the perfect match for high-speed machining applications. From a standpoint of performance and cost benefit, we are confident that NSK's ROBUST series Spinshot™ II bearings will prove to be indispensable for machine tool makers and end users alike.

# Super Precision Sealed Angular Contact Ball Bearings

Environmentally friendly and clean technologies for machine tool spindle bearings have attracted considerable attention throughout the machine tool industry. This has created strong demand for sealed bearings that are prepacked with grease. NSK has responded to such market needs with newly developed super precision sealed angular contact ball bearings (Photo 1) for both the NSK Standard series and the NSK ultra high-speed ROBUST series.

## 1. Features

### 1.1 Improved workability

Prepacked bearings eliminate the need to pack grease into the bearing when assembling the main spindle.

### 1.2 Environmentally friendly

Seals keep the grease inside and prevent leakage (Fig. 1).

### 1.3 Flexible arrangement

Standard stock of interchangeable universal arrangement (SU) bearings.

### 1.4 High speed

High-speed operations are achieved through the use of a non-contact seal (Fig. 2) that has been manufactured using nitrile rubber. This material was chosen for its superior oil and wear-resistant qualities, and its superior mechanical properties.

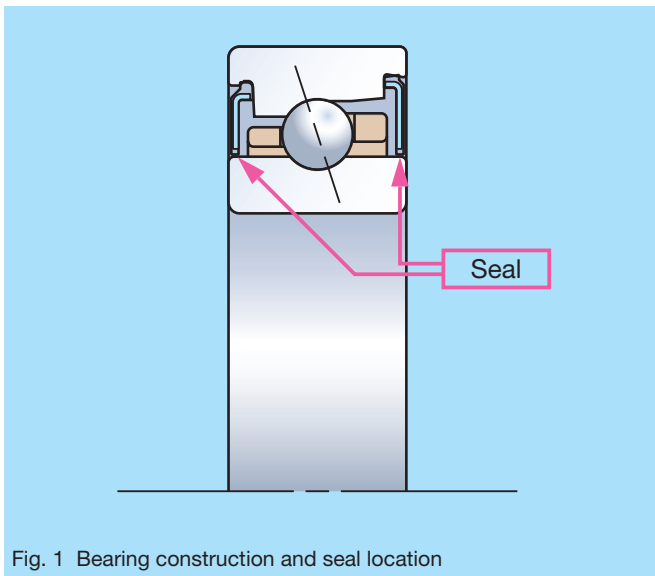

Fig. 1 Bearing construction and seal location



Photo 1 Super precision sealed angular contact ball bearings

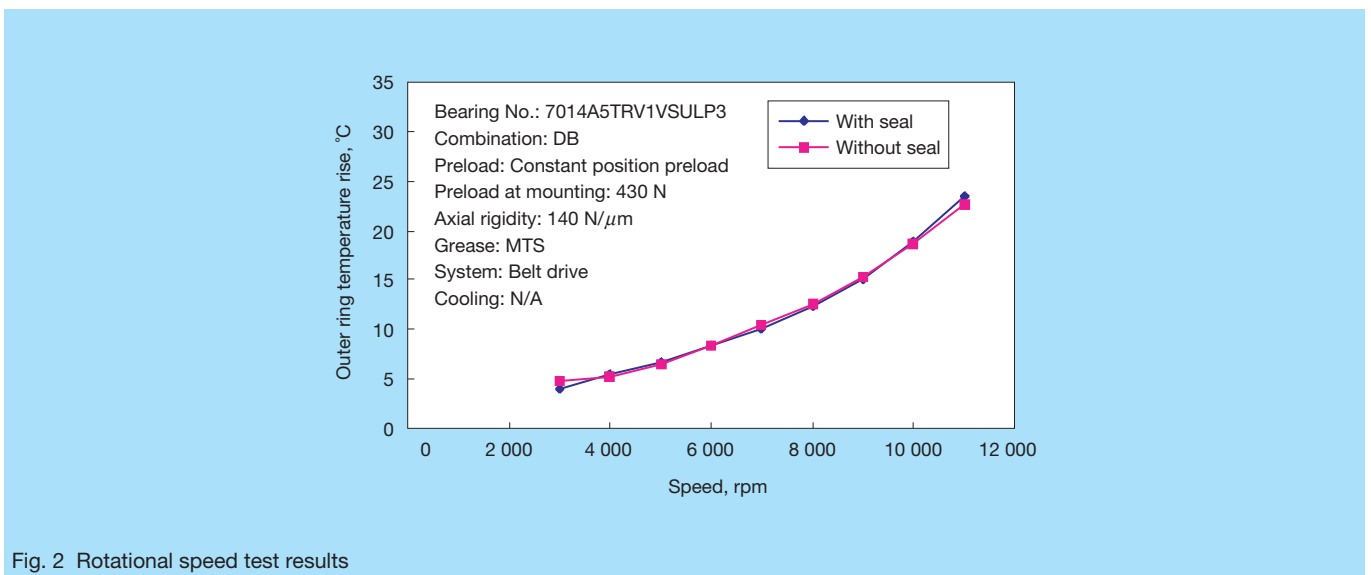

Fig. 2 Rotational speed test results

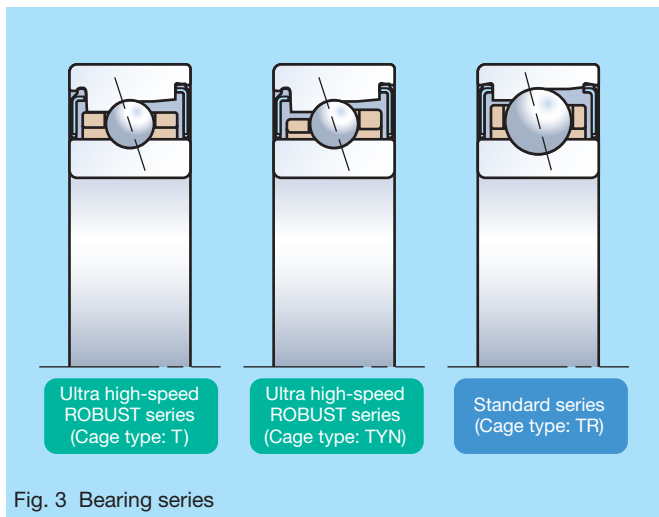

Fig. 3 Bearing series

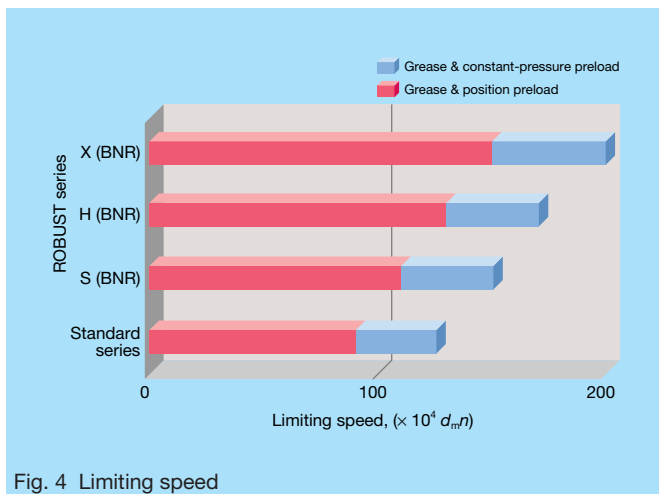

Fig. 4 Limiting speed

## 2. Specifications

### 2.1 Different cages are available to best meet the needs of user applications (Fig. 3).

- Outer-ring-guided cage: Outer-ring-guided phenolic resin cage provides superior high-speed stability. Two types of cages are available: The T cage is designed for the ROBUST series, and the TR cage is designed for the Standard series.
- Ball-guided cage: NSK's original ball-guided polyamide resin cage (TYN) reduces cage noise, reduces bearing wear at low-speed operations, and improves grease life. The TYN cage is designed for H and S types of ROBUST series bearings.

### 2.2 Dimensions

Standard boundary dimensions are available (Table 1). Please contact NSK for other dimensions.

### 2.3 Limiting speed

A wide range of limiting speed is available to meet the needs of various applications (Fig. 4).

Table 1 Boundary dimensions

Series	Dimension series	Contact angle (°)	Bearing bore
ROBUST series	BNR10, BNR19	18	φ30–φ100*
	BER10, BER19	25	
Standard series	70××C, 79××C	15	
	70××A5, 79××A5	25	

\*Contact NSK for availability of other sizes.

### Type code

ROBUST series	Type	Material	
		Inner and outer rings	Rolling element
ROBUST series	X	High-speed, heat-resistant steel (SHX)	Ceramic (Si <sub>3</sub> N <sub>4</sub> )
	H	Bearing steel (SUJ2)	Ceramic (Si <sub>3</sub> N <sub>4</sub> )
	S	Bearing steel (SUJ2)	Bearing steel (SUJ2)
Standard series		Bearing steel (SUJ2)	Bearing steel (SUJ2)

## 3. Applications

NSK's super precision sealed angular contact ball bearings are primarily optimized for superior performance in machining centers and lathes.

## 4. Summary

NSK has responded to the needs of our customers with the development and marketing of super precision sealed angular contact ball bearings for NSK's ROBUST series and Standard series. We will continue to work on newer developments to meet the future needs of our customers.

# Sealed Angular Contact Thrust Ball Bearings for Ball Screw Supports

Usually the angular contact thrust ball bearings provide support to the shaft end of a ball screw where they are mounted in the support units and equipped with oil seals. When used in machine tool applications, the high accuracy and rigidity of these bearings become critical factors in ensuring superior machine tool performance. These bearings provide added value for machine tool applications by preventing the intrusion of cutting oil or metal chips into the bearing by incorporating seals on both sides of the bearing (Fig. 1). Recent trends toward smaller and more compact machine tools require that ball screw support units also respond with even greater compactness. NSK has responded with the development of our TAC series of sealed angular contact thrust ball bearings for ball screw supports.

## 1. Features

### 1.1 Contact seals

From among the types of seals currently in use, we chose a low-torque seal with minimal contact in consideration of the high-speed requirements of machine tool applications. To ensure sealing performance, we adopted the DDG labyrinth seal (Table 1), which is positioned between the seal lip and seal groove of the inner ring. The DDG seal has an excellent performance record in bearings used for engine accessories and related automotive components. By inserting contact seals in both ends of the bearing, intrusion of foreign matter is prevented. An additional

benefit is that grease leakage is restrained, which helps ensure a clean and safe working environment. The seals are also color-coded to ensure mounting in the proper direction, which has proven to be an effective means of preventing mounting errors in the field.

### 1.2 WPH grease

NSK adopted WPH lubricating grease for these bearings for a variety of reasons. This grease has proven itself to be a highly effective lubricant in automotive water pump bearings where performance demands are even greater than those of machine tool applications. WPH grease consists of polyalphaolefin (PAO) base oil for superior oxidation stability, and urea compound, which provides superior heat and water resistance, acts as a thickener, and includes additives for ensuring high quality performance. Additional features of WPH grease include:

- A. Maintains firmness in harsh environments to prevent grease outflow and to prevent ingress of coolant, which achieves extended lubricating performance and prevents bearing flaking.
- B. High-temperature durability prevents deterioration and bearing seizure under extreme temperature-rise conditions.
- C. Excellent rust prevention ensured even if water or coolant enters the bearing.

### 1.3 Interchangeable with TAC series

NSK's new sealed angular contact thrust ball bearings for ball screw supports have the same boundary dimensions (bore diameter, outside diameter, and width) and load rating as the current TAC series. Customers can easily replace their current bearings with this product without having to make any changes to the shaft or housing. As this bearing uses a universal combination, which is standard for this series, and maintains tolerance of the bore and the outside diameter stricter, customers can make any combination using this bearing.

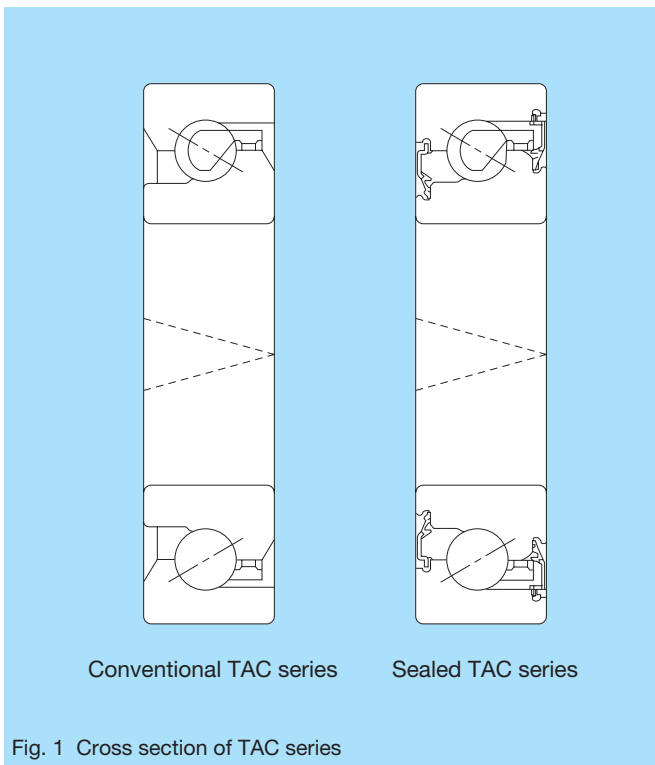
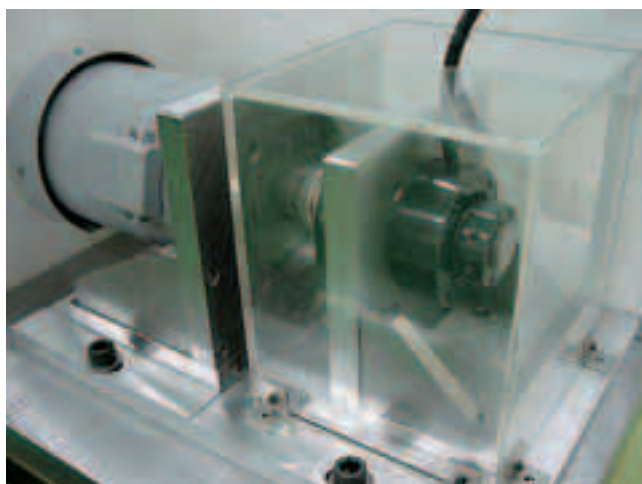
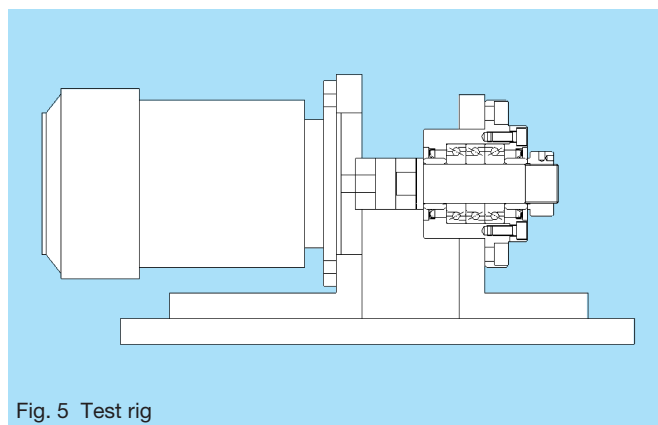
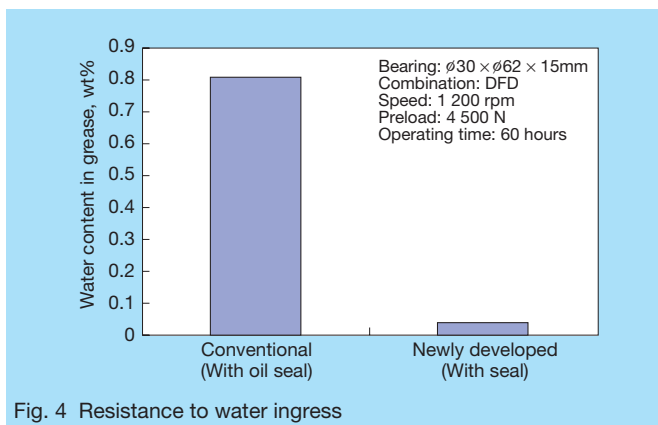
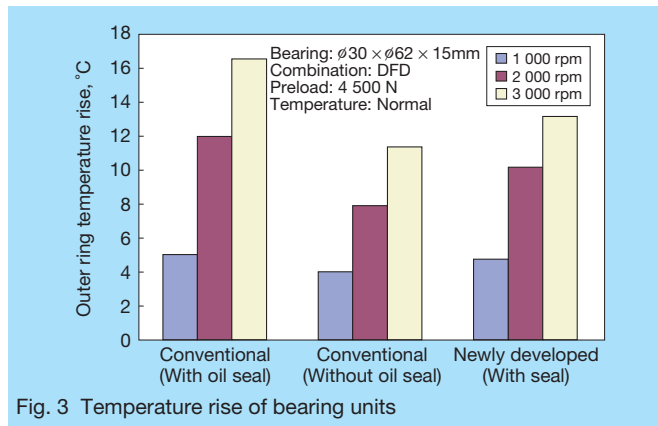
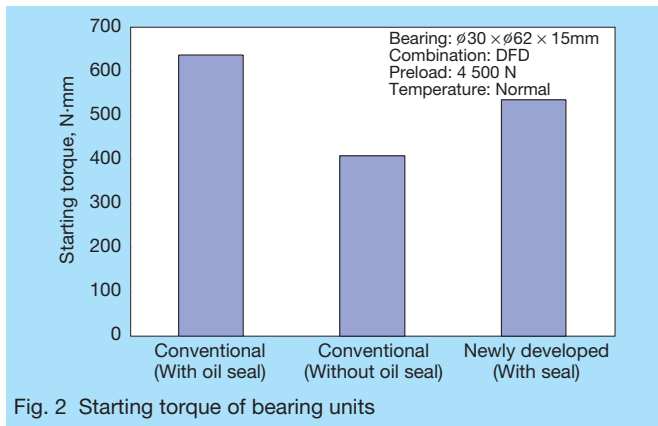

Table 1 Seal type and performance

Seal type	Conventional		Newly developed
	DDU	DDW	DDG
Seal structure			
Torque	Not as good	Superior	Superior
Water proof	Good	Good	Superior
Grease sealing capability	Good	Superior	Superior



## 2. Performance

Comparisons of starting torque, temperature rise, and waterproofing of the sealed angular contact thrust ball bearings for ball screw supports are shown in Fig. 2, 3, and 4. A drawing and a photo of the test rig used for evaluating performance are also provided (Fig. 5 and Photo 1). These evaluations show that the performance of NSK's newly developed sealed angular contact thrust ball bearings for ball screw supports are superior to the current units with oil seals.

## 3. Application

Sealed angular contact thrust ball bearings for ball screw supports provide optimum performance for ball screw supports of machine tools operating under harsh environments where exposure to cutting oil and metal chips present a potential threat to conventional bearings.

## 4. Summary

Our sealed angular contact thrust ball bearings for ball screw supports are available in standard dimensions and compact sizes for complete interchangeability with superior bearing performance to better meet the needs of our customers and end users alike.

# High-Performance Cylindrical Roller Bearings

## —Double Row Cylindrical Roller Bearings & Ultra High-Speed Single Row Cylindrical Roller Bearings

NSK has developed and marketed a new type of High Rigidity series of double row cylindrical roller bearings and a new type of ROBUST series of ultra high-speed single row cylindrical roller bearings. These cylindrical roller bearings were designed to provide customers high-performance functionality with a special focus on high rigidity and high-speed operations for main shaft spindles.

incorporating machining center functions into their designs. With the new functions of these complex machines come higher speed capability requirements. In fact, the maximum rotating speed of main shaft spindles with grease lubrication have risen to as much as  $8 \times 10^5 d_m n$ . As is the case with any main shaft spindle, increased speeds equate to an increase in temperature rise of the bearings and motor, thermal displacement of the shaft, and the resulting problems of diminished processing accuracy. NSK has successfully solved these problems with a newly developed High Rigidity series of double row cylindrical roller bearings. These bearings were developed with NSK's proprietary technologies resulting in a product

### 1. High Rigidity Series of Double Row Cylindrical Roller Bearings

#### 1.1 Background

An increasing number of recent models of lathes are

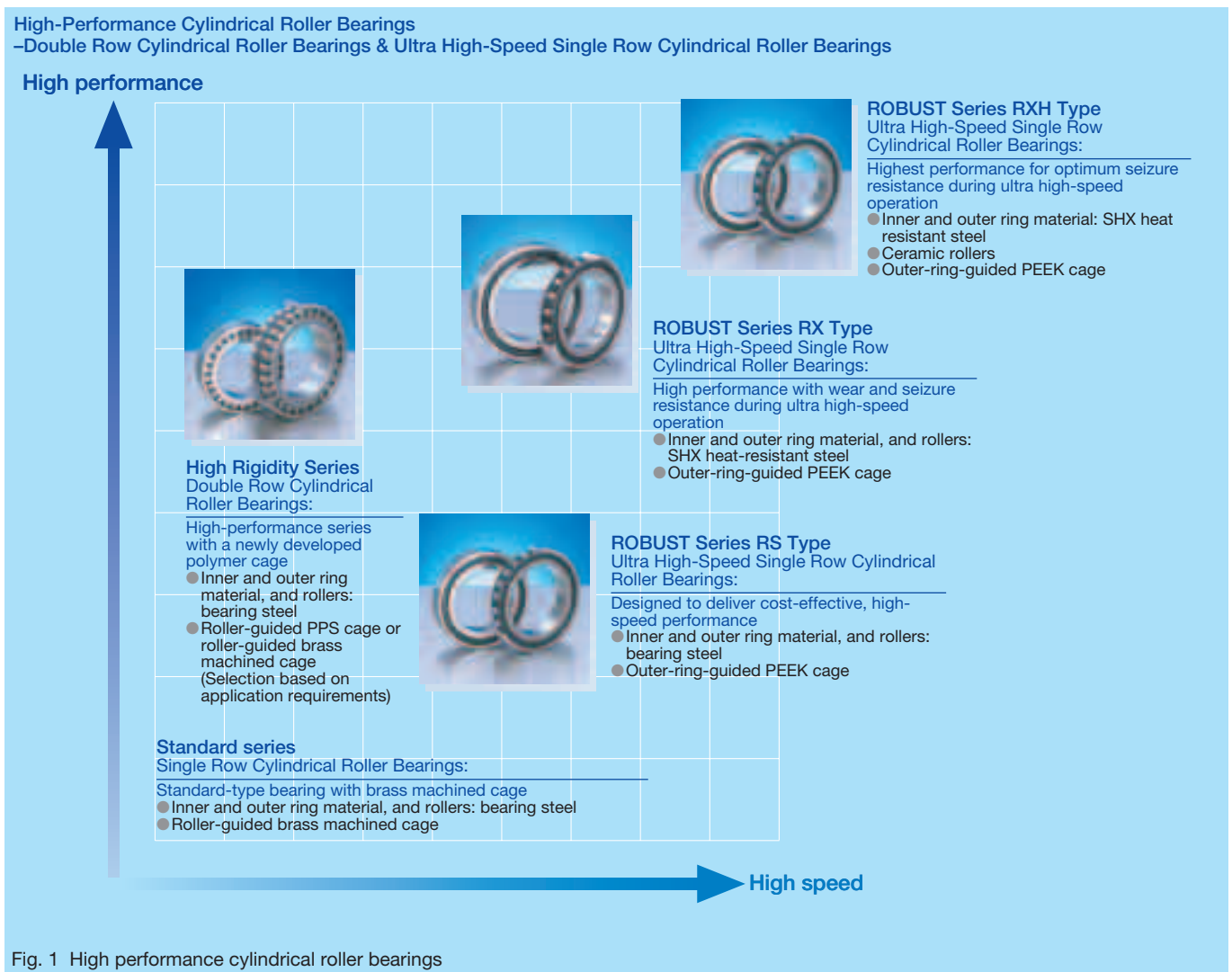

Fig. 1 High performance cylindrical roller bearings

that shows drastically longer life, quieter operation, higher operational speeds, less temperature rise, all these while maintaining high-accuracy.

## 1.2 Features

### 1.2.1 Longer life

Cage wear at initial operation was reduced and grease life extended by using PPS cage material, which has superior heat resistance and is highly rigid.

### 1.2.2 Quiet operation

In comparison to the brass-machined MB cage, our newly designed TB cage reduced the level of contact noise generated between the rollers and the cage when operating under insufficient lubricant conditions.

### 1.2.3 High-speed operations and low temperature rise

The molded cage has a simpler shape and higher accuracy. Deformation due to centrifugal force was further reduced while maintaining rotating stability. We achieved

a higher limiting speed of  $1 \times 10^6 d_m n$ , which was not possible with the conventional resin cage under grease lubrication.

### 1.2.4 Higher accuracy

By combining highly accurate cylindrical rollers, where the out-of-roundness and diameter differences are strictly controlled, we were able to achieve higher accuracy of center axis runout, which was difficult to achieve when using conventional JIS Class 4 bearings.

## 1.3 Specification

The TB cages are applicable for NN3006 to NN3024 (bore 30 mm to 120 mm). The limiting speed of a bearing using the TB cage is shown in Fig. 5.

## 1.4 Application

Double row cylindrical roller bearings are best suited for machine tool spindles that require high rigidity.



Fig. 2 High rigidity series double row cylindrical roller bearings

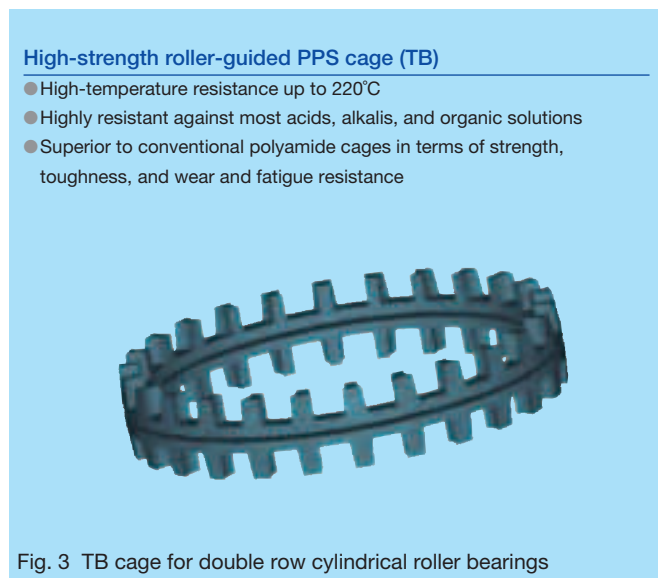

### High-strength roller-guided PPS cage (TB)

- High-temperature resistance up to 220°C
- Highly resistant against most acids, alkalis, and organic solutions
- Superior to conventional polyamide cages in terms of strength, toughness, and wear and fatigue resistance

Fig. 3 TB cage for double row cylindrical roller bearings

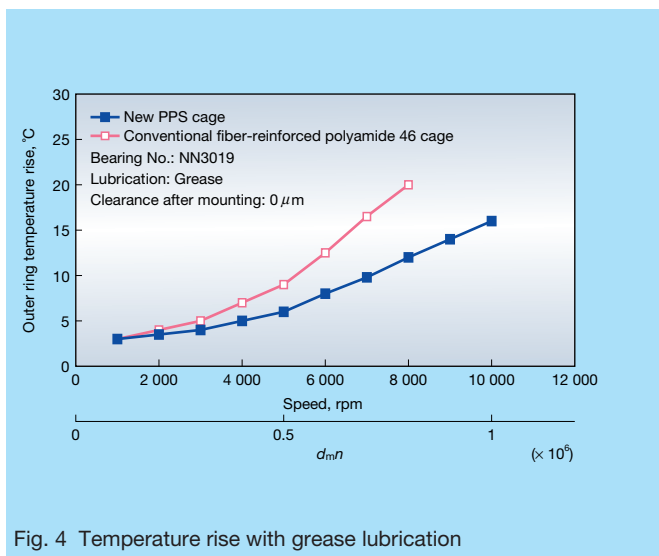

Fig. 4 Temperature rise with grease lubrication

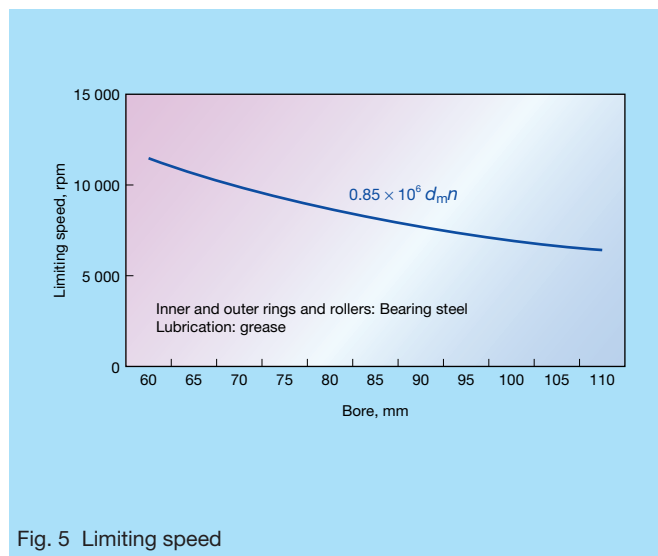

Fig. 5 Limiting speed

## 1.5 Summary

Customers and end users can benefit from longer life, quieter operations, higher speeds, less temperature rise, and higher accuracy for lathe main shaft applications by taking advantage of NSK's highly functional double row cylindrical roller bearings with TB cages.

## 2. ROBUST Series of Ultra High-Speed Single Row Cylindrical Roller Bearings

### 2.1 Background

Recent trends in machining centers have seen an increase of integral motorized spindles that provide users with machine tool spindles capable of 15 000 rpm. Most designs consist of grease lubrication or oil-air lubrication with a small amount oil lubrication being used for the main spindle. Whereas such configurations cannot use

Table 1 Types of ultra high-speed single row cylindrical roller bearings

Type	Material	
	Inner and outer rings	Rollers
RS	Bearing steel (SUJ2)	Bearing steel (SUJ2)
RX	Heat-resistant steel (SHX)	Heat-resistant steel (SHX)
RXH	Heat-resistant steel (SHX)	Ceramics ( $\text{Si}_3\text{N}_4$ )

cylindrical roller bearings, combination angular contact ball bearings became most commonly used for such applications.

Unlike angular contact ball bearings, cylindrical roller bearings can absorb heat expansion of the shaft. If high-speed operations were possible with cylindrical roller bearings on the rear side, the structure of the machine tool spindle could also be simplified by working in combination



Fig. 6 Robust series ultra high-speed single row cylindrical roller bearings

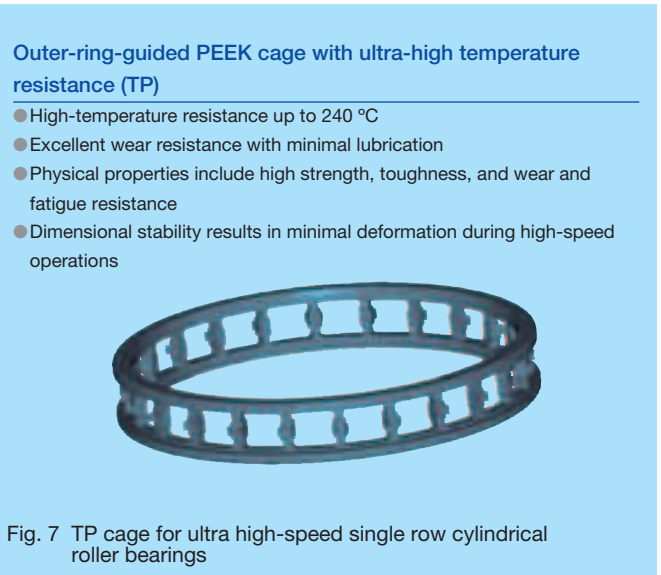

Fig. 7 TP cage for ultra high-speed single row cylindrical roller bearings

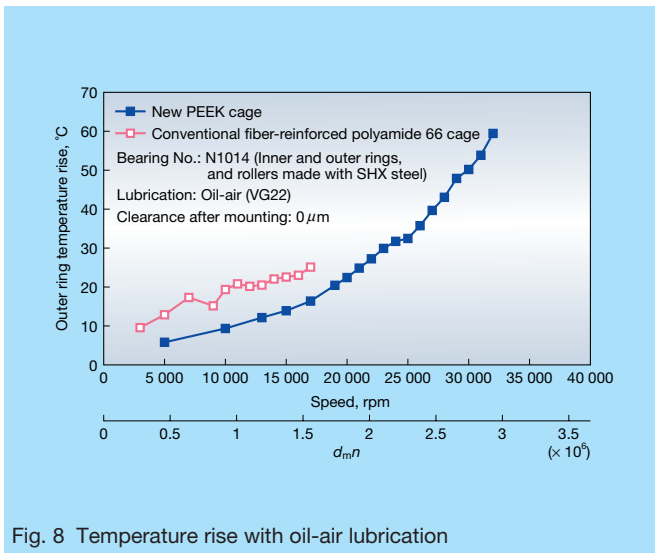

Fig. 8 Temperature rise with oil-air lubrication

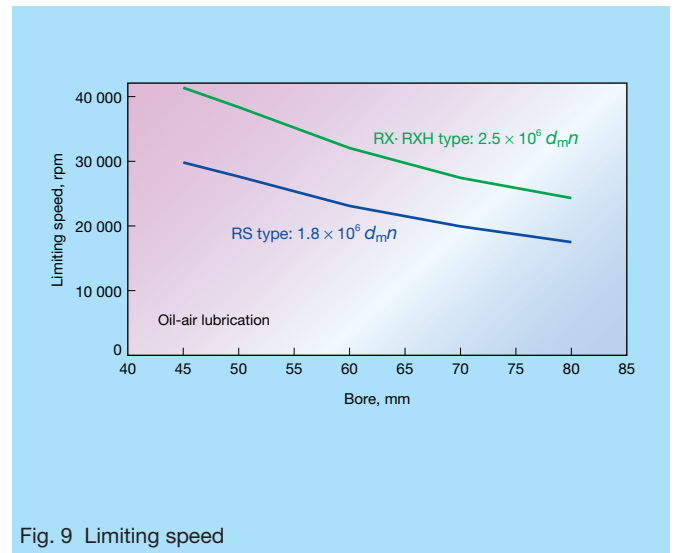

Fig. 9 Limiting speed

with angular contact ball bearings and position preload.

NSK has turned such a theory into a reality with its newly developed ROBUST series of ultra high-speed single row cylindrical roller bearings. These bearings achieve ultra-high speeds, low temperature rise, and incredibly improved performance (seizure resistance) by incorporating NSK's new and proprietary technologies.

## 2.2 Features

### 2.2.1 Ultra-high speeds and low temperature rise

The ROBUST series bearings take advantage of a heat-resistant polyether ether ketone (PEEK) resin material for the cage. Design of internal configuration of the bearing and configuration of the cage was focused on temperature robustness, resulting in achieving low temperature rise and ultra-high speed rotation with oil-air lubrication ( $3 \times 10^6 d_m n$ ).

### 2.2.2 Improved seizure resistance

Using NSK's specially developed SHX steel, seizure resistance was improved. RX type (SHX rollers) provides greater cost performance in comparison to RXH type (ceramic rollers).

### 2.2.3 Specification

TP cages are available for N1009 to N1017 bearings with a bore ranging from 45 mm to 85 mm. Three types of bearings are available (Table 1). RXH type bearings (with ceramic rollers) are recommended for maximum speed specifications. Limiting speed information is available in Fig. 9.

## 2.3 Application

Ultra high-speed single row cylindrical roller bearings are suitable for machine tool spindles used in high-speed operations.

## 2.4 Summary

Customers and end-users can achieve high-speed operations and higher reliability for their machine tool spindle applications by using ROBUST angular contact ball bearings with position preload on the front side, and ultra high-speed single row cylindrical roller bearings on the rear side. We are confident that this combination of NSK bearings will become the global standard for machining centers in the future.

# NSK RA Series Roller Guide

In the early 1980s, NSK developed and marketed the LY series precision linear guides for machine tool applications, which was followed with development of the LA series as a new series for machine tools. In response to demand for higher speed and higher accuracy of machine tools, such as in machining centers, the LA series incorporates features that were inherited from the LY series, and has demonstrated enhanced performance with well-balanced load capacity, rigidity, and friction force, which are achieved by increasing the number of raceways for rolling elements.

Recently, the demand for higher rigidity and greater load capacity of linear guides is continually increasing for the feed mechanism of machine tools. In response, roller linear guides adopting rollers as rolling elements have been increasing in applications such as lathes that have been mainly using slide ways for system rigidity, and for machine tools equipped with linear motors whose main drawback is attraction force created by strong magnets. Furthermore, increased application in machine tools is reinforced by the idea that the use of rollers gives a machine a more expensive look.

While functional requirements for machine tool guides, such as high capacity and high rigidity, are undoubtedly important, we cannot ignore the importance of greater

motion accuracy and higher operating characteristics, in addition to greater resistance to contamination under harsh operating conditions. NSK responded to such concerns by successfully developing and marketing the RA series roller guides; a new type of linear guide for machine tools with higher load capacity and greater rigidity than any other roller guide found in the market.

## 1. Features

The RA series (Photo 1) was developed with the same mounting dimensions as the LA series and other commercially available roller guides for full interchangeability. Other primary features of the RA series are provided in greater detail here.

### 1.1 High capacity

Load capacity of the RA series is superior to that of the LA series and other existing roller guides. This was achieved by maximizing roller diameter and roller length, while minimizing the chamfers at the end of the rollers.

### 1.2 High rigidity

An optimum cross section was implemented by optimal positioning of circulation holes in the roller slide body,

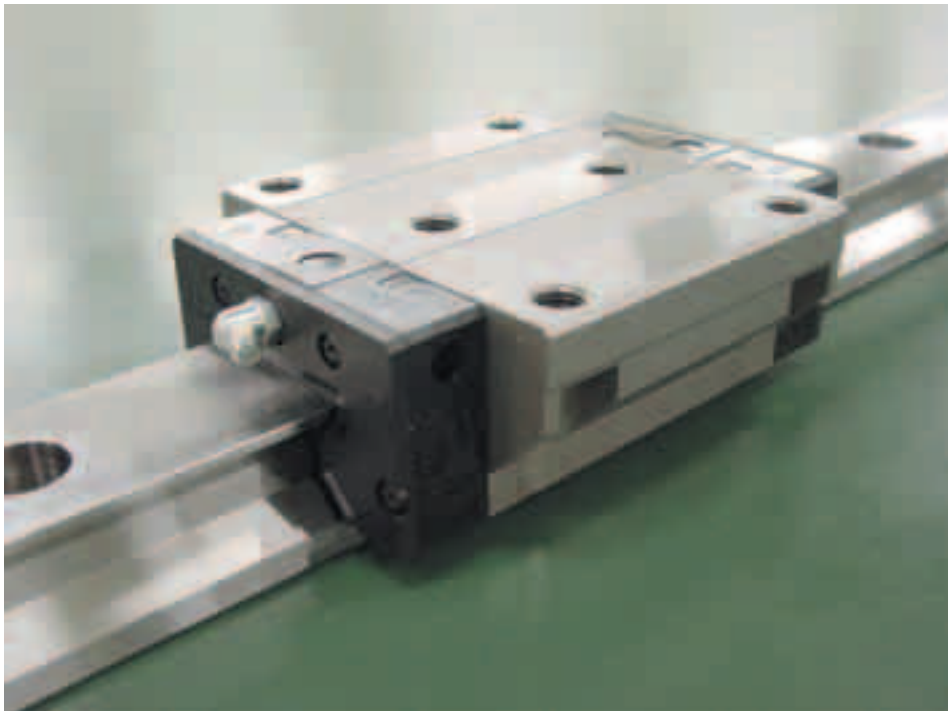
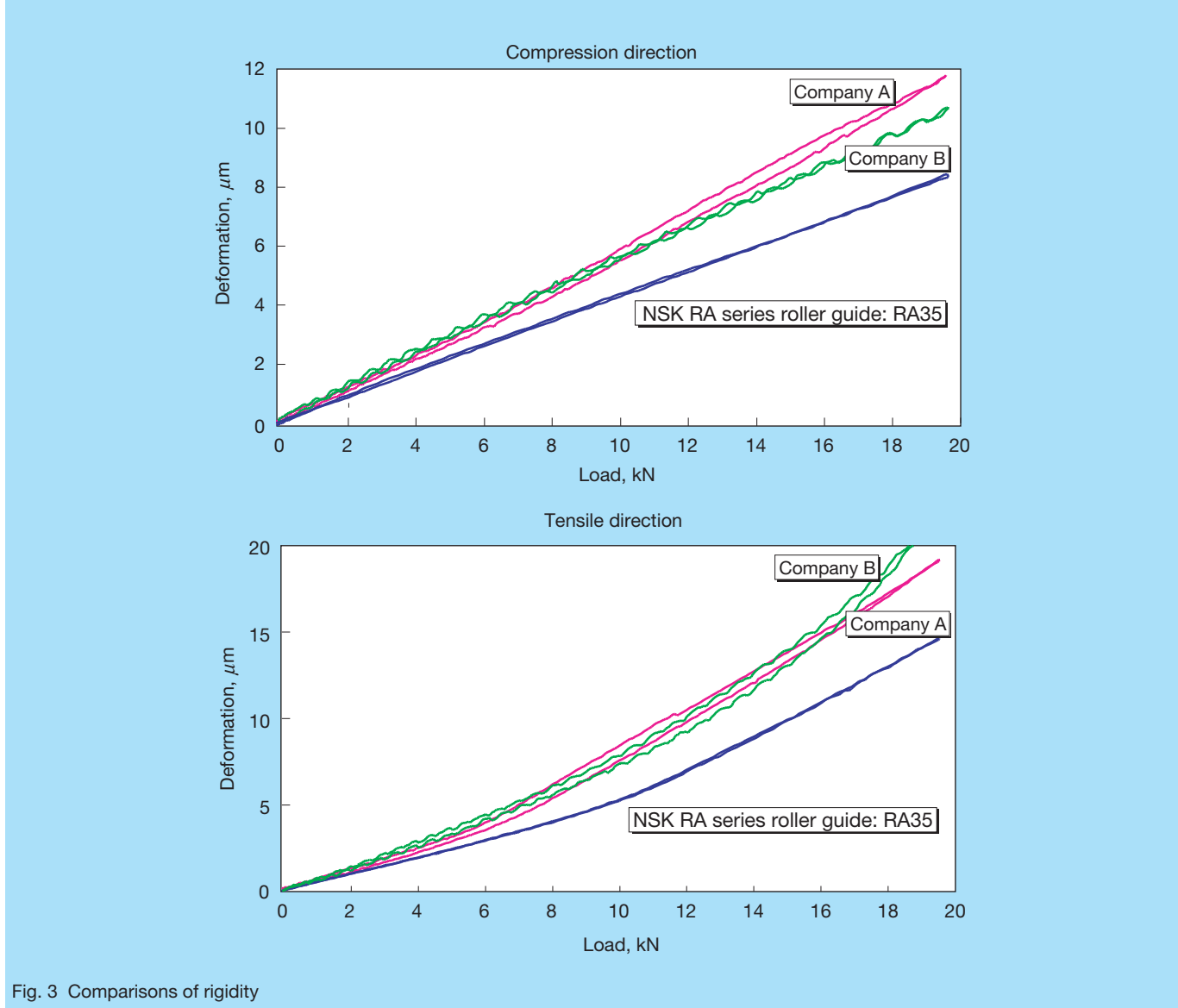
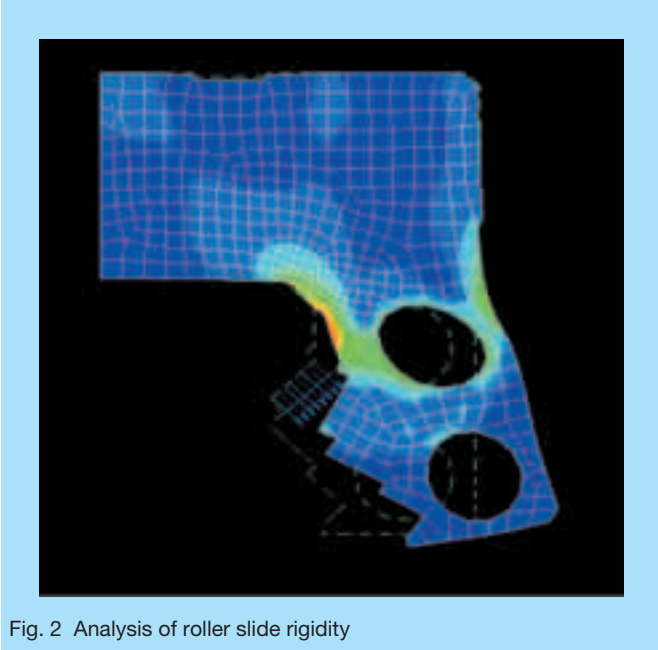
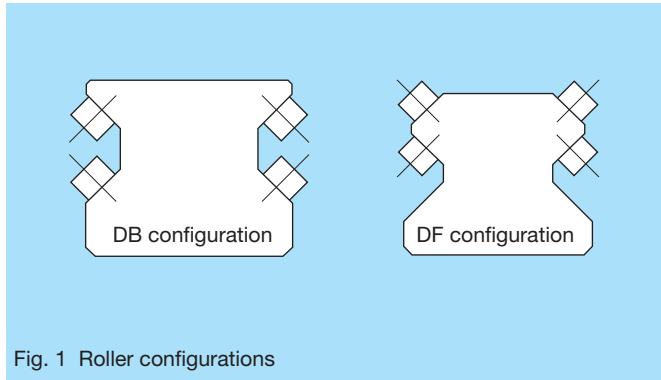

Photo 1 NSK RA series roller guide

setting rollers in a DB configuration instead of a DF configuration (Fig. 1), and by implementing internal detail dimensions in consideration of opening deformation of the roller slide body quantitatively. The end result is a roller guide with greater rigidity that is at least equal to or better than that of the LA series or other existing roller guides. FEM analysis of the RA series roller guide during



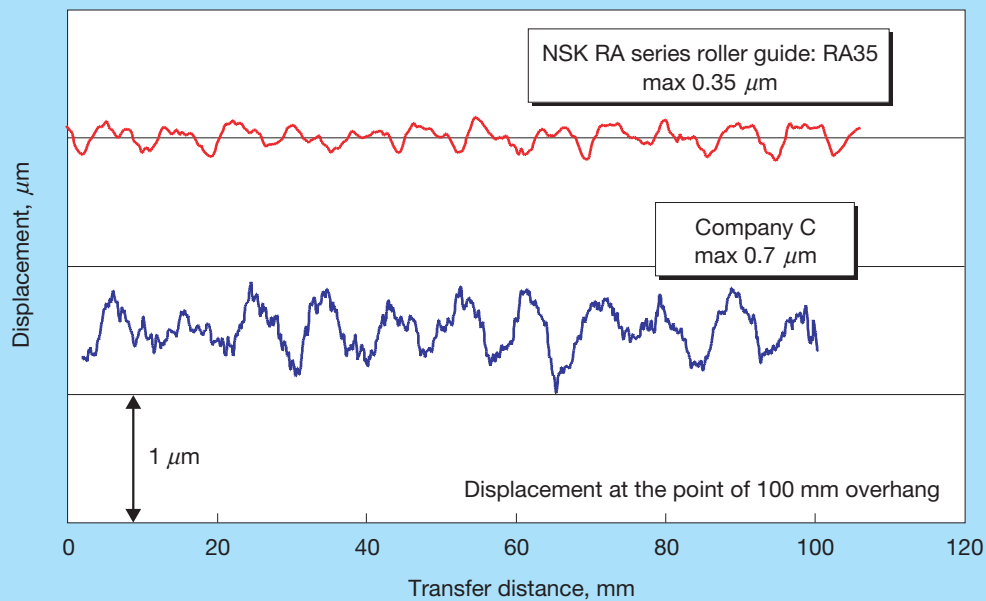

Fig. 4 Comparison of vibration caused by roller passage

the developmental stage was performed to determine the extent of roller slide deformation due to load. Analytical results (Fig. 2) proved noteworthy and invaluable in designing an optimal cross section of roller slide in addition to determining the raceway specifications.

We measured and compared the rigidity of NSK's RA35 roller guide with that of roller guides currently available in the marketplace (Fig. 3). Design specification of the RA35 roller guide performed as expected. Higher rigidity than the competition both in compression direction (roller slides pushed towards the rail) and tensile direction (roller slides pulled away from the rail) was achieved.

### 1.3 High motion accuracy

By designing optimum crowning at both ends of the rolling surface of the roller slide, we were able to restrain vibrations caused by roller passage, and were able to achieve high motion accuracy. We measured motion accuracy of the roller slide in a RA35 roller guide and that of current roller guides manufactured by the competition (Fig. 4). Results showed that vibration caused by roller passage was converted (magnified) to the displacement at the point of 100 mm overhang, and vibration caused by roller passage in the NSK roller guide was drastically reduced by half in comparison to vibrations found in competing products.

### 1.4 High operating characteristics

Skew motion, which is peculiar to rollers, was restrained by inserting retaining pieces between the rollers, thus achieving high operating characteristics. Furthermore, rollers with retaining pieces showed significantly improved retention in comparison to existing roller guides. In fact, there was no need to make large chamfers at the roller ends, which proven to be an advantage in regards to load capacity, rigidity, and cost.

### 1.5 High dust resistance

We achieved superior dust resistance under contaminated conditions by installing dustproofing seals around the rolling surface of the roller slide. A cover for the upper-rail surface supplies additional protection against harsh working environments.

## 2. Product Specifications

The RA series is currently available in three sizes RA35, RA45, and RA55 (from small to large cross sectional dimensions). They are classified into a high-capacity type (standard long roller slides) and a super high-capacity type (long roller slides), and each type is available with a square roller slide or flanged roller slide. Outside dimensions and mounting dimensions are interchangeable with LA35, LA45 and LA55 of the LA series and other roller guides found in the marketplace. In addition, RA series accuracy conforms to that of the LA series. Since the RA roller guide is inherently very rigid, differences in preload do not clearly affect overall guide rigidity, and thus roller slides in the RA series are all set in only one preload class to ensure sufficient rigidity.

## 3. Summary

NSK has successfully developed and marketed RA series roller guides to meet the demand for higher capacity and greater rigidity of machine tool guides. Our next goal is to make the RA25, RA30, and RA65 models available in an expanded product line, and to enhance their functions to meet or exceed the expectations of our customers.

# EPS Control Technology

Shuji Endo and Hideyuki Kobayashi  
NSK Steering Systems Co., Ltd.

## ABSTRACT

In this paper, we will discuss NSK's approach to electrical power steering (EPS) design by utilizing information related to road surface conditions. Information regarding varying road surface conditions includes both pertinent information and ineffective information, which can be separated by frequency. These frequencies can be utilized in designing an EPS system more effectively, in comparison to a conventional hydraulic power steering system. NSK has achieved a means of combining EPS design with information based on road surface conditions to create a robust EPS system. Furthermore, for this purpose, mechanical element designs such as a reduction gear, rack and pinion, and torque sensor are also described. The feasibility of our approach to design is also confirmed by experiments.

## 1. Introduction

Electrical power steering (EPS) systems have recently become more powerful than before, insomuch that it is now possible to expand their application to C-platform vehicles. At the same time, with applicable types of vehicles expanding, requirements related to steering performance are becoming more demanding. It is under these circumstances that NSK has developed EPS systems to serve as the ideal human-and-machine interface. The purpose of power steering is not only to provide powered assistance to the driver, but also to provide a means of conveying information to the driver of vehicle motion and road conditions. Based on the concepts and technologies we have developed thus far, NSK has further advanced developments in designing an EPS system that is able to achieve a proper sensitivity of road-surface information<sup>1)</sup>, which has since been deployed in EPS systems for vehicles in the European market where we have acquired a favorable reputation for serving the driver's need for precise and responsive steering. In this article, we will introduce NSK's latest development for achieving superior steering performance for EPS systems in the European market. Information related to NSK's earlier achievements in EPS systems<sup>2)</sup> are available on the Web at: <http://www.nsk.com/eng/journal/mc06/>

## 2. Road Information

Road information, which is the force generated by tires depending on the driving conditions, is transmitted to the driver via the steering mechanism. In order to maintain a safe and comfortable driving experience, the steering system must be designed to transmit desirable road information to the driver. For example, road information should be transmitted sufficiently to the driver, and flutter, which is due to unbalanced wheels, or steering vibration, synchronized with resonance of suspension, should be small.

In order to achieve these objectives, conventional hydraulic power steering systems use components such as

steering dampers. However, the frequency domain method can be adopted for designing EPS. Desirable and undesirable road information are distinguishable from each other in the frequency domain.

Table 1 shows the ranges of frequency of road information. The frequency of reaction force related to vehicle motion, which is most important to a steering system, is less than 10 Hz. Conversely, the frequencies of vibrations, which should be attenuated to a certain level for steering the automobile, are over 10 Hz. Such vibrations exceeding 10 Hz are referred to as flutter (shimmy), certain steering vibrations (related to resonance of suspension), and large reaction torque from the road surface (kickback torque).

Table 1 Frequency ranges of road information

Road information	Frequency
Resonant frequency of EPS mechanical components	10 Hz to 13 Hz
Resonant frequency of suspension	13Hz to 17Hz
Shimmy	15 Hz to 25 Hz
Reaction force of vehicle motion	0 Hz to 10 Hz (Main range)

Therefore, the sensitivity to road information can be designed using 10 Hz as a border frequency to distinguish between desirable and undesirable road information.

## 3. Road-Surface Information Sensitivity

Fig. 1 shows a simplified configuration of an EPS system. Road-surface information is transmitted from the tires through the EPS mechanism to the steering wheel and finally to the driver. Therefore, transfer characteristics from the tires to the steering wheel can be used to discuss road-information sensitivity. In Fig. 1, the motor, which generates power assist, is located at the



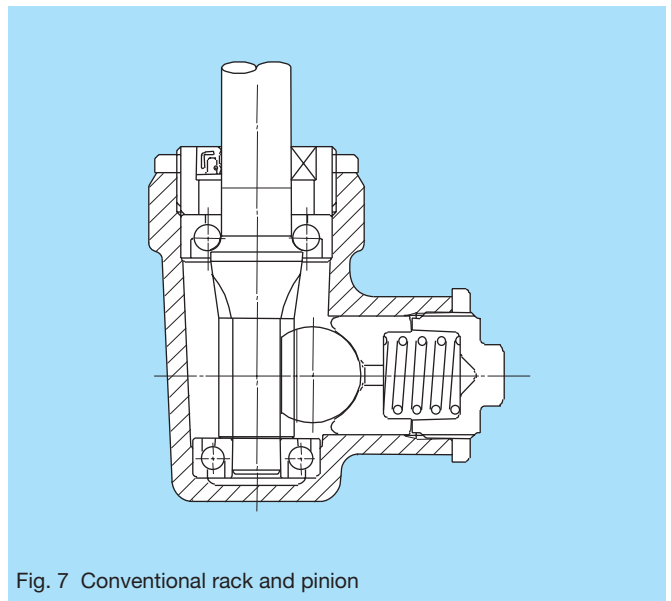
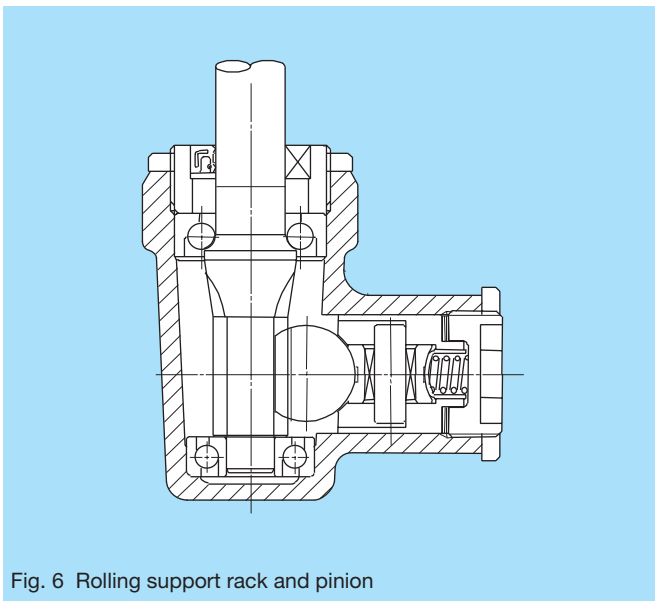
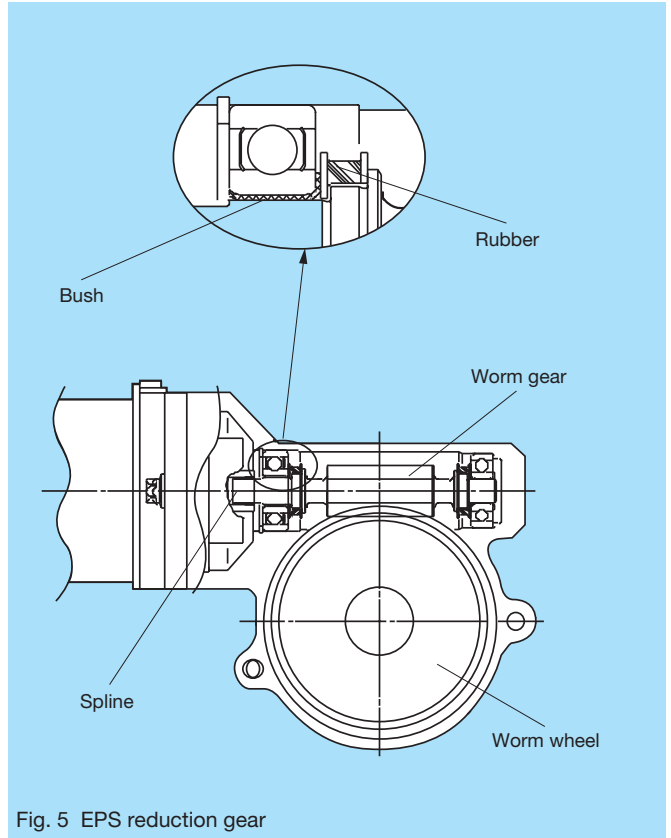
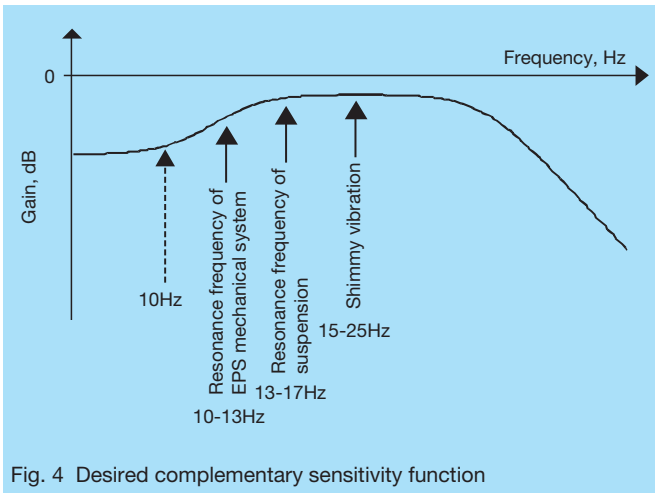
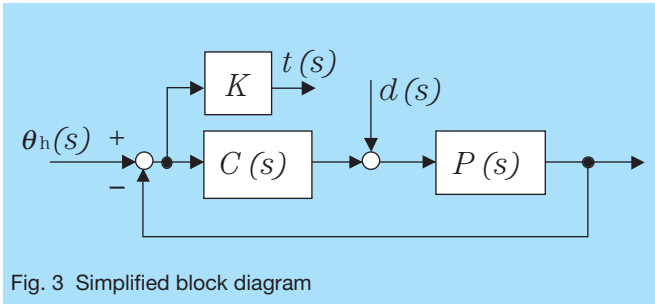

## 4. EPS Element Technology for Road-Surface Information Sensitivity Design

### 4.1 Rubber damper for EPS reduction speed gear

Fig. 5 shows a worm reduction gear used as a damping mechanism of the motor. Rubber dampers are inserted in the supporting sections of the worm gear where the rubber damper deforms elastically or where motor torque is small so that the motor shaft and the column shaft can move

individually. Under straight driving conditions with very little power-assist requirements, the rubber dampers perform the role of a clutch mechanism; the influence of motor friction or inertia does not affect the column shaft. Therefore, the road-surface information sensitivity design works effectively and improves the on-center feeling.

### 4.2 Rolling support rack and pinion

To make this design more effective, the adoption of a rolling support rack and pinion is recommended. In Fig. 6,

a rolling support rack and pinion is shown, and in Fig. 7, a conventional rack and pinion with pressure pad is also shown. As shown in Fig. 8, compared to conventional rack and pinions, rolling support rack and pinions are superior in transfer characteristics especially with the small axial force of the rack. By using this, the transmitting loss of the road-surface information becomes smaller and brings the road-surface information sensitivity design method into play.

### 4.3 Non-contact torque sensor

Regarding torque sensor design, the width of detected hysteresis, in particular, is taken into consideration. Fig. 9 shows the relation between steering torque ripple, which

can be compensated, and torque sensor hysteresis. It is necessary to reduce torque ripple to certain degree so that the driver feels enhanced smoothness of operation. In Fig. 10, a non-contact torque sensor is shown. By measuring torsion angle of the torsion bar with a non-contact structure, the hysteresis characteristics of less than 0.2 N·m can be realized.

## 5. Experimental Results

Here, validation results of the effects of road information sensitivity design method are described.

Initially, in order to confirm the effect of this design method, the measurement result of transfer characteristics from the rack load (almost equivalent to

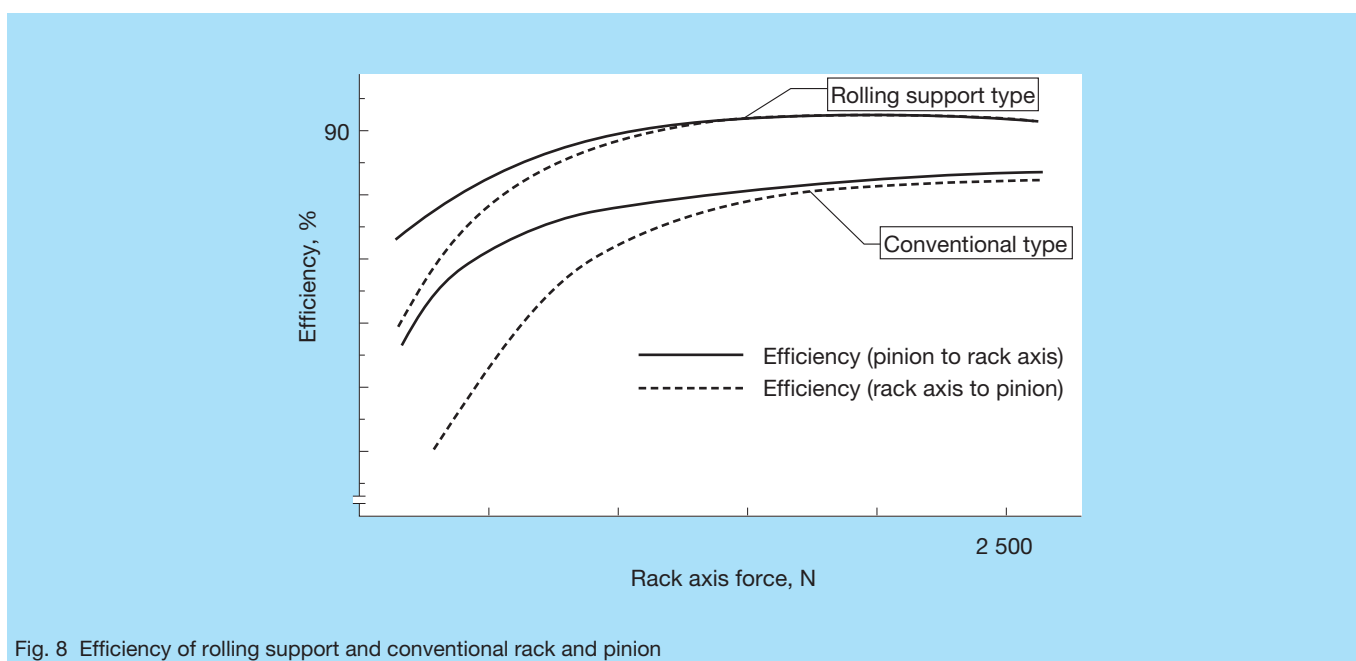

Fig. 8 Efficiency of rolling support and conventional rack and pinion

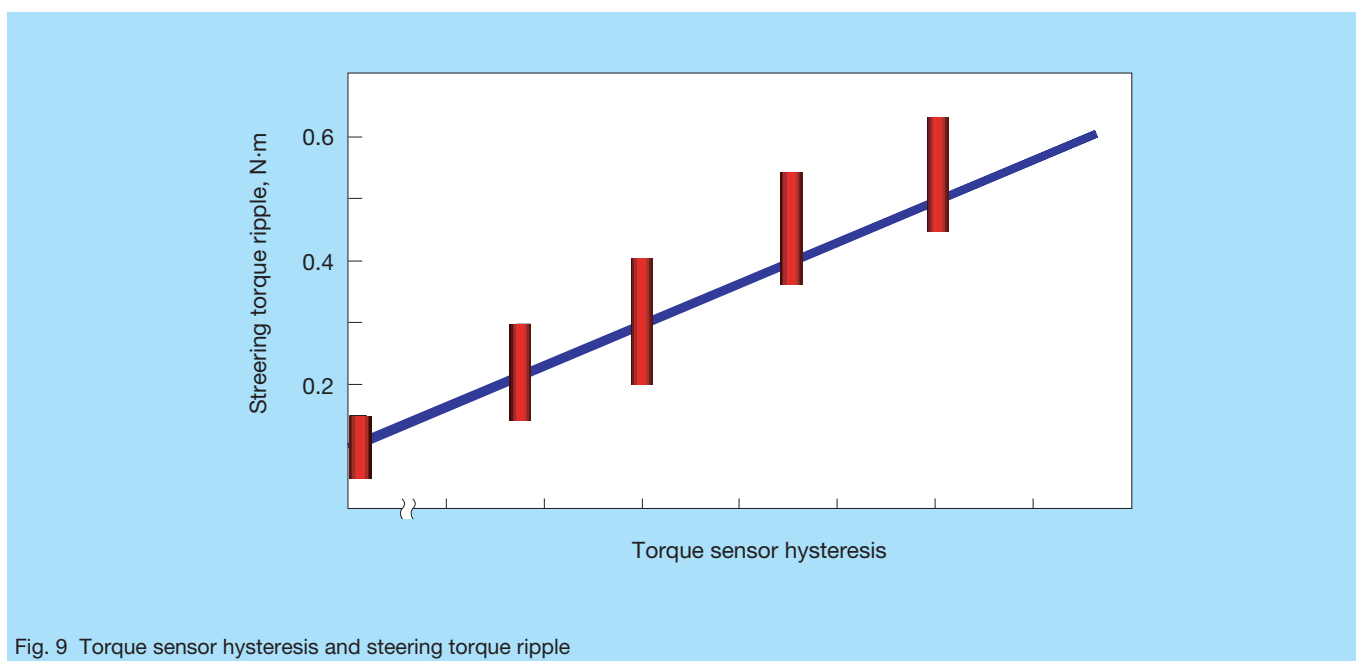

Fig. 9 Torque sensor hysteresis and steering torque ripple

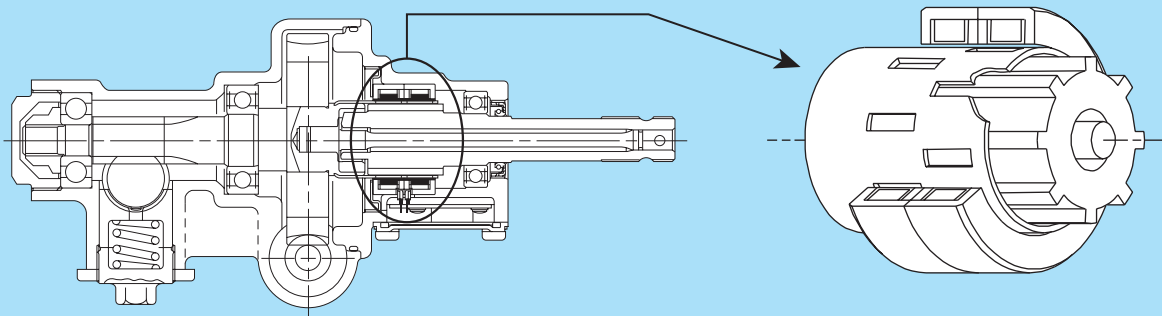

Fig. 10 Noncontact torque sensor

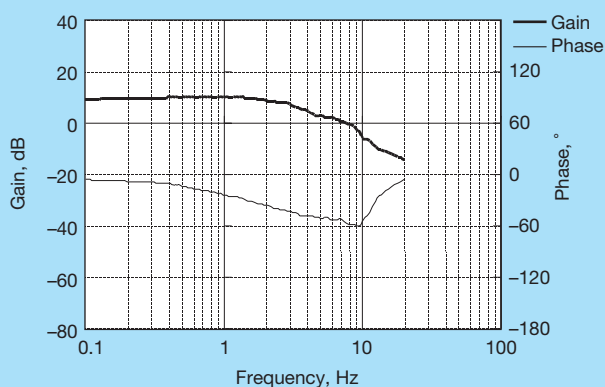

Fig. 11 Frequency response from rack load to steering torque

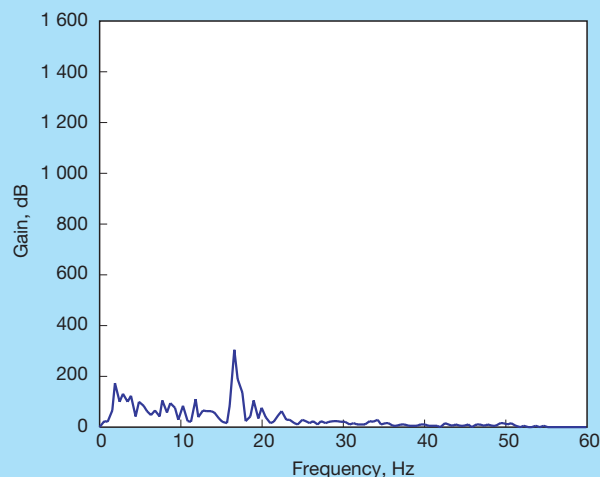

Fig. 12 Power spectrum of steering torque (EPS)

the torque generated at tires) to the steering torque is shown. In order to obtain the measurements, sinusoidal waves are input from the rack shaft, and the output torque generated at the torsion bar was measured. The result is shown in Figure 11.

According to Figure 11, it is understood that the transfer characteristics are the same as characteristics of a low-pass filter to attenuate the component of rack load exceeding 10 Hz.

In Figures 12 and 13, the effects of road information sensitivity design method on the steering wheel vibration related to resonance of suspension were verified. The steering torque of driving on a Belgian road was measured, and the power spectrums of hydraulic power steering and EPS were compared. In case of the hydraulic power steering, a 17 Hz peak was observed (resonant frequency of suspension). In case of the EPS, the height of the peak was one-fourth that of the hydraulic power steering system, and the characteristics of less than 10 Hz

were almost the same as that of the hydraulic power steering system.

In Figures 14 and 15, the effects of road information sensitivity design method on flutter were verified. The evaluation was done by steering torque hysteresis of the characteristics of steering angle and steering torque when a vehicle was driven at a speed of 120 km per hour with unbalanced front wheels. As a result, flutter was observed and steering feel was poor in the hydraulic power steering. In the EPS system, flutter was almost never observed. Since both Lissajous figures are very similar, except for flutter, we understand that the reaction force of vehicle motion is transmitted well by EPS as well as by hydraulic power steering.

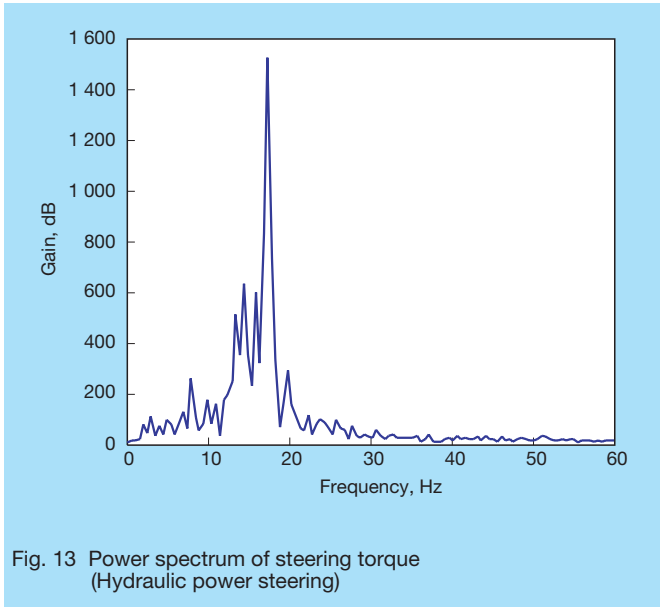

Fig. 13 Power spectrum of steering torque (Hydraulic power steering)

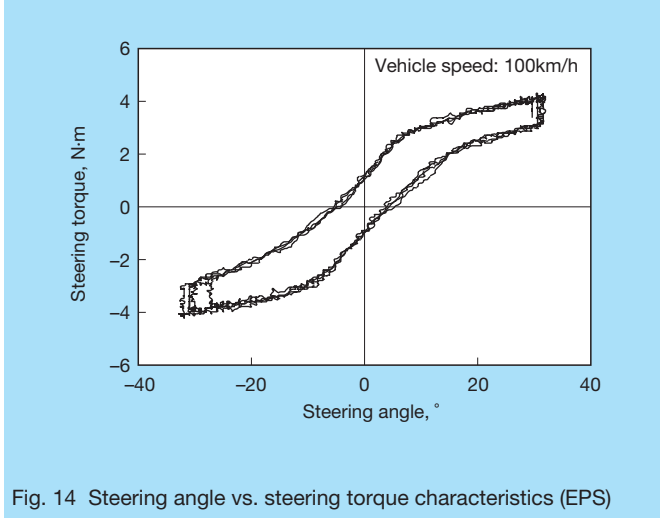

Fig. 14 Steering angle vs. steering torque characteristics (EPS)

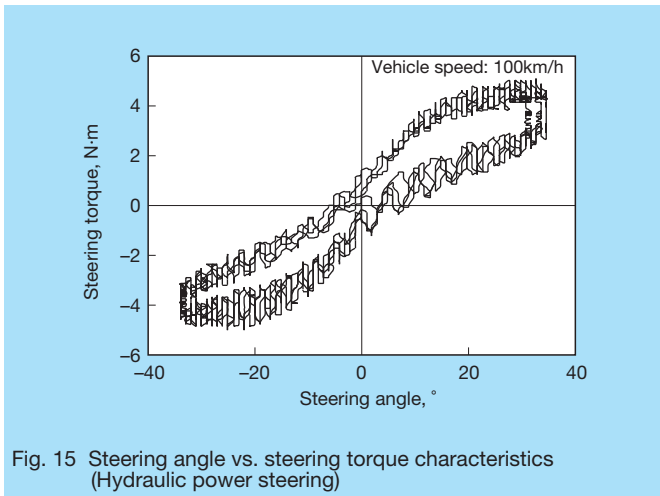

Fig. 15 Steering angle vs. steering torque characteristics (Hydraulic power steering)

## 6. Conclusion

The road-surface information sensitivity design method was introduced as a function that brings the feature of EPS into play, and the effect of it was compared with conventional hydraulic power steering and verified experimentally.

### Reference:

- 1) Shuji Endo, "Control Technology of Electrical Power Steering" Automotive Sensor and Actuator Technology (Material from the Japan Society of Mechanical Engineers), No. 00-33 (2000) 25-29
- 2) Yuji Kouzaki, Goro Hirose, Shozo Sekiya, and Yasuhiko Miyaura "Electrical Power Steering (EPS)" NSK Motion & Control, No. 6 (1999) 9-15



*Shuji Endo*



*Hideyuki Kobayashi*

# Step-and-Repeat Proximity Aligner for Production of Large-Sized LCD Glass Substrates

NSK has been manufacturing and selling step-and-repeat proximity aligners for the production of substrates for LCD color filters, using a single-axis step method in BM and RGB processes for the black matrix and the color layer of color filters of LCD glass substrates (730mm × 920mm) up to the fourth generation.

Since the color filter substrates are formed into liquid crystal panels by laminating with TFT substrates, it was essential to secure the accuracy of exposure positioning (total pitch).

However, it was more difficult to secure the total pitch of the larger glass substrates.

Since BM forms the base of a color filter substrate, it is especially necessary to acquire higher accuracy exposure technology than that of RGB.

Therefore, from the fifth generation, large glass substrates (1 300 mm × 1 300 mm) are manufactured using highly accurate aligners that scan using mirrors and lenses.

However, typical scan-type aligners are more expensive than step-type proximity aligners, resulting in the skyrocketing of capital investment.

In conventional single axis step proximity aligners, substrate-supporting parts of conventional mask holding mechanisms interfere with the work. This has made it necessary to use a larger mask, which extends beyond the short side of the glass substrates (Fig. 1), resulting in steeper running costs.

In order to reduce these costs, NSK succeeded with the development of an X-Y axes step-and-repeat proximity aligner for the production of large LCD glass substrates (fifth generation) by improving the design of the mask holding mechanism, and modifying the alignment mechanism.

NSK's new aligner (Photo 1) provides customers with an inexpensive and smaller mask in comparison to conventional single-axis step aligners, which helps meet the needs of larger substrates. Customers can further benefit from increased flexibility in exposure pattern layouts, and accurate exposure capability.

## 1. Outline

Maintaining a certain gap between the mask and the resist by leveling glass substrates to the mask, an illuminator (ultra-high pressure mercury arc lamp) exposes the photoresist by proximity printing.

In RGB exposure, the aligner has an automatic alignment mechanism for each color, that monitors the alignment mark on a glass substrate and the alignment mark on a mask for every exposure step.

In BM exposure, alignment of the mask to a standard mark is carried out beforehand.

Using this mask as the standard, the laser interference control system adjusts yaw components and step movement of a stage, and then the aligner exposes without alignment.

By incorporating these functions, total pitch accuracy of the exposure pattern on a substrate is improved, despite the movement of the stepper stage.

Our newly developed aligner includes the following:

- Aperture mechanism for limiting the exposure area at each step movement
- Automatic mask changing unit
- Glass substrate loading unit
- Glass substrate pre-alignment unit



Photo 1 RZ-800HX—Step-and-repeat proximity aligner

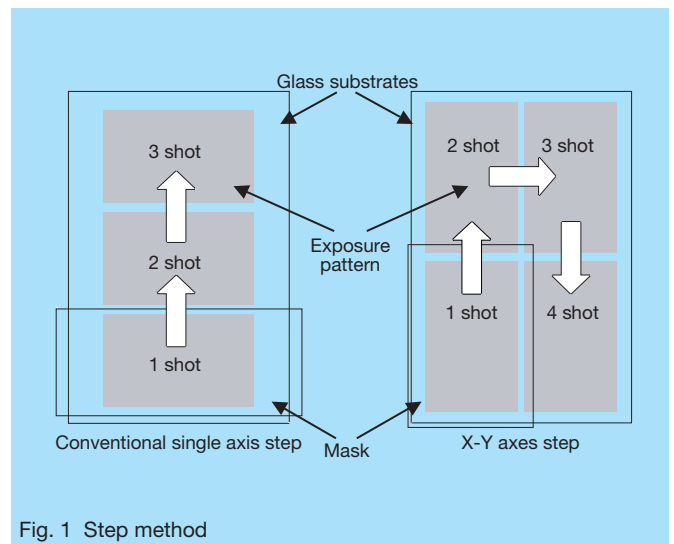

Fig. 1 Step method

Table 1 Specifications

Maximum substrate size	1 300 mm × 1 300 mm, t=0.7 mm, 1.1 mm
Total pitch accuracy	±3 μm
Alignment accuracy	≤±0.5 μm
Exposure tact	
First layer (6 shot)	81.9 s
Second layer (4 shot)	59.3 s
(Amount of exposure 150 mJ/cm <sup>2</sup> 12)	
Gap setting (sensor lower face)	≤±5 μm
Body mass	14 000 kg
Footprint	6 000 mm × 7 000 mm
Mask size	920 mm × 800 mm, t=10 mm
Thermal chamber standard option	Temperature setting ±0.1 °C, Class 10, (over 0.1 μm)
Light source	10 kW, two lamps
Effective exposure site	830 mm × 730 mm
Uniformity	±4 %
Minimum exposure amount	30 mJ/cm <sup>2</sup>

## 2. Main Specification

The main specifications of NSK's step-and-repeat proximity aligner for the production of large LCD glass substrates (RZ-800HX) are shown in Table 1.

## 3. Summary

With the growing trend for even larger LCD monitors and flat panel displays, development of substrates for real-world applications is also growing. The trend is towards greater market share of wall-mounted flat panel displays.

NSK is working hard to continue with further developments that will meet the needs of our customers (with quality products that offer good cost performance).



# Worldwide Sales Offices and Manufacturing Plants

**NSK LTD.-HEADQUARTERS, TOKYO, JAPAN** [www.nsk.com](http://www.nsk.com)  
Nissei Bldg. 1-6-3, OHSAKI SHINAGAWA-KU, TOKYO 141-8560, JAPAN  
ASIA BUSINESS STRATEGIC DIVISION-HEADQUARTERS  
P: 03-3779-7145 F: 03-3779-7433 C: 81  
INDUSTRIAL MACHINERY BEARINGS DIVISION-HEADQUARTERS  
P: 03-3779-7227 F: 03-3779-7644 C: 81  
AUTOMOTIVE DIVISION-HEADQUARTERS  
P: 03-3779-7189 F: 03-3779-7917 C: 81  
NEEDLE ROLLER BEARINGS STRATEGIC DIVISION-HEADQUARTERS  
P: 03-3779-7227 F: 03-3779-7917 C: 81  
PRECISION MACHINERY & PARTS DIVISION-HEADQUARTERS  
P: 03-3779-7219 F: 03-3779-7644 C: 81

## Africa

### South Africa:

#### NSK SOUTH AFRICA (PTY) LTD.

JOHANNESBURG 25 Galaxy Avenue, Linbro Business Park, Sandton, Gauteng,  
P.O. Box 1157, Kelvin, 2054 South Africa  
P: 011-458-3600 F: 011-458-3608 C: 27

## Asia and Oceania

### Australia:

#### NSK AUSTRALIA PTY. LTD. [www.nskaustralia.com.au](http://www.nskaustralia.com.au)

MELBOURNE 11 Dalmore Drive, Soresby, Victoria 3179, Australia  
P: (03) 9764-8302 F: (03) 9764-8304 C: 61  
SYDNEY Unit 1, Riverside Centre, 24-28 River Road West, Parramatta, N.S.W. 2150, Australia  
P: 02-9893-8302 F: 02-9893-8406 C: 61  
BRISBANE 91 Wellington Road, East Brisbane, Queensland 4169, Australia  
P: 07-3393-1388 F: 07-3393-1236 C: 61  
ADELAIDE 64 Greenhill Road, Wayville, South Australia 5034, Australia  
P: 08-9373-4819 F: 08-9373-4061 C: 61  
PERTH Unit 4, 36 Port Kembla Drive, Bibra Lake, Western Australia 6163, Australia  
P: 089-434-1311 F: 089-434-1318 C: 61

### China:

#### NSK HONG KONG LTD.

HONG KONG Room 512, Wing On Plaza, Tsim Sha Tsui East, Kowloon, Hong Kong  
P: 2739-9933 F: 2739-9323 C: 852

#### KUNSHAN NSK CO., LTD.

KUNSHAN 258 South Huang Pu Jiang Rd Kunshan E&T Development Zone Jiang Su 215335, China  
P: 0512-5771-5654 F: 0512-5771-5689 C: 86

#### GUIZHOU HS NSK BEARINGS CO., LTD.

ANSHUN Dongjiao, Anshun, Guizhou 561000, China  
P: 0853-3521505 F: 0853-3522722 C: 86

#### NSK STEERING SYSTEMS DONGGUAN CO., LTD.

DONGGUAN Dongguan, Guangdong Province High-tech Park, Shilong Road, Guanlong Section, Dongguan 523072, China  
P: 0769-242-7290 F: 0769-242-7183 C: 86

#### ZHANGJIAGANG NSK PRECISION MACHINERY CO., LTD.

JIANGSU Zhen Xin Rd, Zhangjiagang Economic Development Zone, Jiangsu 215600, China  
P: 0512-5867-6496 F: 0512-5818-0970 C: 86

#### TIMKEN-NSK BEARINGS (SUZHOU) CO., LTD.

JIANGSU Taishan Road 22 Suzhou New District, Jiangsu 215129, China  
P: 0512-6665-5666 F: 0512-6665-5766 C: 86

#### NSK CHINA TECHNOLOGY CENTER

JIANGSU 258 South Huang Pu Jiang Rd, Kunshan Economic & Technical Development Zone, Jiangsu 215335, China  
P: 0512-5771-5654 F: 0512-5771-0748 C: 86

#### NSK (SHANGHAI) TRADING CO., LTD.

SHANGHAI 10th Fl. Building No. A, Shanghai Far East International Plaza, Bldg. A 319 Xian Xia Road, Shanghai 200051, China  
P: 21-6235-0198 F: 21-6235-1033 C: 86

#### NSK REPRESENTATIVE OFFICES [www.nsk.com.cn](http://www.nsk.com.cn)

BEIJING Room 1001, Beijing Fortune Bldg., 5 Dong San Huan Bei Lu, Chao Yang District, Beijing 100004, China  
P: 010-6590-7810 F: 010-6590-7816 C: 86

#### SHANGHAI

10th Fl. Building No. A, Shanghai Far East International Plaza, 319 Xian Xia Road, Shanghai 200051, China  
P: 21-6235-0198 F: 21-6235-1033 C: 86

#### GUANGZHOU

Room 2701-02, Guangzhou International Electronics Tower 403,  
Huan Shu Rd East, Guangzhou 510095, China  
P: 020-8732-0583 F: 020-8732-0574 C: 86

#### ANSHUN

Dongjiao, Anshun, Guizhou 561000, China  
P: 0853-3522522 F: 0853-3522522 C: 86

#### CHENGDU

Room 1901, Giesse Land Hotel, No. 99 Zhongguo Xi Street, Chengdu, 610016, China  
P: 028-8661-4200 F: 028-8661-4343 C: 86

#### NSK (CHINA) INVESTMENT CO., LTD.

SHANGHAI 10th Fl. Building No. A, Shanghai Far East International Plaza, 319 Xian Xia Road, Shanghai 200051, China  
P: 21-6235-0198 F: 21-6235-1033 C: 86

## India:

#### RANE NSK STEERING SYSTEMS LTD.

CHENNAI 14, Rajagopalal Satal, Vallanchery Guduvancherry, Pin-603 202, India  
P: 04114-266002 F: 04114-266001 C: 91

#### NSK LTD. INDIA BRANCH OFFICE

CHENNAI 2A, First Street, Cenotaph Road, Chennai, 600 018, India  
P: 044-2433-4732, 044-2434-3036, 3067 F: 044-2433-4733 C: 91

## Indonesia:

#### PT. NSK BEARINGS MANUFACTURING INDONESIA

JAKARTA Blok M-4, Kawasan Berikat, MM2100, Industrial Town, Cikarang Barat,  
Bekasi 17520, Jawa Barat, Indonesia  
P: 021-898-0155 F: 021-898-0156, 021-898-0183 C: 62

#### PT. NSK INDONESIA

JAKARTA Sumatimas II 6th Fl., Jl. Jend. Sudirman Kav. 61-62, Jakarta 12190 Indonesia  
P: 021-252-3458 F: 021-252-3223 C: 62

## Korea:

#### NSK KOREA CO., LTD. [www.kr.nsk.com](http://www.kr.nsk.com)

SEOUL 9F (West Wing) Posco Center 892, Deachi 4 Dong Kangnam-Ku, Seoul, Korea  
P: 02-3287-0300 F: 02-3287-0345, 0445 C: 82

#### CHANGWON

60, Seongsan-Dong, Changwon, Kyungsangnam-Do, Korea  
P: 055-2811-7378 F: 055-285-9982 C: 82

## Malaysia:

#### NSK BEARINGS (MALAYSIA) SDN. BHD.

KUALA LUMPUR 1001, Level 10, Uptown 2, 2 Jalan SS21/37, Damansara Uptown,  
47400 Petaling Jaya, Selangor Darul Ehsan, Malaysia  
P: 03-772-3289 F: 03-7728-5543, 7728-7450 C: 60

#### PRAI

10, Lengkok Kikik 1, Taman Inderawasih, 13600 Prai, Penang, Malaysia  
P: 04-3991763 F: 04-3991830 C: 60

#### JOHOR BAHRU

Ground Floor, No. 27, Jalan Bakawali 50, Taman Johor Jaya,  
81100 Johor Bahru, Johor, Malaysia  
P: 07-3546290 F: 07-3546291 C: 60

#### KOTA KINABALU

Lot 10, Lrg. Kurma 4, Likas Ind. Centre, 5 1/2 Miles, Jalan Tuaran,  
88450 Inanam Sabah, Malaysia  
P: 088-421260 F: 088-421261 C: 60

#### NSK MICRO PRECISION (M) SDN. BHD.

MALAYSIA PLANT No. 43 Jalan Taming Dua, Taman Taming Jaya, 43300 Balakong, Selangor Darul Ehsan, Malaysia  
P: 03-8961-6288 F: 03-8961-6488 C: 60

## New Zealand:

#### NSK NEW ZEALAND LTD. [www.nsk-rhp.co.nz](http://www.nsk-rhp.co.nz)

AUCKLAND 3 Te Apunga Place Mt. Wellington, Auckland, New Zealand  
P: 09-276-4992 F: 09-276-4082 C: 64

## Philippines:

#### NSK REPRESENTATIVE OFFICE

MANILA Unit 919 Philippine AXA Life Centre, 1286 Seno Gil Puyat Avenue,  
Makati City 1200, Metro Manila, Philippines  
P: 02-759-6246 F: 02-759-6249 C: 63

## Singapore:

#### NSK INTERNATIONAL (SINGAPORE) PTE LTD.

SINGAPORE 2 Toh Guan Road East #02-02 Singapore 608837  
P: 6273-0357 F: 6275-8937 C: 65

#### NSK SINGAPORE (PTE) LTD.

SINGAPORE 2 Toh Guan Road East #02-03 Singapore 608837  
P: 6278-1711 F: 6273-0253 T: RS24058 C: 65

## Taiwan:

#### TAIWAN NSK PRECISION CO., LTD.

TAIPEI 9th Fl., 34, Chung Shan N. Rd., Sec. 3, Taipei, Taiwan R.O.C.  
P: 02-2591-0656 F: 02-2597-3101 C: 886

#### TAICHUNG

107-6, SEC. 2, Wenxin Rd., Taichung, Taiwan R.O.C.  
P: 04-2311-7378 F: 04-2311-2627 C: 886

#### TAINAN

No. 48, Lane 62, Fusing Rd., Sinsin Township, Tainan County 744, Taiwan, R.O.C.  
P: 06-589-2703 F: 06-589-2719 C: 886

## Thailand:

#### NSK BEARINGS (THAILAND) CO., LTD.

BANGKOK 25th Fl. RS Tower, 121/76-77 Rachadapisek Road, Dindaeng, Bangkok 10320, Thailand  
P: 02-6412-1500 F: 02-6412-161 C: 66

#### NSK BEARINGS MANUFACTURING (THAILAND) CO., LTD.

CHONBURI 700/430 Moo 7, Amata Nakorn Industrial Estate T. Donhualor,  
A. Muangchonburi, Chonburi 20000 Thailand  
P: 038-454010-454016 F: 038-454017, 454020 C: 66

#### SIAM NSK STEERING SYSTEMS CO., LTD.

CHACHOENGSAO 90 Moo 3, Wellknow Ind. Estate, Km. 36 Bangna-Trad Road, Bangwao,  
Bangpakong, Chachoengsao 24180, Thailand  
P: 038-522-343-350 F: 038-522-351 C: 66

## Europe

#### NSK EUROPE LTD. (EUROPEAN HEADQUARTERS) [www.eu.nsk.com](http://www.eu.nsk.com)

MAIDENHEAD, UK Belmont Place, Belmont Road, Maidenhead, Berkshire SL6 6TB U.K.  
P: 01628-509800 F: 01628-509808 C: 44

## France:

#### NSK FRANCE SAS

PARIS Quartier de l'Europe, 2 Rue Georges Guynemer, 78283 Guyancourt Cedex, France  
P: 01-30-57-39-39 F: 01-30-57-00-01 C: 33

## Germany:

#### NSK DEUTSCHLAND GMBH

DÜSSELDORF Harkortstrasse 15, 40880 Ratingen, Germany  
P: 02102-481-0 F: 02102-481-2290 C: 49

#### STUTT GART

Stielminger Str. 65, 70771 Leinfelden-Echterdingen, Germany  
P: 0711-79082-277 F: 0711-79082-289 C: 49

#### LEIPZIG

Zschortauer Str. 76, 04129 Leipzig, Germany  
P: 0341-5631241 F: 0341-5631243 C: 49

#### NSK PRECISION EUROPE GMBH

DÜSSELDORF Harkortstrasse 15, 40880 Ratingen, Germany  
P: 02102-481-0 F: 02102-481-2290 C: 49

#### NSK STEERING SYSTEMS EUROPE LTD.

STUTT GART Stielminger Strasse 65 D-70771 Leinfelden-Echterdingen, Germany  
P: 0711-79082-277 F: 0711-79082-289 C: 49

#### NEUEWEG FERTIGUNG GMBH

CORPORATE Ehinger Strasse 5, D-89597 Munderkingen, Germany  
OFFICE/PLANT P: 07393-540 F: 07393-5414 C: 49

## Italy:

#### NSK ITALIA S.P.A.

MILANO Via Garibaldi, 215, A-20024 Garbagnate Milanese (MI), Italy  
P: 02-99-5-19-1 F: 02-990-25-778, 02-990-28-373 C: 39

#### INDUSTRIA CUSCINETTI SPA

TORINO Via Giotto 4, 10080, S. Benigno C. se, Torino, Italy  
P: 0119824811 F: 0119880284 C: 39

## Netherlands:

#### NSK EUROPEAN DISTRIBUTION CENTRE B.V.

De Kroonstraat 38, 5048 AP Tilburg, Nederland  
P: 013-4647647 F: 013-4647648 C: 31

## Poland:

#### NSK EUROPE LTD. WARSAW LIAISON OFFICE

WARSAW LIAISON Przedstawicielstwo w Warszawie, ul. Migdalowa 4 lok. 73, 02-796 Warsaw, Poland  
OFFICE P: 222-645-1525, 1526 F: 022-6405-1529 C: 48

#### NSK ISKRA S.A.

CORPORATE Ul. Jagiellonska 109, 25-734 Kielce, Poland  
OFFICE/PLANT P: 041-366-5001 F: 041-366-5008 C: 48

#### NSK EUROPEAN TECHNOLOGY CENTER, POLAND OFFICE

UL. Jagiellonska 109, 25-734 Kielce, Poland  
P: 041-366-5812 F: 041-366-5206 C: 48

## Spain:

#### NSK SPAIN S.A.

BARCELONA Calle de la Hidráulica, 5, P.I. "La Ferreria" 08110 Montcada i Reixac (Barcelona), Spain  
P: 093-575-4041 F: 093-575-0520 C: 34

## Turkey:

#### NSK BEARINGS MIDDLE EAST TRADING CO., LTD.

ISTANBUL Fevzi Cakmak Caddesi, No.11/4, Maltepe 34844, Istanbul, Turkey  
P: 0216-442-7106 F: 0216-305-5505 C: 90

## United Kingdom:

#### NSK BEARINGS EUROPE LTD.

PETERLEE 3 Brindley Road, South West Industrial Estate, Peterlee, Co. Durham, SR8 2JD U.K.  
P: 0191-586-6111 F: 0191-586-3482 C: 44

#### NEWARK

Davey Drive, North West Industrial Estate, Peterlee, Co. Durham, SR8 2PW U.K.  
P: 0191-518-0777 F: 0191-518-0303 C: 44

#### NEWARK, UK

Northern Road, Newark, Nottinghamshire, NG24 2JF U.K.  
P: 01636-605123 F: 01636-642083 C: 44

#### NSK EUROPEAN TECHNOLOGY CENTRE

Northern Road, Newark, Notts, NG24 2JF U.K.  
P: 01636-605123 F: 01636-643241 C: 44

#### NSK UK LTD.

NEWARK Northern Road, Newark, Nottinghamshire, NG24 2JF U.K.  
P: 01636-605123 F: 01636-643050 C: 44

#### NSK STEERING SYSTEMS EUROPE LTD.

CORPORATE Silverstone Drive, Rowley Green, Coventry, CV6 6PA U.K.  
OFFICE P: 024-76-588588 F: 024-76-588599 C: 44

#### PETERLEE

PLANT 6/7 Doford Drive, South West Industrial Estate, Peterlee, Co. Durham, SR8 2RL U.K.  
P: 0191-518-6400 F: 0191-518-6421 C: 44

## North and South America

#### NSK AMERICAS, INC. (AMERICAN HEADQUARTERS)

ANN ARBOR 4200 Goss Road, Ann Arbor, Michigan 48105-2703, U.S.A.  
P: 734-913-7500 F: 734-913-7511 C: 1

## Argentina:

#### NSK ARGENTINA SRL

BUENOS AIRES Garcia del Rio 2477 PISO 7º OF. "A" C1429DEA-Buenos Aires-Argentina  
P: 11-4704-5100 F: 11-4704-0033 C: 54

## Brazil:

#### NSK BRASIL LTDA. [www.br.nsk.com](http://www.br.nsk.com)

SAO PAULO Rua Treze de Maio, 1634-14º Andar-Bela Vista São Paulo-SP, Brazil 01327-905  
P: 011-3269-4723 F: 011-3269-4720 C: 55

#### SUZANO PLANT

Av. Vereador João Batista Filizpaldi, 66-Vila Maluf Suzano-SP, Brazil 08685-000  
P: 011-4741-4090 F: 011-4748-2355 C: 55

#### BELO HORIZONTE

Rua Ceará 1431-4º andar-sala 405-Funcionários Belo Horizonte-MG, Brazil 30150-311  
P: 031-3274-2477 F: 031-3273-4408 C: 55

#### JOINVILLE

Rua Blumenau, 178-sala 910-Centro Joinville-SC, Brazil 89204-250  
P: 047-422-5445/433-3627 F: 047-422-2817 C: 55

#### PORTO ALEGRE

Av. Cristovão Colombo, 1694-sala 202-Floresta Porto Alegre-RS, Brazil 90560 001  
P: 051-3322-1324/3345-7851 F: 051-3322-2599 C: 55

#### RECIFE

Av. Conselheiro Aguiar, 2738-6º andar-coin, 604-Boa Viagem Recife-PE, Brazil 51020-020  
P: 081-3326-3781 F: 081-3326-5047 C: 55

## Canada:

#### NSK CANADA INC. [www.ca.nsk.com](http://www.ca.nsk.com)

HEAD OFFICE 5585 McAdam Road, Mississauga, Ontario, Canada L4Z 1N4  
P: 562-926-2975 F: 905-890-3588 C: 1

#### MONTREAL

2150-32E Avenue, Lachine, Quebec, Canada H8T 3H7  
P: 514-633-1220 F: 514-633-8164 C: 1

#### EDMONTON

5585 McAdam Road, Mississauga, Ontario, Canada L4Z 1N4  
P: 905-890-3588 F: 905-890-1938 C: 1

#### TORONTO

9267-41st Avenue, Edmonton, Alberta, Canada T6E 6R5  
P: 604-294-11

# **Motion & Control**

## ***No.16 August 2004***

Published by NSK Ltd.



Printed on 100% recycled paper.