

MEGATORQUEMOTOR™

PS Series

UL Standard and CE Marking Conformed

The Megatorque Motor PS Series delivers unprecedented performance, including a maximum rotational speed of 10 [s⁻¹] and position sensor resolution of 2 621 440 [counts/rev].



Patent Pending

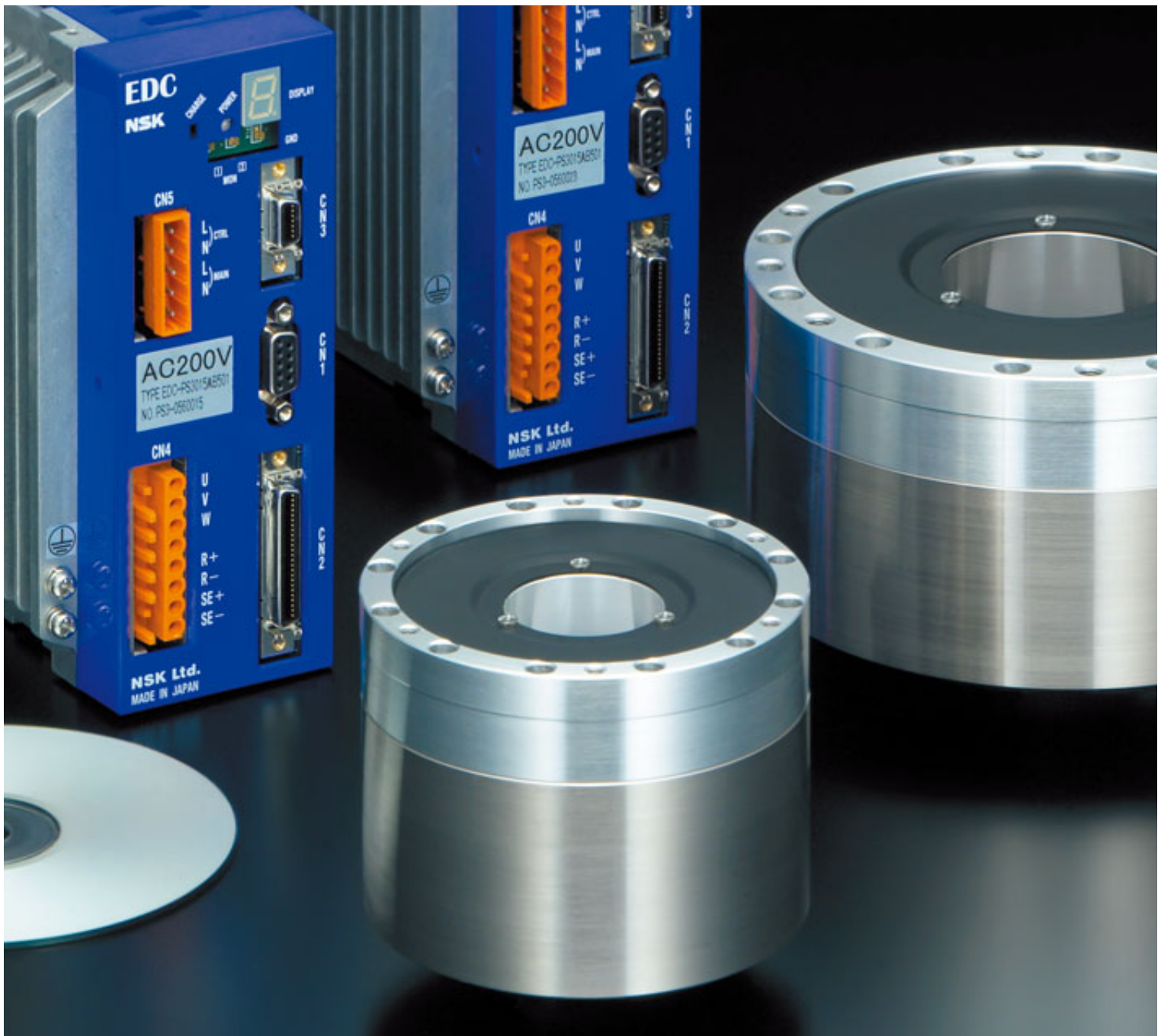

Advanced Megatorque Motor PS Series, with high-speed and high-resolution capabilities.

Capable of a maximum rotational speed of 10 [s⁻¹] and position sensor resolution of 2 621 440 [counts/rev] simultaneously, The PS Series Motor offers high accuracy, high torque, light weight, and compactness. These innovative direct drive motors are highly accurate, light and compact, and increase the productivity of various devices such as high-speed robot arms.

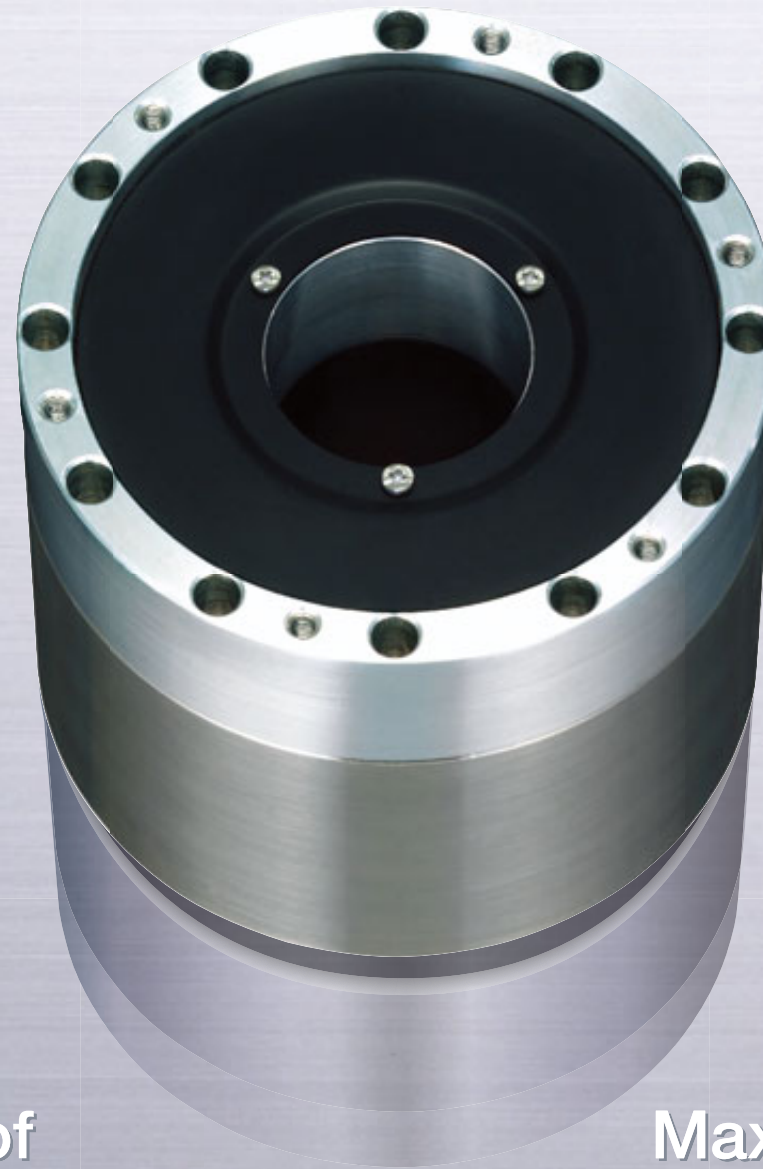

1 Shortened Positioning Time

A new servo algorithm shortens the settling time to less than one-fifth of that of conventional NSK Motors.^{*1)}

Maximum rotational speed: **10** [s⁻¹]

Settling time: Less than **1/5**

2 Compact Motor

NSK's advanced design technology creates a compact motor with an outer diameter of 100 [mm] (PS1 model Motor) and upgraded functionality. The optimal magnetic field design gives it more than twice as much force density as conventional NSK motors.

Motor outer diameter: **φ100** [mm]

Force density: **Twice** as much

3 Interchangeable, Highly Accurate Absolute Position Sensor

The PS Series Motor incorporates an absolute position sensor with positioning accuracy of 90 arc seconds, requiring no homing operations. The interchangeable Motors and Driver Units can be combined freely.

Sensor accuracy: **90** [arc seconds]
Ambient temperature: 25 ± 5 [°C]

4 Compact Driver Unit

Combined with a special module, the Driver Unit body is 65% smaller than conventional NSK units.

65 [%] smaller



Position sensor resolution of

2 621 440 [counts/rev]

Maximum rotational speed of

10 [s⁻¹]^{*1)}

^{*1)} Maximum rotational speed varies with Motor model.

Megatorque Motor PS Series

Features of PS Series Motors

Control Technology of PS Series Motors

- Adopts a **friction compensation control** to reduce the settling time
- Adopts a **high-performance tracking controller** to minimize following errors

High-speed positioning with a settling time of 1 [ms]

Results of 180 [°] Positioning of a PS Series Motor

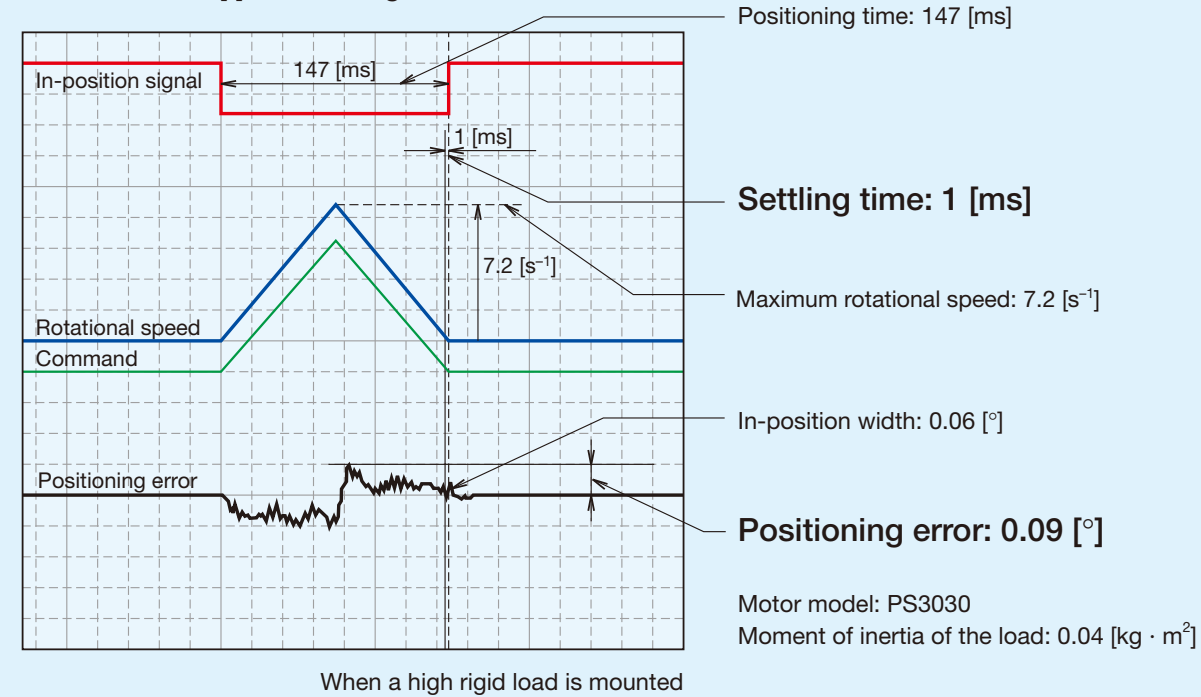

180° positioning of the PS Series compared against a competitor

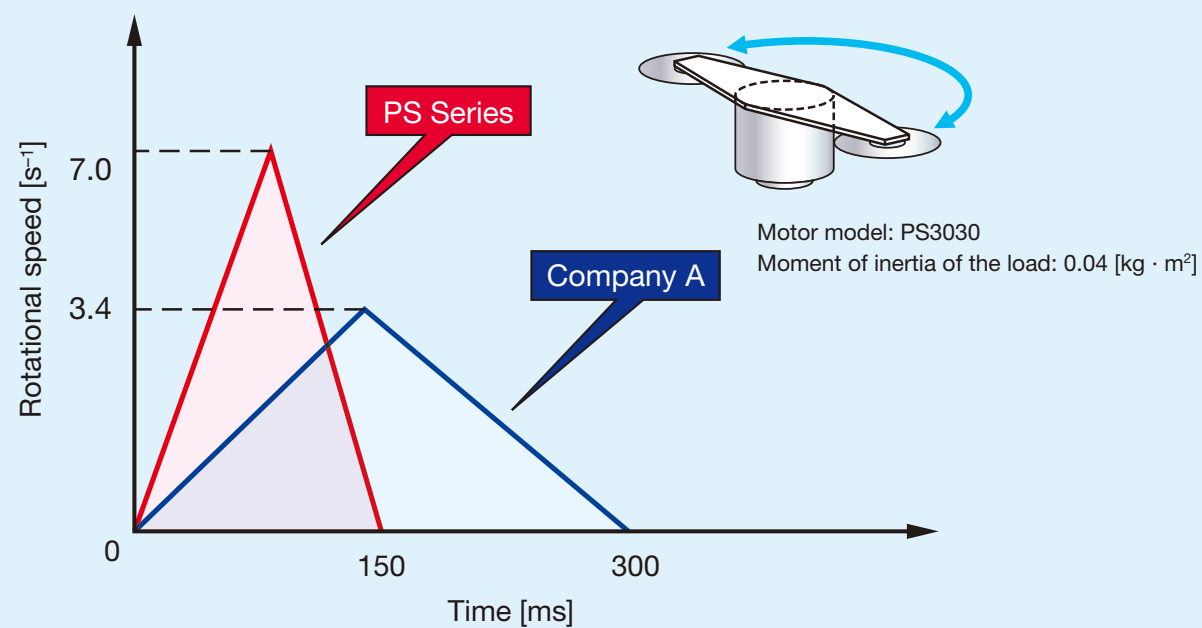

Applications and System Configuration

Applications

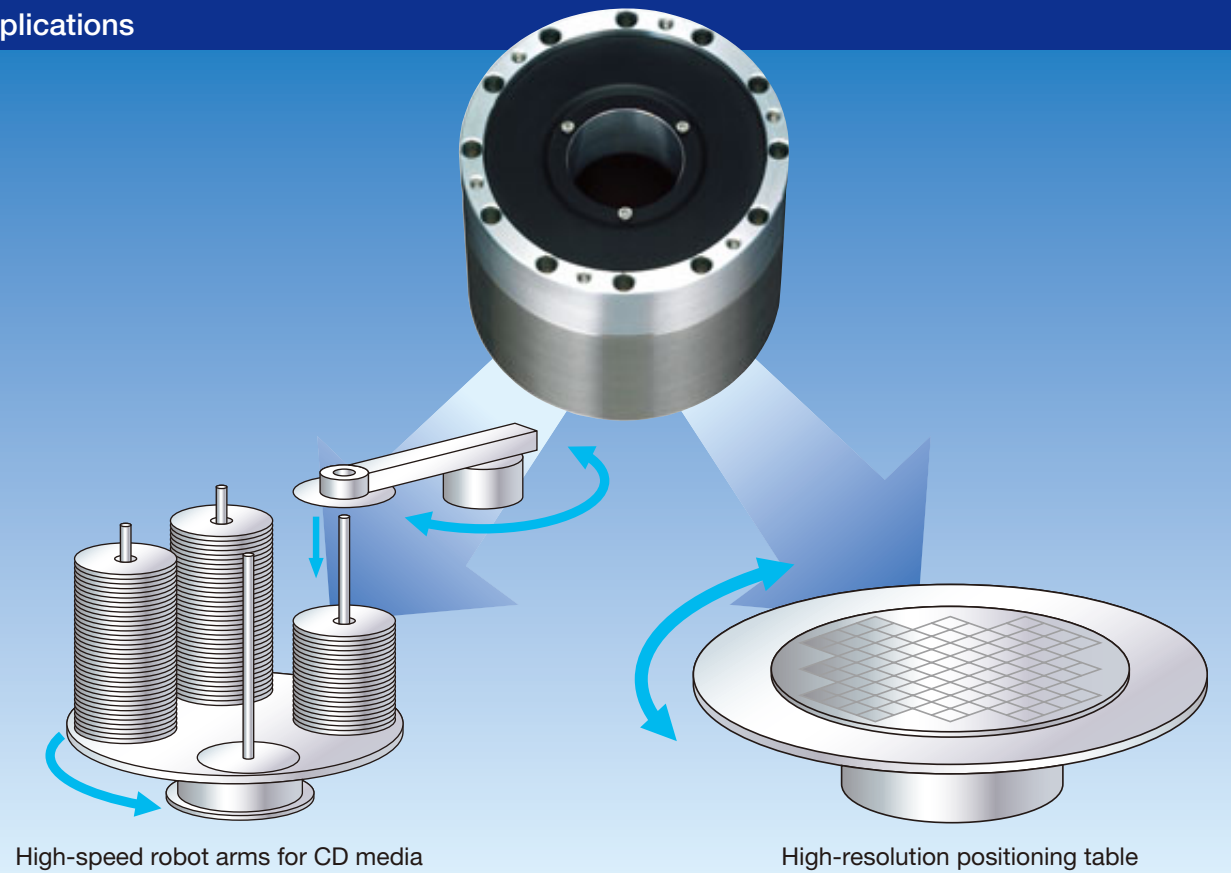

System Configuration

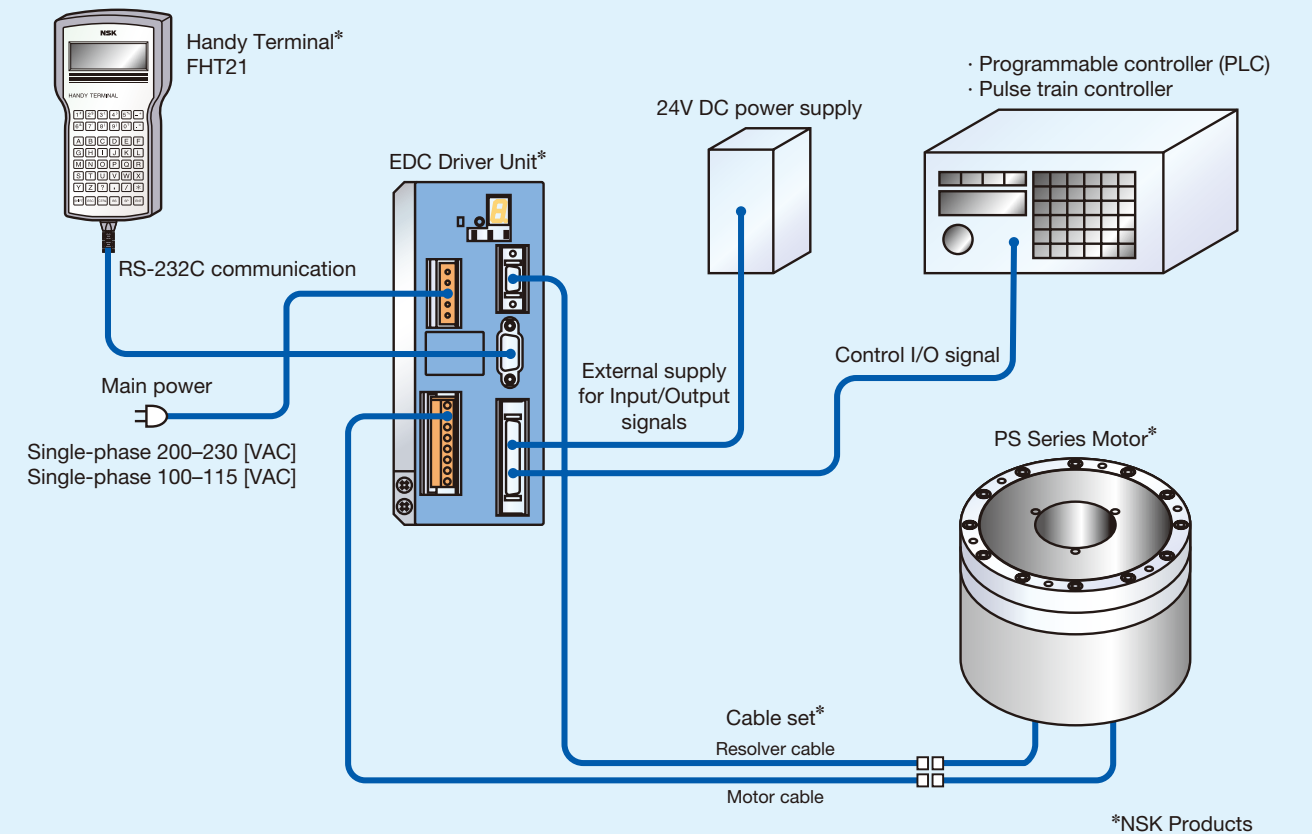

1. Motor Specifications

PS1 Model Motor

1.1 Coding for Motor Reference Number

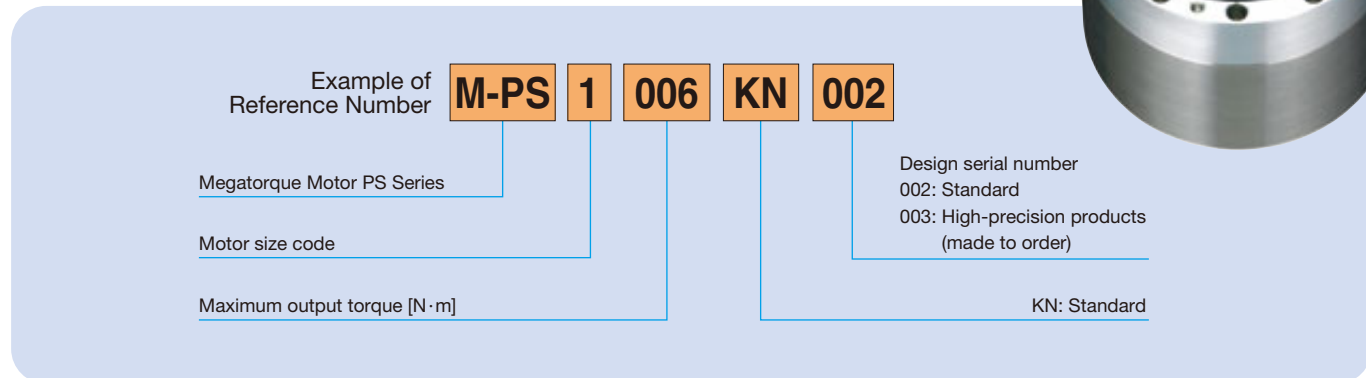

1.2 PS 1 Model Motor Specifications

Functional item	Reference number	M-PS1006KN002	M-PS1012KN002	M-PS1018KN002
Motor outer diameter [mm]		φ100		
Maximum output torque [N·m]		6	12	18
Rated output torque [N·m]		2	4	6
Motor height [mm]		85	110	135
Motor hollow diameter [mm]		φ35		
Maximum rotational speed [s ⁻¹]		10		
Rated rotational speed [s ⁻¹]		5		
Resolution of position sensor [counts/rev]		2 621 440		
Absolute positioning accuracy [arc sec]*1		90 (interchangeable type, ambient temperature: 25 ± 5 [°C])		
Repeatability [arc sec]		±2		
Allowable axial load [N]		1 000 (under no radial load)		
Allowable radial load [N]		820 (under no axial load)		
Allowable moment load [N·m]		28		
Rotor's moment of inertia [kg·m ²]		0.0024	0.0031	0.0038
Recommended load's moment of inertia [kg·m ²]		0.015–0.24	0.03–0.31	0.03–0.38
Mass [kg]		2.4	3.5	4.5
Environmental conditions		Ambient temperature 0–40 [°C]; humidity: 20–80%; use indoors, free from dust, condensation and corrosive gas. IP30 equivalent.		

Note: Please consult with NSK in case of a simultaneous application of axial load, radial load and moment load to a Motor.

For an oscillating operation less than 45 [°], turn the Motor 90 [°] or more at least once a day.

*1: Absolute positioning accuracy of high-precision products (made to order) is 30 [arc sec]. (interchangeable type, ambient temperature of 25 ± 5 [°C]).

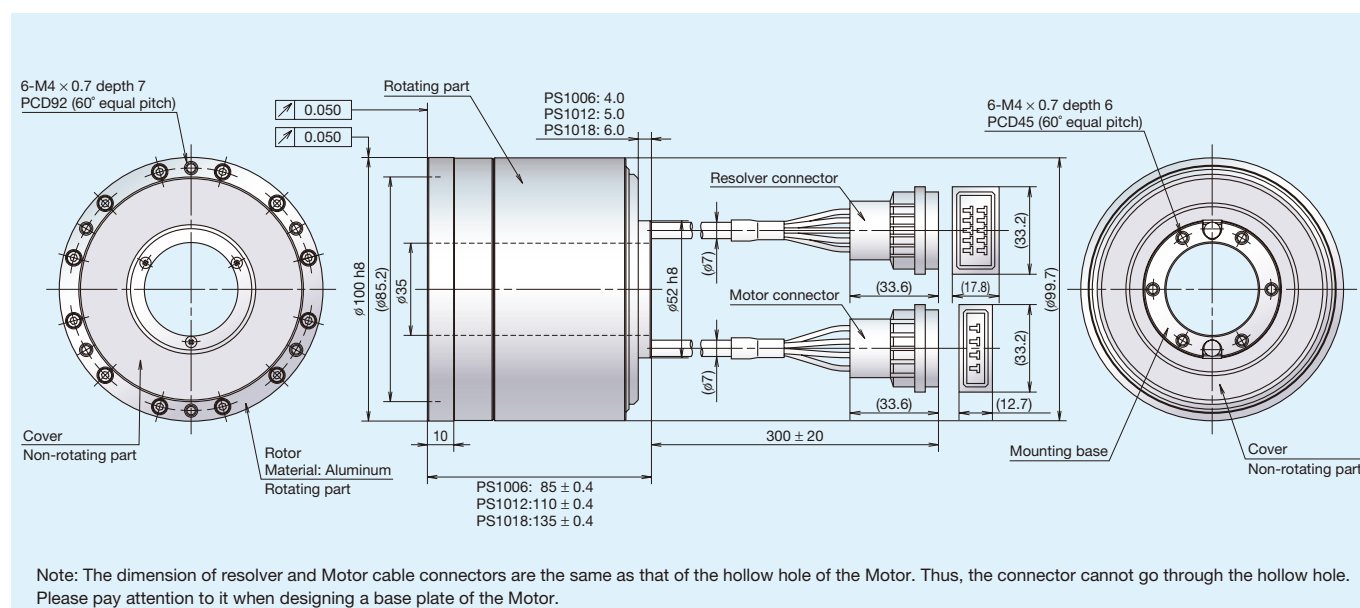

Note: The dimension of resolver and Motor cable connectors are the same as that of the hollow hole of the Motor. Thus, the connector cannot go through the hollow hole. Please pay attention to it when designing a base plate of the Motor.

PS3 Model Motor

1.3 Coding for Motor Reference Number

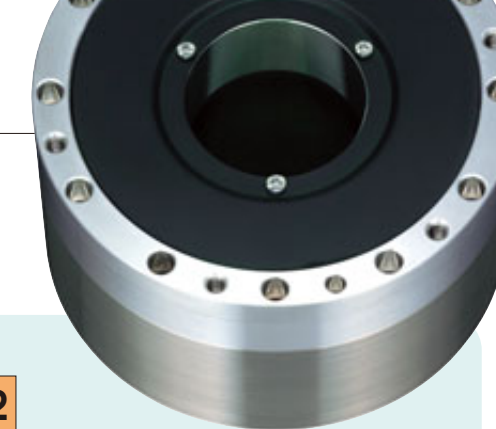
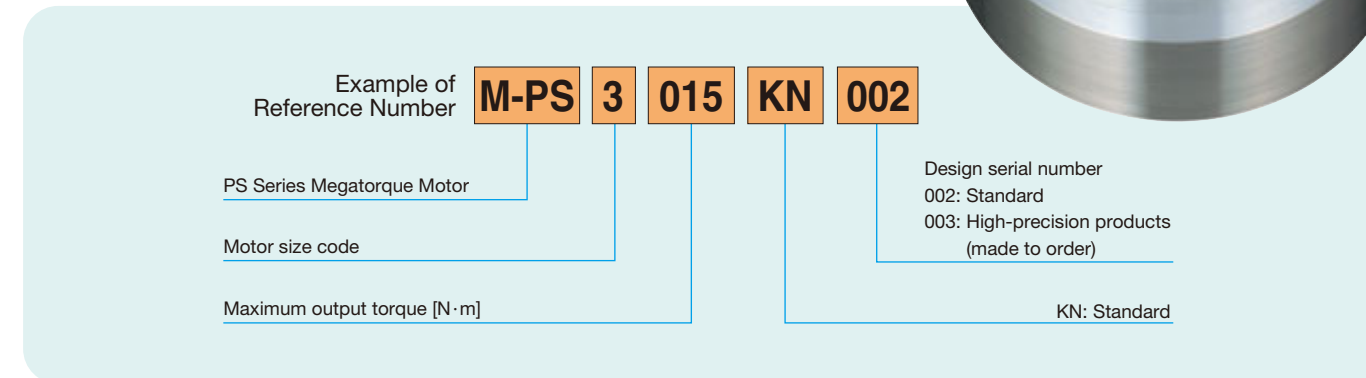

1.4 PS 3 Model Motor Specifications

Functional item	Reference number	M-PS3015KN002	M-PS3030KN002	M-PS3060KN002	M-PS3090KN002
Motor outer diameter [mm]		φ150			
Maximum output torque [N·m]		15	30	60	90
Rated output torque [N·m]		5	10	20	30
Motor height [mm]		85	102	136	170
Motor hollow diameter [mm]		φ56			
Maximum rotational speed [s ⁻¹]		10		8	5
Rated rotational speed [s ⁻¹]		5		1	1
Resolution of position sensor [counts/rev]		2 621 440			
Absolute positioning accuracy [arc sec]*1		90 (interchangeable type, ambient temperature: 25 ± 5 [°C])			
Repeatability [arc sec]		±2			
Allowable axial load [N]		2 000 (under no radial load)			
Allowable radial load [N]		1 700 (under no axial load)			
Allowable moment load [N·m]		42			
Rotor's moment of inertia [kg·m ²]		0.011	0.014	0.019	0.024
Recommended load's moment of inertia [kg·m ²]		0–1.1	0–1.4	0.12–1.9	0.12–2.4
Mass [kg]		5.5	6.9	11.0	13.8
Environmental conditions		Ambient temperature 0–40 [°C]; humidity: 20–80%; use indoors, free from dust, condensation and corrosive gas. IP30 equivalent.			

Note: Please consult with NSK in case of a simultaneous application of axial load, radial load and moment load to a Motor.

For an oscillating operation less than 45 [°], turn the Motor 90 [°] or more at least once a day.

*1: Absolute positioning accuracy of high-precision products (made to order) is 30 [arc sec]. (interchangeable type, ambient temperature of 25 ± 5 [°C]).

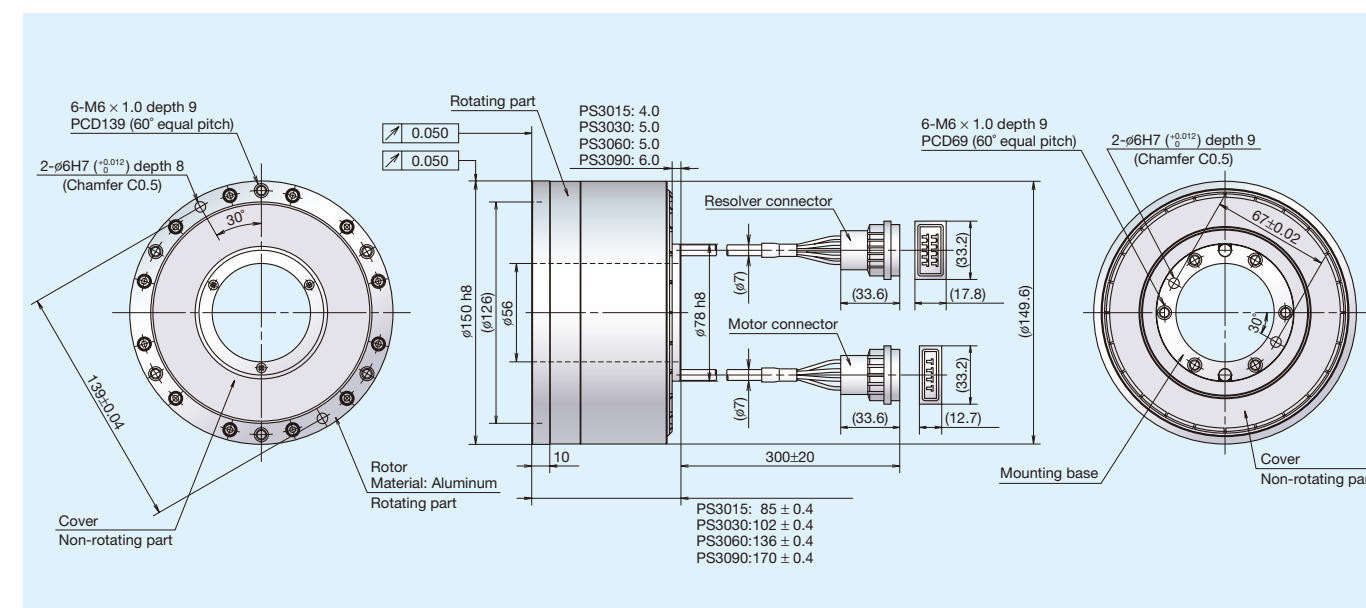

2. EDC Driver Units

1.5 Rotational Speed and Output Torque Characteristics

PS1 Model

PS1006

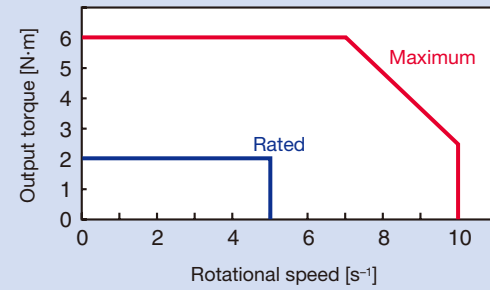

PS1012

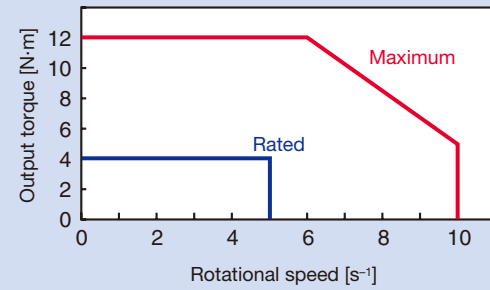

PS1018

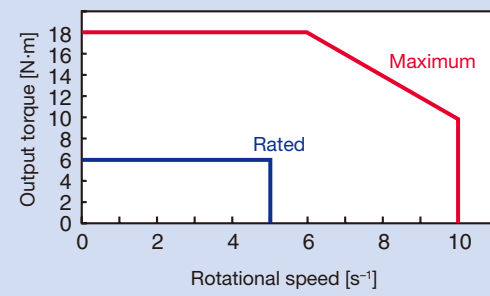

PS3 Model

PS3015

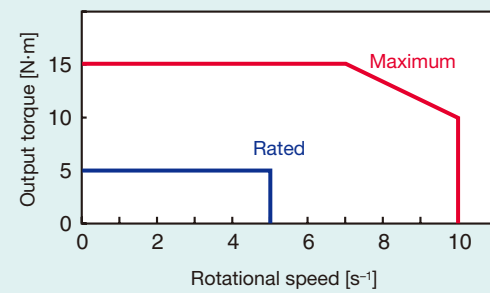

PS3030

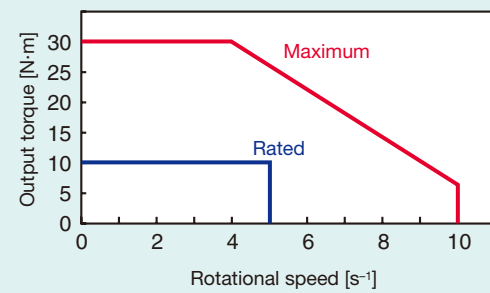

PS3060

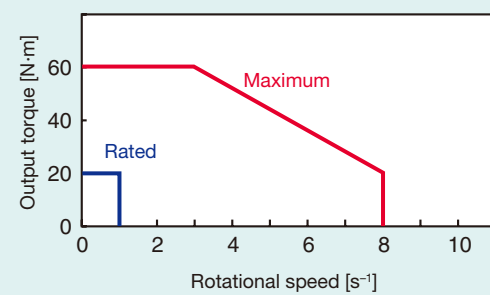

PS3090

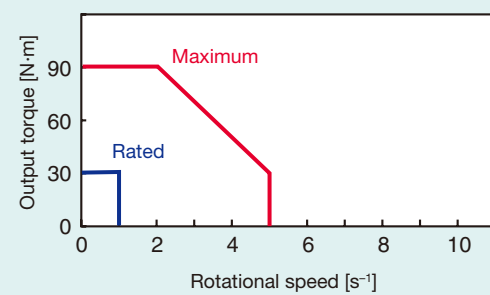

2.1 Coding for Driver Unit Reference Number

Example of Reference Number **M-EDC - PS1006 A B 5 02 -01**

EDC Driver Unit

Motor model

Main power voltage
A: 200-230 [VAC] (single-phase)
C: 100-115 [VAC] (single-phase)

Specification of position sensor
B: Incorporates absolute position sensor

No code: No accessories included
-01: Connector, Mounting bracket, User's Manual (Japanese version)
-02: Connector, Mounting bracket, User's Manual (English version)

Design serial number
02: Standard
03: High-precision products (made to order)

Function 5: Standard
C: CC-Link (made to order)

2.2 Dimensions of Driver Unit



Accessories for EDC Driver Unit

Accessories vary depending on the requested functions. For example, "5: Standard" type comes with the following:

- ① CN2 connector (user side)
Connector: 54306-5019 (Molex)
Connector shell: 54331-0501 (Molex)
- ② CN5 connector (user side)
Connector: 231-305/026-000 (WAGO)
Wiring lever: 231-131(WAGO)
- ③ Mounting bracket
- ④ User's Manual

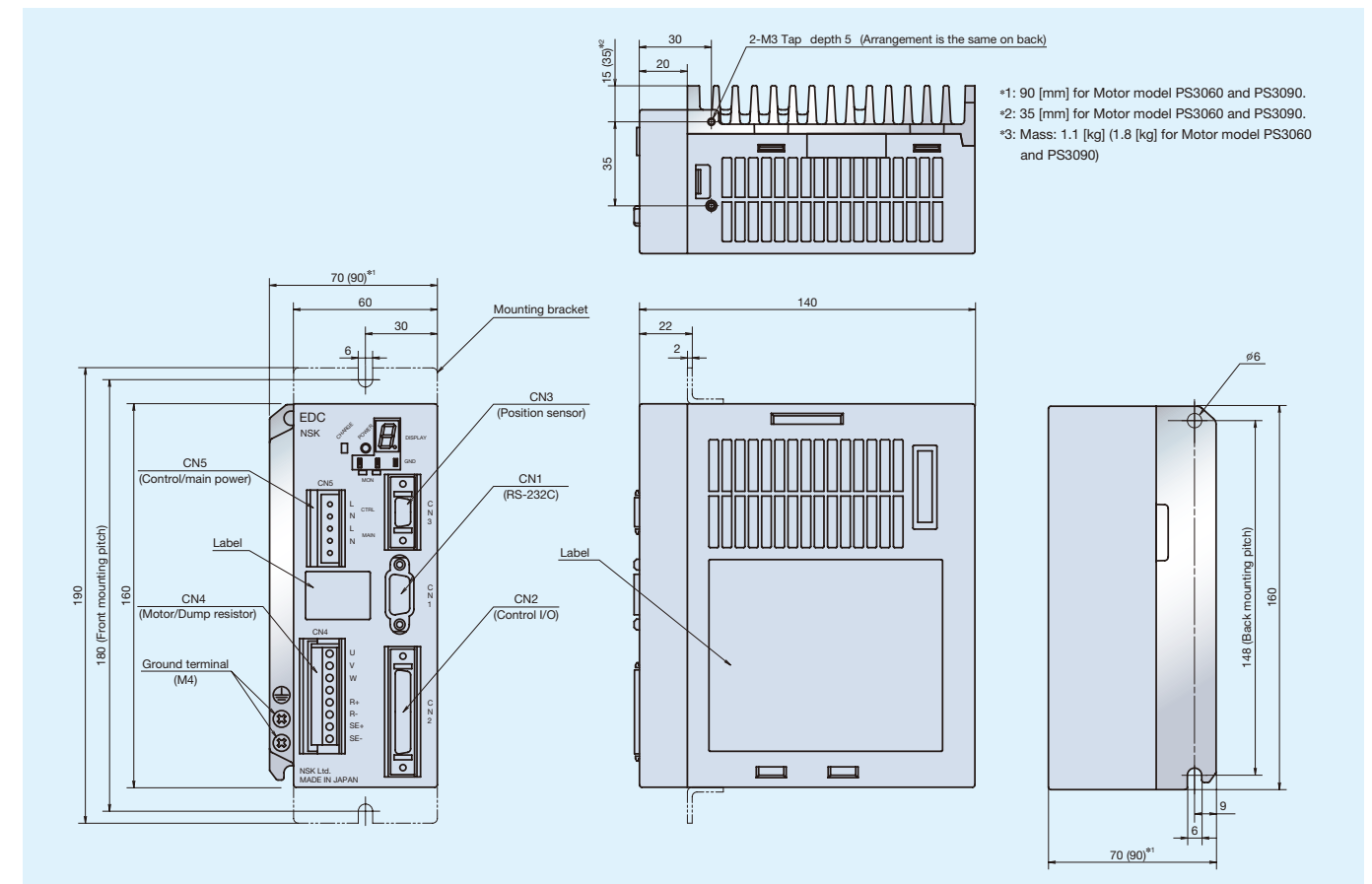

2.3 General Specifications of Driver Unit

Item	Motor model		PS1006	PS1012	PS1018	PS3015	PS3030	PS3060	PS3090
	Input power	Rated capacity [VA]		230	380	500	470	770	1 300
Maximum capacity [VA]			670	1 200	1 500	1 400	2 400	3 900	5 900
Control power source		Single phase 100–115 [VAC], single phase 200–230 [VAC]							
Main power source		Single phase 100–115 [VAC], single phase 200–230 [VAC]							
Resolution of position sensor [counts/rev]		2 621 440							
Position operation mode		Program operation (Up to 256 Program channels), Position commands and parameter settings are programmable, Pulse train command, RS-232C serial communication command, Jogging, Home Return							
Input signal	Pulse train command	Opto coupler input. Maximum frequency 1MHz Input format: CW/CCW, Pulse & direction or $\phi A/\phi B$ Resolution changer for free multiplication is available (1 000-5 242 880 [counts/rev])							
	Control input	Opto coupler input (\pm command), 17 input ports. Input voltage: 24 [VDC], Emergency stop, Alarm clear, Over travel limit + direction, Over travel limit -direction, Servo on, Program operation start, Stop, Internal program channel switching 0 to 7, Jog, Jog direction, (Hold, Velocity, integration OFF, Home Return start, and Home position limit)							
Output signal	Position feedback signal	Signal format: $\phi A/\phi B/\phi Z$ line driver. Free resolution setting to $\phi A/\phi B$ is available. Resolution of $\phi A/\phi B$: Shipping set: 20 480 [counts/rev] (Quadrupled: 81 920) Maximum: 1 310 720 [counts/rev] (Quadrupled: 5 242 880) *As the maximum frequency is 781K [Hz], the setting of the resolution limits the maximum velocity.							
	Control output	Opto coupler (\pm command), 8 outputs. Max. switching capacity: 24 [VDC] / 50 [mA] Driver Unit ready, Warning, Over travel limit direction \pm direction, Servo state, Busy, In-position, Target proximity A (Target proximity B), Zone A · B · C, Travel limit \pm , Normal, Position error under/over, Velocity under/over, Torque command under/over, Thermal loading under/over, Home return complete, Home position defined							
Alarms		RAM error, ROM error, system error, interface error, ADC error, emergency stop, CPU error, position sensor error, absolute position error, motor cable disconnect, excessive velocity, resolver excitation amplifier alarm, commutation error, overheat, main AC Line over voltage, Excess current, Control AC line under voltage, power module alarm, Excess position error, program error, automatic tuning error, Position command/feedback error, Software thermal error, Main AC Line under voltage, travel limit over. Field bus warning, home position undefined, Field bus error							
Monitors		Analog monitor x 2, (free range and offset setting), RS-232C monitor							
Communication		RS-232C serial communication (synchronous, 9 600 [bps])							
Others		Automatic tuning Function set to Input/output ports available Temporal parameter setting by program is available Individual acceleration/deceleration setting Acceleration profiling							
Field bus		CC-Link Ver. 1.10 compatible (optional)							
Environmental conditions	Operating/Storing temperatures	0 to 50 [°C] for operating / -20 to +70 [°C] for storing							
	Operating/Storing humidity	90% or less [no condensation]							
	Vibration resistance	4.9 [m/s ²]							
Internal functions	Regeneration circuit	A Dump resistor is available (External unit. M-E014DCKR1-100, or 101). Connect to R+ and R-. Never short circuit them.							
	Dynamic brake	Functions at power off, servo off and an occurrence of alarm.							
Compatible safety regulation	UL	UL508C							
	CE	LVD	EN50178						
		EMC	EMI: EN55011, EMS: EN61000-6-2						
Connector	RS-232C	CN1	D-sub 9 pins						
	Control I/O	CN2	Standard specification: Half pitch connector 50 pins (user side connector) CC-Link specification: Half pitch connector 10 pins (user side connector)						
	Position sensor	CN3	Half-pitch connector 14 pins						
	Motor	CN4	Plastic connector (UL and CE compatible)						
	Optional dump resistor								
	Main/control power source	CN5	Plastic connector (UL and CE compatible) (user side connector)						
	CC-Link (option)	CN6	Connector MSTB2, 5/5-STF-5, 08 AU (Phoenix Contact)						
Mass [kg]	Standard	1.1				1.8			
	CC-Link	1.3				2.0			

2.4 Signal Specifications of CN2 (Control I/O)

Input Output	Signal Code	Pin No.	Signal Name	Function
Input signal	DC24	1, 2	24 [VDC] external power supply	External power supply for input signal
	EMST	3	Emergency stop	Terminates positioning operation and the Motor stops by the dynamic brake.
	ACLR	4	Alarm clear	Clears warning.*1
	OTP	5	Over travel limit, +direction	IF OTP goes active, the Motor servo is locked in the CW direction.*1
	OTM	6	Over travel limit, -direction	IF OTM goes active, the Motor servo is locked in the CCW direction.*1
	SVON	7	Servo on	If SVON goes active, the servo turns on and the system waits for a command to be entered.*1
	RUN	8	Start program	Starts program operation specified by the PRG input.*1
	STP	9	Stop	Stops positioning operation and execution of the program.*1
	—	10	(Do not connect.)	—
	PRG0	11	Internal program channel selection 0	For a program positioning operation: A combination of ON and OFF of PRG0 to PRG7 inputs specifies a channel (0-255) to be executed.
	PRG1	12	Internal program channel selection 1	
	PRG2	13	Internal program channel selection 2	
	PRG3	14	Internal program channel selection 3	
	PRG4	15	Internal program channel selection 4	
	PRG5	16	Internal program channel selection 5	
	PRG6	17	Internal program channel selection 6	
	PRG7	18	Internal program channel selection 7	
	JOG	19	Jogging	If JOG goes active, the Motor rotates. If it goes inactive, the Motor decelerates and stops.*1
	DIR	20	Jogging direction	Specifies the direction of jogging.
	—	21	(Do not connect.)	—
	CWP+	22	CW pulse train (+)	Pulse train command rotates the Motor in the CW direction.
	CWP-	23	CW pulse train (-)	
CCWP+	24	CCW pulse train (+)	Pulse train command rotates the Motor in the CCW direction.	
CCWP-	25	CCW pulse train (-)		
Output signal	COM	26, 27	Output signal common	Common for output signal
	DRDY	28	Driver Unit ready	Reports that the Motor is ready to rotate. (The port opens when the Motor is not ready or an alarm occurs.)
	WRN	29	Warning	Warns abnormality in the System.*2
	OTPA	30	Over travel limit (+direction) detected	Reports the output of over travel limit (software and hardware) in the plus direction.*2
	OTMA	31	Over travel limit (-direction) detected	Reports the output of over travel limit (software and hardware) in the minus direction.*2
	SVST	32	Servo state	Reports states of servo.*2
	BUSY	33	In-operation	Reports state of positioning operation.*2
	IPOS	34	In-position	Reports the condition of positioning error and the positioning operation.*2
	NEARA	35	Target proximity A	A pulse signal that reports the number of rotations of Motors. Free setting output resolution in $\phi A/\phi B$ is available. Output format is line driver.
	CHA	36	Positioning feedback signal ϕA	
	*CHA	37	Positioning feedback signal * ϕA	
	CHB	38	Positioning feedback signal ϕB	
	*CHB	39	Positioning feedback signal * ϕB	
	CHZ	40	Positioning feedback signal ϕZ	
*CHZ	41	Positioning feedback signal * ϕZ		
—	42	(Do not connect.)	—	
SGND	43	Signal ground	Ground for the position feedback signal	
—	44–50	(Do not connect.)	—	

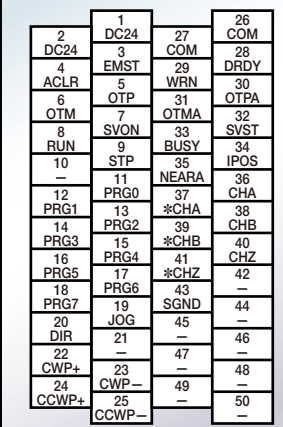

Selection and optional setting of control Input/Output signal functions

• You may set signal functions of control Input/Output to any port by the parameters.

*1. Input signal

- Select necessary 16 input signals out of the 22 input signals listed above and then set them to the Pin numbers 4 to 9 and 11 to 20. (In addition to the Input signals listed above, you may select any of the following signals: Hold, Velocity override, Integration OFF, Home return start, and Home position limit.)
- Pin No. 3 is fixed to the "Emergency stop" signal. (The signal polarity is variable.)

*2. Output signal

- Select necessary 7 output signals out of the 23 output signals listed in the above table and then set them to the Pin numbers 29 to 35. In addition to the Output signals listed above, you may select any of the following signals: Target proximity B, Zone A/B/C, Travel limit direction (\pm), Normal, Position error (under/over), Velocity (under/over), Torque command (under/over), Thermal loading (under/over), Home return completed, and Home position defined.
- The output "Driver Unit ready" set to Pin No. 28 can only be replaced with the output signal "Normal." (Signal polarity cannot be changed.)

3. Option

3.1 CC-Link

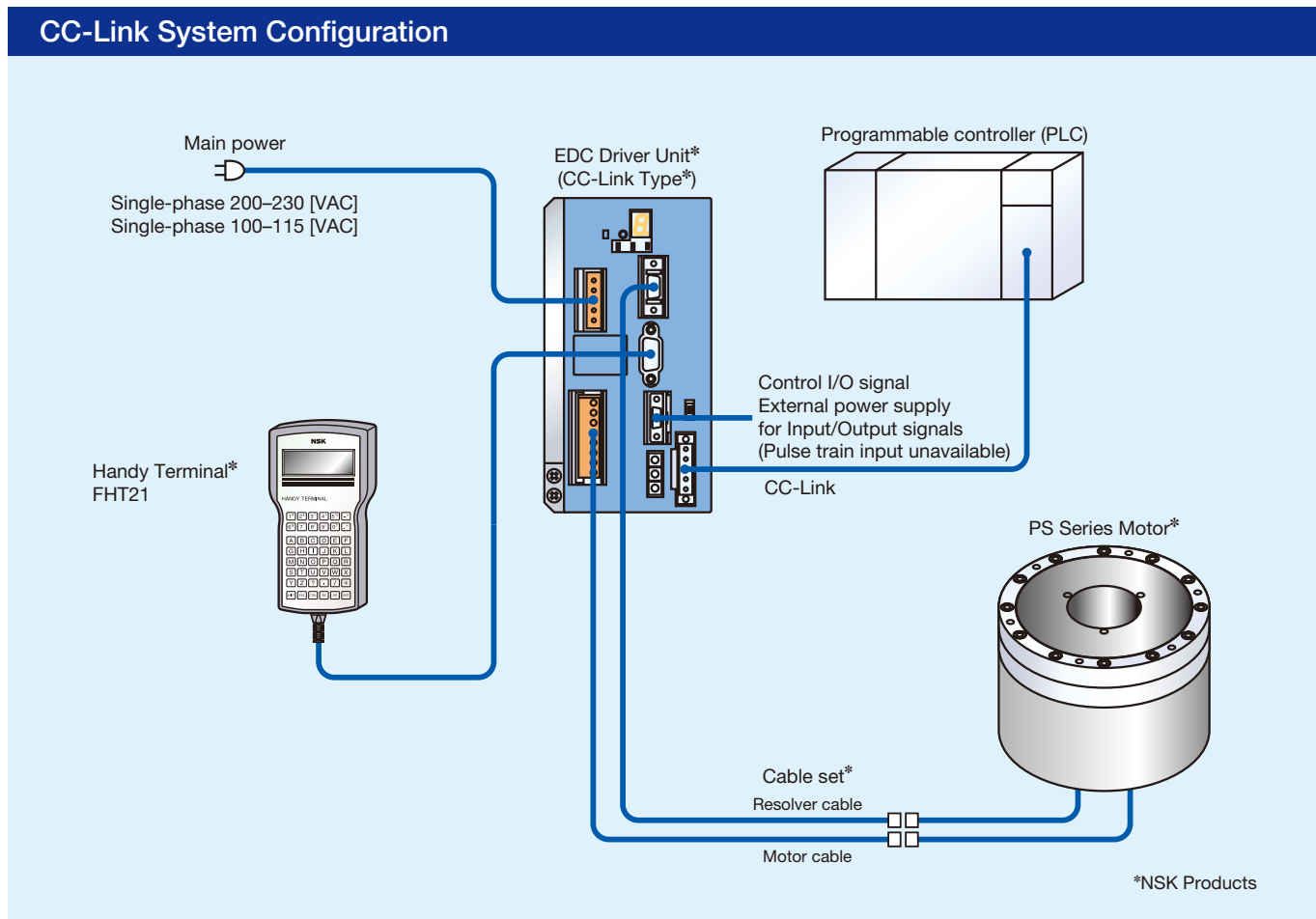

- The EDC Driver Unit provides the field bus (CC-Link) compatibility.
- The station numbers and the baud rate can be set by switches on the Driver Unit's front panel.
- Monitoring communication status by LED, and terminating resistor can be switched on/off.
- The EDC Driver Units are fully compatible with CC-Link Ver. 1.10.

3.2 Dimensions of EDC Driver Unit (CC-Link Type)

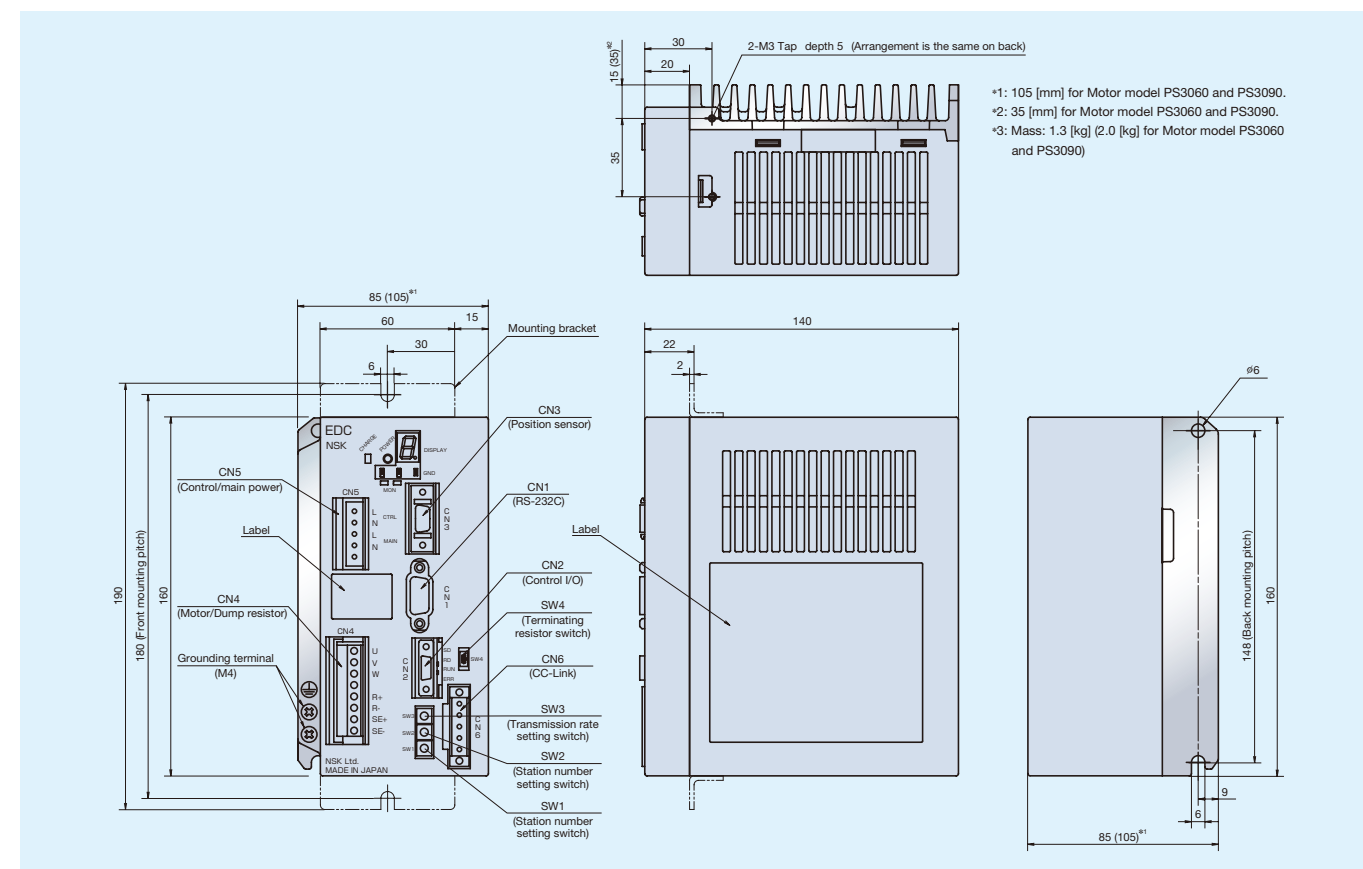

Accessories for EDC Driver Unit (CC-Link Type)

Accessories vary depending on the functions. For example, Accessories of "C: CC-Link" Driver Unit are as follows.

- | | | |
|--|--|--|
| ① CN2 connector (user side)
Connector: DHF-PDA10-3-A01 (DDK) | ③ CN6 connector (user side)
Connector: MSTB, 5/5-STF-5, 08AU
(Phoenix contact) | ⑤ User's Manual (English version) |
| ② CN5 connector (user side)
Connector: 231-305/026-000 (WAGO)
Wiring lever: 231-131 (WAGO) | ④ Mounting bracket | ⑥ User's Manual for CC-Link
(English version) |

Cable with CN2 connector (sold separately)
Reference number: M-E011DCCN1-001

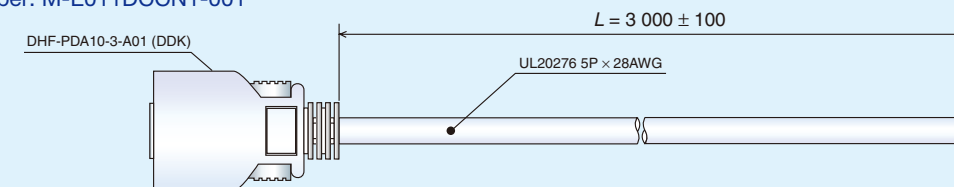

3.3 I/O Signal Specifications of CN2 (CC-Link Type)

Input/Output	Signal Code	Pin No.	Signal Name	Function
Input signal	DC24	1	24 [VDC] external power supply	External power supply for input signal
	—	2	(Do not connect.)	—
	EMST	3	Emergency stop	Terminates positioning operation and the Motor stops by the dynamic brake.
	ACLR	4	Clear warning	Clear warning.
	OTP	5	Over travel limit, + direction	If OTP goes active, the Motor servo is locked in the CW direction.
	OTM	6	Over travel limit, - direction	If OTM goes active, the Motor servo is locked in the CCW direction.
Output signal	—	7	(Do not connect.)	—
	DRDY	8	Driver Unit ready	Reports that the Motor is ready to rotate. (Those pins are open when the Motor is not ready or an alarm occurs.)
	—	9	(Do not connect.)	—
	COM	10	Output signal common	Common for output signal

1	6
DC24V	OTM
2	7
3	8
EMST	DRDY
4	9
ACLR	10
5	COM

Pin-out

4. Selection of PS Series Motors

3.4 Cable Set

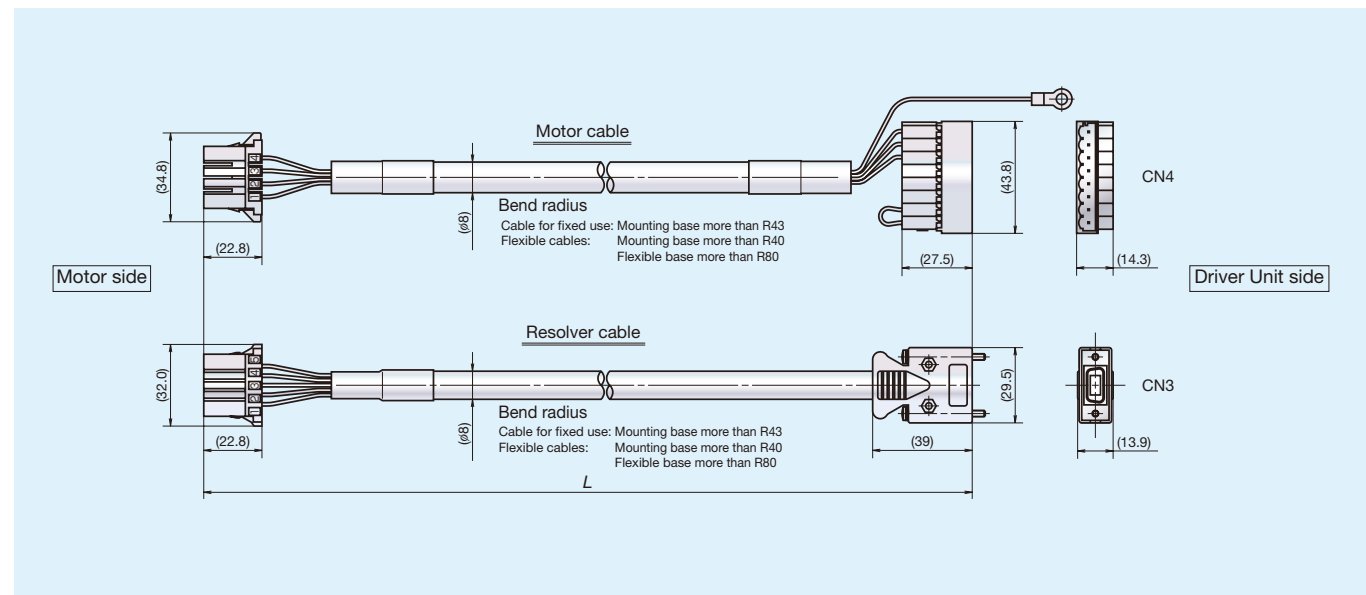
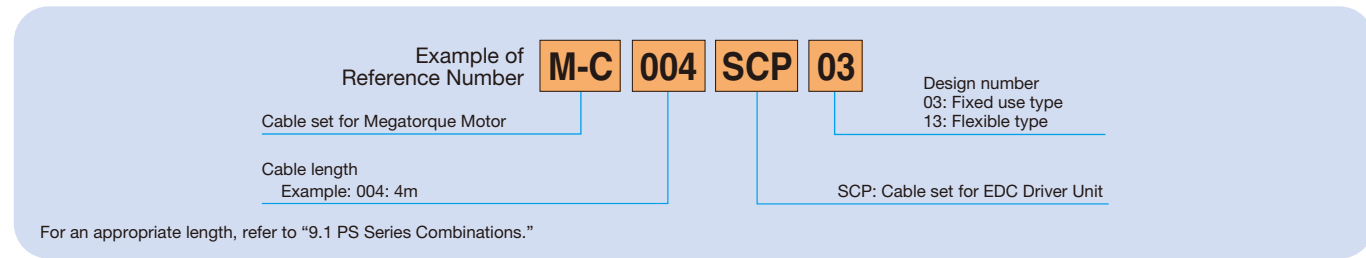

Cable bend radius (for both motor cable and resolver cable)

	Bend radius at fixed side	Bend radius at moving side
Fixed use type	R43 or more	—
Flexible type	R40 or more	R80 or more

3.5 Handy Terminal

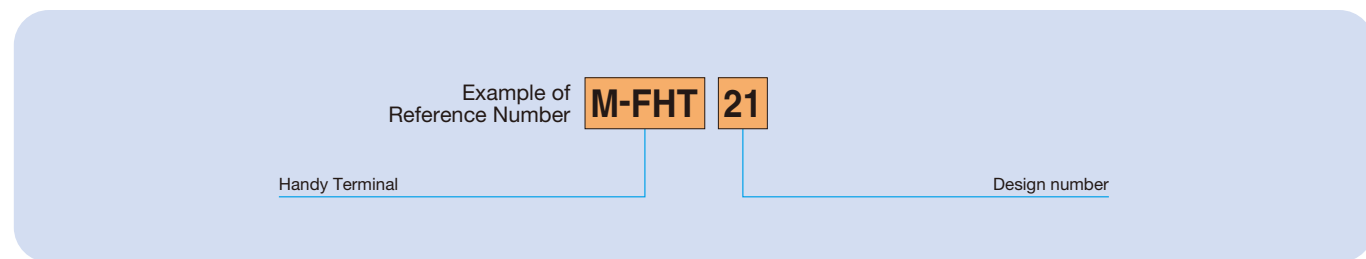

Handy Terminal FHT21 is an easy-to-handle RS-232C communication terminal for inputting parameters and programs to the EDC Driver Unit.

- LCD screen: 20 letters × 4 lines, no external power source required, cable length: 3 [m]

Conventional models M-FHT01 and M-FHT11 are also supported by the EDC Driver Unit.



To select appropriate Megatorque Motors, examine the following data.

- 4.1 Loads on the Motor (① Moment of inertia of the load, ② Axial load, radial load, moment load; ③ Holding torque required during halts)
- 4.2 Positioning Accuracy
- 4.3 Positioning Time (Index Time)
- 4.4 Selection of Dump resistor
- 4.5 Effective Torque Calculations

4.1 Loads on the Motor

- (① Moment of inertia of the load; ② Axial load, radial load, moment load; ③ Holding torque required during halt)
- ① **Load moment of inertia J**
When the Megatorque Motor System is used, the size of the moment of inertia of the load mounted to the Motor rotor will significantly affect the acceleration/deceleration characteristics. Thus, calculation of the moment of inertia of the load J is required.
- ② **Axial load, radial load, moment load**
Calculate the load on the Motor. The relationship between external force and load is represented in the following three patterns. Ensure the axial load/radial load and the moment load are set within the limiting axial, radial and limiting moment loads. (Refer to the limiting values listed in "1. Motor Specifications for PS Series Motor" on pages 5–6 of this catalog.)

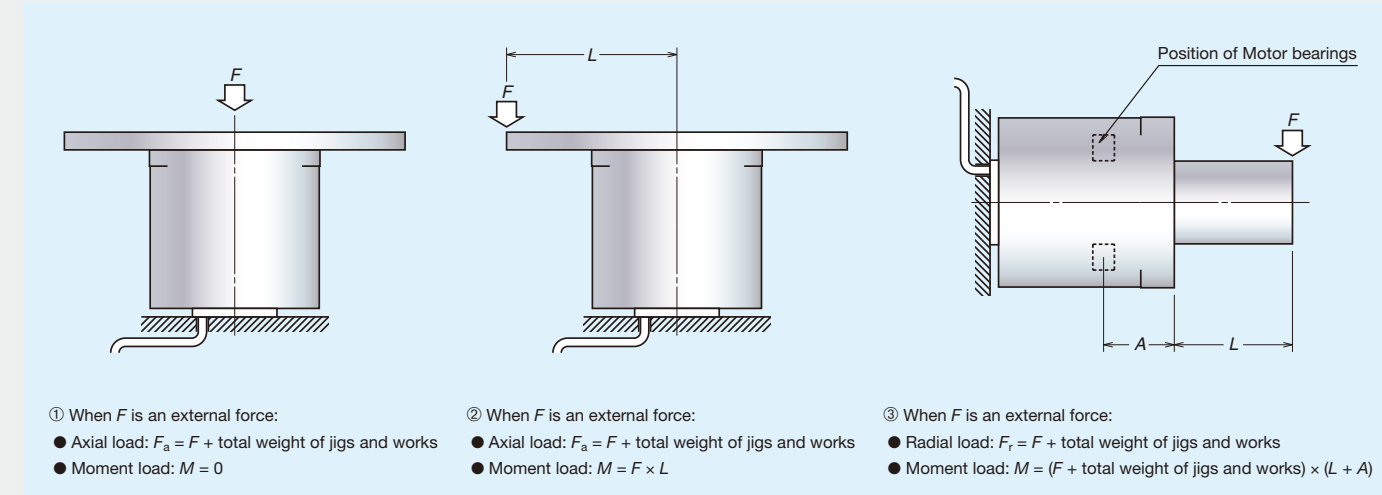

Motor Model	PS1006 PS1012 PS1018	PS3015 PS3030 PS3060 PS3090
Dimension A [mm]	30.2	32.9

③ **Holding torque required during halt**
When the arm is halted at the following position, the torque, equal to $F \times L$, will be applied on the Motor as a load torque. Therefore, the rated torque of the Motor, equal to or greater than the load torque, is required.

4.2 Positioning Accuracy

- The positioning accuracy of the Megatorque Motor System is considered by two respects as follows:
- ① Absolute positioning accuracy: 90 [arc sec] (Interchangeable)
 - ② Repeatability: ± 2 [arc sec]

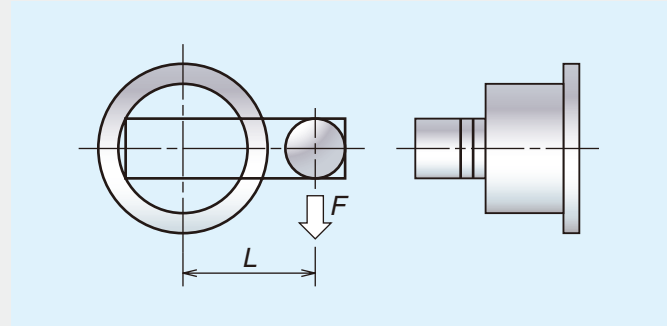

[Example 1]

We examine the compatibility of the PS Series Motors, assuming a required repeatability of ±0.02 [mm] at 300 [mm] distance from the center.

From $\tan \theta = 0.02 \div 300$
 $\theta = \tan^{-1}(0.02 \div 300)$
 $= 3.8 \times 10^{-3} [^\circ]$
 $= 14 [\text{arc sec}]$

Therefore, ±14 > ±2.

Both PS1 and PS3 Models can be used in terms of the positioning accuracy.

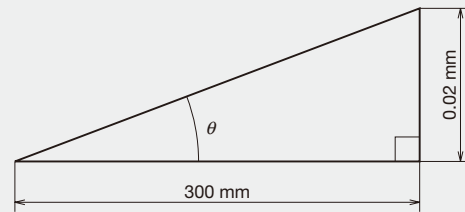

4.3 Positioning Time (Index Time)

When a Megatorque Motor is used to index an angle, index times can be roughly calculated as follows.

- J_m : Load moment of inertia [kg · m²]
- J_r : Rotor moment of inertia [kg · m²]
- N : Rotational speed of the Motor [s⁻¹]
- T : Output torque at the rotational speed N [N · m]
- T_m : Load torque [N · m]
- t_1 : Travel time [s]
- t_2 : Settling time [s]
- t_3 : Positioning time [s]
- Δt : Accelerating/decelerating time [s]
- θ : Rotational angle [°]
- η : Safety coefficient (normally 1.5)

In accordance with the list above,

$$\Delta t = \frac{(J_m + J_r) \times 2\pi N}{(T - T_m)} \times \eta$$

$$t_1 = \frac{\theta}{360 \times N} + \Delta t$$

$$t_3 = t_1 + t_2$$

Where $T - T_m > 0$, and $2 \times \Delta t \leq t_1$

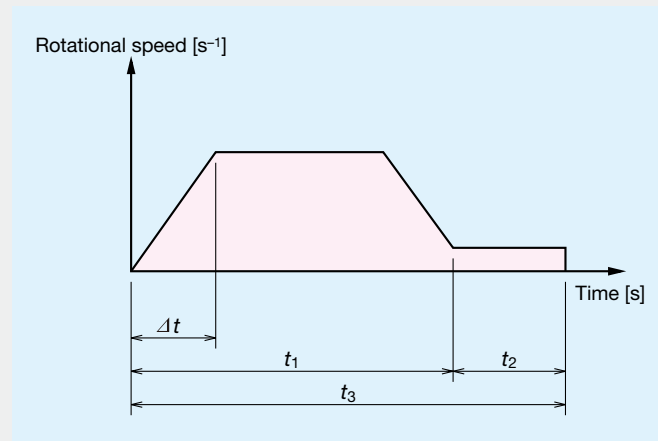

Please refer to the following table for the settling time. Since the settling time will also be affected by factors such as the magnitude of the moment of inertia of the load and rigidity of the whole structure, the settling time is not absolute.

Required repeatability [arc sec]	Settling time t_2 [s]
±2 to ±10	0.1
±10 to ±100	0.04
±100 and above	0.001

4.4 Selection of Dump Resistor

① The rotational energy of a Megatorque Motor during deceleration is obtained.

Calculate the rotational energy using the following equation:

Rotational energy = $1/2 \times J \times \omega^2$ [J] J_r : Rotor's moment of inertia [kg·m²]
 $= 1/2 \times J \times (2\pi N)^2$ [J] J_m : Moment of inertia of the load [kg·m²]
 $J = J_r + J_m$ N : Rotational speed [s⁻¹]

② Regenerative energy capacity by the internal capacitors

The regeneration energy that can be charged of by the internal capacitors is 28 [J] (200 [VAC]).

③ Calculate energy consumed by Dump resistor:

Energy consumed by Dump resistor [J] = Rotational energy [J] - 28 [J] capacitor absorption energy.

When the difference is zero or less, no Dump resistor is necessary.

When the difference is greater than zero, use the following procedure to obtain the required capacity for a Dump resistor.

④ Calculate required capacity for a Dump resistor:

Required capacity for a Dump resistor [W] = Energy consumed by Dump resistor [J] / (Operation cycle [s] × 0.25).

0.25: Load ratio of Dump resistor use

When the quotient is 1.75 or less, use Dump resistor: M-E014DCKR1-100. (optional)

When the quotient is 30 or less, use Dump resistor: M-E014DCKR1-101. (optional)

4.5 Effective Torque Calculations

When selecting a PS Series Motor, it is necessary to consider the maximum required torque and the effective torque required for the actual operation.

Here, we examine a motor that can rotate 90° in 0.2 [s], assuming that the load moment of inertia is 0.05 [kg · m²]. We will also calculate the effective torque when a standard operation cycle is 0.6 [s].

- Conditions: Maximum rotational speed = 2.5 [s⁻¹]
- Rotational acceleration = 25 [s⁻²]
- Repeatability = ± 2 arc sec
- Dwell time = 0.09 [s]
- J_m (load moment of inertia) = 0.05 [kg · m²]
- J_r (moment of inertia of the rotor) = 0.019 [kg · m²] (for PS3060)

• Since the rotational acceleration is 25 [s⁻²], we calculate the approximate required torque using the following equation.

Required torque* = (load moment of inertia + moment of inertia of the rotor) × angular acceleration
 $= (0.05 + 0.019) \times 2\pi \times 25$
 $= 10.8$ [N · m]

Therefore, the candidate selection is a motor with a maximum output torque of 10.8 [N · m] or larger.

The PS1 Model (excluding PS1006) or PS3 Model can be selected.

*Since the moment of inertia of the rotor of the motor varies depending on the motor, the required torque needs to be recalculated for each motor.

• The effective torque required for the actual operational pattern in use (see the following diagram) needs to be examined. Here, we will determine whether the PS3060 meets the operational conditions.

Equations: $T1$: Torque at accelerating [N · m] α : Rotational acceleration [s⁻²] = 25 [s⁻²]
 $T2$: Dynamic friction torque [N · m] η : Safety coefficient = 1.3 Dynamic friction torque [N · m]

PS1 Model	PS3 Model
0.7	2.0

$T3$: Torque at decelerating [N · m]
 J_m : (Load moment of inertia) = 0.05 [kg · m²]
 J_r : (Rotor moment of inertia) = 0.019 [kg · m²]

Torque at accelerating $T1 = \eta (J_m + J_r) \times \alpha + T2 = 1.3 \times (0.05 + 0.019) \times 2\pi \times 25 + 2.0 = 16.1$ [N · m]

Torque at decelerating $T3 = \eta (J_m + J_r) \times \alpha - T2 = 1.3 \times (0.05 + 0.019) \times 2\pi \times 25 - 2.0 = 12.1$ [N · m]

t_1 = accelerating/decelerating time = 0.1 [s], t_2 = settling time = 0.01 [s],

t_3 = dwell time = 0.09 [s], t_4 = cycle time $t_1 \times 4 + t_2 \times 2 + t_3 \times 2 = 0.6$ [s]

$$\text{Effective torque} = \sqrt{\frac{\{(T1)^2 \times t_1 + (T3)^2 \times t_1\} \times 2}{t_4}} = 11.6$$
 [N · m]

Rotational energy = $1/2 \times J \times (2\pi N)^2 = 1/2 \times (0.05 + 0.019) \times (2\pi \times 2.5)^2 = 8.5$ [J]

The effective torque is 11.6 [N · m], which is less than the PS3060's rated output torque of 20 [N · m].

Therefore, the PS3060 sufficiently meets the operational conditions. External regenerative resistance is not necessary.

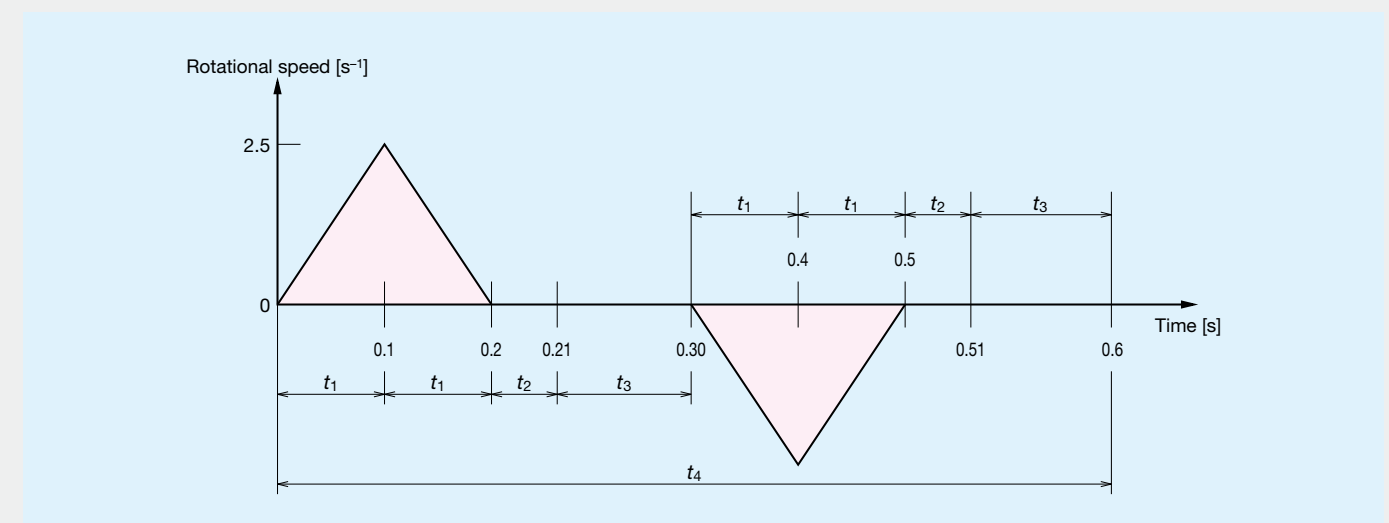

5. Installation

5.1 Installation of Motor

- Install and secure the Motor on a solid base, otherwise mechanical vibrations will be produced.
- Attach the Motor on the base using the tapped mounting holes on the underside of the Motor.
- The mounting surface should be level within 0.02 [mm].
- The Motor can be attached either horizontally or vertically.
- Take care not to push up the underside cover when attaching the motor.
- Do not use the leads of a motor cable or a resolver cable where cables are moving. The bend radius of leads should be at least R30 [mm].

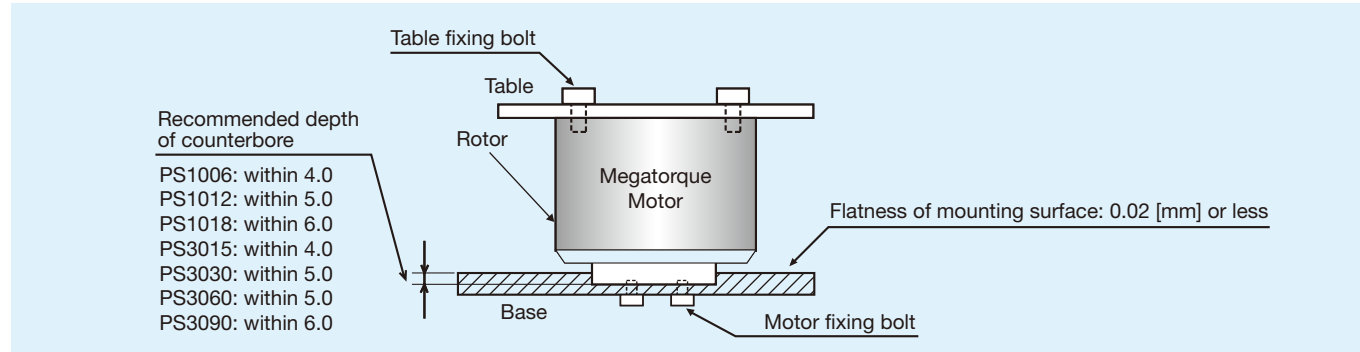

Note: If a Motor is installed as indicated in the figure below, mechanical vibrations will be produced and the velocity loop proportional gain (VG) of the Motor cannot be improved. Therefore, the ability to secure the Motor at a stop position is weakened, resulting in overshoot. Since smooth motor operation cannot be expected under this configuration, the following countermeasures must be taken.

- Directly mount load on the motor rotor (or add dummy inertia).
- Directly mount Motor on the base.

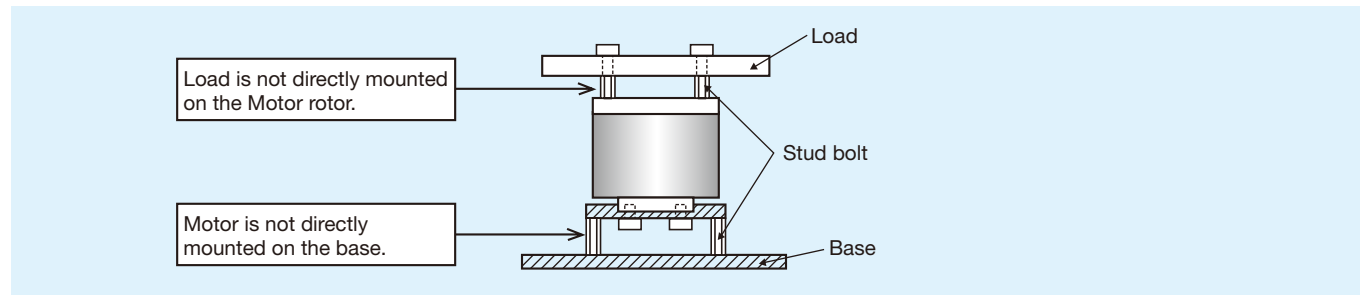

5.2 Installation of Driver Unit

- Make sure that EDC Driver Unit is installed in a vertical position. EDC Driver Unit is naturally air cooled, so the fin should be in a vertical position.
- Ambient temperatures should be in a range from 0 to 50 [°C]. EDC Driver Unit cannot be used in excess of 50 [°C]. A sufficient space of at least 100 [mm] should be provided both above and below the Driver Unit in a control cabinet.
- Operate the Driver Unit in an environment in which internally generated heat can be dissipated. If heat is trapped above the Driver Unit, open the space above the Driver Unit to permit the heat to dissipate (in this case, also take steps to prevent the entry of dust) or provide a forced-air cooling system.
- Use EDC Driver Unit in control cabinet with IP54 or higher. Protect the Driver Unit from exposure to oil mist, cutting water, cutting dust, coating gas, etc., to prevent their entry into the Driver Unit through ventilation openings, which may cause circuit failure.
- When two or more Driver Units are arranged in a row, as in the case of multi-axis combinations, adjacent driver units must be separated by a space of at least 10 [mm].
- EDC Driver Unit can be attached to a panel using front mounting brackets (optional).
- The EDC Driver Unit draws a maximum of 55 [W].

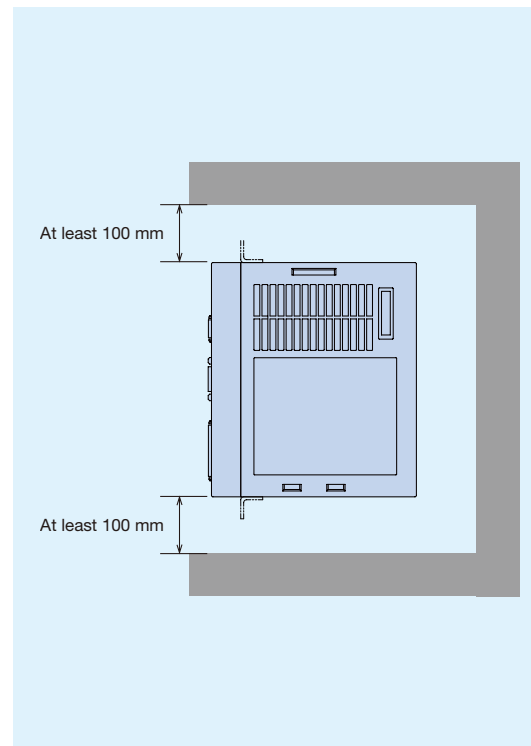

6. Dump Resistor (M-E014DCKR1-100·101)

6.1 Dimensions and Schematics

M-E014DCKR1-100

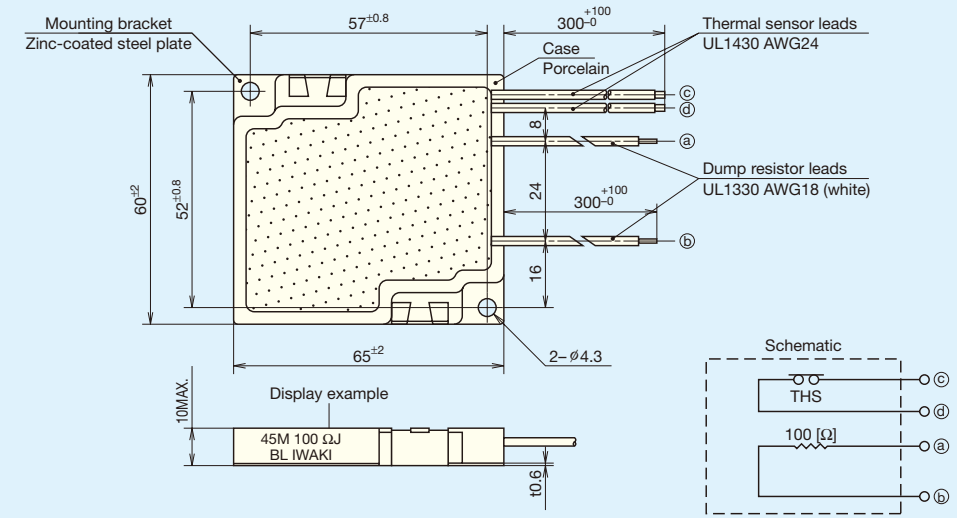

M-E014DCKR1-101

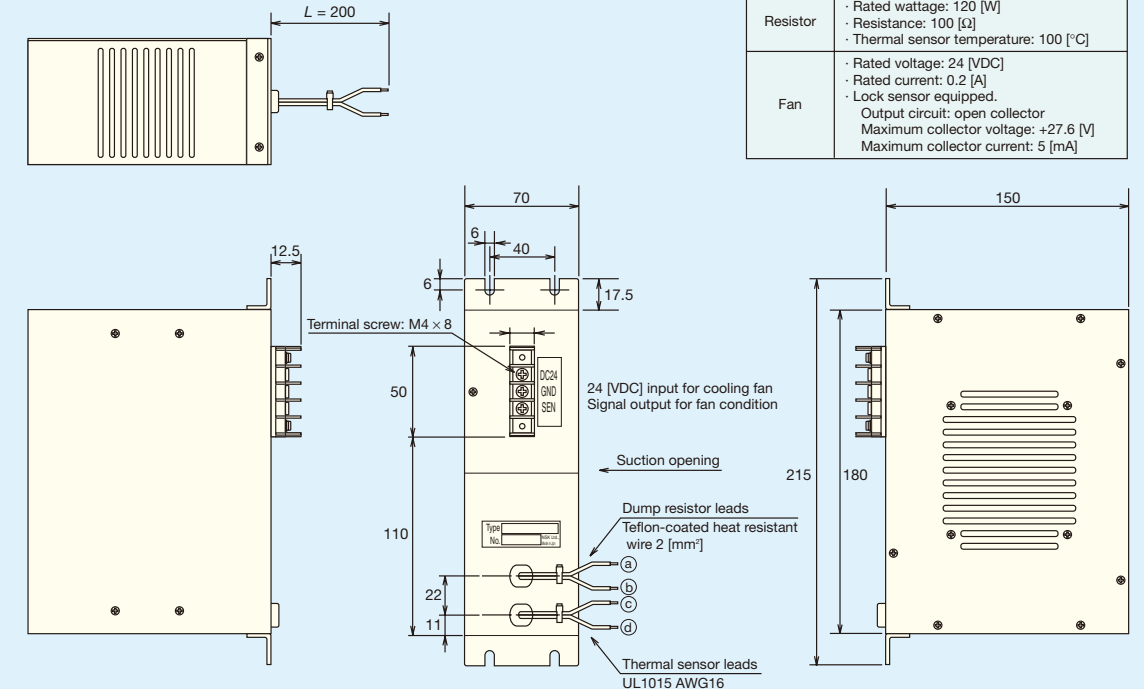

6.2 Connection to EDC Driver Unit

M-E014DCKR1-100

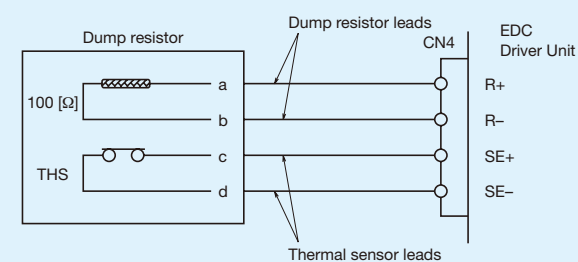

M-E014DCKR1-101

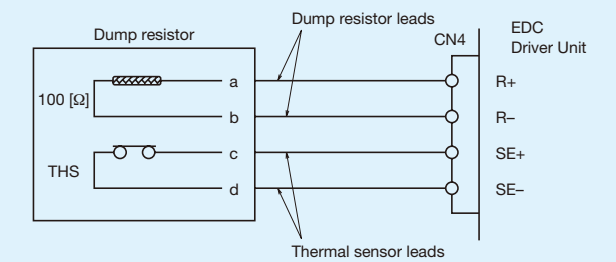

7. "EDC Megaterm" Application Software

Once installed into your personal computer, this software allows the editing, preparation and control of EDC Driver Unit programs and parameters. The software also facilitates the allocation and monitoring of control input/output. Its oscilloscope function permits Motor operation to be easily confirmed.

EDC Megaterm can be obtained as a free download from the NSK Web site.
 (http://www.jp.nsk.com/tech-support/seiki/appli/003_medc.html) (in Japanese)

RS-232C communication cable is available (option).
 Type: M-C003RS03 (cable length: 3 [m])

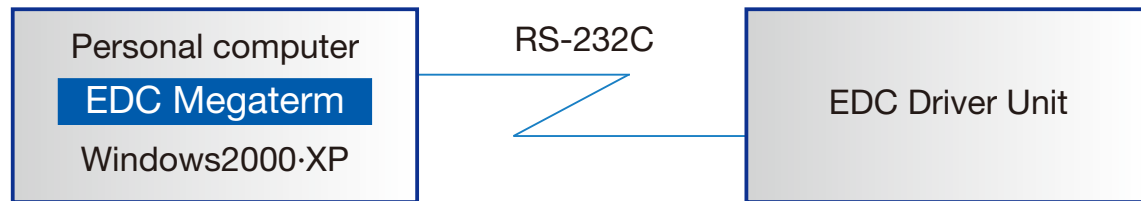

Functions

- Oscilloscope function
- Allocation and monitoring of control input/output
- Parameter edits
- Channel edits
- Others:
 - Upload/download parameter and channel data
 - Terminal



Main functions

1. Oscilloscope function

- 4-channel oscilloscope, 10 [k sampling/s] maximum
- Anything that can be monitored using the handy terminal can be displayed on the oscilloscope.
- Monitor scale is adjustable.
- Measured waveforms are output as bitmaps or CSV format.

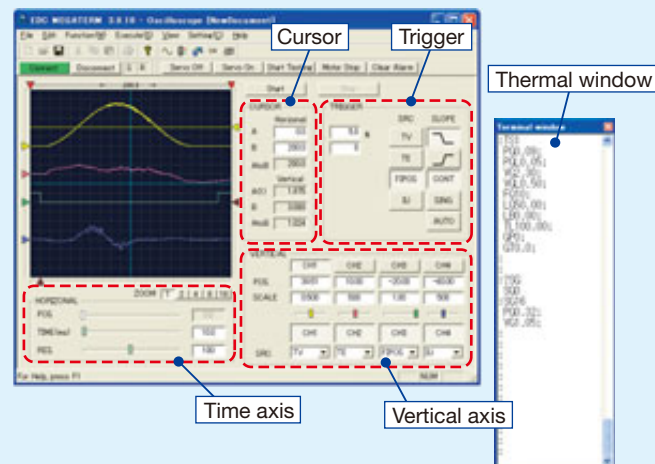

2. Allocation and monitoring of control input/output

- Allocation of control input/output by drag-and-drop editing
- Monitoring of input/output signals
- Output of allocation lists

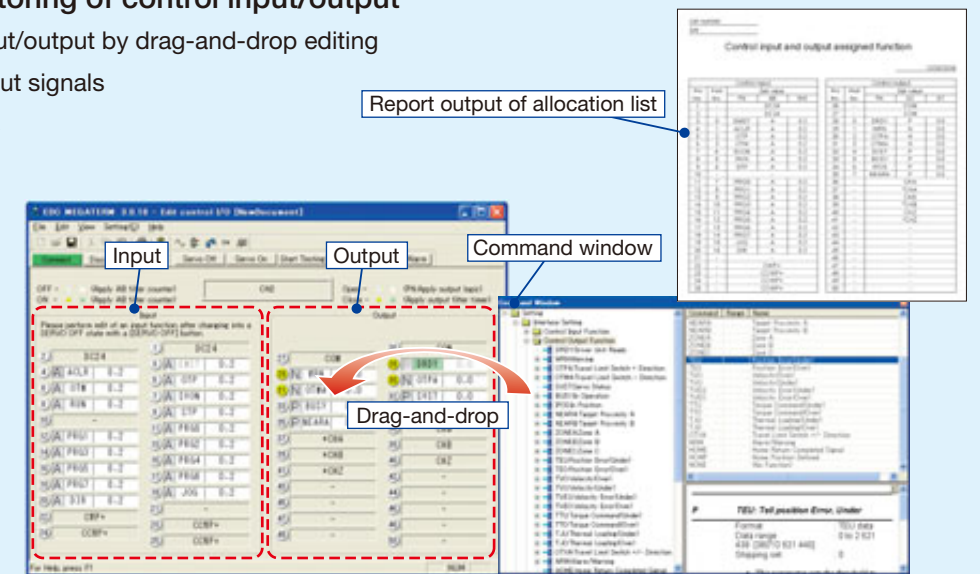

3. Parameter edits

- Parameter edits take effect in real time (Off-line editing is supported)
- Parameter-by-parameter reset to default
- Help function for parameters
- Report of parameter setting

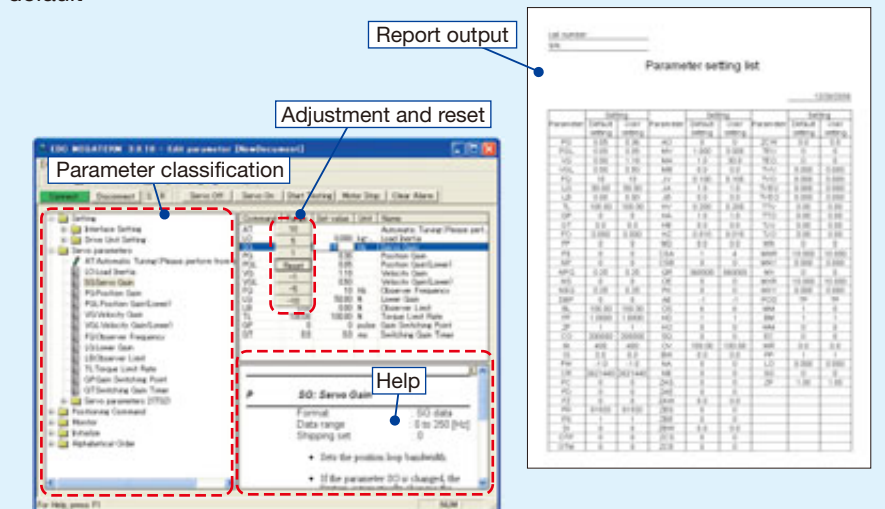

4. Channel edits

- Drag-and-drop edits from command window
- Direct input capability also supported (automatic insertion of comments)
- Report of program list

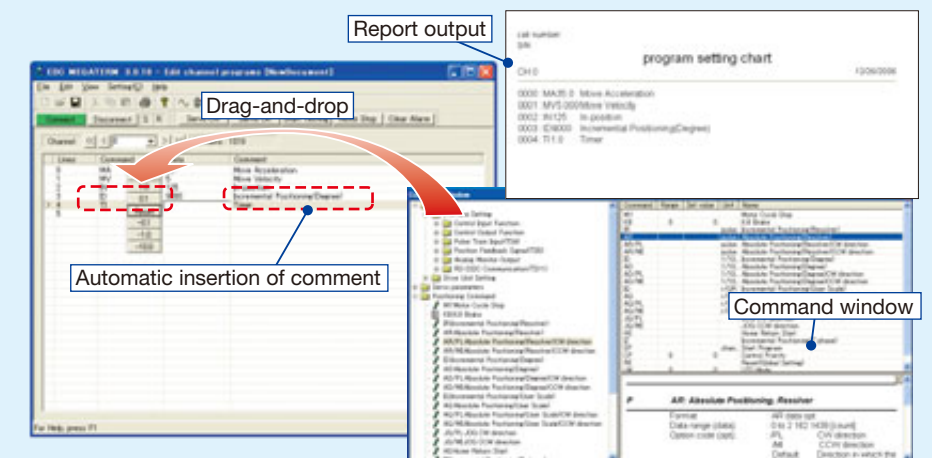

8. International Safety Standards and Warranty Information

CE Marking

- **Low voltage command (applicable standard: EN50178)**

The Megatorque Motor PS Series are incorporated into machinery as components. NSK set low voltage standards to ensure the Megatorque Motor PS Series fully comply with the EC Directive. The standards have been certified by TÜV, a third-party testing and certification organization.

- **EMC command (applicable standards: EMI EN55011 and EMS EN61000-6-2)**

NSK defined installation models (conditions) for Megatorque Motor PS Series, including installation space and wiring between Driver Units and Motors, and set EMC command standards based on 4 [m] cable models, which have been certified by TÜV, a third-party testing and certification organization.

When Megatorque Motor PS Series are incorporated into machinery, real-world installation and/or wiring conditions may differ from those of established models. Therefore, it is necessary to check for EMC command compliance (especially radiation and conduction noise) in the machinery incorporating the PS Series Motors.

Compliance with UL Standards

- **Motor**

Compliant with UL1004 (File No.: E216970)

- **Driver Unit**

Compliant with UL508C (File No.: E216221)

- **Cable set**

UL-compliant cables are used

Warranty Period

- The warranty period is either one year from delivery or 2 400 hours of operation, whichever comes first.

Limited Warranty

- The warranty is limited to the products supplied by NSK Ltd.
- The defective products will be repaired free of charge within the applicable warranty period.
- Repairs after the expiration of the applicable warranty period will be subject to payment.

Exemption Clause

- The warranty will not apply to any of the following cases:
 - Failure due to work and operation performed not in accordance with the instruction manual designated by the supplier
 - Failure due to improper handling, misuse, modification or careless operation performed by the user
 - Failure resulting from causes not attributable to the supplier
 - Failure caused by modification or repair made by anyone other than the supplier
 - Failure resulting from causes beyond the reasonable control of the supplier, including natural disasters or other accidents
- The warranty is limited to delivered units and the supplier shall not be liable for any incidental or consequential damage which may be caused by the failure of delivered units.

Services Charges

- Prices of goods do not include any applicable service charges, such as the dispatching of engineers.
- Startup or maintenance services that require the dispatching of engineers are subject to payment even during the applicable warranty period.
- Service charges will be invoiced in accordance with the supplier's standard service charge list.

Announcement of production discontinuation and maintenance service period after discontinuation

- Production discontinuation will be announced one year in advance. Announcement will be released by the supplier or appear on the NSK Web site. The maintenance service period is five (5) years after production discontinuation.

9. Combinations

9.1 PS Series Combinations

Motor Outer Diameter	Motor Reference Number	Driver Unit Reference Number <small>Refer to "2.1 Coding for Driver Unit Reference Number"</small>	Power Voltage	Cable Reference Number	Main Specifications
φ100	M-PS1006KN002	M-EDC-PS1006AB502***	AC200-AC230 [V]	M-C0**SCP03 (Fixed use type) M-C0**SCP13 (Flexible type) **indicates cable length 01: 1 [m] 02: 2 [m] 03: 3 [m] 04: 4 [m] 05: 5 [m] 06: 6 [m] 08: 8 [m] 10: 10 [m] 15: 15 [m] 20: 20 [m] 30: 30 [m]	Internal program 256 channels Pulse train input (Opto-coupler)
		M-EDC-PS1006CB502***	AC100-AC115 [V]		
	M-PS1012KN002	M-EDC-PS1012AB502***	AC200-AC230 [V]		
		M-EDC-PS1012CB502***	AC100-AC115 [V]		
	M-PS1018KN002	M-EDC-PS1018AB502***	AC200-AC230 [V]		
		M-EDC-PS1018CB502***	AC100-AC115 [V]		
φ150	M-PS3015KN002	M-EDC-PS3015AB502***	AC200-AC230 [V]		
		M-EDC-PS3015CB502***	AC100-AC115 [V]		
	M-PS3030KN002	M-EDC-PS3030AB502***	AC200-AC230 [V]		
		M-EDC-PS3030CB502***	AC100-AC115 [V]		
	M-PS3060KN002	M-EDC-PS3060AB502***	AC200-AC230 [V]		
		M-EDC-PS3060CB502***	AC100-AC115 [V]		
M-PS3090KN002	M-EDC-PS3090AB502***	AC200-AC230 [V]			
	M-EDC-PS3090CB502***	AC100-AC115 [V]			
φ100	M-PS1006KN002	M-EDC-PS1006ABC02***	AC200-AC230 [V]	CC-Link compatible Internal program 256 channels	
		M-EDC-PS1006CBC02***	AC100-AC115 [V]		
	M-PS1012KN002	M-EDC-PS1012ABC02***	AC200-AC230 [V]		
		M-EDC-PS1012CBC02***	AC100-AC115 [V]		
	M-PS1018KN002	M-EDC-PS1018ABC02***	AC200-AC230 [V]		
		M-EDC-PS1018CBC02***	AC100-AC115 [V]		
φ150	M-PS3015KN002	M-EDC-PS3015ABC02***	AC200-AC230 [V]		
		M-EDC-PS3015CBC02***	AC100-AC115 [V]		
	M-PS3030KN002	M-EDC-PS3030ABC02***	AC200-AC230 [V]		
		M-EDC-PS3030CBC02***	AC100-AC115 [V]		
	M-PS3060KN002	M-EDC-PS3060ABC02***	AC200-AC230 [V]		
		M-EDC-PS3060CBC02***	AC100-AC115 [V]		
M-PS3090KN002	M-EDC-PS3090ABC02***	AC200-AC230 [V]			
	M-EDC-PS3090CBC02***	AC100-AC115 [V]			

9.2 Accessories (optional)

Item	Reference number	Contents	
Connector	M-E014DCFS1-001	CN2 connector (user side) for standard type	Connector: 54306-5019 (Molex) Connector shell: 54331-0501 (Molex)
	M-E014DCFS1-006	CN2 connector (user side) for CC-Link type	Connector: DHF-PDA10-3-A01 (DDK)
	M-E014DCFS1-002	CN5 connector (user side)	Connector: 231-305/026-000 (WAGO) Wiring lever: 231-131 (WAGO)
	M-E014DCFS1-003	CN6 connector (user side)	Connector: MSTB2, 5/5-STF-5, 08AU (Phoenix Contact)
Mounting bracket	M-E011DCCN1-001	Cable with CN2 connector for CC-Link type	
Manual*	M-E099DC0C2-155	Driver Unit mounting brackets	
	M-E099DC0C2-158	User's Manual (Japanese version)	
	M-E099DC0C2-156	User's Manual (English version)	
	M-E099DC0C2-157	User's Manual for CC-Link (Japanese version)	
Dump resistor	M-E014DCKR1-100	User's Manual for CC-Link (English version)	
	M-E014DCKR1-101	Dump resistor	
		Dump resistor (large capacity)	

*Manuals can be downloaded from the NSK Web site.
<http://www.jp.nsk.com/tech-support/seiki/manual/index.html> (in Japanese)

Worldwide Sales Offices

NSK LTD.-HEADQUARTERS, TOKYO, JAPAN INDUSTRIAL MACHINERY BEARINGS DIVISION-HEADQUARTERS AFTERMARKET BUSINESS DIVISION-HEADQUARTERS AUTOMOTIVE BUSINESS DIVISION-HEADQUARTERS PRECISION MACHINERY & PARTS DIVISION-HEADQUARTERS	www.nsk.com tel: 03-3779-7227 tel: 03-3779-8893 tel: 03-3779-7189 tel: 03-3779-7163	PT. NSK INDONESIA Jakarta Korea: NSK KOREA CO., LTD. Seoul Changwon Plant	www.id.nsk.com tel: 021-252-3458 www.kr.nsk.com tel: 02-3287-0300 tel: 055-287-6001	Netherlands: NSK EUROPEAN DISTRIBUTION CENTRE B.V. Tilburg Poland: NSK EUROPE LTD. WARSAW LIAISON OFFICE Warsaw NSK BEARINGS POLSKA S.A. Kielce Plant NSK EUROPEAN TECHNOLOGY CENTER, POLAND OFFICE Kielce NSK STEERING SYSTEMS EUROPE (POLSKA) SP. Z O. Walbrzych	tel: 013-4647647 tel: 022-645-1525 tel: 041-366-5001 tel: 041-366-5812 tel: 074-664-4101
Africa South Africa: NSK SOUTH AFRICA (PTY) LTD. Johannesburg	tel: 011-458-3600	Malaysia: NSK BEARINGS (MALAYSIA) SDN BHD Shah Alam NSK MICRO PRECISION (M) SDN. BHD. Malaysia Plant	www.my.nsk.com tel: 03-7803-8859 www.my.nsk.com tel: 03-8961-3960	Spain: NSK SPAIN S.A. Barcelona Turkey: NSK RULMANLARI ORTA DOGU TIC. LTD. STI. Istanbul	tel: 093-433-5775 tel: 0216-355-0398
Asia and Oceania Australia: NSK AUSTRALIA PTY. LTD. Melbourne	www.au.nsk.com tel: 03-9764-8302	New Zealand: NSK NEW ZEALAND LTD. Auckland Philippines: NSK REPRESENTATIVE OFFICE Manila	www.nsk-rhp.co.nz tel: 09-276-4992 tel: 02-759-6246	United Kingdom: NSK BEARINGS EUROPE LTD. Peterlee Plant NSK EUROPEAN TECHNOLOGY CENTRE Newark NSK UK Ltd. Newark NSK PRECISION UK LTD. Newark NSK STEERING SYSTEMS EUROPE LTD. Maidenhead	tel: 0191-586-6111 tel: 01636-605-123 tel: 01636-605-123 tel: 01636-605-123 tel: 01628-509-800
China: NSK HONG KONG LTD. Hong Kong Shenzhen KUNSHAN NSK CO., LTD. Kunshan Plant CHANGSHU NSK NEEDLE BEARING CO., LTD. Jiangsu Plant NSK STEERING SYSTEMS DONGGUAN CO., LTD. Dongguan Plant ZHANGJIAGANG NSK PRECISION MACHINERY CO., LTD. Zhangjiagang Plant SUZHOU NSK BEARINGS CO., LTD. Suzhou Plant NSK CHINA TECHNOLOGY CENTER Jiangsu	tel: 2739-9933 tel: 0755-25904886 tel: 0512-5771-5654 tel: 0512-5230-1111 tel: 0769-2262-0960 tel: 0512-5867-6496 tel: 0512-6665-5666 tel: 0512-5771-5654	Singapore: NSK INTERNATIONAL (SINGAPORE) PTE LTD. Singapore NSK SINGAPORE (PRIVATE) LTD. Singapore Taiwan: TAIWAN NSK PRECISION CO., LTD. Taipei TAIWAN NSK TECHNOLOGY CO., LTD. Taipei Thailand: NSK BEARINGS (THAILAND) CO., LTD. Bangkok NSK BEARINGS MANUFACTURING (THAILAND) CO., LTD. Chonburi SIAM NSK STEERING SYSTEMS CO., LTD. Chachoengsao NSK ASIA PACIFIC TECHNOLOGY CENTER (THAILAND) CO., LTD. Chonburi Vietnam: NSK VIETNAM CO., LTD. Hanoi NSK REPRESENTATIVE OFFICE Ho Chi Minh City	www.nsk-singapore.com.sg tel: 6496-8000 tel: 6496-8000 tel: 02-2509-3305 tel: 02-2509-3305 tel: 02641-2150 tel: 038-454-010 tel: 038-522-343 tel: 038-454-631 tel: 04-955-0159 tel: 08-822-7907 www.eu.nsk.com tel: 01628-509-800 tel: 01-30-57-39-39 tel: 02102-4810 tel: 02102-4810 tel: 07393-540 tel: 0299-5191 tel: 011-982-4811	North and South America NSK AMERICAS, INC. (AMERICAN HEADQUARTERS) Ann Arbor Argentina: NSK ARGENTINA SRL Buenos Aires Brazil: NSK BRASIL LTDA. São Paulo Canada: NSK CANADA INC. Toronto Mexico: NSK RODAMIENTOS MEXICANA, S.A. DE C.V. Mexico City United States of America: NSK CORPORATION Ann Arbor NSK AMERICAN TECHNOLOGY CENTER Ann Arbor NSK PRECISION AMERICA, INC. Franklin NSK STEERING SYSTEMS AMERICA, INC. Bennington NSK LATIN AMERICA, INC. Miami	tel: 734-913-7500 tel: 11-4704-5100 tel: 011-3269-4786 tel: 905-890-0740 tel: 55-5390-4312 tel: 734-913-7500 tel: 317-738-5000 tel: 802-442-5448 tel: 305-477-0605
India: RANE NSK STEERING SYSTEMS LTD. Chennai NSK LTD. INDIA BLANCH OFFICE Chennai Delhi Kolkata Mumbai NSK-ABC BEARINGS LTD. Chennai Indonesia: PT. NSK BEARINGS MANUFACTURING INDONESIA Jakarta Plant	tel: 021-6235-0198 www.nsk.com.cn tel: 010-6590-8161 tel: 028-8661-4200 tel: 021-6235-0198 tel: 0431-8898-8682 tel: 021-6235-0198 tel: 021-3365-5757 tel: 0571-2280-1288 tel: 044-274-66002 tel: 044-2446-6862 tel: 0124-4104-530 tel: 033-4001-2062 tel: 022-2838-7787 tel: 044-2466-6862 tel: 021-898-0155	Germany: NSK DEUTSCHLAND GMBH Düsseldorf NSK PRECISION EUROPE GMBH Düsseldorf NEUWEG FERTIGUNG GMBH Munderkingen Plant Italy: NSK ITALIA S.P.A. Milano INDUSTRIA CUSCINETTI S.P.A. Torino Plant	tel: 02102-4810 tel: 02102-4810 tel: 07393-540 tel: 0299-5191 tel: 011-982-4811		

NSK Ltd. has a basic policy not to export any products or technology designated as controlled items by export-related laws. When exporting the products in this brochure, the laws of the exporting country must be observed. Specifications are subject to change without notice and without any obligation on the part of the manufacturer. Every care has been taken to ensure the accuracy of the data contained in this brochure, but no liability can be accepted for any loss or damage suffered through errors or omissions. We will gratefully acknowledge any additions or corrections.

For more information about NSK products, please contact: _____