

Sealed & Shielded Type Double Row Angular Contact Ball Bearings

In addition to the quality and compactness customers already enjoy, NSK now offers sealed and shielded types for greater convenience and protection.

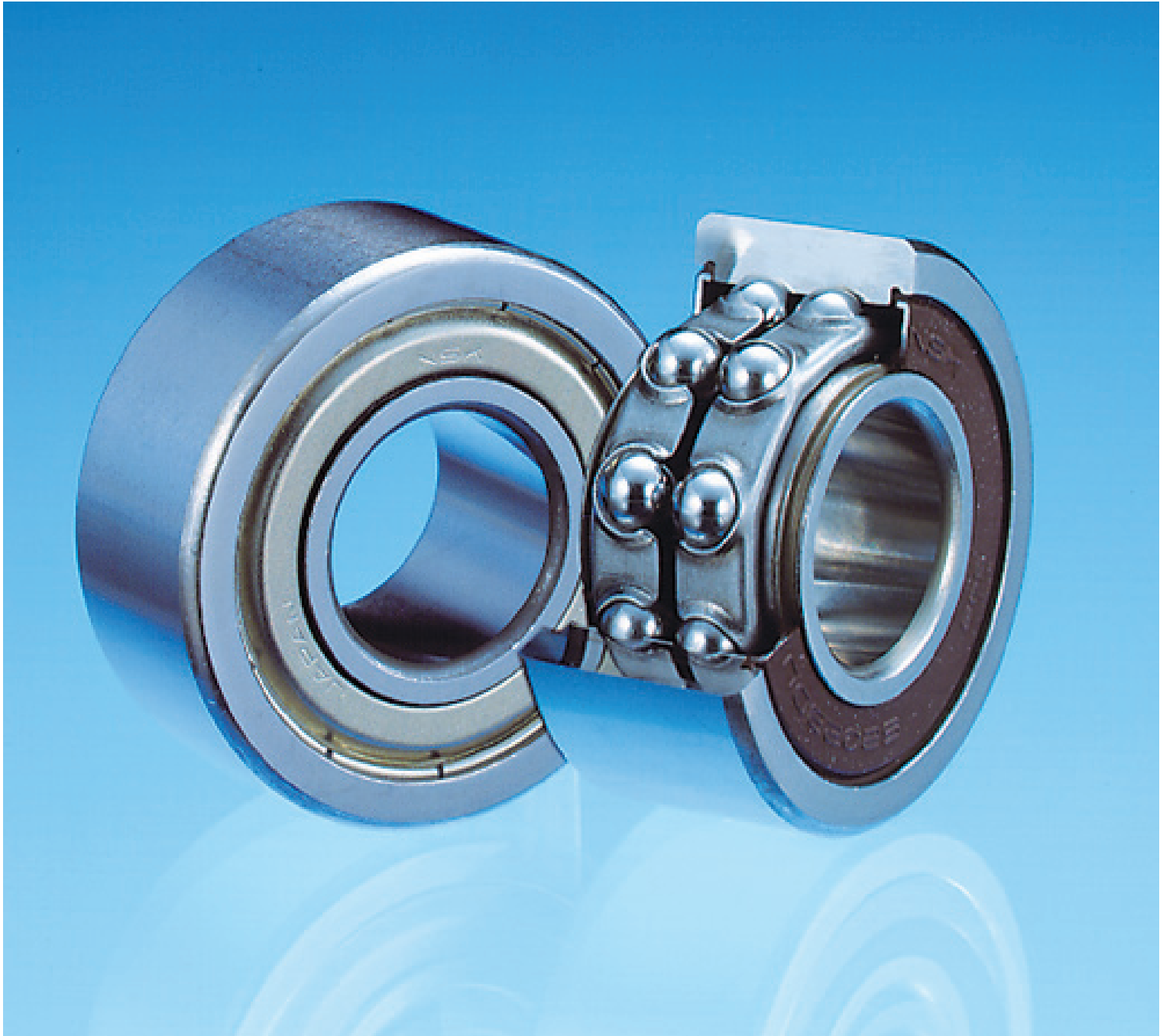

Sealed & Shielded Type Double Row Angular Contact Ball Bearings

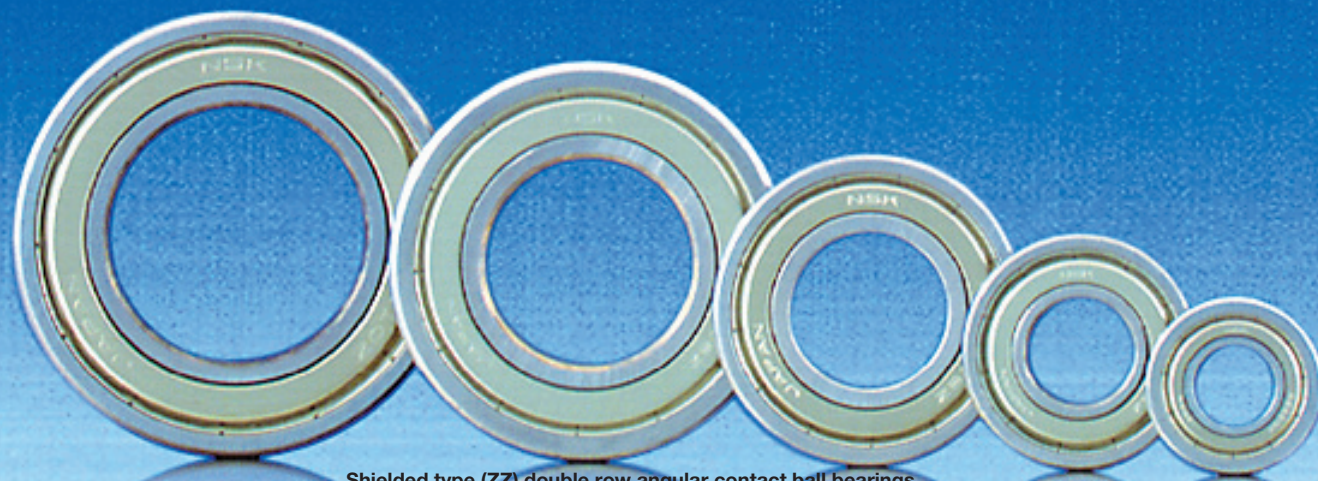

Shielded type (ZZ) double row angular contact ball bearings

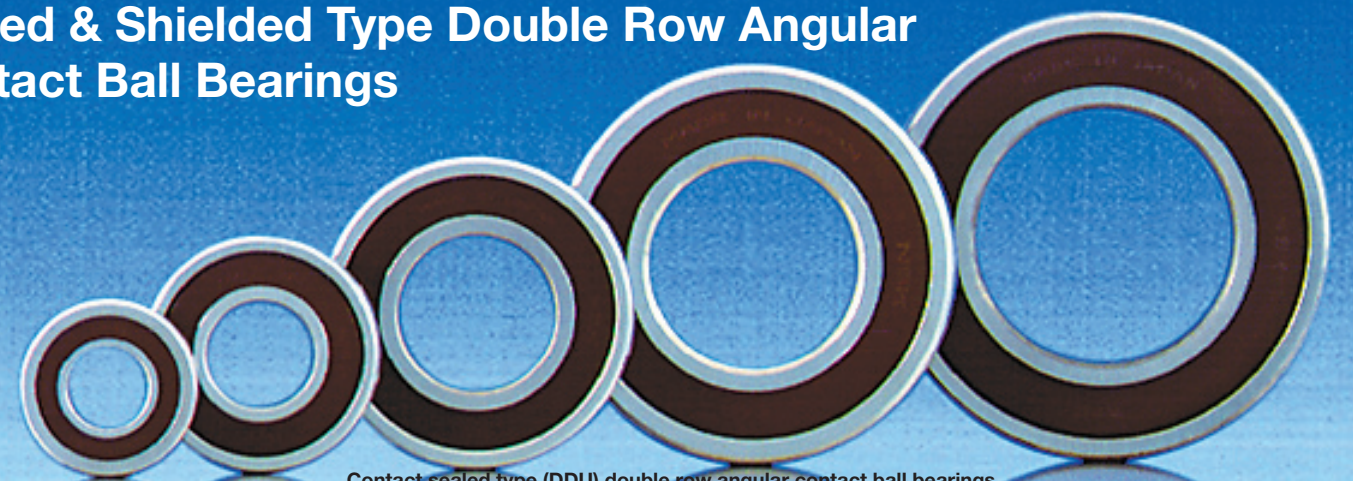

Contact sealed type (DDU) double row angular contact ball bearings

Features of the Sealed & Shielded Type Double Row Angular Contact Ball Bearings:

- Availability of sealed or shielded types in addition to our conventional open-type products
- No need to replace or refill grease since the lubricant is sealed into the bearings
- Compact and narrower than back-to-back duplex (DB) products
- Capable of accommodating heavy radial loads, axial loads in either direction
- High capacity for momentary loads

High-carbon chromium bearing steel

Low-carbon steel and others



Low-carbon steel and others

Vulcanized rubber such as nitrile rubber

Bearing Nomenclature

5202□DDU NS7S
Internal configuration Grease type
 5202□ZZ NS7S

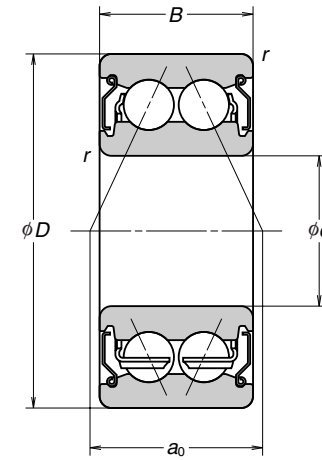

Shielded type (ZZ)

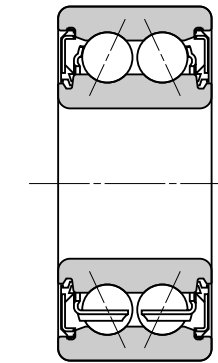

Contact sealed type (DDU)

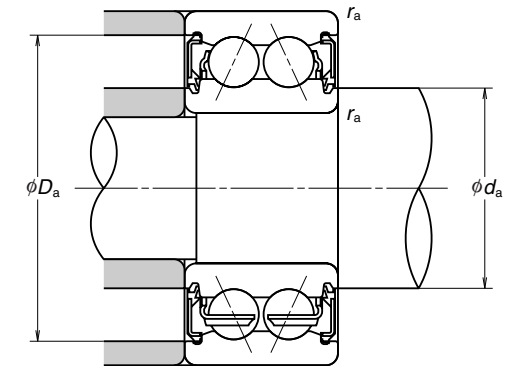

Dynamic Equivalent Load:
 $P = XF_r + YF_a$

e	$F_a / F_r \leq e$		$F_a / F_r > e$	
	X	Y	X	Y
0.68	1	0.92	0.67	1.41

Static Equivalent Load:
 $P_0 = F_r + 0.76F_a$

Bearing Numbers ⁽¹⁾			Boundary Dimensions (mm)				Basic Load Ratings				Limiting Speeds (min ⁻¹)		Abutment and Fillet Dimensions (mm)				Load Center Spacings (mm)
Shielded Type	Sealed Type		d	D	B	r (Minimum)	C _r (N)	C _{or}	C _r {kgf}	C _{or}	Grease Lubrication		d _a (Minimum)	d _a (Maximum)	D _a (Minimum)	r _a (Maximum)	a ₀
											ZZ	DDU					
5200	ZZ	DDU	10	30	14.3	0.6	7 150	3 900	730	400	17 000	15 000	14	15.5	26	0.6	14.5
5201	ZZ	DDU	12	32	15.9	0.6	8 500	5 300	865	540	15 000	12 000	16	19.0	28	0.6	16.3
5202	ZZ	DDU	15	35	15.9	0.6	8 500	5 300	865	540	13 000	12 000	19	19.0	31	0.6	16.3
5302	ZZ	DDU	15	42	19.0	1	14 700	9 100	1 500	930	11 000	10 000	21	22.5	36	1	21.0
5203	ZZ	DDU	17	40	17.5	0.6	12 700	8 300	1 290	850	11 000	10 000	21	23.5	36	0.6	20.1
5303	ZZ	DDU	17	47	22.2	1	19 600	12 400	2 000	1 270	10 000	9 500	23	25.5	41	1	24.3
5204	ZZ	DDU	20	47	20.6	1	15 900	10 700	1 620	1 090	10 000	9 000	26	26.5	41	1	23.0
5304	ZZ	DDU	20	52	22.2	1.1	19 700	12 800	2 010	1 300	9 000	8 500	27	28.0	45	1	25.4
5205	ZZ	DDU	25	52	20.6	1	16 900	12 300	1 730	1 260	8 500	7 500	31	32.0	46	1	25.4
5305	ZZ	DDU	25	62	25.4	1.1	25 200	18 200	2 570	1 850	7 500	6 300	32	38.5	55	1	30.9
5206	ZZ	DDU	30	62	23.8	1	25 200	18 200	2 570	1 850	7 100	6 300	36	38.5	56	1	30.9
5306	ZZ	DDU	30	72	30.2	1.1	39 000	28 700	4 000	2 920	6 300	5 300	37	44.5	65	1	36.6
5207	ZZ	DDU	35	72	27.0	1.1	34 000	25 300	3 500	2 580	6 300	5 300	42	45.0	65	1	36.3
5307	ZZ	DDU	35	80	34.9	1.5	44 000	33 500	4 500	3 400	5 600	4 800	44	50.5	71	1.5	41.5
5208	ZZ	DDU	40	80	30.2	1.1	36 500	29 000	3 700	2 960	5 600	4 800	47	50.5	73	1	39.4
5308	ZZ	DDU	40	90	36.5	1.5	49 500	38 000	5 050	3 900	5 300	4 500	49	53.0	81	1.5	43.8
5209	ZZ	DDU	45	85	30.2	1.1	41 500	33 500	4 250	3 450	5 000	4 300	52	55.5	78	1	42.5
5309	ZZ	DDU	45	100	39.7	1.5	61 500	48 500	6 250	4 950	4 500	3 900	54	61.5	91	1.5	50.4
5210	ZZ	DDU	50	90	30.2	1.1	40 500	36 000	4 100	3 700	4 800	4 000	57	60.0	83	1	44.0
5310	ZZ	DDU	50	110	44.4	2	74 000	59 500	7 550	6 050	4 300	3 600	62	67.0	98	2.5	54.8
5211	ZZ	DDU	55	100	33.3	1.5	49 500	43 500	5 050	4 450	4 300	3 600	64	66.5	91	1.5	49.2
5311	ZZ	DDU	55	120	49.2	2	88 000	71 500	8 950	7 300	3 800	3 200	67	73.5	108	2.5	60.0

Note: (1) These bearing numbers are for the double-shielded and double-sealed types. Single-shielded and single-sealed types are also available.

Worldwide Sales Offices

NSK LTD.-HEADQUARTERS, TOKYO, JAPAN INDUSTRIAL MACHINERY BEARINGS DIVISION-HEADQUARTERS AFTERMARKET BUSINESS DIVISION-HEADQUARTERS AUTOMOTIVE BUSINESS DIVISION-HEADQUARTERS PRECISION MACHINERY & PARTS DIVISION-HEADQUARTERS	www.nsk.com tel: 03-3779-7227 tel: 03-3779-8893 tel: 03-3779-7189 tel: 03-3779-7163	PT. NSK INDONESIA Jakarta	www.id.nsk.com tel: 021-252-3458	Netherlands: NSK EUROPEAN DISTRIBUTION CENTRE B.V. Tilburg	tel: 013-4647647
Africa South Africa: NSK SOUTH AFRICA (PTY) LTD. Johannesburg	tel: 011-458-3600	Korea: NSK KOREA CO., LTD. Seoul Changwon Plant	www.kr.nsk.com tel: 02-3287-0300 tel: 055-287-6001	Poland: NSK EUROPE LTD. WARSAW LIAISON OFFICE Warsaw	tel: 022-645-1525
Asia and Oceania Australia: NSK AUSTRALIA PTY. LTD. Melbourne	www.au.nsk.com tel: 03-9764-8302	Malaysia: NSK BEARINGS (MALAYSIA) SDN BHD Shah Alam NSK MICRO PRECISION (M) SDN. BHD. Malaysia Plant	www.my.nsk.com tel: 03-7803-8859 www.my.nsk.com tel: 03-8961-3960	NSK BEARINGS POLSKA S.A. Kielce Plant	tel: 041-366-5001
China: NSK HONG KONG LTD. Hong Kong Shenzhen	tel: 2739-9933 tel: 0755-25904886	New Zealand: NSK NEW ZEALAND LTD. Auckland	www.nsk-rhp.co.nz tel: 09-276-4992	NSK EUROPEAN TECHNOLOGY CENTER, POLAND OFFICE Kielce	tel: 041-366-5812
KUNSHAN NSK CO., LTD. Kunshan Plant	tel: 0512-5771-5654	Philippines: NSK REPRESENTATIVE OFFICE Manila	tel: 02-759-6246	NSK STEERING SYSTEMS EUROPE (POLSKA) SP. ZO. O. Walbrzych	tel: 074-664-4101
CHANGSHU NSK NEEDLE BEARING CO., LTD. Jiangsu Plant	tel: 0512-5230-1111	Singapore: NSK INTERNATIONAL (SINGAPORE) PTE LTD. Singapore	tel: 6496-8000	Spain: NSK SPAIN S.A. Barcelona	tel: 093-433-5775
NSK STEERING SYSTEMS DONGGUAN CO., LTD. Dongguan Plant	tel: 0769-2262-0960	NSK SINGAPORE (PRIVATE) LTD. Singapore	www.nsk-singapore.com.sg tel: 6496-8000	Turkey: NSK RÜMLANLARI ORTA DOGU TIC. LTD. STI. Istanbul	tel: 0216-355-0398
ZHANGJIAGANG NSK PRECISION MACHINERY CO., LTD. Jiangsu Plant	tel: 0512-5867-6496	Taiwan: TAIWAN NSK PRECISION CO., LTD. Taipei	tel: 02-2509-3305	United Kingdom: NSK BEARINGS EUROPE LTD. Peterlee Plant	tel: 0191-586-6111
SUZHOU NSK BEARINGS CO., LTD. Jiangsu Plant	tel: 0512-6665-5666	TAIWAN NSK TECHNOLOGY CO., LTD. Taipei	tel: 02-2509-3305	NSK EUROPEAN TECHNOLOGY CENTRE Newark	tel: 01636-605-123
NSK CHINA TECHNOLOGY CENTER Jiangsu	tel: 0512-5771-5654	Thailand: NSK BEARINGS (THAILAND) CO., LTD. Bangkok	tel: 02641-2150	NSK UK Ltd. Newark	tel: 01636-605-123
NSK (SHANGHAI) TRADING CO., LTD. Shanghai	tel: 021-6235-0198	NSK BEARINGS MANUFACTURING (THAILAND) CO., LTD. Chonburi	tel: 038-454-010	NSK PRECISION UK LTD. Newark	tel: 01636-605-123
NSK REPRESENTATIVE OFFICES Beijing Guangzhou Chengdu	www.nsk.com.cn tel: 010-6590-8161 tel: 028-3786-4833 tel: 028-8661-4200	SIAM NSK STEERING SYSTEMS CO., LTD. Chachoengsao	tel: 038-522-343	NSK STEERING SYSTEMS EUROPE LTD. Maidenhead	tel: 01628-509-800
NSK (CHINA) INVESTMENT CO., LTD. Shanghai Changchun	tel: 021-6235-0198 tel: 0431-8898-8682	NSK ASIA PACIFIC TECHNOLOGY CENTER (THAILAND) CO., LTD. Chonburi	tel: 038-454-631	North and South America NSK AMERICAS, INC. (AMERICAN HEADQUARTERS) Ann Arbor	tel: 734-913-7500
NSK CHINA SALES CO., LTD. Shanghai	tel: 021-6235-0198	Vietnam: NSK VIETNAM CO., LTD. Hanoi	tel: 04-955-0159	Argentina: NSK ARGENTINA SRL Buenos Aires	tel: 11-4704-5100
NSK-WARNER (SHANGHAI) CO., LTD. Plant	tel: 021-3365-5757	NSK REPRESENTATIVE OFFICE Ho Chi Minh City	tel: 08-822-7907	Brazil: NSK BRASIL LTDA. São Paulo	www.br.nsk.com tel: 011-3269-4786
AKS PRECISION BALL (HANGZHOU) CO., LTD. Plant	tel: 0571-2280-1288	Europe NSK EUROPE LTD. (EUROPEAN HEADQUARTERS) Maidenhead	www.eu.nsk.com tel: 01628-509-800	Canada: NSK CANADA INC. Toronto	www.ca.nsk.com tel: 905-890-0740
India: RANE NSK STEERING SYSTEMS LTD. Chennai	tel: 044-274-66002	France: NSK FRANCE S.A.S Paris	tel: 01-30-57-39-39	Mexico: NSK RODAMIENTOS MEXICANA, S.A. DE C.V. Mexico City	www.mx.nsk.com tel: 55-5390-4312
NSK LTD. INDIA BLANCH OFFICE Chennai	tel: 044-2446-6862	Germany: NSK DEUTSCHLAND GMBH Düsseldorf	tel: 02102-4810	United States of America: NSK CORPORATION Ann Arbor	www.us.nsk.com tel: 734-913-7500
Delhi	tel: 0124-4104-530	NSK PRECISION EUROPE GMBH Düsseldorf	tel: 02102-4810	NSK AMERICAN TECHNOLOGY CENTER Ann Arbor	tel: 734-913-7500
Kolkata	tel: 033-4001-2062	NEUWEG FERTIGUNG GMBH Munderkingen Plant	tel: 07393-540	NSK PRECISION AMERICA, INC. Franklin	www.npa.nsk.com tel: 317-738-5000
Mumbai	tel: 022-2838-7787	Italy: NSK ITALIA S.P.A. Milano	tel: 0299-5191	NSK STEERING SYSTEMS AMERICA, INC. Bennington	www.nsa.nsk.com tel: 802-442-5448
NSK-ABC BEARINGS LTD. Chennai	tel: 044-2466-6862	INDUSTRIA CUSCINETTI S.P.A. Torino Plant	tel: 011-982-4811	NSK LATIN AMERICA, INC. Miami	www.la.nsk.com tel: 305-477-0605

NSK Ltd. has a basic policy not to export any products or technology designated as controlled items by export-related laws. When exporting the products in this brochure, the laws of the exporting country must be observed. Specifications are subject to change without notice and without any obligation on the part of the manufacturer. Every care has been taken to ensure the accuracy of the data contained in this brochure, but no liability can be accepted for any loss or damage suffered through errors or omissions. We will gratefully acknowledge any additions or corrections.

For more information about NSK products, please contact: _____



Printed on 100% recycled paper.