

aerospace  
climate control  
electromechanical  
filtration  
fluid & gas handling  
hydraulics  
pneumatics  
process control  
sealing & shielding

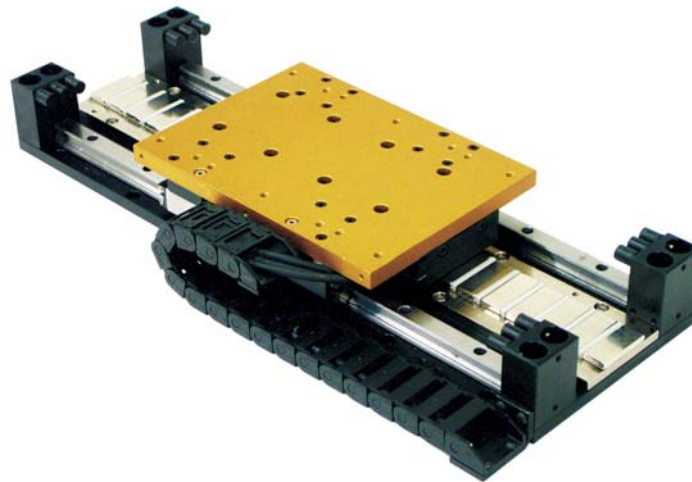

# Trilogy Linear Motor & Linear Motor Positioners

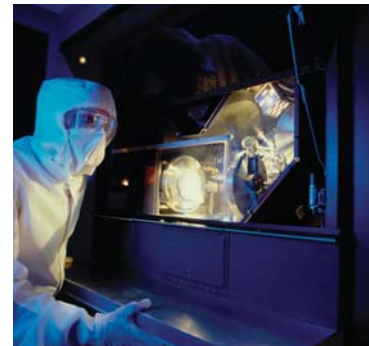

ENGINEERING YOUR SUCCESS.

# Parker Hannifin Corporation

A Fortune 300 company with annual sales exceeding \$9 billion and more than 400,000 customers in 46 countries, Parker Hannifin is the world's leading supplier of innovative motion control components and system solutions serving the industrial, mobile, and aerospace markets. We are the only manufacturer offering customers a choice of electromechanical, hydraulic, pneumatic, or computer-controlled motion systems.

## Total System Solutions

Parker's team of highly qualified application engineers, product development engineers, and system specialists can turn pneumatic, structural, and electromechanical products into an integrated system solution. Moreover, our Selectable Levels of Integration™ allows you to choose the appropriate system, subsystem, or component to meet your specific need.



Parker offers complete engineered systems.

## First in Delivery, Distribution, and Support

In today's competitive, fast-moving economy, what good is an application that isn't ready on time? This is especially true when compressed design cycles make the quick delivery of critical components essential. With factories strategically located on five continents, Parker offers an unrivaled delivery record, getting solutions out our door and onto your floor faster than ever.

Parker also has the industry's largest global distribution network, with more than 8,600 distributors worldwide. Each of these locations maintains ample product inventory to keep your downtime to a minimum. And many distributors have in-house design capabilities to support your system and subsystem requirements.

Throughout the design process, Parker's factory-trained electro-mechanical engineers work hand in hand with you and day or night at 1-800-C-Parker. Our operators will connect you with a live, on-call representative who will identify replacement parts or services for all motion technologies.



Parker world headquarters in Cleveland



## Training

Parker's best-in-class technology training includes hands-on classes, Web-based instruction, and comprehensive texts for employees, distributors, and customers. Parker also provides computer-based training, PowerPoint presentations, exams, drafting and simulation software, and trainer stands.

## parkermotion.com

Our award-winning Web site is your single source for

- Product information
- Downloadable catalogs
- Motion-sizing software
- 3D design files
- Training materials
- Product-configuration software
- RFQ capabilities



## 24/7 Emergency Breakdown Support

The Parker product information center is available any time of the day or night at 1-800-C-Parker. Our operators will connect you with a live, on-call representative who will identify replacement parts or services for all motion technologies.



# PERFORMANCE

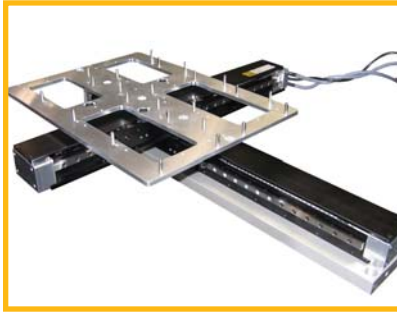

## PRECISION

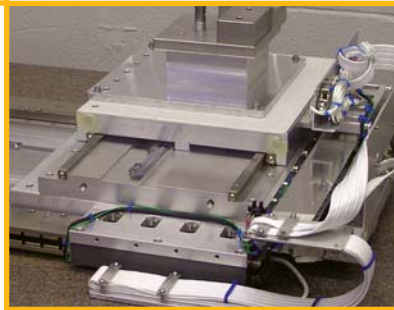

## ACCURACY

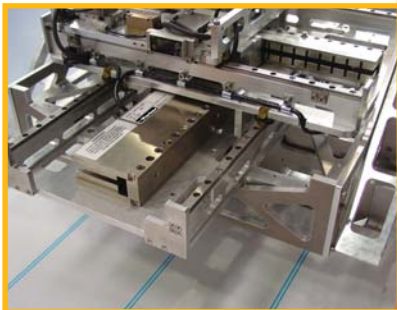
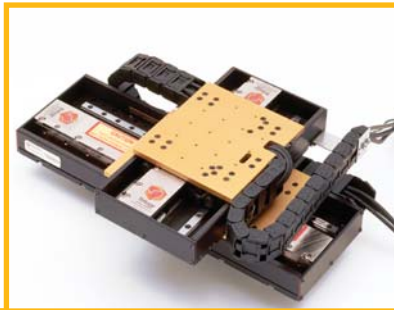
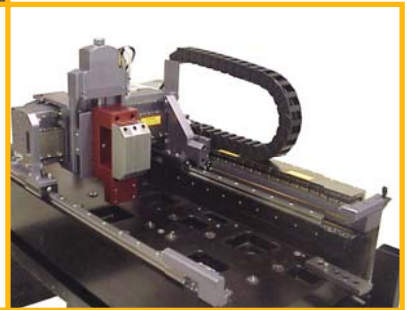

## SPEED

Parker Hannifin has been providing innovative automation solutions for decades. This spirit of innovation continues within the exploding market of linear motor technology. In 2003, Parker acquired Trilogy Corporation, one of the most recognizable brands in linear motors. The powerful combination of Parker's and Trilogy's patented linear motor solutions gives automation and robotics customers distinct performance enhancements and cost of ownership benefits over competing technologies. With a full complement of linear motor components and fully engineered positioning systems, Parker has the right solution to increase productivity and to enhance the accuracy and dynamic performance of your machine.

#### **Linear Motor Advantages –**

- High Speeds
- High Accelerations
- Fast Response – 100 times that of a mechanical system
- Stiffness – spring rate better than a mechanical system
- Zero Backlash – direct drive technology
- Maintenance Free Operation – mechanical simplicity due to reduced component count
- Long Travels Without Performance Loss
- Suitable for Vacuum and Extreme Environments

#### **Applications –**

- Semiconductor and Electronics
- Flat Panel and Solar Panel Manufacturing
- Medical and Life Sciences
- Machine Tools
- Optics and Photonics
- Large Format Printing, Scanning and Digital Fabrication
- Packaging and Material Handling
- Automated Assembly

Parker has one of the broadest offerings in available linear motor technologies. From component or “kit” style motors, packaged positioning tables, to complete custom engineered systems, Parker can provide a solution for any linear motion requirement.

#### **Component Motors –**

- Ironless Motors – ultra high performance and zero cogging
- Ironcore Motors – highest power per package size
- Slotless Motors – good linear force, smooth translation, low cost

#### **Industrial Grade Positioners –**

- Pre-engineered, ready-to-run packages
- Drive / amplifier connectorization
- High dynamic velocity and accelerations
- High precision

#### **Precision Grade Positioners –**

- Pre-engineered, ready to run packages
- Drive / amplifier connectorization
- Extremely high precision
- Miniature positioners available

#### **Multi-axis Capability –**

- Standard transition brackets available
- Custom configurations
- Dowel pinning for superior orthogonality
- Cable Management

#### **Custom Engineered Systems –**

- Let Parker's extensive motion design experience, systematic project management process, and global infrastructure solve your most demanding motion problems.
- Collaborative development cycle aligns customer goals and rigorous performance specifications with a complete engineered solution.



# Contents

## Linear Motor Engineering Reference Guide

..... 6

## Linear Motors

I-Force Ironless Linear Motors..... 17

Ripped Ironcore Linear Motors..... 40



## Industrial Grade Linear Motor Positioner

I-Force Ironless Linear Motors Positioners..... 53

Ripped Ironcore Linear Motors Positioners..... 74

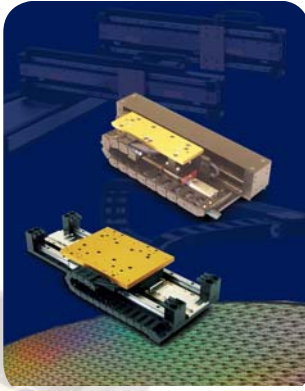

## Precision Grade Linear Motors

400LXR..... 88

MX80L..... 99

LX80L..... 106



# Linear Motor Engineering Reference Guide

## 1. Advantages of linear motors

### 1.1 What are linear motors?

Simply stated, a linear motor is the same as a rotary motor that has been “unwrapped.” They operate exactly the same as rotary motors, where the same electromagnetic equations that describe how a rotary motor produces torque now describe how a linear motor produces a direct force.

In many applications, linear motors offer distinct advantages over conventional rotary drive systems. When using a linear motor, there is no need to couple the motor to the load by means of intermediate mechanical components such as gears, ballscrews, or belt drives. The load is directly connected to the motor. Therefore, there is no backlash or elasticity from the moving elements. Thus, the dynamic behavior of the servo control is improved and higher levels of accuracy are achieved.

The absence of a mechanical transmission component results in a drive system with low inertia and noise. In addition, mechanical wear only occurs in the guidance system. As a result, linear motors have better reliability and lower frictional losses than traditional rotary drive systems.

### 1.2 Differences in construction

The differences in construction between a direct-drive linear motor and a conventional rotary drive system are shown in (Fig. 1 and Fig. 2.) using the examples of a linear motor drive and a ballscrew drive. Due to the absence of mechanical transmission elements converting rotary movement into linear movement, the axis fitted with a linear motor has a much simpler mechanical construction, resulting in a low-inertia drive for highly dynamic applications. Though not always required, the linear motor table is equipped with a linear encoder, which provides extremely accurate positional feedback.

Though the linear encoder in (Fig. 2) can be considered a high-cost component, the selection of the feedback system can be optimally suited to the requirements of the application. For instance, Parker offers extremely high-resolution optical encoders for applications with demanding precision requirements. In addition, Parker offers lower-resolution, low-cost magnetic encoders for applications where overall system cost is a concern. Actually, it is not uncommon for a linear motor with an economical form of feedback to outperform and actually cost the same or even less than a rotary system using a precision ground ballscrew.

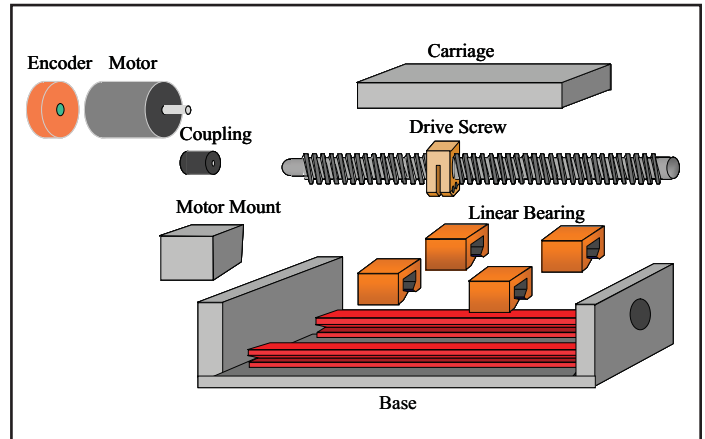

Fig. 1: Precision table fitted with ballscrew drive

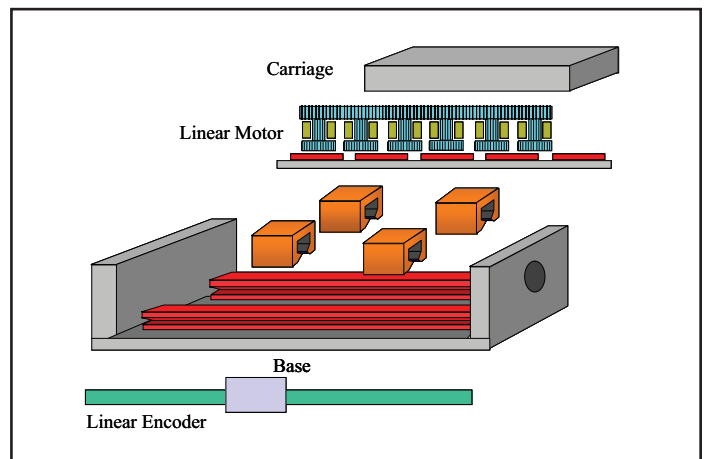

Fig. 2: Precision table fitted with linear motor



*Fig. 3: Linear motor components include a separate coil and magnet rail*

## 2.0 Types of linear motors

There are many different types of linear motors. Each type exhibits its inherent advantages and benefits to the user. Parker manufactures 3 styles of linear motors – ironless, ironcore, and an interesting variant known as the “slotless” design.

Linear motors are either offered as individual components or complete systems. Components, or “kits” (Fig. 3), consist of a motor coil and separate magnet rail. The coil assembly is known as the “forcer” or sometimes as the “primary” element. The forcer generally consists of the motor coil and an attachment plate or mounting bar which allows the coil to connect to the carriage.

The motor cables typically exit from one side of the package. The magnet track is sometimes referred to as the “secondary” element. Depending on the type of linear motor used, the magnet track can either be a single row of magnets or a double-sided configuration offering balanced attraction forces.

A complete linear motor system (Fig. 4) is typically made up of the individual motor components, base, bearings, feedback elements, and cable management.



*Fig. 4: Linear motor positioning systems include a base, bearings, carriage, feedback and typically cable management*

By selecting linear motor components, the user is given an economical solution and is allowed complete flexibility with respect to integration into the machine. However, this requires a high degree of specific knowledge on the part of the machine builder. The designing engineer must have an understanding of the motor characteristics, linear feedback technology, cooling methods, and the performance of the servo amplifier and control system.

By selecting integrated linear motor positioning systems, the design engineer is given a pre-engineered, robustly designed, fully tested package. This takes the worry out of designing and aligning bearings, encoders, heat sinks, cables, connectors, travel stops, and limit / home sensors. Parker linear motor tables provide all this and more in easily mounted and ready-to-run packages.

## 2.1 Ironcore motors

Ironcore motors consist of aforcer which rides over a single magnet rail (Fig. 5). The forcer is made of copper windings wrapped around iron laminations. The back iron provides an efficient path for the magnetic flux to circulate between the motor and the magnet rail. In addition, there is an efficient path for heat to escape the motor. This ironcore design allows for extremely high forces and efficient cooling. In fact, the ironcore design offers the highest force available per unit volume. Finally, the ironcore design is economically attractive because only one row of magnet material is required.

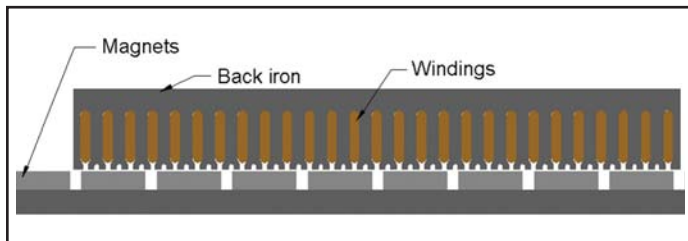

Fig. 5: Ironcore linear motor

One of the drawbacks of the ironcore design is that the motor has a high attractive force between the forcer and the magnet track. The attractive force can range from 5 – 13 times the rated force of the motor. This force must be supported by the bearing system of the motor. In addition, the high attractive force makes installation more challenging than other linear motor designs.

Another drawback of the ironcore design is the presence of cogging forces. Cogging occurs when the iron laminations exert a horizontal force on the motor in order to line up with their preferred positions over the magnets. Cogging limits the smoothness of motion systems because the force generated by the motor must change with position in order to maintain a constant velocity.

Parker Trilogly has developed a patent-pending Anti-Cog technology that virtually eliminates cogging and allows ironcore motors to be used in applications where only ironless motors were considered before. This offers the machine builder a powerful combination of extremely high force and smooth operation in an economical package.

To summarize the advantages and disadvantages of ironcore motors:

### Ironcore advantages:

- **High Force per Size** - Uses laminations to concentrate the flux field.
- **Lower Cost** - Open face design only uses one row of magnets.
- **Good Heat Dissipation** - Because of laminations and large surface area, heat can be removed easily.

### Ironcore disadvantages:

- **Normal attractive force** – 5 to 13 times greater than force generated.
- **Cogging** – Limits the smoothness of motion and creates velocity ripple. *This is counteracted by Parker Trilogly's patent pending Anti-Cog technology.*

Parker Trilogly offers ironcore motors both as components and as pre-engineered, fully integrated positioning systems. Please refer to the catalog for the **RIPPED Series** Ironcore Linear Motors and the **TR Series** Ironcore Linear Motor Positioners (Fig. 6 and Fig. 7).



Fig. 6: Ripped Series Ironcore Linear Motor

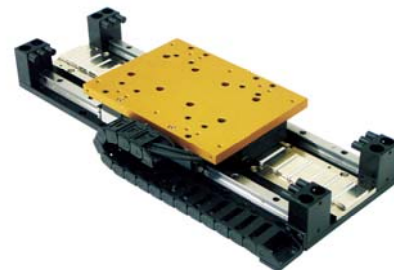

Fig. 7: Parker Trilogly's TR Series Ironcore Linear Motor Positioner

## 2.2 Ironless Motors

Ironless motors consist of a forcer which rides between dual magnet rails (Fig. 8). They are also known as “aircore” or “U-channel” motors. The forcer does not have any iron laminations in the coil – hence the name ironless. Instead, the copper windings are encapsulated and located in the air gap between the two rows of magnets. Because the motors are ironless, there are no attractive forces or cogging forces between the forcer and the magnet track.

In addition, the forcers have lower mass than their ironcore counterparts. What results is a motor design that allows for extremely high accelerations and overall dynamic performance. The ironless design has zero cogging and the lack of attractive force allows for extended bearing life and, in some applications, the ability to use smaller bearings.

While the high dynamic performance and zero cogging motion make the ironless motors a powerful design, they are not as thermally efficient as their ironcore counterparts. A small contacting surface area and a long thermal path from the winding base to the cooling plate makes the full-load power of these motors low. In addition, the dual row of magnets increases the overall cost of these motors in relation to the generated force and stroke length.

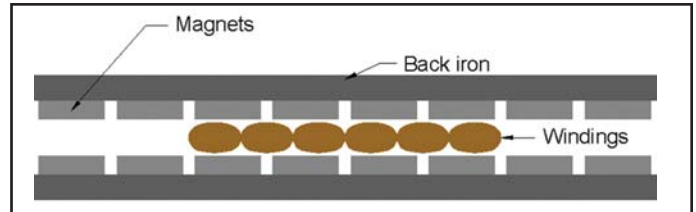

Fig. 8: Ironless Linear Motor

Parker Trilogy's patented I-beam shape and overlapping winding design provides very high forces in a compact package. In addition, the design is more thermally efficient than tradition ironless motor designs.

By overlapping the windings (Fig. 9) instead of arranging them side-by-side, Parker Trilogy is able to provide a motor with a very high power density. The result is a package size considerably smaller than competitive motors with similar force capabilities.

Parker Trilogy creates the I-beam shape by flaring out the end turns of the motor at a 90-degree angle. The end turns of a linear motor coil do not contribute to the horizontal force component of the motor. Instead of producing force, the end turns simply produce heat. Parker's I-beam shaped design allows for better heat transfer between the motor coils and the heat sink by increasing the contacting surface area between components (Fig. 10). The combination of overlapped windings and the I-Beam shape creates a more thermally efficient motor than most traditional ironless motors. As a result, the payload will experience less thermal expansion due to heat from the motor. In high precision applications, thermal expansion can adversely affect the overall system accuracy. Parker Trilogy motors will help maintain system accuracy by running at lower operating temperatures than our competitors. In addition, there are added benefits of the I-beam shape by lowering the overall profile height and creating a stiffer mechanical structure.

What results is a compact motor design with high force and extraordinary thermal characteristics.

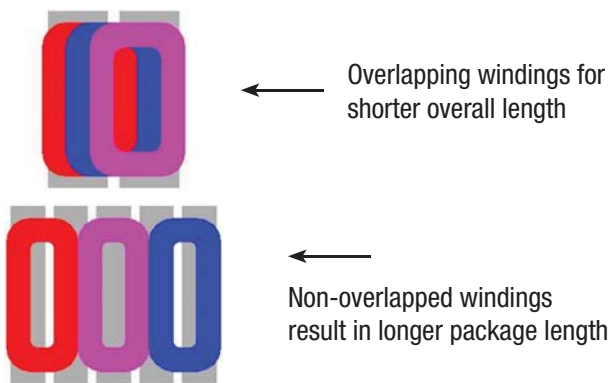

Fig. 9: Overlapping Windings

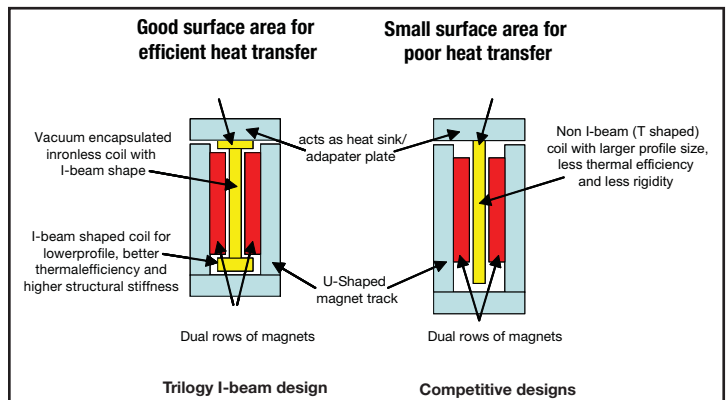

Fig. 10: Parker Trilogy's Patented I-Beam Design

To summarize the advantages and disadvantages of ironless motor designs:

**Ironless advantages:**

- **No Attractive Force** - Balanced dual magnet track. Safe and easy to handle. No forces to deal with during assembly.
- **No Cogging** - Ironlessforcer for zero cogging and ultimate smoothness.
- **Low Weight Forcer** - No iron means higher acceleration and deceleration rates, higher mechanical bandwidth.
- **Air Gap Forgiving** - easy to align and install.

**Ironless disadvantages:**

- **Heat dissipation** - Higher thermal resistance. Parker Trilogy's I-beam design helps mitigate this issue.
- **Power per package** - Lower RMS power when compared to ironcore designs.
- **Higher cost** - Uses twice as many magnets.

Parker Trilogy offers ironless motors in both component kits and complete pre-engineered positioning systems. Please refer to the catalog for the “**I-Force**” and “**ML50**” ironless linear motors and the “**T Series**” linear motors positioners (Fig. 11 and 12).



Fig. 11: ML50 Ironless Linear Motor

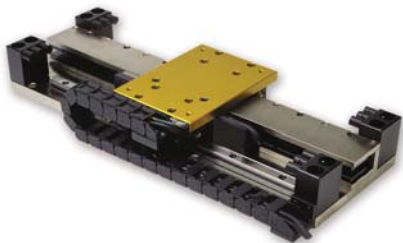

Fig. 12: T2D Series Linear Motor Positioner

**2.3 Slotless Motors**

Slotless motors are an interesting variant of linear motor which combines several of the design elements of ironcore and ironless motors. In a slotless motor (Fig. 13), the forcer has no iron toothed laminations. The coils are wound without iron and are located underneath a “back iron” plate. The forcer then operates along a single magnet row. The slotless motor design can be thought of as a sort of hybrid between ironcore and ironless linear motor designs.

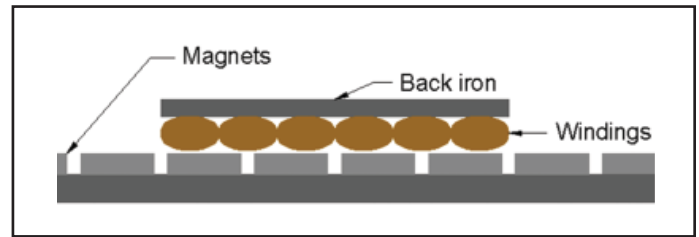

Fig. 13: Slotless Linear Motor

What results is a motor with the following characteristics:

**Slotless linear motor advantages:**

- Single-row magnet bar
- Lower cost (compared to ironless design)
- Better heat dissipation (compared to ironless design)
- More force per package size (compared to ironless design)
- Lighter weight and lower inertia forcer (compared to ironcore design)
- Lower attractive forces (compared to ironcore designs) – extended bearing life and smaller bearings in some applications
- Less cogging (compared to ironcore designs)

**Slotless linear motor disadvantages:**

- Some attractive force and cogging
- Air gap is critical
- Less efficient than both ironcore and ironless – more heat to do the same job

Parker offers slotless motors in both component kits and precision positioning systems. Please refer to this catalog under 400LXR Positioners or to the “SL Series” linear motor section on [www.parkermotion.com](http://www.parkermotion.com) (Fig. 14 and 15).



Fig. 14: SL Series Slotless Linear Motors



Fig. 15: 404LXR Slotless Linear Motor Positioning System

### 3.0 Guide Systems

Even though a linear motor system lacks the rotary transmission components of traditional positioning systems, the user is still required to provide some sort of linear guide / bearing. Typically, a linear bearing must be selected based on high speed and acceleration capability, long service life, high accuracy, low maintenance costs, high stiffness, and low noise. Other considerations may include, for example, the site space available, the mounting accuracy (flatness, parallelism, inclination), and the thermal expansion.

Different guide systems are available to fulfill these requirements:

- Slide bearings (dry running or hydrodynamic)
- Hydrostatic bearings
- Aerostatic bearings (air bearings)
- Track rollers (steel or plastic roller wheels)
- Rolling-contact bearings (square rail, cross roller, or round rail)
- Magnetic bearings

In practice, slide bearings, rolling-contact bearings, and air bearings are the most popular. For applications with low demands on precision and load-bearing capacity, dry-running slide bearings may be a suitable option. Guide systems based on rolling-contact like square rail and cross roller bearings exhibit good stiffness and excellent load-bearing capability. In addition, they offer excellent straightness and flatness over the length of travel. Air bearings offer the ultimate in performance. With practically no limits to max speed and acceleration and virtually no breakaway forces, air bearings are the best solution for ultra-high precision applications.

### 4.0 Servo Control and Feedback

Linear motors can offer the ultimate in high precision and motion dynamics. However, overall system performance is dependent on other components – particularly the servo controller and feedback mechanism used. In this section, we will examine how linear motors are commutated, how their position is sensed, and how it is important to have an adequate controller to optimize system performance.

Figure 16 shows the traditional cascaded structure of servo motor control. The same structure can be applied to linear motors. One advantage is that the position sensor can typically be located right at or closer to the load, thus improving the overall accuracy of the system.

One drawback is that the lack of a traditional mechanical transmission results in the effects of external forces being significantly greater. For this reason, the quality of the position signal (resolution and accuracy) and the performance of the servo controller (sampling time, trajectory update, and control algorithms used) are of prime importance in determining the degree of “positional stiffness” that can be achieved.

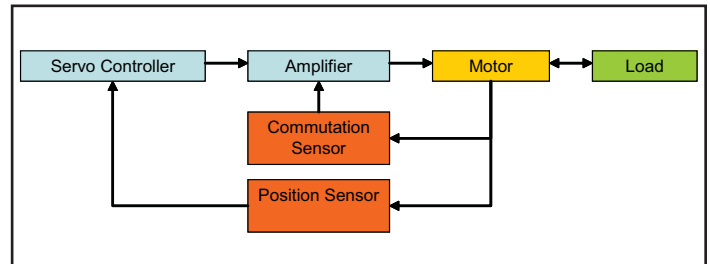

Fig 16(a): Servo Motor Control (position sensor located at motor)

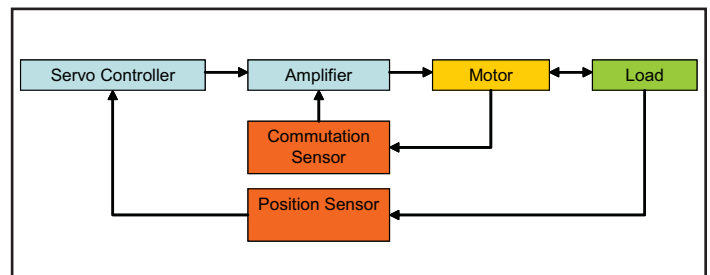

Fig 16(b): Servo Motor Control (position sensor located at load)

#### 4.1 Commutation of the motor

In traditional rotary servo systems, it is important for the amplifier to know the position of the rotor. This way it can properly switch current through the motor phases in order to achieve the desired rotation of the shaft. Many times, three digital Hall effect sensors (spaced 60 degrees or 120 degrees apart) are used in order to provide positional information of the shaft within 6 states.

The same principle applies to linear motors. The amplifier must know the position of the forcer in relationship to the magnet rail in order to properly switch the windings. Rather than aligning the Hall effect devices (HEDs) within one complete revolution of the shaft, the Halls are matched to the magnetic pole pitch of the motor. The “pole pitch” is the linear distance traveled within one electrical cycle of the motor and is analogous to one revolution of a rotary motor.

Once the amplifier establishes the position of the forcer within the electrical cycle, it will then switch the motor phases whenever a transition occurs in the Hall states. This is known as *trapezoidal commutation*.

In most modern servo amplifiers, the position of the forcer need only be determined upon power up and enabling of the drive. Once the initial position is recognized, the drive can commutate off of the position sensor, which provides significantly higher resolution feedback than the digital HEDs. This allows the motor to be sinusoidally commutated. Sinusoidal commutation provides a smoother switching sequence resulting in less disturbances and less heat.

Another method of sinusoidal commutation is through the use of analog Hall effect devices. Analog Halls produce a sinusoidal signal as they pass over the magnetic poles of the magnet track. Analog Halls have also been used as an inexpensive method of providing positional feedback as well as commutation feedback. However, these devices are susceptible to picking up noise which can affect commutation – which in turn, affects smoothness of travel.

In some applications, HEDs are not desired – either from a cost savings standpoint, reduced wiring / component count, or other application specific standpoint. However, the servo drive must still be able to recognize the position of the motor forcer. In this case, **automatic commutation** can be achieved with a properly equipped servo drive. **Parker's Compax3** drive/control has an “auto-commutation with test movement” function that automatically establishes the commutation angle. In this system, the Compax3 applies a test signal which induces small movements in the motor upon power up. The physical size of these movements can be quite small – as small as 10 electrical degrees (less than 2 mm on many linear motors), so there is no need to worry about the motor “*jumping*.” In addition, the test signals are “softened” such that system jerk is minimized.

#### 4.2 Positional Feedback

There are a variety of methods to provide linear positional feedback to the motion controller. There are analog transducers, rack-and-pinion style potentiometers, and laser interferometers, to name a few. Each has its own level of accuracy and cost. But far and away the most popular feedback device for linear motor positioning systems is the linear encoder.

Most linear encoders provide an incremental pulse train that provides discrete “counts” back to the motion controller as the encoder “read head” moves along a “linear scale.” Typically, the read head is mounted close to the load and the linear scale is applied to the positioner base. There are two popular styles of linear encoders – optical and magnetic.

Optical encoders use reflected light scanning techniques to provide feedback with extremely high resolution and accuracy. Optical encoders are capable of providing feedback in the nanometer resolutions. Magnetic encoders use inductive scanning techniques to offer significantly more economical feedback, but have considerably lower accuracy and resolution. Magnetic encoders can typically offer resolutions down between the 1 to 5 micron range.

A third variation of linear encoder is the Sine encoder. The Sine encoder produces analog sine and cosine signals instead of discrete pulses. Many modern motion controllers have the ability to interpolate these analog signals into extremely fine resolutions. For example, the Compax3 controller can interpolate a 1 Vpp signal into 14 bits, i.e., the sine/cosine signal period is divided into 16,384 counts. A typical pitch period of a Sine encoder is 1mm, thus the resolution can be interpolated down to 62 nm in the controller.

All of these encoders provide incremental positioning information. Hence, it is necessary to establish a *home position* any time positional information is lost by the controller, i.e., power down. In some applications it is necessary to have *absolute feedback* where the actual position of the motor is known immediately and no homing sequence is required. Some encoder manufacturers are now making absolute linear encoders that transfer data using a synchronous serial interface (SSI). Parker's **Aries** family of servo drives support absolute feedback transmitted via SSI. Please contact your Parker representative for further details.



Fig. 17: Parker ACR Controller and Aries Drives

When using linear encoders it is critically important to have proper mounting of the scanner (read) head. Inadequate mounting may cause mechanical resonance effects and errors in the measured position caused by vibration of the sensor head. In this case, the achievable bandwidth of the control loop – and hence, the maximum positioning stiffness – is reduced considerably. In some cases, large gaps of positional information are lost entirely, rendering the system totally inaccurate.

If the linear scale is not aligned straight with the guide bearings, accuracy can be affected in the form of “cosine errors.” (Fig. 18) shows a representation of how linear encoder scale misalignment can cause cosine errors.

The actual distance traveled will be  $L$ , where  $L = L_{enc}(\cos\Theta)$ . The size of the error will be  $error = L_{enc}(1 - \cos\Theta)$ . Thus, it is important to pay attention to the mounting of the read head as well as providing robust attachment and accurate alignment of the linear scale.

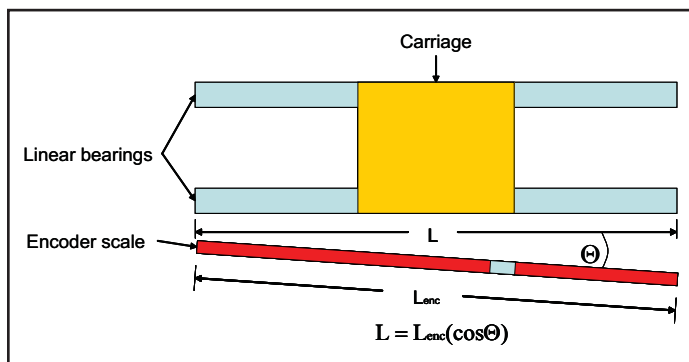

Fig. 18: Cosine errors caused by encoder scale misalignment

### 4.3 Servo Control –

Due to the direct drive nature of linear motors, there are no intermediate mechanical components or gear reductions to absorb external disturbances or shock loading. As a result, these disturbances have a significantly greater impact on the control loop than they would when using other technologies. For this reason, it is extremely important to have a controller with fast trajectory update rates. In addition, it is important to have a controller which allows you manipulate “feedforward” control of speed, acceleration, and jerk. These parameters allow the user to minimize tracking errors during acceleration, deceleration, and during external disturbances.

By defining parameters like jerk within your move profile, the tracking accuracy of highly dynamic moves can be improved, stresses on the mechanical system can be reduced, and excitation of mechanical resonances can be minimized. In addition, payloads that must be handled gently can still have optimized move profiles with the implementation of jerk-limited setpoint generation. Parker’s **ACR** and **Compax3** families of controllers allow optimization of all feedforward parameters and provide extremely fast trajectory update rates for superior control of linear motors.

Another common control challenge of linear motor systems is the control of gantry robots. Unlike belt- and screw-driven gantries where the transmissions of parallel axes can be mechanically connected, linear motor gantries have no mechanical coupling whatsoever. If tight control is not provided between these axes, binding and mechanical damage can occur. Traditional “master – follower” control schemes do not work well with gantries because the follower axis can bind but the master axis will be unable to recognize it.

Parker’s **ACR** series of controllers have a *gantry lock function* which provides skew compensation for gantry systems. By locking the feedback of each axis into the servo loop of the other, perfect coordination between axes is established to prevent binding and mechanical damage.

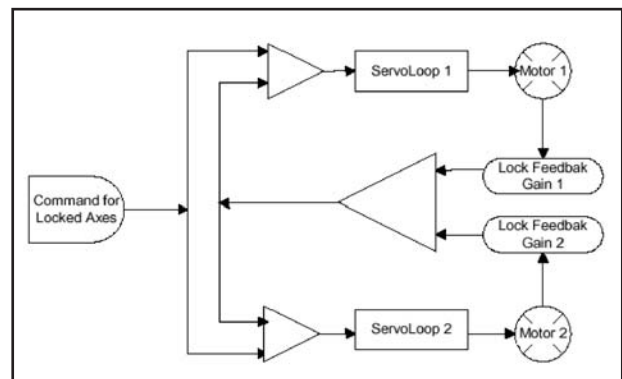

Fig. 19: Parker's ACR Controller Gantry Lock Feature

## 5.0 Packaged Linear Motor Positioners

As we have learned here, there are a lot of elements that affect precision in a linear motor system. Accuracy is affected by the bearing technology, structural stability, mounting and precision of the feedback system, and the capabilities of the controller. In addition, other variables such as mechanical stiffness and vibration can play a large part in the overall error budget of a machine.

As a result, it takes a reasonable amount of expertise to integrate all the components into a precision linear motor system. Many machine builders and laboratory equipment users tend to have expertise in their particular processes rather than in the integration of components. In addition, many systems integrators do not have the time to model, analyze, and implement linear motor designs.

For these reasons, several designers have chosen to purchase pre-packaged, pre-engineered linear motor positioners. By leaving the design and integration work to their vendors, they can deliver cost effective precision motion control solutions to their customers in an extremely short time to market. Components are performance matched for fast response, high acceleration, smooth translation, high velocity, and quick settling time. In addition, positioners can have a variety of flexible connectorization options, cable tracks, and mounting options – including multi-axis compatibility.

*Parker offers a variety of packaged linear motor positioners to fit most any application.*

- Industrial-grade positioners for high force, high motion dynamics, and high precision
- Precision-grade positioners for extremely high positional accuracy
- Miniature precision-grade positioners for lab automation, photonics, electronics and other applications requiring high accuracy in a small form factor



Fig. 20: MX80L Miniature Linear Motor Stage

## 6.0 Linear motors compared against other technologies

It has been well established that linear motors offer the ultimate in high dynamics and high precision. However, many machine builders have cost sensitive budgets and will often look to common rotary-to-linear technologies to solve their positioning needs. This section will take a hard look at these competing technologies and will show the long-term benefits switching to linear motors.

### 6.1 Belt Drives

Belts and pulleys are the workhorses of the automation world. They provide high speeds and reasonable positioning repeatability for an economical component cost. But there are inherent limitations to using belt drives. A belt drive system will typically consist of the following components:

- High tensile strength belt
- Pulleys
- Gearbox, for inertia matching
- Motor and coupling
- Carriage attached to belt
- Roller bearings or slider element

All the torsional windup, backlash, and belt stretching of these components contribute to inaccuracies in the system. Typical repeatability of a belt drive system is around  $\pm 0.2$  mm whereas repeatability for a common linear motor system can be  $\pm 1\mu$ . Even then, the belts must be optimally tensioned and the bearings preloaded. Also, the feedback is connected to the motor and not the load. This contributes to even further inaccuracies in the system.

Additionally, all of these components are “spring like” by nature and cause ringing and delays in settling time. So while belt drive systems can operate at high speeds, they can be difficult to tune for dampening and quick settling. This problem only gets worse at longer lengths, as belts tend to sag the longer they have to span. Eventually, the belt drives become limited in how long they can travel due to the unavoidable sag.

Finally, belt-driven systems can be maintenance intensive. Belts can lose tensioning over time and even skip teeth. Sliding bearings can break down. Couplings can slip or be misaligned. All of these problems force the user to shut down valuable production time in order to maintain the actuator.

Linear motors, by their direct-drive nature, are virtually maintenance free. As long as the bearings are properly lubricated, there is little else to do in order to maintain the positioner. Because all of the mechanical transmission components are gone, linear motor positioners do not suffer from torsional windup, backlash, belt stretch, or settling problems. They are extremely responsive and settle extraordinarily quick. They can match or exceed the acceleration and speed characteristics of a belt drive while positioning far more accurately. Finally, there are no limitations as to how long a linear motor travels. The dynamic performance stays exactly the same, no matter what the distance traversed.

## 6.2 Screw Drives

Screw driven positioning systems are very common for relatively high-precision positioning applications. They are cost-effective and offer varying degrees of precision depending on the needs of the application. A screw-driven system typically consists of the following components:

- Ballscrew or leadscrew that is precision ground or rolled
- Ball nut or sliding nut
- Motor
- Motor block and coupling
- Carriage
- Linear guide – typically square rail, cross roller, or round rail

Leadscrews are typically inefficient, less than 50% in most cases. While they are cost effective, the nut tends to wear due to friction. In addition, the accuracy and repeatability can suffer with leadscrews as most are not precision ground. Ballscrews, approaching 90% efficiency, come in precision ground or rolled packages. However, they still wear over time, suffer from torsional windup, and have a tendency to exhibit backlash. These problems factor into lost precision and slower settling times. In both cases, speeds are limited by the thread pitch and the length of the screw. As screws become longer, they tend to “whip” at higher speeds. Thus, they come nowhere near the speed and acceleration capabilities of linear motors. Eventually, there comes a point where screws become so long, they are difficult and unwieldy to manufacture.

Finally, like belt drives, screw-driven systems must be maintained. Eventually nuts wear, couplings slip, and screws need to be replaced - again, shutting down production and costing the user valuable time and money.

Since linear motor positioners have no intermediate mechanical transmissions, they do not suffer from the drawbacks of screw drives. In addition, they are not limited by length or by the dynamic performance related to length. One drawback to linear motors is that they are not inherently sufficient for vertical applications that require braking. Typically, this problem can be overcome by adding a pneumatic, spring-based, or weight-based counterbalance.

## 6.3 Comparing Costs

In most cases, the upfront cost of purchasing a linear motor system will be more expensive than belt- or screw-driven systems. However, in certain cases the cost can be similar or even less. Many machine builders requiring an extra degree of accuracy will buy a precision-ground ballscrew and add linear encoder feedback. Typically, the added cost of these components will drive the overall cost of the positioner to be higher than that of a linear motor system. In addition, improved manufacturing methods and increased volumes are driving down the cost of linear motors. Over time, users will see the price gap close dramatically. Finally, when comparing the overall cost of ownership (factoring in maintenance and down time), linear motors become considerably less expensive.

## 7.0 The Future of Linear Motors

The field of linear motors will develop dynamically in the future. As costs continue to fall and as innovations continue to rise, more and more industries will begin to adopt linear motor technology. Their high dynamics, high precision, and virtually maintenance-free operation will appeal to traditional users of rotary-to-linear transmissions.

In the early days of linear motors, only the high-tech industries like semiconductor and electronics adopted the technology. Eventually, industries like machine tool latched on to the inherent benefits of direct drives and now account for nearly 1/3rd of all linear motor sales. Now we are seeing new markets like material handling, packaging, medical, and food processing begin to switch out the belts, screws, and even pneumatics for linear motors. All of these new customers are beginning to push the technology to a critical mass and widespread acceptance. Indeed, it looks like linear motors will be making a breakthrough impact on the entire world of manufacturing.

# Linear Motors

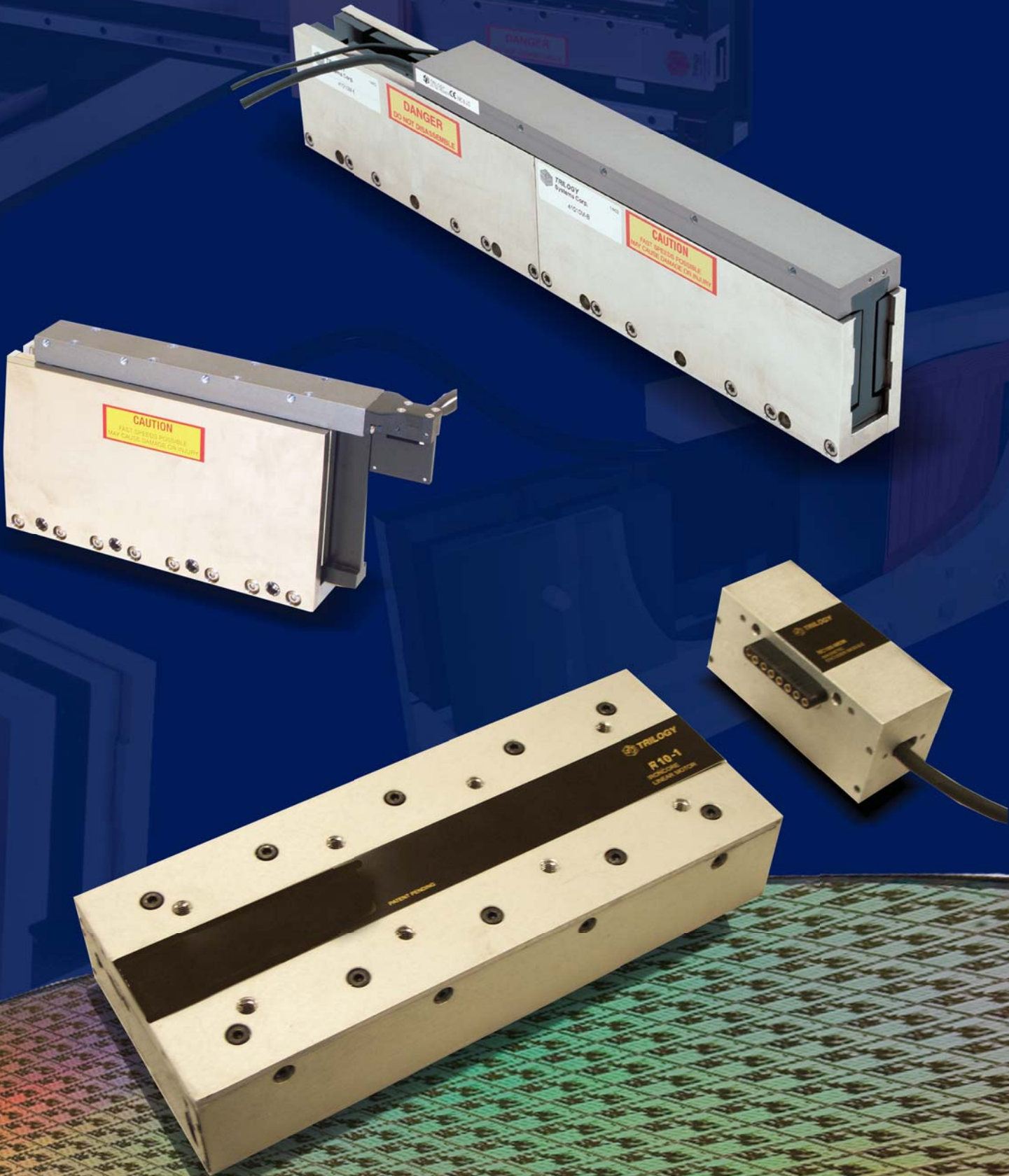

# I-FORCE Ironless linear motors



Parker Trilogy's I-Force ironless linear motors offer high forces and rapid accelerations in a compact package. With forces ranging from 5.5 lbf (24.5 N) - 197.5 lbf (878.6 N) continuous up to 5.5 lbf (24.5 N) - (883 lbf (3928 N) peak, the I-Force family offers a superior combination of performance and size.

The I-Force patented I-beam shape with its overlapping windings allows for a higher power density in a smaller motor, improved heat removal, and added structural stiffness. In addition, the ironless (or air core) linear motor design has no attractive force toward the magnets. This allows for easy installation and zero cogging during motion.

Ultra high-flex cables come standard with I-Force motors. In addition, we offer modular magnet tracks for unrestricted travel length. Incredibly smooth motion, high precision and high force density make the I-Force linear motors an ideal solution for your demanding positioning requirements.

## **Overlapping Windings:**

- Increased force density
- Improved heat dissipation
- Lower temperature rise
- Smaller, less expensive motor

## **No attractive force toward the magnets:**

- Easier/Safer assembly and handling, smoother travel (no cogging)

## **Uses thermally conductive epoxy together with the windings (Patented RE34674):**

- Better heat dissipation

## **Vacuum encapsulation process:**

- Allows motors to be used in high-vacuum environments  
(Rated at  $10^{-6}$  torr, currently used in  $10^{-7}$  torr applications)

## **Modular magnet track:**

- Unrestricted travel length

## **Embedded overtemp thermostat or optional thermistor:**

- Protects windings against overheating

## **Ultra high-flex cables:**

- Longer cable life, good for millions of cycles

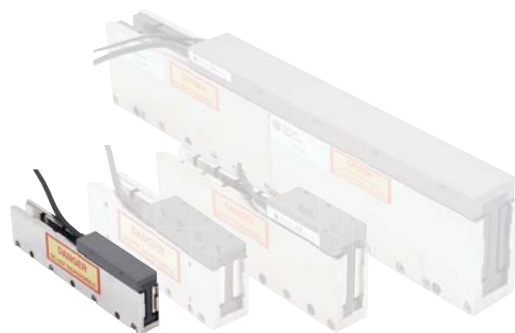

### I FORCE

- Ironless motor, patented, RE34674
- Cross-section: 2.05”H (50mm) x 0.82”W (21mm)
- Peak forces in two sizes to 45lbs (200N), continuous forces to 10lbs (44N)
- Precision ground 3-piece track (110 model)
- Two lengths of modular magnet tracks allow unlimited length of travel
- Single-piece magnet tracks to 36” length
- Prealigned imbedded digital Hall effect devices
- Internal thermal cutout switch protects coil

### PERFORMANCE

MOTOR MODEL		110-1	110-2
Peak Force	N	108.5	202.5
	lb	24.4	45.5
Continuous Force	N	24.5	45.4
	lb	5.5	10.2
Peak Power	W	938	1641
Continuous Power	W	47	82

### ELECTRICAL

MOTOR MODEL		110-1			110-2		
WIRING TYPE	UNITS	S-Series	P-Parallel	T-Triple	S-Series	P-Parallel	T-Triple
Peak Current	A <sub>pk sine</sub>	15.9	31.8	47.7	14.8	29.6	44.4
	(RMS)	11.2	22.5	33.7	10.4	20.9	31.4
Continuous Current	A <sub>pk sine</sub>	3.6	7.2	10.8	3.3	6.6	9.9
	(RMS)	2.5	5.1	7.6	2.3	4.7	7.0
Force Constant	N/A peak	6.8	3.4	2.3	13.7	6.8	4.6
	lb/A peak	1.5	0.8	0.5	3.1	1.5	1.0
Back EMF	V/m/s	7.9	3.9	2.6	15.7	7.9	5.2
	V/in/s	0.20	0.10	0.07	0.40	0.20	0.13
Resistance 25°C, phase to phase	ohms	3.8	1.0	0.4	7.6	1.9	1.0
Inductance, phase to phase	mH	1.0	0.3	0.1	2.0	0.5	0.2
Electrical Time Constant	ms	0.3	0.3	0.3	0.3	0.3	0.3
Motor Constant	N/W	3.56	3.56	3.56	5.02	5.02	5.02
	lb/W	0.80	0.80	0.80	1.13	1.13	1.13
Max Terminal Voltage	VDC	330	330	330	330	330	330

### THERMAL

MOTOR MODEL		110-1	110-2
Thermal Resistance Wind-Amb	degC / W	1.59	0.92
Thermal Time Constant	min	3.2	3.2
Maximum Winding Temperature	°C	100	100

### MECHANICAL

MOTOR MODEL		110-1	110-2
Coil Weight	kg	0.12	0.22
	lb	0.27	0.48
Coil Length	mm	81.3	142.2
	in	3.20	5.60
Attractive Force	N	0	0
	lbf	0	0
Electrical Cycle Length	mm	60.96	60.96
	in	2.40	2.40



**MODULAR  
11007M  
11009M**

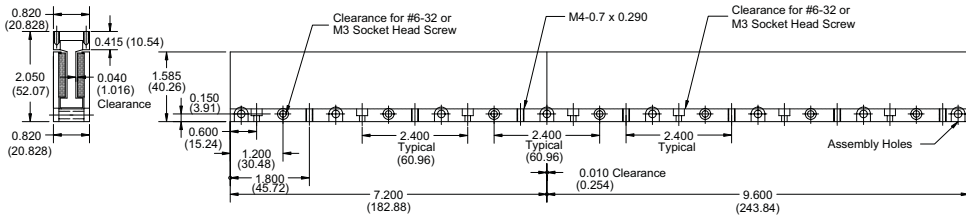

**Incremental Length:**  
2.4in/60.96mm  
**Minimum Length:**  
2.4in/60.96mm  
**Maximum Length:  
(For Single Piece)**  
36in/914.40mm  
**Weight/Foot:**  
2.66lbs/ft

**SINGLE PIECE  
110XXM1**

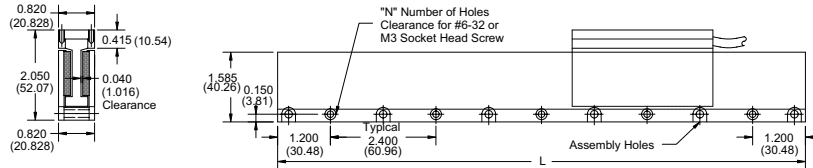

**Incremental Length:**  
2.4in/60.96mm  
**Minimum Length:**  
2.4in/60.96mm  
**Maximum Length:  
(For Single Piece)**  
36in/914.90mm  
**Weight/Foot:**  
2.66lbs/ft

**SINGLE PIECE  
110XXS**

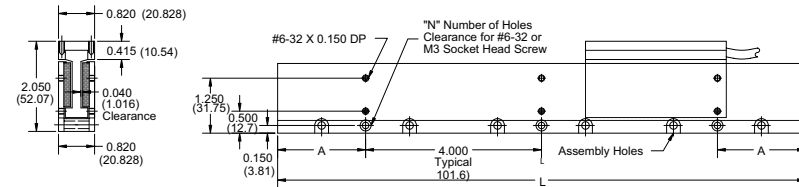

**Incremental Length:**  
1.2in/30.48mm  
**Minimum Length:**  
8.4in/213.4mm  
**Maximum Length:  
(For Single Piece)**  
36in/914.90mm  
**Weight/Foot:**  
2.66lbs/ft

**(A) ENGLISH TOP MOUNTING**

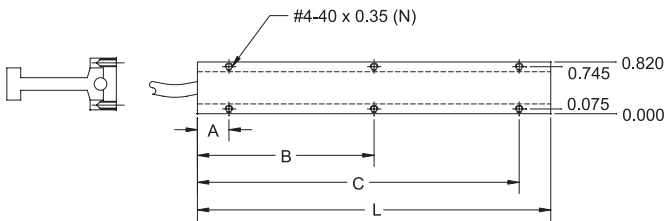

**(B) ENGLISH SIDE MOUNTING**

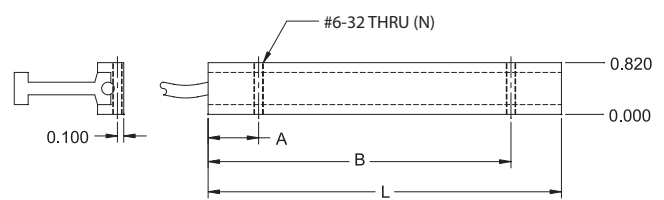

COIL SIZE (inches)	L	N	A	B	C
110-1A	3.20	4	0.50	2.70	---
110-2A	5.60	6	0.50	2.80	5.10

COIL SIZE (inches)	L	N	A	B
110-1B	3.20	2	0.80	2.40
110-2B	5.60	2	0.80	4.80

**(M) METRIC TOP MOUNTING**

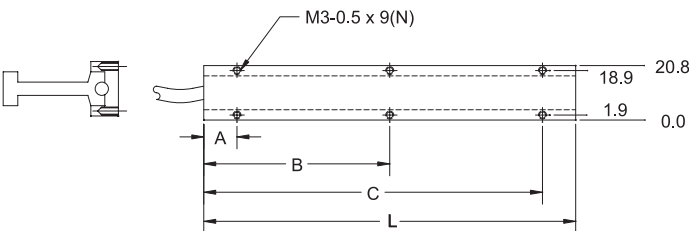

**(N) METRIC SIDE MOUNTING**

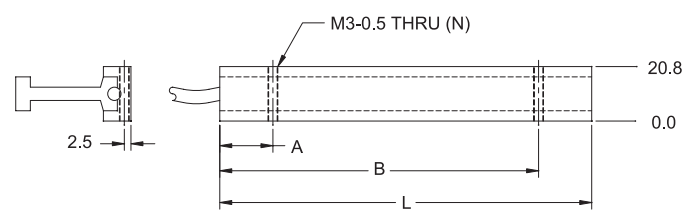

COIL SIZE (mm)	L	N	A	B	C
110-1M	81.3	4	12.7	68.6	---
110-2M	142.2	6	12.7	71.1	129.5

COIL SIZE (mm)	L	N	A	B
110-1N	81.3	2	20.3	60.9
110-2N	142.2	2	20.3	121.9



MODULAR TRACK			
LENGTH In Inches	LENGTH In mm	QUANTITY 11007M 11507M	QUANTITY 11009M 11509M
7.2	182.9	1	0
9.6	243.8	0	1
12.0	304.8	0	0
14.4	365.8	2	0
16.8	426.7	1	1
19.2	487.7	0	2
21.6	548.6	3	0
24.0	609.6	2	1
26.4	670.6	1	2
28.8	731.5	0	3
31.2	792.5	3	1
33.6	853.4	2	2
36.0	914.4	1	3
38.4	975.4	0	4
40.8	1036.3	3	2
43.2	1097.3	2	3
45.6	1158.2	1	4
48.0	1219.2	0	5
50.4	1280.2	3	3
52.8	1341.1	2	4
55.2	1402.1	1	5
57.6	1463.0	0	6
60.0	1524.0	3	4
62.4	1585.0	2	5
64.8	1645.9	1	6
67.2	1706.9	0	7
69.6	1767.8	3	5
72.0	1828.8	2	6

\*Please note that 72.0 inches is NOT the maximum length for modular tracks.

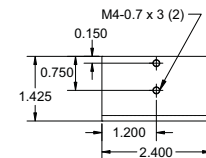

P/N 11502M



10xxS							
P/N	110xx	S	L (in)	L (mm)	A	mm	N
11008	S		8.4	205.8	0.20	5.08	3
11009	S		9.6	235.2	0.80	20.32	3
11010	S		10.8	264.6	1.40	35.56	3
11012	S		12.0	294.0	2.00	50.80	3
11013	S		13.2	323.4	2.60	66.04	3
11014	S		14.4	352.8	3.20	81.28	3
11015	S		15.6	382.2	3.80	96.52	3
11016	S		16.8	411.6	0.40	10.16	5
11018	S		18.0	441.0	1.00	25.40	5
11019	S		19.2	470.4	1.60	40.64	5
11020	S		20.4	499.8	2.20	55.88	5
11021	S		21.6	529.2	2.80	71.12	5
11022	S		22.8	558.6	3.40	86.36	5
11024	S		24.0	588.0	4.00	101.60	5
11025	S		25.2	617.4	0.60	15.24	7
11026	S		26.4	646.8	1.20	30.48	7
11027	S		27.6	676.2	1.80	45.72	7
11028	S		28.8	705.6	2.40	60.96	7
11030	S		30.0	735.0	3.00	76.20	7
11031	S		31.2	764.4	3.60	91.44	7
11032	S		32.4	793.8	0.20	5.08	9
11033	S		33.6	823.2	0.80	20.32	9
11034	S		34.8	852.6	1.40	35.56	9
11036	S		36.0	882.0	2.00	50.80	9

SINGLE PIECE 110xxM					
P/N	110xx	M	L (in)	L (mm)	N
11002	M		2.4	60.96	1
11004	M		4.8	121.92	2
11007	M		7.2	182.88	3
11009	M		9.6	243.84	4
11012	M		12.0	304.80	5
11014	M		14.4	365.76	6
11016	M		16.8	426.72	7
11019	M		19.2	487.68	8
11021	M		21.6	548.64	9
11024	M		24.0	609.60	10
11026	M		26.4	670.56	11
11028	M		28.8	731.52	12
11031	M		31.2	792.48	13
11033	M		33.6	853.44	14
11036	M		36.0	914.40	15



**WDO**

WYE wound with Thermostat  
Digital Hall Effect Devices  
Single Cable: THF10

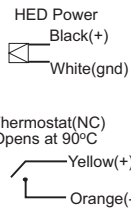
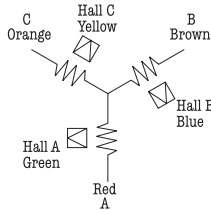

**Hall Effect Devices**  
Symmetrical Response  
4.5V to 18 V Operation  
Open Collector Output  
I<sub>OUT</sub> Continuous 15 mA

**WD1**

Delta wound with Thermistor  
Single Cable: THF08

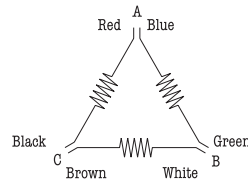

Orange  
Thermistor Omega 44004  
2.2 kOhms Resistance @ 25°C  
Yellow

$$\frac{1}{T} = A + B(\text{LOG}_e R) + C(\text{LOG}_e R)^2$$

Where T = °Kelvin; R = Resistance; A, B, C = fitting constants  
A=1.4626 E-3 B=2.4024 E-4 C=8.0353 E-8

**WD2**

Delta wound with Thermostat  
Single Cable: THF08

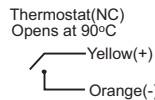
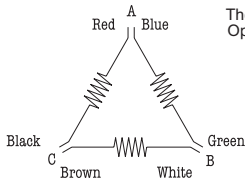

**WD3**

Delta wound with Thermostat  
Digital Hall Effect Devices  
Single Cable: THF10

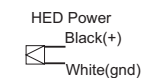
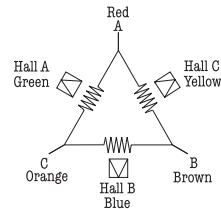

**Hall Effect Devices**  
Symmetrical Response  
4.5V to 18 V Operation  
Open Collector Output  
I<sub>OUT</sub> Continuous 15 mA

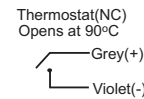

**WD4**

Delta wound with Thermistor  
Digital Hall Effect Devices  
Single Cable: THF10

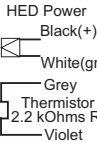
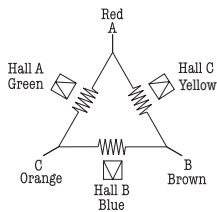

**Hall Effect Devices**  
Symmetrical Response  
4.5V to 18 V Operation  
Open Collector Output  
I<sub>OUT</sub> Continuous 15 mA

$$\frac{1}{T} = A + B(\text{LOG}_e R) + C(\text{LOG}_e R)^2$$

Where T = °Kelvin; R = Resistance; A, B, C = fitting constants  
A=1.4626 E-3 B=2.4024 E-4 C=8.0353 E-8

**NOTES**

1. Peak force and current based on 5% duty cycle and one second duration.
2. Continuous force and current based on coil winding temperature maintained at 100°C.
3. Force constant is peak of resistive force produced by 1.0 amp thru one motor lead and 0.5 amps thru other two leads. Also, Back EMF (V/in/sec) \* 7.665 = Force constant (lb/amp).
4. Motor resistance measured between any two motor leads with motor connected in Delta winding at 25°C. For temperature at 100°C, multiply resistance by 1.295 (75°C rise \* 0.393%/°C)
5. Back EMF measured between any two motor leads while moving at constant velocity. Value is amplitude or 0-Peak of sine wave produced.
6. Motor inductance measured using 1Kz with the motor in the magnetic field.
7. Electrical Time Constant is time it takes for motor value to reach 63% of its final current after a step change in voltage.

8. Thermal Time Constant is time it takes for motor temperature to reach 63% of its final value after a step change in power.
9. Thermal Resistance is the number of degrees (Celsius) of temperature rise in the winding per watt of power dissipated. Determined experimentally.
10. Motor Constant is a measure of efficiency. Calculated by dividing the force constant by the square root of the motor resistance at maximum operating temperature.
11. Electrical Cycle Length is distance coil must travel to complete 360° electrical cycle.
12. Use TIPS sizing software for the most accurate estimate of coil temperature for a particular motion profile.
13. Motors available with nickel plating or black epoxy coating on magnets. Track part number modified with -N or -B at end. Must be specified at time of order.



### I-FORCE

- Ironless motor, patented, RE34674
- Cross-section: 2.25”H (57.1mm) x 1.25”W (31.7mm)
- Peak forces in four sizes to 110lbs (494), continuous forces to 24.8lb (104.5N)
- Precision ground 3-piece track (210 model)
- Two lengths of modular magnet tracks allow unlimited length of travel
- Prealigned imbedded digital HEDs, also available in separate cable from motor leads
- Internal air cooling manifold standard
- Internal thermal cutout switch protects coil

### PERFORMANCE

MOTOR MODEL		210-1	210-2	210-3	210-4
Peak Force	N	137.0	255.8	375.0	494.2
	lb	30.8	57.5	84.3	111.1
Continuous Force	N	30.7	57.4	84.1	110.3
	lb	6.9	12.9	18.9	24.8
Peak Power	W	905	1583	2261	2940
Continuous Power	W	45	79	113	147

### ELECTRICAL

MOTOR MODEL		210-1			210-2			210-3			210-4		
WIRING TYPE	UNITS	S-Series	P-Parallel	T-Triple	S-Series	P-Parallel	T-Triple	S-Series	P-Parallel	T-Triple	S-Series	P-Parallel	T-Triple
Peak Current	A <sub>pk sine</sub>	12.6	25.2	37.8	11.8	23.6	35.4	11.5	23	34.5	11.3	22.6	33.9
	(RMS)	8.9	17.8	26.7	8.3	16.7	25.0	8.1	16.3	24.4	8.0	16.0	23.9
Continuous Current	A <sub>pk sine</sub>	2.8	5.6	8.4	2.6	5.2	7.8	2.6	5.2	7.8	2.5	5.0	7.5
	(RMS)	1.9	3.9	5.9	1.8	3.7	5.5	1.8	3.7	5.5	1.8	3.5	5.3
Force Constant	N/A peak	10.9	5.4	3.6	21.8	10.9	7.3	32.7	16.4	10.9	43.6	21.8	14.5
	lb/A peak	2.5	1.2	0.8	4.9	2.5	1.6	7.4	3.7	2.5	9.8	4.9	3.3
Back EMF	V/m/s	12.6	6.3	4.2	25.2	12.6	8.4	37.8	18.9	12.6	50.4	25.2	16.8
	V/in/s	0.32	0.16	0.11	0.64	0.32	0.21	0.96	0.48	0.32	1.28	0.64	0.43
Resistance 25°C, phase to phase	ohms	5.9	1.5	0.7	11.8	3.0	1.3	17.7	4.4	2.0	23.6	5.9	2.6
Inductance, phase to phase	mH	2.4	0.6	0.3	4.8	1.2	0.5	7.2	1.8	0.8	9.6	2.4	1.1
Electrical Time Constant	ms	0.4	0.4	0.4	0.4	0.4	0.4	0.4	0.4	0.4	0.4	0.4	0.4
Motor Constant	N/W	4.54	4.54	4.54	6.45	6.45	6.45	7.87	7.87	7.87	9.12	9.12	9.12
	lb/W	1.02	1.02	1.02	1.45	1.45	1.45	1.77	1.77	1.77	2.05	2.05	2.05
Max Terminal Voltage	VDC	330	330	330	330	330	330	330	330	330	330	330	330

### THERMAL

MOTOR MODEL		210-1	210-2	210-3	210-4
Thermal Resistance Wind-Amb	degC / W	1.67	0.94	0.66	0.51
Thermal Time Constant	min	4.3	4.3	4.3	4.3
Maximum Winding Temperature	°C	100	100	100	100

### MECHANICAL

MOTOR MODEL		210-1	210-2	210-3	210-4
Coil Weight	kg	0.16	0.27	0.39	0.51
	lb	0.35	0.60	0.86	1.12
Coil Length	mm	81.3	142.2	203.2	264.2
	in	3.2	5.6	8.0	10.4
Attractive Force	N	0	0	0	0
	lbf	0	0	0	0
Electrical Cycle Length	mm	60.96	60.96	60.96	60.96
	in	2.4	2.4	2.4	2.4



**MODULAR  
21007M  
21009M**

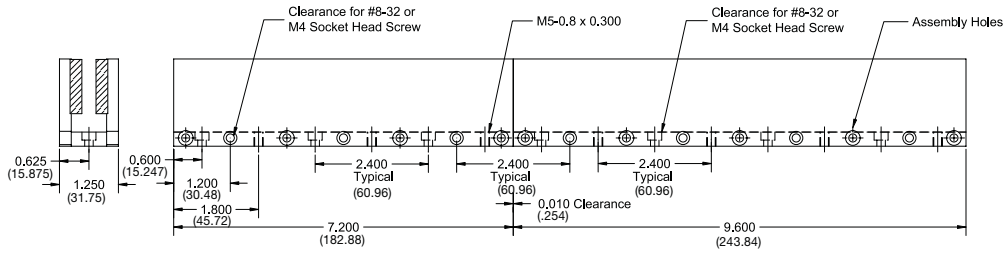

**Incremental Length:**  
2.4in/60.96mm

**Minimum Length:**  
2.4in/60.96mm

**Maximum Length:  
(For Single Piece)**  
48in/1219.2mm

**Weight/Foot:**  
5.50lbs/ft

**SINGLE PIECE  
210xxM1**

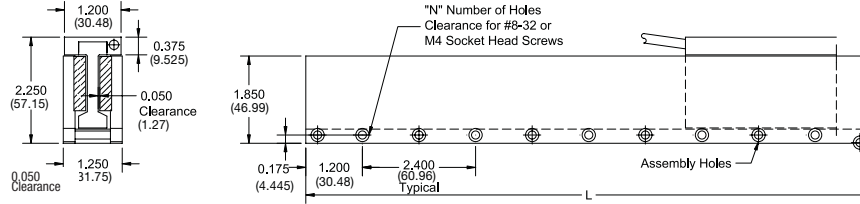

**Incremental Length:**  
2.4in/60.96mm

**Minimum Length:**  
2.4in/60.96mm

**Maximum Length:  
(For Single Piece)**  
48in/1219.2mm

**Weight/Foot:**  
5.50lbs/ft

**SINGLE PIECE  
210xxS**

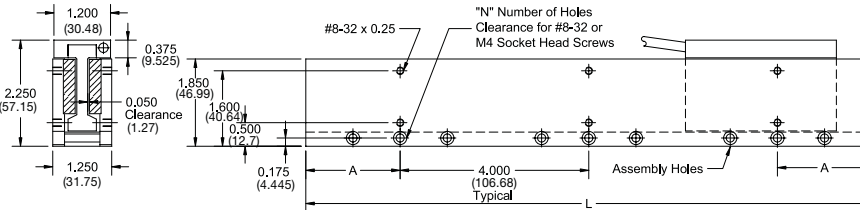

**Incremental Length:**  
1.2in/30.48mm

**Minimum Length:**  
8.4in/213.4mm

**Maximum Length:  
(For Single Piece)**  
48in/1219.2mm

**Weight/Foot:**  
5.50lbs/ft

**(A) ENGLISH TOP MOUNTING**

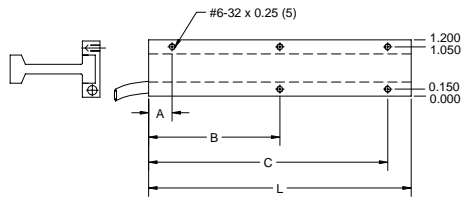

**(B) ENGLISH SIDE MOUNTING**

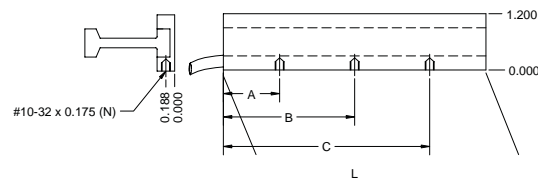

COIL SIZE (inches)	L	N	A	B	C
210-1A	3.20	5	0.50	1.60	2.70
210-2A	5.60	5	0.50	2.80	5.10
210-3A	8.00	5	0.50	4.00	7.50
210-4A	10.40	5	0.50	5.20	9.90

COIL SIZE (inches)	L	N	A	B	C
210-1B	3.20	2	1.950	2.950	---
210-2B	5.60	2	1.625	3.975	---
210-3B	8.00	3	2.438	4.000	5.562
210-4B	10.40	3	2.600	5.200	7.800

**(M) METRIC TOP MOUNTING**

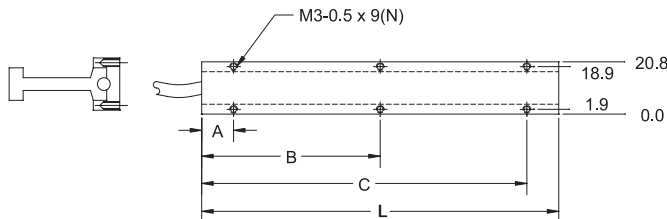

**(N) METRIC SIDE MOUNTING**

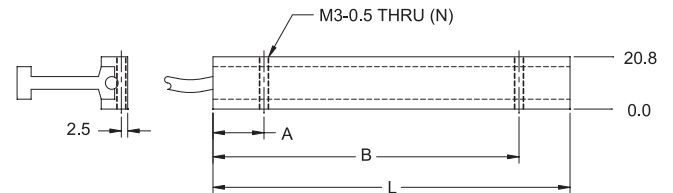

COIL SIZE (mm)	L	N	A	B	C
210-1M	81.3	5	12.7	40.6	68.6
210-2M	142.2	5	12.7	71.1	129.5
210-3M	203.2	5	12.7	101.6	190.5
210-4M	264.2	5	12.7	132.1	251.5

COIL SIZE (mm)	L	N	A	B	C
210-1N	81.3	2	49.5	74.9	---
210-2N	142.2	2	41.3	101.0	---
210-3N	203.2	3	61.9	101.6	141.3
210-4N	264.2	3	66.0	132.1	198.1



MODULAR TRACK			
LENGTH In Inches	LENGTH In mm	QUANTITY 21007M 21507M	QUANTITY 21009M 21509M
7.2	182.9	1	0
9.6	243.8	0	1
12.0	304.8	0	0
14.4	365.8	2	0
16.8	426.7	1	1
19.2	487.7	0	2
21.6	548.6	3	0
24.0	609.6	2	1
26.4	670.6	1	2
28.8	731.5	0	3
31.2	792.5	3	1
33.6	853.4	2	2
36.0	914.4	1	3
38.4	975.4	0	4
40.8	1036.3	3	2
43.2	1097.3	2	3
45.6	1158.3	1	4
48.0	1219.2	0	5
50.4	1280.2	3	3
52.8	1341.1	2	4
55.2	1402.1	1	5
57.6	1463.0	0	6
60.0	1524.0	3	4
62.4	1585.0	2	5
64.8	1645.9	1	6
67.2	1706.9	0	7
69.6	1767.8	3	5
72.0	1828.8	2	6

\*Please note that 72.0 inches is NOT the maximum length for modular tracks.

210xxS							
P/N	210xx	S	L (in)	L (mm)	A	mm	N
21008	S	8.4	205.8	0.20	5.08	3	
21009	S	9.6	235.2	0.80	20.32	3	
21010	S	10.8	264.6	1.40	35.56	3	
21012	S	12.0	294.0	2.00	50.80	3	
21013	S	13.2	323.4	2.60	66.04	3	
21014	S	14.4	352.8	3.20	81.28	3	
21015	S	15.6	382.2	3.80	96.52	3	
21016	S	16.8	411.6	0.40	10.16	5	
21018	S	18.0	441.0	1.00	25.40	5	
21019	S	19.2	470.4	1.60	40.64	5	
21020	S	20.4	499.8	2.20	55.88	5	
21021	S	21.6	529.2	2.80	71.12	5	
21022	S	22.8	558.6	3.40	86.36	5	
21024	S	24.0	588.0	4.00	101.60	5	
21025	S	25.2	617.4	0.60	15.24	7	
21026	S	26.4	646.8	1.20	30.48	7	
21027	S	27.6	676.2	1.80	45.72	7	
21028	S	28.8	705.6	2.40	60.96	7	
21030	S	30.0	735.0	3.00	76.20	7	
21031	S	31.2	764.4	3.60	91.44	7	
21032	S	32.4	793.8	0.20	5.08	9	
21033	S	33.6	823.2	0.80	20.32	9	
21034	S	34.8	842.6	1.40	35.56	9	
21036	S	36.0	882.0	2.00	50.80	9	
21037	S	37.2	911.4	2.60	66.04	9	
21038	S	38.4	940.8	3.20	81.28	9	
21039	S	39.6	970.2	3.80	96.52	9	
21040	S	40.8	999.6	0.40	10.16	11	
21042	S	42.0	1029.0	1.00	25.40	11	
21043	S	43.2	1058.4	1.60	40.64	11	
21044	S	44.4	1127.8	2.20	55.88	11	
21045	S	45.6	1158.2	2.80	71.12	11	
21046	S	46.8	1188.7	3.40	86.36	11	
21048	S	48.0	1219.2	4.00	101.6	11	

210xxM1					
P/N	210xx	M1	L (in)	L (mm)	N
21002	M1	2.4	60.96	1	
21004	M1	4.8	121.62	2	
21007	M1	7.2	182.88	3	
21009	M1	9.6	243.84	4	
21012	M1	12.0	304.80	5	
21014	M1	14.4	365.76	6	
21016	M1	16.8	426.72	7	
21019	M1	19.2	487.68	8	
21021	M1	21.6	548.64	9	
21024	M1	24.0	609.60	10	
21026	M1	26.4	670.56	11	
21028	M1	28.8	731.52	12	
21031	M1	31.2	792.48	13	
21033	M1	33.6	853.44	14	
21036	M1	36.0	914.40	15	
21038	M1	38.4	975.36	16	
21040	M1	40.8	1036.32	17	
21043	M1	43.2	1097.28	18	
21045M1		45.6	1158.24	19	
21048	M1	48.0	1219.20	20	

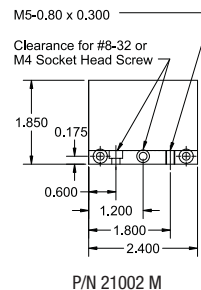

SINGLE PIECE 210xxM					
P/N	210xx	M	L (in)	L (mm)	N
21002	M	2.4	60.96	1	
21004	M	4.8	121.62	2	
21007	M	7.2	182.88	3	
21009	M	9.6	243.84	4	
21012	M	12.0	304.80	5	
21014	M	14.4	365.76	6	
21016	M	16.8	426.72	7	
21019	M	19.2	487.68	8	
21021	M	21.6	548.64	9	
21024	M	24.0	609.60	10	
21026	M	26.4	670.56	11	
21028	M	28.8	731.52	12	
21031	M	31.2	792.48	13	
21033	M	33.6	853.44	14	
21036	M	36.0	914.40	15	
21038	M	38.4	975.36	16	
21040	M	40.8	1036.32	17	
21043	M	43.2	1097.28	18	
21045	M	45.6	1158.24	19	
21048	M	48.0	1219.20	20	



**WD1**

Delta wound with Thermistor  
Single Cable: THF08

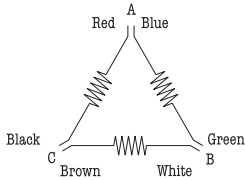

Orange  
Thermistor Omega 44004  
2.2 kOhms Resistance @ 25°C  
Yellow

$$\frac{1}{T} = A + B(\text{LOG}_e R) + C(\text{LOG}_e R)^3$$

Where T = °Kelvin; R = Resistance; A, B, C = fitting constants  
A=1.4626 E-3 B=2.4024 E-4 C=8.0353 E-8

**WD2**

Delta wound with Thermostat  
Single Cable: THF08

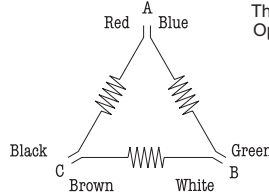

Thermostat(NC)  
Opens at 90°C  
Yellow(+)  
Orange(-)

**WD3**

Delta wound with Thermostat  
Digital Hall Effect Devices  
Single Cable: THF10

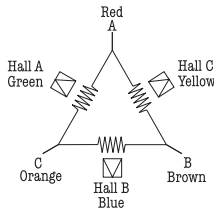

HED Power  
Black(+)  
White(gnd)

Thermostat(NC)  
Opens at 90°C  
Grey(+)  
Violet(-)

Hall Effect Devices  
Symmetrical Response  
4.5V to 18 V Operation  
Open Collector Output  
I<sub>OUT</sub> Continuous 15 mA

**WD4**

Delta wound with Thermistor  
Digital Hall Effect Devices  
Single Cable: THF10

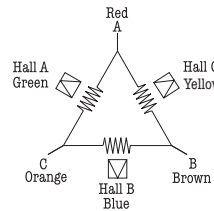

HED Power  
Black(+)  
White(gnd)  
Grey  
Thermistor Omega 44004  
2.2 kOhms Resistance @ 25°C  
Violet

Hall Effect Devices  
Symmetrical Response  
4.5V to 18 V Operation  
Open Collector Output  
I<sub>OUT</sub> Continuous 15 mA

$$\frac{1}{T} = A + B(\text{LOG}_e R) + C(\text{LOG}_e R)^3$$

Where T = °Kelvin; R = Resistance; A, B, C = fitting constants  
A=1.4626 E-3 B=2.4024 E-4 C=8.0353 E-8

**WD7\***

Delta wound with Thermostat  
Digital Hall Effect Devices  
Dual Cables: THF06 and THF08

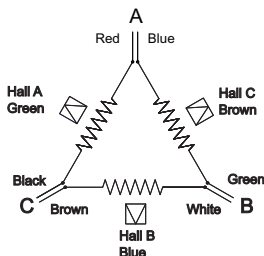

Thermostat  
(Normally Closed)  
Opens at 90C  
Orange (+)  
Yellow (-)

HED Power  
Black (+)  
White (Gnd)

HALL EFFECT DEVICES  
Symmetrical Response  
4.5 to 18 Vdc power  
Open Collector Output  
15ma continuous

\*Preferred Configuration with Parker Drives

**NOTES**

1. Peak force and current based on 5% duty cycle and one second duration.
2. Continuous force and current based on coil winding temperature maintained at 100°C.
3. Force constant is peak of resistive force produced by 1.0 amp thru one motor lead and 0.5 amps thru other two leads. Also, Back EMF (V/in/sec) \* 7.665 = Force constant (lb/amp).
4. Motor resistance measured between any two motor leads with motor connected in Delta winding at 25°C. For temperature at 100°C, multiply resistance by 1.295 (75°C rise \* 0.393%/°C).
5. Back EMF measured between any two motor leads while moving at constant velocity. Value is amplitude or 0-Peak of sine wave produced.
6. Motor inductance measured using 1Kz with the motor in the magnetic field.
7. Electrical Time Constant is time it takes for motor value to reach 63% of its final current after a step change in voltage.

8. Thermal Time Constant is time it takes for motor temperature to reach 63% of its final value after a step change in power.
9. Thermal Resistance is the number of degrees (Celsius) of temperature rise in the winding per watt of power dissipated. Determined experimentally.
10. Motor Constant is a measure of efficiency. Calculated by dividing the force constant by the square root of the motor resistance at maximum operating temperature.
11. Electrical Cycle Length is distance coil must travel to complete 360° electrical cycle.
12. Use TIPS sizing software for the most accurate estimate of coil temperature for a particular motion profile.
13. Motors available with nickel plating or black epoxy coating on magnets. Track part number modified with -N or -B at end. Must be specified at time of order.





### I-FORCE

- Ironless motor, patented, RE34674
- Cross-section: 3.40”H (86.4mm) x 1.35”W (34.3mm)
- Peak forces in two sizes to 263lbs (1170N), continuous forces to 58lbs (262N)
- Precision ground 3-piece track (310 model)
- Two lengths of modular magnet tracks allow unlimited length of travel
- Single-piece magnet tracks to 66” length
- Prealigned embedded digital HEDs, also available in separate cable from motor leads
- Internal air or liquid cooling available
- Internal thermal cutout switch protects coil

### PERFORMANCE

MOTOR MODEL		310-1	310-2	310-3	310-4	310-5	310-6
Peak Force	N	218.9	409.3	600.0	790.0	980.0	1170.0
	lb	49.2	92.0	135.1	177.2	220.3	263.2
Continuous Force	N	49.0	91.6	133.9	176.2	219.3	262.0
	lb	11.0	20.6	30.1	39.6	49.3	58.9
Peak Power	W	1077	1885	2693	3500	4308	5116
Continuous Power	W	54	94	135	179	215	256

### ELECTRICAL

MOTOR MODEL		310-1			310-2			310-3			310-4			310-5			310-6		
WIRING TYPE	UNITS	S	P	T	S	P	T	S	P	T	S	P	T	S	P	T	S	P	T
Peak Current	A pk sine	16.1	32.2	48.3	15.0	30.0	45.0	14.7	29.4	44.1	14.5	29.0	43.5	14.4	28.8	43.2	14.3	28.6	42.9
	(RMS)	11.4	22.8	34.2	10.6	21.2	31.8	10.4	20.8	31.2	10.3	20.5	30.8	10.2	20.4	30.5	10.1	20.2	30.3
Continuous Current	A pk sine	3.6	7.2	10.8	3.4	6.8	10.2	3.3	6.6	9.9	3.2	6.4	9.6	3.2	6.4	9.6	3.2	6.4	9.6
	(RMS)	2.5	5.1	7.6	2.4	4.8	7.2	2.5	4.7	7.0	2.3	4.5	6.8	2.3	4.5	6.8	2.3	4.5	6.8
Force Constant	N/A peak	13.7	6.8	4.6	27.3	13.6	9.1	40.9	20.5	13.6	54.7	27.4	18.2	68.1	34.0	22.7	81.8	40.9	27.3
	lb/A peak	3.1	1.5	1.0	6.1	3.1	2.0	9.2	4.6	3.1	12.3	6.2	4.1	15.3	7.7	5.1	18.4	9.2	6.1
Back EMF	V/m/s	15.7	7.8	5.2	31.5	15.7	10.5	47.2	23.6	15.7	63.0	31.5	21.0	78.7	39.4	26.2	94.5	47.2	31.5
	V/in/s	0.40	0.20	0.13	0.80	0.40	0.27	1.20	0.60	0.40	1.60	0.80	0.53	2.00	1.00	0.67	2.40	1.20	0.80
Resistance 25°C, phase to phase	ohms	4.3	1.1	0.5	8.6	2.2	1.0	12.9	3.2	1.4	17.2	4.3	1.9	21.5	5.4	2.4	25.8	6.5	2.9
Inductance, phase to phase	mH	3.0	0.8	0.3	6.0	1.5	0.7	9.0	2.3	1.0	12.0	3.0	1.3	15.0	3.8	1.7	18.0	4.5	2.0
Electrical Time Constant	ms	0.7	0.7	0.7	0.7	0.7	0.7	0.7	0.7	0.7	0.7	0.7	0.7	0.7	0.7	0.7	0.7	0.7	0.7
Motor Constant	N/W	6.67	6.67	6.67	9.43	9.43	9.43	11.57	11.57	11.57	13.34	13.34	13.34	14.95	14.95	14.95	16.37	16.37	16.37
	lb/W	1.50	1.50	1.50	2.12	2.12	2.12	2.60	2.60	2.60	3.00	3.00	3.00	3.36	3.36	3.36	3.68	3.68	3.68
Max Terminal Voltage	VDC	330	330	330	330	330	330	330	330	330	330	330	330	330	330	330	330	330	330

NOTE: S-Series P-Parallel T-Triple

### THERMAL

MOTOR MODEL		310-1	310-2	310-3	310-4	310-5	310-6
Thermal Resistance Wind-Amb	degC / W	1.39	0.79	0.56	0.43	0.35	0.29
Thermal Time Constant	min	7.5	7.5	7.5	7.5	7.5	7.5
Maximum Winding Temperature	°C	100	100	100	100	100	100

### MECHANICAL

MOTOR MODEL		310-1	310-2	310-3	310-4	310-5	310-6
Coil Weight	kg	0.31	0.55	0.80	1.03	1.27	1.53
	lb	0.69	1.22	1.75	2.27	2.80	3.36
Coil Length	mm	81.3	142.2	203.2	264.2	325.1	386.1
	in	3.2	5.6	8.0	10.4	12.8	15.2
Attractive Force	N	0	0	0	0	0	0
	lbf	0	0	0	0	0	0
Electrical Cycle Length	mm	60.96	60.96	60.96	60.96	60.96	60.96
	in	2.4	2.4	2.4	2.4	2.4	2.4



**MODULAR  
31007M  
31009M**

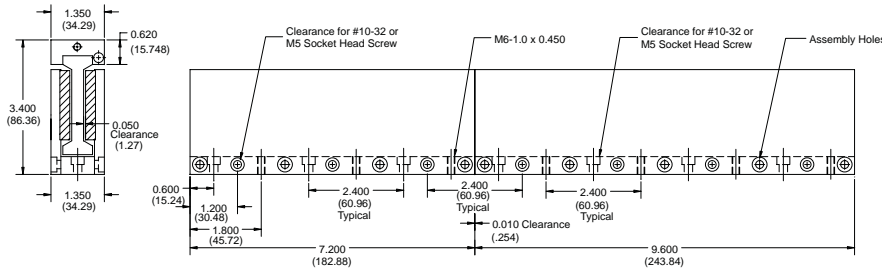

**Incremental Length:**  
2.4in/60.96mm

**Minimum Length:**  
2.4in/60.96mm

**Maximum Length:  
(For Single Piece)**  
64.8in/1645.9mm

**Weight/Foot:**  
8.50lbs/ft

**SINGLE PIECE  
310xxM1**

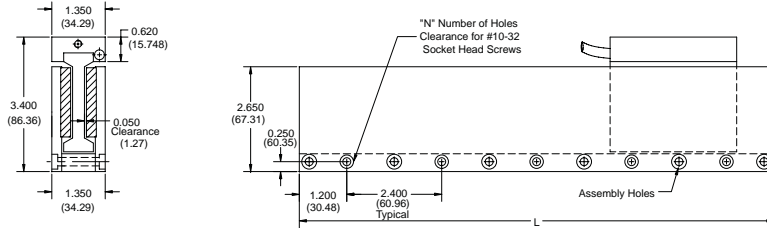

**Incremental Length:**  
2.4in/60.96mm

**Minimum Length:**  
2.4in/60.96mm

**Maximum Length:**  
64.8in/1645.9mm

**Weight/Foot:**  
8.50lbs/ft

**SINGLE PIECE  
310xxS**

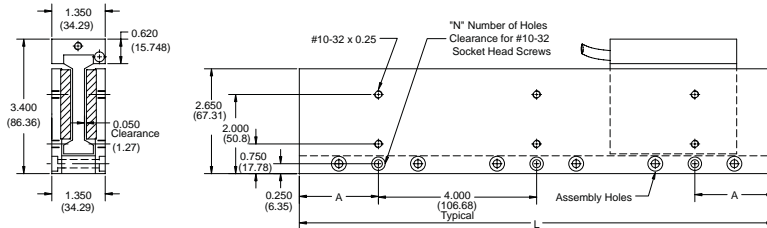

**Incremental Length:**  
1.2in/30.48mm

**Minimum Length:**  
8.4in/213.4mm

**Maximum Length:**  
66in/1676.4mm

**Weight/Foot:**  
8.50lbs/ft

**(A) ENGLISH TOP MOUNTING**

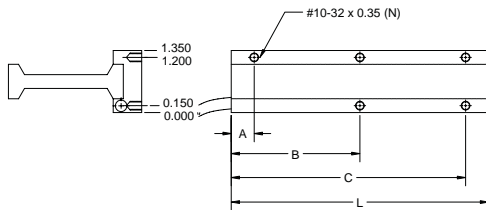

COIL SIZE (inches)	L	N	A	B	C
310-1A	3.20	5	0.50	1.60	2.70
310-2A	5.60	5	0.50	2.80	5.10
310-3A	8.00	5	0.50	4.00	7.50
310-4A	10.40	5	0.50	5.20	9.90
310-5A	12.80	5	0.50	6.40	12.30
310-6A	15.20	5	1.70	7.60	13.50

**(B) ENGLISH SIDE MOUNTING**

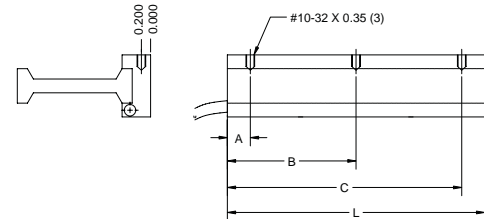

COIL SIZE (inches)	L	N	A	B	C
310-1B	3.20	3	0.50	1.60	2.70
310-2B	5.60	3	0.50	2.80	5.10
310-3B	8.00	3	0.50	4.00	7.50
310-4B	10.40	3	0.50	5.20	9.90
310-5B	12.80	3	0.50	6.40	12.30
310-6B	15.20	3	1.70	7.60	13.50

**(M) METRIC TOP MOUNTING**

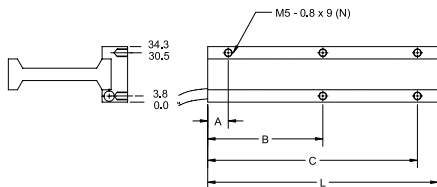

COIL SIZE (mm)	L	N	A	B	C
310-1M	81.3	5	12.7	40.6	68.6
310-2M	141.2	5	12.7	71.1	129.5
310-3M	203.2	5	12.7	101.6	190.5
310-4M	264.2	5	12.7	132.1	251.5
310-5M	325.1	5	12.7	162.6	312.4
310-6M	386.1	5	43.2	193.0	342.9

**(N) METRIC SIDE MOUNTING**

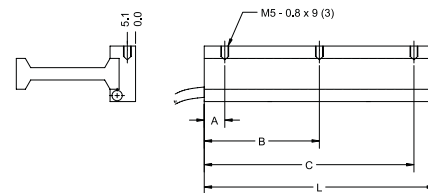

COIL SIZE (mm)	L	N	A	B	C
310-1N	81.3	3	12.7	40.6	68.6
310-2N	141.2	3	12.7	71.1	129.5
310-3N	203.2	3	12.7	101.6	190.5
310-4N	264.2	3	12.7	132.1	251.5
310-5N	325.1	3	12.7	162.6	312.4
310-6N	386.1	3	43.2	193.0	342.9



### MODULAR TRACK

LENGTH In Inches	LENGTH In mm	QUANTITY 31007M 31507M	QUANTITY 31009M 31509M
7.2	182.9	1	0
9.6	243.8	0	1
12.0	304.8	1	0
14.4	365.8	2	0
16.8	426.7	1	1
19.2	487.7	0	2
21.6	548.6	3	0
24.0	609.6	2	1
26.4	670.6	1	2
28.8	731.5	0	3
31.2	792.5	3	1
33.6	853.4	2	2
36.0	914.4	1	3
38.4	975.4	0	4
40.8	1036.3	3	2
43.2	1097.3	2	3
45.6	1158.3	1	4
48.0	1219.2	0	5
50.4	1280.2	3	3
52.8	1341.1	2	4
55.2	1402.1	1	5
57.6	1463.0	0	6
60.0	1524.0	3	4
62.4	1585.0	2	5
64.8	1645.9	1	6
67.2	1706.9	0	7
69.6	1767.8	3	5
72.0	1828.8	2	6

\*Please note that 72.0 inches is NOT the maximum length for modular tracks.

### 310xxS

P/N	310xx	S	L (in)	L (mm)	A	A (mm)	N	P/N	310xx	S	L (in)	L (mm)	A	A (mm)	N
31008	S		8.4	205.8	0.20	5.08	3	31038	S		38.4	940.8	3.20	81.28	9
31009	S		9.6	235.2	0.80	20.32	3	31039	S		39.6	970.2	3.80	96.52	9
31010	S		10.8	264.6	1.40	1.40	3	31040	S		40.8	999.6	0.40	10.16	11
31012	S		12.0	294.0	2.00	50.80	3	31042	S		42.0	1029.0	1.00	25.40	11
31013	S		13.2	323.4	2.60	66.04	3	31043	S		43.2	1058.4	1.60	40.64	11
31014	S		14.4	352.8	3.20	81.28	3	31044	S		44.4	1087.8	2.20	55.88	11
31015	S		15.6	382.2	3.80	96.52	3	31045	S		45.6	1117.2	2.80	71.12	11
31016	S		16.8	411.6	0.40	10.16	5	31046	S		46.8	1146.6	3.40	86.36	11
31018	S		18.0	441.0	1.00	25.40	5	31048	S		48.0	1176.0	4.00	101.60	11
31019	S		19.2	470.4	1.60	40.64	5	31049	S		49.2	1205.4	0.60	15.24	13
31020	S		20.4	499.8	2.20	55.88	5	31050	S		50.4	1234.8	1.20	30.48	13
31021	S		21.6	529.2	2.80	71.12	5	31051	S		51.6	1264.2	1.80	45.72	13
31022	S		22.8	558.6	3.40	86.36	5	31052	S		52.8	1293.6	2.40	60.96	13
31024	S		24.0	588.0	4.00	101.60	5	31054	S		54.0	1323.0	3.00	76.20	13
31025	S		25.2	617.4	0.60	15.24	7	31055	S		55.2	1352.4	3.60	91.44	13
31026	S		26.4	646.8	1.20	30.48	7	31056	S		56.4	1381.8	0.20	5.08	15
31027	S		27.6	676.2	1.80	45.72	7	31057	S		57.6	1411.2	0.80	20.32	15
31028	S		28.8	705.6	2.40	60.96	7	31058	S		58.8	1440.6	1.40	35.56	15
31030	S		30.0	735.0	3.00	76.20	7	31060	S		60.0	1470.0	2.00	50.80	15
31031	S		31.2	764.4	3.60	91.44	7	31061	S		61.2	1499.4	2.60	66.04	15
31032	S		32.4	793.8	0.20	5.08	9	31062	S		62.4	1528.8	3.20	81.28	15
31033	S		33.6	823.2	0.80	20.32	9	31063	S		63.6	1558.2	3.80	96.52	15
31034	S		34.8	852.6	1.40	35.56	9	31064	S		64.8	1587.6	0.40	10.16	17
31036	S		36.0	882.0	2.00	50.80	9	31066	S		66.0	1617.0	1.00	25.40	17
31037	S		37.2	911.4	2.60	66.04	9								

### 310xxM1

P/N	310xx	M1	L (in)	L (mm)	N	P/N	310xx	M1	L (in)	L (mm)	N
31002	M1		2.4	60.96	1	31028	M1		28.8	731.52	12
31004	M1		4.8	121.92	2	31031	M1		31.2	792.48	13
31007	M1		7.2	182.88	3	31033	M1		33.6	853.44	14
31009	M1		9.6	243.84	4	31036	M1		36.0	914.40	15
31012	M1		12.0	304.80	5	31038	M1		38.1	975.36	16
31014	M1		14.4	365.76	6	31040	M1		40.8	1036.32	17
31016	M1		16.8	426.72	7	31043	M1		43.2	1097.28	18
31019	M1		19.2	487.68	8	31045	M1		45.6	1158.20	19
31021	M1		21.6	548.64	9	31048	M1		48.0	1219.20	20
31024	M1		24.0	609.60	10	31050	M1		50.4	1280.16	21
31026	M1		26.4	670.56	11	31052	M1		52.8	1341.12	22
						31055	M1		55.2	1402.08	23
						31057	M1		57.6	1463.04	24
						31060	M1		60.0	1524.00	25
						31062	M1		62.4	1584.96	26
						31064	M1		64.8	1645.92	27

### SINGLE PIECE 310xxM

P/N	310xx	M	L (in)	L (mm)	N
31002	M		2.4	60.96	1
31004	M		4.8	121.92	2
31007	M		7.2	182.88	3
31009	M		9.6	243.84	4
31012	M		12.0	304.80	5
31014	M		14.4	365.76	6
31016	M		16.8	426.72	7
31019	M		19.2	487.68	8
31021	M		21.6	548.64	9
31024	M		24.0	609.60	10
31026	M		26.4	670.56	11
31028	M		28.8	731.52	12
31031	M		31.2	792.48	13
31033	M		33.6	853.44	14
31036	M		36.0	914.40	15
31038	M		38.4	975.36	16
31040	M		40.8	1036.32	17
31043	M		43.2	1097.28	18
31045	M		45.6	1158.24	19
31048	M		48.0	1219.20	20
31050	M		50.4	1280.16	21
31052	M		52.8	1341.12	22
31055	M		55.2	1402.08	23
31057	M		57.6	1463.04	24
31060	M		60.0	1524.00	25
31062	M		62.4	1584.96	26
31064	M		64.8	1645.92	27

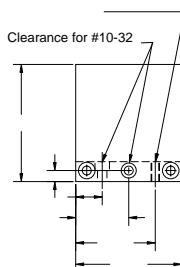

P/N 31002 M



**WD1**

Delta wound with Thermistor  
Single Cable: THF08

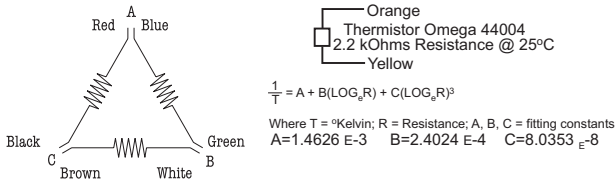

**WD2**

Delta wound with Thermostat  
Single Cable: THF08

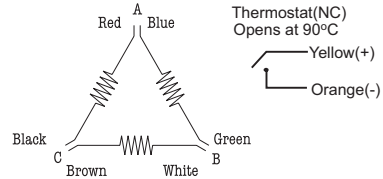

**WD3**

Delta wound with Thermostat  
Digital Hall Effect Devices  
Single Cable: THF10

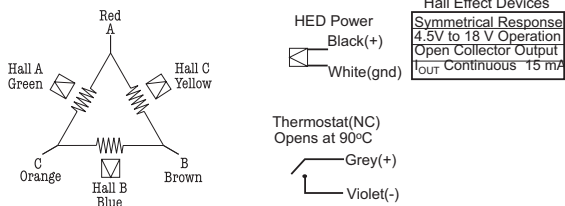

**WD4**

Delta wound with Thermistor  
Digital Hall Effect Devices  
Single Cable: THF10

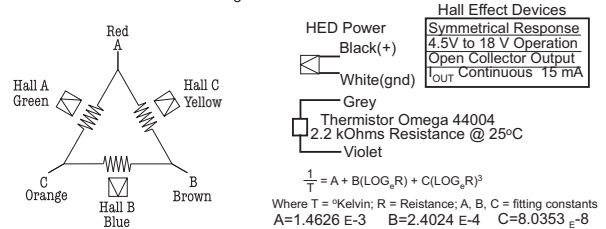

**WD7\***

Delta wound with Thermostat  
Digital Hall Effect Devices  
Dual Cables: THF06 and THF08

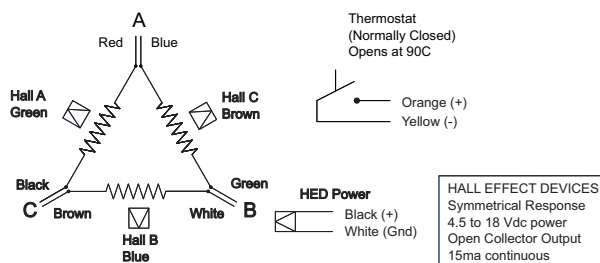

\*Preferred Configuration with Parker Drives

**NOTES**

1. Peak force and current based on 5% duty cycle and one second duration.
2. Continuous force and current based on coil winding temperature maintained at 100°C.
3. Force constant is peak of resistive force produced by 1.0 amp thru one motor lead and 0.5 amps thru other two leads. Also, Back EMF (V/in/sec) \* 7.665 = Force constant (lb/amp).
4. Motor resistance measured between any two motor leads with motor connected in Delta winding at 25°C. For temperature at 100°C, multiply resistance by 1.295 (75°C rise \* 0.393%/°C)
5. Back EMF measured between any two motor leads while moving at constant velocity. Value is amplitude or 0-Peak of sine wave produced.
6. Motor inductance measured using 1Kz with the motor in the magnetic field.
7. Electrical Time Constant is time it takes for motor value to reach 63% of its final current after a step change in voltage.

8. Thermal Time Constant is time it takes for motor temperature to reach 63% of its final value after a step change in power.
9. Thermal Resistance is the number of degrees (Celsius) of temperature rise in the winding per watt of power dissipated. Determined experimentally.
10. Motor Constant is a measure of efficiency. Calculated by dividing the force constant by the square root of the motor resistance at maximum operating temperature.
11. Electrical Cycle Length is distance coil must travel to complete 360° electrical cycle.
12. Use TIPS sizing software for the most accurate estimate of coil temperature for a particular motion profile.
13. Motors available with nickel plating or black epoxy coating on magnets. Track part number modified with -N or -B at end. Must be specified at time of order.



### I FORCE

- Ironless motor, patented, RE34674
- Cross-section: 4.50”H (114.3mm) x 2.00”W (50.8mm)
- Peak forces in two sizes to 883lbs (3928N), continuous forces to 197 lbs (878N)
- Precision ground 3-piece track (410 model)
- Two lengths of modular magnet tracks allow unlimited length of travel
- Single-piece magnet tracks to 72.24” length
- Prealigned embedded digital HEDs, also available in separate cable from motor leads
- Internal air cooling manifold or liquid cooling manifold
- Internal thermal cutout switch protects coil

### PERFORMANCE

MOTOR MODEL		410-2	410-3	410-4	410-6	410-8
Peak Force	N	1041.4	1523.6	2006.3	2967.2	3928.1
	lb	234.1	342.5	451.0	667.0	883.0
Continuous Force	N	233.1	340.8	448.9	663.7	878.6
	lb	52.4	76.6	100.9	149.2	197.5
Peak Power	W	2835	4050	5265	7695	10125
Continuous Power	W	142	203	263	385	506

### ELECTRICAL

MOTOR MODEL		410-2			410-3			410-4			410-6			410-8		
WIRING TYPE	UNITS	S	P	T	S	P	T	S	P	T	S	P	T	S	P	T
Peak Current	A <sub>pk sine</sub>	19.1	38.2	57.3	18.6	37.2	55.8	18.4	36.8	55.2	18.1	36.2	54.3	18.0	36.0	54.0
	(RMS)	13.5	27.0	40.5	13.2	23.6	39.5	13.0	26.0	39.0	12.8	25.6	38.4	12.7	25.5	38.2
Continuous Current	A <sub>pk sine</sub>	4.3	8.6	12.9	4.2	8.4	12.6	4.1	8.2	12.3	4.1	8.2	12.3	4.0	8.0	12.0
	(RMS)	3.0	6.1	9.1	3.0	5.9	8.9	2.9	5.8	8.7	2.9	5.8	8.7	2.8	5.7	8.5
Force Constant	N/A peak	54.5	27.3	18.2	81.8	40.9	27.3	109.0	54.5	36.3	163.7	81.8	54.6	218.4	109.2	72.8
	lb/A peak	12.3	6.1	4.1	18.4	9.2	6.1	24.5	12.3	8.2	36.8	18.4	12.3	49.1	24.6	16.4
Back EMF	V/m/s	63.0	31.5	21.0	94.5	47.2	31.5	126.0	63.0	42.0	189.0	94.5	63.0	252.0	126.0	84.0
V/in/s		1.60	0.80	0.53	2.40	1.20	0.80	3.20	1.60	1.07	4.80	2.40	1.60	6.40	3.20	2.13
Resistance 25°C, phase to phase	ohms	8.0	2.0	0.9	12.0	3.0	1.3	16.0	4.0	1.8	24.0	6.0	2.7	32.0	8.0	3.6
Inductance, phase to phase	mH	10.0	2.5	1.1	15.0	3.8	1.7	20.0	5.0	2.2	30.0	7.5	3.3	40.0	10.0	4.4
Electrical Time Constant	ms	1.3	1.3	1.3	1.3	1.3	1.3	1.3	1.3	1.3	1.3	1.3	1.3	1.3	1.3	1.3
Motor Constant	N/W	19.57	19.57	19.57	23.98	23.98	23.98	27.67	27.67	27.67	33.90	33.90	33.90	39.14	39.14	39.14
	lb/W	4.40	4.40	4.40	5.39	5.39	5.39	6.22	6.22	6.22	7.62	7.62	7.62	8.80	8.80	8.80
Max Terminal Voltage	VDC	330	330	330	330	330	330	330	330	330	330	330	330	330	330	330

NOTE: S-Series P-Parallel T-Triple

### THERMAL

MOTOR MODEL		410-2	410-3	410-4	410-6	410-8
Thermal Resistance Wind-Amb	degC / W	0.53	0.37	0.26	0.19	0.15
Thermal Time Constant	min	15.1	15.1	15.1	15.1	15.1
Maximum Winding Temperature	°C	100	100	100	100	100

### MECHANICAL

MOTOR MODEL		410-2	410-3	410-4	410-6	410-8
Coil Weight	kg	1.59	2.27	2.95	4.32	5.68
	lb	3.5	5.0	6.5	9.5	12.5
Coil Length	mm	199.1	284.5	369.8	540.5	711.2
	in	7.84	11.20	14.56	21.28	28.00
Attractive Force	N	0	0	0	0	0
	lbf	0	0	0	0	0
Electrical Cycle Length	mm	85.34	85.34	85.34	85.34	85.34
	in	3.36	3.36	3.36	3.36	3.36



**MODULAR  
41006M  
41010M**

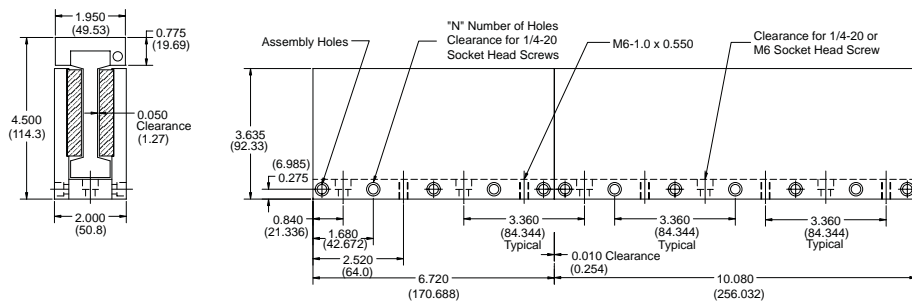

**Incremental Length:**  
3.36in/85.34mm

**Minimum Length:**  
6.72in/170.7mm

**Maximum Length:**  
70.56in/1792.22mm

**Weight/Foot:**  
20.0lbs/ft

**SINGLE PIECE  
410xxM1**

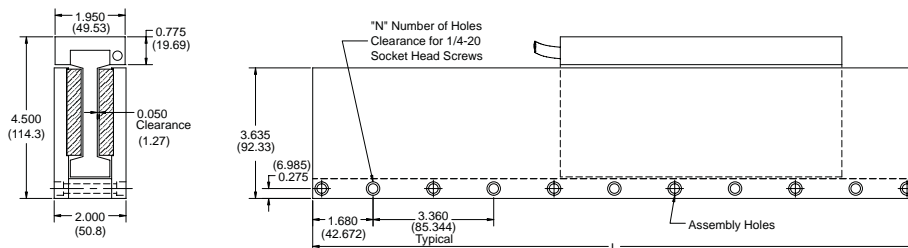

**Incremental Length:**  
3.36in/85.34mm

**Minimum Length:**  
6.72in/170.7mm

**Maximum Length:**  
70.56in/1792.22mm

**Weight/Foot:**  
20.0lbs/ft

**SINGLE PIECE  
410xxS**

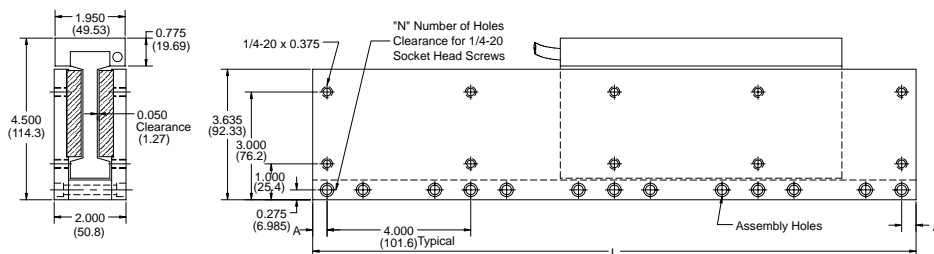

**Incremental Length:**  
1.68in/42.67mm

**Minimum Length:**  
16.80in/426.72mm

**Maximum Length:**  
72.24in/1834.9mm

**Weight/Foot:**  
20.0lbs/ft

**(A) ENGLISH TOP MOUNTING**

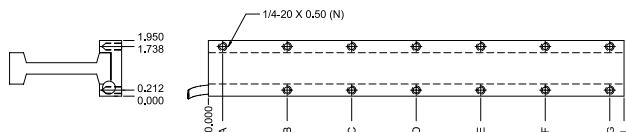

**(B) ENGLISH SIDE MOUNTING**

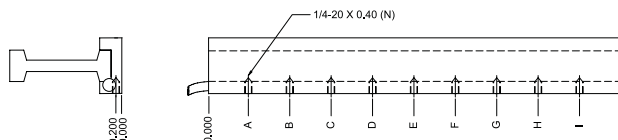

COIL SIZE (in)	L	N	A	B	C	D	E	F	G
410-2A	7.84	5	0.50	3.92	7.34	---	---	---	---
410-3A	11.20	8	0.50	1.60	5.60	9.60	10.70	---	---
410-4A	14.56	9	0.50	3.28	7.28	11.28	14.06	---	---
410-6A	21.28	13	0.50	2.64	6.64	10.64	14.64	18.64	20.78
410-8A	28.00	13	2.00	6.00	10.00	14.00	18.00	22.00	26.00

COIL SIZE (in)	L	N	A	B	C	D	E	F	G	H	I
410-2B	7.84	3	2.90	4.90	6.90	---	---	---	---	---	---
410-3B	11.20	3	4.10	7.10	10.10	---	---	---	---	---	---
410-4B	14.56	4	2.78	5.78	8.78	11.78	---	---	---	---	---
410-6B	21.28	6	3.14	6.14	9.14	12.14	15.14	18.14	---	---	---
410-8B	28.00	9	3.50	6.50	9.50	12.50	15.50	18.50	21.50	24.50	27.50

**(M) METRIC TOP MOUNTING**

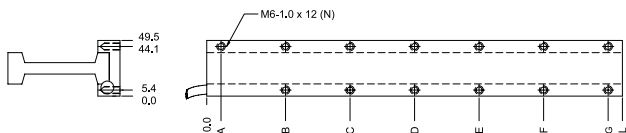

**(N) METRIC SIDE MOUNTING**

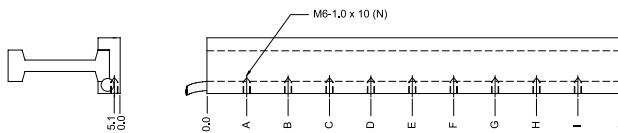

COIL SIZE (mm)	L	N	A	B	C	D	E	F	G
410-2M	199.1	5	12.7	99.6	186.4	---	---	---	---
410-3M	284.5	8	12.7	40.6	142.2	243.8	271.8	---	---
410-4M	369.8	9	12.7	83.3	184.9	286.5	357.1	---	---
410-6M	540.5	13	12.7	67.1	168.7	270.3	371.9	473.4	527.8
410-8M	711.2	13	50.8	152.4	254.0	355.6	457.2	558.8	660.4

COIL SIZE (mm)	L	N	A	B	C	D	E	F	G	H	I
410-2N	199.1	3	73.7	124.5	175.3	---	---	---	---	---	---
410-3N	284.5	3	104.1	180.3	256.5	---	---	---	---	---	---
410-4N	369.8	4	70.6	146.8	223.0	299.2	---	---	---	---	---
410-6N	540.5	6	79.7	156.0	232.2	308.4	384.6	460.8	---	---	---
410-8N	711.2	9	88.9	165.1	241.3	317.5	393.7	469.9	546.1	622.3	698.5



MODULAR TRACK			
LENGTH Inches	LENGTH In mm	QUANTITY 41006M	QUANTITY 41010M
6.72	170.69	1	0
10.08	256.03	0	1
13.44	341.38	0	0
16.80	426.72	1	1
20.16	512.06	0	2
23.52	597.41	2	1
26.88	682.75	1	2
30.24	768.10	0	3
33.60	853.44	2	2
36.96	938.78	1	3
40.32	1024.13	0	4
43.68	1109.47	2	3
47.04	1194.82	1	4
50.40	1280.16	0	5
53.76	1365.50	2	4
57.12	1450.85	1	5
60.48	1536.19	0	6
63.84	1621.54	2	5
67.20	1706.88	1	6
70.56	1792.22	0	7
73.92	1877.57	2	6
77.28	1962.91	1	7
80.64	2048.26	0	8
84.00	2133.60	2	7
87.36	2218.94	1	8
90.72	2304.29	0	9
94.08	2389.63	2	8
97.44	2474.98	1	9

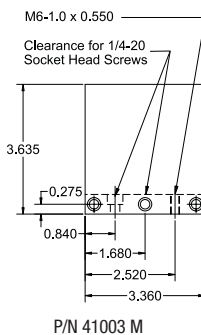

410 xx M1				
P/N	410xx M1	L (in)	L (mm)	N
41006 M1		6.72	170.69	2
41010 M1		10.08	256.03	3
41013 M1		13.44	341.38	4
41016 M1		16.80	426.72	5
41020 M1		20.16	512.06	6
41023 M1		23.52	597.41	7
41026 M1		26.88	682.75	8
41030 M1		30.24	768.10	9
41033 M1		33.60	853.44	10
41036 M1		36.96	938.78	11
41040 M1		40.32	1024.13	12
41043 M1		43.68	1109.47	13
41047 M1		47.04	1194.82	14
41050 M1		50.40	1280.16	15
41053 M1		53.76	1365.50	16
41057 M1		57.12	1450.85	17
41060 M1		60.48	1536.19	18
41063 M1		63.84	1621.54	19
41067 M1		67.20	1706.88	20
41070 M1		70.56	1792.22	21

SINGLE PIECE 410xxM				
P/N	410xx M	L (in)	L (mm)	N
41003 M		3.36	85.34	1
41006 M		6.72	170.69	2
41010 M		10.08	256.03	3
41013 M		13.44	341.38	4
41016 M		16.80	426.72	5
41020 M		20.16	512.06	6
41023 M		23.52	597.41	7
41026 M		26.88	682.75	8
41030 M		30.24	768.10	9
41033 M		33.60	853.44	10
41036 M		36.96	938.78	11
41040 M		40.32	1024.13	12
41043 M		43.68	1109.47	13
41047 M		47.04	1194.82	14
41050 M		50.40	1280.16	15
41053 M		53.76	1365.50	16
41057 M		57.12	1450.85	17
41060 M		60.48	1536.19	18
41063 M		63.84	1621.54	19
41067 M		67.20	1706.88	20
41070 M		70.56	1792.22	21



**WD1**

Delta wound with Thermistor  
Single Cable: THF05

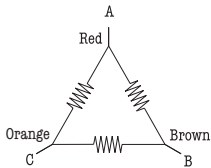

Orange  
Thermistor Omega 44004  
2.2 kOhms Resistance @ 25°C  
Yellow

$$\frac{1}{T} = A + B(\text{LOG}_e R) + C(\text{LOG}_e R)^3$$

Where T = °Kelvin; R = Resistance; A, B, C = fitting constants  
A=1.4626 E-3 B=2.4024 E-4 C=8.0353 E-8

**WD2**

Delta wound with Thermostat  
Single Cable: THF05

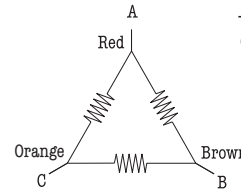

Thermostat(NC)  
Opens at 90°C  
Yellow(+)  
Orange(-)

**WD3**

Delta wound with Thermostat  
Digital Hall Effect Devices  
Dual Cable: THF05 and THF06

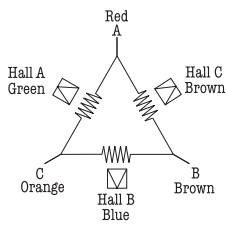

HED Power  
Black(+)  
White(gnd)

Thermostat(NC)  
Opens at 90°C  
Grey(+)  
Violet(-)

Hall Effect Devices  
Symmetrical Response  
4.5V to 18 V Operation  
Open Collector Output  
I<sub>OUT</sub> Continuous 15 mA

**WD4**

Delta wound with Thermistor  
Digital Hall Effect Devices  
Dual Cable: THF05 and THF06

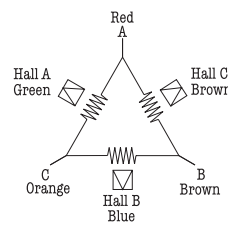

HED Power  
Black(+)  
White(gnd)

Grey  
Thermistor Omega 44004  
2.2 kOhms Resistance @ 25°C  
Violet

$$\frac{1}{T} = A + B(\text{LOG}_e R) + C(\text{LOG}_e R)^3$$

Where T = °Kelvin; R = Resistance; A, B, C = fitting constants  
A=1.4626 E-3 B=2.4024 E-4 C=8.0353 E-8

**NOTES**

1. Peak force and current based on 5% duty cycle and one second duration.
2. Continuous force and current based on coil winding temperature maintained at 100°C.
3. Force constant is peak of resistive force produced by 1.0 amp thru one motor lead and 0.5 amps thru other two leads. Also, Back EMF (V/in/sec) \* 7.665 = Force constant (lb/amp).
4. Motor resistance measured between any two motor leads with motor connected in Delta winding at 25°C. For temperature at 100°C, multiply resistance by 1.295 (75°C rise \* 0.393%/°C)
5. Back EMF measured between any two motor leads while moving at constant velocity. Value is amplitude or 0-Peak of sine wave produced.
6. Motor inductance measured using 1Kz with the motor in the magnetic field.
7. Electrical Time Constant is time it takes for motor value to reach 63% of its final current after a step change in voltage.
8. Thermal Time Constant is time it takes for motor temperature to reach 63% of its final value after a step change in power.
9. Thermal Resistance is the number of degrees (Celsius) of temperature rise in the winding per watt of power dissipated. Determined experimentally.
10. Motor Constant is a measure of efficiency. Calculated by dividing the force constant by the square root of the motor resistance at maximum operating temperature.
11. Electrical Cycle Length is distance coil must travel to complete 360° electrical cycle.
12. Use TIPS sizing software for the most accurate estimate of coil temperature for a particular motion profile.
13. Motors available with nickel plating or black epoxy coating on magnets. Track part number modified with -N or -B at end. Must be specified at time of order.

### Motor Coil

Order Example:

110 - 2 - B - NC - WD2 - P - 8

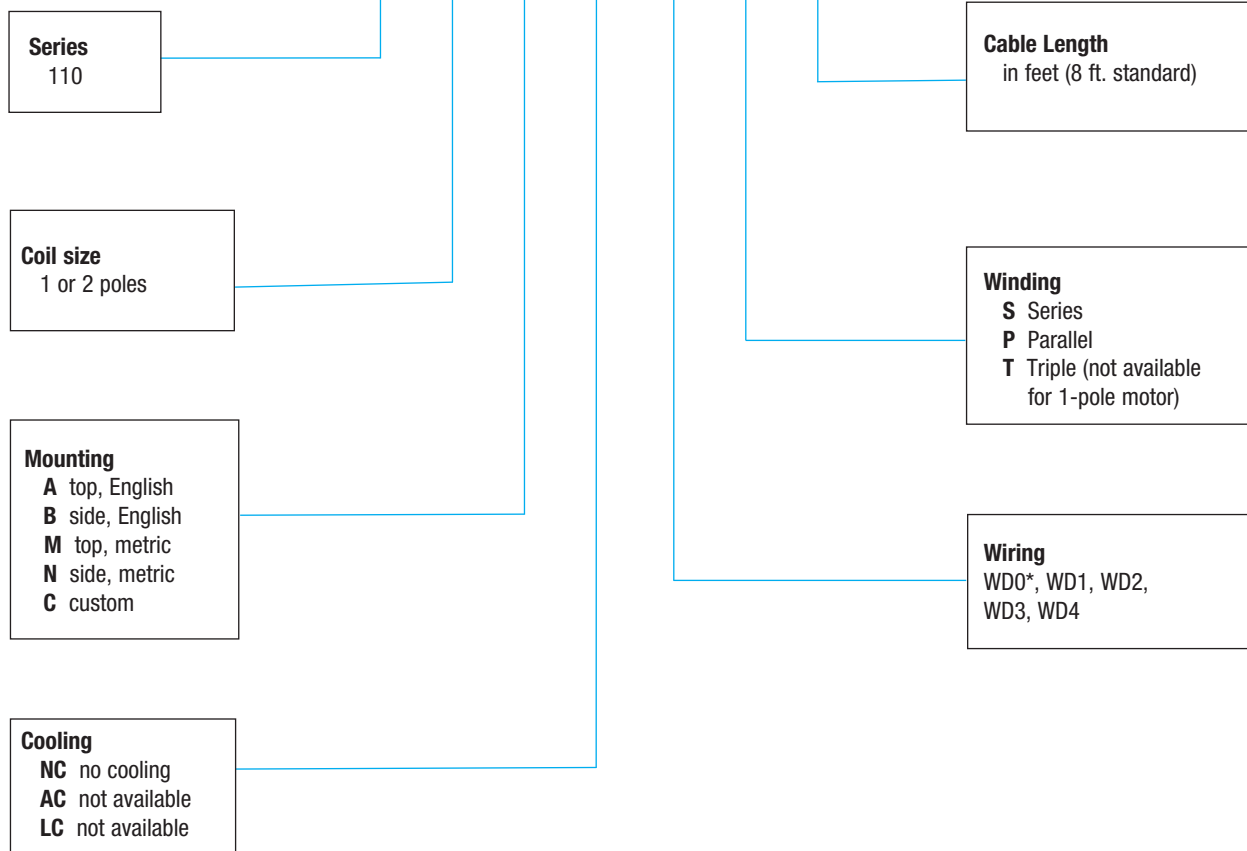

### Magnet Track:

11024M1 - N

<b>110xxM:</b>	11007M, 11009M	7.20", 9.60	modular sections
<b>11507M:</b>	11507M, 11509M	7.20", 9.60	modular sections
<b>110xxM1:</b>	11036M1, max	36.00" max	single piece, 2.4" incr.
<b>110xxM:</b>	11036M, max	36.00" max	single piece, 2.4" incr.
<b>115xxM:</b>	11524M, max	24.00" max	single piece, 2.4" incr.
<b>110xxS:</b>	11036M, max	36.00" max	single piece, 1.2" incr.

**Magnet coating**  
N nickel (standard)  
B black epoxy

## Motor Coil

Order Example:

210 - 2 M - NC - WD2 P - 8

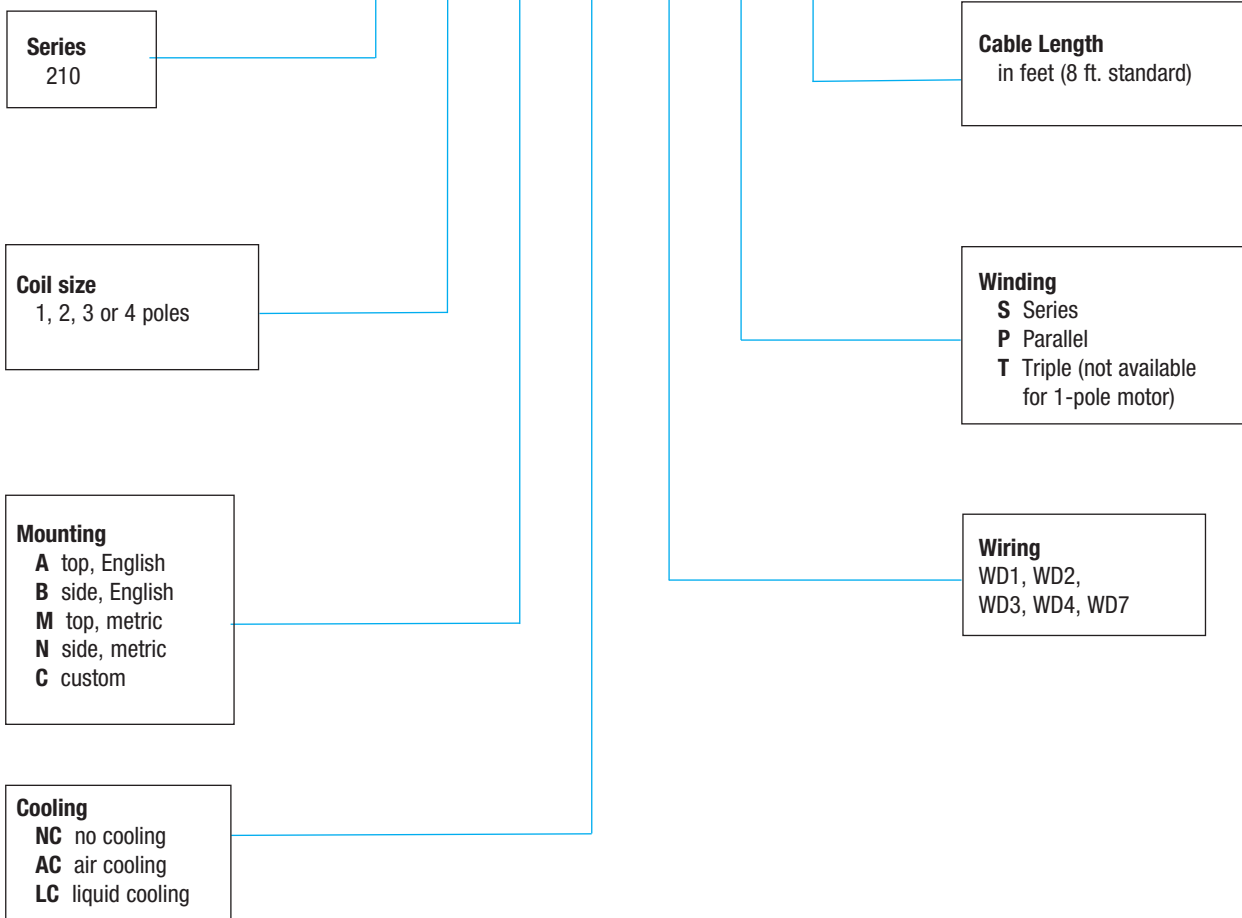

## Magnet Track:

21024M1 - N

<b>210xxM:</b>	21007M, 21009M	7.20", 9.60" modular sections
<b>21507M:</b>	21507M, 21509M	7.20", 9.60" modular sections
<b>210xxM1:</b>	21048M1 max	48.00" max single piece, 2.4" incr.
<b>210xxM:</b>	21048M max	48.00" max single piece, 2.4" incr.
<b>215xxM:</b>	21524M max	24.00" max single piece, 2.4" incr.
<b>210xxS:</b>	21048S max	48.00" max single piece, 1.2" incr.

<b>Magnet coating</b>
N nickel (standard)
B black epoxy

### Motor Coil

Order Example:

310 - 2 A - NC - WD2 P - 8

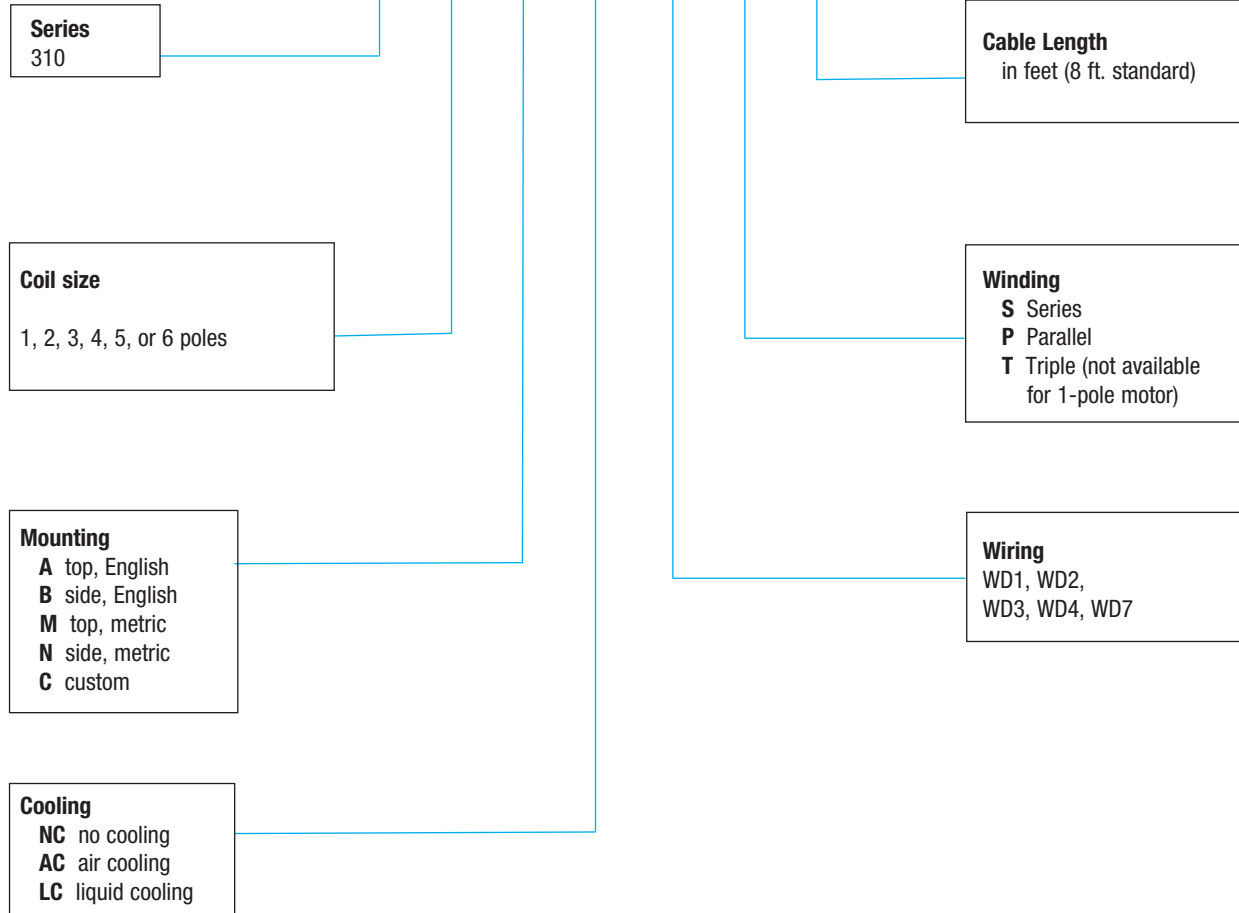

### Magnet Track:

31024M1 - N

<b>310xxM:</b>	31007M, 31009M	7.20", 9.60" modular sections
<b>31507M:</b>	31507M, 31509M	7.20", 9.60" modular sections
<b>310xxM1:</b>	31064M1 max	64.8" max single piece, 2.4" incr.
<b>310xxM:</b>	31064M max	64.80" max single piece, 2.4" incr.
<b>315xxM:</b>	31524M max	24.00" max single piece, 2.4" incr.
<b>310xxS:</b>	31066S max	64.8" max single piece, 1.2" incr.

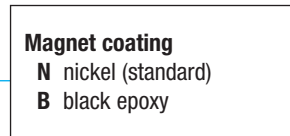

## Motor Coil

Order Example:

410 - 2 B - NC - WD2 P - 8

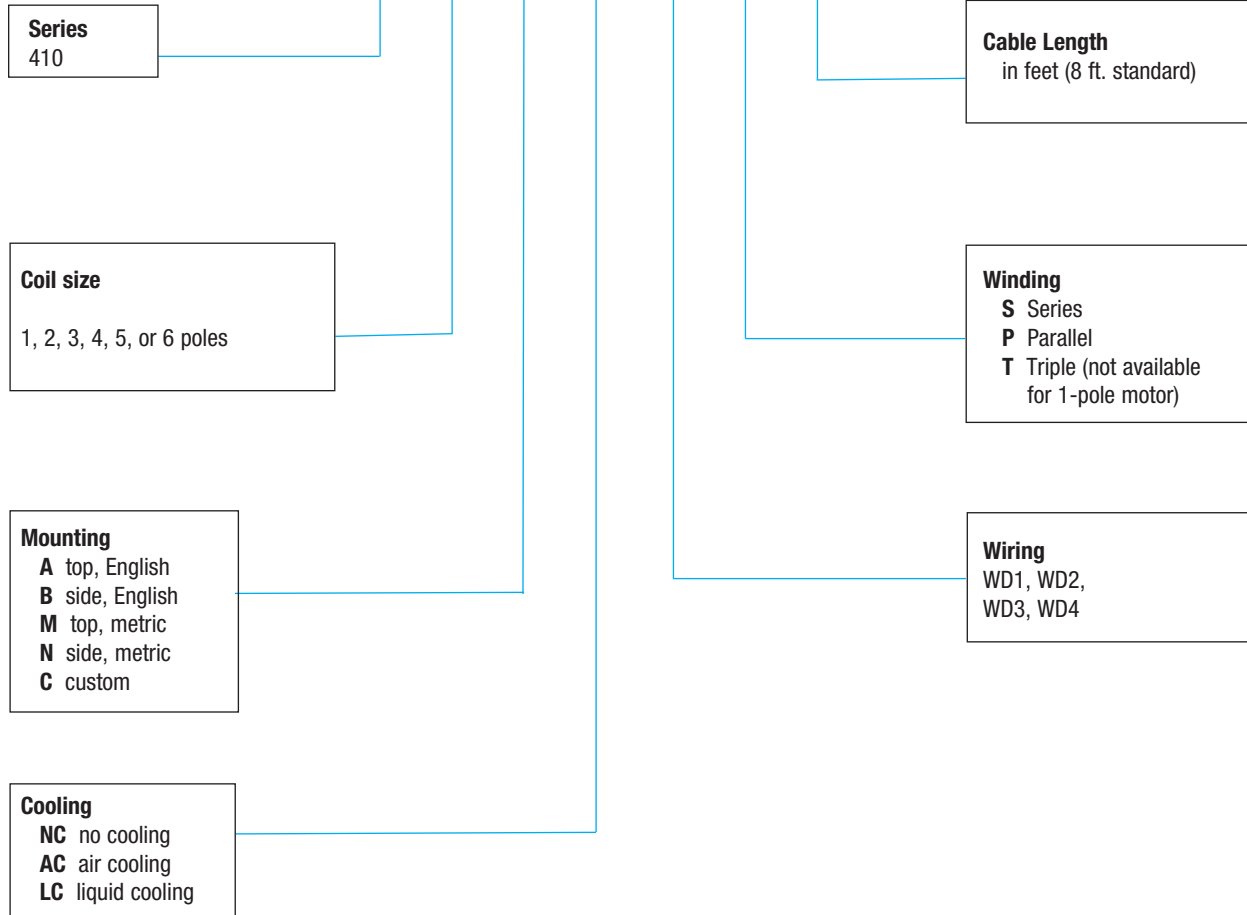

## Magnet Track:

41024M1 - N

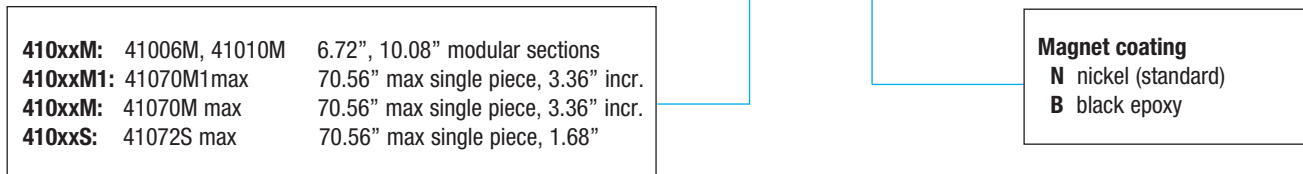



**I FORCE**

- Ironless motor, patented, RE34674
- Cross-section: 155mm x 50mm
- Peak forces to 3811N (856lbs), continuous forces to 852N (191lbs)
- Precision ground 3 piece track with magnet spacers
- Two lengths of modular magnet tracks allow unlimited length of travel
- Single piece magnet tracks to 480mm
- Connector module allows quick and easy installation
- HED sensors and overtravel limits available in connector module
- Internal thermal cutout switch protects coil

**PERFORMANCE**

MOTOR MODEL		ML50-2	ML50-3	ML50-4	ML50-6	ML50-8	ML50-9
Peak Force	N	847	1270	1694	2541	3387	3811
	lbs	190.4	285.6	380.8	571.1	761.5	856.7
Continuous Force	N	189	284	379	568	757	852
	lbs	42.6	63.9	85.1	127.7	170.3	191.6
Peak Power	W	1560	2340	3120	4680	6240	7020
Continuous Power	W	78	117	156	234	312	351

**ELECTRICAL**

MOTOR MODEL		ML50-2		ML50-3		ML50-4			ML50-6			ML50-8		ML50-9
WIRING TYPE	UNITS	S	P	S	T	S	P	D	S	P	T	P	D	T
Peak Current	A <sup>pk sine</sup>	19.9	39.8	19.9	59.7	19.9	39.8	79.7	19.9	39.8	59.7	39.8	79.7	59.7
	(RMS)	14.1	28.1	14.1	42.2	14.1	28.1	53.4	14.1	28.1	42.2	28.1	53.4	42.2
Continuous Current	A <sup>pk sine</sup>	4.5	8.9	4.5	13.4	4.5	8.9	17.8	4.5	8.9	13.4	8.9	17.8	13.4
	(RMS)	3.2	6.3	3.2	9.5	3.2	6.3	12.6	3.2	6.3	9.5	6.3	12.6	9.5
Force Constant	N/A	42.5	21.3	63.8	21.3	85.0	42.5	21.3	127.6	63.8	42.5	85.0	42.5	63.8
	lbs/A	9.6	4.8	14.3	4.8	19.1	9.6	4.8	28.7	14.3	9.6	19.1	9.6	14.3
Back EMF	V/m/s	49.1	24.5	73.6	24.5	98.2	49.1	24.5	147.3	73.6	49.1	98.2	49.1	73.6
	V/ips	1.2	0.6	1.9	0.6	2.5	1.2	0.6	3.7	1.9	1.2	2.5	1.2	1.9
Resistance	Ohms	4.1	1.0	6.1	0.7	8.1	2.0	0.5	12.2	3.0	1.4	4.1	1.0	2.0
Inductance	mH	3.3	0.8	5.0	0.6	6.6	1.7	0.4	9.9	2.5	1.1	3.3	0.8	1.7
Electrical Time Constant	ms	0.8	0.8	0.8	0.8	0.8	0.8	0.8	0.8	0.8	0.8	0.8	0.8	0.8
Motor Constant	N/ $\sqrt{W}$	21.4	21.4	26.3	26.3	30.3	30.3	30.3	37.1	37.1	37.1	42.9	42.9	45.5
	lbs/ $\sqrt{W}$	4.82	4.8	5.90	5.9	6.82	6.8	6.8	8.35	8.3	8.3	9.6	9.6	10.2
Max Terminal Voltage	VDC	330	330	330	330	330	330	330	330	330	330	330	330	330

**THERMAL**

MOTOR MODEL		ML50-2	ML50-3	ML50-4	ML50-6	ML50-8	ML50-9
Thermal Resistance Wind-Amb	degC / W	0.96	0.64	0.48	0.32	0.24	0.21
Thermal Time Constant	min	9.2	9.2	9.2	9.2	9.2	9.2
Maximum Winding Temperature	degC	100	100	100	100	100	100

**MECHANIC**

MOTOR MODEL		ML50-2	ML50-3	ML50-4	ML50-6	ML50-8	ML50-9
Coil Weight	kg	0.7	1.1	1.5	2.2	2.9	3.3
	lbs	1.6	2.4	3.2	4.8	6.4	7.2
Coil Length (does not include connector module)	mm	120	180	240	360	480	540
	in	4.724	7.087	9.449	14.173	18.898	21.260
Attractive Force	N	0	0	0	0	0	0
	lbs	0	0	0	0	0	0
Electrical Cycle Length	mm	60	60	60	60	60	60



## MODULAR TRACKS ML50-180M-N ML50-240M-N

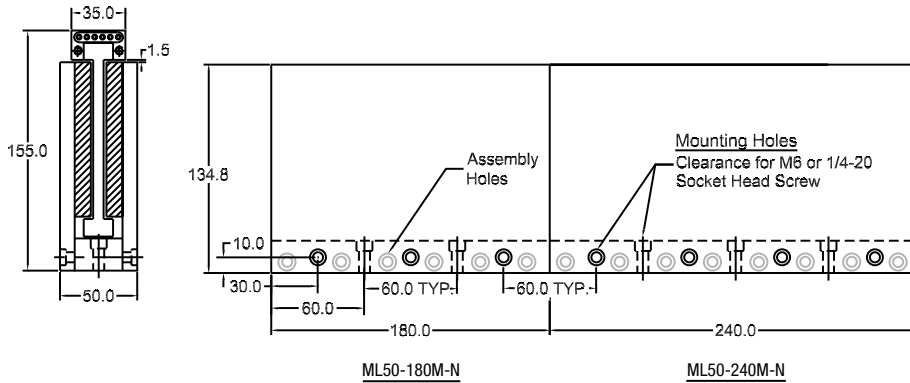

**Incremental Length:**  
60mm

**Maximum Single Piece Length:**  
480mm

**Minimum Length:**  
180mm

**Weight:**  
37.9 kg/m (25.4 lbs/ft)

## COIL ASSEMBLY ML50-xE-NC-Mx

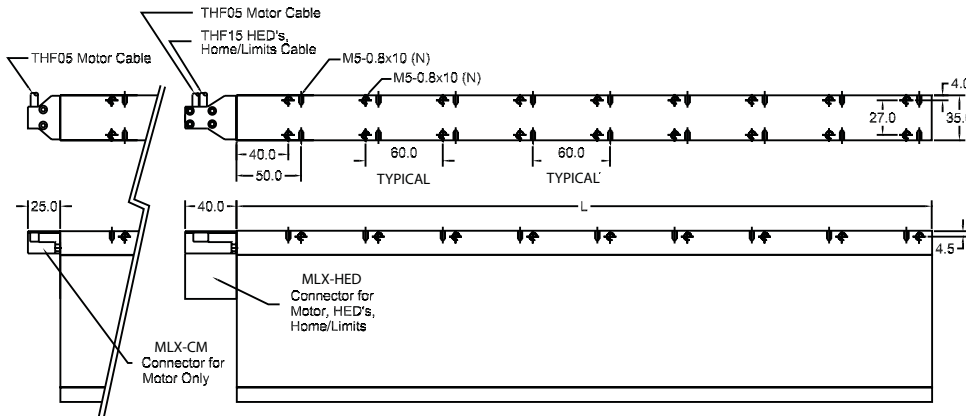

ML50 COIL ASSEMBLY		
ML50-XE	L	N
ML50-2E	120	4
ML50-3E	180	6
ML50-4E	240	8
ML50-6E	360	12
ML50-8E	480	16
ML50-9E	540	18

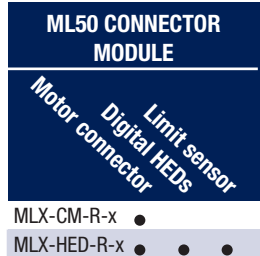

x = Cable length in meters

## NOTES

- Peak force and current based on 5% duty cycle and 1 sec duration.
- Continuous force and current based on coil winding temperature maintained at 100°C.
- Force constant is peak of resistive force produced by 1.0A thru one motor lead and 0.5A thru other two leads. Also, BackEMF (V/in/sec) \* 7.665 = Force constant (lb/A).
- Motor resistance measured between any two motor leads with motor connected in WYE winding at 25°C. For temperature at 100°C, multiply resistance by 1.295 (75°C rise \* 0.393%/°C)
- Back EMF measured between any two motor leads while moving at constant velocity. Value is amplitude or 0-Peak of sine wave produced.
- Motor inductance measured using 1kHz with the motor in the magnetic field.
- Electrical Time Constant is time it takes for motor current to reach 63% of it's final value after a step change in voltage.
- Thermal Time Constant is time it takes for motor temperature to reach 63% of it's final value after a step change in power.
- Thermal Resistance is the number of degrees (Celsius) of temperature rise in the winding per watt of power dissipated. Determined experimentally.
- Motor Constant is a measure of efficiency. Calculated by dividing the force constant by the square root of the motor resistance at maximum operating temperature.
- Electrical Cycle Length is distance coil must travel to complete 360° electrical cycle.
- Use TIPS sizing software for the most accurate estimate of coil temperature for a particular motion profile.

# RIPPED Ironcore Linear Motors



Parker Trilogi's RIPPED ironcore linear motors, with their patent-pending anti-cog technology, can produce the large forces needed for many industrial applications – without the roughness associated with traditional ironcore linear motors. With forces ranging from 13 lbf (57.8 N) continuous up to 1671 lbf (7433 N) peak, the RIPPED family is well suited for a broad range of extremely demanding applications.

The RIPPED motor connector modules allow quick and easy installation while reducing overall maintenance costs. Ultra-high-flex cables come standard. In addition, we offer modular magnet tracks for unrestricted travel length.

Virtually cog-free operation combined with powerful ironcore technology make the RIPPED family of motors a superior choice for high-force, ultra-smooth motion and affordability.

## Features and Benefits

- RIPPED Ironcore Linear Motor for high force applications
- Patent Pending ultra-smooth anti-cog technology
- Connector modules allow quick and easy installation
- Internal thermal cutout switch protects coil
- Digital HEDs, Home & +/-Limit Sensors incorporated into Connector Module
- Modular magnet tracks with flush mounted magnet separators
- Built in cable strain relief
- Two lengths of modular magnet tracks allow unlimited length of travel

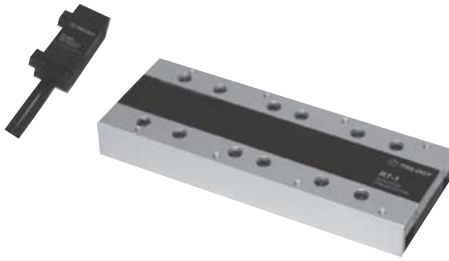

- RIPPED Ironcore motor, patent pending
- Cross-section: 55mm (2.165") x 37.5mm (1.476")
- Peak forces to 325N (73lbs), continuous forces to 97N (22lbs)
- Two lengths of modular magnet tracks allow unlimited length of travel
- Connector module allows quick and easy installation
- Internal thermal cutout switch protects coil

## PERFORMANCE

MOTOR MODEL		R5-1	R5-2
Peak Force*	N	190	325
	lbs	43	73
Continuous Force	N	56	97
	lbs	13	22
Peak Power	W	1920	2806
Continuous Power	W	96	140

## ELECTRICAL

MOTOR MODEL		R5-1	R5-2
<b>WIRING TYPE</b>	<b>Units</b>	<b>S-Series</b>	<b>S-Series</b>
Peak Current	A <sub>pk sine</sub>	11.2	19.2
	(RMS)	7.9	13.5
Continuous Current	A <sub>pk sine</sub>	2.5	4.3
	(RMS)	1.7	3.0
Force Constant *	N/A	22.5	22.5
	lbs/A	5.1	5.1
Back EMF	Vm/s	26.0	26.0
	V/ips	0.66	0.66
Resistance	Ohms	15.7	7.8
Inductance	mH	21.5	11.2
Electrical Time Constant	ms	1.4	1.4
Motor Constant	N/√W	5.8	8.2

## THERMAL

MOTOR MODEL		R5-1	R5-2
Thermal Resistance Wind-Amb	degC / W	0.78	0.53
Thermal Time Constant	min	5.9	5.9
Maximum Winding Temperature	° C	100	100

## MECHANICAL

MOTOR MODEL		R5-1	R5-2
Coil Weight	kg	0.6	1.0
	lbs	1.4	2.1
Coil Length (does not include connector module)	mm	130	190
	in	5.118	7.480
Attractive Force	N	667	979
	lbs	150	220
Electrical Cycle Length	mm	40	40
	in	1.575	1.575

\*Note: The force constant decreases at high current levels. The force constant at peak current is 3.80 lbs/A/pole.

### MODULAR TRACKS

R5-160-M-N  
R5-240-M-N

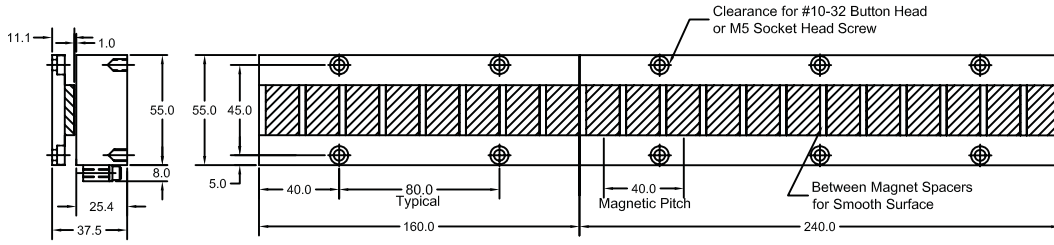

**Incremental Length:**  
80mm (3.1496)

**Minimum Length:**  
40mm (1.5748)

**Weight:**  
3.0kg/m (2.0lb/ft)

R5-160-M-N (Nickel Plated Magnets)  
R5-240-M-N (Nickel Plated Magnets)

R5-160-COVER (Optional)  
R5-240-COVER (Optional)

### COIL ASSEMBLY

R5-xxxxx

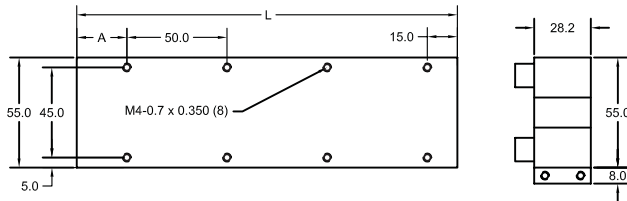

### R5 COIL ASSEMBLY

R5-xA-NC-MS	L	N	OAL	A
R5-1A-NC-MS	130	6	158.2	15
R5-2A-NC-MS	190	8	218.2	25

R5-1A-NC-MS Series Winding only  
R5-2A-NC-MS Series Winding only

### CONNECTOR MODULE

R5-xxx-xx-x

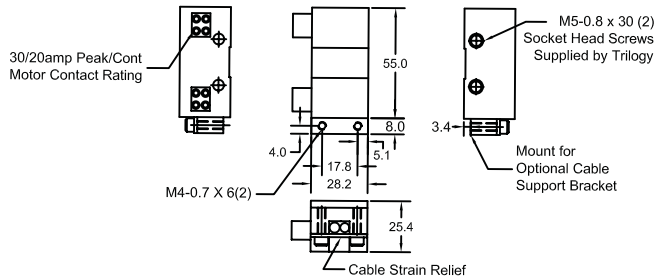

### R5 CONNECTOR MODULE

R5-xxx-Rx-x	Motor Connector	Digital HED's	Limit Sensors
R5-CM-Rx-x	✓		
R5-HED-Rx-x	✓	✓	✓

R5-xxx-RS-1 or -RP-1 or -RT-1: 1m cable standard.  
Module and Coil Assembly winding (S, P or T) must match.

## NOTES

- Peak force and current based on 5% duty cycle results in the maximum temperature rise.
- The force constant gradually decreases at high current levels. At the peak current the force constant is reduced by 24%. Refer to [www.trilogysystems.com](http://www.trilogysystems.com) for motor performance curves at different current levels. TIPS sizing software accommodates the changing force constant with current in its algorithms.
- Specifications are based on the maintaining the air gap between the coil and track shown in the drawings. Refer to [www.trilogysystems.com](http://www.trilogysystems.com) for motor performance curves at different air gaps.
- Continuous force and current based on coil winding temperature maintained at 100°C.
- Motor resistance measured between any two motor leads with motor connected in Wye winding at 25°C. For temperature at 100°C, multiply resistance by 1.295 (75°C rise \* 0.393%/°C).
- Thermal Resistance is the number of degrees (Celsius) of temperature rise in the winding per watt of power dissipated. Determined experimentally.
- Motor Constant is a measure of efficiency. Calculated by dividing the force constant by the square root of the motor resistance at maximum operating temperature.
- Use TIPS sizing software for the most accurate estimate of coil temperature for a particular motion profile.

## SAFETY

- USE EXTREME CAUTION IN HANDLING TRACKS. Ironcore Linear Motors contain exposed magnets and have an open magnetic field. Any ferrous metal, steel or iron, will be attracted to the magnet track. The amount of attractive force increases significantly as the distance from the track and coil or other metal object.
- USE EXTREME CAUTION WHEN INSTALLING THE COIL. The data sheet lists the attractive force between the coil and track. Refer to the "Motor Installation Guide" for proper installation instructions.
- ANY PERSON WITH MEDICAL ELECTRONIC IMPLANTS SHOULD USE EXTREME CAUTION WHEN NEAR AN OPEN MAGNETIC FIELD. The magnetic field could interfere with the medical device's operation.
- ANY PERSON WORKING OR HANDLING THE TRACKS SHOULD REMOVE PERSONAL EFFECTS. Items such as jewelry, watches, keys and credit cards may be damaged or adversely affected by the magnetic field.



- RIPPED Ironcore motor, patent pending
- Cross-section: 70mm (2.756") x 37.5mm (1.476")
- Peak forces in three sizes to 1761N (396lbs), continuous forces to 462N (104lbs)
- Two lengths of modular magnet tracks allow unlimited length of travel
- Connector modules allow quick and easy installation
- Internal thermal cutout switch protects coil

## PERFORMANCE

MOTOR MODEL		R7-1	R7-2	R7-3
Peak Force	N	587	1174	1761
	lb	132	264	396
Continuous Force	N	154	308	462
	lb	35	69	104
Peak Power	W	3600	7200	10800
Continuous Power	W	180	360	540

## ELECTRICAL

MOTOR MODEL		R7-1	R7-2		R7-3	
WIRING TYPE	UNITS	S-Series	S-Series	P-Parallel	S-Series	T-Triple
Peak Current	A pk sine	29.7	29.7	59.4	29.7	89.1
	(RMS)	21.0	21.0	42.0	21.0	63.0
Continuous Current	A pk sine	6.6	6.6	13.2	6.6	19.8
	(RMS)	4.6	4.6	9.3	4.6	14.0
Force Constant	N/A peak	23.2	46.4	23.2	69.6	23.2
	lb/A peak	5.2	10.4	5.2	15.6	5.2
Back EMF	V/m/s	26.8	53.5	26.8	80.3	26.8
	V/in/s	0.68	1.36	0.68	2.04	0.68
Resistance 25°C, phase to phase	ohms	4.2	8.4	2.1	12.6	1.4
Inductance, phase to phase	mH	6.1	12.2	3.1	18.3	2.0
Electrical Time Constant	ms	1.5	1.5	1.5	1.5	1.5
Motor Constant	N/√W	11.5	16.2	16.2	19.9	19.9
	lb/√W	2.58	3.65	3.65	4.47	4.47
Max Terminal Voltage	VDC	330	330		330	

## THERMAL

MOTOR MODEL		R7-1	R7-2	R7-3
Thermal Resistance Wind-Amb	degC / W	0.42	0.21	0.14
Thermal Time Constant	min	12.7	12.7	12.7
Maximum Winding Temperature	°C	100	100	100

## MECHANICAL

MOTOR MODEL		R7-1	R7-2	R7-3
Coil Weight	kg	1.5	3.0	4.5
	lb	3.3	6.7	10.0
Coil Length (includes connector module)	mm	218.2	378.2	538.2
	in	8.590	14.890	21.189
Attractive Force	N	1557	3114	4671
	lbf	350	700	1050
Electrical Cycle Length	mm	40	40	40
	in	1.575	1.575	1.575

### MODULAR TRACKS R7-160-M-x R7-240-M-x

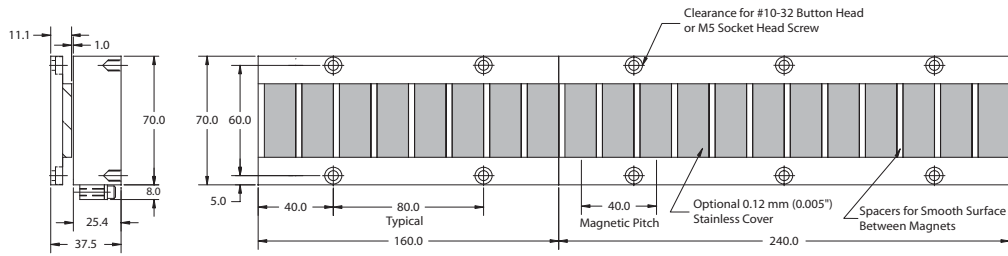

**Incremental Length:**  
80.0mm (3.1496")

**Minimum Length:**  
160.0mm (6.2992")

**Weight:**  
4.57Kg/m (3.08lbs/ft)

R7-160-M-N (Nickel Plated Magnets)  
R7-240-M-N (Nickel Plated Magnets)

R7-160-COVER (Optional)  
R7-240-COVER (Optional)

### COIL ASSEMBLY R7-xA-NC-Mx

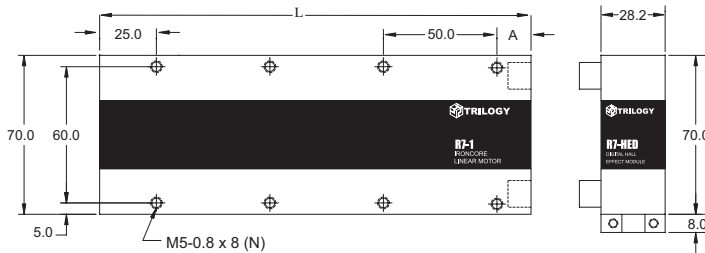

### R7 COIL ASSEMBLY

R7-xA-NC-Mx	L	N	OAL	A
R7-1A-NC-Mx	190.0	8	218.2	15
R7-2A-NC-Mx	350.0	14	378.2	25
R7-3A-NC-Mx	510.0	20	538.2	35

R7-1A-NC-MS Series Winding  
R7-2A-NC-MS or -MP Series or Parallel Winding  
R7-3A-NC-MS or -MT Series or Triple Winding

### CONNECTOR MODULE R7-xxx-Rx-x

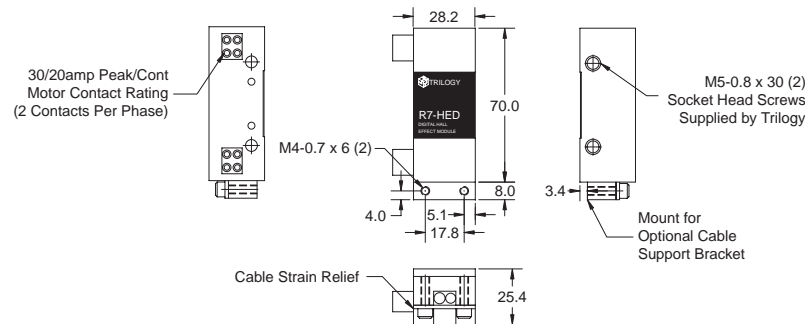

### R7 CONNECTOR MODULE

R7-xxx-Rx-x	Motor Connector	Digital HED's	Limit Sensors
R7-CM-Rx-x	✓		
R7-HED-Rx-x	✓	✓	✓

R7-xxx-RS-1 or -RP-1 or -RT-1: 1m cable standard.  
Module and Coil Assembly winding (S, P or T) must match.

### NOTES

- Peak force and current based on 5% duty cycle results in the maximum temperature rise.
- The force constant gradually decreases at high current levels. At the peak current the force constant is reduced by 24%. Refer to [www.trilogysystems.com](http://www.trilogysystems.com) for motor performance curves at different current levels. TIPS sizing software accommodates the changing force constant with current in its algorithms.
- Specifications are based on the maintaining the air gap between the coil and track shown in the drawings. Refer to [www.trilogysystems.com](http://www.trilogysystems.com) for motor performance curves at different air gaps.
- Continuous force and current based on coil winding temperature maintained at 100°C.
- Motor resistance measured between any two motor leads with motor connected in Wye winding at 25°C. For temperature at 100°C, multiply resistance by 1.295 (75°C rise \* 0.393%/°C).
- Thermal Resistance is the number of degrees (Celsius) of temperature rise in the winding per watt of power dissipated. Determined experimentally.
- Motor Constant is a measure of efficiency. Calculated by dividing the force constant by the square root of the motor resistance at maximum operating temperature.
- Use TIPS sizing software for the most accurate estimate of coil temperature for a particular motion profile.

### SAFETY

- USE EXTREME CAUTION IN HANDLING TRACKS. Ironcore Linear Motors contain exposed magnets and have an open magnetic field. Any ferrous metal, steel or iron, will be attracted to the magnet track. The amount of attractive force increases significantly as the distance from the magnet decreases. Severe injury may occur to fingers or hands if caught between the track and coil or other metal object.
- USE EXTREME CAUTION WHEN INSTALLING THE COIL. The data sheet lists the attractive force between the coil and track. Refer to the "Motor Installation Guide" for proper installation instructions.
- ANY PERSON WITH MEDICAL ELECTRONIC IMPLANTS SHOULD USE EXTREME CAUTION WHEN NEAR AN OPEN MAGNETIC FIELD. The magnetic field could interfere with the medical device's operation.
- ANY PERSON WORKING OR HANDLING THE TRACKS SHOULD REMOVE PERSONAL EFFECTS. Items such as jewelry, watches, keys and credit cards may be damaged or adversely affected by the magnetic field.

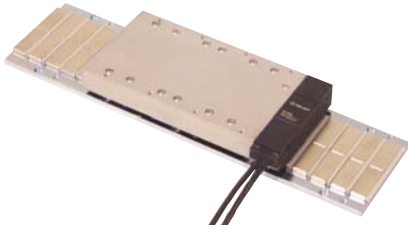
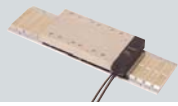

- RIPPED Ironcore motor, patent pending
- Cross-section: 110mm (4.331) x 37.5mm (1.476)
- Peak forces to 3184N (716lbs), continuous forces to 918N (206lbs)
- Two lengths of modular magnet tracks allow unlimited length of travel
- Connector module allows quick and easy installation
- Internal thermal cutout switch protects coil

## PERFORMANCE

MOTOR MODEL		R9-1	R9-2	R9-3
Peak Force	N	1061	2123	3184
	lb	239	477	716
Continuous Force	N	306	612	918
	lb	69	138	206
Peak Power	W	4800	9600	14400
Continuous Power	W	240	480	720

## ELECTRICAL

MOTOR MODEL		R9-1	R9-2	R9-3		
WIRING TYPE	UNITS	S-Series	S-Series	P-Parallel	S-Series	T-Triple
Peak Current	A <sub>pk sine</sub>	29.5	29.5	59.1	29.5	88.6
	(RMS)	20.8	20.8	41.8	20.8	62.6
Continuous Current	A <sub>pk sine</sub>	6.6	6.6	13.2	6.6	19.8
	(RMS)	4.6	4.6	9.3	4.6	14.0
Force Constant	N/A	46.5	92.7	46.4	139.1	46.4
	lbs/A	10.4	20.8	10.4	31.3	10.4
Back EMF	V/m/s	53.5	107.1	53.5	160.6	53.5
	V/ips	1.36	2.72	1.4	4.08	1.4
Resistance	Ohms	5.7	11.3	2.8	17.0	1.9
Inductance	mH	11.5	22.9	5.7	34.4	3.8
Electrical Time Constant	ms	2.0	2.0	2.0	2.0	2.0
Motor Constant	N/√W	19.8	27.9	27.9	34.2	34.2
	lbs/√W	4.44	6.28	6.3	7.69	7.7
Max Terminal Voltage	VDC	330	330		330	

## THERMAL

MOTOR MODEL		R9-1	R9-2	R9-3
Thermal Resistance Wind-Amb	degC / W	0.31	0.16	0.10
Thermal Time Constant	min	32.3	32.3	32.3
Maximum Winding Temperature	deg C	100	100	100

## MECHANICAL

MOTOR MODEL		R9-1	R9-2	R9-3
Coil Weight	kg	3.0	6.0	9.0
	lbs	6.6	13.2	19.8
Coil Length (does not include connector module)	mm	190	350	510
	in	7.480	13.780	20.080
Attractive Force	N	3114	6227	9341
	lbs	700	1400	2100
Electrical Cycle Length	mm	40	40	40

### MODULAR TRACKS

R9-160M-N  
R9-240M-N

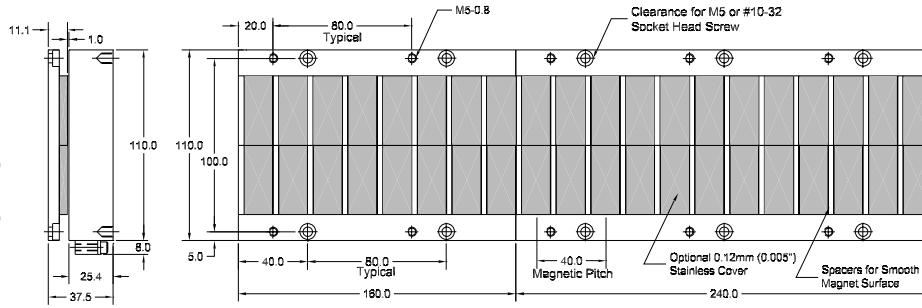

**Incremental Length:**  
80mm (3.150)

**Minimum Length:**  
40.0mm (1.575)

**Weight:**  
7.8 kg/m (5.2 lbs/ft)

**R9-160M-N** (Nickel Plated Magnets)  
**R9-240M-N** (Nickel Plated Magnets)

### COIL ASSEMBLY

R9-XA-NC-Mx

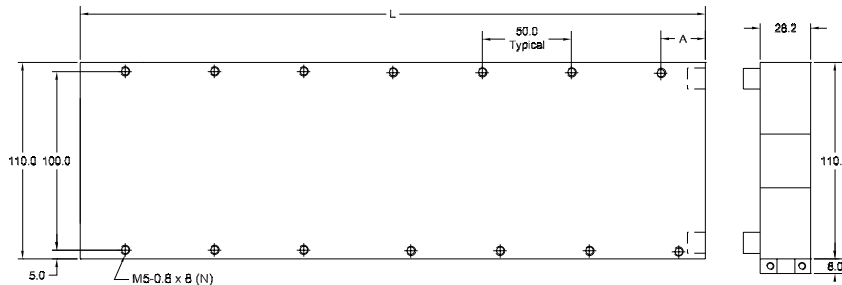

### R9 COIL ASSEMBLY

R9-XA-NC-Mx	L	A	N	OAL
R9-1A-NC-MS	190.0	15.0	8	218.2
R9-2A-NC-Mx	350.0	25.0	14	378.2
R9-3A-NC-Mx	510.0	35.0	20	538.2

R9-1A-NC-MS Series Winding Only  
R9-2A-NC-MS or MP Series or Parallel Winding  
R9-3A-NC-MS or MT Series or Triple Parallel Winding

### CONNECTOR MODULE

R9-xxx-Rx-x

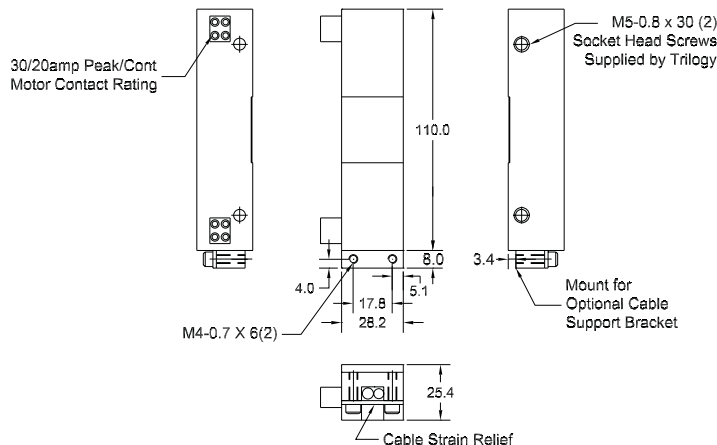

### R9 CONNECTOR MODULE

Motor Connector  
Digital HEDs  
Limit Sensor

R9-CM-Rx-x	●
R9-HED-Rx-x	● ● ●

R9-xxx-RS-1 or -RP-1 or -RT-1: 1m cable standard  
Module and Coil Assembly winding (S, P or T) must match

## NOTES

- Peak force for the R9 is not limited by the temperature rise. Using the peak current at a 6.4% duty cycle results in the maximum temperature rise.
- The force constant gradually decreases at high current levels. At the peak current the force constant is reduced by 27%. [www.trilogysystems.com](http://www.trilogysystems.com) for motor performance curves at different current levels. TIPS sizing software accommodates the changing force constant with current in its algorithms.
- Specifications are based on the maintaining the air gap between the coil and track shown in the drawings. Refer to [www.trilogysystems.com](http://www.trilogysystems.com) for motor performance curves at different air gaps.
- Continuous force and current based on coil winding temperature maintained at 100°C.
- Motor resistance measured between any two motor leads with motor connected in Wye winding at 25°C. For temperature at 100°C, multiply resistance by 1.295 (75°C rise \* 0.393% / °C).
- Thermal Resistance is the number of degrees (Celsius) of temperature rise in the winding per watt of power dissipated. Determined experimentally.
- Motor Constant is a measure of efficiency. Calculated by dividing the force constant by the square root of the motor resistance at maximum operating temperature.
- Use TIPS sizing software for the most accurate estimate of coil temperature for a particular motion profile.

## SAFETY

- USE EXTREME CAUTION IN HANDLING TRACKS. Ironcore Linear Motors contain exposed magnets and have an open magnetic field. Any ferrous metal, steel or iron, will be attracted to the magnet track. The amount of attractive force increases significantly as the distance from the magnet decreases. Severe injury may occur to fingers or hands if caught between the track and coil or other metal object.
- USE EXTREME CAUTION WHEN INSTALLING THE COIL. The data sheet lists the attractive force between the coil and track. Refer to the "Motor Installation Guide" for proper installation instructions.
- ANY PERSON WITH MEDICAL ELECTRONIC IMPLANTS SHOULD USE EXTREME CAUTION WHEN NEAR AN OPEN MAGNETIC FIELD. The magnetic field could interfere with the medical device's operation.
- ANY PERSON WORKING OR HANDLING THE TRACKS SHOULD REMOVE PERSONAL EFFECTS. Items such as jewelry, watches, keys and credit cards may be damaged or adversely affected by the magnetic field.



- RIPPED Ironcore motor, patent pending
- Cross-section: 100mm (3.94") x 58mm (2.28")
- Peak forces in three sizes to 4097N (921lbs), continuous forces to 1121N (252lbs)
- Two lengths of modular magnet tracks allow unlimited length of travel
- Connector modules allow quick and easy installation
- Internal thermal cutout switch protects coil

## PERFORMANCE

MOTOR MODEL		R10-1	R10-2	R10-3
Peak Force	N	1366	2731	4097
	lb	307	614	921
Continuous Force	N	374	747	1121
	lb	84	168	252
Peak Power	W	6098	12196	18294
Continuous Power	W	305	610	915

## ELECTRICAL

MOTOR MODEL		R10-1	R10-2			R10-3
WIRING TYPE	UNITS	S-Series	S-Series	P-Parallel	S-Series	T-Triple
Peak Current	A <sup>pk sine</sup>	35.1	35.1	70.2	35.1	105.3
	(RMS)	24.8	24.8	49.6	24.8	74.4
Continuous Current	A <sup>pk sine</sup>	7.8	7.8	15.6	7.8	23.4
	(RMS)	5.5	5.5	11.0	5.5	16.5
Force Constant	N/A peak	47.7	95.5	47.7	143.2	47.7
	lb/A peak	10.7	21.5	10.7	32.2	10.7
Back EMF	V/m/s	55.1	110.2	55.1	165.4	55.1
	V/in/s	1.40	2.80	1.40	4.20	1.40
Resistance 25°C, phase to phase	ohms	5.1	10.2	2.6	15.3	1.7
Inductance, phase to phase	mH	15.4	30.8	7.7	46.2	5.1
Electrical Time Constant	ms	3	3	3	3	3
Motor Constant	N/√W	21.4	30.3	30.3	37.1	37.1
	lb/√W	4.82	6.82	6.82	8.35	8.35
Max Terminal Voltage	VDC	330	330	330	330	330

## THERMAL

MOTOR MODEL		R10-1	R10-2	R10-3
Thermal Resistance Wind-Amb	degC / W	0.24	0.12	0.08
Thermal Time Constant	min	14.6	14.6	14.6
Maximum Winding Temperature	°C	100	100	100

## MECHANICAL

MOTOR MODEL		R10-1	R10-2	R10-3
Coil Weight	kg	4.5	9.1	13.6
	lb	10.0	20.0	30.0
Coil Length (includes connector module)	mm	305.5	545.5	785.5
	in	12.027	21.476	30.925
Attractive Force	N	3559	7117	10675
	lbf	800	1600	2400
Electrical Cycle Length	mm	60	60	60
	in	2.362	2.362	2.362

### MODULAR TRACKS R10-180-M-x R10-240-M-x

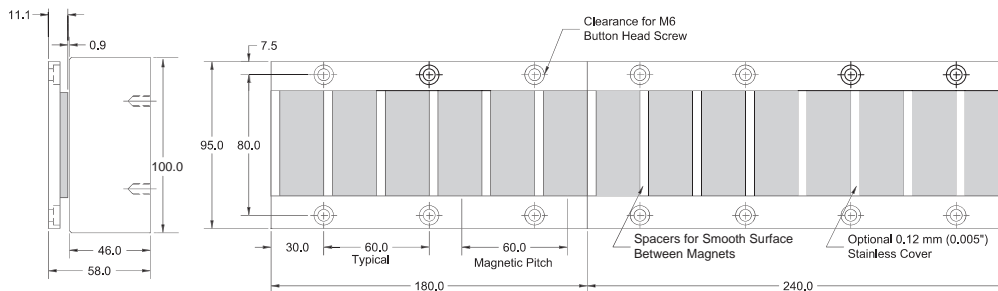

**Incremental Length:**  
60.0mm (2.3622")

**Minimum Length:**  
180.0mm (7.0866")

**Weight:**  
6.51Kg/m (4.38lbs/ft)

R10-180-M-N (Nickel Plated Magnets)  
R10-240-M-N (Nickel Plated Magnets)

R10-180-COVER (Optional)  
R10-240-COVER (Optional)

### COIL ASSEMBLY R10-xA-NC-Mx

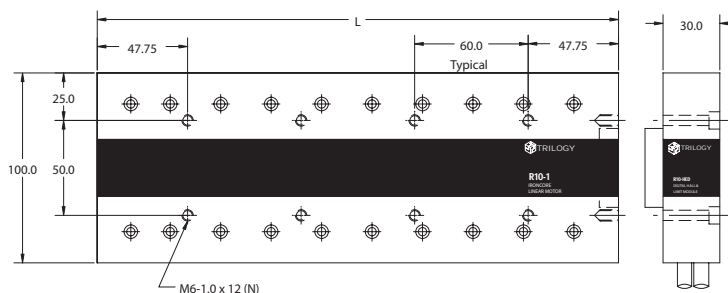

### R10 COIL ASSEMBLY

R10-xA-NC-Mx	L	N	OAL
R10-1A-NC-Mx	275.5	8	305.5
R10-2A-NC-Mx	505.5	16	535.5
R10-3A-NC-Mx	755.5	24	785.5

R10-1A-NC-MS Series Winding  
R10-2A-NC-MS or -MP Series or Parallel Winding  
R10-3A-NC-MS or -MT Series or Triple Winding

### CONNECTOR MODULE R10-xxx-Rx-x

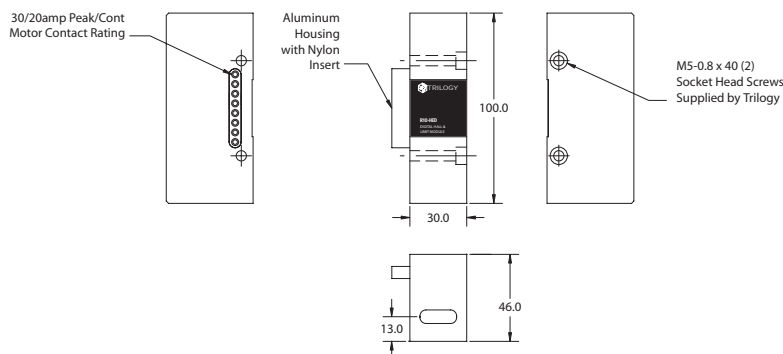

### R10 CONNECTOR MODULE

R10-xxx-Rx-x	Motor Connector	Digital HED's	Limit Sensors
R10-CM-Rx-x	✓		
R10-HED-Rx-x	✓	✓	✓

R10-xxx-RS-1 or -RP-1 or -RT-1: 1m cable standard.  
Module and Coil Assembly winding (S, P or T) must match.

### NOTES

- Peak force for the R10 is not limited by the temperature rise. Using the peak current at a 6.4% duty cycle results in the maximum temperature rise.
- The force constant gradually decreases at high current levels. At the peak current the force constant is reduced by 27%. Refer to [www.trilogysystems.com](http://www.trilogysystems.com) for motor performance curves at different current levels. TIPS sizing software accommodates the changing force constant with current in its algorithms.
- Specifications are based on the maintaining the air gap between the coil and track shown in the drawings. Refer to [www.trilogysystems.com](http://www.trilogysystems.com) for motor performance curves at different air gaps.
- Continuous force and current based on coil winding temperature maintained at 100°C.
- Motor resistance measured between any two motor leads with motor connected in Wye winding at 25°C. For temperature at 100°C, multiply resistance by 1.295 (75°C rise \* 0.393%/°C).
- Thermal Resistance is the number of degrees (Celsius) of temperature rise in the winding per watt of power dissipated. Determined experimentally.
- Motor Constant is a measure of efficiency. Calculated by dividing the force constant by the square root of the motor resistance at maximum operating temperature.
- Use TIPS sizing software for the most accurate estimate of coil temperature for a particular motion profile.

### SAFETY

- USE EXTREME CAUTION IN HANDLING TRACKS. Ironcore Linear Motors contain exposed magnets and have an open magnetic field. Any ferrous metal, steel or iron, will be attracted to the magnet track. The amount of attractive force increases significantly as the distance from the magnet decreases. Severe injury may occur to fingers or hands if caught between the track and coil or other metal object.
- USE EXTREME CAUTION WHEN INSTALLING THE COIL. The data sheet lists the attractive force between the coil and track. Refer to the "Motor Installation Guide" for proper installation instructions.
- ANY PERSON WITH MEDICAL ELECTRONIC IMPLANTS SHOULD USE EXTREME CAUTION WHEN NEAR AN OPEN MAGNETIC FIELD. The magnetic field could interfere with the medical device's operation.
- ANY PERSON WORKING OR HANDLING THE TRACKS SHOULD REMOVE PERSONAL EFFECTS. Items such as jewelry, watches, keys and credit cards may be damaged or adversely affected by the magnetic field.



- RIPPED Ironcore motor, patent pending
- Cross-section: 160mm (6.30") x 58mm (2.28")
- Peak forces in three sizes to 7435N (1671lbs), continuous forces to 2230N (501lbs)
- Two lengths of modular magnet tracks allow unlimited length of travel
- Connector modules allow quick and easy installation
- Internal thermal cutout switch protects coil

## PERFORMANCE

MOTOR MODEL		R16-1	R16-2	R16-3
Peak Force	N	2478	4955	7433
	lb	557	1114	1671
Continuous Force	N	743	1487	2230
	lb	167	334	501
Peak Power	W	7065	14130	21195
Continuous Power	W	353	707	1060

## ELECTRICAL

MOTOR MODEL		R16-1	R16-2	R16-3		
WIRING TYPE	UNITS	S-Series	S-Series	P-Parallel	S-Series	T-Triple
Peak Current	A <sup>pk sine</sup>	34.8	34.8	69.8	34.8	104.5
	(RMS)	24.6	24.6	49.3	24.6	73.9
Continuous Current	A <sup>pk sine</sup>	7.8	7.8	15.6	7.8	23.4
	(RMS)	5.5	5.5	11.0	5.5	16.5
Force Constant	N/A peak	95.5	190.9	95.5	286.4	95.5
	lb/A peak	21.5	42.9	21.5	64.4	21.5
Back EMF	V/m/s	110.2	220.5	110.2	330.7	110.2
	V/in/s	2.80	5.60	2.80	8.40	2.80
Resistance 25°C, phase to phase	ohms	6.0	12.0	3.0	18.0	2.0
Inductance, phase to phase	mH	29.0	58.0	14.5	87.0	9.7
Electrical Time Constant	ms	4.8	4.8	4.8	4.8	4.8
Motor Constant	N/ $\sqrt{W}$	39.6	55.9	55.9	68.5	68.5
	lb/ $\sqrt{W}$	8.89	12.57	12.57	15.40	15.40
Max Terminal Voltage	VDC	330	330		330	

## THERMAL

MOTOR MODEL		R16-1	R16-2	R16-3
Thermal Resistance Wind-Amb	degC/ W	0.21	0.11	0.07
Thermal Time Constant	min	37.1	37.1	37.1
Maximum Winding Temperature	°C	100	100	100

## MECHANICAL

MOTOR MODEL		R16-1	R16-2	R16-3
Coil Weight	kg	9.10	18.20	27.30
	lb	20.0	40.0	60.0
Coil Length (includes connector module)	mm	305.5	545.5	785.5
	in	12.027	21.476	30.925
Attractive Force	N	7117	14234	21351
	lbf	1600	3200	4800
Electrical Cycle Length	mm	60	60	60
	in	2.3622	2.3622	2.3622

### MODULAR TRACKS

R16-180-M-X  
R16-240-M-X

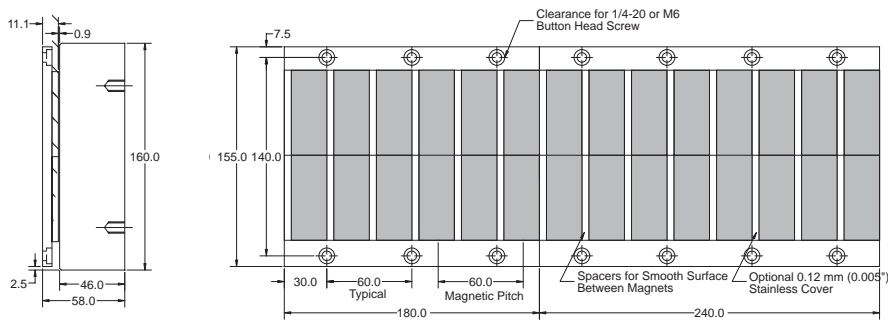

**Incremental Length:**  
60.0mm (2.3622")

**Minimum Length:**  
180.0mm (7.0866")

**Weight:**  
11.34Kg/m (7.60lbs/ft)

R16-180-M-N (Nickel Plated Magnets)

R16-240-M-N (Nickel Plated Magnets)

R16-180-COVER (Optional)

R16-240-COVER (Optional)

### COIL ASSEMBLY

R16-xA-NC-Mx

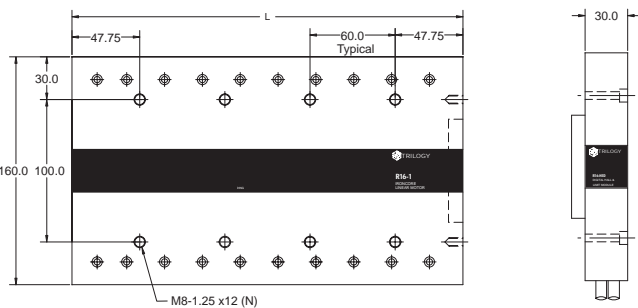

### R16 COIL ASSEMBLY

R16-xA-NC-Mx	L	N	OAL
R16-1A-NC-Mx	275.5	8	305.5
R16-2A-NC-Mx	515.5	16	545.5
R16-3A-NC-Mx	755.5	24	785.5

R16-1A-NC-MS

Series Winding

R16-2A-NC-MS or -MP

Series or Parallel Winding

R16-3A-NC-MS or -MT

Series or Triple Winding

### CONNECTOR MODULE

R16-xxx-Rx-x

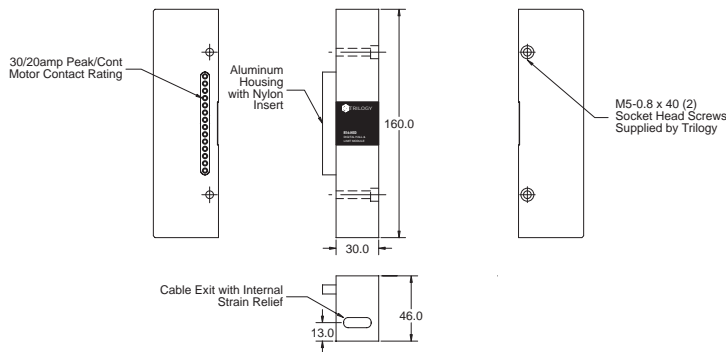

### R16 CONNECTOR MODULE

R16-xxx-Rx-x

Motor Connector

Digital HED's

Limit Sensors

R16-CM-Rx-x

✓

R16-HED-Rx-x

✓

✓

✓

R16-xxx-RS-1 or -RP-1 or -RT-1: 1m cable standard.

Module and Coil Assembly winding (S, P or T) must match.

### NOTES

- Peak force for the R16 is not limited by the temperature rise. Using the peak current at a 6.4% duty cycle results in the maximum temperature rise.
- The force constant gradually decreases at high current levels. At the peak current the force constant is reduced by 27%. Refer to [www.trilogysystems.com](http://www.trilogysystems.com) for motor performance curves at different current levels. TIPS sizing software accommodates the changing force constant with current in its algorithms.
- Specifications are based on the maintaining the air gap between the coil and track shown in the drawings. Refer to [www.trilogysystems.com](http://www.trilogysystems.com) for motor performance curves at different air gaps.
- Continuous force and current based on coil winding temperature maintained at 100°C.
- Motor resistance measured between any two motor leads with motor connected in Wye winding at 25°C. For temperature at 100°C, multiply resistance by 1.295 (75°C rise \* 0.393%/°C).
- Thermal Resistance is the number of degrees (Celsius) of temperature rise in the winding per watt of power dissipated. Determined experimentally.
- Motor Constant is a measure of efficiency. Calculated by dividing the force constant by the square root of the motor resistance at maximum operating temperature.
- Use TIPS sizing software for the most accurate estimate of coil temperature for a particular motion profile.

### SAFETY

- USE EXTREME CAUTION IN HANDLING TRACKS. Ironcore Linear Motors contain exposed magnets and have an open magnetic field. Any ferrous metal, steel or iron, will be attracted to the magnet track. The amount of attractive force increases significantly as the distance from the magnet decreases. Severe injury may occur to fingers or hands if caught between the track and coil or other metal object.
- USE EXTREME CAUTION WHEN INSTALLING THE COIL. The data sheet lists the attractive force between the coil and track. Refer to the "Motor Installation Guide" for proper installation instructions.
- ANY PERSON WITH MEDICAL ELECTRONIC IMPLANTS SHOULD USE EXTREME CAUTION WHEN NEAR AN OPEN MAGNETIC FIELD. The magnetic field could interfere with the medical device's operation.
- ANY PERSON WORKING OR HANDLING THE TRACKS SHOULD REMOVE PERSONAL EFFECTS. Items such as jewelry, watches, keys and credit cards may be damaged or adversely affected by the magnetic field.



### Motor Coil:

Order Example:

R7 - 1 A - NC - M S

**Series**  
R5, R7, R9, R10, R16

**Coil size**  
1, 2 or 3 poles

**Mounting Type**  
A standard top mount  
C custom

**Winding type**  
S series  
P parallel (R7-2 only)  
T triple (R7-3 only)

**Module ready**  
receives connector module

**Cooling**  
NC no cooling  
AC not available  
\*LC not available

\*Consult factory for water cooling options.

### Magnet Track:

Order Example:

R7 - 240 M - N

**Series**  
R5, R7, R9, R10, R16

**Track length**  
160 mm or 240 mm for R5, R7 and R9  
180 mm or 240 mm for R10 and R16

**Magnet coating**  
N nickel

**Mounting**  
M modular  
C custom

### Connector Module:

Order Example:

R7 - CM - R S - 1

**Series**  
R5, R7, R9, R10, R16

**Device description**  
CM connector module  
HED Hall effects device with limits

**Module type**

**Cable length**  
1 meter (standard)

**Module winding**  
S series  
P parallel  
T triple  
(must correspond to coil winding)

# Industrial Grade Linear Motor Positioners

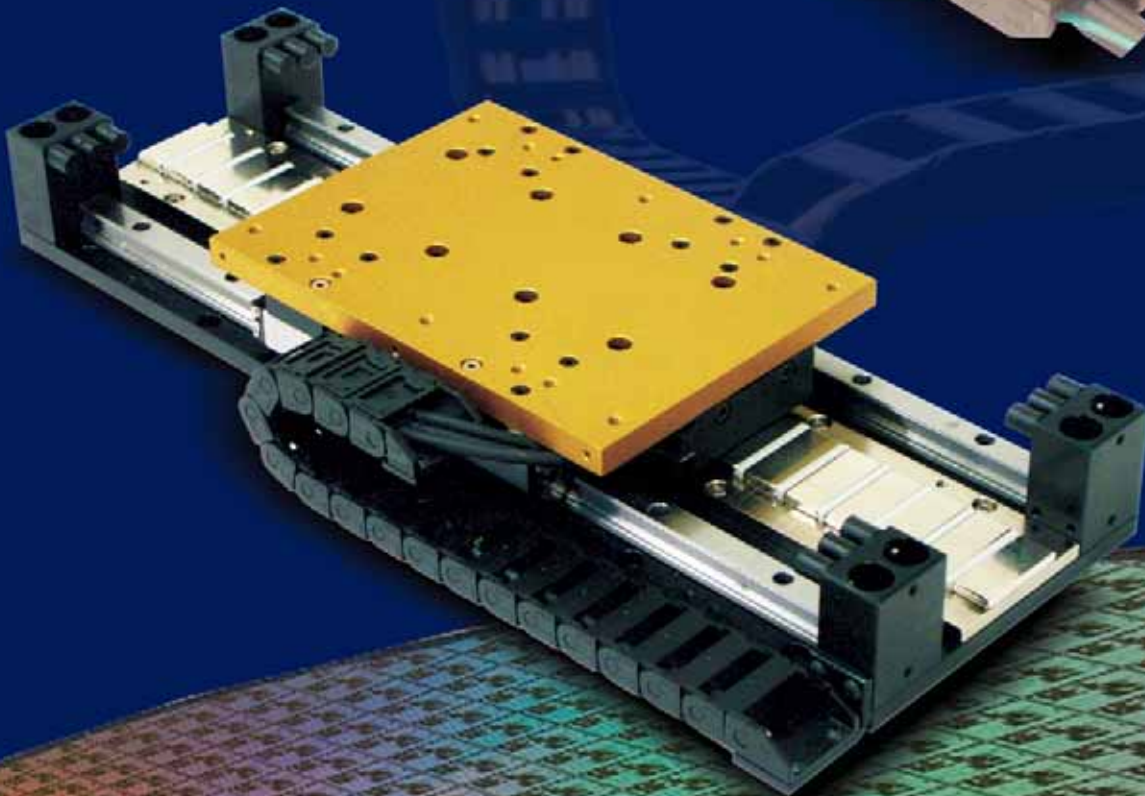

# I-FORCE Ironless Linear Positioners

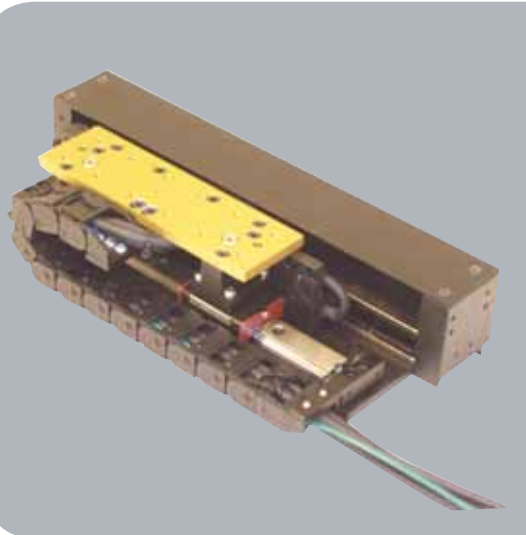

Parker Trilog's I-Force linear positioners utilize our high-performance I-Force ironless linear motors in a pre-engineered, easily integrated, ready-to-run package. The principal design goal for these positioners is to achieve high performance at an economical cost while preserving the design flexibility to accommodate customization.

Trilog's positioners have selectable single- or dual-bearing to match the performance and cost requirements for each application. In addition, they are designed to connect together using transition plates for XY or multi-axis configurations. Options include a variety of cable management systems in addition to bellows and hard covers.

Flexibility, multi-axis compatibility, and ease of customization make the I-Force linear positioners a superior choice for high performance and value.

- Trilog positioners use ground steel or aluminum bases for flatness and parallelism because aluminum extrusions often do not meet the accuracy requirements for straightness and flatness.
- Trilog has single- or dual-bearing rail positioners to better match the performance and cost requirements for each application.
- Every positioner includes a magnetic encoder for industrial environments or an optical encoder with resolutions down to 0.1um (0.000 04").
- Dual-rail positioners have bellows as a standard option.
- Multiple carriage options are available on all positioner series.
- Different cable track widths available for added stiffness and rigidity
- Different cable track widths available as custom options for user payload tubes and cables

PERFORMANCE		LINEAR MAGNETIC ENCODER		RENISHAW ENCODER OPTIONS (Note 5)	
		5.0µm	1.0µm	0.5µm	0.1µm
Peak Velocity	in/s [m/s]	275 [7]	100 [2.5]	120 [3]	15 [0.4]
Resolution	in [µm]	0.0002 [5]	0.000 04 [1.0]	0.000 02 [0.5]	0.000 004 [0.1]
Repeatability	in [µm]	±0.0004 [±10]	±0.000 8 [2.0]	±0.000 06 [1.5]	±0.000 04 [1.0]
Accuracy – LME		±(30µm +50µm/m) ±(25µm +50µm/m)			
Accuracy – Renishaw				±(5µm +30µm/m)	

Note: For travels less than 1 meter, accuracy should be calculated at 1 meter

MOTOR MODEL		110-1	110-2
Peak Force	N	108.5	202.5
	lb	24.4	45.5
Continuous Force	N	24.5	45.4
	lb	5.5	10.2
Peak Power	W	938	1641
Continuous Power	W	47	82

ACCURACY	STANDARD	LASER ALIGNMENT OPTION
Straightness restrained on flat surface in [µm]	±0.000127 in/in [±127µm/m]	±0.000127 in/in
Flatness restrained on flat surface in [µm]	±0.013 [±330]	

Note: Straightness/Flatness specifications based on system mounted to surface of flatness ±0.0005in/ft

LOAD		- 1	- 2
Vertical (Fv) see note 11	lbs [kg]	30 [13, 5]	30 [13, 5]
Side (Fs) see note 11	lbs [kg]	15 [6, 8]	15 [6, 8]
Moments–Roll (Mr) see note 11	lb-ft [N-m]	15 [20]	15 [20]
Moments–Pitch (Mp) see note 11	lb-ft [N-m]	52 [70]	52 [70]
Moments–Yaw (My) see note 11	lb-ft [N-m]	52 [70]	52 [70]

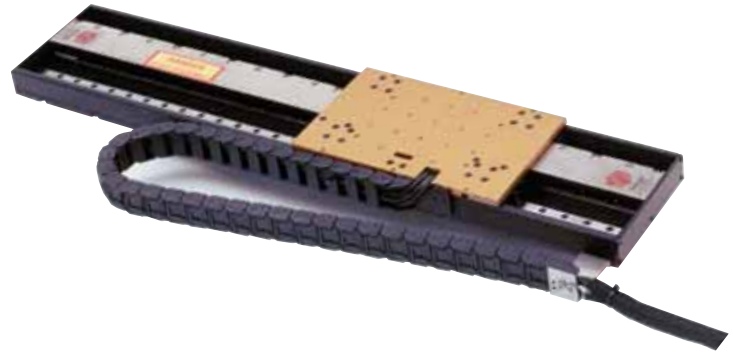

Dimensions shown in inches.

● Moving Carriage Assembly

● Stationary Base Assembly

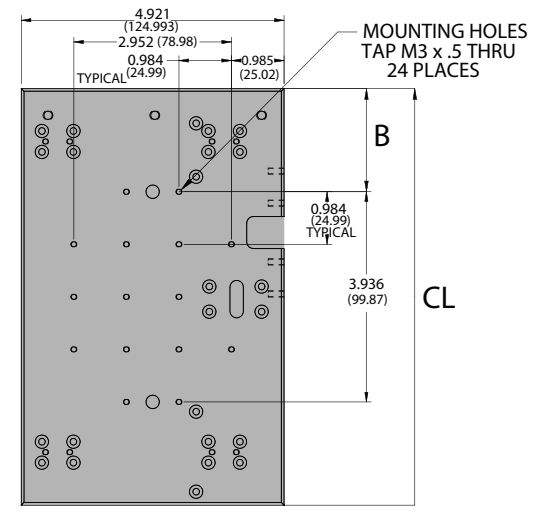
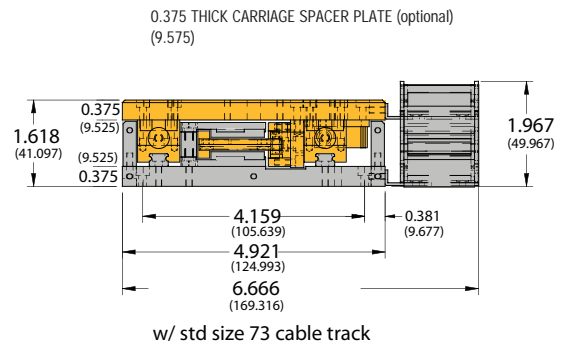
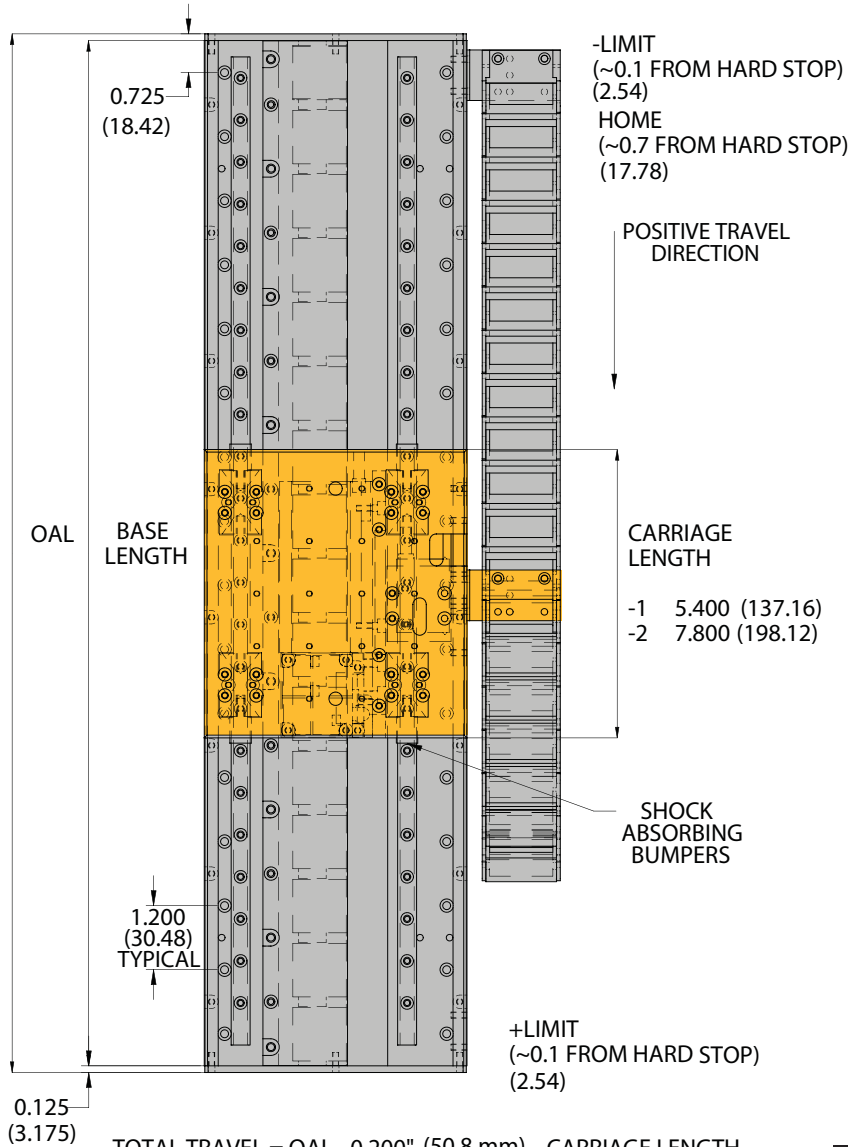

TOTAL TRAVEL = OAL - 0.200" (50.8 mm) - CARRIAGE LENGTH  
 OAL = BASE LENGTH + 0.250" (6.35 mm)  
 BASE LENGTH = MULTIPLE OF 2.400" (60.96)

CARRIAGE SIZE				
	-1	mm	-2	mm
CL	5.400	137.16	7.800	198.12
B	0.732	18.59	1.932	49.07
Coil	110-1	110-1	110-2	110-2

PERFORMANCE		LINEAR MAGNETIC ENCODER		RENISHAW ENCODER OPTIONS (Note 5)	
		5.0µm	1.0µm	0.5µm	0.1µm
Peak Velocity	in/s [m/s]	275 [7]	100 [2.5]	120 [3]	15 [0.4]
Resolution	in [µm]	0.0002 [5]	0.000 04 [1.0]	0.000 02 [0.5]	0.000 004 [0.1]
Repeatability	in [µm]	±0.0004 [±10]	±0.000 8 [2.0]	±0.000 06 [1.5]	±0.000 04 [1.0]
Accuracy – LME		±(30µm +50µm/m)			
Accuracy – Renishaw				±(5µm +30µm/m)	

Note: For travels less than 1 meter, accuracy should be calculated at 1 meter

MOTOR MODEL		110-1	110-2
Peak Force	N	108.5	202.5
	lb	24.4	45.5
Continuous Force	N	24.5	45.4
	lb	5.5	10.2
Peak Power	W	938	1641
Continuous Power	W	47	82

ACCURACY	STANDARD	LASER ALIGNMENT OPTION
Straightness restrained on flat surface in [µm]	±0.000127 in/in [±127µm/m]	±.000013 in/in [±13 µm/m]
Flatness restrained on flat surface in [µm]	±0.013 [±330]	

Note: Straightness/Flatness specifications based on system mounted to surface of flatness ±0.0005in/ft

PHYSICAL		- 2	- 3
Carriage Assembly	lbs [kg]	1.10 [0,50]	1.50 [0,68]
Base Assembly			
T1SD Aluminum (0.250" thick)	lbs/ft [kg/m]	2.25 [3,35]	.....▶
T1SA Aluminum (0.375" thick)	lbs/ft [kg/m]	2.78. [4,13]	.....▶
Carriage Length	in [mm]	3.40 [86,4]	5.80 [147,3]
Coil Bar Length	in [mm]	3.20 [81,3]	5.60 [142,2]

LOAD		- 1	- 2
Vertical (Fv) see note 11	lbs [kg]	25 [11, 3]	25 [11, 3]
Side (Fs) see note 11	lbs [kg]	13 [5, 7]	13 [5, 7]
Moments–Roll (Mr) see note 11	lb-ft [N-m]	11 [15]	11 [15]
Moments–Pitch (Mp) see note 11	lb-ft [N-m]	44 [60]	44 [60]
Moments–Yaw (My) see note 11	lb-ft [N-m]	44 [60]	44 [60]

**NOTES**

- Total travel (in) = BASE LENGTH - 1.6 (40.64 mm) - CARRIAGE LENGTH.
- Maximum base length is 40.8", 1m
- Aluminum base is black anodized.
- For complete motor specifications, refer to 110 series motor data sheet.
- Renishaw encoder, RGH24 series, available in 0.05µm, 0.1µm, 0.5µm, 1.0µm, 5.0µm.
- Standard cable track provided is Igus 07.20.018.
- Specification subject to change without notice.
- Listed specifications based on motor size and typical performance requirements. Bearing manufacturer specifications exceed listed specifications.

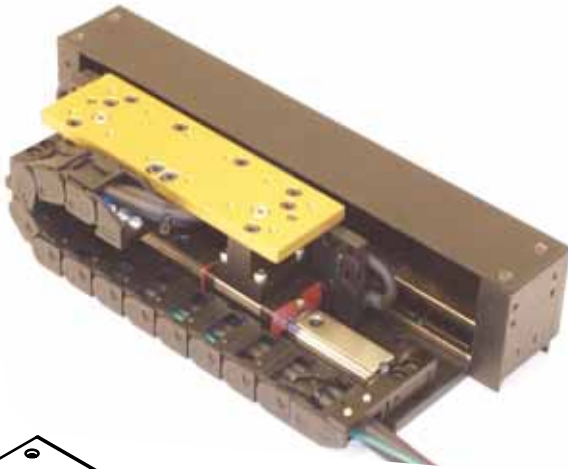

# T1S

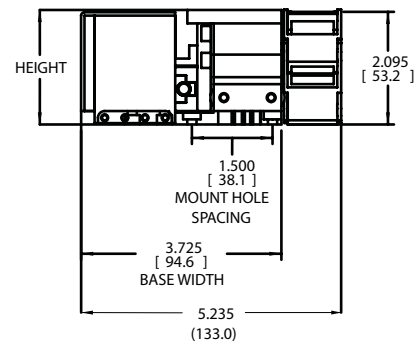
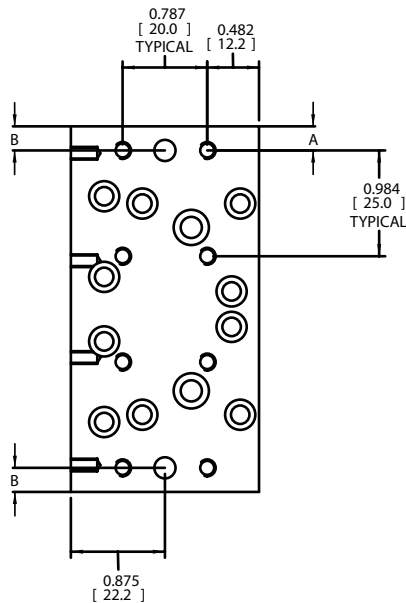
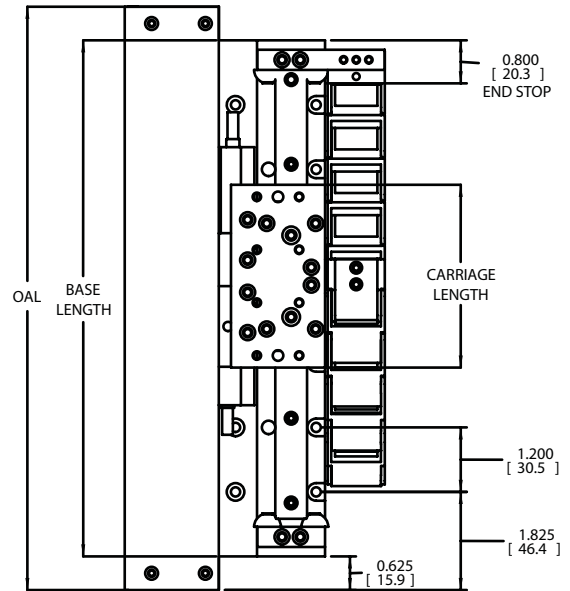
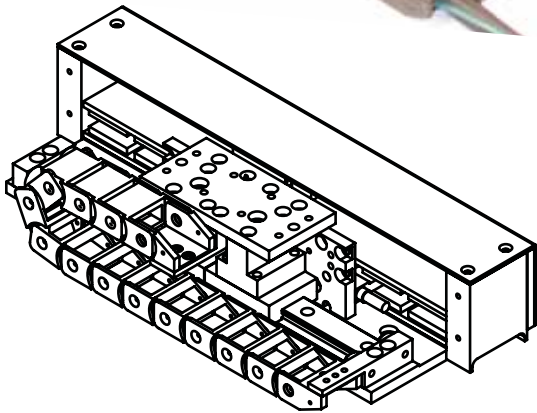

OAI = BASE LENGTH + 1.25 IN (31.75)  
 TRAVEL = BASE LENGTH - 1.6 - CARRIAGE LENGTH  
 TRAVEL (mm) = BASE LENGTH - 40.64 - CARRIAGE LENGTH

CARRIAGE TABLE		
COIL SIZE	-1	-2
CARRIAGE LENGTH	3.4 [86.4]	5.8 [147.3]
A (1ST MOUNTING HOLE)	0.224 [5.7]	0.440 [11.2]
B (DOWEL PIN HOLE)	0.224 [5.7]	0.440 [11.2]



PERFORMANCE		LINEAR MAGNETIC ENCODER		RENISHAW ENCODER OPTIONS (Note 5)	
		5.0µm	1.0µm	0.5µm	0.1µm
Peak Velocity	in/s [m/s]	275 [7]	100 [2.5]	120 [3]	15 [0.4]
Resolution	in [µm]	0.0002 [5]	0.000 04 [1.0]	0.000 02 [0.5]	0.000 004 [0.1]
Repeatability	in [µm]	±0.0004 [±10]	±0.000 8 [2.0]	±0.000 06 [1.5]	±0.000 04 [1.0]
Accuracy – LME		±(30µm +50µm/m)		±(25µm +50µm/m)	
Accuracy – Renishaw		±(5µm +30µm/m)			

*Note: For travels less than 1 meter, accuracy should be calculated at 1 meter*

MOTOR MODEL		210-2	210-3	210-4
Peak Force	N	255.8	375.0	494.2
	lb	57.5	84.3	111.1
Continuous Force	N	57.4	84.1	110.3
	lb	12.9	18.9	24.8
Peak Power	W	1583	2261	2940
Continuous Power	W	79	113	147

ACCURACY	STANDARD	LASER ALIGNMENT OPTION
Straightness restrained on flat surface in [µm]	±0.000127in/in [±127µm/m]	±0.0000127 in/in [±13µm/m]
Flatness restrained on flat surface in [µm]	±0.003 + 000254 in/in [±76 + 254µm/m]	

*Note: For travels less than 1 meter, Flatness should be calculated at 1 meter  
Straightness/Flatness specifications based on system mounted to surface of flatness ±0.0005in/ft*

PHYSICAL		- 2	- 3	- 4
Carriage Assembly	lbs [kg]	3.10 [1,4]	4.10 [2,1]	5.50 [2,5]
Base Assembly				
T2DA Aluminum (0.375" thick)	lbs/ft [kg/m]	10.80 [16,1]		
T2DB Aluminum (0.500" thick)	lbs/ft [kg/m]	11.70 [17,4]		
T2DS Steel (0.500" thick)	lbs/ft [kg/m]	18.10 [26,9]	.....▶	.....▶
Carriage Length	in [mm]	4.20 [106,7]	6.60 [167,6]	9.00 [228,6]
Coil Bar Length	in [mm]	7.20 [182,9]	9.60 [243,8]	12.00 [304,8]

LOAD		- 2	- 3	- 4
Vertical (Fv) see note 11	lbs [kg]	60 [27,1]	80 [36,3]	100 [45,3]
Side (Fs) see note 11	lbs [kg]	40 [18,1]	60 [27,2]	60 [27,2]
Moments–Roll (Mr) see note 11	lb-ft [N-m]	40 [53]	60 [80]	60 [80]
Moments–Pitch (Mp) see note 11	lb-ft [N-m]	100 [134]	200 [270]	200 [270]
Moments–Yaw (My) see note 11	lb-ft [N-m]	100 [134]	200 [270]	200 [270]

**NOTES**

- Total travel = OAL – 3.00" (76.2 mm) – carriage length.
- Maximum base length is 120" (3048 mm).
- Aluminum base is black anodized. Steel base is nickel plated.
- For complete motor specifications, refer to 210 series motor data sheet.
- Renishaw encoder, RGH24 series, available in 0.05µm, 0.1µm, 0.5µm, 1.0µm, 5.0µm.
- Cables extend past base by approximately 0.6" when carriage is at negative hard stop.
- Cable Track extends 0.175" higher than carriage mounting surface. It is recommended to use optional Spacer Plate for custom mounting holes.
- Standard cable track provided is Igus 07.30.018.
- Base mounting holes are equidistant, 1.200" (12.0, 16.8, 21.6....) or 2.400" (9.6, 14.4, 19.2, 24.0....) from each end depending on base length.
- Specification subject to change without notice.
- Listed specifications based on motor size and typical performance requirements. Bearing manufacturer specifications exceed listed specifications.





Dimensions shown in inches.

● Moving Carriage Assembly

● Stationary Base Assembly

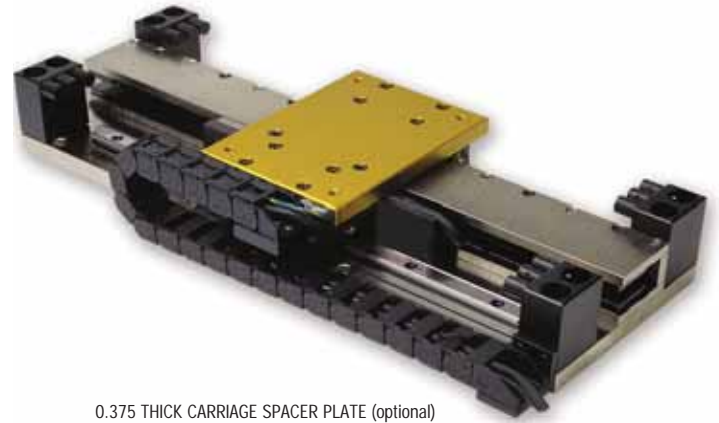

0.375 THICK CARRIAGE SPACER PLATE (optional)  
(9.525)

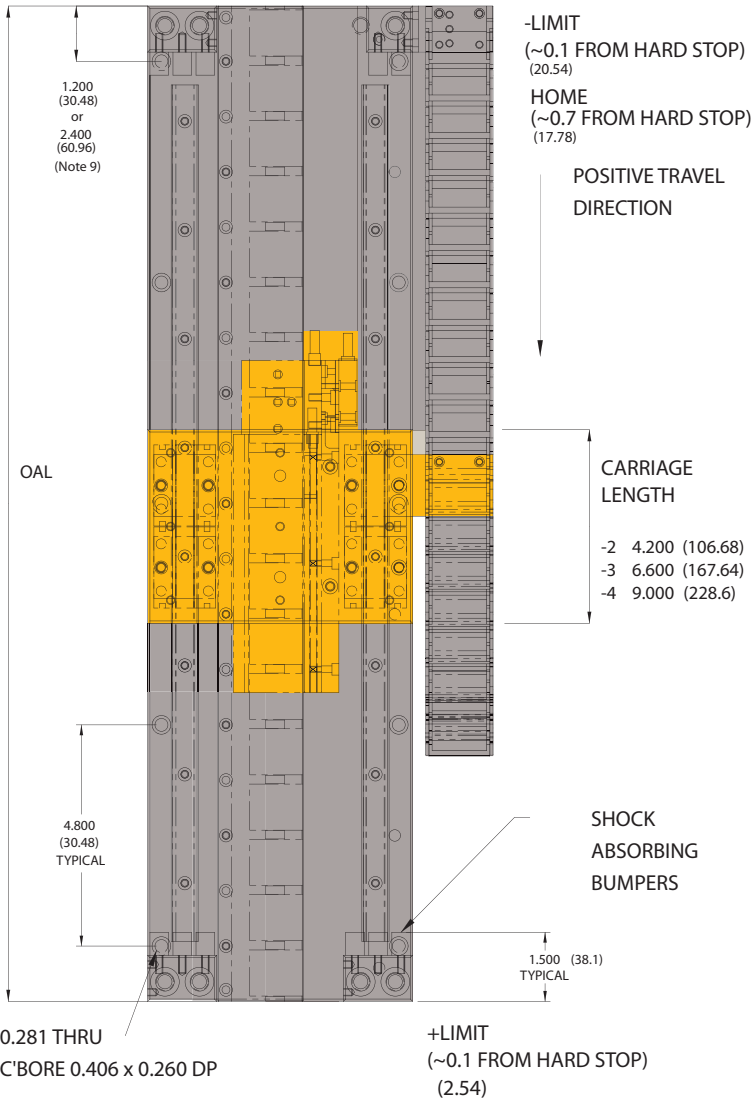
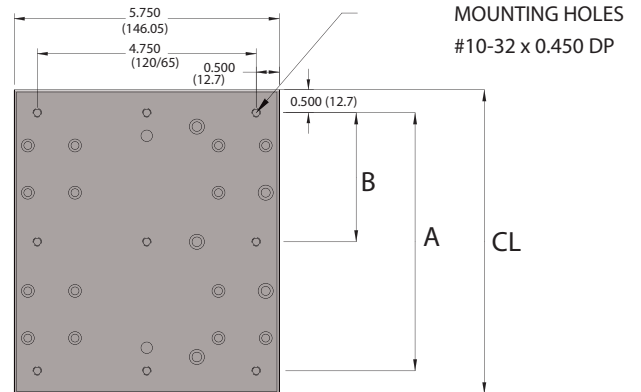
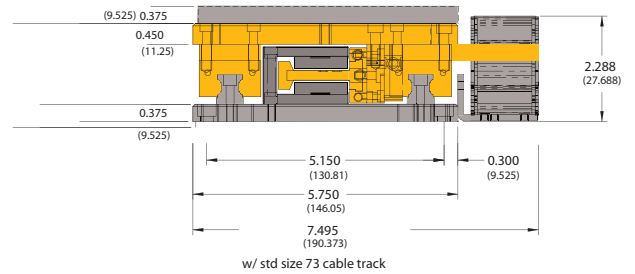

TOTAL TRAVEL = OAL - 3.00" (76.2 mm) - CARRIAGE LENGTH

OAL = MULTIPLE OF 2.400" (60.96)

	CARRIAGE SIZE					
	- 2 mm		- 3 mm		- 4 mm	
CL	4.200	106.68	6.600	167.64	9.000	228.6
A	3.200	81.28	5.600	142.24	8.000	203.80
B	—	—	2.800	71.12	4.000	101.60
COIL	210-2		210-3		210-4	

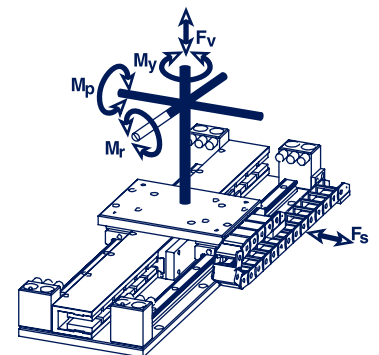

PERFORMANCE		LINEAR MAGNETIC ENCODER		RENISHAW ENCODER OPTIONS (Note 5)	
		5.0µm	1.0µm	0.5µm	0.1µm
Peak Velocity	in/s [m/s]	275 [7]	100 [2.5]	120 [3]	15 [0.4]
Resolution	in [µm]	0.0002 [5]	0.000 04 [1.0]	0.000 02 [0.5]	0.000 004 [0.1]
Repeatability	in [µm]	±0.0004 [±10]	±0.000 8 [2.0]	±0.000 06 [1.5]	±0.000 04 [1.0]
Accuracy – LME		±(30µm +50µm/m)			
Accuracy – Renishaw				±(5µm +30µm/m)	

Note: For travels less than 1 meter, accuracy should be calculated at 1 meter

MOTOR MODEL		210-2	210-3	210-4
Peak Force	N	255.8	375.0	494.2
	lb	57.5	84.3	111.1
Continuous Force	N	57.4	84.1	110.3
	lb	12.9	18.9	24.8
Peak Power	W	1583	2261	2940
Continuous Power	W	79	113	147

ACCURACY		STANDARD	LASER ALIGNMENT OPTION
Straightness restrained on flat surface in [µm]		±0.000127 in/m [±127mm/m]	±0.0000127 in/in [±13mm/m]
Flatness restrained on flat surface in [µm]		±0.003 +.000254 in/in [±76 + 254µm/m]	

Note: For travels less than 1 meter, Flatness should be calculated at 1 meter

Straightness/Flatness specifications based on system mounted to surface of flatness ±0.0005in/ft

PHYSICAL		- 2	- 3	- 4	
Carriage Assembly	lbs [kg]	2.10 [0,95]	3.10 [1,38]	3.80 [1,70]	
Base Assembly			.....▶.....▶.....▶	.....▶.....▶.....▶	
	T2SA Aluminum (0.375" thick)	lbs/ft [kg/m]	9.10 [13,5]	.....▶.....▶.....▶	.....▶.....▶.....▶
	T2SB Aluminum (0.500" thick)	lbs/ft [kg/m]	9.90 [14,7]	.....▶.....▶.....▶	.....▶.....▶.....▶
T2SS Steel (0.500" thick)	lbs/ft [kg/m]	15.10 [22,5]	.....▶.....▶.....▶	.....▶.....▶.....▶	
Carriage Length	in [mm]	4.20 [106,7]	6.60 [167,6]	9.00 [228,6]	
Coil Bar Length	in [mm]	7.20 [182,9]	9.60 [243,8]	12.00 [304,8]	

LOAD		- 2	- 3	- 4
Vertical (Fv) see note 11	lbs [kg]	40 [18,1]	50 [22,7]	60 [27,2]
Side (Fs) see note 11	lbs [kg]	20 [9,1]	30 [13,6]	30 [13,6]
Moments–Roll (Mr) see note 11	lb-ft [N-m]	20 [27]	30 [40]	30 [40]
Moments–Pitch (Mp) see note 11	lb-ft [N-m]	50 [67]	100 [135]	100 [135]
Moments–Yaw (My) see note 11	lb-ft [N-m]	50 [67]	100 [135]	100 [135]

NOTES

- Total travel = OAL – 3.00" (76.2 mm) – carriage length.
- Maximum base length is 120" (3048 mm).
- Aluminum base is black anodized. Steel base is nickel plated.
- For complete motor specifications, refer to 210 series motor data sheet.
- Renishaw encoder, RGH24 series, available in 0.05µm, 0.1µm, 0.5µm, 1.0µm, 5.0µm.
- Cable extends past base by approximately 0.6" when carriage is at negative hard stop.
- Cable Track extends 0.175" higher than carriage mounting surface. It is recommended to use optional Spacer Plate for custom mounting holes.
- Standard cable track provided is Igus 07.30.018.
- Base mounting holes are equidistant, 1.200" (12.0, 16.8, 21.6...) or 2.400" (9.6, 14.4, 19.2, 24.0...) from each end depending on base length.
- Specification subject to change without notice.
- Listed specifications based on motor size and typical performance requirements. Bearing manufacturer specifications exceed listed specifications.





Dimensions shown in inches.

● Moving Carriage Assembly

● Stationary Base Assembly

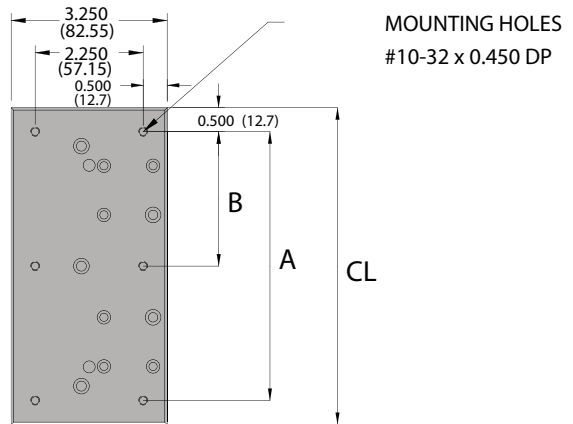
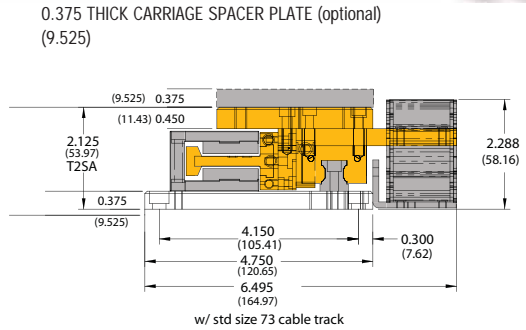
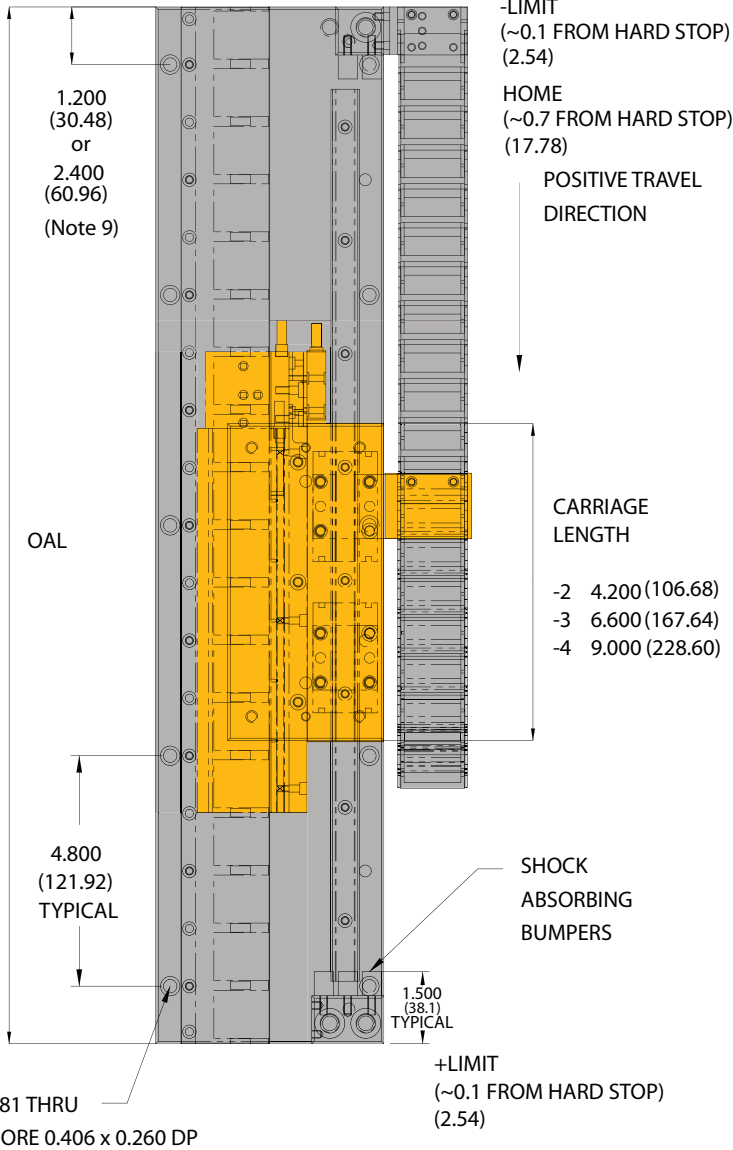
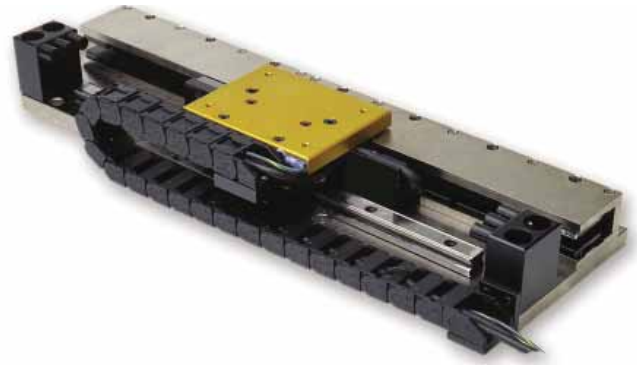

TOTAL TRAVEL = OAL - 3.00" - CARRIAGE LENGTH  
 = OAL - 76.2 mm - CARRIAGE LENGTH  
 OAL = MULTIPLE OF 2.400" (60.96)

	CARRIAGE SIZE					
	- 2	mm	- 3	mm	- 4	mm
CL	4.200	106.68	6.600	167.64	9.000	228.60
A	3.200	81.28	5.600	142.24	8.000	203.20
B	—	71.12	2.800	101.60	4.000	101.64
COIL	210-2		210-3		210-4	

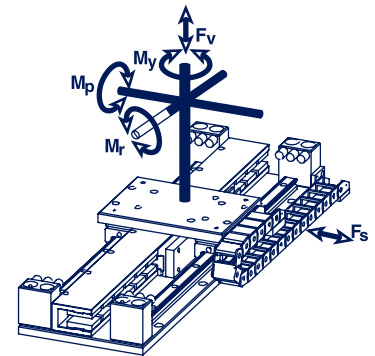

PERFORMANCE		LINEAR MAGNETIC ENCODER		RENISHAW ENCODER OPTIONS (Note 5)	
		5.0µm	1.0.1µm	0.5µm	0.1µm
Peak Velocity	in/s [m/s]	275 [7]	100 [2.5]	120 [3]	15 [0.4]
Resolution	in [µm]	0.0002 [5]	0.000 04 [1.0]	0.000 02 [0.5]	0.000 004 [0.1]
Repeatability	in [µm]	±0.0004 [±10]	±0.000 8 [2.0]	±0.000 06 [1.5]	±0.000 04 [1.0]
Accuracy – LME		±(30µm +50µm/m)		±(25µm +50µm/m)	
Accuracy – Renishaw		±(5µm +30µm/m)			

Note: For travels less than 1 meter, accuracy should be calculated at 1 meter

MOTOR MODEL		310-2	310-3	310-4	310-5	310-6
Peak Force	N	409.3	600.0	790.0	980.0	1170.0.1
	lb	92.0	135.1	177.2	220.3	263.2
Continuous Force	N	91.6	133.9	176.2	219.3	262.0
	lb	20.6	30.1	39.6	49.3	58.9
Peak Power	W	1885	2693	3500	4308	5116
Continuous Power	W	4	135	179	215	256

ACCURACY		STANDARD	LASER ALIGNMENT OPTION
Straightness restrained on flat surface in [µm]		±0.000127in/in [ ±127µm/m]	±.000013 in/in [13µm/m]
Flatness restrained on flat surface in [µm]		±0.003 + .000254 in/in [±76 + 254µm/m]	

Note: For travels less than 1 meter, Flatness should be calculated at 1 meter

Straightness/Flatness specifications based on system mounted to surface of flatness ±0.0005in/ft

PHYSICAL		- 2	- 3	- 4	- 5	- 6
Carriage Assembly	lbs [kg]	4.60 [2,1]	6.70 [3,0]	8.10 [3,7]	9.50 [4,3]	11.00 [5,0]
Base Assembly						
T3DA Aluminum (3.375" thick)	lbs/ft [kg/m]	15.75 [23,4]	.....▶	.....▶	.....▶	.....▶
T3DB Aluminum (0.500" thick)	lbs/ft [kg/m]	16.88 [25,1]	.....▶	.....▶	.....▶	.....▶
T3DS Steel (0.500" thick)	lbs/ft [kg/m]	25.27 [37,6]	.....▶	.....▶	.....▶	.....▶
Carriage Length	in [mm]	4.20 [106,7]	6.60 [167,6]	9.00 [228,6]	11.40 [289,6]	13.80 [350,5]
Coil Bar Length	in [mm]	7.20 [182,9]	9.60 [243,8]	12.00 [304,8]	14.40 [365,8]	16.80 [426,7]

LOAD		- 2	- 3	- 4	- 5	- 6
Vertical (Fv) see note 11	lbs [kg]	120 [54]	150 [68]	180 [81]	210 [95]	240 [108]
Side (Fs) see note 11	lbs [kg]	80 [36]	100 [45]	100 [45]	100 [45]	100 [45]
Moments–Roll (Mr) see note 11	lb-ft [N-m]	80 [107]	100 [134]	100 [134]	100 [134]	100 [134]
Moments–Pitch (Mp) see note 11	lb-ft [N-m]	160 [214]	300 [402]	300 [402]	300 [402]	300 [402]
Moments–Yaw (My) see note 11	lb-ft [N-m]	160 [214]	300 [402]	300 [402]	300 [402]	300 [402]

### NOTES

- Total travel = OAL – 3.00" (76.2 mm) – carriage length.
- Maximum base length is 120" (3048 mm).
- Aluminum base is black anodized. Steel base is nickel plated.
- For complete motor specifications, refer to 310 series motor data sheet.
- Renishaw encoder, RG24 series, available in 0.05.0µm, 0.1µm, 0.5µm, 1.0µm, 5.0µm.
- Cable extends past base by approximately 0.6" when carriage is at negative hard stop.
- Cable Track extends 0.175" higher than carriage mounting surface. It is recommended to use optional Spacer Plate for custom mounting holes.
- Standard cable track provided is Igus 07.30.018.
- Base mounting holes are equidistant, 1.200" (12.0, 16.8, 21.6...) or 2.400" (9.6, 14.4, 19.2, 24.0...) from each end depending on base length.
- Specification subject to change without notice.
- Listed specifications based on motor size and typical performance requirements. Bearing manufacturer specifications exceed listed specifications.

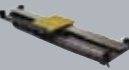

Dimensions shown in inches.

- Moving Carriage Assembly
- Stationary Base Assembly

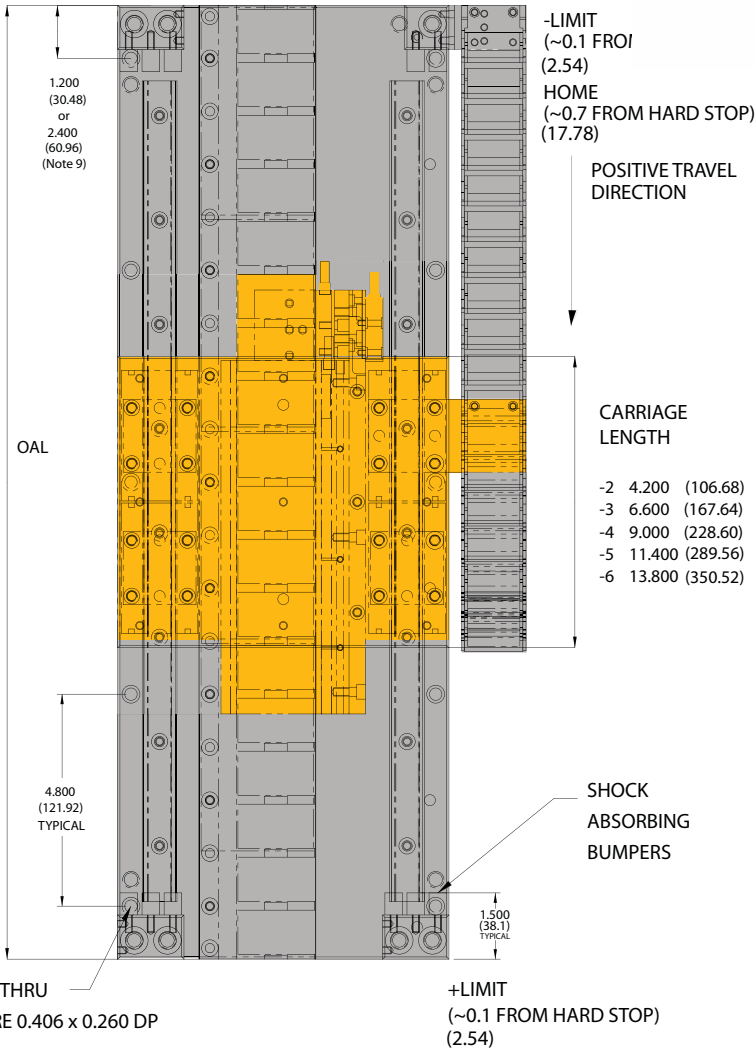
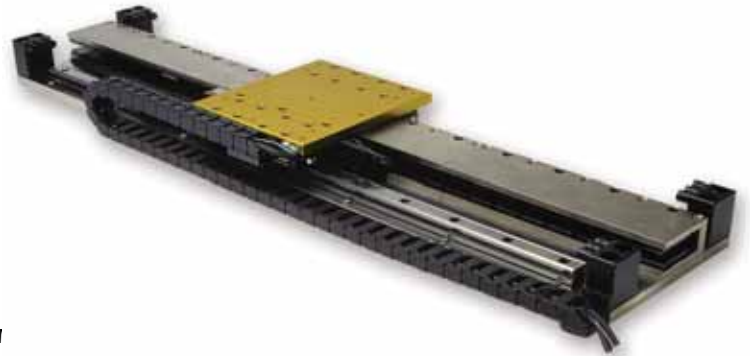

- CARRIAGE LENGTH
- 2 4.200 (106.68)
  - 3 6.600 (167.64)
  - 4 9.000 (228.60)
  - 5 11.400 (289.56)
  - 6 13.800 (350.52)

TOTAL TRAVEL = OAL - 3.00" (76.2) - CARRIAGE LENGTH  
OAL = MULTIPLE OF 2.400" (60.96)

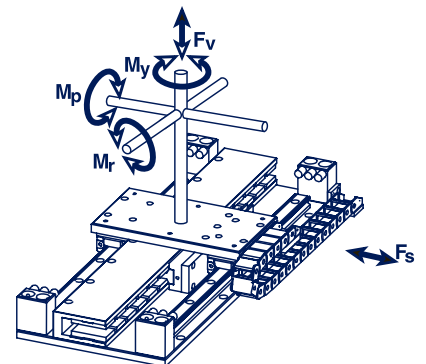
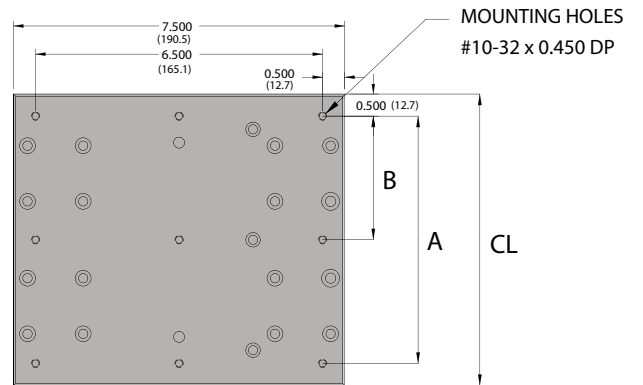
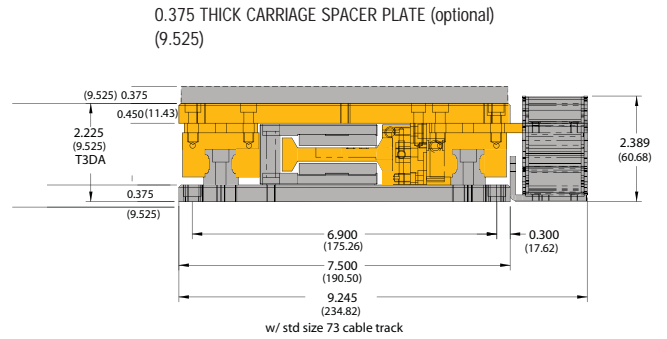

CARRIAGE SIZE										
	-2	mm	-3	mm	-4	mm	-5	mm	-6	mm
CL	4.200	106.68	6.600	167.64	9.000	228.60	11.400	289.56	13.800	350.52
A	3.200	81.28	5.650	142.24	8.000	203.20	10.400	264.16	12.800	325.12
B	—		2.800	71.12	4.000	101.60	5.200	132.08	6.400	162.56
COIL	310-2		310-3		310-4		310-5		310-6	



PERFORMANCE		LINEAR MAGNETIC ENCODER		RENISHAW ENCODER OPTIONS (Note 5)	
		5.0µm	1.0.1µm	0.5µm	0.1µm
Peak Velocity	in/s [m/s]	275 [7]	100 [2.5]	120 [3]	15 [0.4]
Resolution	in [µm]	0.0002 [5]	0.000 04 [1.0]	0.000 02 [0.5]	0.000 004 [0.1]
Repeatability	in [µm]	±0.0004 [±10]	±0.000 8 [2.0]	±0.000 06 [1.5]	±0.000 04 [1.0]
Accuracy – LME		±(30µm + 50µm/m)		±(25µm + 50µm/m)	
Accuracy – Renishaw		±(5µm + 30µm/m)			

Note: For travels less than 1 meter, accuracy should be calculated at 1 meter

MOTOR MODEL		310-2	310-3	310-4	310-5	310-6
Peak Force	N	409.3	600.0	790.0	980.0	1170.0
	lb	92.0	135.1	177.2	220.3	263.2
Continuous Force	N	91.6	133.9	176.2	219.3	262.0
	lb	20.6	30.1	39.6	49.3	58.9
Peak Power	W	1885	2693	3500	4308	5116
Continuous Power	W	4	135	179	215	256

ACCURACY	STANDARD	LASER ALIGNMENT OPTION
Straightness restrained on flat surface in [µm]	±0.000127 [±127µm/m]	±.00013 in/in [±13µm/m]
Flatness restrained on flat surface in [µm]	±0.003 + .00254 in/in [±76 + 254µm/m]	

Note: For travels less than 1 meter, Flatness should be calculated at 1 meter

Straightness/Flatness specifications based on system mounted to surface of flatness ±0.0005in/ft

PHYSICAL		- 2	- 3	- 4	- 5	- 6
Carriage Assembly	lbs [kg]	3.00 [1,4]	4.40 [2,0]	5.50 [2,5]	6.40 [2,9]	7.40 [3,3]
Base Assembly						
T3SA Aluminum (3.375" thick)	lbs/ft [kg/m]	13.30 [19,8]	.....▶	.....▶	.....▶	.....▶
T3SB Aluminum (0.500" thick)	lbs/ft [kg/m]	14.25 [21,2]	.....▶	.....▶	.....▶	.....▶
T3SS Steel (0.500" thick)	lbs/ft [kg/m]	21.24 [31,6]	.....▶	.....▶	.....▶	.....▶
Carriage Length	in [mm]	4.20 [106,7]	6.60 [167,6]	9.00 [228,6]	11.40 [289,6]	13.80 [350,5]
Coil Bar Length	in [mm]	7.20 [182,9]	9.60 [243,8]	12.00 [304,8]	14.40 [365,8]	16.80 [426,7]

LOAD		- 2	- 3	- 4	- 5	- 6
Vertical (Fv) see note 11	lbs [kg]	80 [36]	100 [45]	120 [54]	140 [63]	160 [72]
Side (Fs) see note 11	lbs [kg]	30 [13]	50 [22]	50 [22]	50 [22]	50 [22]
Moments–Roll (Mr) see note 11	lb-ft [N-m]	35 [47]	50 [67]	50 [67]	50 [67]	50 [67]
Moments–Pitch (Mp) see note 11	lb-ft [N-m]	75 [100]	150 [201]	150 [201]	150 [201]	150 [201]
Moments–Yaw (My) see note 11	lb-ft [N-m]	75 [100]	150 [201]	150 [201]	150 [201]	150 [201]

### NOTES

- Total travel = OAL – 3.00" (76.2 mm) – carriage length.
- Maximum base length is 120" (3048 mm).
- Aluminum base is black anodized. Steel base is nickel plated.
- For complete motor specifications, refer to 310 series motor data sheet.
- Renishaw encoder, RGH24 series, available in 0.05.0µm, 0.1µm, 0.5µm, 1.0µm, 5.0µm.
- Cable extends past base by approximately 0.6" when carriage is at negative hard stop.
- Cable Track extends 0.175" higher than carriage mounting surface. It is recommended to use optional Spacer Plate for custom mounting holes.
- Standard cable track provided is Igus 07.30.018.
- Base mounting holes are equidistant, 1.200" (12.0, 16.8, 21.6...) or 2.400" (9.6, 14.4, 19.2, 24.0...) from each end depending on base length.
- Specification subject to change without notice.
- Listed specifications based on motor size and typical performance requirements. Bearing manufacturer specifications exceed listed specifications.



Dimensions shown in inches.

● Moving Carriage Assembly

● Stationary Base Assembly

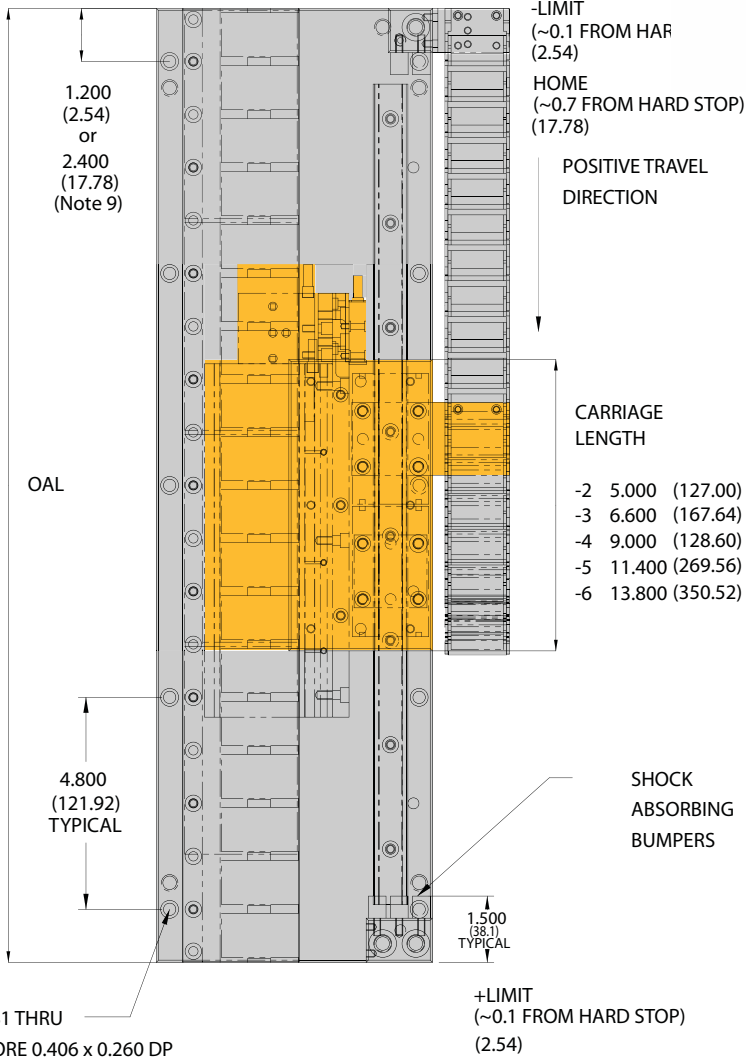
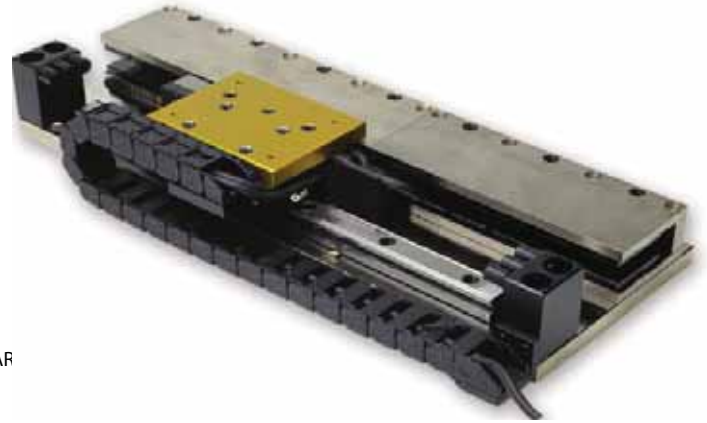

0.375 THICK CARRIAGE SPACER PLATE (optional) (9.525)

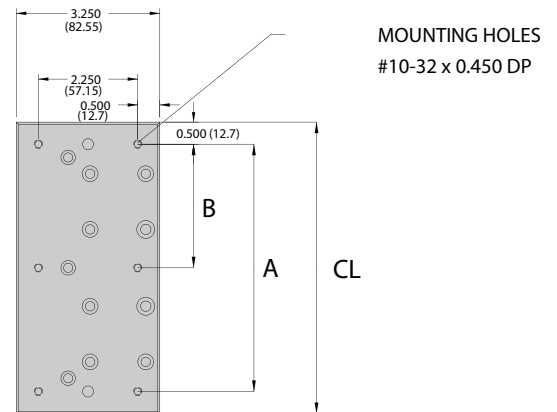
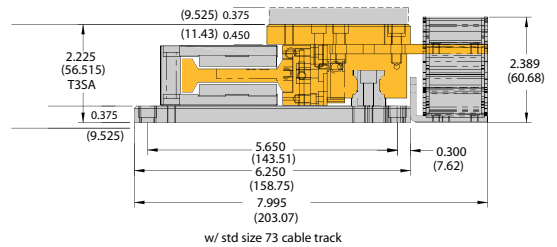

TOTAL TRAVEL = OAL - 3.00" (76.2) - CARRIAGE LENGTH  
OAL = MULTIPLE OF 2.400" (60.96)

CARRIAGE SIZE										
	-2	mm	-3	mm	-4	mm	-5	mm	-6	mm
CL	5.000	127.00	6.600	167.64	9.000	228.60	11.400	289.56	13.800	350.52
A	4.000	101.60	5.650	142.24	8.000	203.20	10.400	264.16	12.800	325.12
B	2.000	50.8	2.800	71.12	4.000	101.60	5.200	132.08	6.400	162.56
COIL	310-2		310-3		310-4		310-5		310-6	

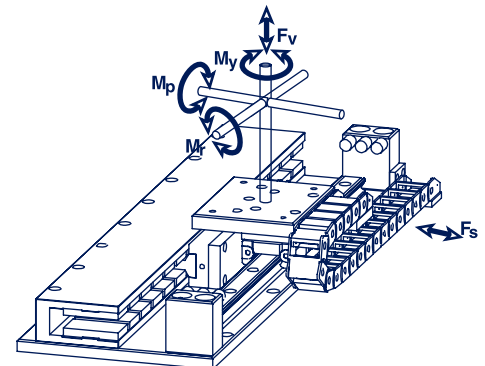

PERFORMANCE	LINEAR MAGNETIC ENCODER		RENISHAW ENCODER OPTIONS (Note 5)		
	5.0µm	1.0.1µm	0.5µm	0.1µm	
Peak Velocity	in/s [m/s]	275 [7]	100 [2.5]	120 [3]	15 [0.4]
Resolution	in [µm]	0.0002 [5]	0.000 04 [1.0]	0.000 02 [0.5]	0.000 004 [0.1]
Repeatability	in [µm]	±0.0004 [±10]	±0.000 8 [2.0]	±0.000 06 [1.5]	±0.000 04 [1.0]
Accuracy – LME	±(30µm +50µm/m)		±(25µm +50µm/m)		
Accuracy – Renishaw					±(5µm +30µm/m)

*Note: For travels less than 1 meter, accuracy should be calculated at 1 meter*

MOTOR MODEL		410-2	410-3	410-4	410-6	410-8
Peak Force	N	1041.4	1523.6	2006.3	2967.2	3928.1
	lb	234.1	342.5	451.0	667.0	883.0
Continuous Force	N	233.1	340.8	448.9	663.7	878.6
	lb	52.4	76.6	100.9	149.2	197.5
Peak Power	W	2835	4050	5265	7695	10125
Continuous Power	W	142	203	263	385	506

ACCURACY	STANDARD	LASER ALIGNMENT OPTION
Straightness restrained on flat surface in [µm]	±0.000127 in/in [±127µm/m]	±.000013 in/in [±13µm/m]
Flatness restrained on flat surface in [µm]	±.003 + .000254 in/in [±76 + 254µm/m]	

*Note: For travels less than 1 meter, Flatness should be calculated at 1 meter*  
*Straightness/Flatness specifications based on system mounted to surface of flatness ±0.0005in/ft*

PHYSICAL		- 2	- 3	- 4	- 6	- 8
Carriage Assembly						
T4DB Aluminum	lbs [kg]	9.0 [4,1]	14.9 [6,8]	18.1 [8,2]	24.1 [10,9]	30.2 [13,7]
T4DS Steel	lbs [kg]	13.29 [6,0]	22.20 [10,1]	28.46 [12,9]	40.51 [18,4]	52.59 [23,9]
Base Assembly						
T4DB Aluminum	lbs/ft [kg/m]	29.4 [43,8]	.....▶	.....▶	.....▶	.....▶
T4DS Steel	lbs/ft [kg/m]	39.3 [58,5]	.....▶	.....▶	.....▶	.....▶
Carriage Length	in [mm]	4.80 [121,9]	8.15 [207,0]	11.50 [292,1]	18.20 [462,3]	24.90 [632,5]
Coil Bar Length	in [mm]	10.00 [254]	13.36 [339]	16.72 [424]	23.44 [595]	30.16 [766]

LOAD		- 2	- 3	- 4	- 6	- 8
Vertical (Fv) see note 11	lbs [kg]	200 [90]	250 [113]	300 [136]	400 [181]	400 [181]
Side (Fs) see note 11	lbs [kg]	150 [68]	150 [68]	150 [68]	150 [68]	150 [68]
Moments–Roll (Mr) see note 11	lb-ft [N-m]	100 [133]	150 [200]	150 [200]	150 [200]	150 [200]
Moments–Pitch (Mp) see note 11	lb-ft [N-m]	200 [266]	400 [532]	400 [532]	400 [532]	400 [532]
Moments–Yaw (My) see note 11	lb-ft [N-m]	200 [266]	400 [532]	400 [532]	400 [532]	400 [532]

### NOTES

- Total travel = OAL – 5.50" (139.7 mm) – carriage length.
- Maximum base length is 120" (3048)
- Aluminum base is black anodized. Steel base is nickel plated.
- For complete motor specifications, refer to 410 series motor data sheet.
- Renishaw encoder, RGH24 series, available in 0.05.0µm, 0.1µm, 0.5µm, 1.0µm, 5.0µm.
- Cable extends past base by approximately 0.6" when carriage is at negative hard stop.
- Cable Track extends 0.175" higher than carriage mounting surface. It is recommended to use optional Spacer Plate for custom mounting holes.
- Standard cable track provided is Igus 07.30.028.
- Base mounting holes are equidistant, 1.680" (16.80, 23.52....) or 3.360" (20.16, 26.88....) from each end depending on base length.
- Specification subject to change without notice.
- Listed specifications based on motor size and typical performance requirements. Bearing manufacturer specifications exceed listed specifications.





Dimensions shown in inches.

● Moving Carriage Assembly

● Stationary Base Assembly

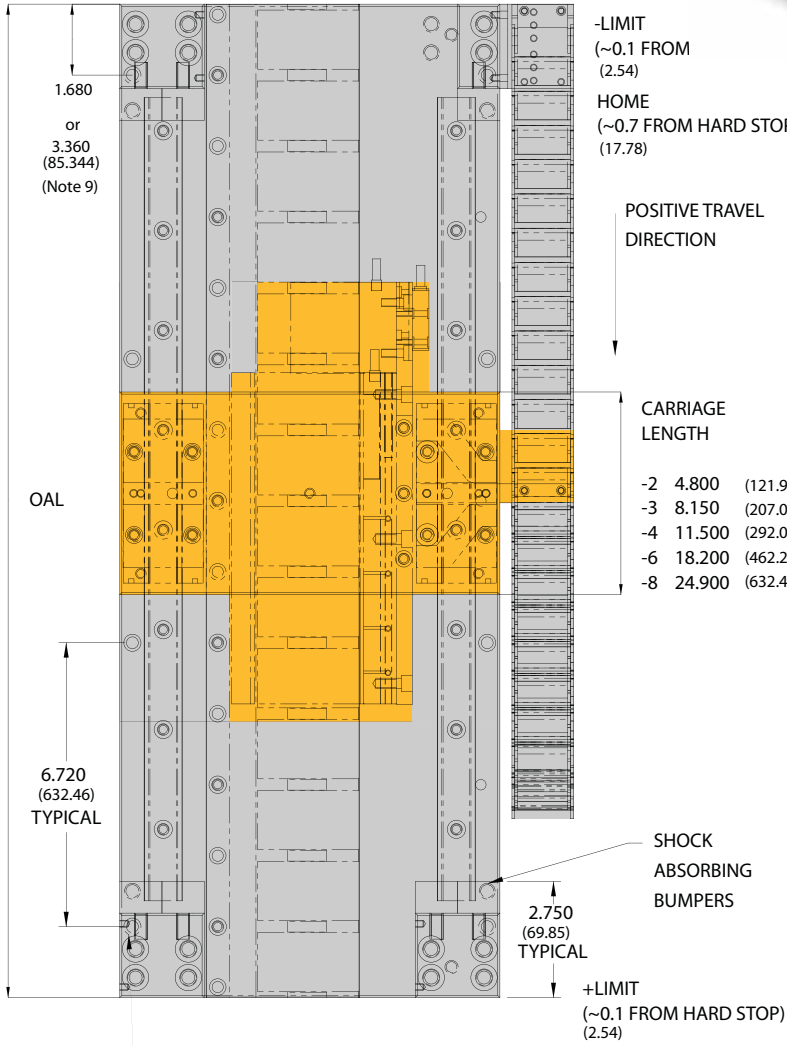
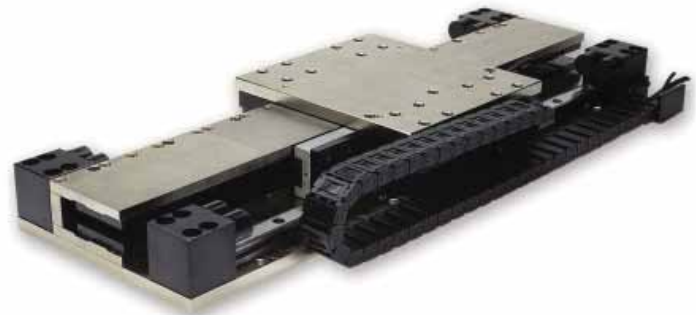

0.375 THICK CARRIAGE SPACER PLATE (optional)  
(9.525)

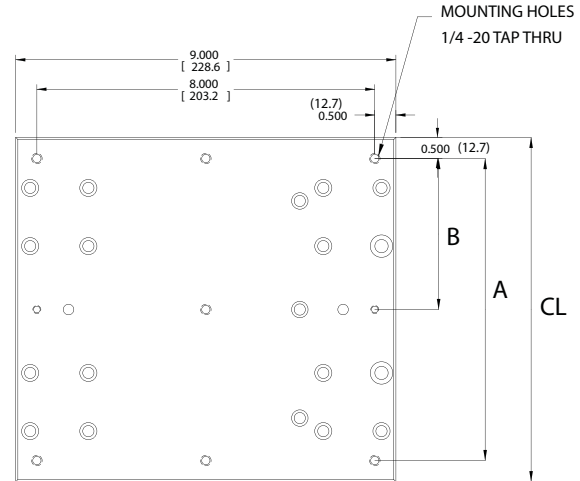
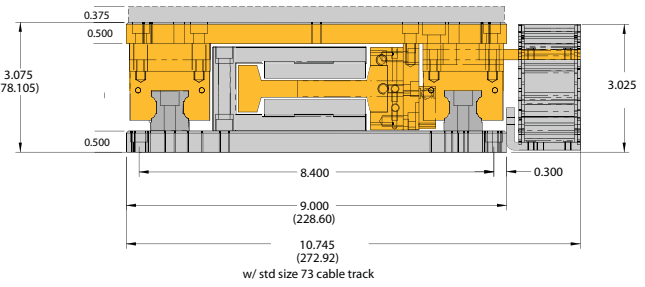

TOTAL TRAVEL = OAL - 5.50" (139.7) - CARRIAGE LENGTH  
OAL = MULTIPLE OF 3.360" (85.34)

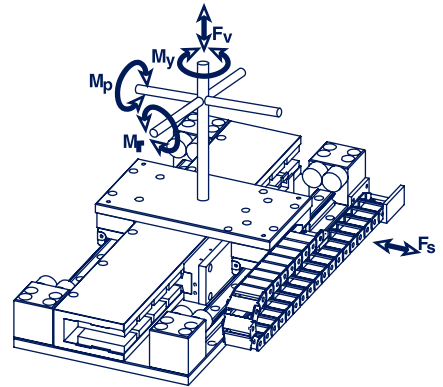

	CARRIAGE SIZE									
	-2	mm	-3	mm	-4	mm	-6	mm	-8	mm
CL	4.800	121.92	8.150	207.01	11.500	292.10	18.200	462.28	24.900	632.46
A	3.800	96.52	7.150	181.61	10.500	266.70	17.200	436.88	23.900	607.66
B	—	—	3.575	90.805	5.250	133.35	8.600	218.44	11.950	303.53
COIL	410-2		410-3		410-4		410-6		410-8	

PERFORMANCE		LINEAR MAGNETIC ENCODER		RENISHAW ENCODER OPTIONS (Note 5)	
		5.0µm	1.0µm	0.5µm	0.1µm
Peak Velocity	in/s [m/s]	275 [7]	100 [2.5]	120 [3]	15 [0.4]
Resolution	in [µm]	0.0002 [5]	0.000 04 [1.0]	0.000 02 [0.5]	0.000 004 [0.1]
Repeatability	in [µm]	±0.0004 [±10]	±0.000 8 [2.0]	±0.000 06 [1.5]	±0.000 04 [1.0]
Accuracy – LME		±(30µm +50µm/m)		±(25µm +50µm/m)	
Accuracy – Renishaw		±(5µm +30µm/m)			

Note: For travels less than 1 meter, accuracy should be calculated at 1 meter

MOTOR MODEL		410-2	410-3	410-4	410-6	410-8
Peak Force	N	1041.4	1523.6	2006.3	2967.2	3928.1
	lb	234.1	342.5	451.0	667.0	883.0
Continuous Force	N	233.1	340.8	448.9	663.7	878.6
	lb	52.4	76.6	100.9	149.2	197.5
Peak Power	W	2835	4050	5265	7695	10125
Continuous Power	W	142	203	263	385	506

ACCURACY		STANDARD	LASER ALIGNMENT OPTION
Straightness restrained on flat surface in [µm]		±0.000125in/in [±127µm/m]	±0.000013 in/in [±13µm/m]
Flatness restrained on flat surface in [µm]		±0.003 + .000254 in/in [±76 + 254µm/m]	

Note: For travels less than 1 meter, Flatness should be calculated at 1 meter

Straightness/Flatness specifications based on system mounted to surface of flatness ±0.0005in/ft

PHYSICAL		- 2	- 3	- 4	- 6	- 8
Carriage Assembly						
T4SB Aluminum	lbs [kg]	6.5 [3,0]	10.3 [4,7]	13.0 [5,9]	17.8 [8,1]	22.7 [10,3]
T4SS Steel	lbs [kg]	8.78 [4,0]	14.22 [6,5]	18.47 [8,4]	26.49 [12,0]	34.54 [15,7]
Base Assembly						
T4SB Aluminum	lbs/ft [kg/m]	26.7 [39,8]	.....▶	.....▶	.....▶	.....▶
T4SS Steel	lbs/ft [kg/m]	34.9 [52,0]	.....▶	.....▶	.....▶	.....▶
Carriage Length	in [mm]	4.80 [121,9]	8.15 [207,0]	11.50 [292,1]	18.20 [462,3]	24.90 [632,5]
Coil Bar Length	in [mm]	10.00 [254]	13.36 [339]	16.72 [424]	23.44 [595]	30.16 [766]

LOAD		- 2	- 3	- 4	- 6	- 8
Vertical (Fv) see note 11	lbs [kg]	150 [68]	175 [79]	175 [79]	200 [90]	200 [90]
Side (Fs) see note 11	lbs [kg]	75 [34]	75 [34]	75 [34]	75 [34]	75 [34]
Moments–Roll (Mr) see note 11	lb-ft [N-m]	50 [66]	100 [133]	100 [133]	100 [133]	100 [133]
Moments–Pitch (Mp) see note 11	lb-ft [N-m]	100 [133]	200 [266]	200 [266]	200 [266]	200 [266]
Moments–Yaw (My) see note 11	lb-ft [N-m]	100 [133]	200 [266]	200 [266]	200 [266]	200 [266]

### NOTES

- Total travel = OAL – 5.50" (139.7 mm) – carriage length.
- Maximum base length is 168", 4.2 meters.
- Aluminum base is black anodized. Steel base is nickel plated.
- For complete motor specifications, refer to 410 series motor data sheet.
- Renishaw encoder, RGH24 series, available in 0.05µm, 0.1µm, 0.5µm, 1.0µm, 5.0µm.
- Cable extends past base by approximately 0.6" when carriage is at negative hard stop.
- Cable Track extends 0.175" higher than carriage mounting surface. It is recommended to use optional Spacer Plate for custom mounting holes.
- Standard cable track provided is Igus 07.30.028.
- Base mounting holes are equidistant, 1.680" (16.80, 23.52....) or 3.360" (20.16, 26.88....) from each end depending on base length.
- Specification subject to change without notice.
- Listed specifications based on motor size and typical performance require Bearing manufacturer specifications exceed listed specifications.



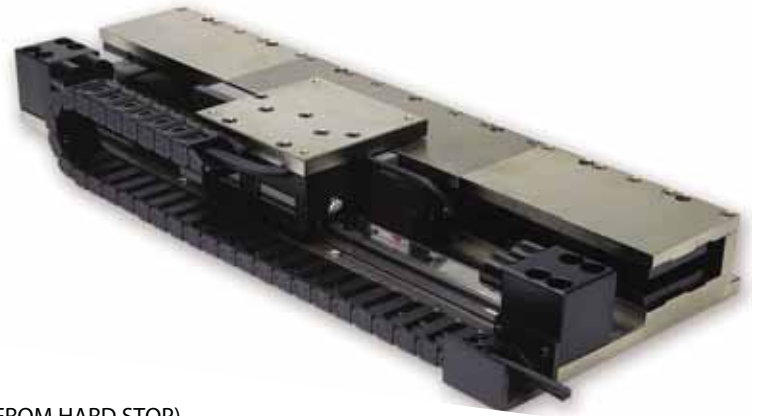

Dimensions shown in inches.

- Moving Carriage Assembly
- Stationary Base Assembly

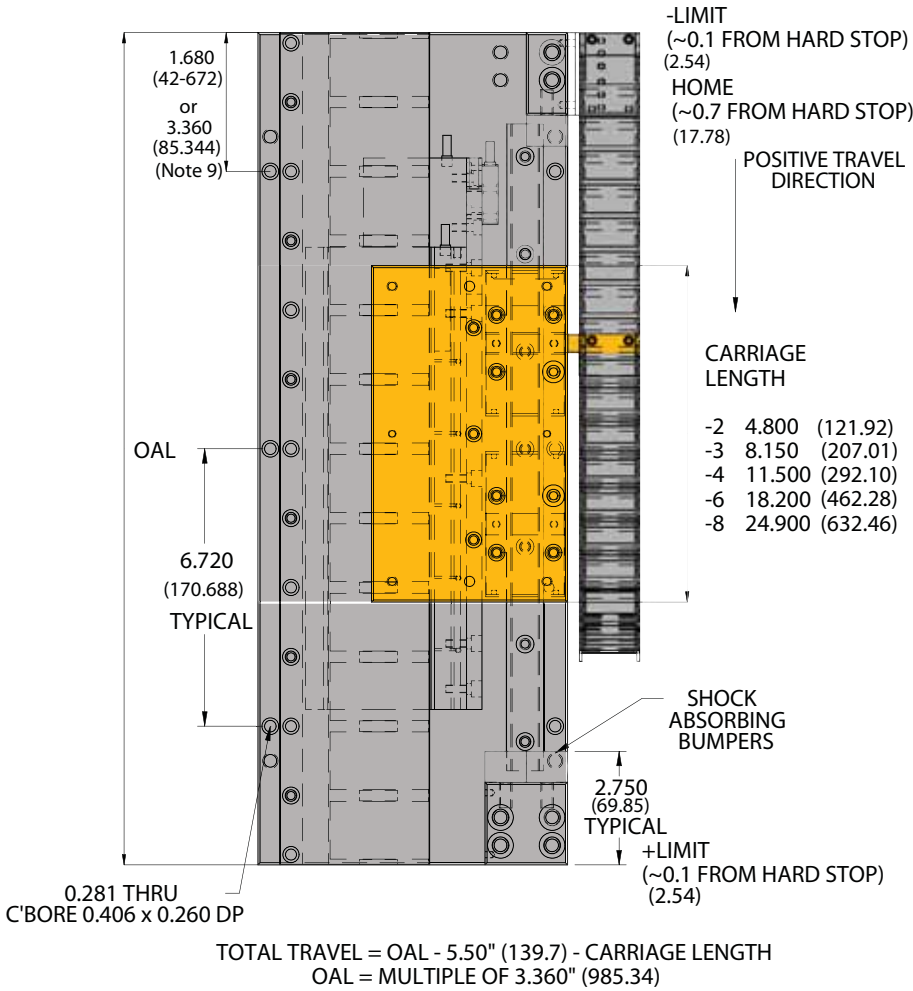

0.375 THICK CARRIAGE SPACER PLATE (optional)  
9.525

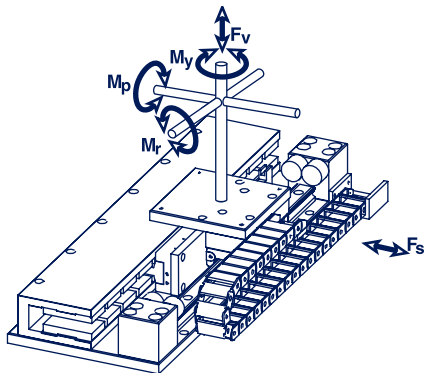
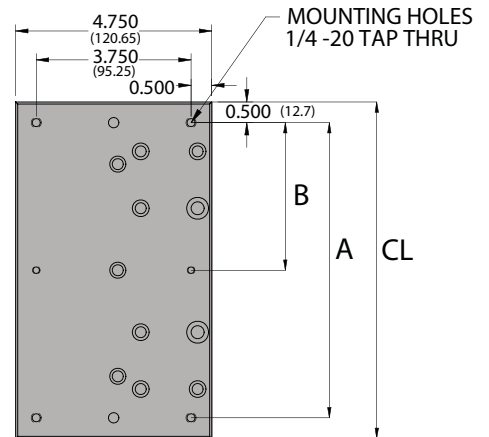
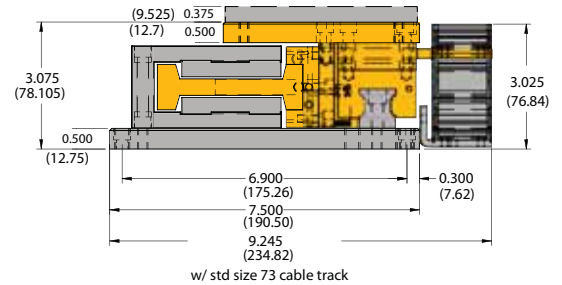

CARRIAGE SIZE										
	-2	mm	-3	mm	-4	mm	-6	mm	-8	mm
CL	4.800	121.92	8.150	207.01	11.500	292.10	18.200	462.28	24.900	632.46
A	3.800	96.52	7.150	181.61	10.500	266.70	17.200	436.88	23.900	607.66
B	—	—	3.575	90.805	5.250	133.35	8.600	218.44	11.950	303.53
COIL	410-2		410-3		410-4		410-6		410-8	

Order Example:

**T 1 D A 012 3 N S B A G 2**

**Series**  
T = Open Positioner

**Motor Coil Series**  
1 = 110 Motor Coil

**Bearing Rail Configuration**  
D = Dual Bearing Rails  
S = Single Bearing Rails

**Base Material**  
A = 3/8" Al

**Length of Base**  
XXX = Length of base in inches  
Max.: 33.6"  
Min.: 9.6"  
Increment: 2.4"

\* Truncate base length in part number. Example: for a 16.8 inch base, "XXX" equal "016"

T1S Base Length = Travel (increments of 2.4" [60.96mm]) + 1.6" [40.64] + carriage length

T1D Base Length = Travel (increments of 2.4" [60.96 mm]) - 0.05" [1027 mm] + carriage length

**Coil Size**  
1 = 1 pole, T1S 3.4" (86.4 mm)  
2 = 2 pole T1S 5.8" (147.3 mm)  
T1D 5.4" (137.6 mm)  
T1D 7.8" (198.12 mm)  
T1S 3.4" (86.4 mm)

**Cooling**  
N no cooling

**Winding Type**  
S Series  
P Parallel

**Cable track**

0 = None  
2 = Std.

**Connector**

Cable Connectorization  
A = Aries  
B = Flying Leads  
C = Compax3  
G = Gemini  
V = ViX  
Z = no cables

\*Connectorized cables only available with Connector Box

**Cable length**

Cable Length  
A = 1 Meter Flying Leads  
B = 3 Meter Flying Leads  
C = 7.5 Meter Flying Leads  
L = 3 Extension Cables (with Connector Box)  
M = 7.5 Extension Cables (with Connector Box)  
Z = Connector Box ONLY (no extension cables)

\*Flying leads – cable measured from last cable carrier link

\*Extension Cables – cable measured from connection box at end of base

**Encoder**

A = LME, 1um  
B = LME, 5um  
Q = Renishaw, 5um  
L = Renishaw, 1um  
M = Renishaw, 0.5m  
P = Renishaw, 0.1um  
R = Renishaw, 1 V p-p sine/cosine  
X = No encoder

Order Example:

T 2 D A 012 3 N S B A B 3

**Series**  
 T = Open Positioner  
 B = Bellows Positioner

**Motor Coil Series**  
 2 = 210 motor coil

**Bearing Rail Configuration**  
 D = Dual Bearing Rails  
 S = Single Bearing Rails  
 \* Bellows positioners not available in single rail

**Base material**  
 A = 0.375" Al

**Length of Base**  
 XXX = Length of base in inches  
 Max.: 120\*  
 Min.: 9.6"  
 Increment: 2.4"  
 \* Truncate base length in part number. Example: for a 16.8 inch base, "XXX" equal "016"  
 T1S Base Length = Travel (increments of 2.4" [60.96 mm]) + 3.0" [76.2] + carriage length  
 T1D Base Length = Travel Travel (increments of 2.4" [60.96 mm])

**Coil size**  
 2 = 2 pole, 4.2 in (106.68 mm)  
 3 = 3 pole, 6.6 in (106.64 mm)  
 4 = 4 pole, 9.0 in (228.60 mm)

**Cooling**  
 N no cooling

**Winding Type**  
 S Series  
 P Parallel

**Cable track**  
 0 = (no track)  
 3 = (standard)

**Connector**  
 Cable Connectorization  
 A = Aries  
 B = Flying Leads  
 C = Compax3  
 G = Gemini  
 V = ViX  
 Z = no cables  
 \*Connectorized cables only available with Connector Box

**Cable length**  
 A = 1 Meter Flying Leads  
 B = 3 Meter Flying Leads  
 C = 7.5 Meter Flying Leads  
 L = 3 Extension Cables (with Connector Box)  
 M = 7.5 Extension Cables (with Connector Box)  
 Z = Connector Box ONLY (no extension cables)  
 \*Flying leads – cable measured from last cable carrier link  
 \*Extension Cables – cable measured from connection box at end of base  
 \*7.5 Meter Flying Lead Cables available on:  
 All bases with LME encoder  
 All bases with Renishaw encoder under 86"  
 For bases with Renishaw encoder over 86" the cable length (CL) will be CL = 10M - (base length in meters + 0.3M)

**Encoder**  
 A = LME 1 um  
 B = LME 5 um  
 Q = Renishaw 5 um  
 L = Renishaw 1 um  
 M = Renishaw 0.5 um  
 P = Renishaw 0.1 um  
 R = Renishaw IV p-p sine/cosine  
 X = No Encoder

\*Consult factory for longer lengths.



Order Example:

**T 3 D B 012 3 N S B A C 3**

**Series**  
**T** = Open Positioner  
**B** = Bellows Positioner

**Motor Coil Series**  
**3** = 310 Motor Coil

**Bearing Rail Configuration**  
**D** = Dual Bearing Rails  
**S** = Single Bearing Rails  
 \* Bellows positioners not available in single rail

**Base Material**  
**B** = 1/2" Al

**Length of Base**  
**XXX** = Length of base in inches  
 Max.: 118"  
 Min.: 9.6"  
 Increment: 2.4"  
 \* Truncate base length in part number. Example: for a 16.8 inch base, "XXX" equal "016"  
 Base Length = Travel (increments of 2.4" [60.96mm]) + 3.0" [76.2 mm] + carriage length

**Coil Size**  
**2** = 2 pole T3S 5.0" [127 mm], T3D 4.2" [106.68]  
**3** = 3 pole 6.6" [167.64 mm]  
**4** = 4 pole 9.0" [228.60 mm]  
**5** = 5 pole 11.4" [289.56 mm]  
**6** = 6 pole 13.3" [350.62 mm]

**Cooling**  
**N** no cooling

**Winding Type**  
**S** Series  
**P** Parallel

**Cable track**  
**0** = None  
**3** = Std.

**Connector**  
 Cable Connectorization  
**A** = Aries  
**B** = Flying Leads  
**C** = Compax3  
**G** = Gemini  
**V** = ViX  
**Z** = no cables  
 \*Connectorized cables only available with Connector Box

**Cable length**  
 Cable Length  
**A** = 1 Meter Flying Leads  
**B** = 3 Meter Flying Leads  
**C** = 7.5 Meter Flying Leads  
**L** = 3 Extension Cables (with Connector Box)  
**M** = 7.5 Extension Cables (with Connector Box)  
**Z** = Connector Box ONLY (no extension cables)

**Encoder**  
**A** = LME, 1um  
**B** = LME, 5um  
**Q** = Renishaw, 5um  
**L** = Renishaw, 1um  
**M** = Renishaw, 0.5m  
**P** = Renishaw, 0.1um  
**R** = Renishaw, 1 V p-p sine/cosine  
**X** = No encoder

\*Flying leads – cable measured from last cable carrier link  
 \*Extension Cables – cable measured from connection box at end of base  
 \*7.5 Meter Flying Lead Cables available on:  
 All bases with LME encoder  
 All bases with Renishaw encoder under 86"  
 For bases with Renishaw encoder over 86" the cable length (CL) will be CL = 10M - (base length in meters + 0.3M)

Order Example:

T 4 D B XXX 3 N S B A B 4

**Series**  
 T = Open Positioner  
 B = Bellows Positioner

**Motor Coil Series**  
 4 = 410 motor coil

**Bearing Rail Configuration**  
 D = Dual Bearing Rails  
 S = Single Bearing Rails  
 \* Bellows positioners not available in single rail

**Base material**  
 B = 1/2" Al

**Length of Base**  
 XXX = Length of base in inches  
 Max.: 120" \*  
 Min.: 13.44"  
 Increment: 3.36"  
 \* Truncate base length in part number.  
 Example: for a 16.8 inch base, "XXX" equal "016"  
 Base Length = Travel (increments of 2.4" [60.96mm]) + 5.5" [39.7 mm] + carriage length

**Coil size**  
 2 = 2 pole 4.8" [121.92 mm]  
 3 = 3 pole 8.15" [207.01 mm]  
 4 = 4 pole 11.5" [292.10 mm]  
 6 = 6 pole 18.2" [462.28 mm]  
 8 = 8 pole 24.9" [632.46 mm]

**Cooling**  
 N no cooling

**Winding Type**  
 S Series  
 P Parallel

**Cable track**  
 0 = (no track)  
 4 = (standard)

**Connector**  
 Cable Connectorization  
 A = Aries  
 B = Flying Leads  
 C = Compax3  
 G = Gemini  
 V = ViX  
 Z = no cables  
 \*Connectorize cables only available with Connector Box

**Cable length**  
 A = 1 Meter Flying Leads  
 B = 3 Meter Flying Leads  
 C = 7.5 Meter Flying Leads  
 L = 3 Extension Cables (with Connector Box)  
 M = 7.5 Extension Cables (with Connector Box)  
 Z = Connector Box ONLY (no extension cables)  
 \*Flying leads – cable measured from last cable carrier link  
 \*Extension Cables – cable measured from connection box at end of base  
 \*7.5 Meter Flying Lead Cables available on:  
 All bases with LME encoder  
 All bases with Renishaw encoder under 86"  
 For bases with Renishaw encoder over 86" the cable length (CL) will be  
 CL = 10M - (base length in meters + 0.3M)

**Encoder**  
 A = LME 1 um  
 B = LME 5 um  
 Q = Renishaw 5 um  
 L = Renishaw 1 um  
 M = Renishaw 0.5 um  
 P = Renishaw 0.1 um  
 R = Renishaw IV p-p sine/cosine  
 X = No Encoder

\*Consult factory for longer lengths.



# RIPPED Ironcore Linear Positioners

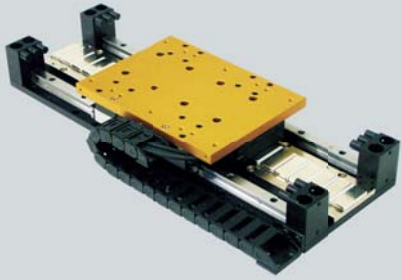

Parker Trilogi's RIPPED linear positioners utilize our high-performance RIPPED ironcore linear motors in a pre-engineered, easily integrated, ready-to-run package. These positioners are engineered to achieve high performance at an economical cost while preserving design flexibility to accommodate customization. Combined with RIPPED ironcore motors – with their patent-pending anti-cog technology, these linear motor tables produce extremely smooth motion and can be used in many applications where ironless motors traditionally were needed.

Trilogi's positioners utilize high-precision square rail bearings. In addition, they are designed to connect together using transition plates for XY or multi-axis configurations. Options include a variety of cable management systems in addition to bellows and hard covers.

High force capability, multi-axis compatibility, and ease of customization make the RIPPED ironcore linear positioners an optimal choice for high performance and value.

## Features

- Standard lengths to 3 meters
- Extended lengths as standard options
- Incremental length of 60mm for TR10 and TR16
- Incremental length of 80mm for TR07
- Stainless cover options for TR07, TR10 and TR16
- Maximum cover length of 144"
- Optical or magnetic encoders
- Optical encoders; 1.0um, 0.50um, 0.10um
- Magnetic encoder: 5.0um
- Magnetic Home and End-of-Travel limits



# TR07

open design

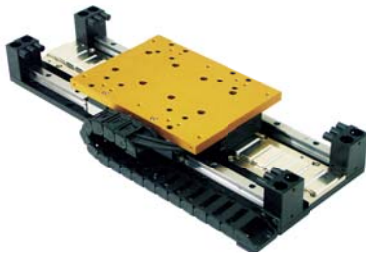

# BR07

bellows design

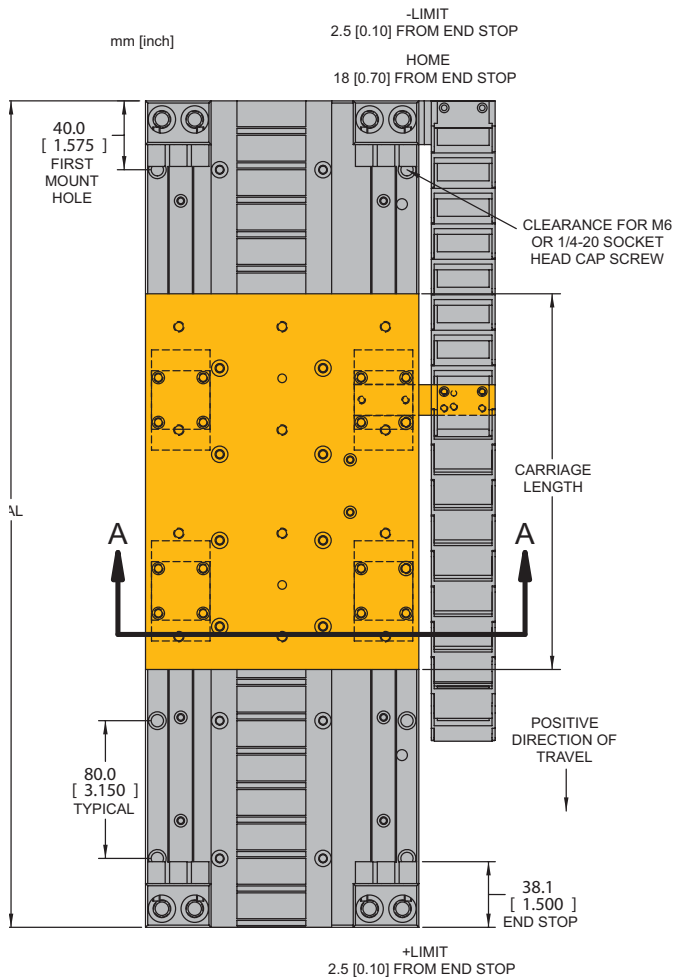

TRAVEL (mm) = OAL - 76.2 - CARRIAGE LENGTH  
OVERALL LENGTH (OAL) = MULTIPLE OF 80 mm UP TO 3040 mm

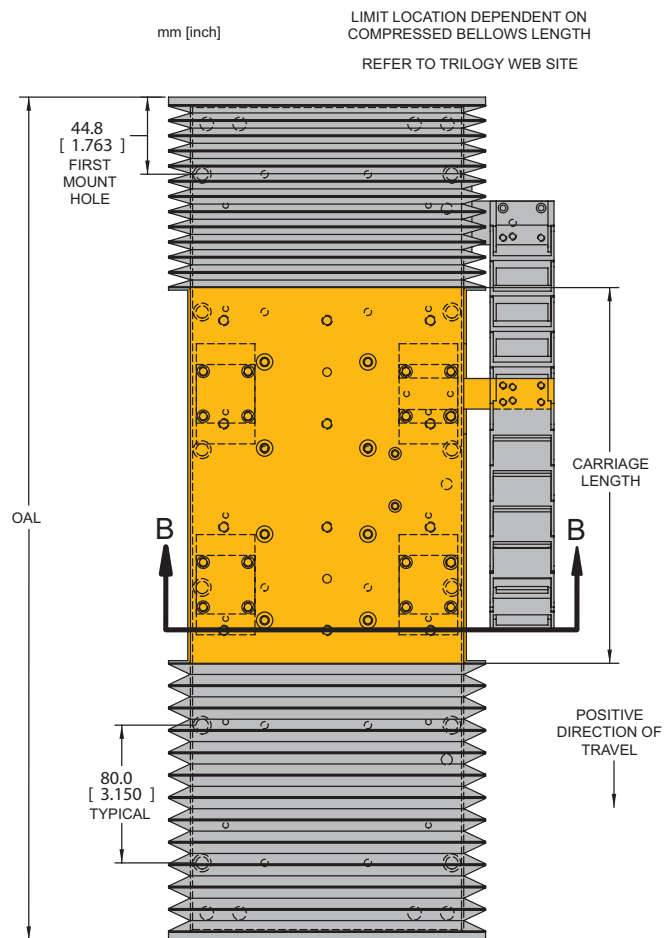

REFER TO TRILOGY WEB SITE FOR TRAVEL  
BASE LENGTH = MULTIPLE OF 80 mm UP TO 3040 mm  
OAL = BASE LENGTH + 9.5 mm

\* IRONCORE MOTOR

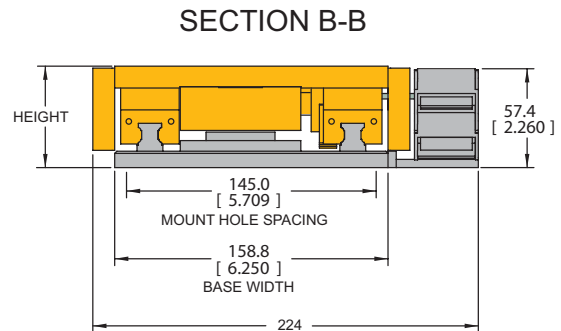
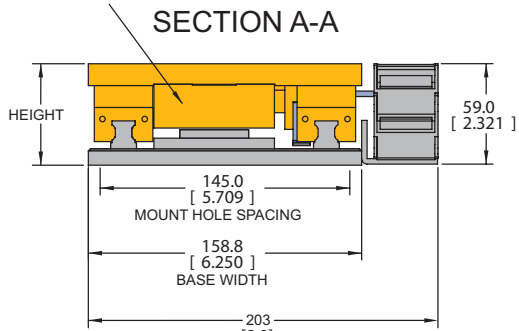

OVERALL WIDTH (OAW)			
IGUS CABLE TRACK	PART NO. DESIGNATOR	TR07 mm [in]	BR07 mm [in]
07-20-18	Custom	193 [7.6]	214 [8.4]
07-30-18	3	203 [8.0]	224 [8.8]
07-40-18	Custom	213 [8.4]	234 [9.2]
07-50-18	Custom	223 [8.8]	244 [9.6]
07-64-18	Custom	237 [9.3]	258 [10.2]

CARRIAGE LENGTH			
COIL SIZE	-1	-2	-3
TR07/BR07 CARRIAGE	218.2 [8.591]	378.2 [14.890]	538.2 [21.189]
A (1st MOUNT HOLE)	19.1 [0.752]	9.1 [0.358]	29.1 [1.146]
NUMBER OF MOUNTING HOLES	12	21	27
B (DOWEL PIN HOLE)	49.1 [1.933]	99.1 [3.901]	119.1 [4.689]

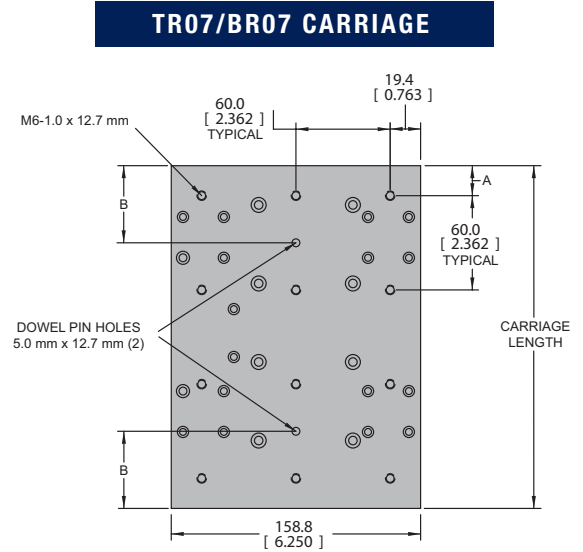

## Smooth operation with Anti-Cogging features –

Parker Trilogy's RIPPED Series Ironcore Positioners utilize Parker's patent pending Anti-Cogging techniques for superior smoothness. Traditional ironcore motors exhibit cogging forces when the internal iron laminations exhibit a horizontal force on the motor when trying to line up with their "preferred" positions over the magnets. Cogging limits the overall smoothness of the motion system.

Parker Trilogy has developed an Anti-Cogging technological breakthrough that virtually eliminates cogging and allows ironcore motors to be used in applications where only ironless motors were used before. This offers the user a powerful combination of extremely high force and smooth operation in an economical package.

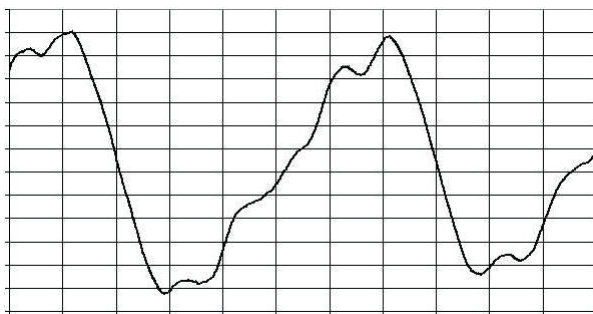

Typical Ironcore Positioner Cogging Forces

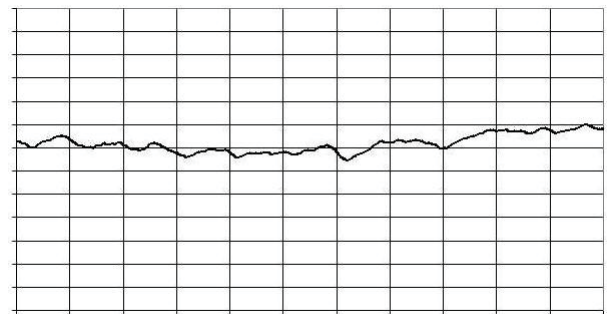

Cogging forces with Parker Trilogy's patent-pending Anti-Cog Technology



## PERFORMANCE

ENCODER	LINEAR MAGNETIC ENCODER			RENISHAW OPTICAL ENCODER		
	1.0 $\mu\text{m}$	5.0 $\mu\text{m}$	0.5 $\mu\text{m}$	1.0 $\mu\text{m}$	5.0 $\mu\text{m}$	
Part Number Designator	A	B	M	L	Q	
Encoder Model	LME1	LME5	RGH24Z	RGH24X	RGH24D	
Peak Velocity	m/s [in/s]	2.5 [100]	7 [275]	3 [120]	5 [200]	
Resolution	$\mu\text{m}$ [in]	1.0 [0.00004]	5.0 [0.0002]	0.5 [0.00002]	1.0 [0.00004]	
Repeatability	$\mu\text{m}$ [in]	$\pm 2.0$ [ $\pm 0.00008$ ]	$\pm 10.0$ [ $\pm 0.0004$ ]	$\pm 1.5$ [ $\pm 0.00006$ ]	$\pm 2.0$ [ $\pm 0.00008$ ]	
Accuracy - LME		$\pm(25 \mu\text{m} + 50 \mu\text{m}/\text{m})$	$\pm(30 \mu\text{m} + 50 \mu\text{m}/\text{m})$			
Accuracy - Renishaw				$\pm(5 \mu\text{m} + 30 \mu\text{m}/\text{m})$	$\pm(10 \mu\text{m} + 30 \mu\text{m}/\text{m})$	

Note: For travels less than 1 meter, accuracy should be calculated at 1 meter

MOTOR MODEL		R07-1	R07-2	R07-3
Peak Force	N	587	1174	1761
	lb	132	264	396
Continuous Force	N	154	308	462
	lb	35	69	104
Peak Power	W	3600	7200	10800
Continuous Power	W	180	360	540

## ACCURACY

Base Length	< 1 meter	> 1 meter
Straightness restrained on a flat surface $\mu\text{m}$ [in]	$\pm 127 \mu\text{m}/\text{m}$ [ $\pm 0.000127$ in/in]	$\pm 127 \mu\text{m}/\text{m}$ [ $\pm 0.000127$ in/in]
Flatness restrained on a flat surface $\mu\text{m}$ [in]	$\pm 330$ [ $\pm 0.013$ ]	$\pm 76 + 254 \mu\text{m}/\text{m}$ [ $\pm 0.003 + .000254$ in/in]

Note: Straightness/Flatness specifications based on system mounted to surface of flatness  $\pm 0.0005$  in/ft

## PHYSICAL

COIL SIZE		-1	-2	-3
Carriage Assembly				
TR07	kg [lb]	3.5 [7.7]	6.3 [13.9]	9.1 [19.9]
BR07	kg [lb]	3.6 [7.9]	6.5 [14.2]	9.3 [20.4]
Base Assembly (0.375" thick aluminum)				
TR07A	kg/mm [lb/in]	0.0128 [0.714]	----->----->	----->
BR07A	kg/mm [lb/in]	0.0131 [0.733]	----->	----->
Base Assembly (0.500" thick aluminum)				
TR07B	kg/mm [lb/in]	0.0141 [0.791]	----->----->	----->
BR07B	kg/mm [lb/in]	0.0145 [0.810]	----->	----->

## LOAD (Recommended)

COIL SIZE		-1	-2	-3
Vertical (Fv) see note 4	kg [lb]	100 [220]	150 [330]	200 [440]
Side (Fs) see note 4	kg [lb]	50 [110]	75 [165]	100 [220]
Moments-Roll (Mr) see note 4	N-m [lb-ft]	50 [37]	75 [55]	100 [74]
Moments-Pitch (Mp) see note 4	N-m [lb-ft]	100 [74]	250 [184]	400 [295]
Moments-Yaw (My) see note 4	N-m [lb-ft]	100 [74]	250 [184]	400 [295]

## NOTES

1. Maximum base length is 3040 mm (limited by maximum single piece bearing rail).
2. Refer to R07 motor data sheet for complete motor specifications.
3. Motor force must be derated by 50% in a "stalled motor" operating condition.
4. Recommended loads based on motor size and typical performance requirements (consult factory if desired loads are greater).
5. Specifications subject to change without notice. Most current brochure available online in PDF format.
6. Refer to website for Ironcore Motor Safe Handling and Cautionary guidelines.

# TR10

open design



# BR10

bellows design

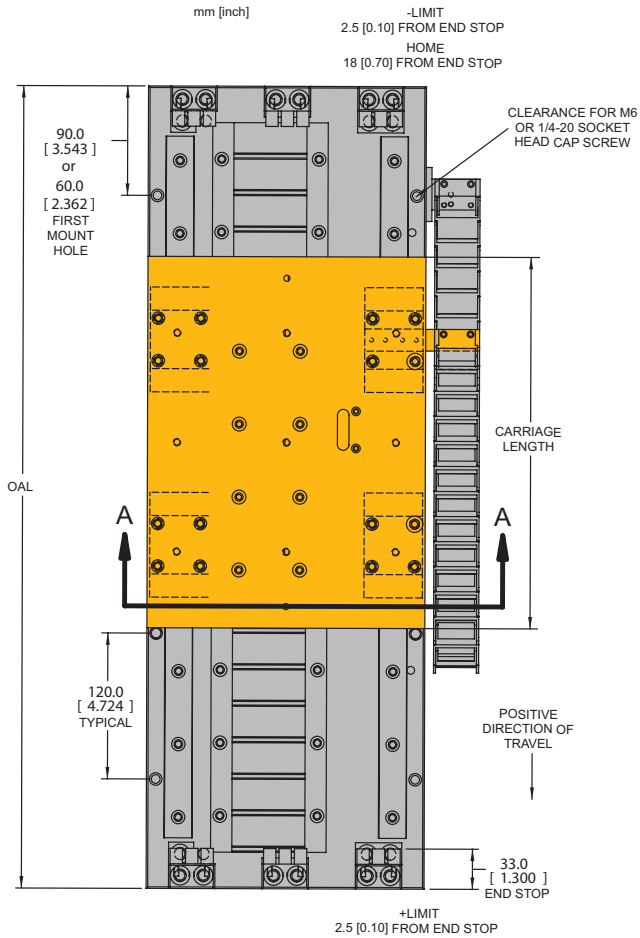
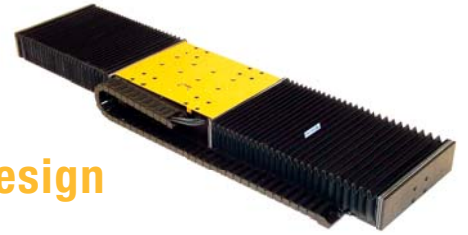

TRAVEL (mm) = OAL - 66.0 - CARRIAGE LENGTH  
OVERALL LENGTH (OAL) = MULTIPLE OF 60 mm UP TO 4080 mm

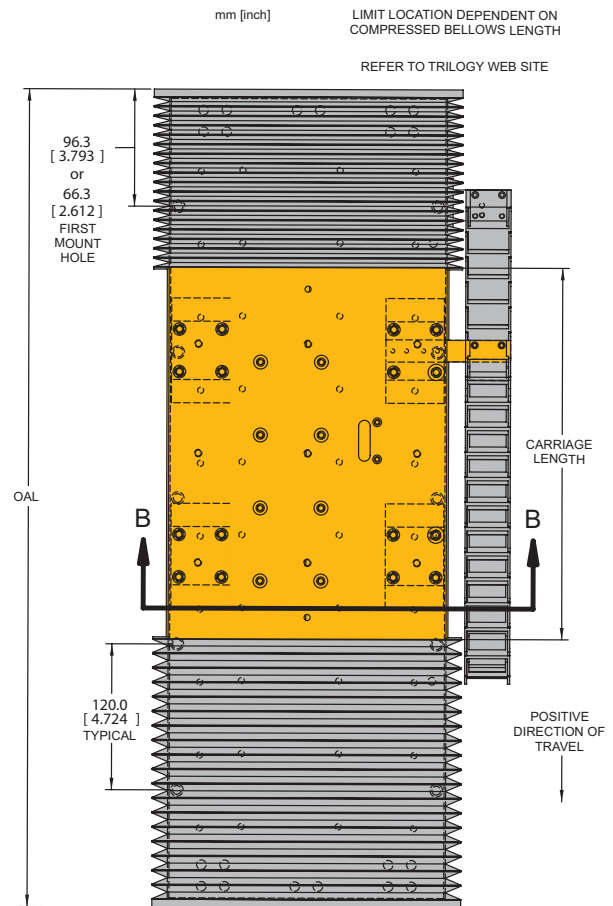

REFER TO TRILOGY WEB SITE FOR TRAVEL  
BASE LENGTH = MULTIPLE OF 60 mm UP TO 4080 mm  
OAL = BASE LENGTH + 12.7 mm

R10 IRONCORE MOTOR

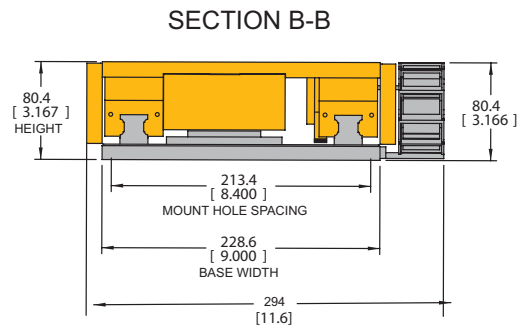
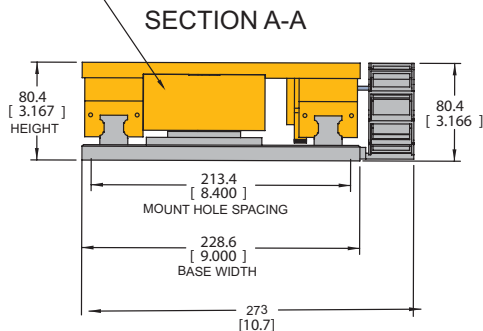



OVERALL WIDTH (OAW)			
IGUS CABLE TRACK	PART NO. DESIGNATOR	TR10 mm [in]	BR10 mm [in]
07-20-18	Custom	263 [10.4]	284 [11.2]
07-30-18	3	273 [10.7]	294 [11.6]
07-40-18	Custom	283 [11.1]	304 [12.0]
07-50-18	Custom	293 [11.5]	314 [12.4]
07-64-18	Custom	307 [12.1]	328 [12.9]

CARRIAGE LENGTH			
COIL SIZE	-1	-2	-3
TR10/BR10 CARRIAGE	305.5 [12.027]	545.5 [21.475]	785.5 [30.924]
A (1st MOUNT HOLE)	62.7 [2.470]	47.7 [1.879]	77.7 [3.060]
NUMBER OF MOUNTING HOLES	9	18	24
B (DOWEL PIN HOLE)	17.7 [0.699]	92.7 [3.651]	212.7 [8.375]

### TR10/BR10 CARRIAGE

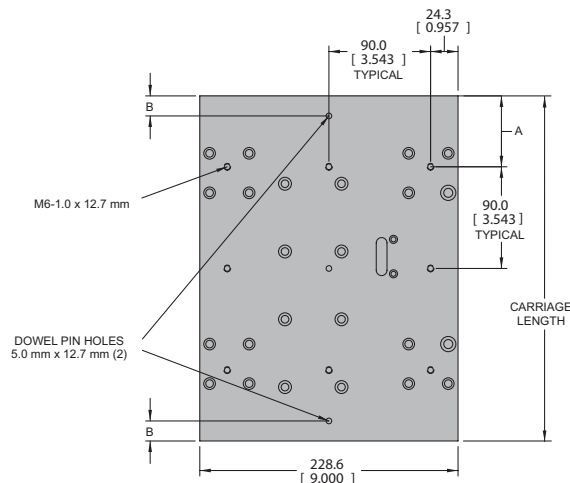

## Smooth operation with Anti-Cogging features –

Parker Trilogi's RIPPED Series Ironcore Positioners utilize Parker's patent pending Anti-Cogging techniques for superior smoothness. Traditional ironcore motors exhibit cogging forces when the internal iron laminations exhibit a horizontal force on the motor when trying to line up with their "preferred" positions over the magnets. Cogging limits the overall smoothness of the motion system.

Parker Trilogi has developed an Anti-Cogging technological breakthrough that virtually eliminates cogging and allows ironcore motors to be used in applications where only ironless motors were used before. This offers the user a powerful combination of extremely high force and smooth operation in an economical package.

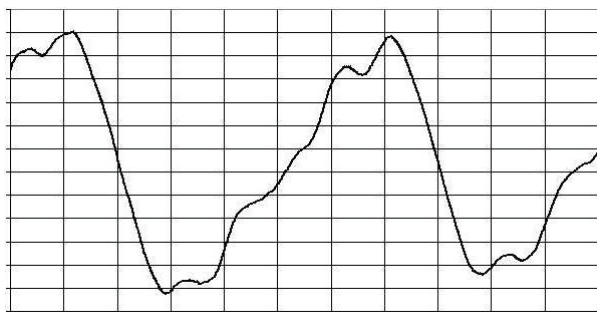

Typical Ironcore Positioner Cogging Forces

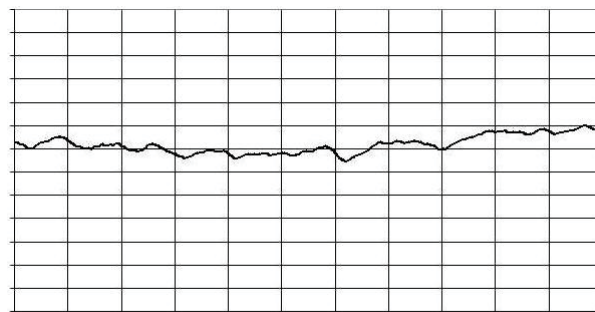

Cogging forces with Parker Trilogi's patent-pending Anti-Cog Technology

### PERFORMANCE

ENCODER	LINEAR MAGNETIC ENCODER			RENISHAW OPTICAL ENCODER	
	1.0 $\mu\text{m}$	5.0 $\mu\text{m}$	0.5 $\mu\text{m}$	1.0 $\mu\text{m}$	5.0 $\mu\text{m}$
Part Number Designator	A	B	M	L	Q
Encoder Model	LME1	LME5	RGH24Z	RGH24X	RGH24D
Peak Velocity	m/s [in/s]	2.5 [100]	7 [275]	3 [120]	5 [200]
Resolution	$\mu\text{m}$ [in]	1.0 [0.00004]	5.0 [0.0002]	0.5 [0.00002]	1.0 [0.00004]
Repeatability	$\mu\text{m}$ [in]	$\pm 2.0$ [ $\pm 0.00008$ ]	$\pm 10.0$ [ $\pm 0.0004$ ]	$\pm 1.5$ [ $\pm 0.00006$ ]	$\pm 2.0$ [ $\pm 0.00008$ ]
Accuracy - LME	$\pm(25 \mu\text{m} + 50 \mu\text{m}/\text{m})$		$\pm(30 \mu\text{m} + 50 \mu\text{m}/\text{m})$		
Accuracy - Renishaw				$\pm(5 \mu\text{m} + 30 \mu\text{m}/\text{m})$	$\pm(10 \mu\text{m} + 30 \mu\text{m}/\text{m})$

Note: For travels less than 1 meter, Accuracy should be calculated at 1 meter

MOTOR MODEL		R10-1	R10-2	R10-3
Peak Force	N	1366	2731	4097
	lb	307	614	921
Continuous Force	N	374	747	1121
	lb	84	168	252
Peak Power	W	6098	12196	18294
Continuous Power	W	305	610	915

### ACCURACY

Base Length	< 1 meter	> 1 meter
Straightness restrained on a flat surface $\mu\text{m}$ [in]	$\pm 127 \mu\text{m}/\text{m}$ [ $\pm 0.000127$ in/in]	$\pm 127 \mu\text{m}/\text{m}$ [ $\pm 0.000127$ in/in]
Flatness restrained on a flat surface $\mu\text{m}$ [in]	$\pm 330$ [ $\pm 0.013$ ]	$\pm 76 + 254 \mu\text{m}/\text{m}$ [ $\pm 0.003 + .000254$ in/in]

Note: Straightness/Flatness specifications based on system mounted to surface of flatness  $\pm 0.0005$  in/ft

### PHYSICAL

COIL SIZE		-1	-2	-3	
Carriage Assembly	TR10	kg [lb]	9.5 [20.9]	17.1 [37.5]	24.6 [54.2]
	BR10	kg [lb]	9.7 [21.3]	17.4 [38.2]	25.1 [55.2]
	Base Assembly (0.500" thick aluminum)				
	TR10B	kg/mm [lb/in]	0.0186 [1.042]	----->----->	
	BR10B	kg/mm [lb/in]	0.0194 [1.084]	----->----->	

### LOAD (Recommended)

COIL SIZE		-1	-2	-3
Vertical (Fv) see note 4	kg [lb]	200 [440]	250 [550]	300 [660]
Side (Fs) see note 4	kg [lb]	100 [220]	125 [275]	150 [330]
Moments-Roll (Mr) see note 4	N-m [lb-ft]	100 [74]	125 [92]	150 [111]
Moments-Pitch (Mp) see note 4	N-m [lb-ft]	200 [148]	400 [295]	600 [443]
Moments-Yaw (My) see note 4	N-m [lb-ft]	200 [148]	400 [295]	600 [443]

### NOTES

- Maximum base length is 3040 mm (limited by maximum single piece bearing rail).
- Refer to R10 motor data sheet for complete motor specifications.
- Motor force must be derated by 50% in a "stalled motor" operating condition.
- Recommended loads based on motor size and typical performance requirements (consult factory if desired loads are greater).
- Specifications subject to change without notice. Most current brochure available online in PDF format.
- Refer to website for Ironcore Motor Safe Handling and Cautionary guidelines.



# TR16

open design

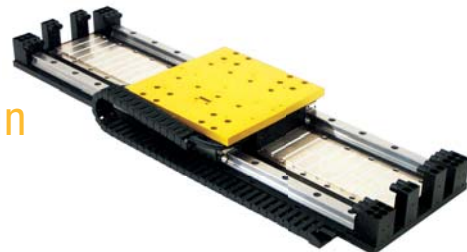

# BR16

bellows design

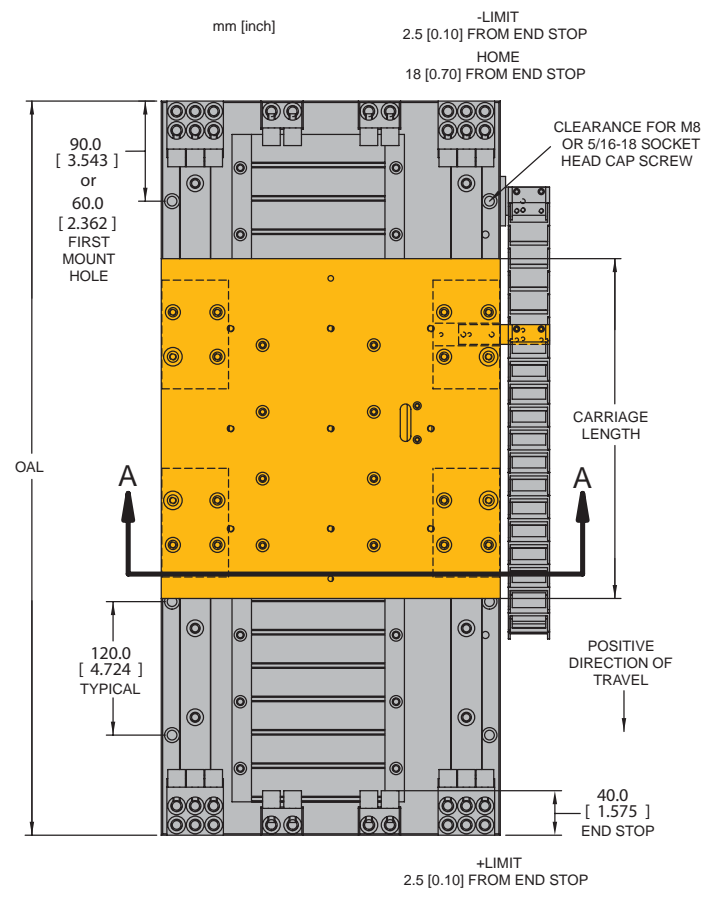

TRAVEL (mm) = OAL - 80.0 - CARRIAGE LENGTH  
OVERALL LENGTH (OAL) = MULTIPLE OF 60 mm UP TO 4080 mm

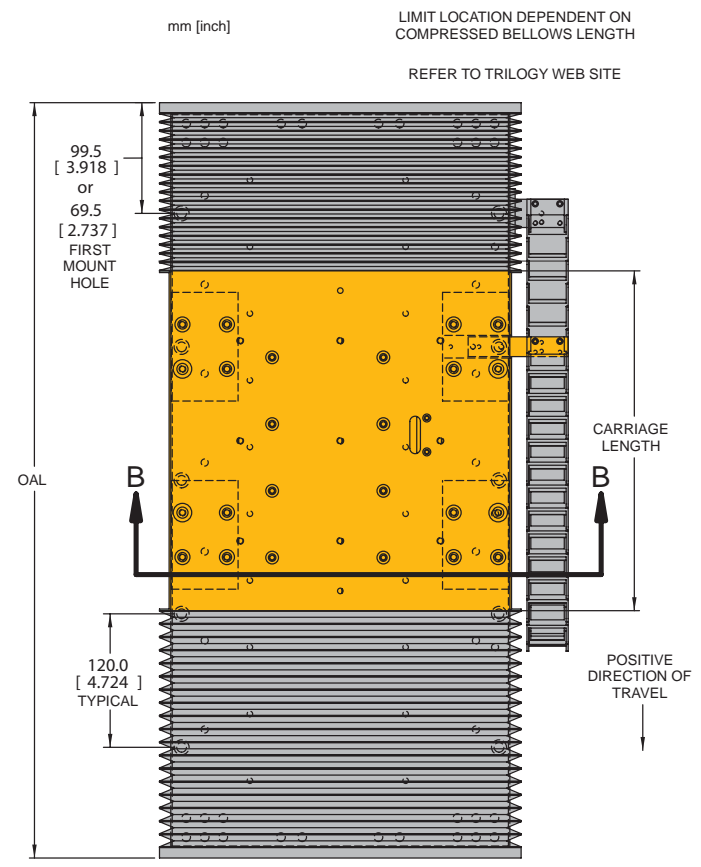

REFER TO TRILOGY WEB SITE FOR TRAVEL  
BASE LENGTH = MULTIPLE OF 60 mm UP TO 4080 mm  
OAL = BASE LENGTH + 19.1 mm

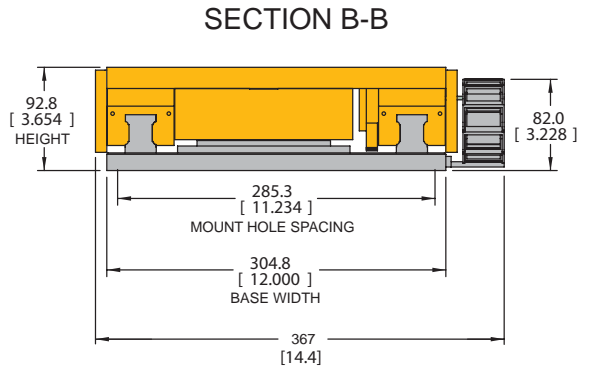
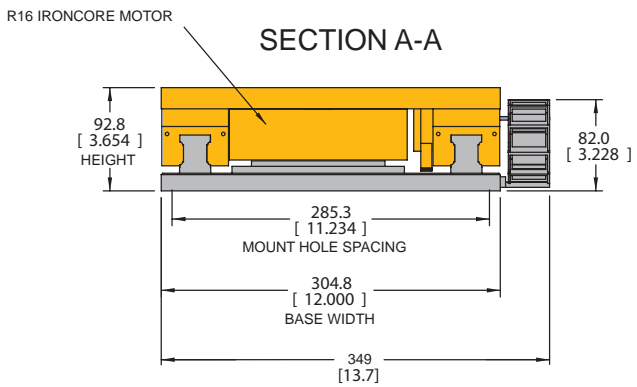

# RIPPED Ironcore Linear Motor Positioners

OVERALL WIDTH (OAW)			
IGUS CABLE TRACK	PART NO. DESIGNATOR	TR16 mm [in]	BR16 mm [in]
07-20-18	Custom	339 [13.3]	357 [14.1]
07-30-18	3	349 [13.7]	367 [14.4]
07-40-18	Custom	359 [14.1]	377 [14.8]
07-50-18	Custom	369 [14.5]	387 [15.2]
07-64-18	Custom	383 [15.1]	401 [15.8]

CARRIAGE LENGTH			
COIL SIZE	-1	-2	-3
TR16/BR16 CARRIAGE	305.5 [12.027]	545.5 [21.475]	785.5 [30.924]
A (1st MOUNT HOLE)	62.7 [2.470]	47.7 [1.879]	77.7 [3.060]
NUMBER OF MOUNTING HOLES	9	18	24
B (DOWEL PIN HOLE)	17.7 [0.698]	92.7 [3.651]	212.7 [8.375]

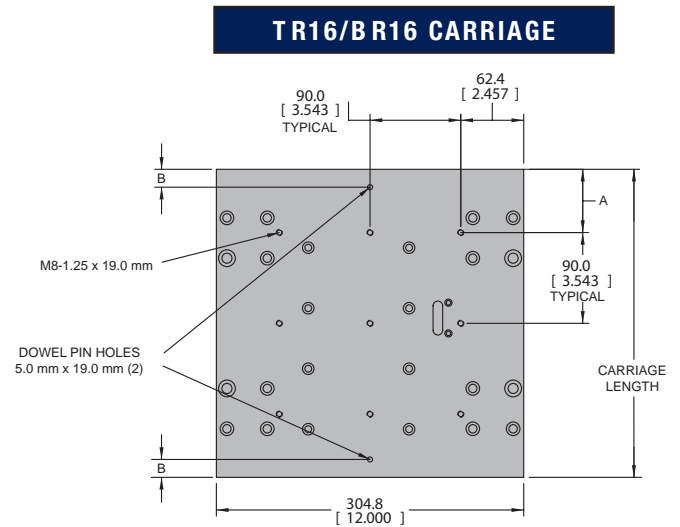

## Smooth operation with Anti-Cogging features –

Parker Trilogy's RIPPED Series Ironcore Positioners utilize Parker's patent pending Anti-Cogging techniques for superior smoothness. Traditional ironcore motors exhibit cogging forces when the internal iron laminations exhibit a horizontal force on the motor when trying to line up with their "preferred" positions over the magnets. Cogging limits the overall smoothness of the motion system.

Parker Trilogy has developed an Anti-Cogging technological breakthrough that virtually eliminates cogging and allows ironcore motors to be used in applications where only ironless motors were used before. This offers the user a powerful combination of extremely high force and smooth operation in an economical package.

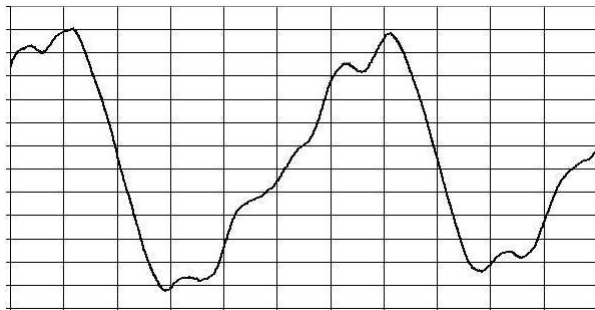

Typical Ironcore Positioner Cogging Forces

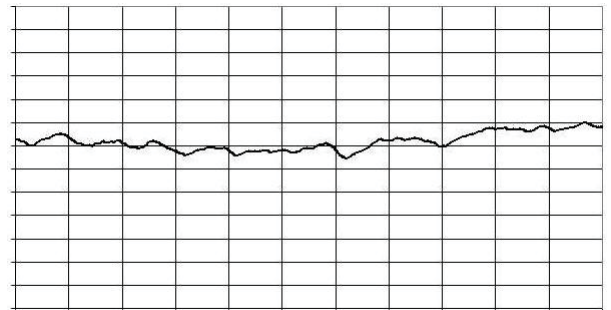

Cogging forces with Parker Trilogy's patent-pending Anti-Cog Technology



## PERFORMANCE

ENCODER	LINEAR MAGNETIC ENCODER			RENISHAW OPTICAL ENCODER	
	1.0 $\mu\text{m}$	5.0 $\mu\text{m}$	0.5 $\mu\text{m}$	1.0 $\mu\text{m}$	5.0 $\mu\text{m}$
Part Number Designator	A	B	M	L	Q
Encoder Model	LME1	LME5	RGH24Z	RGH24X	RGH24D
Peak Velocity	m/s [in/s]	2.5 [100]	7 [275]	3 [120]	5 [200]
Resolution	$\mu\text{m}$ [in]	1.0 [0.00004]	5.0 [0.0002]	0.5 [0.00002]	1.0 [0.00004]
Repeatability	$\mu\text{m}$ [in]	$\pm 2.0$ [ $\pm 0.00008$ ]	$\pm 10.0$ [ $\pm 0.0004$ ]	$\pm 1.5$ [ $\pm 0.00006$ ]	$\pm 2.0$ [ $\pm 0.00008$ ]
Accuracy - LME		$\pm(25 \mu\text{m} + 50 \mu\text{m/m})$	$\pm(30 \mu\text{m} + 50 \mu\text{m/m})$		
Accuracy - Renishaw				$\pm(5 \mu\text{m} + 30 \mu\text{m/m})$	$\pm(10 \mu\text{m} + 30 \mu\text{m/m})$

Note: For travels less than 1 meter, Accuracy should be calculated at 1 meter

MOTOR MODEL		R16-1	R16-2	R16-3
Peak Force	N	2478	4955	7433
	lb	557	1114	1671
Continuous Force	N	743	1487	2230
	lb	167	334	501
Peak Power	W	7065	14130	21195
Continuous Power	W	353	707	1060

## ACCURACY

Base Length	< 1 meter	> 1 meter
Straightness restrained on a flat surface $\mu\text{m}$ [in]	$\pm 127 \mu\text{m/m}$ [ $\pm 0.000127$ in/in]	$\pm 127 \mu\text{m/m}$ [ $\pm 0.000127$ in/in]
Flatness restrained on a flat surface $\mu\text{m}$ [in]	$\pm 330$ [ $\pm 0.013$ ]	$\pm 76 + 254 \mu\text{m/m}$ [ $\pm 0.003 + .000254$ in/in]

Note: Straightness/Flatness specifications based on system mounted to surface of flatness  $\pm 0.0005$  in/ft

## PHYSICAL

COIL SIZE		-1	-2	-3	
Carriage Assembly	TR16	kg [lb]	14.1 [31.0]	24.7 [54.4]	35.3 [77.7]
	BR16	kg [lb]	14.3 [31.5]	25.0 [55.1]	35.8 [78.8]
	Base Assembly (0.625" thick aluminum)				
TR16E	kg/mm [lb/in]	0.0318 [1.778]	-----> ----->		
BR16E	kg/mm [lb/in]	0.0327 [1.825]	-----> ----->		

## LOAD (Recommended)

COIL SIZE		-1	-2	-3
Vertical (Fv) see note 4	kg [lb]	250 [550]	350 [770]	450 [990]
Side (Fs) see note 4	kg [lb]	125 [275]	175 [385]	225 [495]
Moments-Roll (Mr) see note 4	N-m [lb-ft]	125 [92]	175 [129]	225 [166]
Moments-Pitch (Mp) see note 4	N-m [lb-ft]	250 [184]	500 [369]	750 [553]
Moments-Yaw (My) see note 4	N-m [lb-ft]	250 [184]	500 [369]	750 [553]

## NOTES

1. Maximum base length is 3040 mm (limited by maximum single piece bearing rail).
2. Refer to R16 motor data sheet for complete motor specifications.
3. Motor force must be derated by 50% in a "stalled motor" operating condition.
4. Recommended loads based on motor size and typical performance requirements (consult factory if desired loads are greater).
5. Specifications subject to change without notice. Most current brochure available online in PDF format.
6. Refer to website for Ironcore Motor Safe Handling and Cautionary guidelines.

Order Example:

TR 07 A 0480 3 N S B A B 3

**Series**  
TR = Open Positioner  
BR = Bellows Positioner

**Motor Coil Series**  
07 = R07 Motor Coil

**Base Material**  
A = 3/8" Al

**Length of Base** Max.: 3040mm  
Min.: 400mm  
Increment: 80mm  
XXXX = Length of base  
In millimeters

\*Base Length = Travel + 76.2 + Carriage length  
carriage length 1 pole = 218.2 mm  
2 pole = 378.2 mm  
3 pole = 536.2 mm  
Tr only, consult factory for BR length

**Coil Size**  
1 = 1 pole  
2 = 2 pole  
3 = 3 pole

**Cooling**  
N = None

**Winding**  
S Series  
P Parallel (2-pole coil only)  
T Triple (3-pole coil only)

**Cable track**  
0 = None  
3 = Std.

**Cable Connectorization**  
A = Aries  
B = Flying Leads  
C = Compax3  
G = Gemini  
V = ViX  
Z = no Cable  
\*Connectorized cables only available with  
Connector Box

**Cable length**  
A = 1 Meter Flying Leads  
B = 3 Meter Flying Leads  
C = 7.5 Meter Flying Leads  
L = 3 Extension Cables  
(with Connector Box)  
M = 7.5 Extension Cables  
(with Connector Box)  
Z = Connector Box ONLY  
(no extension cables)

\*\*Flying leads – cable measured from  
last cable carrier link  
\*Extension Cables – cable measured  
from connection box at end of base  
\*7.5 Meter Flying Lead Cables  
available on:  
All bases with LME encoder  
All bases with Renishaw encoder  
under 2184mm  
For bases with Renishaw encoder  
over 2184mm the cable length  
(CL) will be  
CL = 10M - (base length in meters  
+ 0.3M)

**Encoder**  
A = LME 1 um  
B = LME 5 um  
Q = Renishaw 5 um  
L = Renishaw 1 u=m  
M = Renishaw 0.5 um  
P = Renishaw 0.1 um  
R = Renishaw IV p-p sine/  
cosine  
X = None

Order Example:

TR 10 B 0480 3 N S B A B 3

**Series**  
 TR = Open Positioner  
 BR = Bellows Positioner

**Motor Coil Series**  
 10 = R10 Motor Coil

**Base Material**  
 B = 1/2" Al

**Length of Base**  
 XXXX = Length of base  
 In millimeters

Max.: 3040mm  
 Min.: 480mm  
 Increment: 60mm

\*Base Length = Travel + 66 + Carriage length  
 carriage length 1 pole = 305.5 mm  
 2 pole = 545.5 mm  
 3 pole = 785.5 mm

Tr only, consult factory for BR length

**Coil Size**  
 1 = 1 pole  
 2 = 2 pole  
 3 = 3 pole

**Cooling**  
 N = None

**Winding**  
 S Series  
 P Parallel (2-pole coil only)  
 T Triple (3-pole only)

**Cable track**  
 0 = None  
 3 = Std.

**Cable Connectorization**  
 A = Aries  
 B = Flying Leads  
 C = Compax3  
 G = Gemini  
 V = ViX  
 Z = no Cable  
 \*Connectorized cables only available with Connector Box

**Cable length**  
 A = 1 Meter Flying Leads  
 B = 3 Meter Flying Leads  
 C = 7.5 Meter Flying Leads  
 L = 3 Extension Cables  
 (with Connector Box)  
 M = 7.5 Extension Cables  
 (with Connector Box)  
 Z = Connector Box ONLY  
 (no extension cables)

\*\*Flying leads – cable measured from last cable carrier link  
 \*Extension Cables – cable measured from connection box at end of base  
 \*7.5 Meter Flying Lead Cables available on:  
 All bases with LME encoder  
 All bases with Renishaw encoder under 2184mm  
 For bases with Renishaw encoder over 2184mm the cable length (CL) will be  
 CL = 10M - (base length in meters + 0.3M)

**Encoder**  
 A = LME 1 um  
 B = LME 5 um  
 Q = Renishaw 5 um  
 L = Renishaw 1 um  
 M = Renishaw 0.5 um  
 P = Renishaw 0.1 um  
 R = Renishaw 1 IV p-p sine/cosine  
 X = None

Order Example:

TR 16 A 0480 3 N S B A B 3

**Series**  
TR = Open Positioner  
BR = Bellows Positioner

**Motor Coil Series**  
16 = R16 Motor Coil

**Base Material**  
A = 5/8" Al

**Length of Base** Max.: 3040mm  
Min.: 480mm  
Increment: 60mm  
XXXX = Length of base  
In millimeters  
\*Base Length = Travel + 80 + Carriage length  
carriage length 1 pole = 305.5 mm  
2 pole = 545.5 mm  
3 pole = 785.5 mm  
Tr only, consult factory for BR length

**Coil Size**  
1 = 1 pole  
2 = 2 pole  
3 = 3 pole

**Cooling**  
N = None

**Winding**  
S Series  
P Parallel (2-pole coil only)  
T Triple (3-pole coil only)

**Cable track**  
0 = None  
3 = Std.

**Cable Connectorization**  
A = Aries  
B = Flying Leads  
C = Compax3  
G = Gemini  
V = ViX  
Z = no Cable  
\*Connectorized cables only available  
with Connector Box

**Cable length**  
A = 1 Meter Flying Leads  
B = 3 Meter Flying Leads  
C = 7.5 Meter Flying Leads  
L = 3 Extension Cables  
(with Connector Box)  
M = 7.5 Extension Cables  
(with Connector Box)  
Z = Connector Box ONLY  
(no extension cables)  
  
\*\*Flying leads – cable measured from  
last cable carrier link  
\*Extension Cables – cable measured  
from connection box at end of base  
\*7.5 Meter Flying Lead Cables  
available on:  
All bases with LME encoder  
All bases with Renishaw encoder  
under 2184mm  
For bases with Renishaw encoder  
over 2184mm the cable length  
(CL) will be  
CL = 10M - (base length in meters  
+ 0.3M)

**Encoder**  
A = LME 1 um  
B = LME 5 um  
Q = Renishaw 5 um  
L = Renishaw 1 um  
M = Renishaw 0.5 um  
P = Renishaw 0.1 um  
R = Renishaw IV p-p  
sine/cosine  
X = None

# ***Precision Grade Linear Motors***



## Features

- Velocity to 4.5 m/sec
- Acceleration to 5 Gs
- Encoder resolution to 0.1 micron
- Cleanroom compatible
- Easy multi-axis mounting
- Cable management system
- Proven strip seal



### Performance Matched Components

The 400LXR Series linear servo motor tables achieve optimum performance by combining slotless or ironcore motor technology with performance matched mechanical elements and feedback devices. Fast response, high acceleration, smooth translation, high velocity, and quick settling time describe the performance characteristics found in the 400LXR while high repeatability, precise accuracy, and sub-micron resolution define the positioning attributes.

### Sized to fit



The 400LXR Tables are offered in three widths (100, 150, and 300 mm), and travel lengths up to 3 meters to accommodate the size and performance requirements of many industries

including life sciences, photonics, semiconductor and general automation.

### “Designer Friendly” Features and Options

A vast assortment of “designer friendly” features and options simplify the engineering challenges often confronted with “base model” positioning devices. Features like the IP30 protective strip seal and long life cable management system, exemplify the built-in value found in the 400LXR units. Other selectable enhancements like cleanroom compatibility, travel limit sensors, motor drives, encoder resolution, and pinning holes for tooling location, simplify machine design and integration efforts.



### Flexibility and Multi-Axis Compatibility

The 400LXR’s selection flexibility and mounting compatibility with the 400XR ballscrew driven tables enables single axis or complex multi-axis units to be configured in a straightforward manner. Parker’s matching servo drives and motion controllers can be included to complete the motion system.



### Customs and Systems

For specialized applications requiring customization, Parker design engineers can easily modify these tables to suit, or engineer complete interactive linear motion systems to desired specifications. Parker’s 400LXR series tables have taken the mystery, difficulty and cost out of integrating linear motor tables into high throughput precision positioning applications.

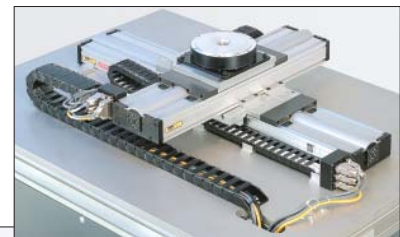



## Specifications

Model Motor	404LXR 8 Pole	406LXR 8 Pole	406LXR 12 Pole	412LXR 12 Pole	412LXR 24 Pole (no cooling)
Rated Load kg (lb)	45(99)	180(396)	180(396)	950(2090)	1148(2526)
Maximum Acceleration	5 Gs				
Maximum Velocity (m/sec.)					
Encoder Resolution: 0.1 µm	0.3	0.3	0.3	0.3	0.3 [0.3]*
0.5 µm	1.5	1.5	1.5	1.5	1.5 [1.5]*
1.0 µm	3.0	3.0	3.0	3.0	2.0 [3.0]*
5.0 µm	3.0	3.0	3.0	3.0	2.0 [4.5]*
Sine Output	3.0	3.0	3.0	3.0	2.0 [4.5]*
Positional Repeatability					
Encoder Resolution: 0.1 µm	+ 1.0 µm				
0.5 µm	+ 1.0 µm				
1.0 µm	+ 2.0 µm				
5.0 µm	+10.0 µm				
Sine Output	(interpolation dependent)				
Peak Force N (lb)	180 (40)	225 (50)	330 (75)	1000 (225)	2650 (595)
Continuous Force N (lb)	50 (11)	75 (17)	110 (25)	355 (80)	750 (169)
Carriage Mass (kg)	1.4	3.2	4.1	12.3	23



\* Bracketed velocity values [ ] apply to 675VDC bus (480 VAC drive input).

## Travel Dependent Specifications

Travel (mm)	Accuracy* (µm)			Unit Weight (Kg)				
	Positional		Straightness & Flatness Accuracy* (µm)	404LXR 8 Pole	406LXR 8 Pole	406LXR 12 Pole	412LXR 12 Pole	412LXR 24 Pole
	0.1,0.5,1.0 resolution (µm)	5.0 resolution (µm)						
50	6	16	6	4.4	8.7	11.1	-	-
100	7	17	6	4.8	-	-	-	-
150	8	18	9	5.2	10.3	13.4	41	-
200	10	20	10	5.6	-	-	-	49
250	12	22	12	6.0	12.6	14.1	45	-
300	14	24	13	6.4	-	-	-	-
350	16	26	15	6.8	13.3	15.7	49	-
400	18	28	16	7.2	-	-	-	-
450	20	30	18	-	14.8	17.2	-	-
500	21	31	19	8.0	-	-	-	61
550	23	33	21	-	16.4	18.7	-	-
600	25	35	22	8.9	-	-	-	-
650	26	36	24	-	17.9	20.2	61	67
700	28	38	25	9.7	-	-	-	-
750	29	39	27	-	19.4	21.8	-	-
800	31	41	29	10.6	-	-	67	-
850	32	43	30	-	20.9	23.3	-	75
900	33	44	32	11.5	-	-	-	-
950	34	44	33	-	22.5	-	-	-
1000	35	45	35	12.4	-	27.1	75	-
1050	37	47	36	-	-	-	-	83
1200	39	49	41	-	26.3	-	83	-
1350	42	52	45	-	-	30.9	-	95
1450	43	53	48	-	30.1	-	-	-
1500	44	54	50	-	-	-	95	-
1600	45	55	53	-	-	34.7	-	105
1700	46	56	56	-	33.9	-	-	-
1750	46	56	57	-	-	-	105	-
1850	47	57	60	-	-	38.6	-	113
1950	48	58	63	-	37.7	-	-	-
2000	48	58	65	-	-	-	113	-
2350	49	59	76	-	-	-	-	133
2500	50	60	80	-	-	-	133	-
2850	50	60	84	-	-	-	-	153
3000	50	60	84	-	-	-	153	-

\* Accuracy stated is at 20 degrees C, utilizing slope correction factor provided

## Encoder Specifications

Description	Specification
Input Power	5 VDC +/- 5% 150 mA
Output (Incremental)	Square wave differential line driver (EIA RS422) 2 channels A and B in quadrature (90) phase shift.
Reference (Z channel)	Synchronized pulse, duration equal to one resolution bit. Repeatability of position is unidirectional moving toward positive direction.

## Limit and Home Sensor Specifications

Description	Specification
Input Power	+5 to +24 VDC 60 mA (20 mA per sensor)
Output	Output form is selectable with product: Normally Closed Current Sinking Normally Open Current Sinking Normally Closed Current Sourcing Normally Open Current Sourcing All types Sink or Source maximum of 50 mA
Repeatability	Limits: +/- 10 microns (unidirectional) Home: See Z channel specifications

## Hall Effect Specifications

Description	Specification
Input Power	+5 to +24 VDC, 30 mA
Output	Open Collector, Current Sinking, 20 mA Max

### Cable Transport Module

The LXR's Cable Transport Module offers the convenience of "plug and play" connectivity for fast, easy table installation and "quick change" replacement. This system of cable management includes the highest quality high-flex ribbon cable with a life rating of 30 million cycles, a cable track with support brackets, a "quick change" carriage cartridge, and a plug-in connector panel housing. It also provides a "pass-through" connection and cabling for customer application. This transport module option is ideal for high throughput continuous duty requirements where downtime is not acceptable.

The high-flex ribbon cable permits a cable track bend radius that is small enough to clear payloads of large dimension. The cable transport can be ordered with a variety of extension cable options. These cables provide extensions from the connector panel on the cable transport module, to the motor drive amplifier and controller. The cables are high-flex, long life cables so they can be utilized on a second or third axis unit.

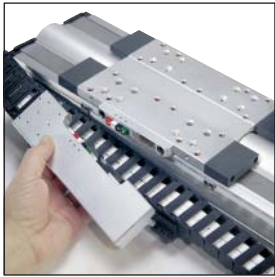

"Quick Change" Cartridge

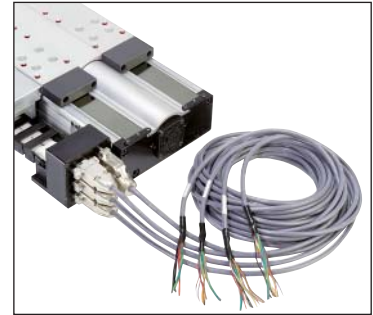

Cable Extensions – Flying Leads Terminations

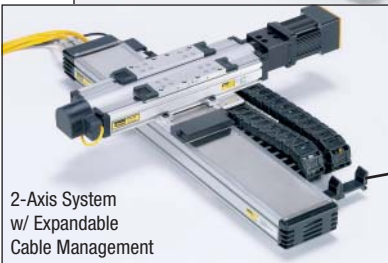

2-Axis System w/ Expandable Cable Management

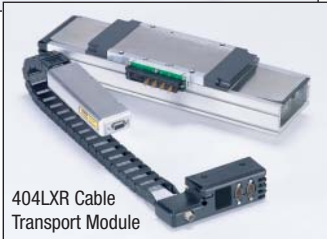

404LXR Cable Transport Module

#### Cable Transport Module – Order Code

Order Code	Extension Cable Length	Extension Cable Termination
CM02	No Extension Cables	
CM07	3.0 meters	flying leads
CM08	7.5 meters	flying leads
CM09	3.0 meters	Gemini Conn.
CM10	7.5 meters	Gemini Conn.
CM13	3.0 meters	Aries/Vix Conn.
CM14	7.5 meters	Aries/Vix Conn.
CM22*	3.0 meters	Compax Conn.
CM23*	7.5 meters	Compax Conn.

\* 24 Pole motor models only

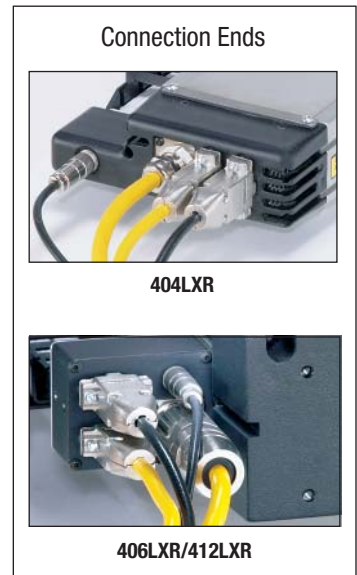

Connection Ends

404LXR

406LXR/412LXR



## OEM Cable System

The LXR's unharnessed cable system is offered for OEMs and others who have independent methods of routing and managing cables. These systems offer the “quick change” cartridge, “pass-through” connection and round high-flex cables in lengths of 3.0 or 7.5 meters. They are available with flying lead end terminations, Gemini, Aries, or Compax3 Connectors.



### OEM Cable System – Order Code

Order Code	Extension Cable Length	Extension Cable Termination
CM03	3.0 meters	flying leads
CM04	7.5 meters	flying leads
CM05	3.0 meters	Gemini Conn.
CM06	7.5 meters	Gemini Conn.
CM11	3.0 meters	Aries/Vix Conn.
CM12	7.5 meters	Aries/Vix Conn.
CM20*	3.0 meters	Compax Conn.
CM21*	7.5 meters	Compax Conn.

\* 24 Pole motor models only



406LXR with OEM cables and flying leads

## User “Pass-Through” Cabling Feature



- Pre-wired plug-in connection to the moving payload
- Nine user conductors for end-effectors or instruments
- High-Flex long life cables:  
Ribbon Cable – Transport Module System  
Round Cable – OEM System

Cable concerns regarding routing and durability for payload or instrument signals are addressed by the pass-through connectivity feature included with both of the LXR cable management systems. Nine pin D-connectors provided on the carriage (with the transport module units) and the cable connecting block combine with high-flex, long life cables for easy setup and dependable performance.

**Note:** Extension Cables are available and can be ordered separately:  
006-1743-01 (3 meters); 006-1743-02 (7.5 meters).

## 400LXR Cleanroom Preparation R2

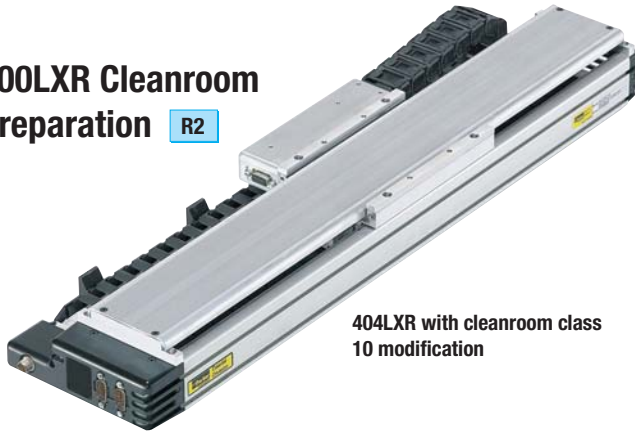

404LXR with cleanroom class 10 modification

Cleanroom compatible linear tables are often required for laboratory and production applications in industries such as semiconductor, life science, electronics, and pharmaceuticals.

400LXR tables with cleanroom preparation, were tested in Parker's vertical laminar flow work station, which utilizes ULPA filters to produce an environment having a cleanliness of class 1 prior to testing. Tables were tested in a variety of orientations with sampling both below the table and at the carriage mounting surface. Laminar flow rate is 0.65 inches W.C.

Special cleanroom testing can be provided upon request. For more information on cleanroom testing, contact a Parker Applications Engineer at 800-245-6903.

### Standard Cleanroom Preparation

- Stringent cleaning and handling measures
- Cleanroom rated lubrication
- Strip seal replaced with hard shell cover

### 400LXR Cleanroom Compatibility

Table Velocity	Class	
	4.5" below table	At carriage surface
250	mm/sec	10 1
500	mm/sec	25 1
1000	mm/sec	50 5
2000	mm/sec	250 25
3000	mm/sec	500 100



Testing at 4.5 inches below table

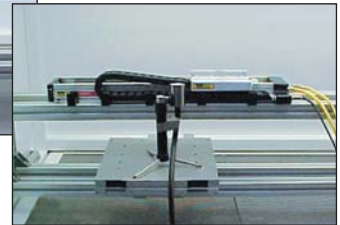

Testing at carriage mounting surface

### About Cleanrooms

A room in which the concentration of airborne particles is controlled within defined limits. Federal Standard 209E statistically defines the allowable number of particles per cubic foot of air.

The chart (right) describes the conditions that must be maintained for the cleanroom to have a specific "class" rating.

Class	Number of Allowable Particles				
	0.1	0.2	0.3	0.5	5
	(Measured particle size in microns [µm])				
1	35	7.5	3	1	0
10	350	75	30	10	0
100	n/a	750	300	100	0
1000	n/a	n/a	n/a	1000	7
10000	n/a	n/a	n/a	10000	70
100000	n/a	n/a	n/a	100000	700

## Dowel Pinning P\_

Standard dowel pin locating holes P1 are offered on all 400LXR units to facilitate repeatable mounting of tooling or payload.

In addition, pinning options P2 & P3 are offered for precise orthogonal mounting of the second axis in a multi-axis system. In this case, the bottom side of the table base is match drilled and reamed to the first axis to provide exact orthogonal location. This convenient option eliminates concerns regarding contamination or damage often associated with machining for locating pins in an assembled unit.



Two locating dowel holes (P1 option) shown in 404LXR carriage





# 404LXR Series Dimensions (mm)

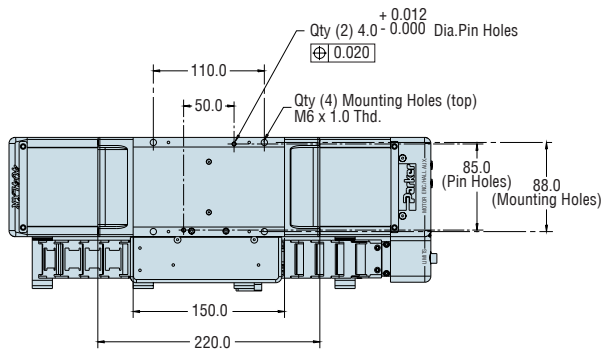

**Top View  
(With Cable Transport Module)**

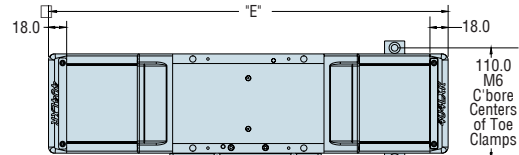

OEM Cables (Strip Seal/Hardcover)

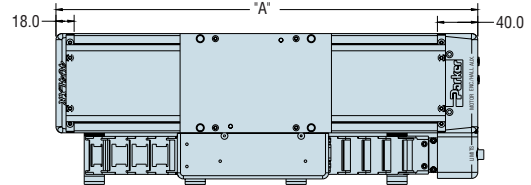

Cable Module (Strip Seal/Hardcover)

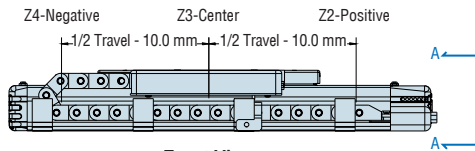

**Front View  
Z-Channel Location**

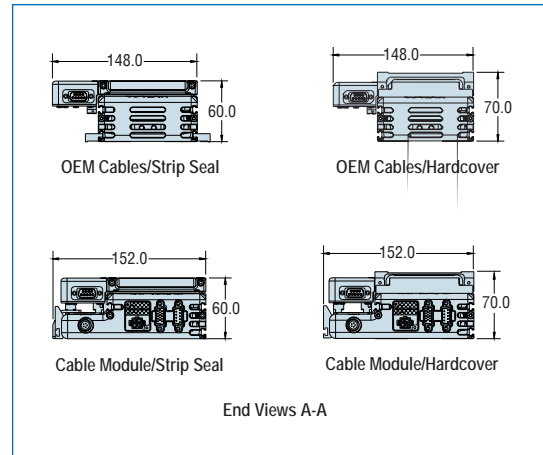

End Views A-A

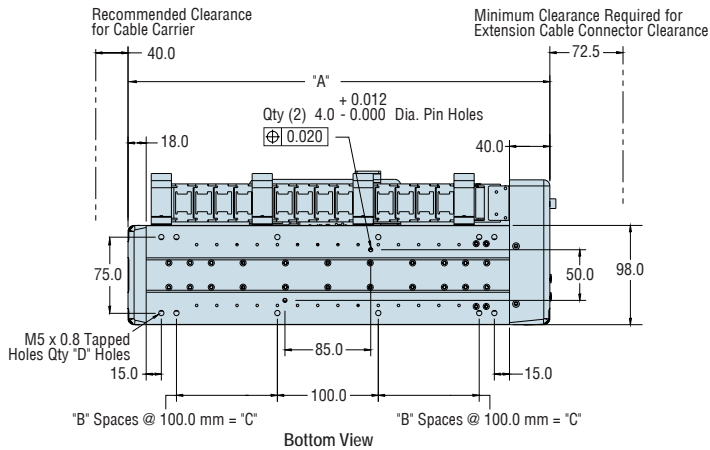

**Bottom View**



Model	Travel (mm)	Dim A	B	C	D	E
404T00LXR	50	368.0	1	100.0	12	346.0
404T01LXR	100	418.0	1	100.0	12	396.0
404T02LXR	150	468.0	1	100.0	12	446.0
404T03LXR	200	518.0	1	100.0	12	496.0
404T04LXR	250	568.0	1	100.0	12	546.0
404T05LXR	300	618.0	2	200.0	16	596.0
404T06LXR	350	668.0	2	200.0	16	646.0
404T07LXR	400	718.0	2	200.0	16	696.0
404T09LXR	500	818.0	3	300.0	20	796.0
404T11LXR	600	918.0	3	300.0	20	896.0
404T13LXR	700	1018.0	4	400.0	24	996.0
404T15LXR	800	1118.0	4	400.0	24	1096.0
404T17LXR	900	1218.0	5	500.0	28	1196.0
404T19LXR	1000	1318.0	5	500.0	28	1296.0

Order Example

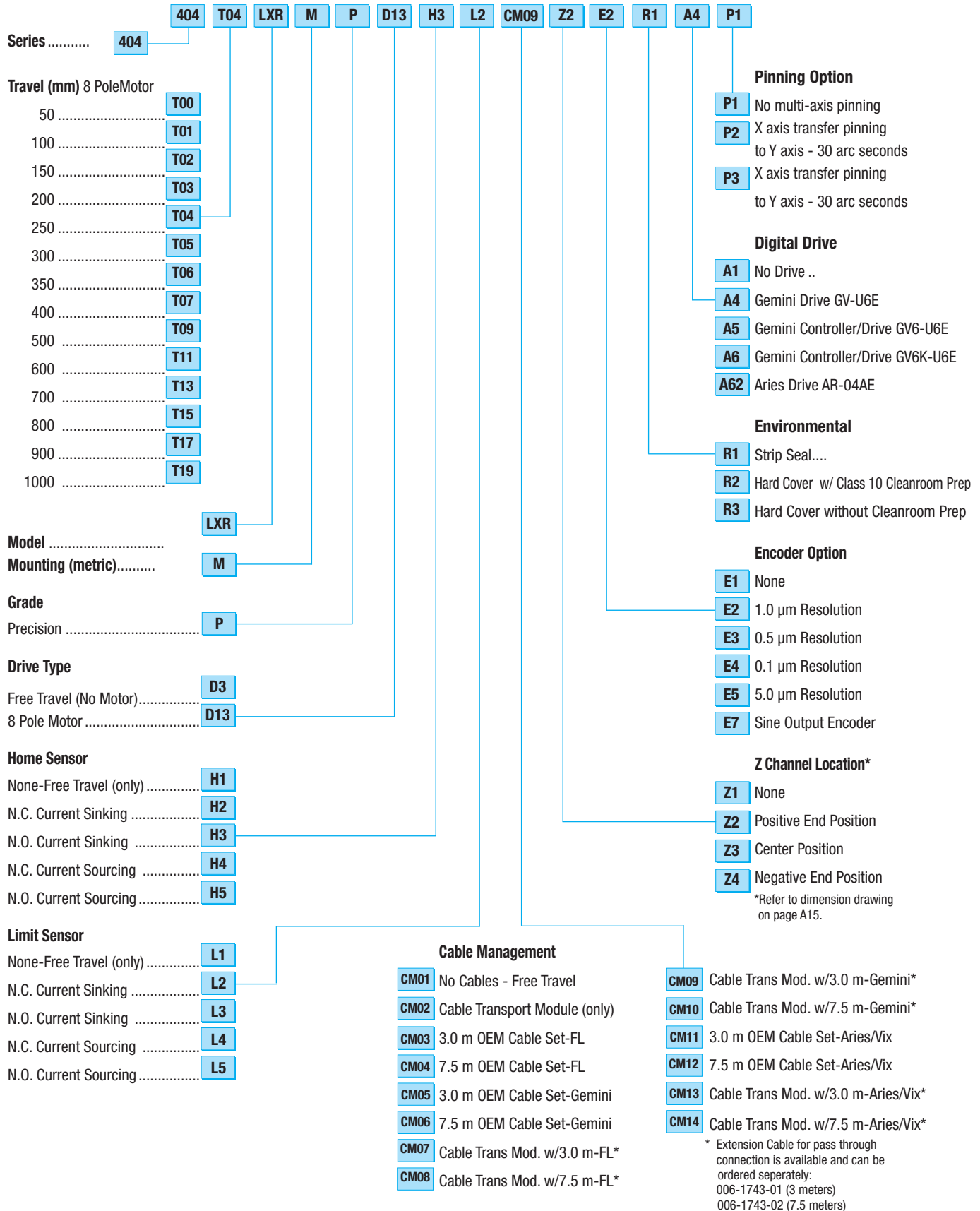



# 406LXR Series Dimensions (mm)

## 12 Pole Slotless Motor

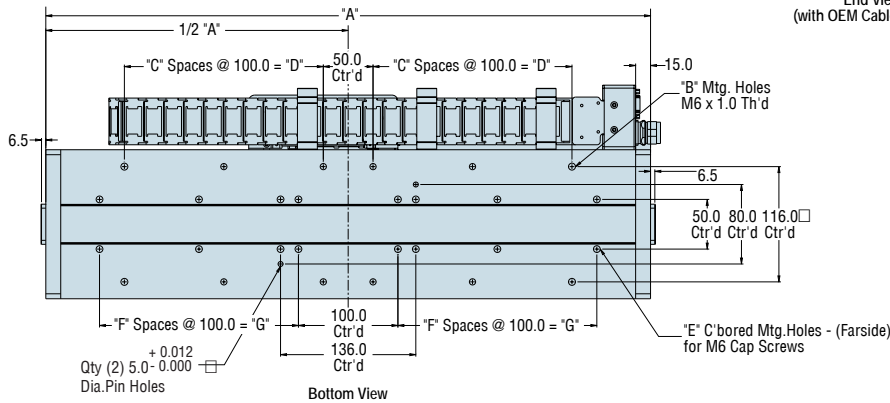
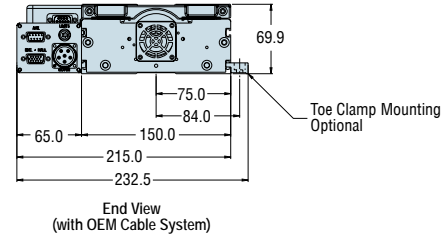
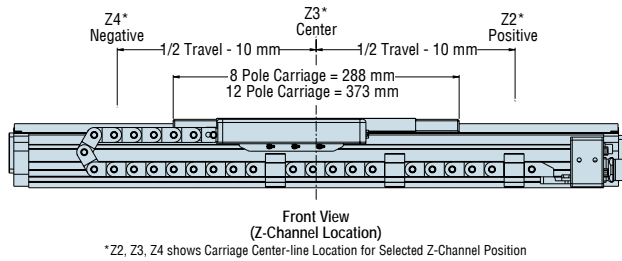
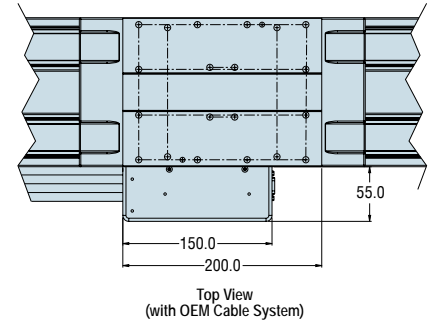
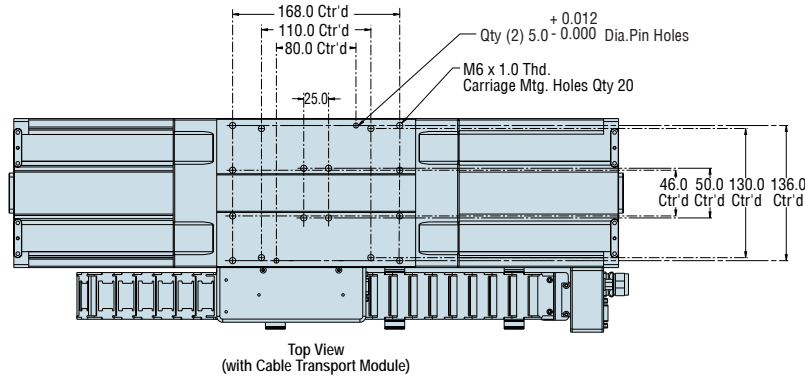

Model	Travel (mm) 8 Pole	Travel (mm) 12 Pole	A	B	C	D	E	F	G
406T01LXR	50	N/A	408	8	1	100.0	12	1	100.0
406T02LXR	150	50	508	8	1	100.0	12	1	100.0
406T03LXR	250	150	608	12	2	200.0	16	2	200.0
406T04LXR	350	250	708	12	2	200.0	16	2	200.0
406T05LXR	450	350	808	16	3	300.0	20	3	300.0
406T06LXR	550	450	908	16	3	300.0	20	3	300.0
406T07LXR	650	550	1008	20	4	400.0	24	4	400.0
406T08LXR	750	650	1108	20	4	400.0	24	4	400.0
406T09LXR	850	750	1208	24	5	500.0	28	5	500.0
406T10LXR	950	850	1308	24	5	500.0	28	5	500.0
406T11LXR	1200	1100	1558	32	7	700.0	32	6	600.0
406T12LXR	1450	1350	1808	36	8	800.0	40	8	800.0
406T13LXR	1700	1600	2058	40	9	900.0	44	9	900.0
406T14LXR	1950	1850	2308	44	10	1000.0	48	10	1000.0

Order Example

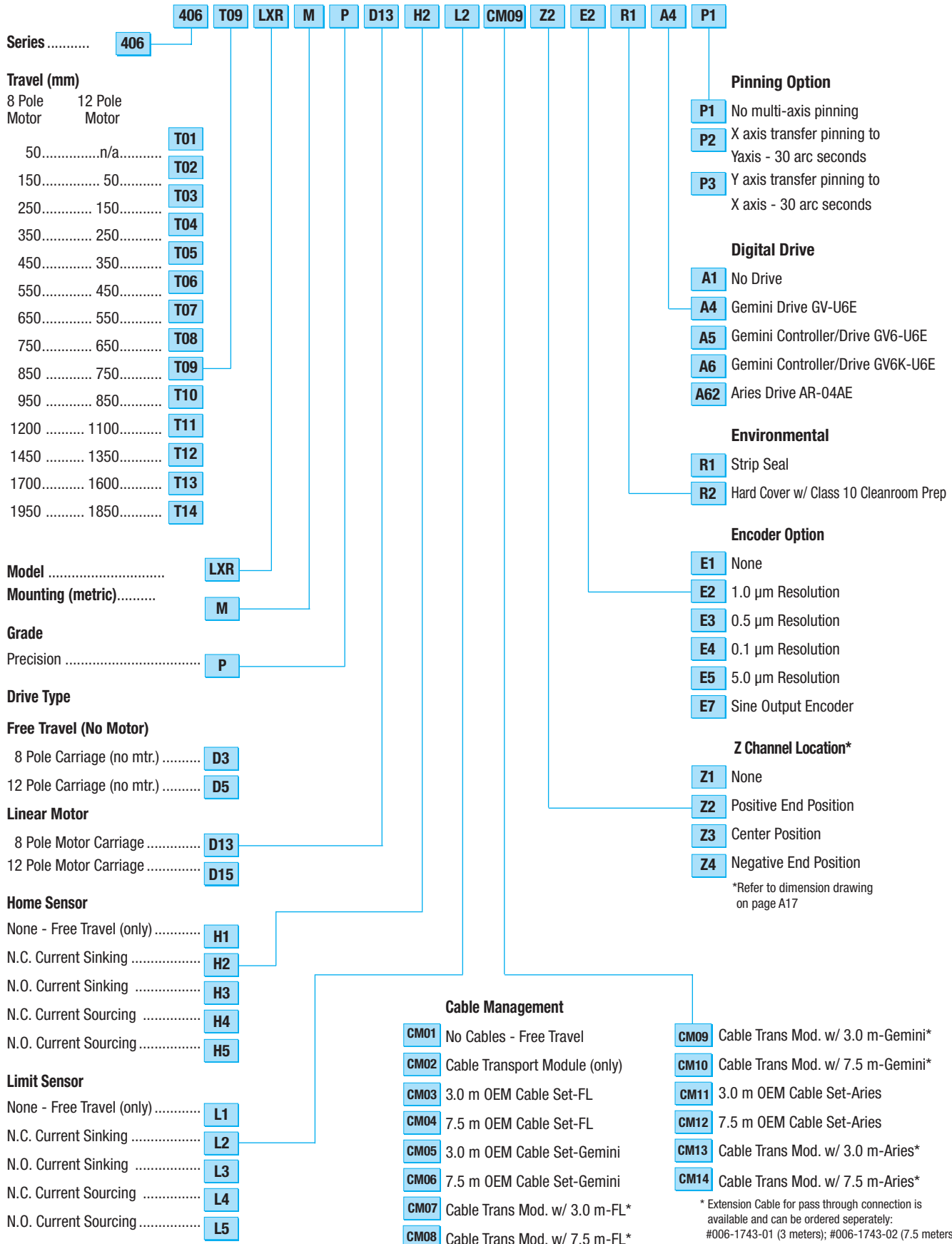



# 412LXR-D15 Series Dimensions (mm)

## 12 Pole Slotless Motor

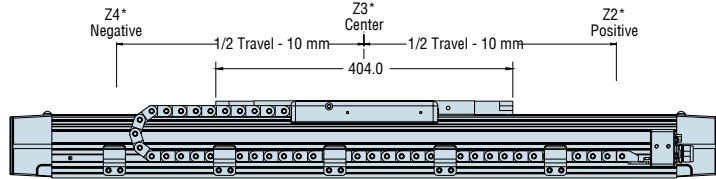
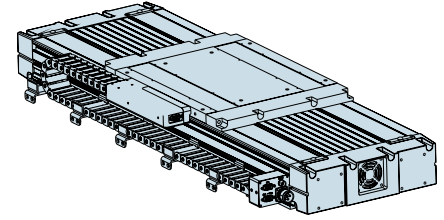
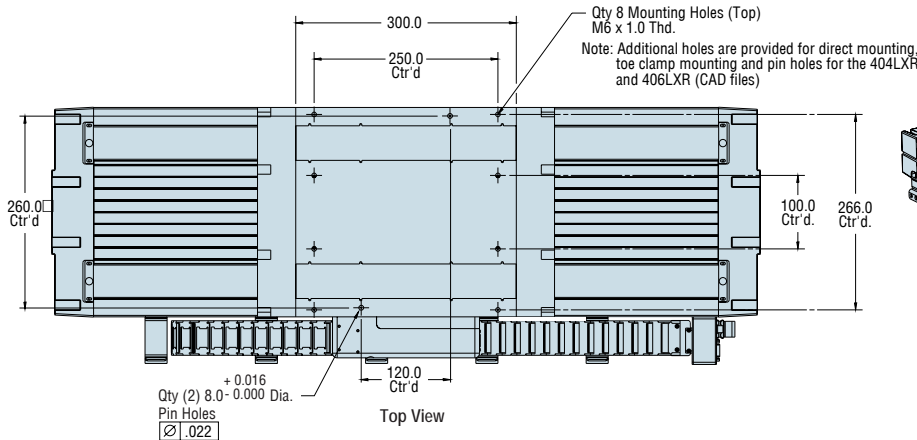

\*Z2, Z3, Z4 shows Carriage Center-line Location for Selected Z-Channel Position

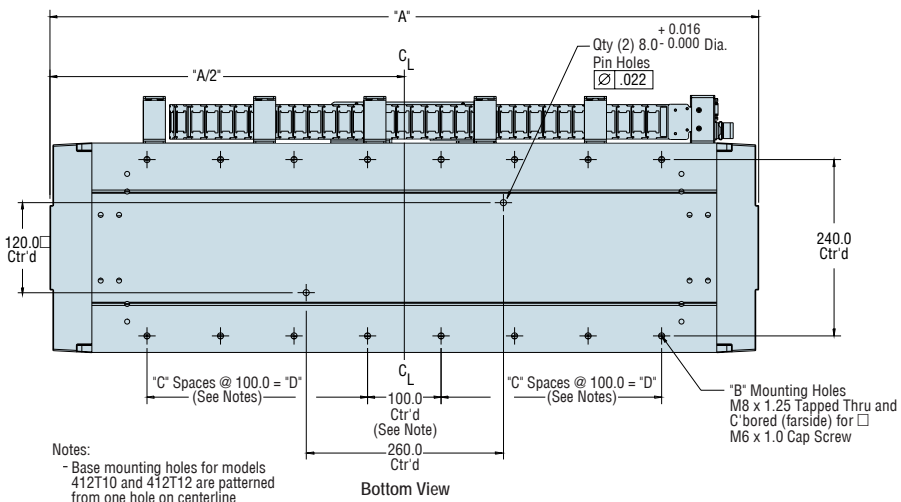
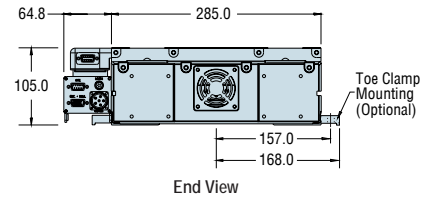

Notes:  
- Base mounting holes for models 412T10 and 412T12 are patterned from one hole on centerline



Model	Travel (mm)	A	B	C	D
412T01LXRD-15	150	764	12	2	200
412T02LXRD-15	250	864	16	3	300
412T03LXRD-15	350	964	16	3	300
412T04LXRD-15	650	1264	24	5	500
412T05LXRD-15	800	1414	24	5	500
412T06LXRD-15	1000	1614	28	6	600
412T07LXRD-15	1200	1814	32	7	700
412T08LXRD-15	1500	2114	40	9	900
412T09LXRD-15	1750	2364	44	10	1000
412T10LXRD-15	2000	2614	50	12	1200
412T11LXRD-15	2500	3114	60	14	1400
412T12LXRD-15	3000	3614	70	17	1700



12 Pole Slotless Linear Motor

Order Example

412 T09 LXR M P D15 H3 L3 CM09 Z2 E2 R1 A7 P1

- Series ..... 412
- Travel (mm) 12 Pole Motor
- 150..... T01    1200..... T07
  - 250..... T02    1500..... T08
  - 350..... T03    1750..... T09
  - 650..... T04    2000..... T10
  - 800..... T05    2500..... T11
  - 1000.... T06    3000..... T12

- Model ..... LXR
- Mounting (metric) ..... M
- Grade
- Precision ..... P
- Drive Type
- Free Travel (No Motor)..... D5
- 12 Pole Motor ..... D15

Refer to page A22 for 24 pole iron core motor drive.

- Home Sensor**
- None-Free Travel (only) ..... H1
- N.C. Current Sinking ..... H2
- N.O. Current Sinking ..... H3
- N.C. Current Sourcing ..... H4
- N.O. Current Sourcing ..... H5

- Limit Sensor**
- None-Free Travel (only) ..... L1
- N.C. Current Sinking ..... L2
- N.O. Current Sinking ..... L3
- N.C. Current Sourcing ..... L4
- N.O. Current Sourcing ..... L5

- Cable Management**
- No Cables - Free Travel..... CM01
  - Cable Transport Module (only)..... CM02
  - 3.0 m OEM Cable Set-FL..... CM03    Cable Trans Mod. w/ 3.0 m-Gemini\*..... CM09
  - 7.5 m OEM Cable Set-FL..... CM04    Cable Trans Mod. w/ 7.5 m-Gemini\*..... CM10
  - 3.0 m OEM Cable Set-Gemini..... CM05    3.0 m OEM Cable Set-Aries..... CM11
  - 7.5 m OEM Cable Set-Gemini..... CM06    7.5 m OEM Cable Set-Aries..... CM12
  - Cable Trans Mod. w/ 3.0 m-FL\* ..... CM07    Cable Trans Mod. w/ 3.0 m-Aries\*..... CM13
  - Cable Trans Mod. w/ 7.5 m-FL\* ..... CM08    Cable Trans Mod. w/ 7.5 m-Aries\*..... CM14

- Pinning Option**
- P1 No multi-axis pinning
  - P2 X axis transfer pinning to Y axis- 30 arc seconds
  - P3 Y axis transfer pinning to X axis - 30 arc seconds\*
- \*P3 Option includes a required 15 mm thick adapter.
- Digital Drive**
- A1 No Drive
  - A7 Gemini Drive GV-U12E
  - A8 Gemini Controller/Drive GV6-U12E
  - A9 Gemini Controller/Drive GV6K-U12E
  - A63 Aries Drive AR-08AE

- Environmental**
- R1 Class 1000, Strip Seals
  - R2 Class 10 Cleanroom Prep

- Encoder**
- E1 None
  - E2 1.0 µm Resolution Linear
  - E3 0.5 µm Resolution Linear
  - E4 0.1 µm Resolution Linear
  - E5 5.0 µm Resolution Linear
  - E7 Sine Output Encoder

- Z Channel Location\***
- Z1 None
  - Z2 Positive End Position
  - Z3 Center Position
  - Z4 Negative End Position

\*Refer to dimension drawing on page A19.



\* Extension Cable for pass through connection is available and can be ordered separately: #006-1743-01 (3 meters); #006-1743-02 (7.5 meters).



## MX80L Miniature Linear Motor Stages

### Features

- Miniature size
- 5g acceleration
- Fast settling
- Submicron precision
- High velocity (2 m/sec.)
- Multi-axis platform

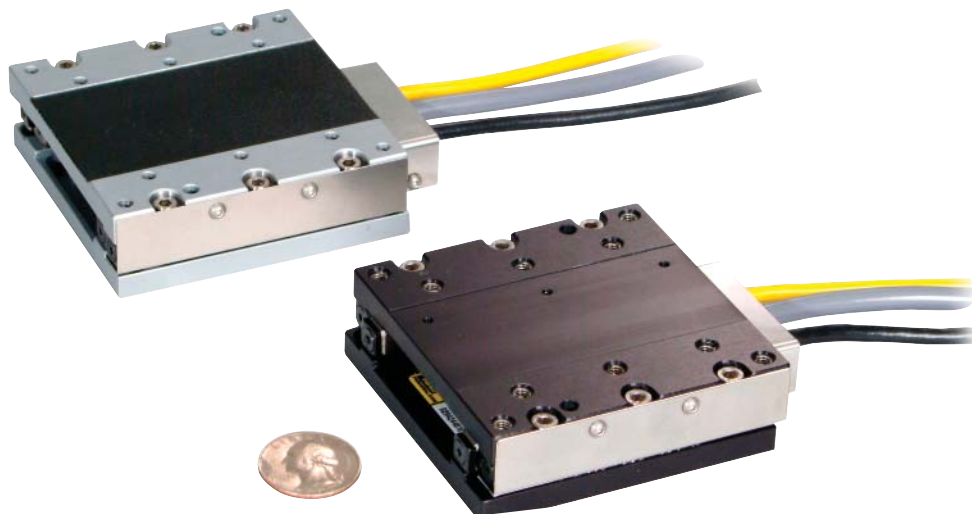

### Attributes:

- Low profile miniature size - (25 mm high X 80 mm wide)
- Linear servo motor drive
- Six linear encoder resolutions (0.01  $\mu\text{m}$  to 5.0  $\mu\text{m}$ )
- 25, 50, 100, 150 mm travels
- Cross Roller bearing (zero cage creep design)
- Precision or standard grade
- Cleanroom and low ESD options
- Fully adjustable home and limit sensors
- Dowel holes for repeatable mounting of payload
- Master reference surface to travel path
- “Plug-in” intelligent drive
- Pneumatic z-axis counterbalance
- No moving cables

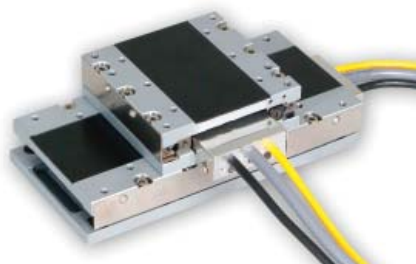

### Introduction

Miniaturization of fiber optics, photonics, electronics and biomedical processes has driven the need for smaller and more efficient positioners. Parker’s MX80 miniature stage, the smallest linear servomotor driven positioner in the industry, is loaded with high performance features for both rapid linear translation and precise positioning of lighter loads in small work envelopes. Designed for today’s 24/7 production demands, the MX80 has redefined “high-throughput automation” in the world of miniature positioners.

High Performance in a small package: While the MX80 is small in size, it is large on performance and reliability. All key components are “built-in” - residing within the body of the stage to provide a clean looking, reliable, unobstructed package. At the heart of the MX80 is an innovative non-contact linear servo motor (patent pending). This direct drive motor has been optimized for force, speed, and acceleration, to deliver outstanding performance and response. A high precision non-contact linear encoder provides submicron resolution, repeatability and accuracy.

Selectable resolutions range from 10 nanometers to 5 microns. Precision ground cross roller bearing sets with a “zero cage creep” feature provide extremely smooth - precise linear translation. Digital Hall effect travel limit and home sensors are conveniently designed into the unit for easy adjustment over the entire travel of the stage. Although there are no moving cables, a meter of hi-flex cabling is included and wired directly into the units. This hi-flex cabling addresses cable flexing concerns associated with the second or third axis in multi-axis system.

## MX80L Miniature Linear Motor Stages

### Precision Series

**Precision grade** models are designed for high performance applications requiring the highest degree of positioning accuracy. They offer a steel body design with precisely ground mounting surfaces & bearing ways. They include higher resolution linear encoders, and are slope corrected, laser tested and certified for optimum precision.

- 4g acceleration
- Repeatability to  $\pm 0.4 \mu\text{m}$
- Straightness  $\pm 0.4 \mu\text{m}$
- Steel body construction
- Precision ground mounting and bearing surfaces
- Hard chrome protective finish



### Standard Series

**Standard grade** units offer a lower cost alternative for applications requiring high throughput performance with less demanding positioning requirements. They are constructed of high alloy aluminum, providing a lighter weight design which can accelerate to 5 g's.

- 5g acceleration
- Repeatability to  $\pm 0.8 \mu\text{m}$
- Straightness  $\pm 0.8 \mu\text{m}$
- Light weight aluminum body
- Low luster black anodize finish



## Specifications:

	Travel			
	25mm	50mm	100mm	150mm
<b>Normal Load Capacity</b>	8kg(18 lb)	8kg(18 lb)	8kg(18 lb)	8kg(18 lb)
<b>Maximum Acceleration</b>				
<b>Precision Grade</b>	4g	4g	4g	3g
<b>Standard Grade</b>	5g	5g	5g	4g
<b>Maximum Velocity</b>				
5.0µm resolution	1100 mm/sec	1500 mm/sec	2000 mm/sec	2000 mm/sec
1.0µm resolution	1100 mm/sec	1500 mm/sec	2000 mm/sec	2000 mm/sec
0.5µm resolution	1100 mm/sec	1500 mm/sec	1500 mm/sec	1500 mm/sec
0.1µm resolution	300 mm/sec	300 mm/sec	300 mm/sec	300 mm/sec
0.02µm resolution	60 mm/sec	60 mm/sec	60 mm/sec	60 mm/sec
0.01µm resolution	30 mm/sec	30 mm/sec	30 mm/sec	30 mm/sec
<b>Peak Force</b>	12N (2.7 lb)	12N (2.7lb)	24N (5.4 lb)	24N (5.4 lb)
<b>Continuous Force</b>	4N (.9 lb)	4N (.9 lb)	8N (1.8 lb)	8N (1.8 lb)
<b>Duty Cycle</b>	100%	100%	100%	100%
<b>Straightness &amp; Flatness</b>				
<b>Precision Grade</b>	4 microns	4 microns	5 microns	6 microns
<b>Standard Grade</b>	6 microns	6 microns	10 microns	12 microns
<b>Positional Accuracy</b>				
<b>Precision Grade</b> <sup>(1)(2)(3)</sup>				
0.01 µm resolution	3 microns	4 microns	5 microns	5 microns
0.02 µm resolution	3 microns	4 microns	5 microns	5 microns
0.1 µm resolution	3 microns	4 microns	5 microns	5 microns
0.5 µm resolution	4 microns	5 microns	6 microns	6 microns
1.0 µm resolution	5 microns	6 microns	7 microns	7 microns
5.0 µm resolution	13 microns	14 microns	15 microns	15 microns
<b>Standard Grade</b> <sup>(2)</sup>				
0.01 µm resolution	12 microns	15 microns	20 microns	20 microns
0.02 µm resolution	12 microns	15 microns	20 microns	20 microns
0.1 µm resolution	12 microns	15 microns	20 microns	20 microns
0.5 µm resolution	12 microns	15 microns	20 microns	20 microns
1.0 µm resolution	15 microns	20 microns	25 microns	25 microns
5.0 µm resolution	25 microns	30 microns	35 microns	35 microns
<b>Bi-directional Repeatability</b>				
<b>Precision Grade</b> <sup>(1)(2)(3)</sup>				
0.01 µm resolution			+0.4 microns	
0.02 µm resolution			+0.4 microns	
0.1 µm resolution			+0.5 microns	
0.5 µm resolution			+1.0 microns	
1.0 µm resolution			+2.0 microns	
5.0 µm resolution			±10.0 microns	
<b>Standard Grade</b> <sup>(2)</sup>				
0.01 µm resolution			+0.8 microns	
0.02 µm resolution			+0.8 microns	
0.1 µm resolution			+0.8 microns	
0.5 µm resolution			+1.5 microns	
1.0 µm resolution			+2.0 microns	
5.0 µm resolution			±10.0 microns	
<b>Unit Mass</b>				
<b>Precision Grade</b>	590g	590g	1027g	1345g
<b>Standard Grade</b>	475g	475g	875g	1125g
<b>Carriage Mass (unloaded)</b>				
<b>Precision Grade</b>	282g	282g	509g	676g
<b>Standard Grade</b>	213g	213g	405g	537g

(1) Measured at the carriage center, 35mm above the mounting surface @ 20 C with no load. Unit bolted to granite surface, flat to within 1micron/300mm.

(2) Total accuracy and bi-directional repeatability over full travel (peak to peak).

(3) Precision grade with slope correction value provided. Consult factory if better accuracy is required.

# MX80L Miniature Linear Motor Stage

## Specifications:

### How we measure accuracy:

All published linear table accuracy and repeatability specifications vary according to testing and reporting methodology. Parker methodology includes data reporting over the entire table travel length, regardless of the start or stop position.

Testing is performed with the table unloaded and mounted to a stable granite surface, at 20° C. Accuracy and repeatability specifications are based on a peak to peak range of error, measured by a laser interferometer with the beam located 35mm above the center of the table top. The reported error totals six degrees of freedom (x,y,z, plus roll, pitch and yaw errors). Final table specifications are established from the maximum positive (+) error to the maximum negative (-) error.

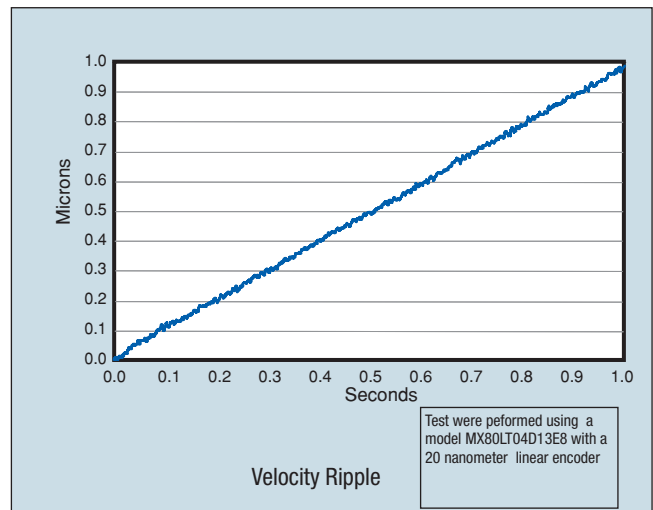
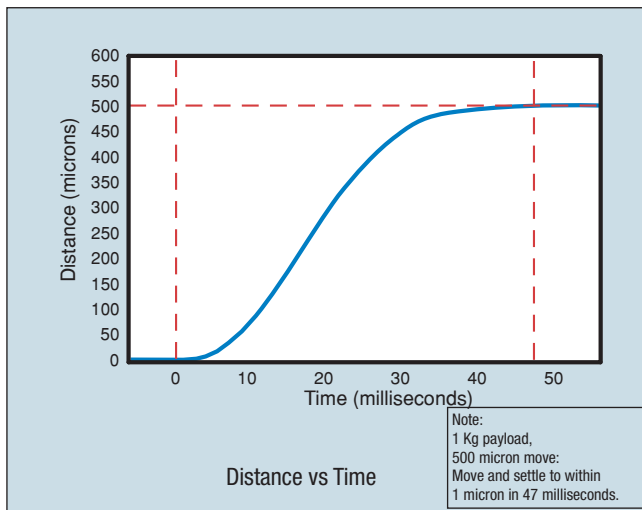
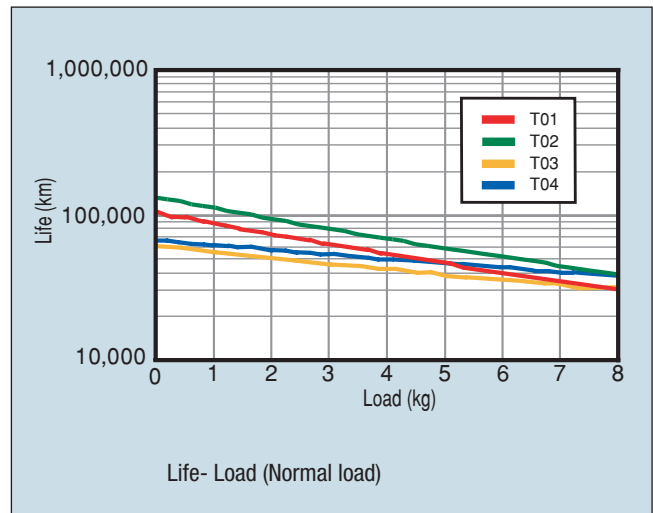
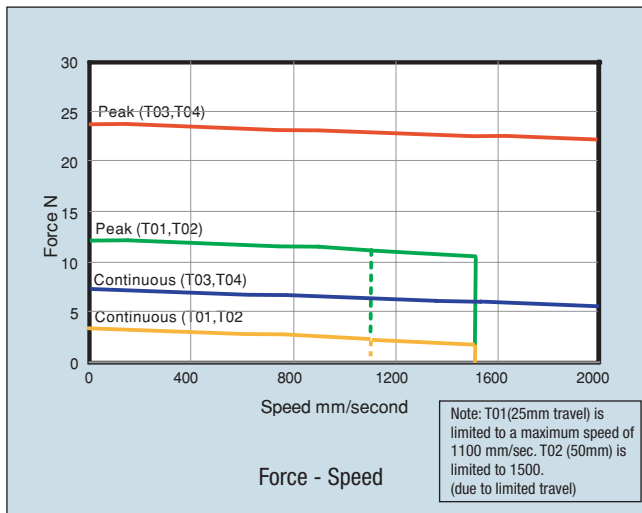
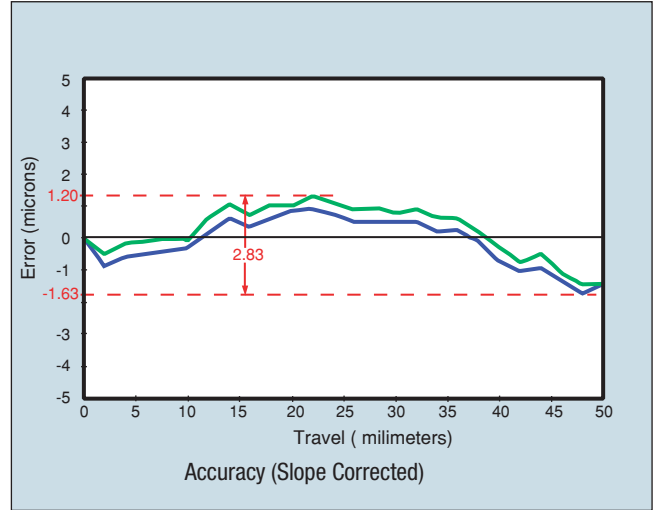



CM04 to CM07



## “Plug & Run” Cables Options

- High flex cables
- Plug-in compatibility with ViX drive
- CE compliant connectors and shielding
- CE compliant ferrite beads
- Color coded jackets and labeling

“User convenience” is high on the list of cable attributes found in the MX80. The high flex cabling and connectors are reliable, durable and offer easy hook-up for “plug and run” installation. The cables are connectorized at the stage for easy field replacement and connectorized at the opposite end for ease of installation with the Parker Vix servo drive.

E\_

**Encoder Options** A non-contact linear optical encoder provides a quadrature output and offers resolution ranging from 10 nanometer to 5 micron. On the MX80L, the encoder is internal to the stage body. There is no increase to the footprint of the unit and no additional external cabling is required.

H\_ L\_

Home and Limit Sensors Digital Hall effect home and limit sensors are completely housed within the body of the stage. An innovative design adds functionality without sacrificing geometry. Sensor triggers can be easily adjusted over the travel. The output format is an open collector type capable of sinking up to 50ma, and be set as N.O or N.C.



## Zero Cage Creep Feature

High acceleration and smooth translation are both desired attributes in a linear-motor stage. The cross roller bearing system found in the MX80 provides extremely smooth linear translation, and with an anti-cage creep design, operates very well in high acceleration

applications. This design employs a rack and pinion feature within the bearing races to eliminate bearing creep. As a result, the MX80 performs well, even at 5g acceleration.

R2 R20



## Cleanroom Option

Both Precision and Standard grade products can be prepared for cleanroom compatibility. Preparation involves material changes, element modification and cleanroom compatible lubricants. The MX80L and MX80S with the R2 option are class 10 cleanroom compatible. When applying an XY or

XYZ combination in a cleanroom environment, moving wires need to be considered - please consult a Parker application engineer. The R20 option includes both - low ESD and cleanroom preparation.

## Tooling Features



Innovative tooling features make mounting and alignment much quicker and easier.

- A hardened steel master reference surface is provided along the side of the stage to allow fixturing or other tooling elements to be precisely aligned with the actual travel path.
- Two dowel pin holes are provided on the carriage top and base for repeatable mounting of positioner or tooling.

R10 R20

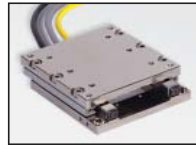

## Low ESD Coating

An optional ‘low ESD’ electroless nickel or Armoloy coating is offered for improved electrical conductivity, providing a low resistance to ground path for electric discharge.

R1

**Environmental Protection** Both precision and standard grade units have a hard coat protective finish. The precision units have a hard coat (Rc 78) satin chrome finish, and the standard units have a low lustre black anodized finish.

X2



## Z-axis Counterbalance Option

A pneumatic Z-axis counterbalance is offered to prevent a sudden load drop if power to the motor is interrupted. A controlled vertical force is applied to the stage top to negate the effect of gravity and achieve equilibrium. A precisely regulated clean air supply of 0 to 60 psi is required for operation.



## Pneumatic Accessory Package (Part Number 002-2236-01)

This accessory is offered for use with the X2 pneumatic counterbalance option. It consists of a pre-filter, a pressure regulator, a coalescing filter, and a precision regulator to precisely regulate air pressure and remove oil, water or debris down to 3 microns.

## ViX Intelligent Servo & controller

A1 A20 A21 A22 A25

The Vix servo drives are the perfect drive solution to be paired with the MX80 family. Depending on the selected version, the Vix will be configured for force, velocity, or step/direction input command signals. In addition, a complete packaged servo drive and controller is available.”



# MX80L Series

## Dimensions (millimeters)

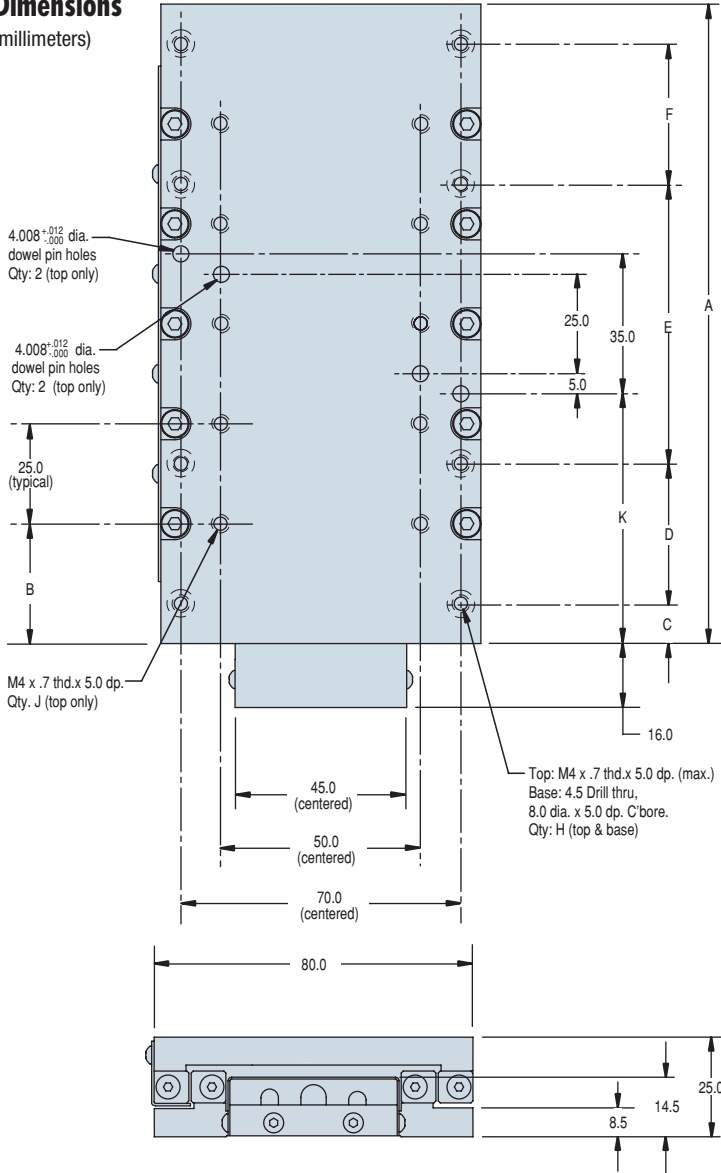

Travel	Dimensions (mm)								
	A	B	C	D	E	F	H	J	K
25	80	15	5	70	n/a	n/a	4	6	22.5
50	80	15	5	70	n/a	n/a	4	6	22.5
100	160	30	10	35	70	35	8	10	62.5
150	210	30	5	65	70	65	8	14	87.5

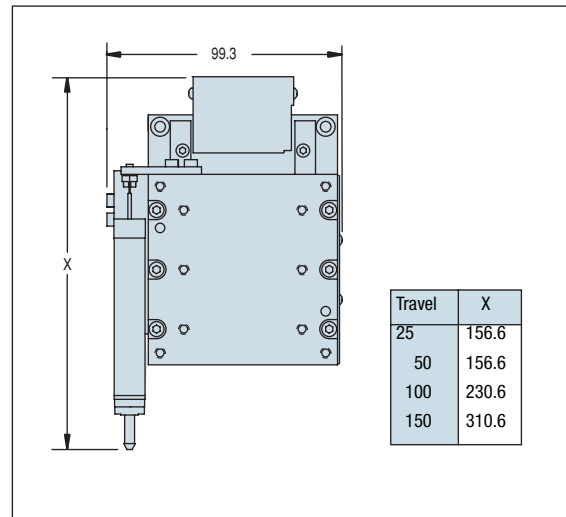
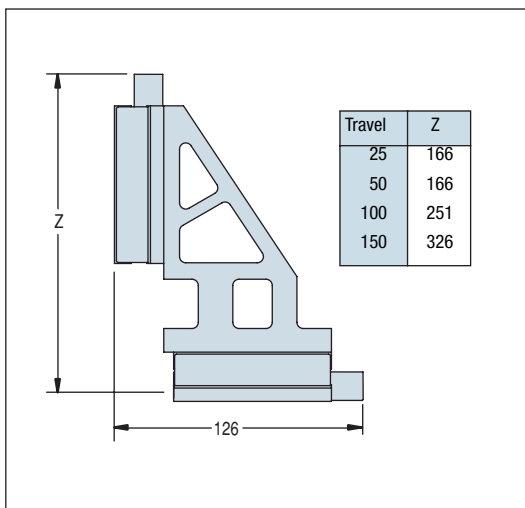

**Order Example:**

MX80L T02 M P - D11 H3 L2 CM05 Z3 E8 R1 A25 X1 S1

**Model** .....

MX80L

**Travel** 25 mm .....

T01

50 mm .....

T02

100 mm .....

T03

150 mm .....

T04

**Mounting** (metric) .....

M

**Grade** Precision .....

P

Standard .....

S

**Drive Type**

None - Free Travel .....

D1

4 Pole(25 & 50 mm travel only) .....

D11

8 Pole(100 & 150 mm travel only)

D13

**Home Sensor**

None .....

H1

N.C. Current Sinking .....

H2

N.O. Current Sinking .....

H3

**Limit Sensor**

None .....

L1

N.C. Current Sinking .....

L2

N.O. Current Sinking .....

L3

**Cable Options**

No Cables (free travel only) .....

CM03

1.0 meter high-flex cables w/ ViX connector

CM04

3.0 meter high-flex cables w/ ViX connector

CM05

1.0 meter high-flex cables w/ ViX connector  
(no limit/home cable)

CM06

3.0 meter high-flex cables w/ ViX connector  
(no limit/home cable)

CM07

**X-Y Orthogonality**

- S1 None (no X-Y configuration)
- S2 X axis unit (cables @12 o'clock)
- S3 60 arc sec. - Y-axis (3 o'clock)
- S4 60 arc sec. - Y-axis (9 o'clock)
- S5 15 arc sec. - Y-axis (3 o'clock)
- S6 15 arc sec. - Y-axis (9 o'clock)

**Other Options**

- X1 None
- X2 Z-axis Pneumatic c'balance

**Digital Drive Options**

- A1 No drive
- A20 ViX250-AH force mode
- A21 ViX250-AH velocity mode
- A22 ViX250-AH step/direction mode
- A25 ViX 250-IH drive/controller

**Environmental Options**

- R1 Standard finish
- R2 Clean room prep.
- R10 Low ESD finish
- R20 Low ESD finish and clean room prep.

**Digital Linear Encoder**

- E1 No encoder (free travel only)
- E2 1.0 micron resolution
- E3 0.5 micron resolution
- E4 0.1 micron resolution
- E5 5.0 micron resolution
- E8 .02 micron resolution (20 nanometer)
- E9 .01 micron resolution (10 nanometer)

**Z-Channel Location**

- Z1 No Z-Channel (free travel only)
- Z3 Center Position

## LX80L Linear Motor Tables

### Features

- Velocity to 3 m/sec
- Acceleration to 5 g's
- Encoder resolution to 0.1 micron
- Cleanroom compatible
- Easy multi-axis mounting
- Internal cable management



### Introduction

Miniaturization of life sciences, electronics, photonics, and fiber optic processes has driven the need for smaller and more efficient positioners. Parker's MX80, the smallest linear servomotor driven positioner in the industry, has redefined 'high-throughput automation' in the world of miniature positioners. It is loaded with high performance features for both rapid linear translation and precise positioning of smaller loads within very small work envelopes. The LX80L picks up where the MX80 leaves off, offering longer travels than the MX80 while maintaining a very small profile. Like the MX80, it is designed to meet the rigors of today's 24/7 production demands.

### High Performance in a small package

Although it has a small profile, the LX80L is large on performance and reliability. All key components are "built-in", residing within the body of the table to provide a clean looking, reliable, unobstructed package. At the heart of the LX80L is an innovative non-contact linear servo motor (patent pending). This direct drive motor has been optimized for force, speed, and acceleration to deliver outstanding performance and response. A high precision non-contact linear encoder provides submicron resolution, repeatability and accuracy with selectable resolutions ranging from 0.1 microns to 5 microns. Digital Hall effect travel limit and home sensors are conveniently designed into the unit for easy adjustment over the entire travel of the table.

Precision square rail bearings provide load support and precise linear translation, while effectively countering the problematic effects of heat, high speeds, and high acceleration. Cable management is neatly packaged inside the unit so no moving cables are visible. From the end of the unit, "hi-flex" cabling is provided for direct connection to the servo drive. This "hi-flex" cabling alleviates cable flexing concerns associated with the second or third axis in multi-axis system.

### Flexibility and Multi-Axis Compatibility

The LX80L's selection flexibility and mounting compatibility with the MX80 miniature tables enables single axis or complex multi-axis units to be configured in a straightforward manner. Parker's matching servo drives and motion controllers can be included to complete the motion system.

### Customs and Systems

For specialized applications requiring customization, Parker design engineers can easily modify LX80L tables to suit all application specific requirements. Parker has taken the mystery, difficulty and cost out of integrating linear motor tables into high throughput precision positioning applications.

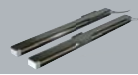

Specifications		8 Pole Single Rail	8 Pole Double Rail	16 Pole Single Rail	16 Pole Double Rail
Rated Load (kg)		3(6.5 lb.)	3(6.5 lb.)	6(13 lb.)	6(13 lb.)
Maximum Acceleration		5 g's			
Maximum Velocity (m/sec.)					
Encoder Resolution:	0.1 μm			0.3	
	0.5 μm			1.5	
	1.0 μm			3.0	
	5.0 μm			3.0	
Positional Repeatability(μm)					
Encoder Resolution:	0.1 μm	+ 2.5	+ 1.5	+ 2.5	+ 1.5
	0.5 μm	+ 2.5	+ 1.5	+ 2.5	+ 1.5
	1.0 μm	+ 3.5	+ 2.5	+ 3.5	+ 2.5
	5.0 μm	+ 10.0	+ 10.0	+ 10.0	+ 10.0
Maximum Peak Force N (lb)		19 (4.3)	19 (4.3)	36 (8.1)	36 (8.1)
Maximum Continuous Force N (lb)		4.7 (1.0)	4.7 (1.0)	10 (2.2)	10 (2.2)
Maximum Moment (Nm) .75		1.5	1.5	.75	3.0
Carriage Weight (g)		287	388	476	648

### Travel Dependent Specifications

Code	Travel		Accuracy* (μm)		Straightness & Flatness* (μm)	Length "L" (mm)	Unit Weight	
	8 pole (mm)	16 pole (mm)	0.1,0.5,1.0 resolution (μm)	5.0 resolution (μm)			8 pole (kg)	16 pole (kg)
<b>Double Rail Models</b>								
T02	150	80	8	18	9	325	1.590	1.854
T04	250	180	12	22	14	425	1.944	2.207
T06	350	280	16	26	19	525	2.300	2.563
T08	450	380	20	30	24	625	2.652	2.915
T10	550	480	23	33	29	725	3.006	3.269
T14	750	680	29	39	37	922	3.713	3.976
<b>Single Rail Models</b>								
T02	150	80	12	22	13	325	1.396	1.586
T04	250	180	16	26	18	425	1.714	1.905
T06	350	280	20	30	23	525	2.035	2.225
T08	450	380	24	34	28	625	2.352	2.543
T10	550	480	27	37	33	725	2.671	2.861
T14	750	680	33	43	41	922	3.308	3.498

\* Accuracy stated is at 20 degrees C, utilizing slope correction factor provided.

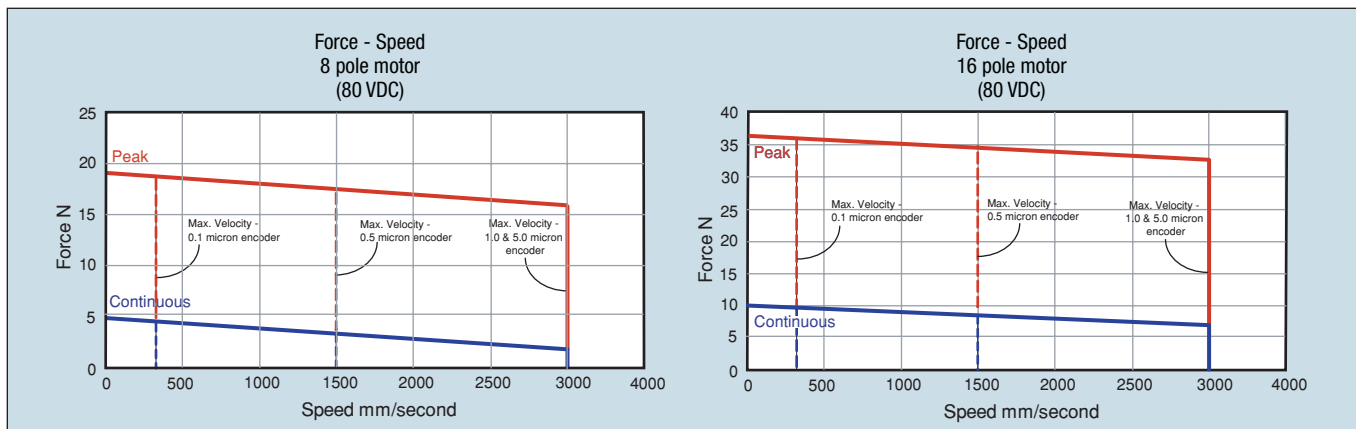

**Cable Management**

**“Plug & Run” Cables**

“User Friendly” and “robust” were the goals of the cabling design. All cables are ‘hi-flex’ for durability and are fully shielded. The cables are labeled for quick identification and have connectors at critical locations to simplify use. The drive end terminations are ViX series servo drive compatible and have CE compliant connectors including a ferrite bead to improve EMI immunity.



**Internal Cable Management**

The LX80’s pre-engineered internal cable management offers several benefits. It preserves the LX80’s narrow footprint by not requiring additional space for cable management. It allows the table to be mounted in any orientation without a need to re-engineer the cable management. The innovative design is field serviceable and can be maintained without a trip back to the factory. It is designed for and fully tested to last over 20 million cycles. And best of all, it is already done for you!

**Cable Options**

From the end of the LX80L, high flex extension cables are included for connection to the servo drive and control. They are offered in 1m and 3m lengths and are connectorized at both ends for easy installation or removal. The servo drive end is connectorized for Parker’s ViX series servo drives.

The extension cables egress from the table at a right angle to minimize the overall length of the system. In the standard configuration the cable egress to the left, however, the design is flexible and allows them to egress to the right if desired.

**Multi-Axis Cable Management**

When building multi-axis systems, flexible cable management for the moving axes should be considered. Parker offers pre-engineered cable management for MX80s and LX80s used as the Y-axis. Contact Parker when putting multi-axis systems together to take advantage of these pre-engineered solutions.

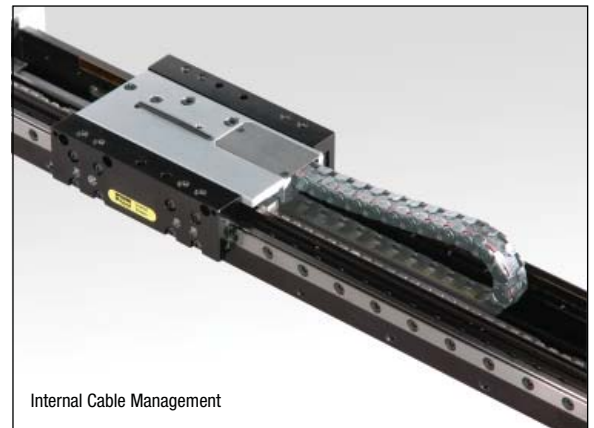

Internal Cable Management



Convenient connectors for ViX drives

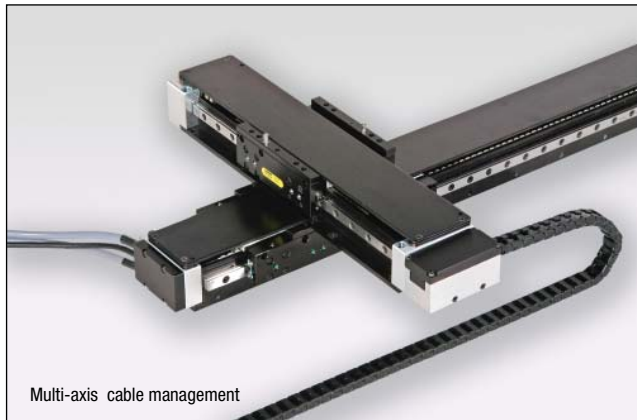

Multi-axis cable management

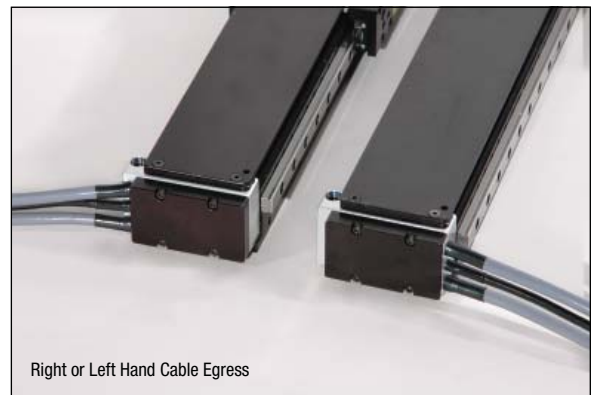

Right or Left Hand Cable Egress

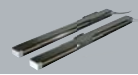

## Features

**Single or double row bearings** - Precision linear bearings support the carriage, motor, and payload. Sized to provide virtually unlimited life, the bearings provide stable and accurate linear motion while maintaining high rigidity even under combined or fluctuating loads. Unique in the



LX80L's design are single and double linear bearing rail options. The double rail design consists of two linear rails spaced apart with a total of four bearing trucks. This version offers the best load capacity, straightness/flatness, and stability. For applications requiring

minimal load capacity and precision, a single rail version is offered with a single linear rail and two bearing trucks. This version reduces cost and further reduces the width to 63mm. The single rail version is also useful when building gantry systems where stability is achieved through use of a second axis or idler rail.

**Tooling Features** - Standard dowel pin locating holes facilitate



repeatable mounting of a table and payloads. Two dowel holes in the LX80L base enable simple, repeatable mounting of the table into a machine. Similarly, two dowel holes in the carriage enable simple, repeatable mounting of a fixture or payload onto the LX80L.

**Mounting Variations** - All versions of the LX80 can be mounted flat to



a surface using 4mm cap screws. The single rail version offers an additional mounting option where the table can be edge mounted. This allows further reduction of axis width to 45mm for applications where space is very limited.

**Orthogonality** - In any multi-axis positioning system, the perpendicular alignment of the axes must be clearly specified. "Degree of orthogonality" defines the perpendicular alignment of axis one to another. The LX80L is offered with two choices for orthogonality. As standard, (S3 or S4 designators) perpendicularity is held to within 60 arc seconds. For more exacting applications the LX80L can be optioned for 15 arc seconds orthogonality (S5 or S6 designators).

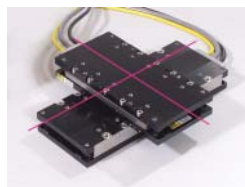

**Cleanroom Option** - LX80 tables can be prepared for cleanroom compatibility. Preparation involves material changes, element modification and cleanroom compatible lubricants. The LX80L with the R2 option is class 100 cleanroom compatible. When applying an XY or XYZ combination in a cleanroom environment, moving wires need to be considered - please consult a Parker application engineer.



**Home and Limit Sensors** - Digital Hall effect home and limit sensors



are completely housed within the body of the motor driven table. An innovative design adds functionality without sacrificing geometry. Sensor triggers can be easily adjusted over the travel. The output format is an open collector type capable of sinking up to 50ma.

**E - Encoder Options** - A non-contact linear optical encoder provides a quadrature output and offers resolution ranging from 0.1 micron to 5 micron. On the LX80L, the encoder is internal to the table body. There is no increase to the footprint of the unit and no additional external cabling is required.

**Z-axis Bracket**- Lightweight aluminum Z-brackets are available for easy construction of vertical axis combinations. These include brackets for mounting both the MX80L and MX80S tables as verticals.



**Idler Rail**- For gantry or cartesian configurations, an idler rail is available to provide greater system stability. Contact a Parker application engineer for detail on adding this to your system.



Dimensions (mm)

Two Rail - 8 Pole Model

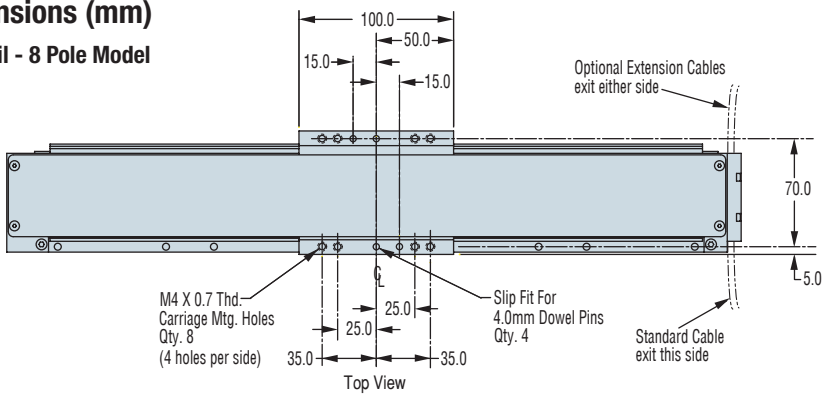

Code	Travel		Dimensions (mm)				
	8 pole	16pole	A	B	C	D	E
T02	150	80	325	146	-	-	6
T04	250	180	425	196	1	70	8
T06	350	280	525	246	1	70	8
T08	450	380	625	296	2	140	10
T10	550	480	725	346	3	210	12
T14	750	680	925	396	4	280	14

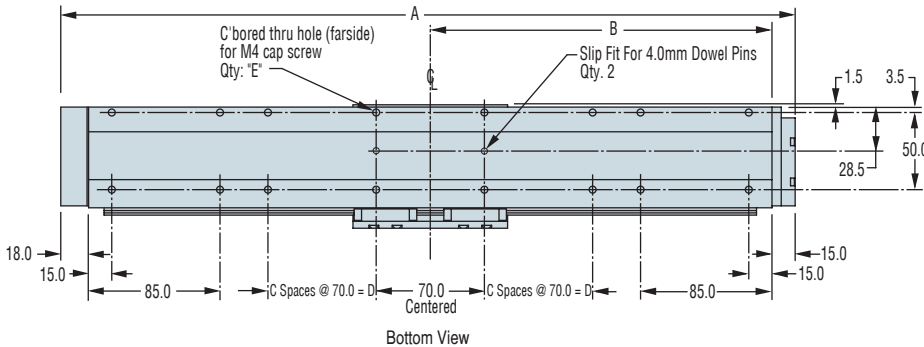
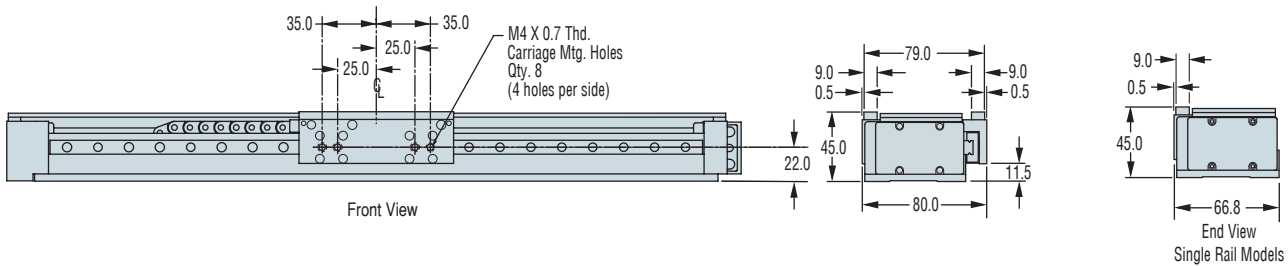

Note:  
For edge mounting dimensions go to parkermotion.com - CAD Drawing files

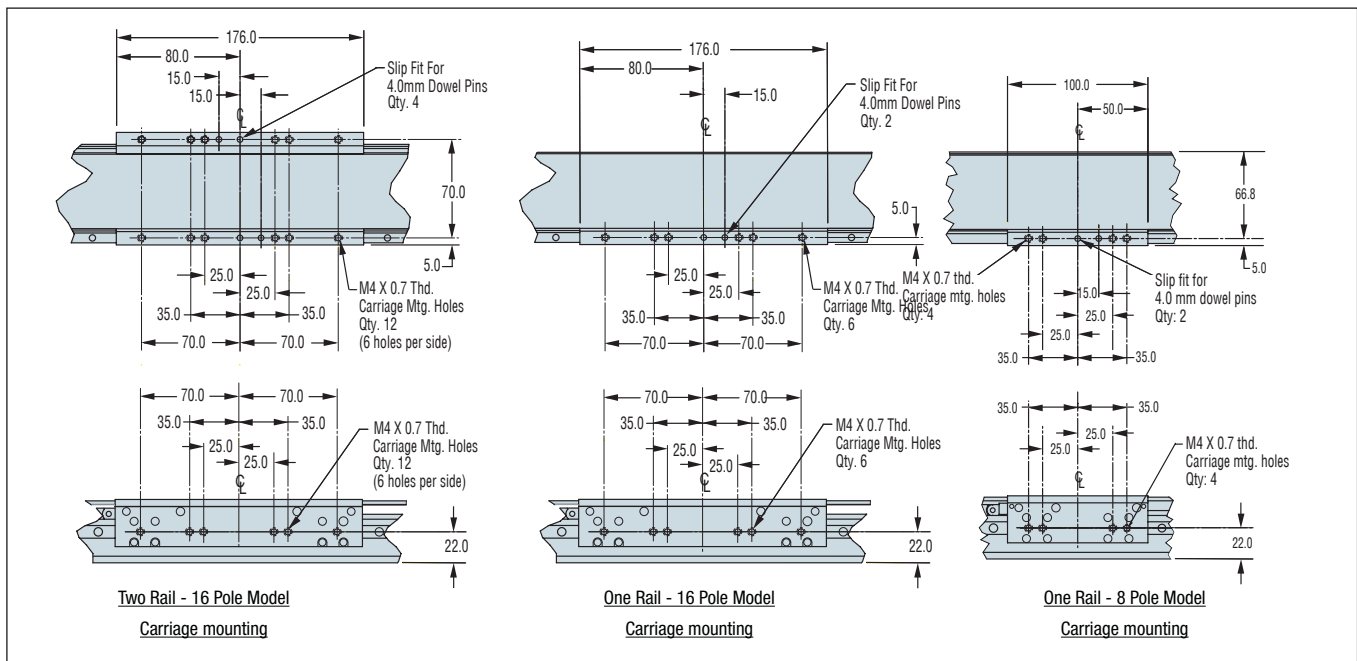

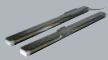

Order Example:

LX80L T04 M P D D13 CM05 Z3 E3 R1 A25 X1 S1

Model .....

LX80L

Travel

8 pole 16 pole (motor)

150mm..... 80mm.....

T02

250mm.....180mm.....

T04

350mm.....280mm.....

T06

450 mm.....380mm.....

T08

550 mm.....480mm .....

T10

750 mm.....680mm .....

T14

Mounting...(metric).....

M

Grade.....(precision)....

P

Bearings

Double Rail .....

D

Single Rail .....

S

Drive Type

None - 8 pole carriage .....

D3

None - 16 pole carriage .....

D7

8 pole linear motor\* .....

D13

16 pole linear motor\* .....

D17

\* includes home or limit sensors

Cable Options

No Cables (free travel) .....

CM03

1.0 meter high-flex cables w/ ViX connector .....

CM04

3.0 meter high-flex cables w/ ViX connector .....

CM05

X-Y Orthogonality

S1 None (no X-Y configuration)

S2 X axis unit (cables @12 o'clock)

S3 60 arc sec. - Y-axis (3 o'clock)

S4 60 arc sec. - Y-axis (9 o'clock)

S5 15 arc sec. - Y-axis (3 o'clock)

S6 5 arc sec. - Y-axis (9 o'clock)

Other Options

X1 None

Digital Drive Options

A1 No drive

A20 ViX250-AH force mode

A21 ViX250-AH velocity mode

A22 ViX250-AH step/direction mode

A25 ViX 250-IH drive/controller

Environmental Options

R1 Standard finish

R2 Cleanroom prep.

Digital Linear Encoder

E1 No encoder (free travel only)

E2 1.0 micron resolution

E4 0.1 micron resolution

E5 5.0 micron resolution

E3 0.5 micron resolution

Z-Channel Location

Z1 No Z-Channel (free travel only)

Z2 Positive end position

## Motion Control Technologies from Parker

Parker provides “perfect fit” electromechanical solutions for high-precision positioning and high-speed automation. These systems are offered at selectable levels of integration ranging from motor components... to basic single axis mechanical tables... to complete electromechanical systems and robots including motors, drives, controls, and machine interface.



### ACR Motion Controller

- ETHERNET Powerlink high speed digital communications
- Interpolation of up to 8 axes of servo or stepper control
- Advanced multitasking
- 10/100 Base T Ethernet and USB communications
- Absolute Encoder support via SSI

- Linear motor “gantry lock” feature to provide accurate skew control for gantry roots.

### EPX InteractX Powerstations

- InteractX Windows HMI with unlimited tags and 60+ drivers
- Hard drive or CompactFlash storage
- Ethernet, USB, RS232/422/485 communications
- Breakthrough graphic technology
- Panel tool library for easy screen development (no scripting)



### Aries servo amplifiers



- ETHERNET Powerlink high speed digital communications
- Fully digital, sinusoidally commutated brushless servo drive
- 7 power levels available up to 16 ARMS continuous current, or 3000 W
- Plug in and Spin - no set up required with Parker smart encoder
- Supports incremental, absolute and resolver feedback

## Engineered Precision Motion Systems

OEMs and manufacturers look to Parker because they know our extensive motion system design experience, systematic project management process, and global infrastructure ensure their needs are met.

Through years of motion system design and manufacturing, we have developed a collaborative development cycle and systematic six-step project management process that leads the motion industry.

Since our technology enables our customer’s technology, we build strategic partnerships and strictly maintain confidentiality with our customers.

Parker’s Engineered Solutions incorporate air-bearing, linear motor, and pneumatic technology with composite or conventional materials to create a total solution.

### Collaborative Development Cycle

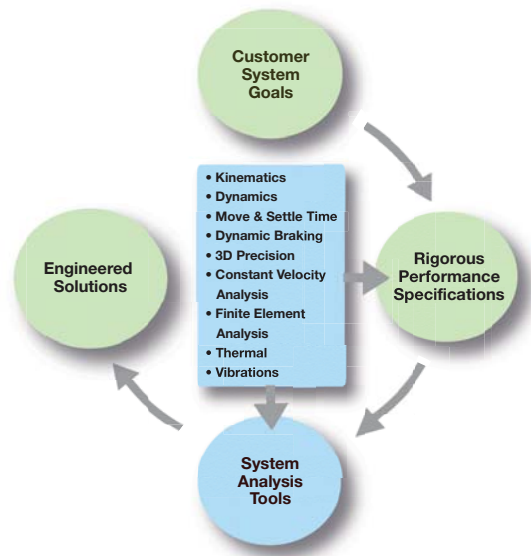

### Custom Engineered systems for demanding industries

- Flat Panel
- Semiconductor
- Life Sciences and Biomedical
- Aerospace
- And other industries with rigorous performance specifications



### **WARNING - USER RESPONSIBILITY**

**FAILURE OR IMPROPER SELECTION OR IMPROPER USE OF THE PRODUCTS DESCRIBED HEREIN OR RELATED ITEMS CAN CAUSE DEATH, PERSONAL INJURY AND PROPERTY DAMAGE.**

This document and other information from Parker-Hannifin Corporation, its subsidiaries and authorized distributors provide product or system options for further investigation by users having technical expertise.

The user, through its own analysis and testing, is solely responsible for making the final selection of the system and components and assuring that all performance, endurance, maintenance, safety and warning requirements of the application are met. The user must analyze all aspects of the application, follow applicable industry standards, and follow the information concerning the product in the current product catalog and in any other materials provided from Parker or its subsidiaries or authorized distributors.

To the extent that Parker or its subsidiaries or authorized distributors provide component or system options based upon data or specifications provided by the user, the user is responsible for determining that such data and specifications are suitable and sufficient for all applications and reasonably foreseeable uses of the components or systems.

### **OFFER OF SALE**

The items described in this document are hereby offered for sale by Parker-Hannifin Corporation, its subsidiaries or its authorized distributor. This offer and its acceptance are governed by the provisions stated in the detailed "Offer of Sale" found on the next page of this publication.

## Offer of Sale

The items described in this document and other documents or descriptions provided by Parker Hannifin Corporation, its subsidiaries and its authorized distributors are hereby offered for sale at prices to be established by Parker Hannifin Corporation, its subsidiaries and its authorized distributors. This offer and its acceptance by any customer ("Buyer") shall be governed by all of the following Terms and Conditions. Buyer's order for any such item, when communicated to Parker Hannifin Corporation, its subsidiary or an authorized distributor ("Seller") verbally or in writing, shall constitute acceptance of this offer.

**1. Terms and Conditions of Sale:** All descriptions, quotations, proposals, offers, acknowledgments, acceptances and sales of Seller's products are subject to and shall be governed exclusively by the terms and conditions stated herein. Buyer's acceptance of any offer to sell is limited to these terms and conditions. Any terms or conditions in addition to, or inconsistent with those stated herein, proposed by Buyer in any acceptance of an offer by Seller, are hereby objected to. No such additional, different or inconsistent terms and conditions shall become part of the contract between Buyer and Seller unless expressly accepted in writing by Seller. Seller's acceptance of any offer to purchase by Buyer is expressly conditional upon Buyer's assent to all the terms and conditions stated herein, including any terms in addition to, or inconsistent with those contained in Buyer's offer. Acceptance of Seller's products shall in all events constitute such assent.

**2. Payment:** Payment shall be made by Buyer net 30 days from the date of delivery of the items purchased hereunder. Amounts not timely paid shall bear interest at the maximum rate permitted by law for each month or portion thereof that the Buyer is late in making payment. Any claims by Buyer for omissions or shortages in a shipment shall be waived unless Seller receives notice thereof within 30 days after Buyer's receipt of the shipment.

**3. Delivery:** Unless otherwise provided on the face hereof, delivery shall be made F.O.B. Seller's plant. Regardless of the method of delivery, however, risk of loss shall pass to Buyer upon Seller's delivery to a carrier. Any delivery dates shown are approximate only and Seller shall have no liability for any delays in delivery.

**4. Warranty:** Seller warrants that the items sold hereunder shall be free from defects in material or workmanship for a period of 24 months for Linear motors and 12 months for Positioning systems from date of shipment from Parker Hannifin Corporation. **THIS WARRANTY COMPRISES THE SOLE AND ENTIRE WARRANTY PERTAINING TO ITEMS PROVIDED HEREUNDER. SELLER MAKES NO OTHER WARRANTY, GUARANTEE, OR REPRESENTATION OF ANY KIND WHATSOEVER. ALL OTHER WARRANTIES, INCLUDING BUT NOT LIMITED TO, MERCHANTABILITY AND FITNESS FOR PURPOSE, WHETHER EXPRESS, IMPLIED, OR ARISING BY OPERATION OF LAW, TRADE USAGE, OR COURSE OF DEALING ARE HEREBY DISCLAIMED.**

**NOT WITHSTANDING THE FOREGOING, THERE ARE NO WARRANTIES WHATSOEVER ON ITEMS BUILT OR ACQUIRED WHOLLY OR PARTIALLY, TO BUYER'S DESIGNS OR SPECIFICATIONS.**

**5. Limitation of Remedy:** SELLER'S LIABILITY ARISING FROM OR IN ANY WAY CONNECTED WITH THE ITEMS SOLD OR THIS CONTRACT SHALL BE LIMITED EXCLUSIVELY TO REPAIR OR REPLACEMENT OF THE ITEMS SOLD OR REFUND OF THE PURCHASE PRICE PAID BY BUYER, AT SELLER'S SOLE OPTION. IN NO EVENT SHALL SELLER BE LIABLE FOR ANY INCIDENTAL, CONSEQUENTIAL OR SPECIAL DAMAGES OF ANY KIND OR NATURE WHATSOEVER, INCLUDING BUT NOT LIMITED TO LOST PROFITS ARISING FROM OR IN ANY WAY CONNECTED WITH THIS AGREEMENT OR ITEMS SOLD HEREUNDER, WHETHER ALLEGED TO ARISE FROM BREACH OF CONTRACT, EXPRESS OR IMPLIED WARRANTY, OR IN TORT, INCLUDING WITHOUT LIMITATION, NEGLIGENCE, FAILURE TO WARN OR STRICT LIABILITY.

**6. Changes, Reschedules and Cancellations:** Buyers may request to modify the designs or specifications for the items sold hereunder as well as the quantities and delivery dates thereof, or may request to cancel all or part of this order, however, no such requested modification or cancellation shall become part of the contract between Buyer and Seller unless accepted by Seller in a written amendment to this Agreement. Acceptance of any such requested modification of cancellation shall be at Seller's discretion, and shall be upon such terms and conditions as Seller may require.

**7. Special Tooling:** A tooling charge may be imposed for any special tooling, including without limitation, dies, fixtures, molds and patterns, acquired to manufacture items sold pursuant to this contract. Such special tooling shall be and remain Seller's property notwithstanding payment of any charges by Buyer. In no event will Buyer acquire any interest in apparatus belonging to Seller which is utilized in the manufacture of the items sold hereunder, even if such apparatus has been specially converted or adapted for such manufacture and notwithstanding any charges paid by Buyer. Unless otherwise agreed, Seller shall have the right to alter, discard or otherwise dispose of any special tooling or other property in its sole discretion at any time.

**8. Buyer's Property:** Any designs, tools, patterns, materials, drawings, confidential information or equipment furnished by Buyer, or any other items which become Buyer's property, may be considered obsolete and may be destroyed by Seller after two (2) consecutive years have elapsed without Buyer placing an order for the items which are manufactured using such property. Seller shall not be responsible for any loss or damage to such property while it is in Seller's possession or control.

**9. Taxes:** Unless otherwise indicated on the face hereof, all prices and charges are exclusive of excise, sales, use, property, occupational or like taxes which may be imposed by any taxing authority upon the manufacture, sale or delivery of the items sold hereunder. If any such taxes must be paid by Seller or if Seller is liable for the collection of such tax, the amount thereof shall be in addition to the amounts for the items sold. Buyer agrees to pay all such taxes or to reimburse Seller therefore upon receipt of its invoice. If Buyer claims exemption from any sales, use or other tax imposed by any taxing authority, Buyer shall save Seller harmless from and against any such tax, together with any interest or penalties thereon which may be assessed if the items are held to be taxable.

**10. Indemnity For Infringement of Intellectual Property Rights:** Seller shall have no liability for infringement of any patents, trademarks, copyrights, trade dress, trade secrets or similar rights except as provided in this Part 10. Seller will defend and indemnify Buyer against allegations of infringement of U.S. patents, U.S. trademarks, copyrights, trade dress and trade secrets (hereinafter 'Intellectual Property Rights'). Seller will defend at its expense and will pay the cost of any settlement or damages awarded in an action brought against Buyer based on an allegation that an item sold pursuant to this contract infringes the Intellectual Property Rights of a third party. Seller's obligation to defend and indemnify Buyer is contingent on Buyer notifying Seller within ten (10) days after Buyer becomes aware of such allegations of infringement, and Seller having sole control over the defense of any allegations or actions including all negotiations for settlement or compromise. If an item sold hereunder is subject to a claim that it infringes the Intellectual Property Rights of a third party, Seller may, at its sole expense and option, procure for Buyer the right to continue using said item, replace or modify said item so as to make it noninfringing, or offer to accept return of said item and return the purchase price less a reasonable allowance for depreciation. Notwithstanding the foregoing, Seller shall have no liability for claims of infringement based on information provided by Buyer, or directed to items delivered hereunder for which the designs are specified in whole or part by Buyer, or infringements resulting from the modification, combination or use in a system of any item sold hereunder. The foregoing provisions of this Part 10 shall constitute Seller's sole and exclusive liability and Buyer's sole and exclusive remedy for infringement of Intellectual Property Right.

If a claim is based on information provided by Buyer or if the design for an item delivered hereunder is specified in whole or in part by Buyer, Buyer shall defend and indemnify Seller for all costs, expenses or judgements resulting from any claim that such item infringes any patent, trademark, copyright, trade dress, trade secret or any similar right.

**11. Force Majeure:** Seller does not assume the risk of and shall not be liable for delay or failure to perform any of Seller's obligations by reason of circumstances beyond the reasonable control of Seller (hereinafter 'Events of Force Majeure'). Events of Force Majeure shall include without limitation, accidents, acts of God, strikes or labor disputes, acts, laws, rules or regulations of any government or government agency, fires, floods, delays or failures in delivery of carriers or suppliers, shortages of materials and any other cause beyond Seller's control.

**12. Entire Agreement/Governing Law:** The terms and conditions set forth herein, together with any amendments, modifications and any different terms or conditions expressly accepted by Seller in writing, shall constitute the entire Agreement concerning the items sold, and there are no oral or other representations or agreements which pertain thereto. This Agreement shall be governed in all respects by the law of the State of Ohio. No actions arising out of the sale of the items sold hereunder of this Agreement may be brought by either party more than two (2) years after the cause of action accrues.

# Extensive Automation Solutions

## HMI and Controllers



Superior integration and support for machine control as well as HMI hardware and software.

[www.parkermotion.com/em/hmicont](http://www.parkermotion.com/em/hmicont)

## Electric Actuators



Screw, belt-driven, and linear motor actuators for the complete range of industrial applications, offering precise motion and flexibility.

[www.parkermotion.com/em/linear](http://www.parkermotion.com/em/linear)

## Motors and Drives



Parker's family of innovative servo/stepper motors and drives continues to expand to meet the challenges of new technologies.

[www.parkermotion.com/em/motordrive](http://www.parkermotion.com/em/motordrive)

## Linear Actuators



Aluminum and steel pneumatic cylinders, guided cylinders, rodless cylinders, and short stroke thrusters from the industry leader.

[www.parkermotion.com/pneu/linear](http://www.parkermotion.com/pneu/linear)

## Rotary Actuators



Industry leader in the design and manufacture of pneumatic rack and pinion, and vane-style rotary actuators.

[www.parker.com/pneu/rotary](http://www.parker.com/pneu/rotary)

## Vacuum Products and Sensors



Vacuum solutions include a broad range of generators (integrated/inline), cups, and pressure sensors.

[www.parker.com/pneu/vacsen](http://www.parker.com/pneu/vacsen)

## Grippers



Parallel, angular, and three jaw grippers are available in over 1,000 configurations.

[www.parker.com/pneu/gripper](http://www.parker.com/pneu/gripper)

## Airline Accessories



Airline accessories include silencers, flow controls, and mufflers to round out Parker's pneumatic solution.

[www.parker.com/pneu/access](http://www.parker.com/pneu/access)

## Air Control Valves



Valve technology that meets the most demanding requirements in any industrial application.

[www.parker.com/pneu/valve](http://www.parker.com/pneu/valve)

## Air Preparation



Parker, the industry leader in air preparation, offers a complete line of products to ensure clean, dry, oil-free air.

[www.parker.com/pneu/airprep](http://www.parker.com/pneu/airprep)

## Connectors and Tubing



The most complete line of fluid connectors worldwide will meet virtually any automation application.

[www.parker.com/pneu/fc](http://www.parker.com/pneu/fc)

## Parker IPS Structural Automation



More than 150 metric and inch profiles, integral motion components, and accessories for unlimited and flexible configurations. Pre-machined kits or complete assemblies.

[www.parker.com/ips](http://www.parker.com/ips)



New Parker Trilogy catalog. Call for your comprehensive guide today. 800-358-9070 96-028778-01/US

Parker also has product ranges available for the Precision Automation, Industrial Automation and Pneumatic markets, each paired with an interactive CD. Call 800-CPARKER.

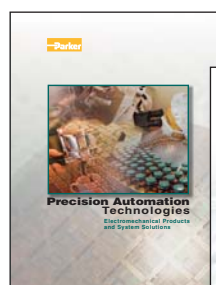

Bulletin  
AU01-5000/US

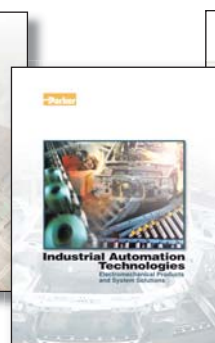

Bulletin  
AU01-7500/US

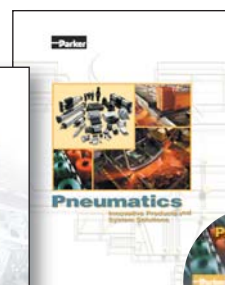

Bulletin  
AU01-1000/US

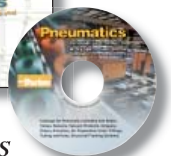

# EM Sales Offices

## Australia

**Parker Hannifin (Australia)**  
Pty Limited  
9 Carrington Road  
Castle Hill NSW 2154  
Australia  
Tel: +61 (0) 2 9842 5160  
Fax: +61 (0) 2 9634 3749

## Brazil

**Parker Hannifin Ind. Com Ltda.**  
Av. Lucas Nogueira Garcez 2181  
Esperança  
12325-900 Jacareí, SP  
Tel: 12 3954 5100  
Fax: 12 3954 5262  
automation.brazil@parker.com

## China

**Parker Hannifin Motion & Control  
(Shanghai) Co., Ltd**  
280 Yunqiao Rd, Jin Qiao Export  
Processing Zone  
Shanghai 201206, China  
Tel: (86-21) 50312525  
Fax: (86-21) 64459717

## France

**Parker SSD Parvex**  
8 avenue du Lac  
B.P. 249  
F-21007 Dijon Cedex  
Tel: +33 (0) 3 80 42 41 40  
Fax: +33 (0) 3 80 42 41 23

## India

**Parker Hannifin India Pvt. Ltd.**  
EL-26, TTC. Industrial Area.  
Mahape, Navi-Mumbai.-400 709.  
Tel: 0091 22 65137081 85, 65137050-03  
Fax: 0091 22 27686841, 27686618

## Italy

**Parker Hannifin SpA  
(SSD Drives Division)**  
Via Gran Sasso, 7  
20030 Lentate sul Seveso -  
MI - Italy  
Tel: +39 0362 557308  
Fax: +39 0362 557312

## Korea

**Parker Hannifin Korea**  
6th Floor Daehwa Building  
169 Samsung-dong Kangnam-gu  
Seoul 135-882, South Korea  
Tel: +82 2 559 0400  
Fax: +82 2 556 8187

## Scotland and Northern Ireland

Unit 59  
Stirling Enterprise Park  
Player Road  
Stirling FK7 7RP  
Tel: +44 (0) 1786 471674  
Fax: +44 (0) 1786 451095

## Singapore

**Parker Hannifin  
Singapore Pte Ltd**  
11, Fourth ChinBee Road  
Singapore 619702  
Tel: (65) 6887 6300  
Fax: (65) 6265 5125/6261 4929

## Singapore Pte Ltd (Branch Office)

Lot 558A, Jalan Subang 3  
Off Persiaran Subang  
Sungai Penaga Industrial Park  
47610 Subang Jaya Malaysia  
Tel: (60) 03 5638 1476  
Fax: (60) 03 5638 1527

## Taiwan

**Parker Hannifin Taiwan Co., Ltd**  
No. 40, Wuchiuan 3rd Road  
Wuku Industrial Park  
Taipei County, Taiwan 248  
ROC  
Tel: 886 2 2298 8987  
Fax: 886 2 2298 8982

## Thailand

**Parker Hannifin (Thailand) Co., Ltd.**  
1023, 3rd Floor, TPS Building,  
Pattanakarn Road,  
Suanluang, Bangkok 10250  
Thailand  
Tel: (66) 02717 8140  
Fax: (66) 02717 8148

## UK

**Parker Hannifin (Main Office)**  
New Courtwick Lane  
Littlehampton  
West Sussex BN17 7RZ  
United Kingdom  
Tel: +44 (0) 1903 737000  
Fax: +44 (0) 1903 737100

## USA

**Parker Hannifin  
Electromechanical Automation Division  
Main Office/Compumotor**  
5500 Business Park Drive  
Rohnert Park, CA 94928 USA  
Tel: 707-584-7558  
800-358-9070  
Fax: 707-584-8015  
Email: emn\_support@parker.com

**Parker Hannifin  
Electromechanical Automation  
Division/CTC**  
50 West TechneCenter Dr.  
Milford, OH 45150  
Tel: 513-831-2340  
800-233-3329  
Fax: 513-831-5042  
Email: emn\_moreinfo\_ctc@parker.com

**Parker Hannifin  
Electromechanical Automation  
Division/Bayside**  
27 Seaview Boulevard  
Port Washington, NY 11050  
Tel: 516-484-5353  
800-305-4555  
Fax: 516-629-8000  
Email: emn\_support\_bayside@parker.com

**Parker Hannifin  
Electromechanical Automation  
Division/Daedal**  
1140 Sandy Hill Road  
Irwin, PA 15642  
Tel: 724-861-8200  
800-245-6903  
Fax: 724-861-3330  
Email: ddlicat@parker.com

## Parker Hannifin Corporation

Electromechanical Automation  
5500 Business Park Drive

Rohnert Park, CA 94928

Phone: 800.358.9068

Fax: 707-584-8015

Web site: [www.parkermotion.com](http://www.parkermotion.com)

[www.trilogysystems.com](http://www.trilogysystems.com)

Catalog 96-028778-01  
Printed in U.S.A

