

Grizzly *Industrial, Inc.*®

MODEL G1005Z MILL/DRILL OWNER'S MANUAL



COPYRIGHT © JUNE, 2006 BY GRIZZLY INDUSTRIAL, INC.
**WARNING: NO PORTION OF THIS MANUAL MAY BE REPRODUCED IN ANY SHAPE
OR FORM WITHOUT THE WRITTEN APPROVAL OF GRIZZLY INDUSTRIAL, INC.**
#JK8304 PRINTED IN TAIWAN



WARNING!

This manual provides critical safety instructions on the proper setup, operation, maintenance and service of this machine/equipment.

Failure to read, understand and follow the instructions given in this manual may result in serious personal injury, including amputation, electrocution or death.

The owner of this machine/equipment is solely responsible for its safe use. This responsibility includes but is not limited to proper installation in a safe environment, personnel training and usage authorization, proper inspection and maintenance, manual availability and comprehension, application of safety devices, blade/cutter integrity, and the usage of personal protective equipment.

The manufacturer will not be held liable for injury or property damage from negligence, improper training, machine modifications or misuse.



WARNING!

Some dust created by power sanding, sawing, grinding, drilling, and other construction activities contains chemicals known to the State of California to cause cancer, birth defects or other reproductive harm. Some examples of these chemicals are:

- **Lead from lead-based paints.**
- **Crystalline silica from bricks, cement and other masonry products.**
- **Arsenic and chromium from chemically-treated lumber.**

Your risk from these exposures varies, depending on how often you do this type of work. To reduce your exposure to these chemicals: Work in a well ventilated area, and work with approved safety equipment, such as those dust masks that are specially designed to filter out microscopic particles.

Table of Contents

- INTRODUCTION..... 2**
 - Foreword 2
 - Contact Info..... 2
 - Machine Data Sheet..... 3
 - Identification 5
- SECTION 1: SAFETY 6**
 - Additional Safety for Mill/Drills..... 8
- SECTION 2: CIRCUIT REQUIREMENTS 9**
 - 110/220V Operation 9
 - Grounding..... 10
 - Extension Cords..... 10
- SECTION 3: SET UP 11**
 - Set Up Safety 11
 - Items Needed for Set Up 11
 - Unpacking 11
 - Inventory..... 12
 - Clean Up 13
 - Site Considerations 13
 - Mounting..... 14
 - Assembly..... 14
 - Test Run..... 15
- SECTION 4: OPERATIONS 16**
 - Operation Safety 16
 - Installing/Removing Tooling 16
 - Table 18
 - Graduated Dials 19
 - Backlash..... 19
 - Micro-Downfeed Handwheel 19
 - Quill Lock 20
 - Depth Stop 20
 - Choosing Milling Speeds..... 21
 - Choosing Drilling Speeds..... 21
 - Changing Speeds..... 23
 - Drilling Guidelines 24
- SECTION 5: ACCESSORIES 25**
- SECTION 6: MAINTENANCE 26**
 - Schedule 26
 - Cleaning 26
 - Unpainted Cast Iron 26
 - Lubrication..... 26
- SECTION 7: SERVICE 27**
 - Troubleshooting..... 27
 - Depth Stop Calibration 30
 - Feed Shaft Spring Tension 30
 - Electrical Components 32
 - Wiring Diagram 33
 - G1005Z Main Assembly Breakdown..... 34
 - G1005Z Main Assembly Parts List..... 35
 - G1005Z Table Breakdown 36
 - G1005Z Table and Labels Parts List 37
- WARRANTY AND RETURNS 38**

INTRODUCTION

Foreword

We are proud to offer the Model G1005Z Mill/Drill. This machine is part of a growing Grizzly family of fine woodworking and metalworking machinery. When used according to the guidelines set forth in this manual, you can expect years of trouble-free, enjoyable operation and proof of Grizzly's commitment to customer satisfaction.

We are pleased to provide this manual with the Model G1005Z. It was written to guide you through assembly, review safety considerations, and cover general operating procedures. It represents our effort to produce the best documentation possible.

The specifications, drawings, and photographs illustrated in this manual represent the Model G1005Z as supplied when the manual was prepared. However, owing to Grizzly's policy of continuous improvement, changes may be made at any time with no obligation on the part of Grizzly. For your convenience, we always keep current Grizzly manuals available on our website at **www.grizzly.com**. Any updates to your machine will be reflected in these manuals as soon as they are complete. Visit our site often to check for the latest updates to this manual!

Contact Info

If you have any comments regarding this manual, please write to us at the address below:

Grizzly Industrial, Inc.
c/o Technical Documentation Manager
P.O. Box 2069
Bellingham, WA 98227-2069

We stand behind our machines. If you have any service questions or parts requests, please call or write us at the location listed below.

Grizzly Industrial, Inc.
1203 Lycoming Mall Circle
Muncy, PA 17756
Phone: (570) 546-9663
Fax: (800) 438-5901
E-Mail: techsupport@grizzly.com
Web Site: <http://www.grizzly.com>





MACHINE DATA SHEET

Customer Service #: (570) 546-9663 · To Order Call: (800) 523-4777 · Fax #: (800) 438-5901

MODEL G1005Z MILL/DRILL MILLING MACHINE #25

Product Dimensions:

Weight..... 374 lbs.
 Length/Width/Height..... 36-1/2 x 34-1/2 x 40 in.
 Foot Print (Length/Width)..... 20-1/2 x 13 in.

Shipping Dimensions:

Type..... Wood Crate
 Content..... Machine
 Weight..... 440 lbs.
 Length/Width/Height..... 28" x 29" x 42"

Electrical:

Switch..... Push Button
 Switch Voltage..... 110V
 Cord Length..... 6 ft.
 Cord Gauge..... 14 gauge
 Recommended Breaker Size..... 20 amp
 Plug..... Yes

Motors:

Main

Type..... TEFC Capacitor Start Induction
 Horsepower..... 1 HP
 Voltage..... 110/220V
 Prewired..... 110V
 Phase..... Single
 Amps..... 12/6A
 Speed..... 1725 RPM
 Cycle..... 60 Hz
 Number Of Speeds..... 1
 Power Transfer Belt Drive
 Bearings..... Shielded, Permanently Lubricated

Main Specifications:

Operation Info

Spindle Travel..... 3-5/8 in.
 Swing..... 16 in.
 Longitudinal Table Travel..... 15" in.
 Cross Table Travel..... 5-1/2" in.
 Head Swivel..... 360 deg.
 Max. Dist Spindle To Column..... 8 in.
 Max. Dist Spindle To Table..... 14-3/8" in.
 Drilling Cap For Cast Iron..... 1 in.
 Drilling Cap For Steel..... 1 in.
 No. Of Vert. Spindle Speeds..... 12
 Range Of Vert. Spindle Speeds..... 110 - 2580 RPM
 Quill Dia..... 2.440 in.

The information contained herein is deemed accurate as of 7/27/2006 and represents our most recent product specifications. Due to our ongoing improvement efforts, this information may not accurately describe items previously purchased.



Table Info

Table Length.....	23 in.
Table Width.....	7-1/2 in.
Table Thickness.....	1-3/4 in.
No. Of T Slots.....	4
T Slots Width.....	1/2 in.
T Slots Height.....	7/8 in.
T Slots Centers.....	1-1/2" in.
Stud Size.....	3/8 in.

Lead Screw Info

Lead Screw Diameter.....	0.935 in.
Lead Screw TPI.....	10
Lead Screw Length.....	X-Axis 30"; Y-Axis 15-3/4"

Construction

Spindle Housing Const.....	Cast Iron
Table Const.....	Ground Cast Iron
Head Const.....	Cast Iron
Column Const.....	Ground Cast Iron
Base Const.....	Cast Iron
Paint.....	Enamel

Other

Collars Calibrated.....	0.001 in.
Column Dia.....	3-5/8"
Optional Stand.....	G5943
Mobile Base.....	G7314

Spindle Info

Spindle Taper.....	R-8
Spindle Sleeve Diameter.....	2.44"
End Milling Cap.....	1/2 in.
Face Milling Cap.....	3 in.
Draw Bar Diameter.....	7/16 in.
Draw Bar TPI.....	7/16 - 20
Draw Bar Length.....	13-1/2 in.
Spindle Bearings.....	Tapered Roller

Other Specifications:

ISO Factory	ISO 9001
Country Of Origin	Taiwan
Warranty	1 Year
Serial Number Location	Machine Label on Head Casting
Assembly Time	30 minutes
Sound Rating	80 dB

Features:

- Head Swivels 360 deg.
- Front Mounted On/Off Switch
- Excellent Speed Range
- Extremely Quiet Machine
- Easy Clutch-Type Mechanism for Engaging Fine Down-Feed
- Positive Quill Lock
- Adjustable Gibs on Table & Saddle
- Adjustable Stops on Table
- Spindle Supported by Heavy Duty, Tapered Roller Bearings
- Graduations in Inches

The information contained herein is deemed accurate as of 7/27/2006 and represents our most recent product specifications. Due to our ongoing improvement efforts, this information may not accurately describe items previously purchased.



Identification

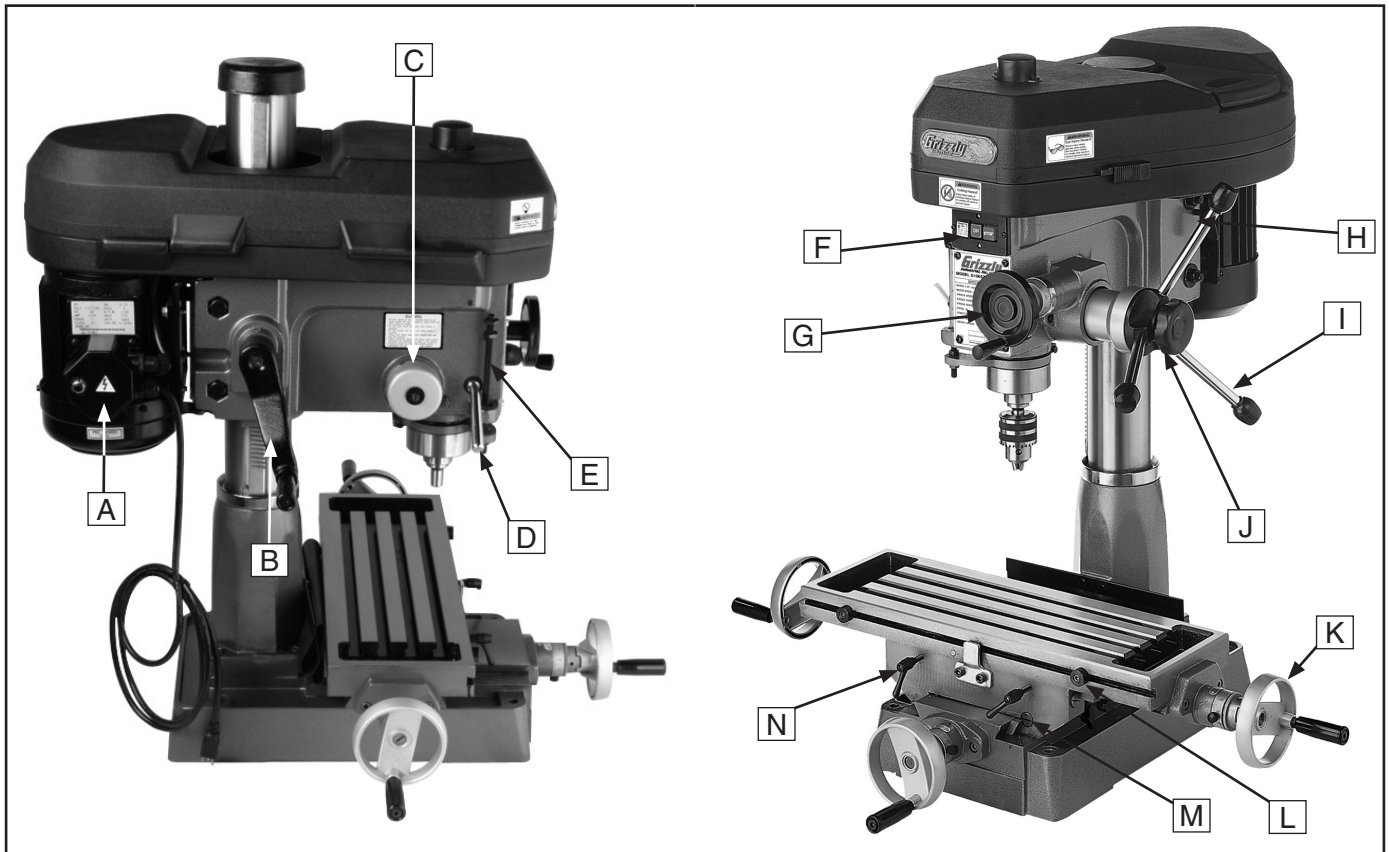

Figure 1. G1005Z Identification.

- A. Junction Box
- B. Headstock Height Crank
- C. Return Spring Assembly
- D. Quill Lock
- E. Depth Stop
- F. ON/OFF Switch
- G. Micro-Downfeed Handwheel
- H. Motor Pivot Lock
- I. Downfeed Handles
- J. Pinion Hub Lock Knob
- K. Table Handwheels
- L. Longitudinal Stops
- M. Gib Screws
- N. Longitudinal Locks



SECTION 1: SAFETY

WARNING

For Your Own Safety, Read Instruction Manual Before Operating this Machine

The purpose of safety symbols is to attract your attention to possible hazardous conditions. This manual uses a series of symbols and signal words which are intended to convey the level of importance of the safety messages. The progression of symbols is described below. Remember that safety messages by themselves do not eliminate danger and are not a substitute for proper accident prevention measures.



Indicates an imminently hazardous situation which, if not avoided, **WILL** result in death or serious injury.



Indicates a potentially hazardous situation which, if not avoided, **COULD** result in death or serious injury.



Indicates a potentially hazardous situation which, if not avoided, **MAY** result in minor or moderate injury. It may also be used to alert against unsafe practices.

NOTICE

This symbol is used to alert the user to useful information about proper operation of the machine.

WARNING

Safety Instructions for Machinery

- 1. READ THROUGH THE ENTIRE MANUAL BEFORE STARTING MACHINERY.** Machinery presents serious injury hazards to untrained users.
- 2. ALWAYS USE ANSI APPROVED SAFETY GLASSES WHEN OPERATING MACHINERY.** Everyday eyeglasses only have impact resistant lenses—they are NOT safety glasses.
- 3. ALWAYS WEAR A NIOSH APPROVED RESPIRATOR WHEN OPERATING MACHINERY THAT PRODUCES DUST.** Wood dust is a carcinogen and can cause cancer and severe respiratory illnesses.
- 4. ALWAYS USE HEARING PROTECTION WHEN OPERATING MACHINERY.** Machinery noise can cause permanent hearing damage.
- 5. WEAR PROPER APPAREL. DO NOT** wear loose clothing, gloves, neckties, rings, or jewelry which may get caught in moving parts. Wear protective hair covering to contain long hair and wear non-slip footwear.
- 6. NEVER OPERATE MACHINERY WHEN TIRED, OR UNDER THE INFLUENCE OF DRUGS OR ALCOHOL.** Be mentally alert at all times when running machinery.



WARNING

Safety Instructions for Machinery

7. **ONLY ALLOW TRAINED AND PROPERLY SUPERVISED PERSONNEL TO OPERATE MACHINERY.** Make sure operation instructions are safe and clearly understood.
8. **KEEP CHILDREN AND VISITORS AWAY.** Keep all children and visitors a safe distance from the work area.
9. **MAKE WORKSHOP CHILD PROOF.** Use padlocks, master switches, and remove start switch keys.
10. **NEVER LEAVE WHEN MACHINE IS RUNNING.** Turn power **OFF** and allow all moving parts to come to a complete stop before leaving machine unattended.
11. **DO NOT USE IN DANGEROUS ENVIRONMENTS.** DO NOT use machinery in damp, wet locations, or where any flammable or noxious fumes may exist.
12. **KEEP WORK AREA CLEAN AND WELL LIT.** Clutter and dark shadows may cause accidents.
13. **USE A GROUNDED EXTENSION CORD RATED FOR THE MACHINE AMPERAGE.** Undersized cords overheat and lose power. Replace extension cords if they become damaged. DO NOT use extension cords for 220V machinery.
14. **ALWAYS DISCONNECT FROM POWER SOURCE BEFORE SERVICING MACHINERY.** Make sure switch is in OFF position before reconnecting.
15. **MAINTAIN MACHINERY WITH CARE.** Keep blades sharp and clean for best and safest performance. Follow instructions for lubricating and changing accessories.
16. **MAKE SURE GUARDS ARE IN PLACE AND WORK CORRECTLY BEFORE USING MACHINERY.**
17. **REMOVE ADJUSTING KEYS AND WRENCHES.** Make a habit of checking for keys and adjusting wrenches before turning machinery **ON**.
18. **CHECK FOR DAMAGED PARTS BEFORE USING MACHINERY.** Check for binding and alignment of parts, broken parts, part mounting, loose bolts, and any other conditions that may affect machine operation. Repair or replace damaged parts.
19. **USE RECOMMENDED ACCESSORIES.** Refer to the instruction manual for recommended accessories. The use of improper accessories may cause risk of injury.
20. **DO NOT FORCE MACHINERY.** Work at the speed for which the machine or accessory was designed.
21. **SECURE WORKPIECE.** Use clamps or a vise to hold the workpiece when practical. A secured workpiece protects your hands and frees both hands to operate the machine.
22. **DO NOT OVERREACH.** Keep proper footing and balance at all times.
23. **MANY MACHINES WILL EJECT THE WORKPIECE TOWARD THE OPERATOR.** Know and avoid conditions that cause the workpiece to "kickback."
24. **ALWAYS LOCK MOBILE BASES (IF USED) BEFORE OPERATING MACHINERY.**
25. **BE AWARE THAT CERTAIN DUST MAY BE HAZARDOUS** to the respiratory systems of people and animals, especially fine dust. Make sure you know the hazards associated with the type of dust you will be exposed to and always wear a respirator approved for that type of dust.



WARNING

Additional Safety for Mill/Drills

- 1. UNDERSTANDING CONTROLS.** Make sure you understand the use and operation of all controls.
- 2. SAFETY ACCESSORIES.** Always use a chip guard in addition to your safety glasses when milling to prevent bodily injury.
- 3. WORK HOLDING.** Before starting the machine, be certain the workpiece has been properly clamped to the table. NEVER hold the workpiece by hand when using the mill/drill.
- 4. CHUCK KEY SAFETY.** Always remove your chuck key, drawbar wrench, and any service tools immediately after use.
- 5. SPINDLE SPEEDS.** Select the spindle speed that is appropriate for the type of work and material. Allow the mill/drill to gain full speed before beginning a cut.
- 6. STOPPING SPINDLE.** DO NOT stop the spindle by hand. Allow it to come to a stop by itself.
- 7. AVOIDING ENTANGLEMENT.** Keep loose clothing articles such as sleeves, belts or jewelry items away from the mill/drill spindle. Never wear gloves when operating the mill/drill.
- 8. BE ATTENTIVE.** DO NOT leave mill/drill running unattended for any reason.
- 9. POWER DISRUPTION.** In the event of a local power outage during use of the mill, turn **OFF** all switches to avoid possible sudden start up once power is restored.
- 10. MACHINE CARE AND MAINTENANCE.** Never operate the mill/drill with damaged or worn parts. Maintain your mill/drill in proper working condition. Perform routine inspections and maintenance promptly. Put away adjustment tools after use.
- 11. DISCONNECT POWER.** Make sure the mill/drill is turned **OFF**, disconnected from its power source and all moving parts have come to a complete stop before starting any inspection, adjustment, or maintenance procedure.
- 12. CLEAN-UP.** DO NOT clear chips by hand. Use a brush, and never clear chips while the mill/drill is turning.
- 13. CUTTING TOOL INSPECTION.** Inspect drills and end mills for sharpness, chips, or cracks before each use. Replace dull, chipped, or cracked cutting tools immediately. Handle new cutting tools with care. Leading edges are very sharp and can cause lacerations.
- 14. EXPERIENCING DIFFICULTIES.** If at any time you are experiencing difficulties performing the intended operation, stop using the machine! Contact our Technical Support at (570) 546-9663.

WARNING

Like all machinery there is potential danger when operating this machine. Accidents are frequently caused by lack of familiarity or failure to pay attention. Use this machine with respect and caution to lessen the possibility of operator injury. If normal safety precautions are overlooked or ignored, serious personal injury may occur.

CAUTION

No list of safety guidelines can be complete. Every shop environment is different. Always consider safety first, as it applies to your individual working conditions. Use this and other machinery with caution and respect. Failure to do so could result in serious personal injury, damage to equipment, or poor work results.



SECTION 2: CIRCUIT REQUIREMENTS

110/220V Operation

⚠️ WARNING

Serious personal injury could occur if you connect the machine to the power source before you have completed the set up process. **DO NOT** connect the machine to the power source until instructed to do so.

Amperage Draw

The Model G1005Z features a 110/220V motor that is prewired for 110V and draws the following amps under maximum load:

Motor Draw at 110V 12 Amps
Motor Draw at 220V 6 Amps

Circuit Requirements

We recommend using a dedicated circuit for this machine. You **MUST** connect your machine to a grounded circuit that is rated for the amperage given below. Never replace a circuit breaker on an existing circuit with one of higher amperage without consulting a qualified electrician to ensure compliance with wiring codes. **If you are unsure about the wiring codes in your area or you plan to connect your machine to a shared circuit, consult a qualified electrician.**

110V Circuit..... 15 Amps
220V Circuit..... 15 Amps

Plug Type

The Model G1005Z comes prewired with a NEMA 5-15 plug. If you wish to rewire the motor to 220V we recommend using the following plug (see **Figure 2** for an example):

220V Plug & Receptacle NEMA 6-15

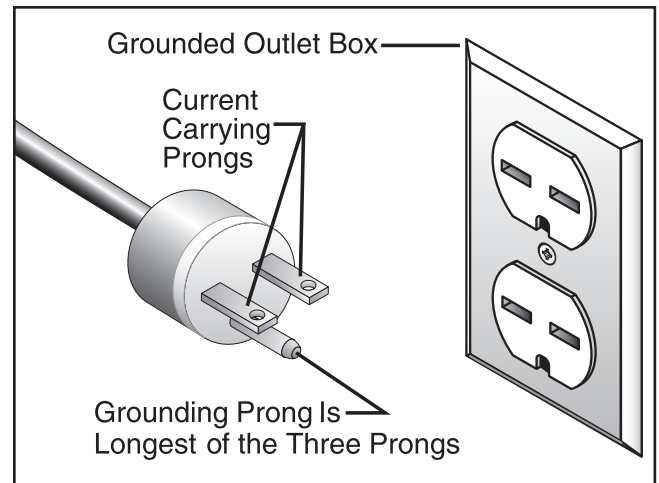
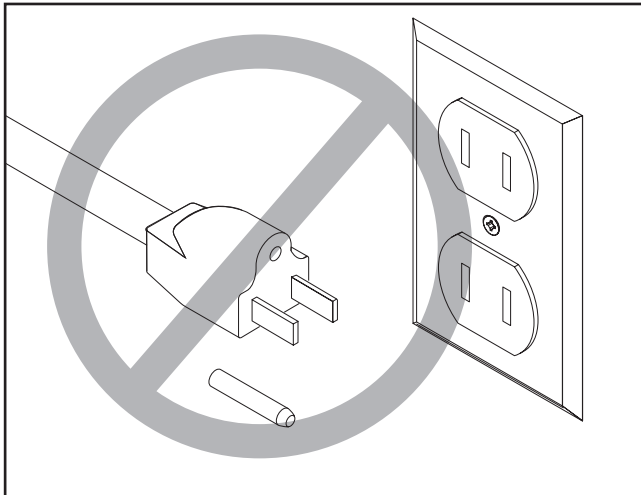
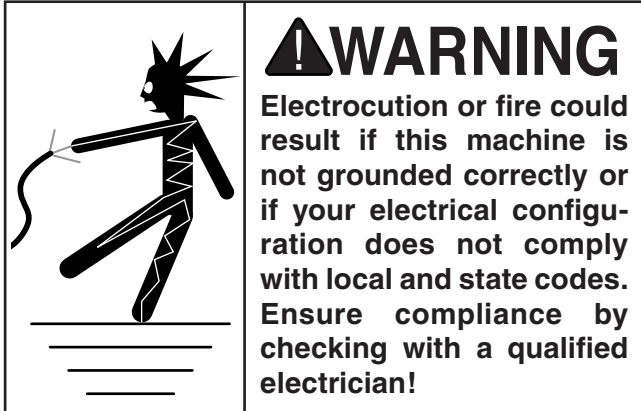

Figure 2. NEMA 6-15 plug and outlet.



Grounding

In the event of an electrical short, grounding reduces the risk of electric shock. The grounding wire in the power cord must be properly connected to the grounding prong on the plug; likewise, the outlet must be properly installed and grounded. All electrical connections must be made in accordance with local codes and ordinances.



! CAUTION

This machine must have a ground prong in the plug to help ensure that it is grounded. **DO NOT** remove ground prong from plug to fit into a two-pronged outlet! If the plug will not fit the outlet, have the proper outlet installed by a qualified electrician.

Extension Cords

110V Operation

We do not recommend the use of extension cords. Instead, arrange the placement of your equipment and the installed wiring to eliminate the need for extension cords.

If you find it absolutely necessary to use an extension cord at 110V with your machine:

- Use at least a 14 gauge cord that does not exceed 50 feet in length!
- The extension cord must also contain a ground wire and plug pin.
- A qualified electrician **MUST** size cords over 50 feet long to prevent motor damage.

220V Operation

We do not recommend the use of extension cords. Instead, arrange the placement of your equipment and the installed wiring to eliminate the need for extension cords.

If you find it absolutely necessary to use an extension cord at 220V with your machine:

- Use at least a 16 gauge cord that does not exceed 50 feet in length!
- The extension cord must also contain a ground wire and plug pin.
- A qualified electrician **MUST** size cords over 50 feet long to prevent motor damage.



SECTION 3: SET UP

Set Up Safety

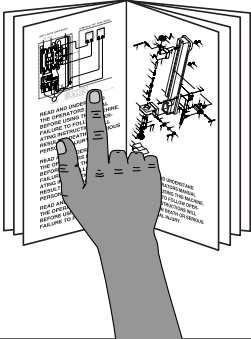

⚠️ WARNING
 This machine presents serious injury hazards to untrained users. Read through this entire manual to become familiar with the controls and operations before starting the machine!



⚠️ WARNING
 Wear safety glasses during the entire set up process!



⚠️ WARNING
 The Model G1005Z is an extremely heavy machine (400 lbs). Serious personal injury may occur if safe moving methods are not followed. To be safe, you will need power equipment when moving the shipping crate, and a number of assistants when moving the machine onto a stand or workbench.

Items Needed for Set Up

The following items are needed to complete the set up process, but are not included with your machine:

Description	Qty
• Safety Glasses (for each person)	1
• Rubber Mallet	1
• Hex Wrench 5mm	1
• Wrench 17mm	1
• Solvent Cleaner	As needed
• Rags for cleaning	As needed

Unpacking

The Model G1005Z was carefully packed when it left our warehouse. If you discover the machine is damaged after you have signed for delivery, *please immediately call Customer Service at (570) 546-9663 for advice.*

Save the containers and all packing materials for possible inspection by the carrier or its agent. *Otherwise, filing a freight claim can be difficult.*

When you are completely satisfied with the condition of your shipment, you should inventory the contents.



Inventory

After all the parts have been removed from the shipping crate, you should have the following items:

Main Components: (Figure 3)		Qty
A.	Mill/Drill (not shown).....	1
B.	Downfeed Handle Knobs 1/2"-12	3
C.	Downfeed Handles 1/2"-12.....	3
D.	Face Mill Arbor R8	1
E.	Chuck Key	1
F.	Handwheels.....	3
G.	Face Mill 2 1/2"	1
H.	Arbor R ⁸ /JT6 (installed, not shown)	1
I.	Handwheel Handles 3/8"-16 x 7/8.....	4
J.	Vise 3 1/2"	1
K.	Drill Chuck JT6 1/2"	1

Other Components and Hardware:

- Cap Screw 3/8"-16 x 1 (mill arbor)
- Flat Washer 3/8" (mill arbor)
- Hex Wrench 4mm
- Hex Wrench 5mm

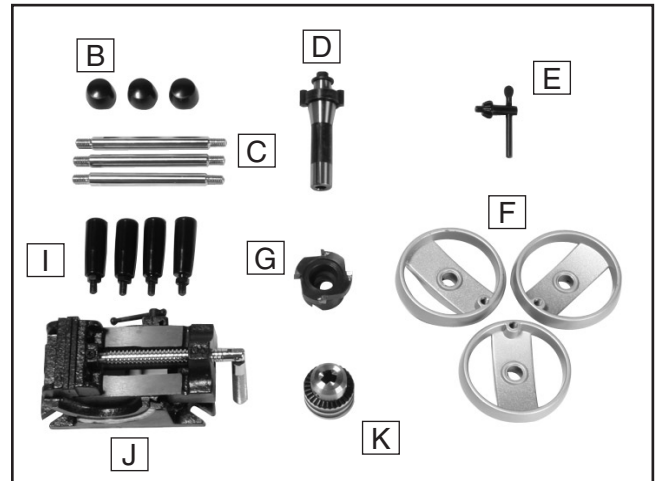

Figure 3. G1005Z Inventory.

In the event that any nonproprietary parts are missing (e.g. a nut or a washer), we would be glad to replace them, or for the sake of expediency, replacements can be obtained at your local hardware store.

NOTICE

Some hardware/fasteners on the inventory list may arrive pre-installed on the machine. Check these locations before assuming that any items from the inventory list are missing.



Clean Up

The unpainted surfaces are coated with a waxy oil to protect them from corrosion during shipment. Remove this protective coating with a solvent cleaner or citrus-based degreaser such as Grizzly's G7895 Degreaser. To clean thoroughly, some parts may need to be removed. **For optimum performance from your machine, make sure you clean all moving parts or sliding contact surfaces that are coated.** Avoid chlorine-based solvents, such as acetone or brake parts cleaner, as they may damage painted surfaces should they come in contact. Always follow the manufacturer's instructions when using any type of cleaning product.

	<p>⚠ WARNING Gasoline and petroleum products have low flash points and could cause an explosion or fire if used to clean machinery. DO NOT use gasoline or petroleum products to clean the machinery.</p>
--	---

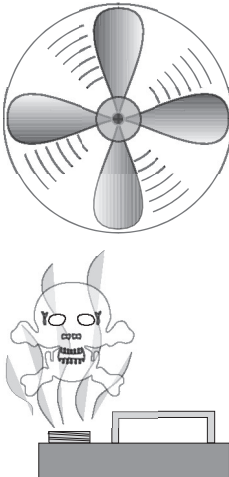
	<p>⚠ CAUTION Many of the solvents commonly used to clean machinery can be toxic when inhaled or ingested. Lack of ventilation while using these solvents could cause serious personal health risks or fire. Take precautions from this hazard by only using cleaning solvents in a well ventilated area.</p>
---	---

Site Considerations

Workbench Load

Refer to the **Machine Data Sheet** for the weight and footprint specifications of your machine. Some workbenches may require additional reinforcement to support both the machine and workpiece.

Operational Clearances

Consider existing and anticipated needs, size of material to be processed through each machine, and space for auxiliary stands, work tables or other machinery when establishing a location for your new machine. See **Figure 4** for the minimum operational clearances.

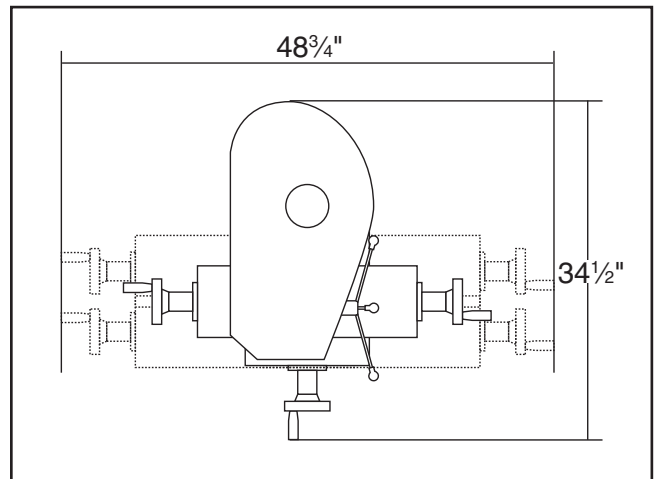

Figure 4. Minimum working clearances.

	<p>⚠ CAUTION Unsupervised children and visitors inside your shop could cause serious personal injury to themselves. Lock all entrances to the shop when you are away and DO NOT allow unsupervised children or visitors in your shop at any time!</p>
--	---



Mounting

The Model G1005Z must be mounted to a workbench or stand before it can be safely used.

If mounting to a stand, follow the mounting instructions included with the stand. We recommend using the Grizzly Model G5943 stand, which can be found in **SECTION 5: ACCESSORIES** on **Page 25**.

For workbenches, the strongest mounting option is a "through mount" where holes are drilled all the way through the workbench, and hex bolts, washers, and hex nuts are used to secure the mill/drill to the workbench.

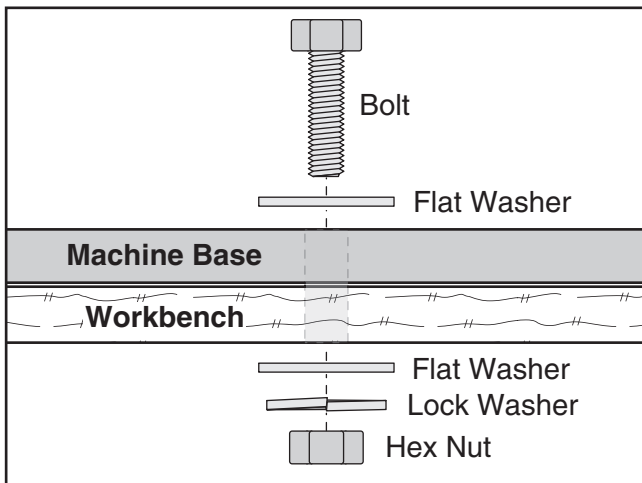

Figure 5. Example of a through mount setup.

Another option for mounting is a "direct mount" where the machine is simply secured to the workbench with a lag screw.

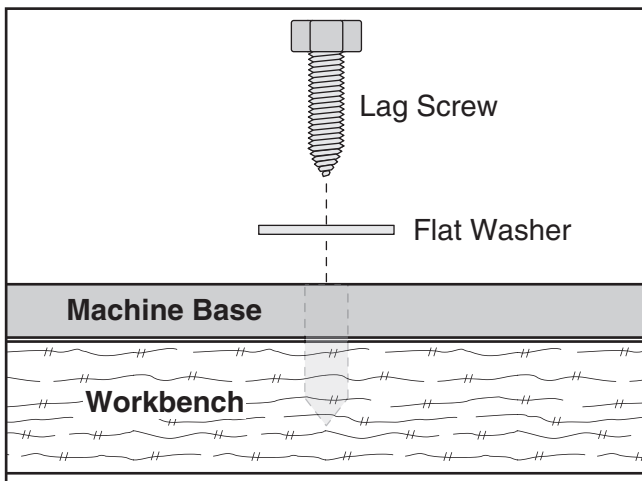

Figure 6. Example of a direct mount setup.

Assembly

The Model G1005Z must be completely assembled before it can be safely used.

To assemble the Model G1005Z:

1. Thread the downfeed handle knobs onto the downfeed handles.
2. Thread the downfeed handles into the pinion hub, as shown in **Figure 7**.

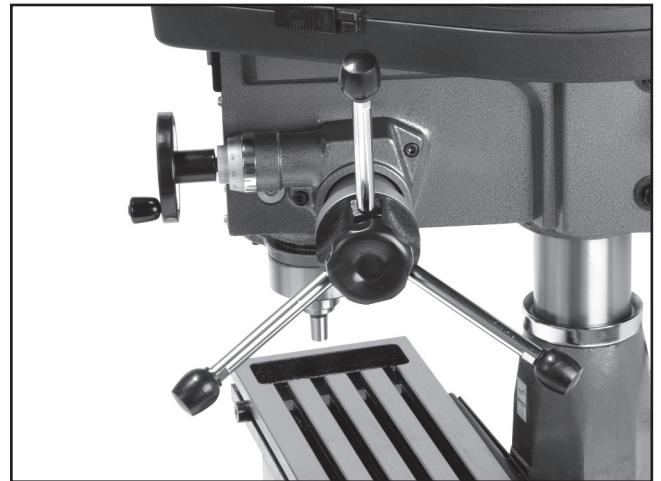

Figure 7. Downfeed handles installed.

3. Remove the caps from the handwheel hubs.
4. Slide the handwheels onto the handwheel shafts as shown in **Figure 8**, and tighten the handwheel setscrews.

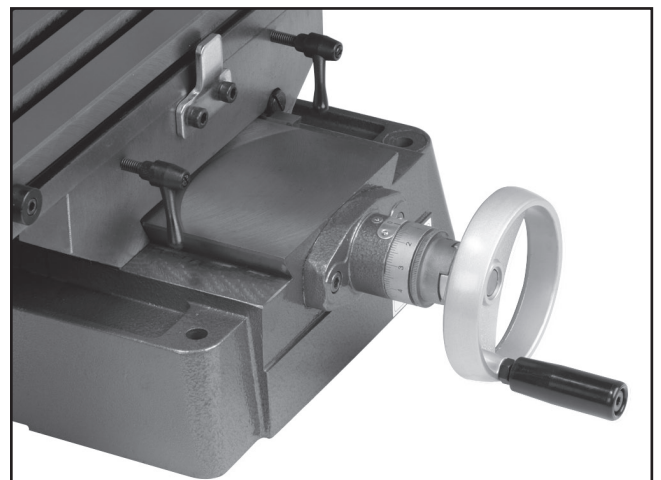

Figure 8. Table handwheels installed.



5. Thread the handwheel handles into the handwheels and tighten using a 5mm hex wrench.
6. Thread the remaining handwheel handle into the headstock adjustment handle.

Test Run

Once the assembly is complete, test run your machine to make sure it runs properly.

If, during the test run, you cannot easily locate the source of an unusual noise or vibration, stop using the machine immediately, then review the **Troubleshooting on Page 27**.

If you still cannot remedy a problem, contact our Tech Support at (570) 546-9663 for assistance.

To test run the machine:

1. Make sure you have read the safety instructions at the beginning of the manual and that the machine is setup properly.
2. Make sure all tools and objects used during set up are cleared away from the machine.
3. Ensure the machine is switched *OFF*.
4. Connect the machine to the power source.
5. Turn the machine **ON**.
6. Listen to and watch for abnormal noises or actions. The machine should run smoothly with little or no vibration or rubbing noises.

—Strange or unusual noises should be investigated and corrected before operating the machine further. Always disconnect the machine from power when investigating or correcting potential problems.



SECTION 4: OPERATIONS

Operation Safety

!WARNING

Damage to your eyes, lungs, and ears could result from using this machine without proper protective gear. Always wear safety glasses, a respirator, and hearing protection when operating this machine.

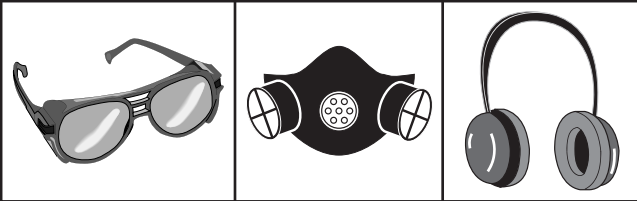

!WARNING

Loose hair and clothing could get caught in machinery and cause serious personal injury. Keep loose clothing and long hair away from moving machinery.

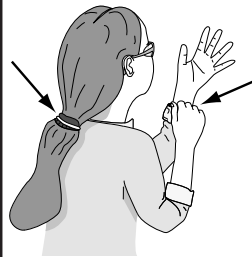

NOTICE

If you have never used this type of machine or equipment before, WE STRONGLY RECOMMEND that you read books, trade magazines, or get formal training before beginning any projects. Regardless of the content in this section, Grizzly Industrial will not be held liable for accidents caused by lack of training.

Installing/Removing Tooling

The Model G1005Z is supplied with both an R8 face mill arbor, for use with the included 2½" face mill, and a JT6 drill chuck.

Using Clean Tapers

When installing any tapered tooling, always ensure that both tapers (the tooling and the spindle) are clean and free of grit, oil, dust, and other debris that could prevent a good fit. Dirty tapers can lead to poor seating, causing loose (and potentially dangerous) tooling, or can cause jammed tapers, making them near impossible to separate.

To install tooling on included mill arbor:

1. UNPLUG THE MILL/DRILL!
2. Seat the tooling on the mill arbor as shown in Figure 9.

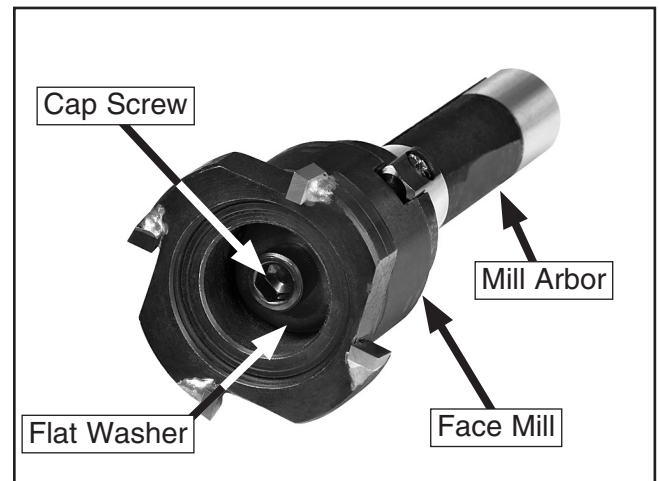

Figure 9. Attaching a face mill to the mill arbor.

3. Secure the tooling in place with the included cap screw and flat washer.



To install an arbor:

1. UNPLUG THE MILL/DRILL!
2. Slide the arbor into the spindle, ensuring that the arbor keyway aligns with the pin inside the spindle.
3. While holding the arbor in place, turn the drawbar clockwise until the drawbar engages with the arbor.
4. Continue turning the drawbar until the arbor is firmly secured in place.

To remove an arbor:

1. UNPLUG THE MILL/DRILL!
2. Using a 17mm wrench, turn the drawbar hex nut counterclockwise two turns, as shown in **Figure 10**.



Figure 10. Turning the drawbar nut.

3. Strike the end of the drawbar with a dead blow mallet to unseat the arbor from the spindle.
4. While holding the arbor, unscrew the drawbar until the arbor comes free.

To install end mill tooling:

1. UNPLUG THE MILL/DRILL!
2. Insert the appropriate-sized R8 collet into the spindle, ensuring that the collet keyway aligns with the pin inside the spindle.
3. Using a heavy rag or gloves to protect your hands, insert the end mill tooling into the collet.
4. While holding the collet in place, turn the drawbar hex nut clockwise until the drawbar engages with the collet.
5. Turn the drawbar nut clockwise until the tooling is completely secured in the collet.

To install the drill chuck:

1. UNPLUG THE MILL/DRILL!
2. Ensure that both the arbor and chuck are clean, dry and free of dirt, debris or grit.
3. Slide the chuck onto the arbor.
4. Securely seat the chuck in place by giving it a single hard tap with a rubber mallet, as shown in **Figure 11**.

Note: Once the chuck is seated on the arbor, it is a semi-permanent connection. If you wish to use a different chuck, we recommend obtaining a new arbor for that chuck.

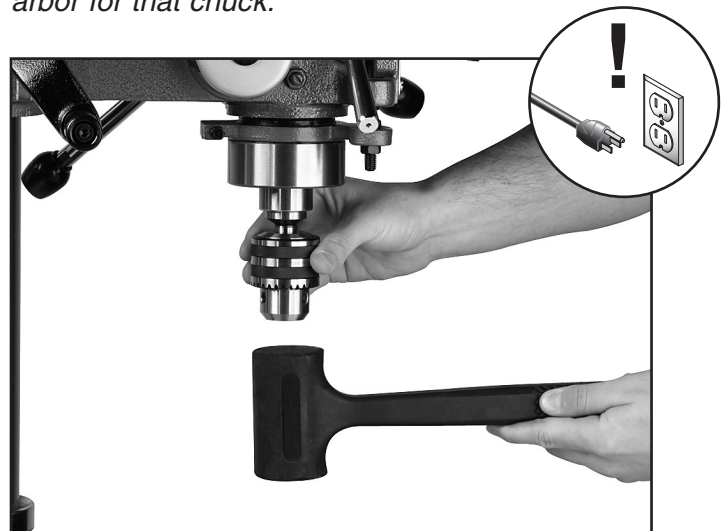

Figure 11. Seating the JT6 drill chuck.



To install a drill bit:

1. UNPLUG THE MILL/DRILL!
2. Open the drill chuck wide enough to accept the shank of the drill bit.
3. Insert the drill bit as far as possible into the chuck WITHOUT allowing the chuck jaws to touch the fluted portion of the bit, and tighten the chuck using the chuck key.

Note: Make sure the bit is not trapped between the edges of two jaws, as it will not be secure enough to use for drilling.

4. Once you are sure the bit is installed correctly, tighten the chuck as tight as possible.

To remove a drill bit:

1. UNPLUG THE MILL/DRILL!
2. Open the drill chuck using the chuck key, and catch the drill bit with a rag to protect your hands.

⚠ CAUTION

Larger bits turning at slower speeds tend to grab the workpiece aggressively. This can result in the operator's hand being pulled into the bit or the workpiece being thrown with great force. Always clamp the workpiece to the table to prevent injuries.

Table

The mill/drill table can be moved in the X-axis (side-to-side) and Y-axis (forward/backward). The various features are called out in **Figure 12** and are described below.

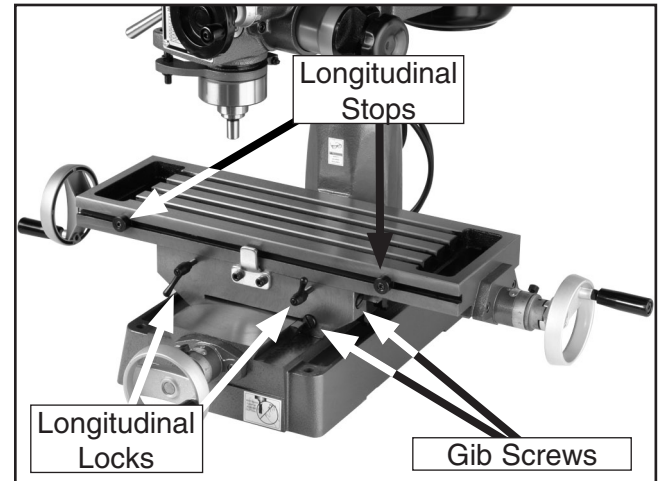

Figure 12. G1005Z table components.

Longitudinal Feed:

The longitudinal feed, or X-axis, is moved by handwheels at either end of the table. These handwheels will move the table in both directions side to side. One complete revolution of the handwheel moves the longitudinal feed 0.100".

Cross Feed:

The cross feed, or Y-axis, is moved with the handwheel on the front of the table base. One complete revolution of the handwheel moves the cross slide 0.100".

Longitudinal Locks:

The longitudinal feed can be temporarily locked in position using one or both lock handles located on the front of the table.

Longitudinal Stops:

The two sliding longitudinal stops are used to limit the X-axis travel distance. These can be loosened and locked in place using a 5mm hex wrench.

Gib Screws:

Both the longitudinal and cross slides can each be locked via a gib screw, located respectively on the right side of the cross slide underneath the table, and on the front right of the cross slide.



Graduated Dials

The handwheels and the micro-downfeed adjustment knob have graduated dials. Each mark represents 0.001" of movement and one full revolution of the micro-downfeed knob equals 0.100". The graduated dials float and can be indexed or "zeroed" using the knurled knob on the dial. One full revolution of the handwheel equals 0.100".

Backlash

Backlash and graduated dials are somewhat interconnected. When you change direction of the table in either axis, you must correct the graduated dial for backlash. Normal recommended backlash is less than 0.010".

Note: *It is up to you to determine an acceptable amount of backlash for your system. The frictional wear on your lead screw increases as backlash is reduced. Attempting to completely eliminate backlash can place excessive wear on your lead screw and decrease its operational capability.*

To correct for backlash:

1. Turn the handwheel and move the table the opposite direction of your next operation.
2. Turn the handwheel to move the table in the intended direction.
3. The exact moment the lead screw catches and the table begins to move, backlash has been eliminated and the graduated dial can be "zeroed."

Note: *You will not need to adjust for backlash as long as the table keeps moving in the same direction.*

Micro-Downfeed Handwheel

The micro-downfeed handwheel (**Figure 13**) is used when vertical milling accuracy is required. Each full rotation of the micro-downfeed handwheel is equal to 0.100".

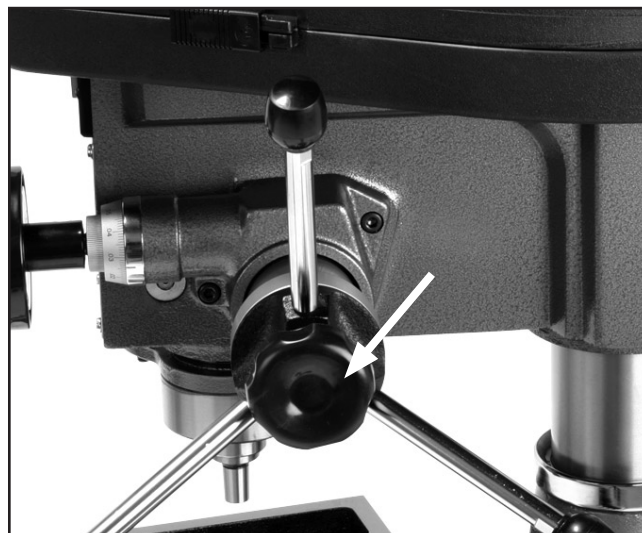

Figure 13. Pinion hub lock knob.

To engage the micro-downfeed handwheel, tighten the pinion hub lock knob clockwise against the pinion hub.

To disengage the micro-downfeed handwheel, hold the downfeed handles and loosen the pinion hub lock knob counterclockwise.



Quill Lock

The spindle can be locked in place to provide tool stability when milling.

To lock the quill in place:

1. Lower the quill to the desired height.
2. Tighten the quill lock handle clockwise to lock the quill in place, as shown in **Figure 14**.

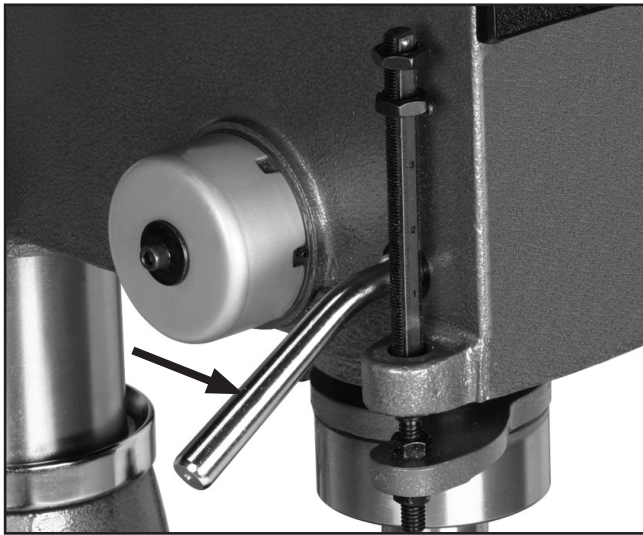

Figure 14. Quill lock handle.

To unlock the quill:

1. While holding the downfeed handles, turn the quill lock handle counterclockwise until the quill is free to move.

Depth Stop

The Model G1005Z has a depth stop that allows you to lower the drill bit or milling tool to the same point every time.

The depth stop consists of a stud attached to the quill with two hex nuts that can be lowered or raised on the stud, so the lower nut (depth nut) hits a stop bracket when the drill bit is lowered. The upper nut (jam nut) is then used to tighten against the depth nut to secure it in place, so the depth nut doesn't move with repeated operations.

The depth stop also features a return height nut that is used to set the minimum spindle return distance. **Figure 15** shows the various components of the depth stop.

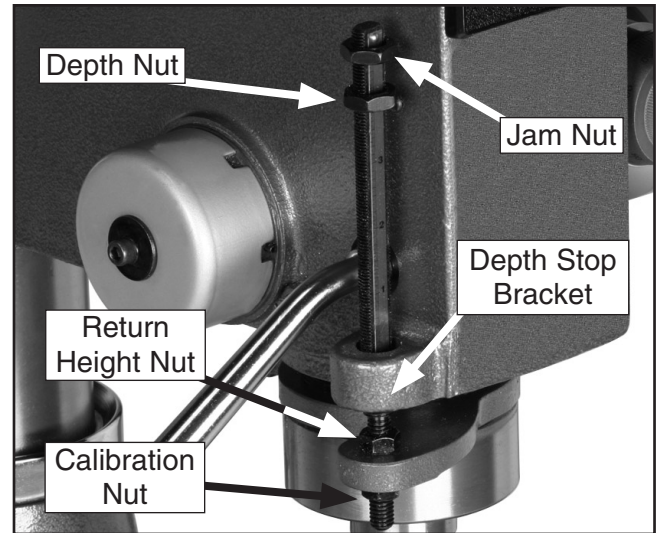

Figure 15. Depth stop components.

To set the depth stop:

1. Lower the tooling/bit to the required height.
2. Thread the depth nut down against the stop bracket.
3. Lower the jam nut against the depth nut.
4. Hold the depth nut in place and tighten the jam nut against the depth nut.

To set the spindle return distance:

1. Lower the tooling/bit.
2. Thread the return height nut up the stud to the desired height.

Note: The scale on the depth stop can be recalibrated if it gets moved or has changed since the factory setting. Refer to **Depth Stop Calibration** on **Page 30** for instructions on how this is done.



Choosing Milling Speeds

It is essential to closely follow the proper cutting speed and proper feed to reduce undue strain on all moving parts and for operator safety.

Prior to machining, you need to determine the RPM needed to cut your workpiece, and then set the speed on the machine.

To determine the needed RPM:

1. Use the table in **Figure 16** to determine the cutting speed required for the material of your workpiece.
2. Measure the diameter of your cutting tool in inches.
3. Use the following formula to determine the needed RPM for your operation:

$$\text{(Cutting Speed x 4) / Tool Diameter} = \text{RPM}$$

Note: For carbide cutting tools, double the cutting speed. These values are a guideline only. Refer to the MACHINERY'S HANDBOOK for more detailed information.

Cutting Speeds for High Speed Steel (HSS) Milling Tools	
Workpiece Material	Cutting Speed (sfm)
Aluminum & alloys	300
Brass & Bronze	150
Copper	100
Cast Iron, soft	80
Cast Iron, hard	50
Mild Steel	90
Cast Steel	80
Alloy Steel, hard	40
Tool Steel	50
Stainless Steel	60
Titanium	50
Plastics	300-800
Wood	300-500

Figure 16. Cutting speeds for HSS cutting tools.

WARNING

Failure to follow RPM and Feed Rate Guidelines may result in ejected parts or broken tools. Parts ejected at high speeds can cause serious injury!

Choosing Drilling Speeds

Using the Drill Bit Speed Chart

The chart shown on **Page 22** is intended as a guide only. Always follow manufacturer's speed recommendations if provided with your drill bits, cutters, or hole saws. Exceeding the recommended speeds may be dangerous to the operator.

The speeds shown here are intended to get you started. The optimum speed will always depend on various factors, including tool diameter, drilling pressure, material hardness, material quality, and desired finish.

Often, when drilling materials other than wood, some type of lubrication is necessary.

Lubrication Suggestions

Wood/Cast IronNone
 Plastics Soapy Water
 Brass Water-Based Lubricant
 Aluminum.....Paraffin-Based Lubricant
 Mild Steel.....Oil-Based Lubricant



Twist/Brad Point Drill Bits	Soft Wood	Hard Wood	Plastic	Brass	Aluminum	Mild Steel
1/16" – 3/16"	3000	2500	2500	2500	3000	2500
13/64" – 3/8"	2000	1500	2000	1250	2500	1250
25/64" – 5/8"	1500	750	1500	750	1500	600
11/16" – 1"	750	500	1000	400	1000	350
Spade/Forstner Bits	Soft Wood	Hard Wood	Plastic	Brass	Aluminum	Mild Steel
1/4" – 1/2"	2000	1500				
9/16" – 1"	1500	1250				
1-1/8" – 1-7/8"	1000	750				
2–3"	500	350				
Hole Saws	Soft Wood	Hard Wood	Plastic	Brass	Aluminum	Mild Steel
1/2" – 7/8"	500	500	600	600	600	500
1" – 1-7/8"	400	400	500	500	500	400
2" – 2-7/8"	300	300	400	400	400	300
3" – 3-7/8"	200	200	300	300	300	200
4" – 5"	100	100	200	200	200	100
Rosette Cutters	Soft Wood	Hard Wood	Plastic	Brass	Aluminum	Mild Steel
Carbide Insert Type	350	250				
One-Piece Type	1800	500				
Tenon/Plug Cutters	Soft Wood	Hard Wood	Plastic	Brass	Aluminum	Mild Steel
3/8" – 1/2"	1200	1000				
5/8" – 1"	800	600				

Figure 17. Drill bit speed chart.

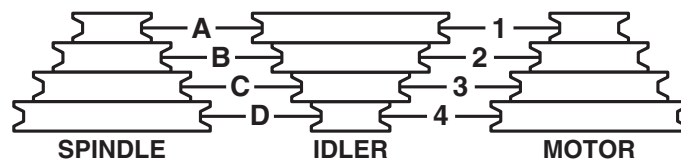

① 110 RPM BELT D-1	② 210 RPM BELT D-2	③ 240 RPM BELT C-1	④ 300 RPM BELT B-1
⑤ 340 RPM BELT D-3	⑥ 440 RPM BELT C-2	⑦ 730 RPM BELT A-2	⑧ 850 RPM BELT B-3
⑨ 1140 RPM BELT A-3	⑩ 1550 RPM BELT C-4	⑪ 1910 RPM BELT B-4	⑫ 2580 RPM BELT A-4

Figure 18. Belt configuration and speed settings.



Changing Speeds

The belts in the head of the mill/drill must be rearranged to change speeds. A chart on the belt cover shows the belt positions needed to make the mill/drill run at the desired speed.

To change speeds:

1. UNPLUG THE MILL/DRILL!
2. Loosen the motor lock screw (shown in **Figure 19**), so the motor is free to pivot.

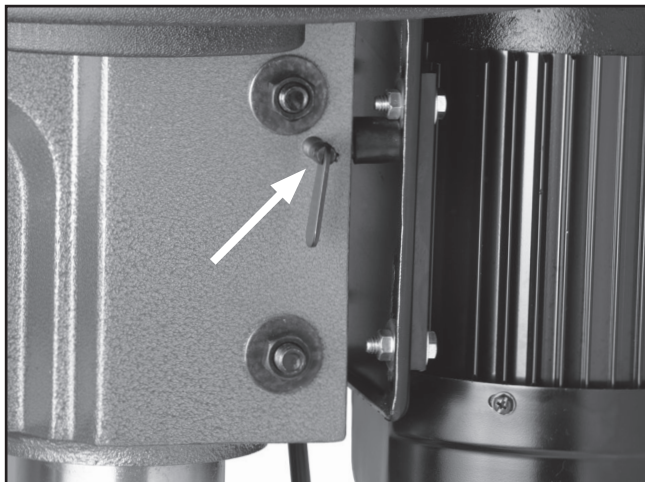

Figure 19. Motor lock screw.

3. Pivot the motor to loosen the belt tension.
4. Loosen, but do not remove, the two idler bracket hex bolts shown in **Figure 20**.

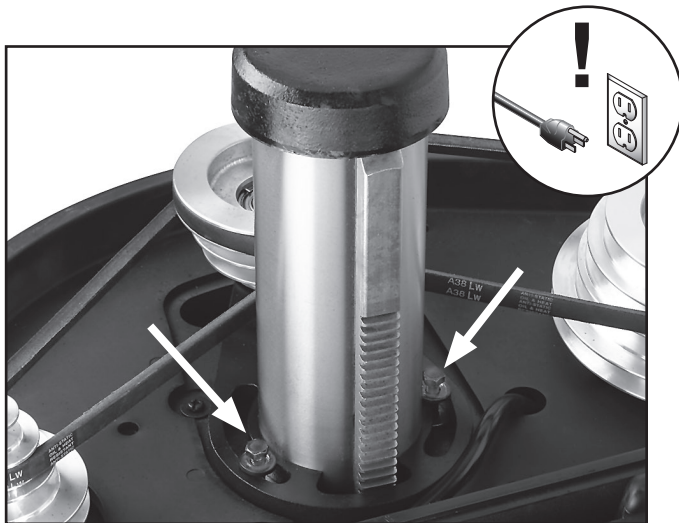

Figure 20. Idler bracket hex bolts.

5. Locate the desired speed on the belt cover speed chart or on **Page 22** and move the V-belts to the desired V-grooves on the motor, idler, and spindle pulleys.

For Example: As indicated in the speed chart (**Figure 21**), a belt combination of **A-2** creates 730 RPM.

Note: Both belts may have to be removed before certain speed changes can be made. It is normal for the idler bracket to move in response to a belt change.

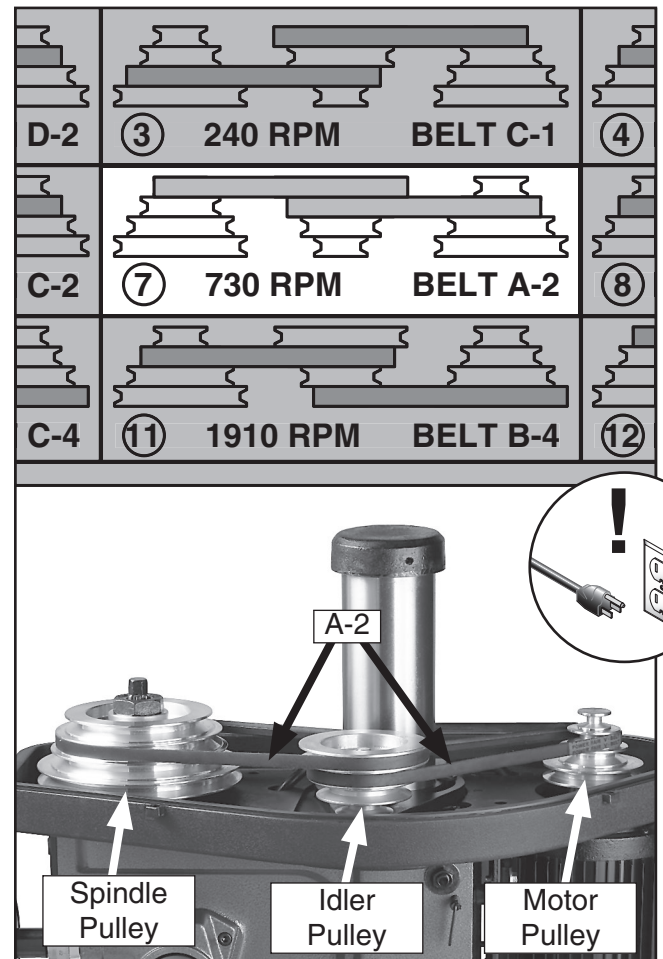

Figure 21. A-2 pulley combination for 730 RPM.

6. Tighten both idler bracket hex bolts.
7. Remove any slack in the motor pulley belt by shifting the motor back into position.
8. Tighten the motor lock screw.
9. Close the cover before plugging in the machine.



Drilling Guidelines

The Model G1005Z is designed for drilling holes in wood, plastics or metal. Basic operation consists of lining up your drill bit with the intended hole location, turning the mill/drill **ON**, and using the downfeed handles to move the spinning drill bit into the workpiece.

For safe operation and optimum results, it is very important to follow these guidelines when drilling:

SECURING WORKPIECE TO TABLE: Secure the workpiece to the table or in a vise that is secured to the table before drilling.

CLEARING CHIPS: Raise the drill bit often to clear chips and cool the drill bit. This will ease the work of the mill/drill motor and extend the life of your drill bits.

PROTECTING TABLE: Protect the table by placing the workpiece on scrap wood. Also, use the depth stop so that the drill bit goes no deeper than necessary.

USING CORRECT SPEEDS: Use the correct speed for the diameter of the drill bit being used and the type of material being drilled. Refer to the **Drill Bit Speed Chart** on **Page 22** to help you choose the correct speed for your application.

LARGE DIAMETER BITS: Large diameter drill bits require slower spindle speeds.

SMALL DIAMETER BITS: Smaller diameter drill bits require faster spindle speeds.

HARD MATERIAL: The harder the material, (steel vs. wood) the slower the spindle speed.

SOFT MATERIAL: The softer the material, the faster the spindle may turn. (Plastics can melt at too high of a spindle speed!)

LUBRICANT: Use some form of lubricant on all materials except wood. Refer to **Lubrication Suggestions** on **Page 21** to find the correct lubrication for your application.

DRILLING ACCURACY: To prevent drill bit wandering and ensure accurate placement of holes, mark the hole location with a center punch before drilling. Also consider using a center-point drill to start the hole.

PLUG/ROSETTE CUTTERS: Plug cutters and rosette cutters are for wood only. However, carbide-tipped bits and cutters cut at a higher speed and can cut materials other than wood, depending on the cutter type.

5-FLUTE/2-FLUTE CUTTERS: Use a 5-flute cutter when cutting into plastics, brass, aluminum, and mild steel. A 2-flute cutter can aggressively grab the workpiece and damage the tool if used with materials other than wood.

SPADE BITS AND PLASTIC: When drilling plastic with a spade bit, use a spade bit with spurs.

HOLE SAWS: When using hole saws, apply firm and even pressure, so the saw teeth contact the surface all at the same time—not at an angle. You can also flip the workpiece and finish cutting from the other side.

CAUTION

Larger bits turning at slower speeds tend to grab the workpiece aggressively. This can result in the operator's hand being pulled into the bit or the workpiece being thrown with great force. Always clamp the workpiece to the table to prevent injuries.



SECTION 5: ACCESSORIES

G7984—Face Shield

H1298—Dust Sealed Safety Glasses

H1300—UV Blocking, Clear Safety Glasses

H2347—Uvex® Spitfire Safety Glasses

H0736—Shop Fox® Safety Glasses

Safety Glasses are essential to every shop. If you already have a pair, buy extras for visitors or employees. You can't be too careful when it comes to shop safety!



Figure 22. Our most popular safety glasses.

G5943—Stand for Model G1005Z Mill/Drill

This companion stand for the Model G1005Z Mill/Drill features a snap-style door handle and raised lip to guard against coolant splashes.



Figure 23. G5943 Stand for G1005Z.

H2689—R8 Quick Change Collet Set

An affordable quick change collet system with ultra precision. These spring collets are hardened and ground to exacting tolerances and offer incredible holding power. This set includes an R8 arbor and nut, spanner wrench, plastic carrying case and collets sized 1/8", 1/4", 3/8", 1/2", 5/8", 3/4", 7/8", and 1". What's more, the nut features a self-ejecting rim! A set like this will truly speed up any tool changing process. Drawbar size is 7/16" x 20.

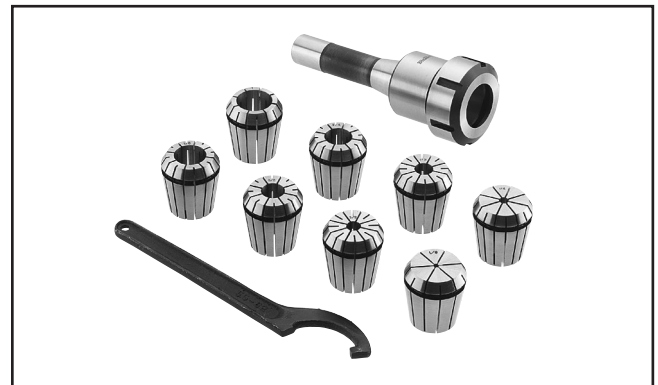

Figure 24. H2689 R8 Quick Change Collet Set.

G9760—20-PC. 2 & 4 Flute TiN End Mill Set.

Includes these sizes and styles in two and four flute styles: 3/16", 1/4", 5/16", 3/8", 7/16", 1/2", 9/16", 5/8", 3/8", 11/16", and 3/4".

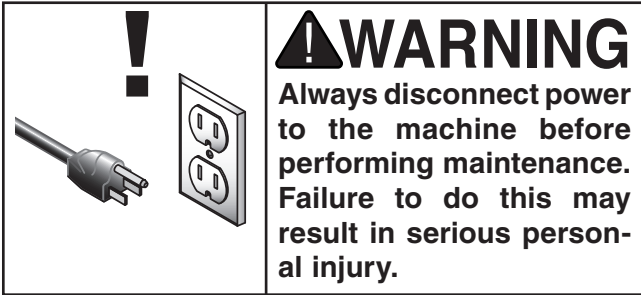

Figure 25. G9760 20-PC End Mill Set.

Call 1-800-523-4777 To Order



SECTION 6: MAINTENANCE



Schedule

For optimum performance from your machine, follow this maintenance schedule and refer to any specific instructions given in this section.

Daily Check:

- Loose mounting bolts.
- Worn or damaged wires.
- Any other unsafe condition.
- Mill/drill is completely powered down at the end of use.
- Excess cutting fluids and chips have been removed and unpainted surfaces are dry and protected.

Weekly Maintenance:

- Clean/grease all dovetail ways.
- Mill/drill is clean and lubricated.

Cleaning

Cleaning the Model G1005Z is relatively easy. Remove excess cutting fluid and chips, and wipe off the remaining moisture with a dry cloth. Treat all unpainted cast iron and steel with a non-staining lubricant after cleaning.

Unpainted Cast Iron

Protect the unpainted cast iron surfaces on the table by wiping the table clean after every use—this ensures moisture does not remain on bare metal surfaces.

Keep tables rust-free with regular applications of products like G96® Gun Treatment, SLIPIT®, or Boeshield® T-9.

Lubrication

Since all bearings are shielded and permanently lubricated, simply leave them alone until they need to be replaced. DO NOT lubricate them.

Keep quill, spindle, column, and table top well lubricated to prevent rust.

Each table handwheel must be oiled periodically to prevent binding. For each handwheel, use an ISO VG 68 or SAE-20 oil in the location shown in **Figure 26**.



Figure 26. Handwheel oiling location.



SECTION 7: SERVICE

Review the troubleshooting and procedures in this section to fix your machine if a problem develops. If you need replacement parts or you are unsure of your repair skills, then feel free to call our Technical Support at (570) 546-9663.

Troubleshooting

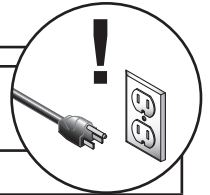

Motor & Electrical

Symptom	Possible Cause	Possible Solution
Machine does not start or a breaker trips.	<ol style="list-style-type: none"> 1. Plug or receptacle is at fault or wired incorrectly. 2. Start capacitor is faulty. 3. Motor connection is wired incorrectly. 4. Power supply is faulty, or is switched OFF. 5. ON/OFF switch is faulty. 6. Cable or wiring is open or has high resistance. 7. Motor is at fault. 	<ol style="list-style-type: none"> 1. Test power plug and receptacle for good contact and correct wiring. 2. Replace capacitor. 3. Correct motor wiring (see Page 33). 4. Make sure all hot lines and grounds are operational and have correct voltage on all legs. 5. Replace faulty switch. 6. Troubleshoot wires for internal or external breaks, check for disconnected or corroded connections and repair or replace wiring. 7. Test, repair or replace motor.
Machine stalls or is underpowered.	<ol style="list-style-type: none"> 1. Incorrect spindle speed for task. 2. Machine is undersized for the task. 3. Belt(s) is slipping. 4. Plug or receptacle is at fault. 5. Motor connection is wired incorrectly. 6. Pulley is slipping on shaft. 7. Motor bearings are at fault. 8. Motor has overheated. 9. Motor is at fault. 10. Feed rate is too high. 	<ol style="list-style-type: none"> 1. Decrease spindle speed. 2. Use smaller drill bits/cutters and reduce feed rate and spindle speed. 3. Replace bad belts, align pulleys, and re-tension. 4. Test power plug and receptacle for good contact and correct wiring. 5. Correct motor wiring (see Page 33). 6. Replace loose pulley and shaft. 7. Rotate motor shaft for noisy or burnt bearings, repair/replace as required. 8. Let cool, clean linside/outside of motor, and reduce workload on machine. 9. Test, repair or replace motor. 10. Reduce feed rate.



Symptom	Possible Cause	Possible Solution
Machine has vibration or noisy operation.	<ol style="list-style-type: none"> 1. Motor or component is loose. 2. Belts are slapping belt cover. 3. V-belt(s) is worn or is loose. 4. Motor fan is rubbing on fan cover. 5. Pulley is loose. 6. Machine is incorrectly mounted to the bench, or the bench is uneven. 7. Chuck or cutter is at fault. 8. Motor bearings are at fault. 9. Spindle bearings at fault. 	<ol style="list-style-type: none"> 1. Inspect, replace for damaged bolts/nuts and retighten with thread locking fluid. 2. Replace/realign belts with a new matched set, and retension belts (refer to Page 23). 3. Replace belts. 4. Replace/repair dented fan cover, and replace loose or damaged fan. 5. Remove pulley, replace with key as required, and re-install securely. 6. Make sure bench mounting hardware is tight; place shims under machine. 7. Replace out-of-round chuck, replace or sharpen cutter, use appropriate feed rate and cutting RPM. 8. Check bearings, replace motor or bearings as required. 9. Replace bearing.

Operation

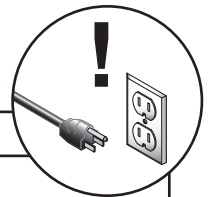

Symptom	Possible Cause	Possible Solution
Milling/drilling stops, but the motor still operates.	<ol style="list-style-type: none"> 1. The belt is loose or worn. 2. The pulley for the spindle shaft or the motor is slipping on the shaft. 3. Drill bit slips in chuck. 	<ol style="list-style-type: none"> 1. Replace and/or adjust the belt. 2. To resecure the pulley: <ol style="list-style-type: none"> a. UNPLUG THE MILL/DRILL! b. Remove nut and slipping pulley. c. Clean all dust, grit and debris from the pulley arbor. d. Warm the pulley and nut so that they slide back onto the pulley arbor. e. Tighten the nut. 3. Tighten bit; inspect bit for burrs or other obstructions that might interfere with clamping surface.
Chuck, arbor or tooling wobbles or is loose on the spindle shaft.	<ol style="list-style-type: none"> 1. Foreign material is stuck between the arbor-to-spindle mating surface. 2. Damaged tooling or chuck. 	<ol style="list-style-type: none"> 1. Remove the chuck and clean and de-burr the tapered chuck and spindle mating surfaces, then reassemble. 2. Replace.
The spindle does not retract completely in the uppermost position or it binds.	<ol style="list-style-type: none"> 1. The quill shaft is gummy with sawdust and oil. 2. The feed shaft return spring is weak. 3. The quill deflection screw is binding the quill. 	<ol style="list-style-type: none"> 1. Clean the gummy substance with penetrating oil and lubricate with a light coat of oil. 2. Increase the feed shaft return spring tension as described on Page 30. 3. Loosen jam nut, and slightly turn out screw where the quill binds. Retighten jam nut and recheck for binding and looseness at all spindle locations.
The quill has excessive deflection.	<ol style="list-style-type: none"> 1. The quill shaft is at fault. 2. The quill and/or bearings are worn. 	<ol style="list-style-type: none"> 1. Adjust the quill screw. 2. Replace the quill and/or bearings.



Symptom	Possible Cause	Possible Solution
Drill bit wobbles, holes are over-sized.	<ol style="list-style-type: none"> 1. Drill bit installed incorrectly. 2. Drill bit is bent. 	<ol style="list-style-type: none"> 1. Remove drill bit and reinstall. 2. Replace drill bit.
Tool slips in collet.	<ol style="list-style-type: none"> 1. Collet is not fully drawn up into spindle taper. 2. Wrong size collet. 3. Debris in collet or in spindle taper. 4. Taking too big of a cut. 	<ol style="list-style-type: none"> 1. Snug up draw bar. 2. Measure tool shank diameter and match with appropriate diameter collet. 3. Remove all oil and debris from collet and spindle taper. 4. Lessen depth of cut and allow chips to clear.
Breaking tools or cutters.	<ol style="list-style-type: none"> 1. RPM and or feed rate is too fast. 2. Cutting tool getting too hot. 3. Taking too big of a cut. 	<ol style="list-style-type: none"> 1. Use tables to set correct RPM and feed rates. 2. Use cutting fluid or oil for appropriate application. 3. Lessen depth of cut and allow chips to clear.
Machine is loud when cutting, overheats or bogs down in the cut.	<ol style="list-style-type: none"> 1. Excessive depth of cut. 2. Dull cutting tools. 3. RPM and feed rate too high. 	<ol style="list-style-type: none"> 1. Decrease depth of cut. 2. Use sharp cutting tools. 3. Use appropriate RPM and feed for the job.
Workpiece vibrates or chatters during operation.	<ol style="list-style-type: none"> 1. Table locks not tight. 2. Spindle lock not tight. 3. Workpiece not securely clamped to table or into mill/drill vice. 4. RPM and feed rate too high. 	<ol style="list-style-type: none"> 1. Tighten down table locks. 2. Tighten spindle lock. 3. Check that clamping is tight and sufficient for the job. Make sure mill/drill vice is tight to the table. 4. Use appropriate RPM and feed for the job.
Table hard to move.	<ol style="list-style-type: none"> 1. Table locks are tightened down. 2. Chips have loaded up on bedways. 3. Bedways are dry and in need of lubrication. 4. Longitudinal stops are interfering. 5. Gibs are too tight. 	<ol style="list-style-type: none"> 1. Make sure table locks are fully released. 2. Frequently clean away chips that load up during milling operations. 3. Lubricate bedways and handles. 4. Check to make sure that stops are loose and not hitting the center stop. 5. Loosen gib screw(s).
Bad surface finish.	<ol style="list-style-type: none"> 1. Wrong RPM or feed rate. 2. Dull cutting tool or poor cutting tool selection. 3. Wrong rotation of cutting tool. 4. Workpiece not securely clamped. 	<ol style="list-style-type: none"> 1. Adjust for appropriate RPM and feed rate. 2. Sharpen cutting tool or select a better cutting tool for the intended operation. 3. Check for proper cutting rotation for cutting tool. 4. Secure properly.



Depth Stop Calibration

The Model G1005Z comes fitted with a depth stop to use when drilling multiple holes at the same depth. The scale on this depth stop can be calibrated if it ever becomes incorrect.

To calibrate the depth stop:

1. Loosen the calibration nut shown in **Figure 27**.

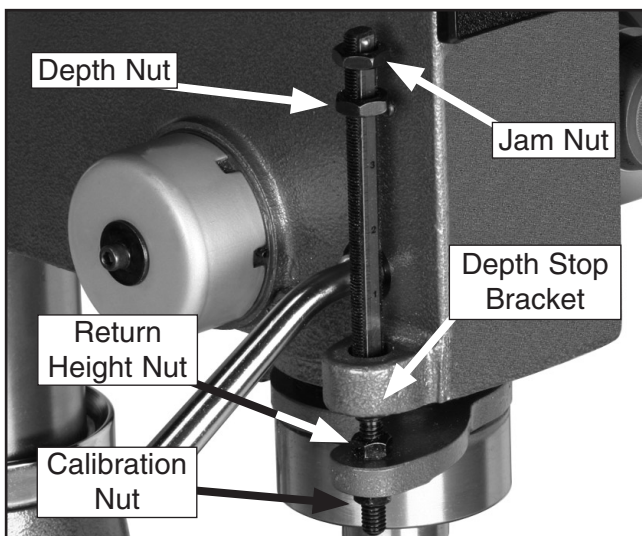

Figure 27. Depth stop assembly.

2. Set the depth nut to zero, and secure it with the jam nut.
3. Tighten the calibration nut to hold the depth stop in position.
4. Move the depth nut and jam nut to a non-zero measurement to allow the spindle to move.
5. Test the depth stop by measuring how far the spindle actually moves from where you set the depth stop.

Feed Shaft Spring Tension

The feed shaft return spring is adjusted at the factory; however, during the life of the mill/drill you may want to adjust the feed shaft return spring so the return pressure suits your operating needs.



To adjust the feed shaft spring tension:

1. UNPLUG THE MILL/DRILL!
2. Wipe off any oil on the spring lock cover so it does not slip in your fingers when you hold the cover from spinning (see **Figure 28** for spring lock cover identification).

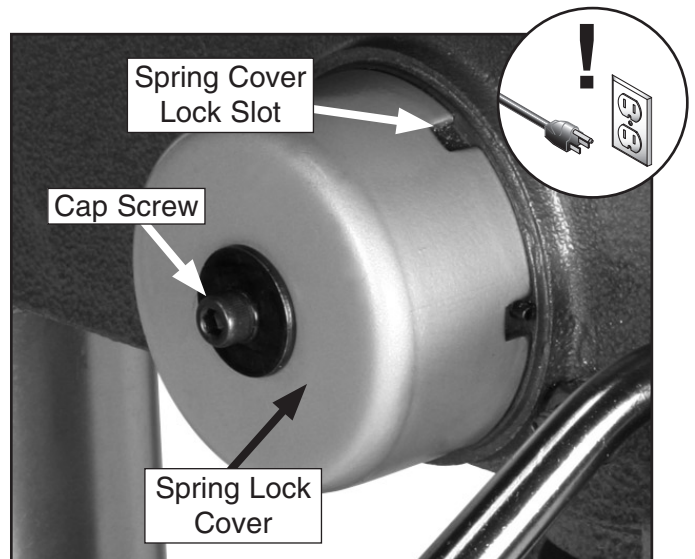

Figure 28. Return spring assembly.



CAUTION

A high tension coiled spring is underneath the cover. Put on heavy leather gloves to protect your hands from possible injury when removing the cover.



Figure 29. Loosening cover and cap screw.

- Put on heavy leather gloves to protect your hands from possible injury if the spring uncoils during the next step.
- While holding the spring lock cover against the side of the head stock so the cover stays splined with the locking lug; loosen the cap screw approximately $\frac{1}{4}$ " (see **Figure 29**).
- Pull the cover outward just enough to disengage the spring-cover lock slot from the locking lug.
Note: *It is important to keep a good grip during this step. Letting go of the cover will cause the spring to rapidly uncoil, which could cause serious injury!*
- Rotate the cover counterclockwise to increase spring tension, or let the cover slowly unwind in the clockwise direction to reduce spring tension.
- Engage the next available spring-cover lock slot with the locking lug and hold the spring cover tightly against the side of the head stock.
- Tighten the lock nut against the spring cover just until the cap screw stops, and then back off the cap screw approximately $\frac{1}{3}$ turn, or just enough so there is no binding at complete spindle travel.



Electrical Components

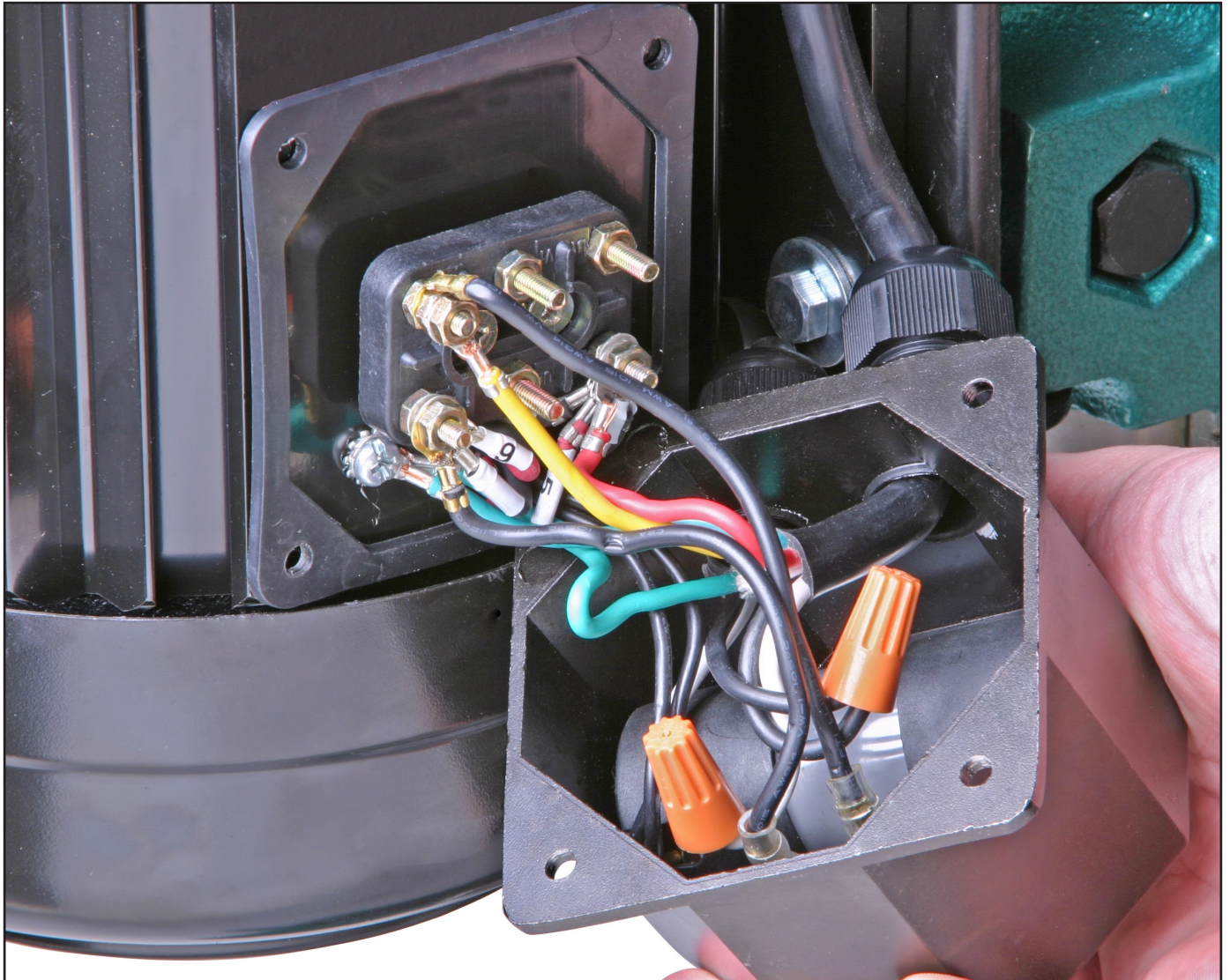

Figure 30. G1005Z Junction Box.



Wiring Diagram



G1005Z WIRING DIAGRAM

COLOR KEY	
BLACK	
WHITE	
GREEN	
RED	
YELLOW	

⚠ DANGER

Disconnect power before performing any electrical service. Electricity presents serious shock hazards that will result in severe personal injury and even death!

⚠ WARNING!

SHOCK HAZARD! Disconnect power before working on wiring.

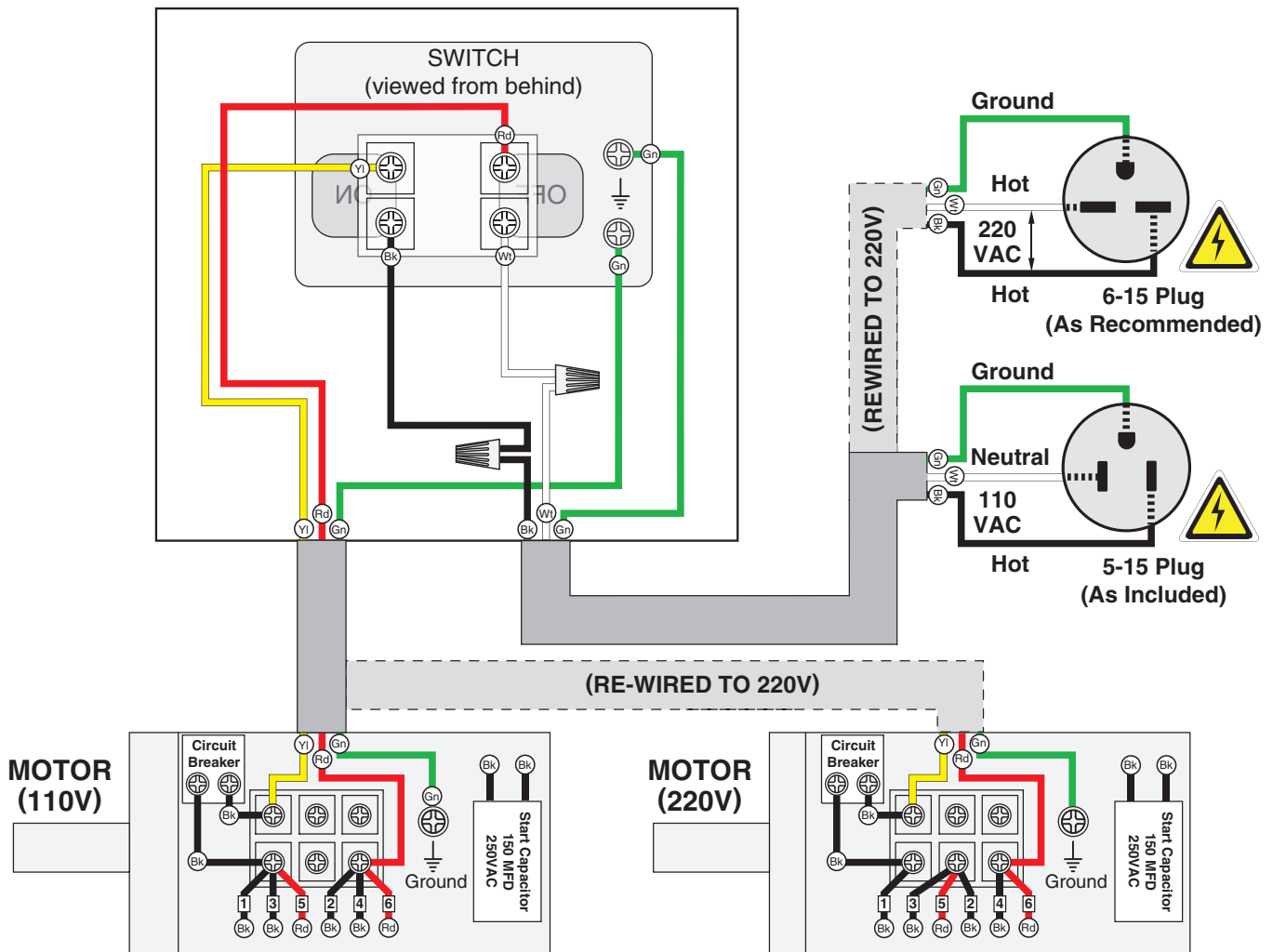

G1005Z Main Assembly Breakdown

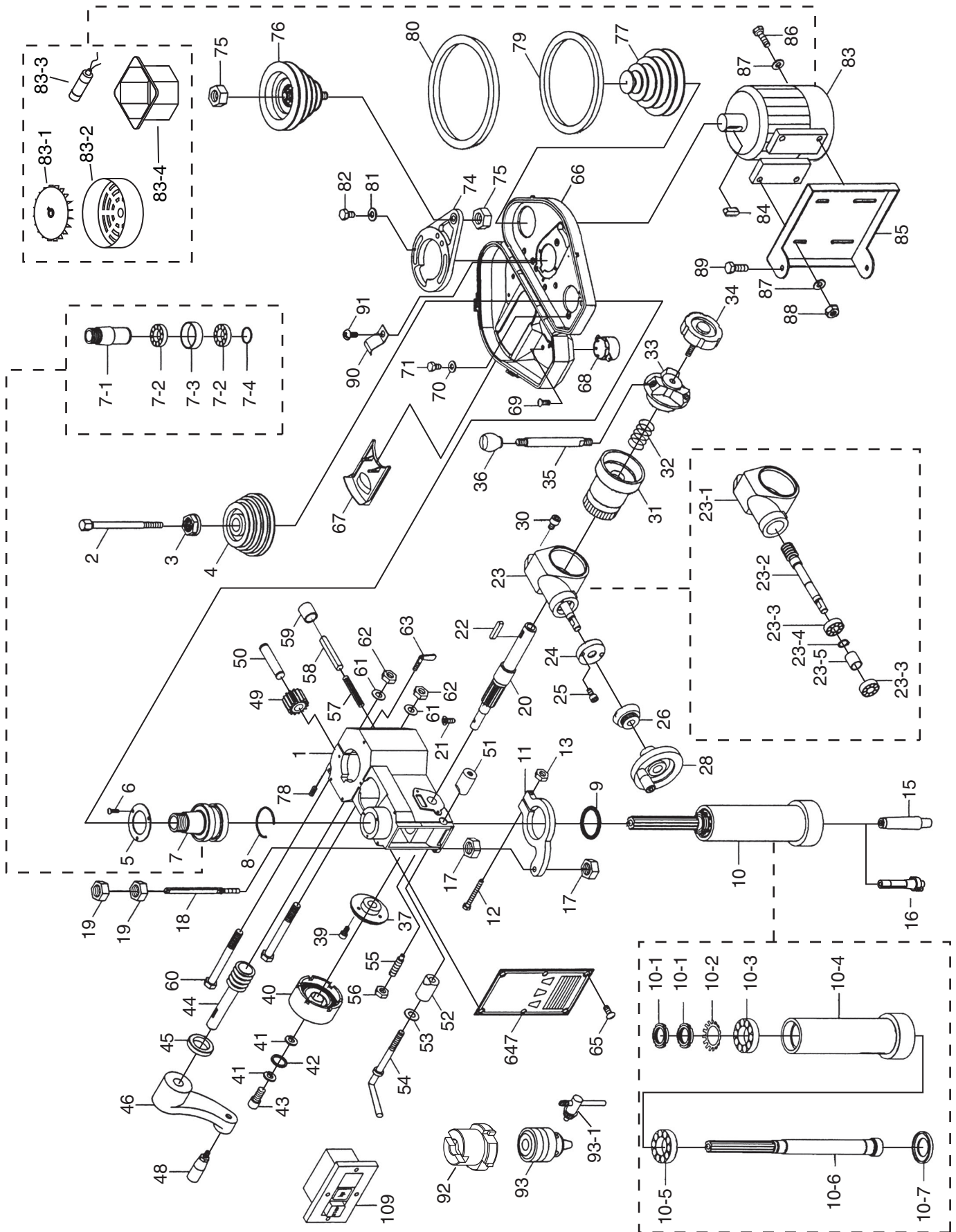

G1005Z Main Assembly Parts List

REF	PART #	DESCRIPTION
1	P1005001	HEAD BODY
2	P1005002	CHUCK ARBOR BOLT 7/16-20
3	P1005003	SPINDLE LOCKNUT 34 X 16
4	P1005004	SPINDLE PULLEY
5	P1005005	OUTER BEARING PLATE
6	PS04	PHLP HD SCR 1/4-20 X 1/2
7	P1005007	SPINDLE TAPER SLEEVE SET
7-1	P1005007-1	SPINDLE TAPER SLEEVE
7-2	P6007	BALL BEARING 6007ZZ
7-3	P1005007-3	WASHER 60 X 55 X 16
7-4	PR12M	EXT RETAINING RING 35MM
8	P1005Z008	EXT RETAINING RING 61MM
9	P1005Z009	RUBBER SEAL
10	P1005010	RACK SLEEVE SET
10-1	P1005010-1	SPANNER NUT 24.5-20
10-2	P1005Z010-2	EXT TOOTH WASHER 25
10-3	P30205	TAPERED ROLLER BEARING 30205
10-4	P1005Z010-4	RACK SLEEVE
10-5	P30206	TAPERED ROLLER BEARING 30206
10-6	P1005010-6	SPINDLE SHAFT
10-7	P1005010-7	BEARING CAP
11	P1005011	FEED BASE
12	PB10	HEX BOLT 1/4-20 X 2
13	PN05	HEX NUT 1/4-20
15	P1005015	CHUCK ARBOR R8 W7/16-20
16	P1005016	CUTTER ARBOR R8 W7/16-20
17	PN08	HEX NUT 3/8-16
18	P1005018	GRADUATED ROD SET
19	PN01	HEX NUT 1/2-20
20	P1005020	PINION SHAFT
21	PFH08	FLAT HD SCR 10-24 X 1/2
22	PK25M	KEY 7 X 7 X 20
23	P1005023	FEED COVER SET
23-1	P1005023-1	FEED COVER
23-2	P1005023-2	WORM SHAFT
23-3	P6202	BALL BEARING 6202ZZ
23-4	PR05M	EXT RETAINING RING 15MM
23-5	P1005Z023-5	SPACER 34 X 28
24	P1005024	WORM COVER
25	PS06	PHLP HD SCR 10-24 X 3/8
26	P1005Z026	MICRO ADJUSTING INDICATOR
28	P1005Z028	HANDWHEEL ASSEMBLY
30	PSB07	CAP SCREW 5/16-18 X 3/4
31	P1005031	WORM GEAR
32	P1005Z032	COMPRESSION SPRING 11/16 X 1
33	P1005Z033	PINION HUB
34	P1005Z034	PINION HUB CAP
35	P1005Z035	DOWNFEED HANDLE 1/2-12
36	P1005Z036	DOWNFEED HANDLE KNOB 1/2-12
37	P1005Z037	COIL SPRING BASE
39	PS08	PHLP HD SCR 10-24 X 3/4
40	P1005Z040	COIL SPRING & SPRING COVER
41	PLW02	LOCK WASHER 1/4
42	PW06	FLAT WASHER 1/4

REF	PART #	DESCRIPTION
43	PSB01	CAP SCREW 1/4-20 X 5/8
44	P1005044	WORM SHAFT
45	P1005045	BUSHING
46	P1005Z046	CRANK ARM
48	P1005Z048	CRANK HANDLE
49	P1005049	WORM GEAR
50	P1005Z050	WORM GEAR SHAFT
51	P1005Z051	GIB
52	P1005Z052	GIB
53	PW01	FLAT WASHER 1/2
54	P1005Z054	LOCK HANDLE
55	P1005Z055	SPECIAL SET SCREW 3/8-16 X 32
56	PN08	HEX NUT 3/8-16
57	P1005Z057	COMPRESSION SPRING 1/2 X 3-1/16
58	P1005058	PIN
59	P1005Z059	RUBBER BUSHING
60	P1005Z060	HEX BOLT 1/2-12 X 6-3/4
61	PW01	FLAT WASHER 1/2
62	PN06	HEX NUT 1/2-12
63	P1005063	THUMB SCREW 3/8-16 X 17
65	PS09	PHLP HD SCR 1/4-20 X 1/4
66	P1005066	BELT COVER
67	P1005Z067	SLIDING COVER
68	P1005068	SPINDLE COVER
69	P1005Z069	FLAT HD SCR M3-0.5 X 15
70	PW06	FLAT WASHER 1/4
71	PS04	PHLP HD SCR 1/4-20 X 1/2
74	P1005Z074	IDLER PULLEY BASE
75	PN04	HEX NUT 5/8-11
76	P1005Z076	IDLER PULLEY SET
77	P1005077	MOTOR PULLEY SET
78	P1005078	OILER 1/4
79	PVA30	V-BELT A-30 4L300
80	PVA38	V-BELT A-38 4L380
81	PW07	FLAT WASHER 5/16
82	PB11	HEX BOLT 5/16-18 X 1-1/2
83	P1005083	MOTOR 1HP 110V/220V 60HZ 1PH
83-1	P1005Z083-1	MOTOR FAN
83-2	P1005Z083-2	MOTOR FAN COVER
83-3	P1005Z083-3	START CAPACITOR 150 MFD 250VAC
83-4	P1005Z083-4	MOTOR JUNCTION BOX
84	P1005084	KEY 7 X 7 X 38
85	P1005085	MOTOR MOUNT PLATE
86	PB03	HEX BOLT 5/16-18 X 1
87	PW07	FLAT WASHER 5/16
88	PN02	HEX NUT 5/16-18
89	PB34	HEX BOLT 3/8-16 X 1/2
90	P1005090	WIRE RELIEF RETAINER
91	PS04	PHLP HD SCR 1/4-20 X 1/2
92	P1005092	MILLING CUTTER
93	P1005093	CHUCK 1/2-JT6
93-1	P1005093-1	CHUCK KEY
109	P1005109	SWITCH



G1005Z Table Breakdown

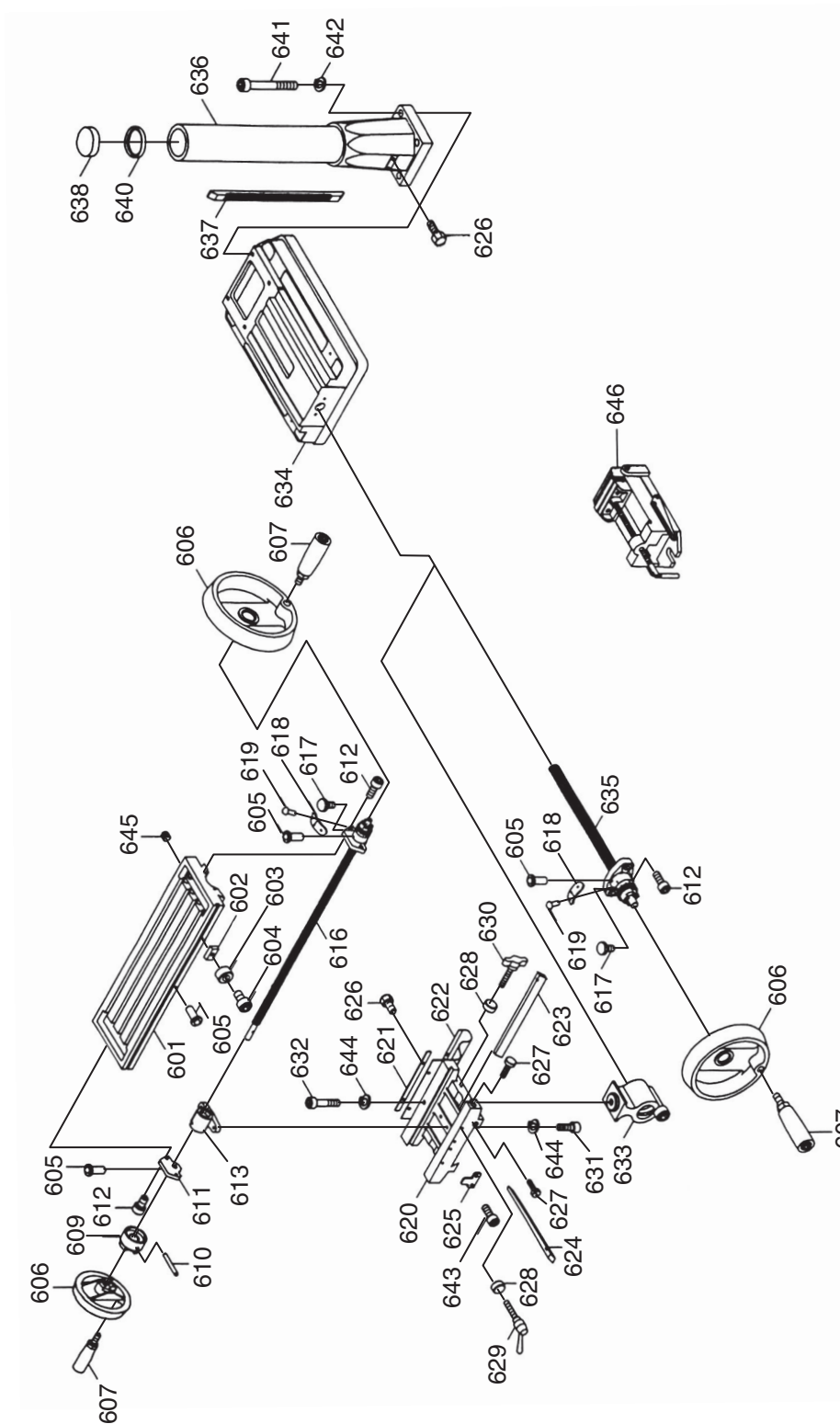

G1005Z Table and Labels Parts List

REF	PART #	DESCRIPTION
601	P1005601	TABLE
602	P1005602	FIXED BLOCK
603	P1005603	MOVABLE FIXED RING
604	PSB04	CAP SCREW 1/4-20 X 1/2
605	P1005605	OILER 1/4
606	P1005606	HAND WHEEL
607	P1005Z607	HANDWHEEL HANDLE
609	P1005609	TABLE CLUTCH
610	PRP82M	ROLL PIN 5 X 38
611	P1005611	LEFT FLANGE
612	PSB07	CAP SCREW 5/16-18 X 3/4
613	P1005Z613	TABLE NUT 23.5-10
616	P1005Z616	ACME SCREW 1/4-20 X 762
617	P1005Z617	KNURLED THUMB SCREW M6-1 x 10
618	P1005618	LIMIT PLATE
619	P1005619	RIVET 2
620	P1005Z620	TABLE BASE
621	P1005621	ANTIDUST PLATE
622	P1005622	ANTIDUST PLATE
623	P1005623	GIB STRIP
624	P1005624	GIB STRIP
625	P1005625	MOVABLE FIXED BLOCK
626	PB09	HEX BOLT 5/16-18 X 1/2
627	P1005627	GIB STRIP BOLT 5/16-18 X 42
628	P1005628	BUSHING

REF	PART #	DESCRIPTION
629	P1005Z629	LOCK HANDLE 5/16-18 X 1-3/8
630	P1005630	T SCREW 5/16-18 X 42
631	PSB03	CAP SCREW 5/16-18 X 1
632	PSB69	CAP SCREW 5/16-18 X 1/4
633	P1005Z633	ACME NUT 23.5 X 10
634	P1005634	SWIVEL BASE
635	P1005Z635	ACME SCREW 23.5 X 10 X 390
636	P1005636	COLUMN BASE
637	P1005637	RACK
638	P1005638	COLUMN HEAD SET
640	P1005640	COLUMN FLANGE RING
641	PSB20	CAP SCREW 7/16-14 X 2
642	PLW05	LOCK WASHER 7/16
643	PSB07	CAP SCREW 5/16-18 X 3/4
644	PLW01	LOCK WASHER 5/16
645	P1005645	PLUG
646	P1005646	WISE
647	P1005Z647	MACHINE NAME PLATE
648	P1005Z648	MACHINE SPEED CHART
649	P1005Z649	READ MANUAL HORIZ SMALL
650	P1005Z650	SAFETY GLASSES HORIZ SMALL
651	P1005Z651	HAND MILL WARNING SMALL
652	P1005Z652	MACHINE WARNING LABEL
653	XLABEL04S	ELECTRICITY

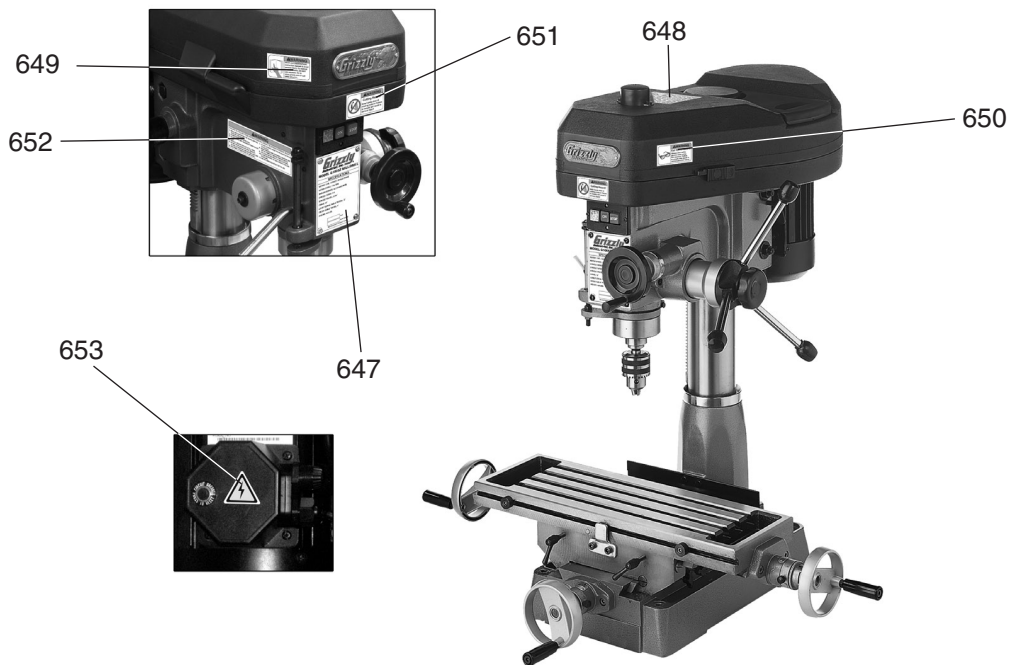

⚠ WARNING

Safety labels warn about machine hazards and ways to prevent injury. The owner of this machine **MUST** maintain the original location and readability of the labels on the machine. If any label is removed or becomes unreadable, **REPLACE** that label before using the machine again. Contact Grizzly at (800) 523-4777 or www.grizzly.com to order new labels.



WARRANTY AND RETURNS

Grizzly Industrial, Inc. warrants every product it sells for a period of **1 year** to the original purchaser from the date of purchase. This warranty does not apply to defects due directly or indirectly to misuse, abuse, negligence, accidents, repairs or alterations or lack of maintenance. This is Grizzly's sole written warranty and any and all warranties that may be implied by law, including any merchantability or fitness, for any particular purpose, are hereby limited to the duration of this written warranty. We do not warrant or represent that the merchandise complies with the provisions of any law or acts unless the manufacturer so warrants. In no event shall Grizzly's liability under this warranty exceed the purchase price paid for the product and any legal actions brought against Grizzly shall be tried in the State of Washington, County of Whatcom.

We shall in no event be liable for death, injuries to persons or property or for incidental, contingent, special, or consequential damages arising from the use of our products.

To take advantage of this warranty, contact us by mail or phone and give us all the details. We will then issue you a "Return Number," which must be clearly posted on the outside as well as the inside of the carton. We will not accept any item back without this number. Proof of purchase must accompany the merchandise.

The manufacturers reserve the right to change specifications at any time because they constantly strive to achieve better quality equipment. We make every effort to ensure that our products meet high quality and durability standards and we hope you never need to use this warranty.

Please feel free to write or call us if you have any questions about the machine or the manual.

Thank you again for your business and continued support. We hope to serve you again soon.





WARRANTY CARD

Name _____
 Street _____
 City _____ State _____ Zip _____
 Phone # _____ Email _____ Invoice # _____
 Model # _____ Order # _____ Serial # _____

The following information is given on a voluntary basis. It will be used for marketing purposes to help us develop better products and services. **Of course, all information is strictly confidential.**

1. How did you learn about us?

Advertisement Friend Catalog
 Card Deck Website Other:

2. Which of the following magazines do you subscribe to?

<input type="checkbox"/> Cabinet Maker	<input type="checkbox"/> Popular Mechanics	<input type="checkbox"/> Today's Homeowner
<input type="checkbox"/> Family Handyman	<input type="checkbox"/> Popular Science	<input type="checkbox"/> Wood
<input type="checkbox"/> Hand Loader	<input type="checkbox"/> Popular Woodworking	<input type="checkbox"/> Wooden Boat
<input type="checkbox"/> Handy	<input type="checkbox"/> Practical Homeowner	<input type="checkbox"/> Woodshop News
<input type="checkbox"/> Home Shop Machinist	<input type="checkbox"/> Precision Shooter	<input type="checkbox"/> Woodsmith
<input type="checkbox"/> Journal of Light Cont.	<input type="checkbox"/> Projects in Metal	<input type="checkbox"/> Woodwork
<input type="checkbox"/> Live Steam	<input type="checkbox"/> RC Modeler	<input type="checkbox"/> Woodworker West
<input type="checkbox"/> Model Airplane News	<input type="checkbox"/> Rifle	<input type="checkbox"/> Woodworker's Journal
<input type="checkbox"/> Modeltec	<input type="checkbox"/> Shop Notes	<input type="checkbox"/> Other:
<input type="checkbox"/> Old House Journal	<input type="checkbox"/> Shotgun News	

3. What is your annual household income?

\$20,000-\$29,000 \$30,000-\$39,000 \$40,000-\$49,000
 \$50,000-\$59,000 \$60,000-\$69,000 \$70,000+

4. What is your age group?

20-29 30-39 40-49
 50-59 60-69 70+

5. How long have you been a woodworker/metalworker?

0-2 Years 2-8 Years 8-20 Years 20+ Years

6. How many of your machines or tools are Grizzly?

0-2 3-5 6-9 10+

7. Do you think your machine represents a good value?

Yes No

8. Would you recommend Grizzly Industrial to a friend?

Yes No

9. Would you allow us to use your name as a reference for Grizzly customers in your area?

Note: We never use names more than 3 times.

Yes No

10. Comments: _____

CUT ALONG DOTTED LINE

FOLD ALONG DOTTED LINE



Place Stamp Here



GRIZZLY INDUSTRIAL, INC.
P.O. BOX 2069
BELLINGHAM, WA 98227-2069



FOLD ALONG DOTTED LINE

Send a Grizzly Catalog to a friend:

Name _____
Street _____
City _____ State _____ Zip _____

TAPE ALONG EDGES--PLEASE DO NOT STAPLE

grizzly.com

TOOL WEBSITE

Buy Direct and Save with Grizzly® – Trusted, Proven and a Great Value!

*Visit Our Website Today And Discover
Why Grizzly® Is The Industry Leader!*

- SECURE ORDERING
- ORDERS SHIPPED WITHIN 24 HOURS
- E-MAIL RESPONSE WITHIN ONE HOUR

-OR-

Call Today For A **FREE**
Full Color Catalog

1-800-523-4777

