

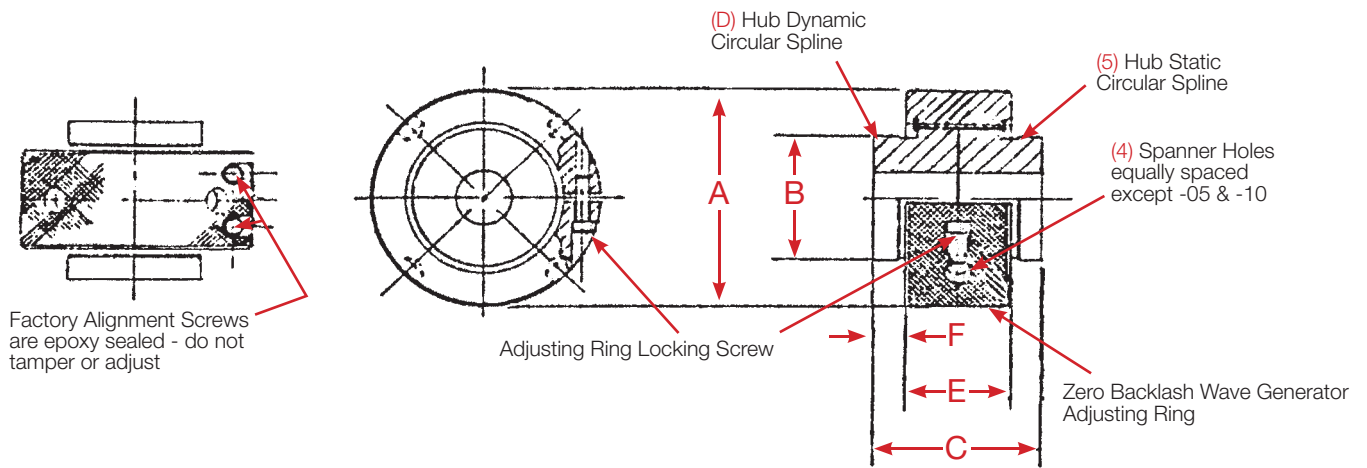

Infini-Indexer[®] *Built-to-Order*



Basic HDI Size	A	B	C	E	F	*Torque Rating lb.-in.	Approximate Weight lbs.
-05	2.00	0.99	1.43	0.91	.26	500	1.2
-10	2.38	1.38	1.69	1.06	.31	1,000	1.5
-25	3.00	1.75	2.19	1.38	.40	2,500	3.0
-50	3.75	2.17	2.37	1.63	.37	5,000	5.0
-100	4.75	2.94	3.29	2.06	.61	10,000	11.0
-200	6.50	3.75	4.05	2.38	.84	20,000	24.0
-300						30,000	

*Torque rating is for continuous one direction of rotation. For reversing torque systems, the tabulated rating is the sum of the CW & CCW torque.

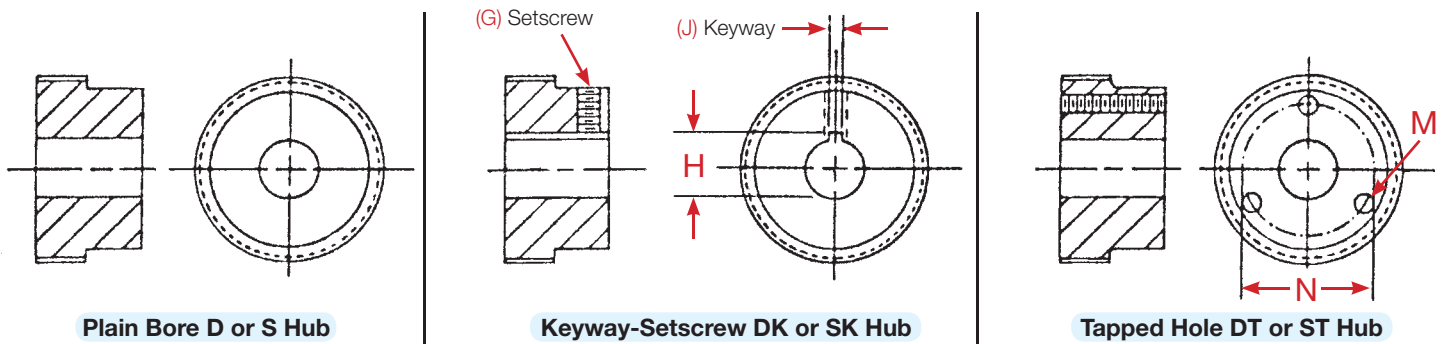

Basic HDI Size	Bore Size	D Hub		S Hub		G	H	J	D Hub		S Hub		M* UN-2B	N
		D Hub	S Hub	D Hub	S Hub				D Hub	S Hub	D Hub	S Hub		
-05	.250	2D	2S	2DK	2SK	8-32	—	—	2DT	2ST	6-32	.750	.750	
	.375	3D	3S	3DK	3SK	8-32	.409	.062	3DT	3ST	6-32	.750		
	.500	4D	4S	4DK	4SK	8-32	.561	.125	4DT	4ST	6-32	.750		
-10	.500	4D	4S	4DK	4SK	1/4-20	.585	.187	4DT	4ST	8-32	1.125	1.125	
	.625	5D	5S	5DK	5SK	1/4-20	.710	.187	5DT	5ST	8-32	1.125		
	.750	6D	6S	6DK	6SK	1/4-20	.837	.187	6DT	6ST	8-32	1.125		
-25	.750	6D	6S	6DK	6SK	1/4-20	.863	.250	6DT	6ST	10-32	1.500	1.500	
	.875	7D	7S	7DK	7SK	1/4-20	.988	.250	7DT	7ST	10-32	1.500		
	1.000	8D	8S	8DK	8SK	1/4-20	1.114	.250	8DT	8ST	10-32	1.500		
-50	1.000	8D	8S	8DK	8SK	1/4-20	1.114	.250	8DT	8ST	1/4-20	1.750	1.750	
	1.250	10D	10S	10DK	10SK	1/4-20	1.368	.250	10DT	10ST	1/4-20	1.750		
-100	1.250	10D	10S	10DK	10SK	3/8-16	1.418	.375	10DT	10ST	5/16-18	2.500	2.500	
	1.625	13D	13S	13DK	13SK	3/8-16	1.793	.375	13DT	13ST	5/16-18	2.500		
	1.750	14D	14S	14DK	14SK	3/8-16	1.918	.375	14DT	14ST	5/16-18	2.500		
-200	1.750	14D	14S	14DK	14SK	1/2-13	2.026	.625	14DT	14ST	3/8-16	3.125	3.125	
	2.000	16D	16S	16DK	16SK	1/2-13	2.276	.625	16DT	16ST	3/8-16	3.125		
	2.500	20D	20S	20DK	20SK	1/2-13	2.778	.625	20DT	20ST	3/8-16	3.125		

*Six holes equally spaced. True position .015 diameter except sizes -05 and -10 three holes. **To order:** specify the basic size and desired D and S hub configuration. Example: HDI 10-6D-6SK specifies a size -10 with D hub .750 diameter plain bore and S hub .750 diameter bore with keyway and setscrew.

Installation

Figure 1

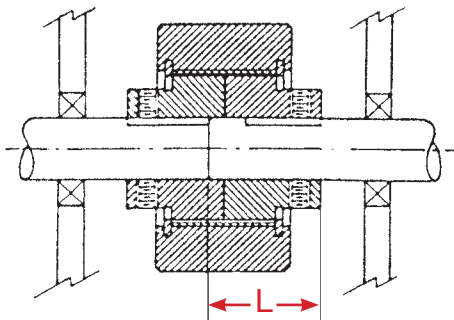

In-Line Shaft

HDI Size	L DIM
-05	.95
-10	1.09
-25	1.34
-50	1.43
-100	1.88
-200	2.25
-300	4.62

The Infit-Indexer can be installed in a machine system either as an in-line shaft coupling or a concentric shaft coupling.

In-Line Shaft (Fig. 1 & Fig. 2)

In order to properly align shafts concentric to one another, either the driven or driving shaft should pass completely through one hub and engage the other by an amount determined by the (L) dimension. The hubs are symmetrical; therefore, the (L) length applies to a piloting shaft length entering from either hub face.

The coupling is designed to transmit pure torque only. Radial reaction loads generated by gears, sprockets,

Figure 2

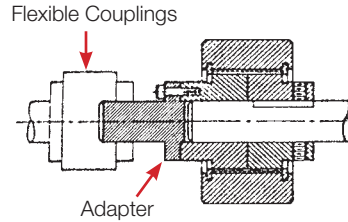

In-Line Shaft

Figure 3

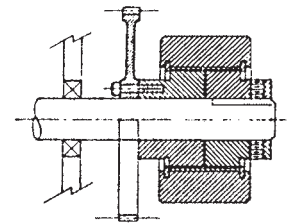

Concentric Shaft

shaft misalignment, etc., must be isolated from the unit by appropriate shaft bearing supports.

When it is not possible to maintain good shaft concentricity, it is recommended that the Infit-Indexer be mounted in conjunction with a flexible coupling and adapter as in Fig. 2.

Concentric Shaft (Fig. 3)

The shaft should pass completely through the attached sprocket, gear, etc., and the Infit-Indexer at a uniform diameter with a tight running fit.

It is recommended that the region of the shaft under the gear, sprocket, etc., and connected hub be lightly lubricated with a multi-purpose grease at assembly.

Adjusting Ring

One revolution of the knurled outer adjusting ring results in 3.6° of shaft phase adjustment. With the (D) hub fixed, rotation of the (S) hub is opposite to the direction of adjustment ring rotation. Conversely, with the (S) hub fixed, rotation at the (D) hub is in the same direction as adjusting ring rotation.

The coupling is essentially self-locking and applications requiring frequent adjustment can be investigated for the possibility of operating without having to seat the locking screw. However, those applications in which the coupling is subjected to typical motor start up accelerations, sudden stops and/or a vibratory environment will require use of the screw to maintain a phase setting.

The coupling during adjustment is not intended to drive against any significant reaction load that may exist between the connected shafts. However, some adjusting ring torque amplification results to provide a hub drive torque capability within recommended limits noted to below:

Unit Size	Adjusting Ring Torque (lb. in.) Ref.	Hub Drive Torque (lb. in.)
-05	4	20
-10	8	40
-25	16	80
-50	32	160
-100	76	380
-200	150	750
-300	340	1750

Spanner wrench holes are provided on the O.D. of the adjusting ring in sizes 50, 100, 200, and 300.

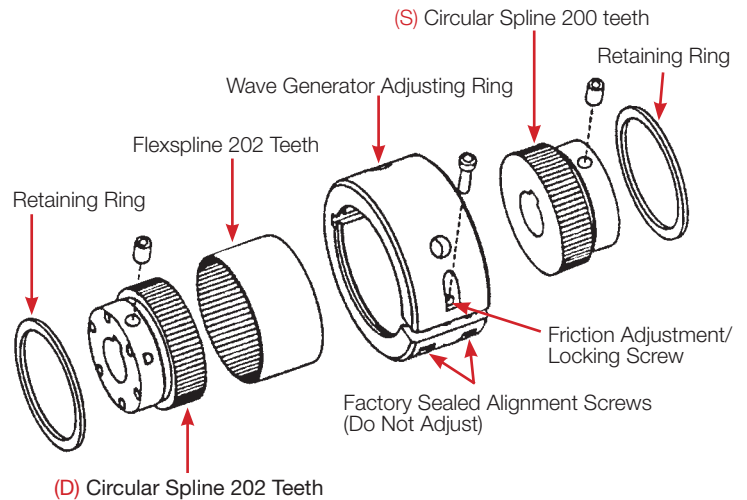

Lubrication and Disassembly

The coupling is factory lubricated and will not require further maintenance under normal conditions. Nevertheless, periodic maintenance should be performed when the coupling is subject to frequent adjustment, dirty or other abnormal conditions, or when the adjusting ring torque becomes higher than normal.

Loosen the adjusting ring locking screw (it is not necessary to remove the locking screw) and remove one retaining ring. All parts will then slide out in one direction. Do not tamper with or remove the two factory alignment screws. Clean the parts and re-lubricate with a multipurpose EP 2 (NLGI #2) grease, such as TEXACO Multifax EP 2. It is recommended that the region of the shaft under the gear, sprocket, etc., and connected hub (shown in figure 3) be lightly lubricated with the above type grease.

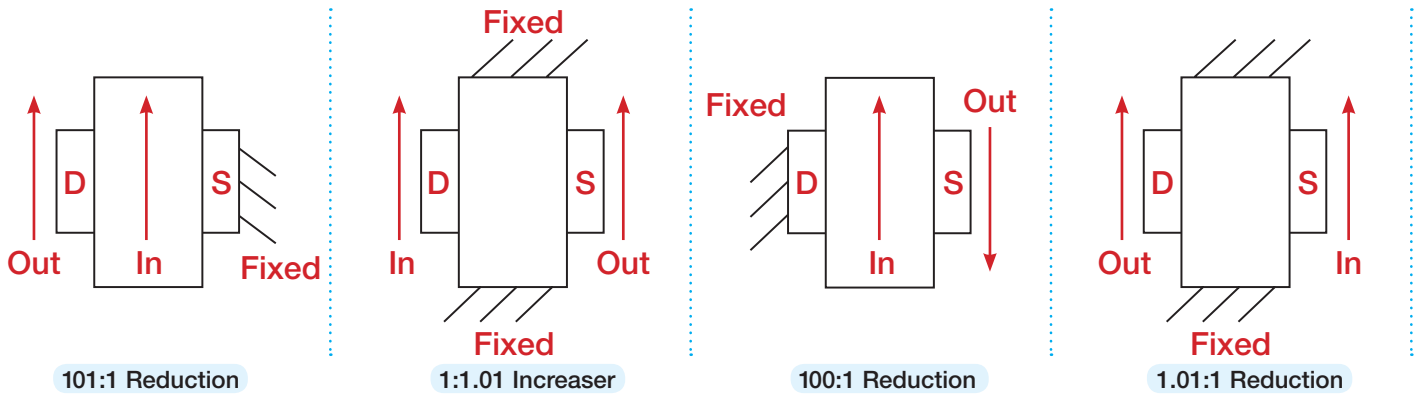

If any two elements are locked together, the indexer will not phase and the unit will rotate in a 1:1 mode.

Precise manual displacement of roll centerline to adjust nip-roll pressure or depth-of-cut using HDI Infnit-Indexer

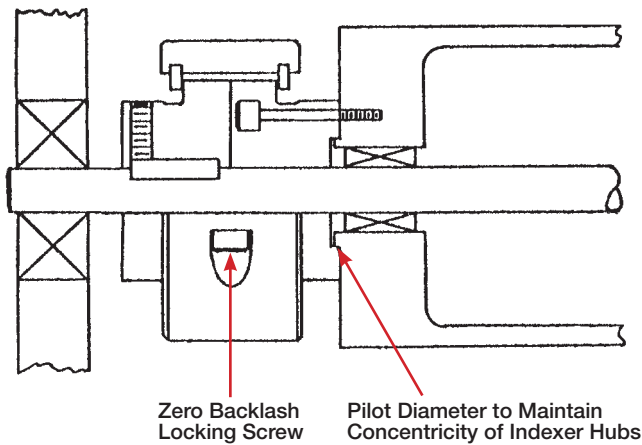
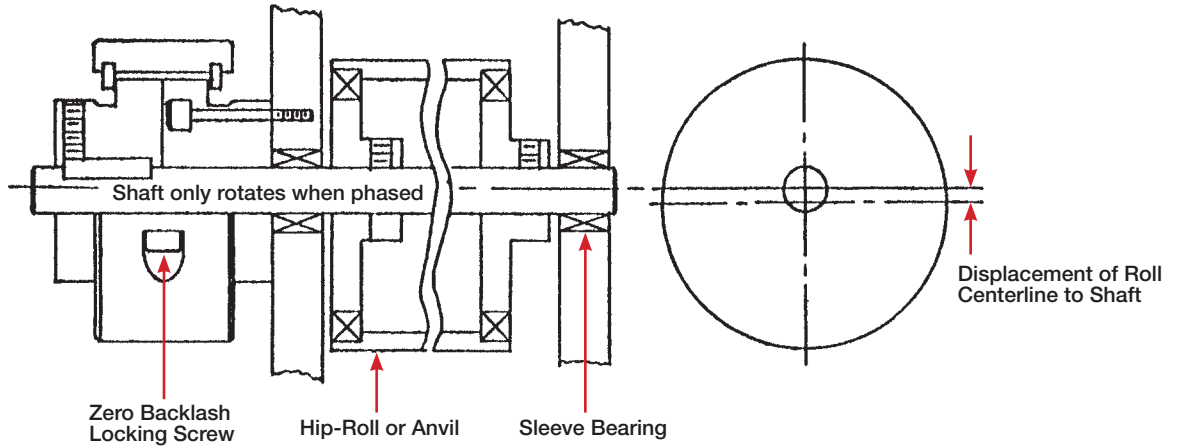

HDI Infnit-Indexer to manually phase a hollow roll to a solid through-shaft

HDI Infnit-Indexer for removal of backlash from a worm gear drive system. Two pinions, each mounted on the output shaft of separate, identical worm gear reducers, mate with a common bull gear. Adjusting the HDI causes one pinion to preload the bull gear against the other pinion. At set-up, the assembler finds the loosest mesh point of the system and adjusts-out the backlash at that point. Any other position of the bull gear will result in a preloaded system.

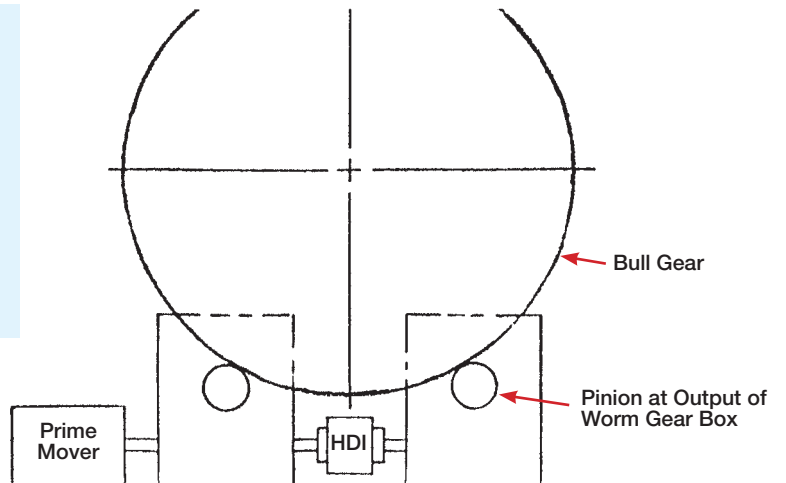

Infinet-Indexer Applications

The **Infinet-Indexer** provides the designer with a simple component which will solve an almost limitless variety of design problems through precise shaft phase adjustment.

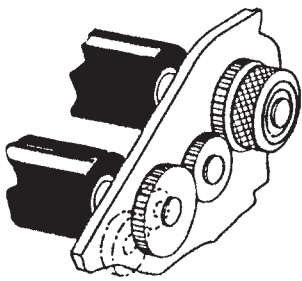

Adjusting Printing Rolls

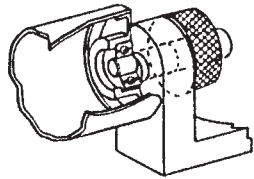

Adjusting an Eccentric

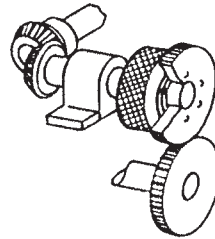

Phasing Gears

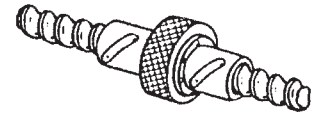

Adjustable Backlash on Ball Nuts

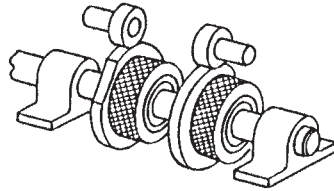

Phasing Cams

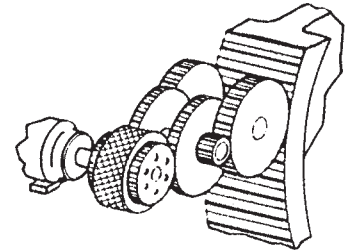

Adjusting a Dual Gear Train for Backlash Elimination

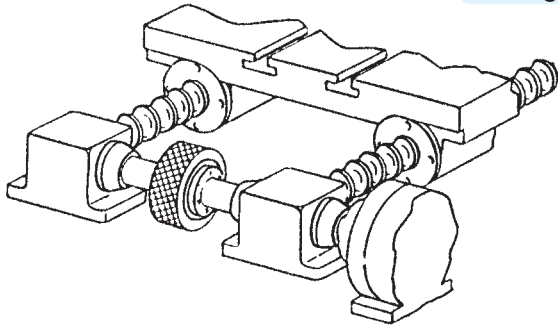

Aligning Part of a Machine Tool

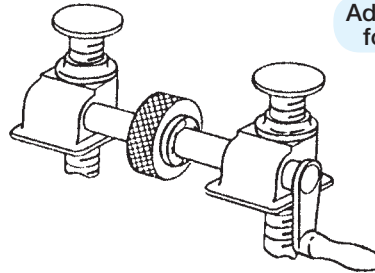

Aligning Leveling Jacks

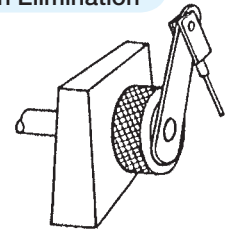

Adjusting Linkage

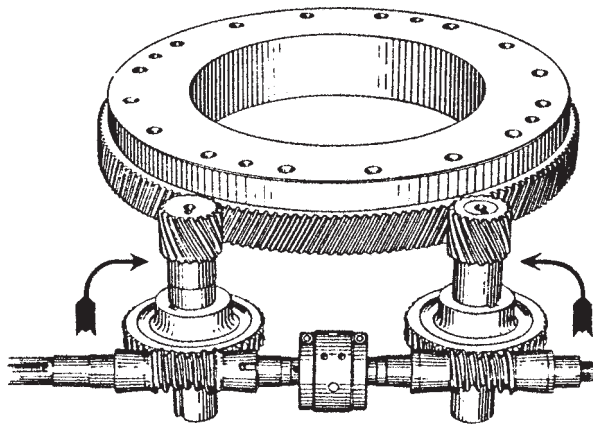

HDI-25-8DK-8SK

The rotary feed tables are driven by dual pinions which engage the ring gear. This unique design affords the ability to "take up" lost motion in the drive train and to actually preload the mechanism producing the "stiffness" necessary for rotary machining.

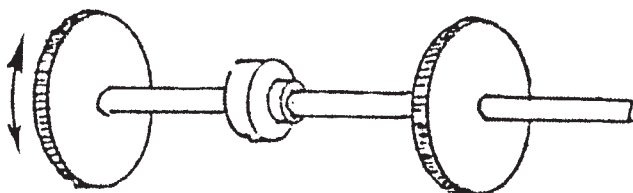

Aligning Teeth of Gears or Sprockets