

Speciális marók Sonder-Fräswerkzeuge Special milling cutters



LOSONCZI

Mérnöki, Szolgáltató és Kereskedelmi Kft.

H-5600 Békéscsaba, Kétegyházi út 3.

Tel.: 36 / 66-442-742 / -125 / -148

Fax: 36 / 66-442-720

www.losonczi.hu

Tárcsamaró D63x14 TNAX 1604ZZ lapkával
 Scheibenfräser D63x14 mit TNAX 1604ZZ Wendeschneidplatten
 Side and face cutter with TNAX 1604ZZ inserts

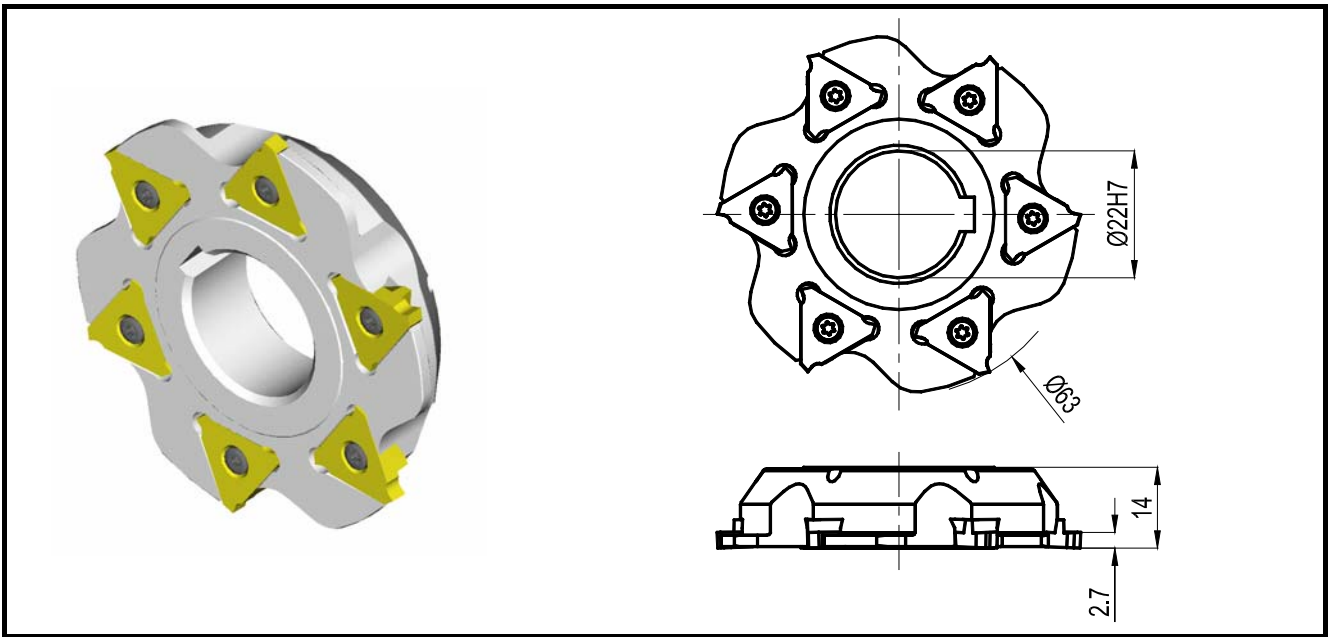

Élletörő maró 45°/15° CNHQ 1005R08 lapkával
 Fräser für Abfasen 45°/15° mit CNHQ 1005R08 Wendeschneidplatten
 Chamfering cutter 45°/15° with CNHQ 1005R08 inserts

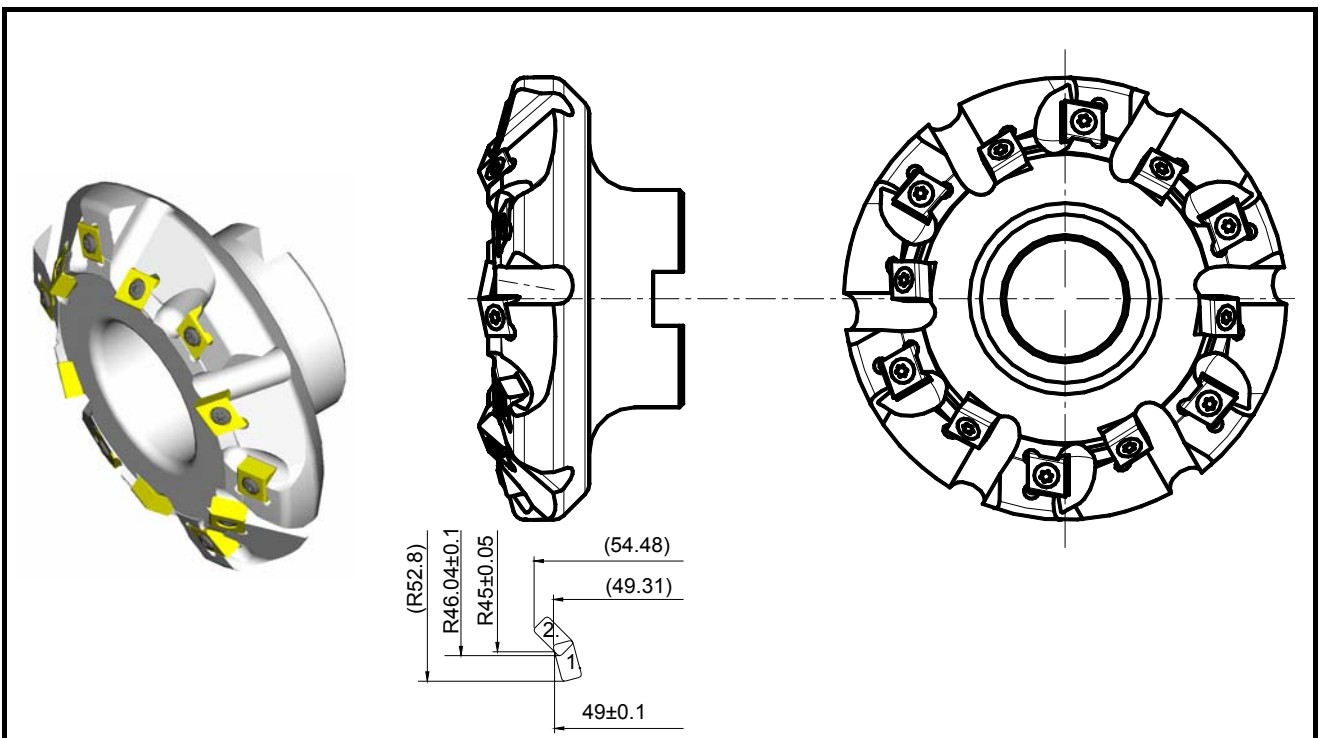

Tárcsamaró D215 balos
Scheibenfräser D215 Linksausführung
Side and face cutter D215 left hand

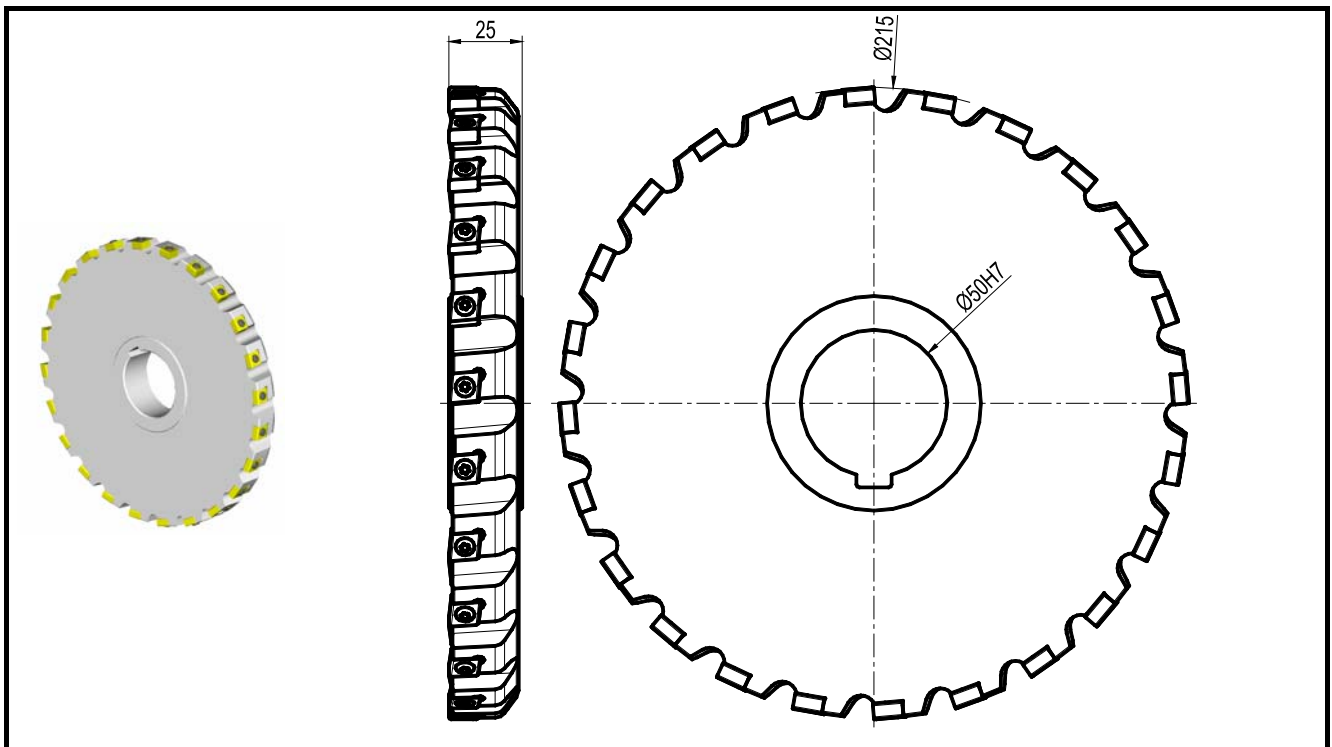

Speciális sünmaró DIN 2080 SK40 x D40 / 72°
Sonder-Igelfräser DIN 2080 SK40 x D40 / 72°
Special long edge cutter DIN 2080 SK40xD40/72°

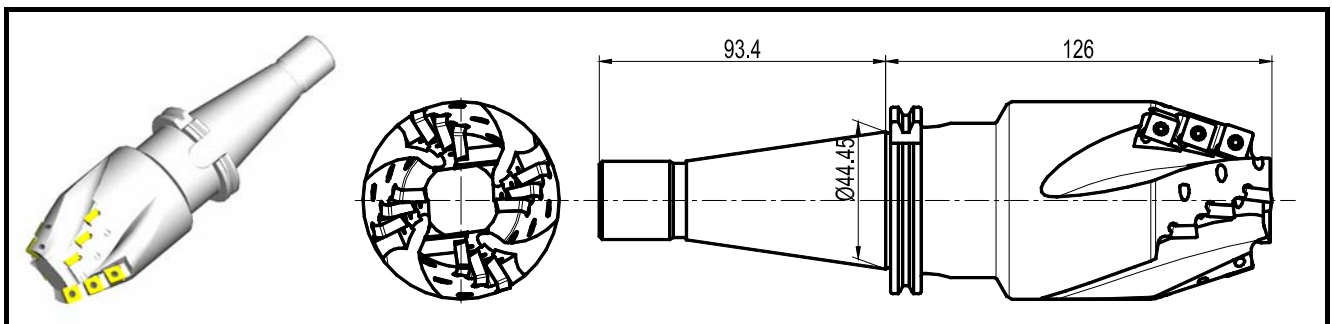

Sünmaró APK D26-MK3-FE APKT 1003PDR lapkával
Igelfräser APK D26-MK3-FE mit APKT 1003PDR Wendeschneidplatten
Long edge cutter APK D26-MK3-FE with APKT 1003PDR inserts

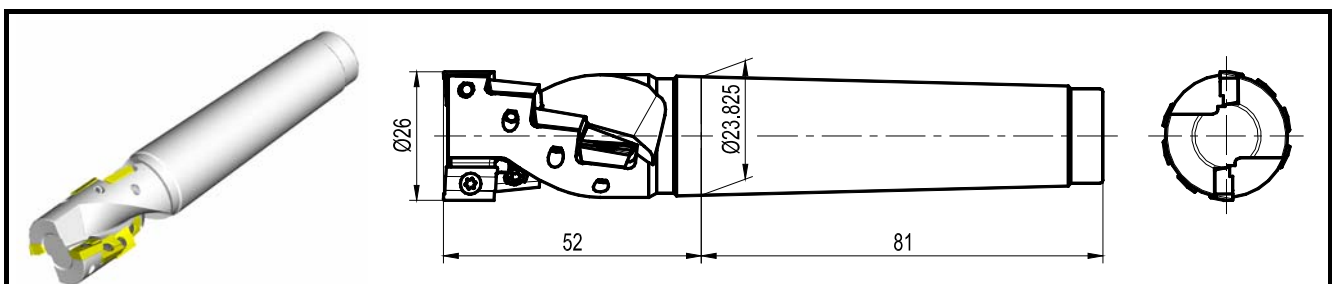

Speciális alakmaró R25
 Sonder-Profilfräser R25
 Special profile milling cutter

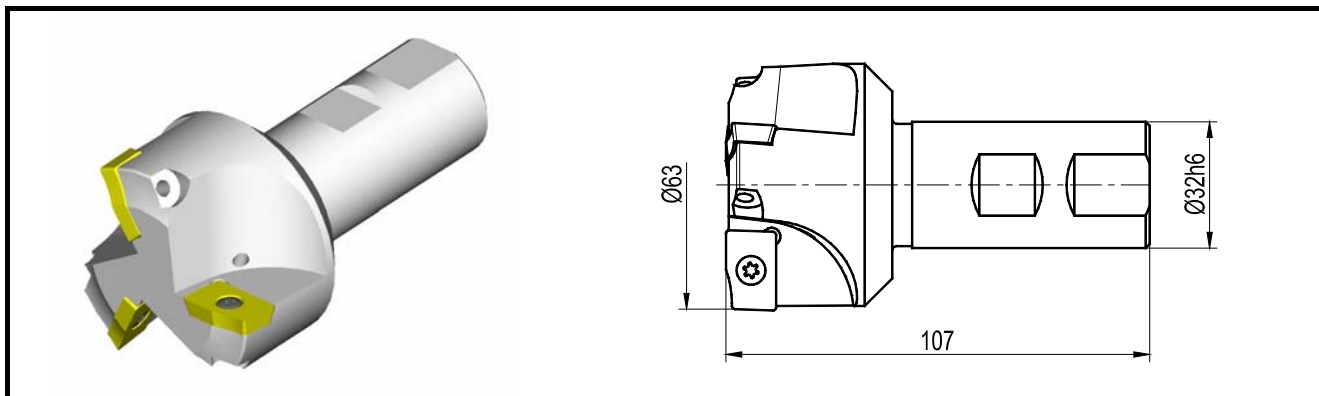

Élletörő maró D50 / 65°
 Fräser für Abfasen D50 / 65°
 Chamfering cutter D50/65°

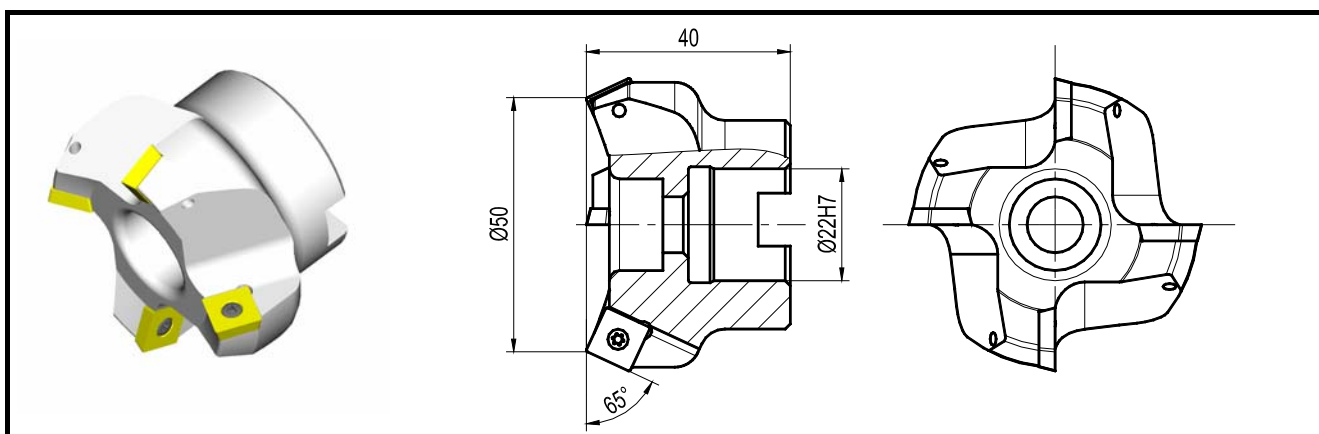

Szögmaró D80 / 46° LDFT 150408 lapkával
 Winkelfräser D80 / 46° mit LDFT 150408 Wendeschneidplatten
 Milling cutter D80/46° with LDFT 150408 inserts

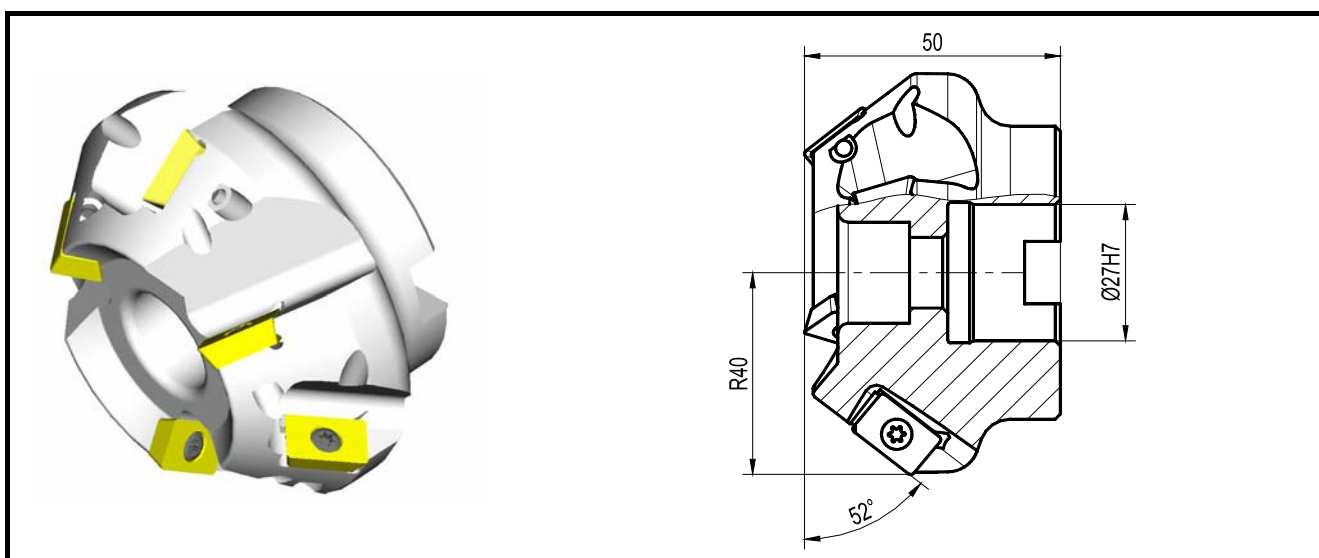

Síkmaró D100 / 75° APGW 15T3 lapkával
 Planfräser D100 / 75° mit APGW 15T3 Wendeschneidplatten
 Face milling cutter D100/75° with APGW 15T3 inserts

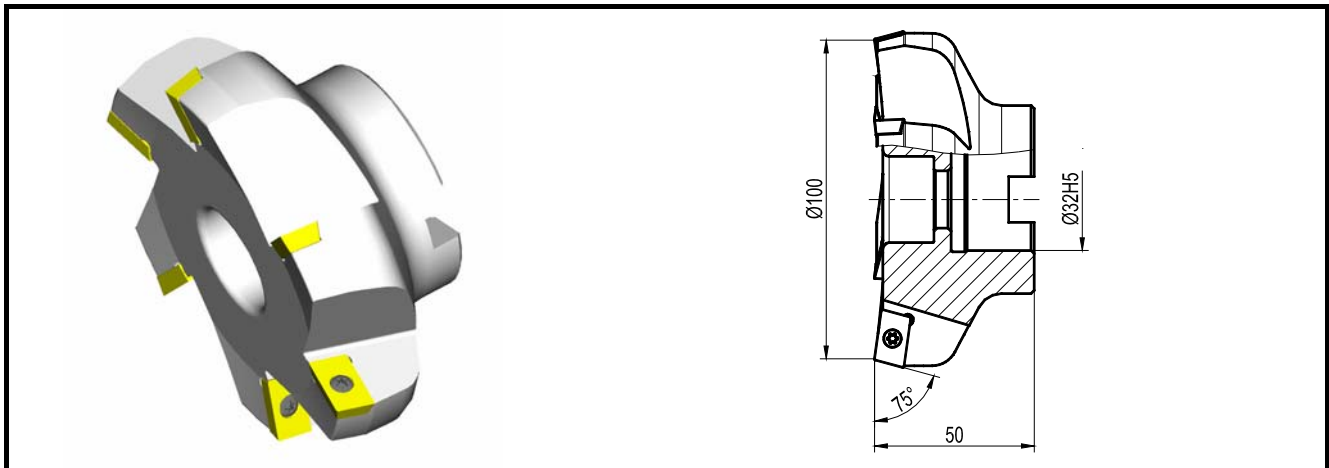

UIC54 hevederkamramaró D140
 Profilfräser UIC54 D140 für Eisenbahnweichen-Bearbeitung
 Profile milling cutter type UIC 54 D140

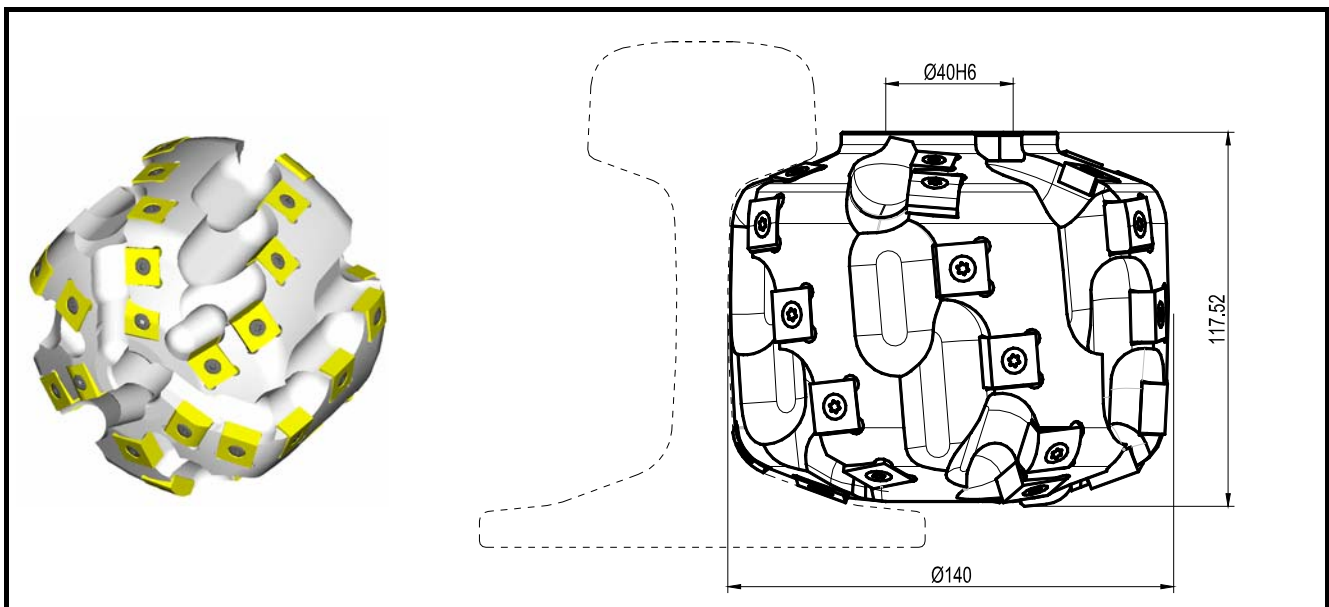

Sarokmaró B25 x D30 / L49 XOMX 060202R lapkával
 Schafffräser B25 x D30 / L49 mit XOMX 060202R Wendeschneidplatten
 Shoulder milling cutter B25xD30/L49 with XOMX 060202R inserts

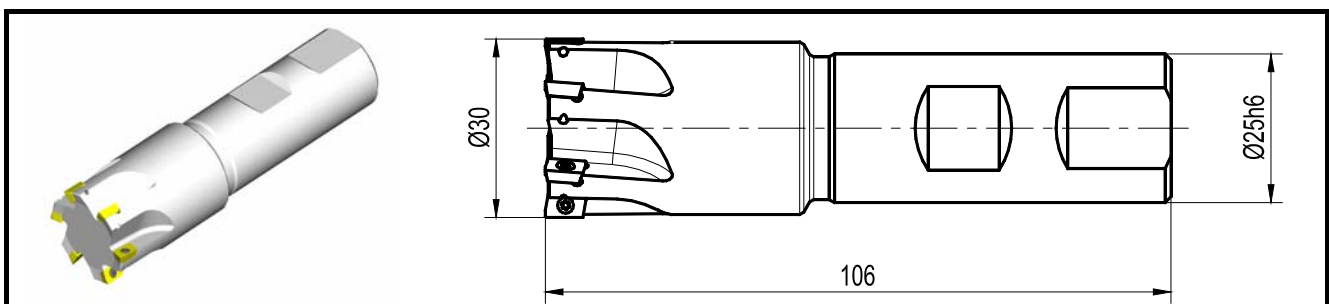

Gömbmaró D50
Radiusfräser D50
Ball point cutter D50

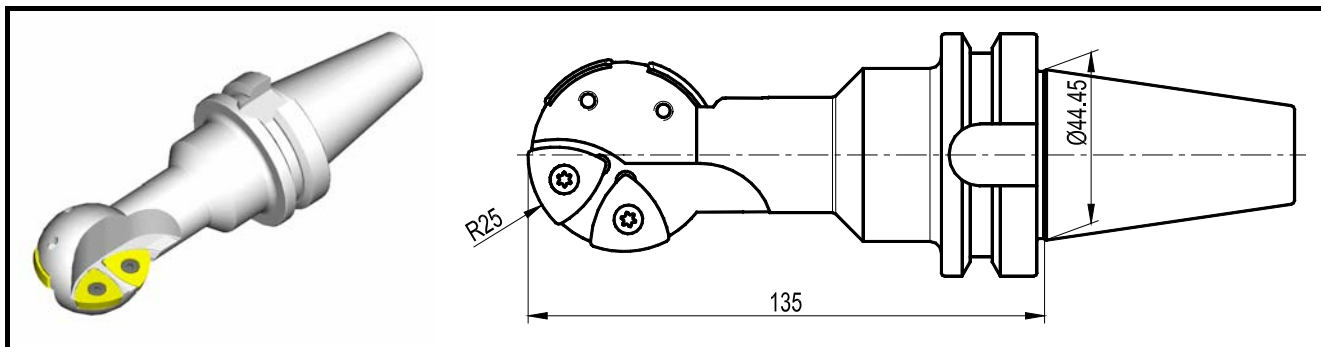

Sünmaró DIN 2080 SK50 / D100 L190
Igelfräser DIN 2080 SK50 / D100 L190
Long edge cutter DIN 2080 SK50/D100/L190

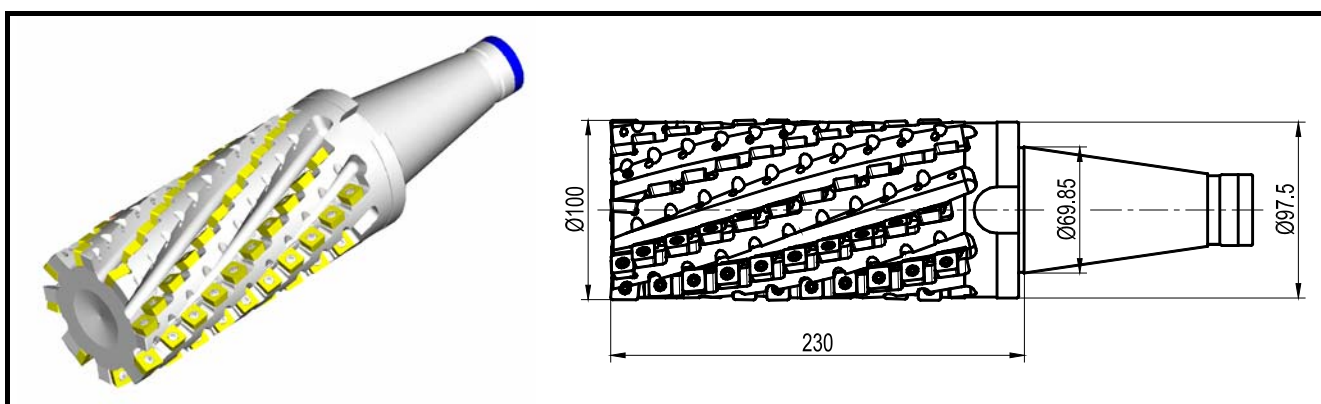

Speciális kúpos maró D155 / 1:20
Sonder-Winkelfräser D155 / 1:20
Special taper cutter D155/1:20

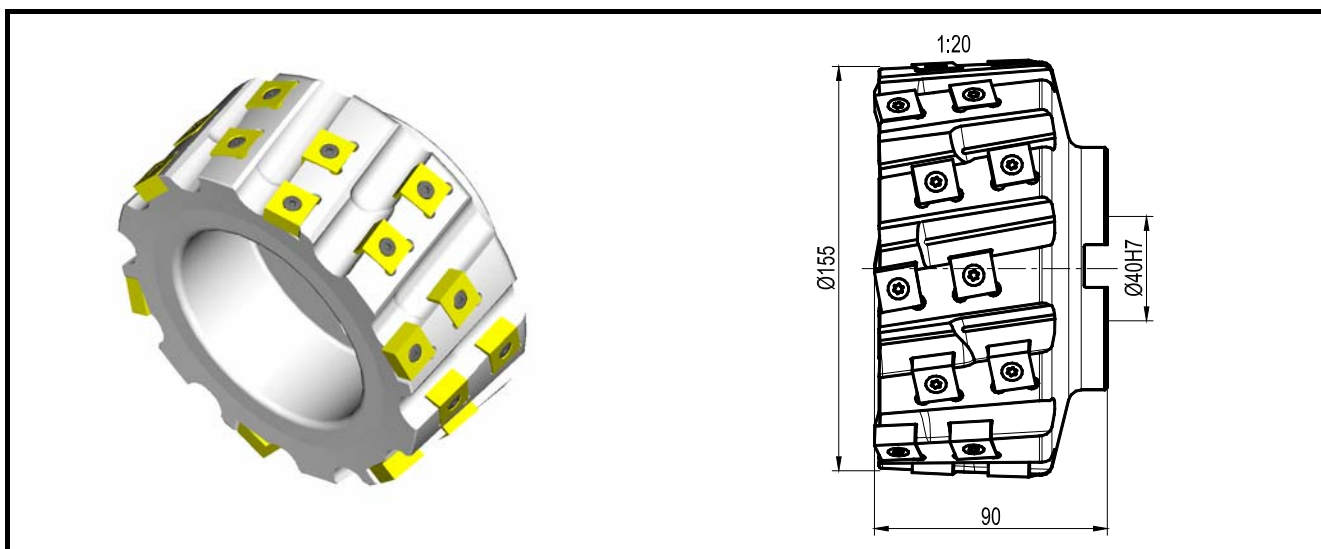

1. Lapkatípus – Wendeschneidplatten-Typ – Type of the insert

2. Belső hűtés – Innenkühlung – Internal cooling

 Igen/Nem – Ja/Nein – Yes/No

3. Forgásirány – Drehrichtung - Sense of rotation

 Jobbos/Balos – Rechts/Links – Left hand/Right hand

4. Befogás típusa – Befestigungsart – Type of coupling

(WELDON, ...)

5. Kiegyensúlyozás – Auswuchten – Balancing

 Igen/Nem – Ja/Nein – Yes/No

G: Fordulatszám – Umdrehungen - Speed /min

6. Fogszám – Zähnenzahl – Number of teeth

Z:

7. Vázlat– Skizze – Sketch