

Backlash-free Metal Bellow Couplings

You Can Rely On Us!

GERWAH



GERWAH®

GERWAH The Company

Gerwah GmbH was founded in 1980. The idea of new, innovative products has made Gerwah a recognized partner in the machine tool industry. We are a dynamic, spirited and fast growing company with clear goals and open mind that is reflected in the architecture of our new headquarters.

Our Goals

- To add value for our customers by providing innovative product solutions
- To develop solutions in cooperation with our customers
- Satisfied customers

Our Advantages

- Know-how, innovative designs and cutting edge manufacturing plants
- Customer oriented employees
- Technical assistance and service, both locally and internationally
- Qualified sales force
- Economic stability
- Worldwide presence with subsidiaries and dealers



Our new headquarters in Grosswallstadt, Germany



GERWAH - You Can Rely On Us!

We are certified according to DIN EN ISO 9001:2000 (Cert.-No. 0063-D)

GERWAH®

Backlash-free Metal Bellow Couplings Series

Applications: Backlash-free metal bellow couplings are used in the area of the machine tool industry, where a torque or a rotary motion has to be transmitted from shaft to shaft in highest accuracy of angle:

- Pumps with axial and vertical drives
- High dynamic portal drives
- Spindle lifting units
- Linear units
- Packaging machines
- Machine tools
- Special machines



EKN
Metal bellow coupling with radial set screws; 0,4-10 Nm
Technical data page 4



DKN
Metal bellow coupling with clamping hubs; 0,4-10 Nm
Technical data page 5



AKN
Metal bellow coupling with clamping hubs and shorter length; 18-500 Nm
Technical data page 6



AKD
Metal bellow coupling with clamping hubs; 18-500 Nm
Technical data page 7



AK
Metal bellow coupling with inner conical hub; 30-5000 Nm
Technical data page 8



AK/SB
Metal bellow coupling with outer conical hub; 18-5000 Nm
Technical data page 9



S-Line
Metal bellow coupling w. pluggable clamping hub; 2-150 Nm
Technical data page 10



CK
Metal bellow Coupling with flange; 18-5000 Nm
Technical data page 11

Characteristics of the metal bellow couplings

- Backlash-free transmission of torque
- High torsional stiffness, precision of transmission of rotational angle
- Different torsional stiffness
- Backlash-free shaft connection
- Small dimensions, low moment of inertia
- Metal bellow made of stainless steel
- Simple and operationally safe assembly
- Compensation for radial, axial and angular misalignment
- Free of wear, maintenance-free, no standstill period
- Not sensitive to temperatures between -30°C and +100°C, higher temperature ranges available on request
- Economical and friendly due to modular system
- Nominal moments between 0,1 – 5000 Nm

The details in this catalogue describe the products and do not represent guaranteed qualities. The user is responsible for checking and

defining the technical characteristics of his particular application. We reserve the right to make changes at any time without notice. We

cannot be held responsible for any omissions or printing errors. Deliveries are based on individual detailed contractual agreements.

GERWAH®

Backlash-free Metal Bellow Coupling Series EKN miniature

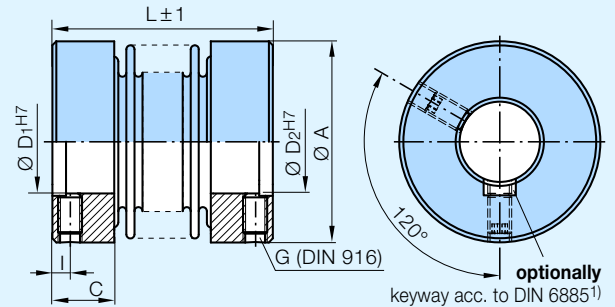

Technical data series EKN

Type			4	9	15	20	45	100
Nominal torque (Nm)	T_{KN}		0,4	0,9	1,5	2	4,5	10
Misalignment (mm)	radial ΔK_r		0,1 / 0,15 / 0,2	0,1 / 0,15 / 0,2	0,1 / 0,15	0,1 / 0,2 / 0,25	0,1 / 0,2	0,15 / 0,25
	axial ΔK_a		0,2 / 0,3 / 0,4	0,2 / 0,3 / 0,4	0,25 / 0,4	0,3 / 0,4 / 0,5	0,3 / 0,5	0,4 / 0,5
	angular ΔK_w (degree)		1,2/2	1,2/2	1,2/2	1,2/2	1,2/2	1,2/2
Torsional stiffness (Nm/rad)	$C_{T_{dyn}}$		250/190/150	500/380/300	750 / 700	1500/1300/1000	6500 / 4000	8100 / 6700
Moment of inertia (g cm ²)	J		2,0	2,0 / 2,3 / 2,6	7,5 / 8	14 / 16 / 17	68 / 73	200 / 220
Tightening torque of the retaining screws (Ncm)	M_A		50	50	150	50	300	300
Weight (g)	m		6	6 / 7 / 8	17 / 19	22 / 24 / 26	54 / 58	104 / 114

Dimensions series EKN

Type			4	9	15	20	45	100
Ø A (mm)	max.		15	15	20	25	32	40
C (mm)			6	6	8	8	12	12
L (mm)	±1		20 / 23 / 26	21 / 25 / 28	25 / 30	27 / 33 / 37	39 / 48	44 / 54
D ₁ /D ₂ (mm)	H7 min. - max.		3-8	3-8	3-10	3-12	6-16	6-19
G (DIN 916)			M3	M3	2xM4	2xM3	2xM6	2xM6
l (mm)			2	2	3	2,2	4	4

Hub bores Standard quality of fitting H7
Custom bores on request

Standard bores EKN 4-15 Ø 6H7
EKN 20 Ø 6H7 and 10H7
EKN 45-100 Ø 10H7

Materials Hubs made of aluminium
Metal bellow made of stainless steel
Stainless steel version also available

Rotational speed 15.000 min⁻¹

1) Tolerance of keyway; standard JS9

Ordering data	EKN 20/27 - 6,35^{H7} - 10^{H7} - xxx
	Type length
	Bore diameter D ₁
	Bore diameter D ₂
	Further details e.g. material, keyway

GERWAH®

Backlash-free Metal Bellow Coupling Series DKN miniature

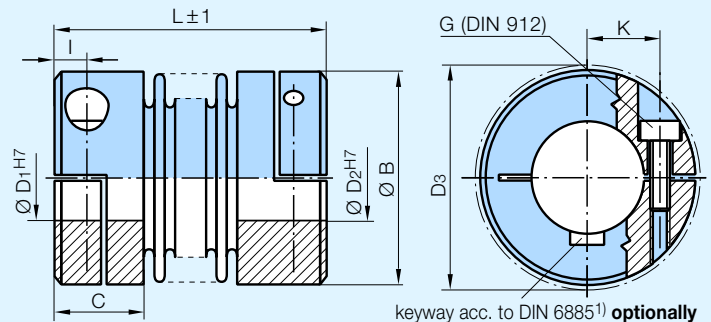

Technical data series DKN

Type		4	9	15	20	45	100
Nominal torque (Nm)	T_{KN}	0,4	0,9	1,5	2	4,5	10
Misalignment (mm)	radial ΔK_r	0,1 / 0,15 / 0,2	0,1 / 0,15 / 0,2	0,1 / 0,15	0,1 / 0,2 / 0,25	0,1 / 0,2	0,15 / 0,25
	axial ΔK_a	0,2 / 0,3 / 0,4	0,2 / 0,3 / 0,4	0,25 / 0,4	0,3 / 0,4 / 0,5	0,3 / 0,5	0,4 / 0,5
	angular ΔK_w (degree)	1,2/2	1,2/2	1,2/2	1,2/2	1,2/2	1,2/2
Torsional stiffness (Nm/rad)	$C_{T_{dyn}}$	250 / 190 / 150	500 / 380 / 300	750 / 700	1500/1300/1000	6500 / 4000	8100 / 6700
Moment of inertia (g cm ²)	J	2,6	2,6 / 2,9 / 3,2	11/ 12	25 / 27 / 28	98 / 103	231 / 250
Tightening torque of the retaining screws (Ncm)	M_A	30	30	80	100	300	300
Weight (g)	m	9	9 / 10 / 11	22 / 24	36 / 38 / 40	74 / 78	120 / 130

Dimensions series DKN

Type		4	9	15	20	45	100
$\varnothing B$	(mm)	15,5	15,5	20	25	32,5	40,5
C	(mm)	7	7	9	12	14	14,5
L	(mm) ± 1	21 / 24 / 28	23 / 26 / 30	26 / 30	32 / 38 / 42	41 / 50	47 / 57
l	(mm)	2,4	2,4	3	3,5	4,5	5
D_1/D_2	(mm) H7 min. - max.	3-6,5	3-6,5	3-10	3-12	6-16	6-19
D_3	(mm) Clearance diameter	17,5	17,5	21	27	34	41,5
G	(DIN 912) 8.8	M2	M2	M2,5	M3	M4	M4
K	(mm)	5,6	5,6	7	9	11,5	15,5

Hub bores Standard quality of fitting H7
Custom bores on request

Standard bores DKN 4-15 \varnothing 6H7
DKN 20 \varnothing 6H7 and 10H7
DKN 45-100 \varnothing 10H7

Materials Hubs made of aluminium
Metal bellow made of stainless steel
Stainless steel version also available

Rotational speed 15.000 min⁻¹

1) Tolerance of keyway; standard JS9

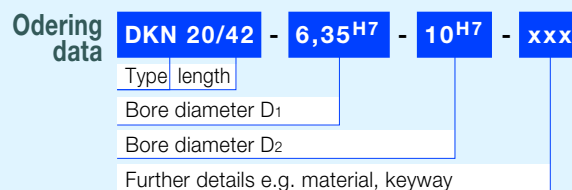

GERWAH

Backlash-free Metal Bellow Coupling Series AKN

with increased torsional stiffness with clamping hub

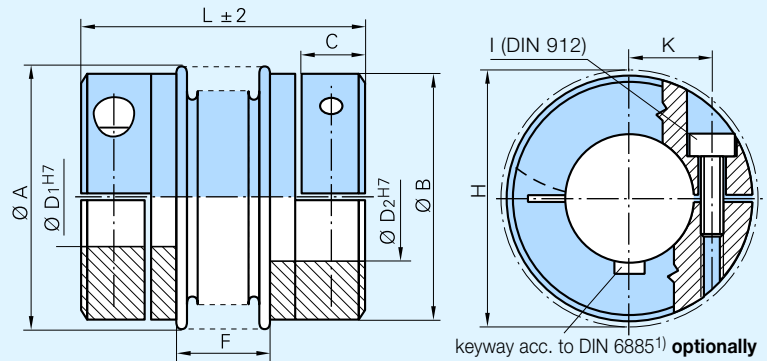

Technical data series AKN

Type	18	30	60	80	150	200	300	500
Nominal torque (Nm) T_{KN}	18	30	60	80	150	200	300	500
Torsional stiffness (10^3 Nm/rad) C_{Tdyn}	8	35	75	130	150	170	500	680
Radial spring stiffness (N/mm) C_r	200	720	1100	1200	2000	2500	6300	8800
Axial spring stiffness (N/mm) C_a	50	50	90	80	150	150	280	100
Moment of inertia (10^{-3} Kgm ²) J	0,08	0,1/0,16	0,3/0,5	1,4/2,3/2,8	1,4/2,3/2,8	2,6/4,2	4,6/6,2	9
Tightening torque of the retaining screws (Nm) M_A	6	15/12	40/30	60/55/50	80/70/50	100/80	110/90	145
Weight (approx. kg) m	0,2	0,2/0,3	0,5/0,6	1,7/2,1/2,3	1,7/2,1/2,3	2,5/3,3	3,4/4,1	4,8
Max. approved misalignment (mm) radial ΔK_r	0,2	0,1	0,1	0,2	0,2	0,2	0,2	0,2
(mm) axial ΔK_a	0,5	0,4	0,4	0,4	0,4	0,4	0,4	0,5
(degree) angular ΔK_w	1,5	1	1	1	1	1	1	1
Max. rotating speed at $V=30$ m/s (min^{-1}) n_{max}	12700	10200	8600	6800	6800	6300	5900	4900

Dimensions series AKN

Type	18	30	60	80	150	200	300	500
L (mm) ± 2	63	65	78	91	91	100	102	110
$\varnothing A$ (mm) max.	46	56	66	83	83	90	110	122
$\varnothing B$ (mm)	45	47/56	57/66	76/80/84	76/80/84	80/90	91/96	110
C (mm)	12	15	19,5	21,5	21,5	25,5	26	29,5
D_1^{H7}/D_2^{H7-2} (mm) min.	10	10/20	14/23	20/28/35	20/28/35	25/32	32/40	40
(mm) max.	25	20/25	23/35	28/35/40	28/35/40	32/42	40/45	60
F (mm)	24	16	20	24	24	24	27	28
I (mm)	M5	M6	M8	M10	M10	M12	M12	M12
K (mm)	17,5	16/20	20/24	24/27/28	24/27/28	26/31	32/35	40
H (mm) Clearance diameter	48	56	70	84	84	93	102	115

Hubs 18 - 60 made of aluminium, hubs 80 - 500 made of steel; other materials available on request

- 1) Tolerance of keyway; standard JS9
- 2) Smaller diameters possible for lower torque of transmission
- 3) Stainless steel version also available

Ordering data

AKN 150 - 30^{H7} - 35^{H7} - xxx

Type

Bore diameter D_1

Bore diameter D_2

Further details e.g. material, keyway

GERWAH®

Backlash-free Metal Bellow Coupling Series AKD

with clamping hub

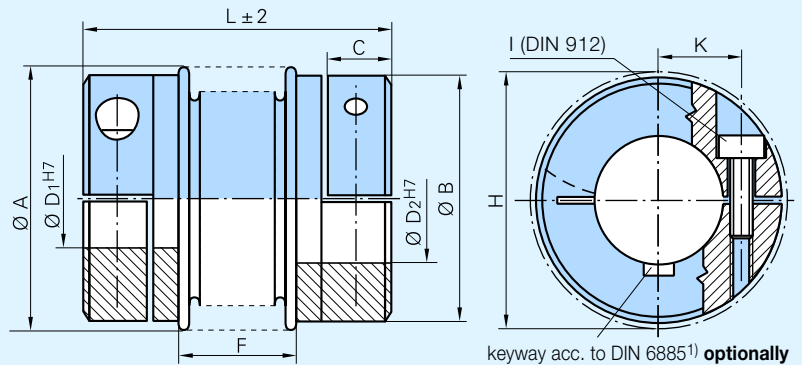

Technical data series AKD

Type	18	30	60	80	150	200	300	500
Nominal torque (Nm) T_{KN}	18	30	60	80	150	200	300	500
Torsional stiffness (10^3 Nm/rad) C_{Tdyn}	6	25	50	75	100	120	280	310
Radial spring stiffness (N/mm) C_r	85	220	330	400	600	450	1500	1000
Axial spring stiffness (N/mm) C_a	40	30	55	55	85	85	150	85
Moment of inertia (10^{-3} Kgm ²) J	0,08	0,1/0,16	0,3/0,5	1,4/2,3/2,8	1,4/2,3/2,8	2,6/4,2	4,6/6,2	9
Tightening torque of the retaining screws (Nm) M_A	6	15/12	40/30	60/55/50	80/70/50	100/80	110/90	145
Weight (approx. kg) m	0,2	0,2/0,3	0,5/0,6	1,7/2,1/2,3	1,7/2,1/2,3	2,5/3,3	3,4/4,1	4,9
Max. approved misalignment	(mm) radial ΔK_r	0,2	0,2	0,2	0,2	0,2	0,2	0,2
	(mm) axial ΔK_a	0,5	0,5	0,5	0,5	0,5	0,5	1
	(degree) angular ΔK_w	1,5	1,5	1,5	1,5	1,5	1,5	1,5
Max. rotating speed at $V=30$ m/s (min^{-1}) n_{max}	12700	10200	8600	6800	6800	6300	5900	4900

Dimensions series AKD

Type	18	30	60	80	150	200	300	500
L (mm) ± 2	71	73	88	103	104	113	115	122
$\varnothing A$ (mm) max.	46	56	66	83	83	90	110	122
$\varnothing B$ (mm)	45	47/56	57/66	76/80/84	76/80/84	80/90	91/96	110
C (mm)	12	15	19,5	21,5	21,5	25,5	26	29,5
$D_1^{H7}/D_2^{H7 \ 2)}$ (mm) min.	10	10/20	14/23	20/28/35	20/28/35	25/32	32/40	40
	(mm) max.	25	20/25	23/35	28/35/40	28/35/40	32/42	40/45
F (mm)	32	24	31	35	36	37	40	40
I	M5	M6	M8	M10	M10	M12	M12	M12
K (mm)	17,5	16/20	20/24	24/27/28	24/27/28	26/31	32/35	40
H (mm) Clearance diameter	48	56	70	84	84	93	102	115

Hubs 18 - 60 made of aluminium, hubs 80 - 500 made of steel; other materials available on request

- 1) Tolerance of keyway; standard JS9
- 2) Smaller diameters possible for lower torque of transmission
- 3) Stainless steel version also available

Ordering data **AKD 150** - **30^{H7}** - **35^{H7}** - **xxx**

Type

Bore diameter D_1

Bore diameter D_2

Further details e.g. material, keyway

GERWAH®

Backlash-free Metal Bellow Coupling Series AK with conical hub

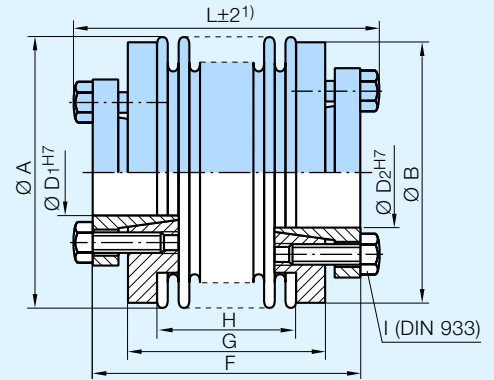

Technical data series AK

Type		30	60	80	150	200	300	500	800	1400	3000	5000
Nominal torque (Nm) T_{KN}		30	60	80	150	200	300	500	800	1400	3000	5000
Torsional stiffness (10^3 Nm/rad) C_{Tdyn}		35/25	75/50	130/75	150/100	170/120	500/280	310	760	1300	2800	4800
Radial spring stiffness (N/mm) C_r		720/220	1100/330	1200/400	2000/600	2500/450	6300/1500	1000	510	710	2950	4920
Axial spring stiffness (N/mm) C_a		50/30	90/55	80/55	150/85	150/85	280/150	85	190	280	310	510
Moment of inertia (10^{-3} Kgm ²) J		0,15	0,4	0,8	0,8	1,5	4	7,2	26,1	26,1	48	62
Tightening torque of the retaining screws (Nm) M_A		3,0	8,5	10	14	14	18	26	45	80	85	210
Weight (approx. kg) m		0,4	0,8	1,3	1,3	1,6	3,4	4,2	8,5	8,5	15	21
Max. approved misalignment	(mm) radial ΔK_r	0,1/0,2	0,1/0,2	0,2/0,2	0,2/0,2	0,2/0,2	0,2/0,2	0,2	0,2	0,2	0,2	0,2
	(mm) axial ΔK_a	0,4/0,5	0,4/0,5	0,4/0,5	0,4/0,5	0,4/0,5	0,4/0,5	1,0	1,0	1,0	1,0	1,0
	(degree) angular ΔK_w	1,0/1,5	1,0/1,5	1,0/1,5	1,0/1,5	1,0/1,5	1,0/1,5	1,5	1,5	1,5	1,5	1,5
Max. rotating speed at $V=30$ m/s (min^{-1}) n_{max}		11000	9100	7000	7000	6700	5200	4600	3700	3700	2800	2800

Dimensions series AK

Type		30	60	80	150	200	300	500	800	1400	3000	5000
L (mm) ± 2		52/60	63/73	80/91	80/92	80/93	91/104	113	170	170	206	206
$\varnothing A$ (mm) max.		56	66	82	82	90	110	122	157	157	157	208
$\varnothing B$ (mm)		52	63	80	80	85	110	122	152	152	152	190
D_1^{H7}/D_2^{H7} (mm)	min.	12	15	20	20	20	25	35	50	50	70	60
	max.	20	25	35	35	40	50	55	70 ²⁾	70 ²⁾	80 ²⁾	85 ²⁾
F (mm)		45/53	55/65	72/83	72/84	72/85	80/93	102	150	150	190	186
G (mm)		29/37	37/47	50/61	50/62	50/63	54/67	72	110	110	150	146
H (mm)		16/24	21/31	24/36	24/36	25/37	29/40	40	84	84	84	94
I (DIN 933)		6xM4	6xM6	6xM6	6xM6	6xM6	6xM8	6xM8	6xM16	6xM16	6xM12	6xM16

- 1) Keep space for the releasing screws
- 2) Larger bores on request
- 3) Stainless steel version also available

Ordering data **AK 150/80** - **30^{H7}** - **35^{H7}** - **xxx**

Type length

Bore diameter D_1

Bore diameter D_2

Further details e.g. material, keyway

GERWAH®

Backlash-free Metal Bellow Coupling Series AK/SB

with outer conical hub

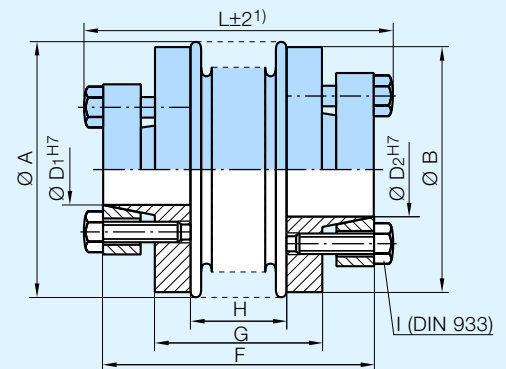

Technical data series AK/SB

Type	18	30	60	150	200	300	500	800	1400	3000	5000
Nominal torque (Nm) T_{KN}	18	30	60	150	200	300	500	800	1400	3000	5000
Torsional stiffness (10^3 Nm/rad) C_{Tdyn}	8/6	35/25	75/50	150/100	170/120	500/280	310	760	1300	2800	4800
Radial spring stiffness (N/mm) C_r	200/85	720/220	1100/330	2000/600	2500/450	6300/1500	1000	510	710	2950	4920
Axial spring stiffness (N/mm) C_a	50/40	50/30	90/55	150/85	150/85	280/150	85	190	280	310	510
Moment of inertia (10^{-3} Kgm ²) J	0,1	0,5	0,4	0,8	1,5	4	14	48	48	54	136
Tightening torque of the retaining screws (Nm) M_A	5,9	5,9	8,7	15	15	25	36	85	115	125	210
Weight (approx. kg) m	0,3	0,4	1,8	1,3	1,6	3,4	4	7,5	7,5	16	27
Max. approved misalignment	(mm) radial ΔK_r	0,1/0,2	0,1/0,2	0,2/0,2	0,2/0,2	0,2/0,2	0,2	0,2	0,2	0,2	0,2
	(mm) axial ΔK_a	0,4/0,5	0,4/0,5	0,4/0,5	0,4/0,5	0,4/0,5	1,0	1,0	1,0	1,0	1,0
	(degree) angular ΔK_w	1,0/1,5	1,0/1,5	1,0/1,5	1,0/1,5	1,0/1,5	1,5	1,5	1,5	1,5	1,5
Max. rotating speed at $V=30$ m/s (min^{-1}) n_{max}	12700	11000	9100	7000	6700	5200	4600	3700	3700	2800	2800

Dimensions series AK/SB

Type	18	30	60	150	200	300	500	800	1400	3000	5000
L (mm) ± 2	65/73	60/68	80/90	98/110	98/110	111/122	135	180	180	220	245
Ø A (mm) max.	45	56	66	82	90	110	122	157	157	157	208
Ø B (mm)	45	52	65	80	85	110	115	152	152	152	190
D ₁ ^{H7} /D ₂ ^{H7} (mm)	min.	9	12	15	20	20	25	35	50	50	55
	max.	15	20	32	35	42	50	55	70	70	75
F (mm)	58/66	53/61	73/83	90/102	90/102	100/111	124	164	164	204	225
G (mm)	38/46	31/39	37/47	50/62	51/63	56/67	72	110	110	146	146
H (mm)	24/32	16/24	21/31	24/36	25/37	29/40	40	84	84	84	94
I (DIN 933)	4 x M5	6 x M5	6 x M5	6 x M6	6 x M6	6 x M8	6 x M8	6 x M12	6 x M12	6 x M12	6 x M16

- 1) Keep space for the releasing screws
- 2) Stainless steel version also available

Ordering data	AK/SB 150/98	-	30 ^{H7}	-	35 ^{H7}	-	xxx
Type							
length							
Bore diameter D ₁							
Bore diameter D ₂							
Further details e.g. material							

GERWAH

Backlash-free Metal Bellow Coupling S-Line with pluggable clamping hub

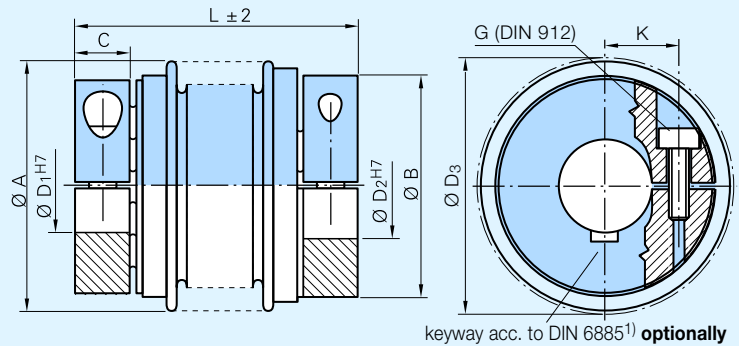

Technical data S-Line

Type	2	4,5	10	18	30	60	80	150
Nominal torque (Nm) T _{KN}	2	4,5	10	18	30	60	80	150
Misalignment (mm) radial ΔK _r	0,2	0,1	0,15	0,2	0,1	0,1	0,2	0,2
(mm) axial ΔK _a	0,4	0,3	0,4	0,5	0,4	0,4	0,4	0,4
(degree) angular ΔK _w	1,2	1,2	1,2	1,5	1	1	1	1
Torsional stiffness (10 ³ Nm/rad) C _{Y dyn}	0,97	4,8	6	6	26	56	97	112
Moment of inertia (10 ⁻³ Kgm ²) J	0,02	0,03	0,04	0,14	0,2	0,8	1,3	3
Tightening torque of the retaining screws ⁵⁾ (Nm) M _A	1	3	3	6	15 / 12	40 / 30	60/55/50	80/70/50
Weight (Kg) m	50	76	96	172	253	456	1650	2020
Max. rotating speed at V=30 m/s (min ⁻¹) n _{max}	22.900	17.600	14.100	12.700	10.200	8.600	6.800	6.800

Dimensions S-Line

Type	2	4,5	10	18	30	60	80	150
L ⁴⁾ (mm) ±2	38	43,5	49	62	65	78	91	91
Ø A (mm)	24	31,8	40	45	56	66	82	82
Ø B (mm)	25	32,5	40	45	47 / 55	57 / 66	80	80
C (mm)	9	9	9	11	15	19,5	21,5	21,5
Ø D ₁ H7 ²⁾ (mm) min. (pluggable side)	3	6	6	10	10	14	28	28
(mm) max.	9	15	19	18	20	23	35	35
Ø D ₂ H7 ²⁾ (mm) min.	3	6	6	10	10	14	28	28
(mm) max.	12	16	19	25	20	23	35	35
Ø D ₃ (mm) Clearance diameter	27	34	41,5	47,5	56	66	91	91
G (DIN 912)	M3	M4	M4	M5	M6	M8	M10	M10
K (mm)	9	11,5	15,5	17,5	20	20 / 24	27	27

Materials: Hubs 2 - 60 made of aluminium, Hubs 80 - 150 made of steel; other materials available on request

- 1) Tolerance of keyway; standard JS9
- 2) Smaller diameters possible for lower torque of transmission
- 3) Stainless steel version also available
- 4) Stretched length
- 5) Tightening torque values increase with increasing outside diameter of coupling hubs

Ordering data

S-Line 150 - 30^{H7} - 35^{H7} - xxx

Type

Bore diameter D₁

Bore diameter D₂

Further details e.g. material, keyway

GERWAH®

Backlash-free Metal Bellow Coupling Series CK for flange mounting

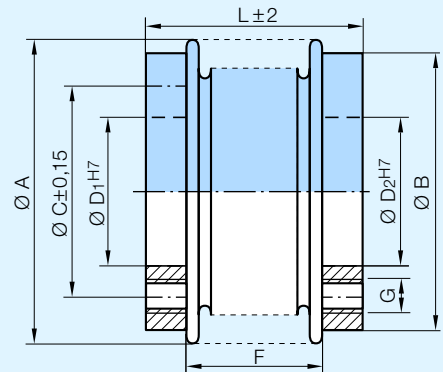

Technical data series CK

Type	18	30	60	80	150	200	300	500	800	1400	3000	5000
Nominal torque (Nm) T_{KN}	18	30	60	80	150	200	300	500	800	1400	3000	5000
Torsional stiffness (10^3 Nm/rad) C_{Tdyn}	8/6	35/25	75/50	130/75	150/100	170/120	500/280	310	760	1300	2800	4800
radial spring stiffness (N/mm) C_r	200/85	720/220	1100/330	1200/400	2000/600	2500/450	6300/1500	1000	510	710	2950	4920
axial spring stiffness (N/mm) C_a	50/40	50/30	90/55	80/55	150/85	150/85	280/150	85	190	280	310	510
Moment of inertia (10^{-3} Kg m^2) J	0,05	0,09	0,3	0,67	0,84	1,50	3,75	5	11	11	11	60
Weight (approx. kg) m	0,2/0,25	0,2/0,3	0,2/0,3	0,6/0,7	0,65/0,75	1,0/1,15	1,6/1,8	1,8	2,9	2,9	2,9	16
Max. approved misalignment (mm)	0,2	0,1/0,2	0,1/0,2	0,2/0,2	0,2/0,2	0,2/0,2	0,2/0,2	0,2	0,2	0,2	0,2	0,2
axial ΔK_a (mm)	0,5	0,4/0,5	0,4/0,5	0,4/0,5	0,4/0,5	0,4/0,5	0,4/0,5	1	1	1	1	1
angular ΔK_w (degree)	1,5	1,0/1,5	1,0/1,5	1,0/1,5	1,0/1,5	1,0/1,5	1,0/1,5	1,5	1,5	1,5	1,5	1,5
Max. rotating speed at $V=30$ m/s (min $^{-1}$) n_{max}	13900	11000	9000	7100	7100	6600	5200	4600	3700	3700	3700	3000

Dimensions series CK

Type	18	30	60	80	150	200	300	500	800	1400	3000	5000
L (mm) ± 2	36/44	30/37	41/51	51/61	52/62	51/63	47/67	73	130	130	130	145
$\varnothing A$ (mm) max.	45	56	66	82	82	90	110	122	157	157	157	208
$\varnothing B$ (mm)	41	52	63	80	80	86	110	122	152	152	152	208
$\varnothing C$ (mm)	31	37	46	62	62	62	80	94	110	110	110	130
D_1^{H7}/D_2^{H7} 1)	22	28	38	50	50	50	65	70	85	85	85	100
F (mm)	24/32	16/24	21/31	24/35	24/36	24/37	28/41	41	87	87	84	94
G	6xM5	6xM5	6xM6	6xM6	6xM6	6xM6	6xM8	6xM8	6xM16	6xM16	6xM16	6xM16
Thread depth (mm)	6	7	10	13	13	13	13	16	18	18	22	25

1) Other bore diameters available on request

2) Stainless steel version also available

Ordering data

CK 150/52	-	50 ^{H7}	-	50 ^{H7}	-	xxx
Type	length					
Bore diameter D_1						
Bore diameter D_2						
Further details e.g. material, keyway						

GERWAH

Design Sample Calculation

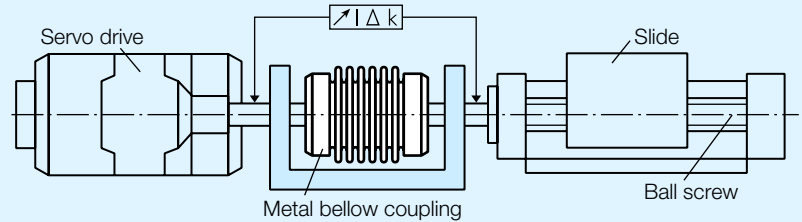

Design / Product information

Backlash-free, torsionally stiff metal bellow couplings are ready to install when delivered. The metal bellows are made of stainless steel, all other parts are made of aluminium or steel and partly have environmental friendly protective coating.

As a standard, the boreholes are equipped with a fitting in accordance with ISO-H7. For the shafts, we recommend a transition, e.g. H7/g6. When selecting other shaft fitting, the fitting should not exceed a maximum of 0,01 – 0,05 mm.

The power transmission between the coupling hub and the shaft occurs through compression and friction between the contact surfaces. Special attention must be paid to the tightening torque of the retaining screws as well as the perfect condition of the contact surfaces. The contact surfaces must be free of oil and grease when having a depth of roughness of R_{tmax} . 16 μ for the shaft. Versions with keyway are available.

The torques indicated can only be safely transferred if these points are complied with. Otherwise compromises must be accepted.

Dimensioning in accordance with the torque

Metal bellow couplings are generally designed according to the nominal torque stated in the list of technical data below as TKN.

The nominal torque must always be higher than the regular transferred torque. This generally applies to the use of servo motors, whose acceleration moment in positive and negative directions is much higher than the nominal moment.

For the use of metal bellow couplings which are put in controlled, high dynamic drives, the following dimensioning values have proven to be reliable in practice:

Calculation for the application of a metal bellow coupling in a machine tool drive

Drive related data for servo motor I FT 5104:

Maximum torque TAS = 160 Nm

Moment of inertia $J_{Mot} = 18,3 \times 10^{-3} \text{ kgm}^2$

Output data for machine tool:

Moment of inertia of ball screw and slide

$J_{Mach} = 17 \times 10^{-3} \text{ kgm}^2$

The low moment of inertia of the metal bellow coupling is disregarded. K = Load factor, impulse factor selected for this drive K = 2 ;

Design according to torque:

$$T_{KN} \geq K \times T_{AS} \times \frac{J_{Mach}}{J_{Mot} + J_{Mach}} = 2 \times 160 \text{ Nm} \times \frac{17 \times 10^{-3} \text{ Kgm}^2}{(18,3 + 17) \times 10^{-3} \text{ Kgm}^2} = 154 \text{ Nm}$$

Coupling selection: AKD 200, $T_{KN} = 200 \text{ Nm}$, $C_{Tdyn} = 116 \times 10^3 \text{ Nm/rad}$

The metal bellow coupling is sufficient dimensioned, since $200 \text{ Nm} \geq 154 \text{ Nm}$

Design according the resonance frequency:

$$f_{res} = \frac{1}{2\pi} \sqrt{C_{Tdyn} \times \frac{J_{Mot} + J_{Mach}}{J_{Mot} \times J_{Mach}}} = \frac{1}{2\pi} \times \sqrt{116000 \text{ Nm/rad} \times \frac{0,0183 + 0,017 \text{ Kgm}^2}{0,0183 \times 0,017 \text{ Kgm}^2}} = 578 \text{ Hz}$$

The arithmetic calculation is clearly much higher than the expected resonance frequency.

K = 1,5 for evenly shaped movements

K = 2 for unevenly shaped movements

K = 2,5 for jerky movements

$$T_{KN} \geq K \times T_{AS} \times \frac{J_{Mach}}{J_{Mot} + J_{Mach}} = [\text{Nm}]$$

For servo drives within tool making machines, the values for K = 1,5 – 2 should be used.

Design with consideration for dynamic torsional stiffness

Although metal bellow couplings are backlash-free and torsion-rigid, it should not be overlooked that they link two rotating masses. In disadvantageous cases the couplings can effect like torsion springs with high stiffness. The hunting of the drives and the harmonic oscillation in the

armature current of the motor must therefore never be within the range of the mechanical resonance frequency.

$$f_{res} = \frac{1}{2\pi} \sqrt{C_{Tdyn} \times \frac{J_{Mot} + J_{Mach}}{J_{Mot} \times J_{Mach}}} = [\text{Hz}]$$

In practice the resonance frequency "f_{res}" must be twice as large as the excitation frequency of the drive. The dynamic torsional stiffness C_{Tdyn} was selected so that it would not be within the range of clearance diameter from most applications. Various levels of torsional stiffness are available as standard versions.

We would be pleased to design your metal bellow couplings for you. Feel free to use our experience and know-how for your success.

Speak to us!

GERWAH®

Type Series Versions Installation Examples

Variable series

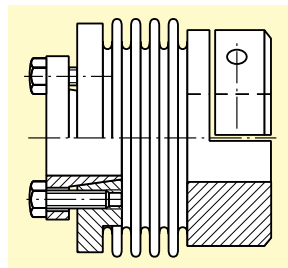

Series AK/AKD
Model with clamping hub and inner conical hub

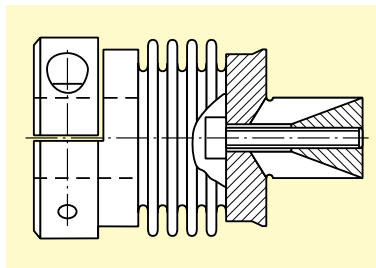

Series AKN/S
Model with clamping hub and expanding clamps

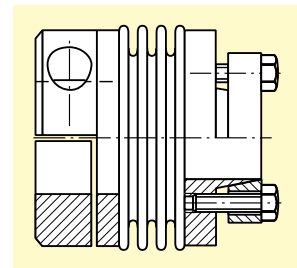

Series AKD/AK/SB
Model with clamping hub and outer conical hub

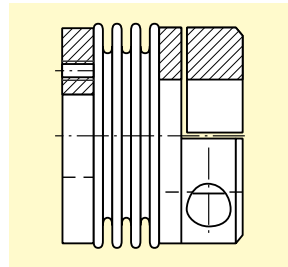

Series AKD/CK
Model with clamping hub and flange

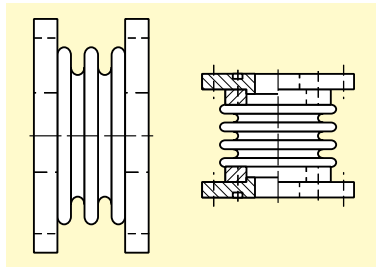

Series CK/XX
Model with special flange

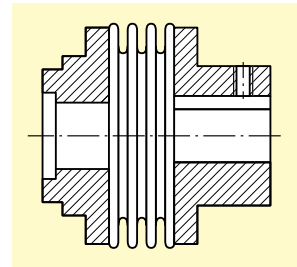

Series AKN/XX
Version with special hub on both sides

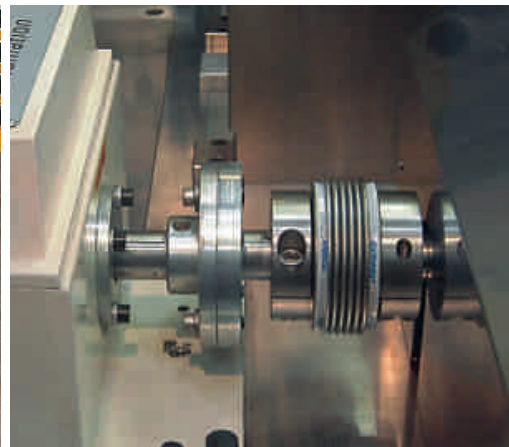
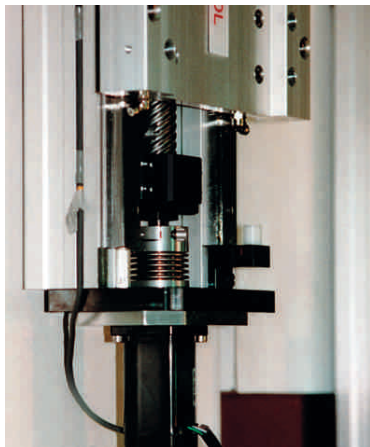

Sample applications

GERWAH®

Metal Bellow Couplings Mounting Instruction

Types of misalignment (figure 1)

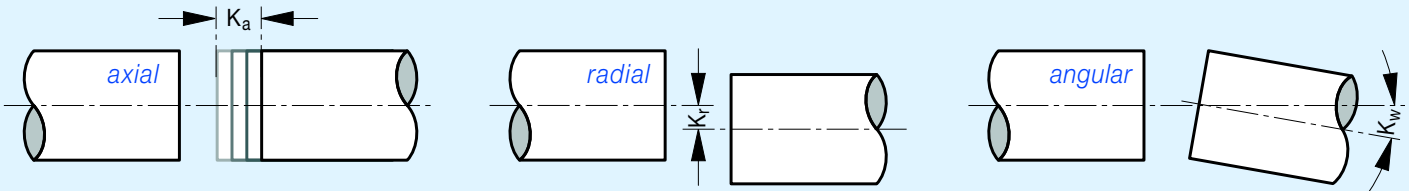

Assembly

Clean shaft ends and bores in hubs, degrease and check the tolerances.

Insert both shaft trunks into the hubs of the metal bellow coupling, and firmly tighten the screws, after examining the axial installation dimensions.

The tightening torque of the screws and the maximum approved misalignment should not be exceeded (refer to the list of technical data).

Removal

After loosening the backlash-free shaft hub connections, the drive can be pulled apart and the metal bellow coupling can be removed.

Conical bushings for series AK are forced off with a hexagonal socket screw.

Alignment

If several types of misalignment appear simultaneously, then each of the individual values should not exceed 100%. Figure 2 shows how to regulate.

The more precise the alignment, the more reserves are available to handle additional misalignments for operation. This will have an advantageous effect on the service life, balance quality, and the accuracy of transmission.

If several types of misalignment occur at once, then the value must be lower than each of the maximum values.

Please ask for our detailed assembly instructions.

Design example

Application: A bellow coupling CK80/61 has to be installed. The following misalignment values result from the installation situation:

$$\begin{aligned}\Delta K_r &= 0,1 \text{ mm} \\ \Delta K_a &= 0,1 \text{ mm} \\ \Delta K_w &= 0,2^\circ\end{aligned}$$

Are the misalignment values for the CK80/61 acceptable?

Selection: (cp. details page 11): the tolerable misalignment values are:

$$\begin{aligned}\Delta K_{rn} &= 0,2 \text{ mm} \\ \Delta K_{an} &= 0,5 \text{ mm} \\ \Delta K_{wn} &= 1,5^\circ\end{aligned}$$

The reached radial misalignment $\Delta K_r = 0,1 \text{ mm}$ corresponds to 50% of the max. tolerable value. The value $\Delta K_a = 0,1 \text{ mm}$ corresponds to 20% of the max. tolerable axial misalignment. The angular misalignment with $\Delta K_w = 0,2^\circ$ corresponds to 13% of the overall view.

Interpretation by means of the diagram: Enter the calculated values in the diagram on the right side (dashed line). The combination of the different misalignment values is in the tolerable area.

Interpretation by means of the empirical formula:
 $50\% + 20\% + 13\% < 100\%$.
 The coupling can be installed.

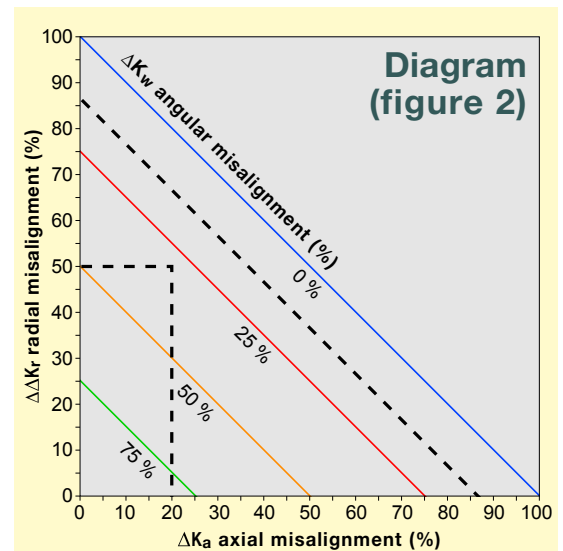

Empirical formula:

$$\frac{\Delta K_r}{\Delta K_{rn}} \times 100\% + \frac{\Delta K_a}{\Delta K_{an}} \times 100\% + \frac{\Delta K_w}{\Delta K_{wn}} \times 100\% < 100\%$$

Checklist for Your Couplings Inquiry

For your convenience just copy, fill out and fax back to us!

company	name
street	dpt.
ZIP/town	eMail
phone	fax

Please ask for personalized technical assistance!

1. Application: how is the coupling supposed to be used? (machine, machine group or system)

2. Type of connection

clamp ring hub shrink disc hub locking assembly hub hub with set screw
 flange connection outer cone Fanuc spec. customer drawing

3. Dimensions

Length mm bore size D1 mm keyway yes no
Diameter mm bore size D2 mm keyway yes no

4. Misalignment of shafts

axial mm radial mm angular °

5. Drive

5.1 Drive output $P_{AN} =$ kW
5.2 Drive speed $n =$ 1/min
5.3 Nominal torque of drive $Mt_{nenn} =$ Nm
5.4 Peak torque of drive $Mt_{max} =$ Nm

6. Mass moment of inertia

6.1 Drive side $J_A =$ Nm
6.2 Driven side $J_L =$ Nm

7. Special influences

7.1 Ambient temperature surrounding the coupling? $T =$ °C
7.2 Are there any shock loads? light medium heavy
7.3 Special materials (e.g. stainless steel)
7.4 Special circumstances

8. Planned quantities

production prototype repair yearly quantity

9. Target price

€/piece

Sales Representative

GERWAH®

Log on to

www.gerwah.com

for:

- Complete catalog info
- 3D-CAD product drawings
- Calculation software
- Product and corporate news
- And much more

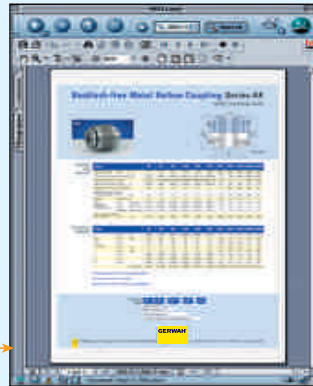

Your GERWAH® Partner

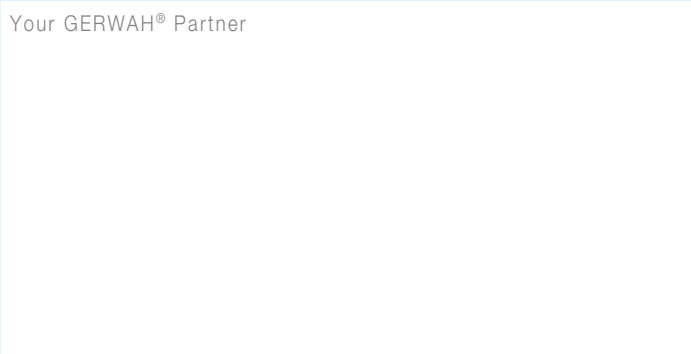

GERWAH GmbH

Phone (49)06022/2204-0

Fax (49)06022/2204-11

eMail info@gerwah.com

www.gerwah.com

Luetzeltaler Strasse 5a

D-63868 Grosswallstadt

Germany

DIN EN ISO 9001:2000

PETER® is a registered trade mark of GERWAH GmbH