

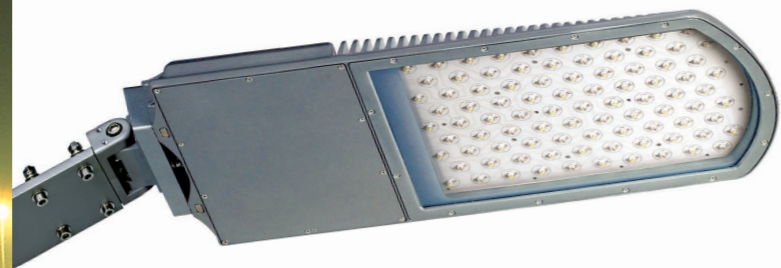

Technical Specifications



120 LED High Power Street Light Series

150 LED High Power Street light Series



Item No.	NEOJ2022-00	NEOJ2022-10	NEOJ2022-21
Type	150 LED High Power Street Light Head Unit	150 LED High Power Street Light (Single Head)	150 LED High Power Street Light (Double Head)
Light source	150x1W high power LED	150x1W high power LED	150x1W high power LEDx2
Color temperature	2000K±200K	2000K±200K	2000K±200K; 6500K±500K
Luminous flux	5722Lm	5722Lm	5722Lm
Average Illumination	11Lux/9m	11Lux/9m	11Lux/9m
Area of Illumination	±13.5m	±13.5m	±13.5m
Input voltage	100-240V AC,50/60HZ	100-240V AC, 50/60Hz	100-240V AC,50/60Hz
LED operating current	24V DC	24V DC	24V DC
Total LED Power	189W	189W	189WX2
Installation tube diameter	Ø60mm (Max.)	NA	NA

The Auto Switching Technology(AST) sensor is located on the adjoining bracket between the pole coupler and the LED fixture. AST works by Auto Switching "turning on" the High Power LED Street Light when the luminance of sunlight is lower than 13LUX and off again when a LUX factor greater than 13 is sensed.

AST=Automatic Switching Technology



Item No.	NEOJ2021-00	NEOJ2021-10	NEOJ2021-20
Type	120 LED High Power Street Light Head Unit	120 LED High Power Street Light (Single Head)	120 LED High Power Street Light (Double Head)
Light source	120x1W high power LED	120x1W high power LED	120x1W high power LEDx2
Color temperature	2000K±200K; 6500K±500K	2000K±200K; 6500K±500K	2000K±200K; 6500K±500K
Luminous flux	5308Lm	5308Lm	5308Lmx2
Average Illumination	14Lux/8m	14Lux/8m	14Lux/8m
Area of Illumination	±12m	±12m	±12m
Input voltage	100-240V AC,50/60Hz	100-240V AC, 50/60Hz	100-240V AC, 50/60Hz
LED operating current	24V DC	24V DC	24V DC
Total LED Power	143W	143W	143Wx2
Installation tube diameter	Ø60mm (Max.)	NA	NA

The Auto Switching Technology(AST) sensor is located on the adjoining bracket between the pole coupler and the LED fixture. AST works by Auto Switching "turning on" the High Power LED Street Light when the luminance of sunlight is lower than 13LUX and off again when a LUX factor greater than 13 is sensed.

AST=Automatic Switching Technology

CE, UL, IP65

Candle Power Distribution

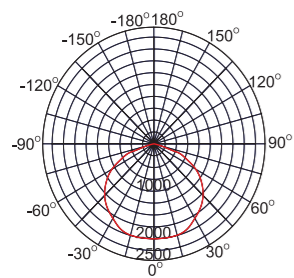

Max. Light Intensity: 2013.15 cd

ISO-Illuminance Curve

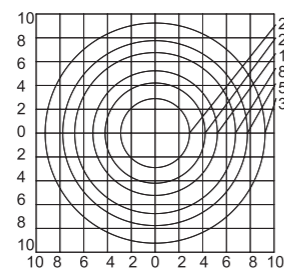

Hight: 8m
Max. Illumination: 32.14LUX

Dimensions of Framework

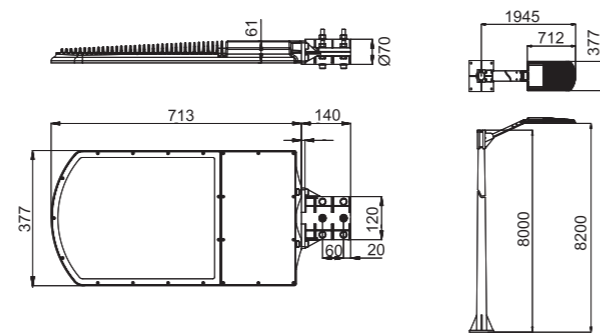

NEOJ2021-00

NEOJ2021-10

Candle Power Distribution

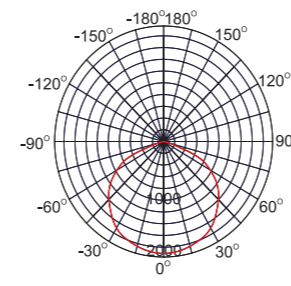

Max. Light Intensity: 1923.67 cd

ISO-Illuminance Curve

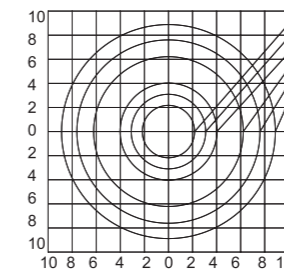

Hight: 6m
Max. Illumination: 52.28LUX

Dimensions of Framework

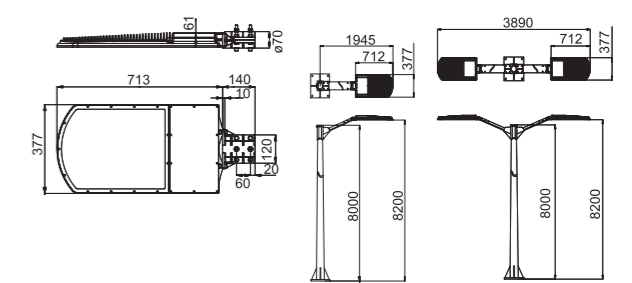

NEOJ2022-00

NEOJ2022-10

NEOJ2022-21