

OWNER'S MANUAL

10" CABINET SAW

Models CB31230, CB33230,
CB51230, CB53230, CB53480



Copyright 2004, SawStop, LLC
Patents Pending
All Rights Reserved.

1st printing, December 2004

Updates of this manual may be
available at www.sawstop.com

The saw shown on the front cover includes
the optional 36" fence and extension table. Your saw
may look different.

To Our Customers

Thank you for purchasing a SawStop cabinet saw! It is the safest, most technically advanced table saw ever made. As you will soon discover, the features of the SawStop cabinet saw establish new standards in the table saw industry.

Your saw includes our revolutionary, award-winning technology that can tell the difference between cutting wood and cutting a person. If you ever accidentally contact the moving blade, the technology will detect that contact and stop the blade in milliseconds to minimize any injury.

This manual tells you more about your saw and how to operate and maintain it. Please read the manual carefully. The manual also includes our warranty and important safety information.

Again, thanks for purchasing a SawStop saw. We are confident you will be pleased with its performance. If you ever have any questions or comments, feel free to contact us at the address below.

SawStop, LLC
22409 S.W. Newland Road
Wilsonville, Oregon 97070 USA
Phone - (503) 638-6201
Fax - (503) 638-8601
Email - info@sawstop.com
www.SawStop.com

Table of Contents

Warranty	5
No Warranty of Safety	5
Safety	6
WARNINGS	6
Warning Labels	8
The SawStop Safety System	10
Unpacking Your Saw	13
Get to Know Your Saw	14
Cabinet Saw Specifications	16
Setting Up Your Saw	17
1. Saw Placement:	17
2. Extension Wing Assembly:	17
3. Table and Extension Wing Cleaning:	17
4. Rip Fence Installation:	17
5. Tilt Hand Wheel Handle Installation:	18
6. Blade or Dado Installation:	18
7. Brake Position Adjustment:	
8. Blade Guard / Riving Knife Installation:	21
9. Table Insert Installation:	23
10. Connection of Dust Collection:	24
11. Electrical Power Connection:	25
11. Disconnect Switch:	26
Using Your Saw	27
1. Adjusting the Blade Height:	27
2. Adjusting the Blade Tilt Angle:	27
3. Turning on Main Power and Starting the Motor:	28
4. System Status Codes:	30

Table of Contents

5. Using the Saw in Bypass Mode:	33
6. Using the Blade Guard:	34
7. Using the Riving Knife:	35
8. Using the Miter Gauge:	35
9. Cross-Cutting:	37
10. Rip Cutting:	38
11. Changing the Brake Cartridge:	41
What to do if the SawStop Safety System Activates	45
Making Adjustments to Your Saw	46
1. Aligning the Blade Elevation Assembly:	46
2. Aligning the Table:	50
3. Aligning the Blade to the Tilt Axis:	53
4. Adjusting the Elevation Limit Stops:	57
5. Adjusting the Tilt Limit Stops and Tilt Angle Indicator:	59
6. Adjusting the Table Insert:	61
7. Aligning the Riving Knife and Spreader to the Blade:	62
8. Adjusting the Tilt Gearing:	65
9. Adjusting the Miter Gauge:	66
Troubleshooting	67
Maintenance	70
1. SawStop Safety System:	70
2. Cabinet:	70
3. Elevation and Tilt Mechanisms:	70
4. Table and Extension Wings:	70
5. Belts:	70
Cabinet Saw Dimensions	71
Push Stick Construction	73
Featherboard Construction	74

Table of Contents

Electrical Schematic — 230V, Single-Phase (3 and 5 HP)	75
Electrical Schematic — 230V, Three-Phase (3 and 5 HP)	76
Electrical Schematic — 460V, Three-Phase (5 HP)	77
Cabinet and Table Assembly Exploded View	78
Cabinet and Table Assembly Parts List	79
Internal Assembly Exploded View	81
Internal Assembly Parts List	82
Arbor Assembly Exploded View	85
Arbor Assembly Parts List	86
Miter Gauge and Blade Guard Assemblies Exploded View	88
Miter Gauge and Blade Guard Assemblies Parts List	89
Accessories	90
Index	91

Warranty

SawStop warrants to the original retail purchaser of the table saw accompanying this manual that the saw will be free from defects in material and workmanship for **two years** from the date of purchase, and that the electric motor supplied with the saw will be free from defects in material and workmanship for **five years** from the date of purchase. This warranty does not apply to defects arising from misuse, abuse, negligence, accidents, normal wear-and-tear, unauthorized repair or alteration, or lack of maintenance. This warranty is void if the saw or any portion of the saw or accessory is modified without the prior written permission of SawStop, LLC.

To take advantage of this warranty you must return the product or part along with proof of purchase to the service center specified by SawStop, postage prepaid, and within the applicable warranty period. If SawStop determines the product or part is defective in workmanship or material, and not due to misuse, abuse, negligence, accidents, normal wear-and-tear, unauthorized repair or alteration, or lack of maintenance, SawStop shall, at its option, repair or replace the product or part at its expense.

SawStop disclaims any and all other express or implied warranties, including merchantability and fitness for a particular purpose. SawStop shall not be liable for death, injuries to persons or property, or incidental, consequential, contingent or special damages arising from the use of the saw.

Please contact SawStop to take advantage of this warranty.

This warranty gives you specific legal rights. You may have other rights which vary from state to state.

No Warranty of Safety

It is important to understand that SawStop table saws **do not prevent injuries**. They work to **minimize the severity of injuries**. In fact, an injury must occur before the SawStop technology reacts. The severity of the injury will depend on the speed at which a person contacts the spinning blade. You may incur a serious injury on a SawStop saw. If you decide to use the saw in Bypass mode, the safety system will be disabled and it will not activate in the event you contact the spinning blade.

Safety

A table saw is a dangerous tool and there are hazards inherent with using this saw. Some of these hazards are discussed below. Use common sense when operating the saw and use the saw only as instructed. ***You are responsible for your own safety!***

WARNINGS

1. Read and understand the instruction manual and all safety warnings before operating this saw. Failure to follow instructions or heed warnings may result in electric shock, fire, serious personal injury or property damage. Save these instructions and refer to them whenever necessary.
2. Some dust created by sawing, power sanding, grinding, drilling, and other construction activities contains chemicals known to cause cancer, birth defects or other reproductive toxicity or harm. Some examples of these chemicals are lead from lead-based paints, crystalline silica from bricks, cement, and other masonry products, and arsenic and chromium from chemically treated lumber.

In addition, wood dust has been listed as a known human carcinogen by the U.S. government.

The risk from exposure to these chemicals and to dust varies depending on how often you do this type of work. To reduce your exposure, work in a well ventilated area and work with approved safety equipment including dust masks or respirators designed to filter out such dust and chemicals.

3. This saw must be connected to a grounded metal permanent wiring system or to a system having an equipment-grounding conductor. In the event of a malfunction or breakdown, grounding provides a path of least resistance for electric current to reduce the risk of electric shock.

Improper connection of the equipment-grounding conductor can result in a risk of electric shock and/or malfunction.

Check with a qualified electrician or service personnel if the grounding instructions are not completely understood or if in doubt as to whether the tool is properly grounded.

4. Use only identical replacement parts when servicing the saw.
5. Keep guards in place and in working order.
6. Remove adjusting keys and wrenches from the saw before turning it on.
7. Keep the top of the saw clean and free from clutter. Cluttered areas invite accidents.
8. Do not use the saw in dangerous environments. For example, do not use the saw in damp or wet locations or expose it to rain; and keep the work area well lighted.
9. Keep children away from the saw. Make the workshop kid-proof with padlocks, master switches, or by removing starter keys.

WARNINGS

10. Do not try to force the saw to do something it was not designed to do. For example, do not try to cut wood faster than the motor can handle, and use the right blade for the job.
11. Wear proper apparel when using the saw. Do not wear loose clothing, gloves, neckties, rings, bracelets, or other jewelry which may get caught in moving parts. Non-slip footwear is recommended. Wear a protective hair covering to contain long hair.
12. Always wear safety glasses when using the saw. Also use a face or dust mask if the cutting operation is dusty. Everyday eyeglasses are not safety glasses.
13. Do not overreach or stretch to get something when using the saw. Keep proper footing and balance at all times.
14. Maintain the saw as specified in this manual.
15. Turn the power disconnect switch to OFF before servicing the saw and when changing components or accessories such as blades, brake cartridges, and the like.
16. Use only recommended accessories with the saw. Consult this manual for recommended accessories. The use of improper accessories may cause risk of injury to persons.
17. Never stand on the saw. Serious injury could occur if the saw is tipped or if the cutting tool is unintentionally contacted.
18. Check to make sure the saw is in proper working order before using the saw. For example, check the alignment of moving parts, look to see whether moving parts are binding or rubbing, check to see whether parts are broken, make sure accessories are properly mounted in the saw, and check any other conditions that may affect the operation of the saw. A guard or other part that is damaged should be properly repaired or replaced.
19. Feed work into the blade or cutter against the direction of rotation of the blade or cutter only. Feeding the work in the direction of rotation may cause the work to be thrown by the blade and could result in serious personal injury
20. Never leave the saw running unattended. Wait until the blade comes to a complete stop, and then turn both the Main Power switch and the Disconnect switch to OFF when you are finished using the saw.
21. This saw is packaged without a rip fence. You must install a rip fence before using this saw. Attempting to use the saw without a rip fence could result in a serious personal injury.
22. Always maintain firm control over the material being cut. Never cut any material freehand.

Warning Labels

Warning labels are mounted on the front, rear and side of the saw, on the table insert, and on the blade guard for your reference. Some of the warnings on those labels may be additional to the warnings listed above. Be sure to read the warning labels before using the saw. Copies of the English text of the warning labels are reproduced below:

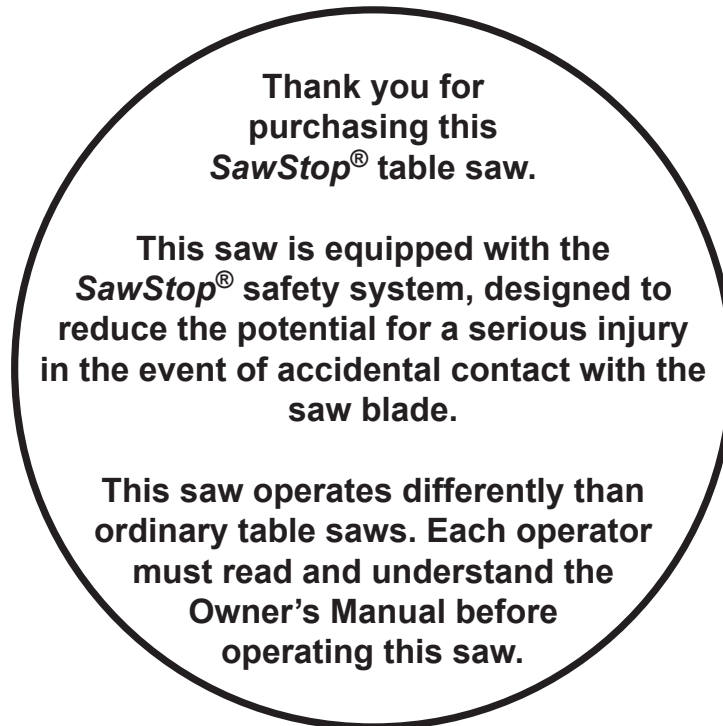

 **WARNING**

For your own safety, read the instruction manual before operating this saw.

1. Wear eye protection.
2. Use the blade guard and spreader for every operation for which it can be used, including all through sawing.
3. Keep hands out of the line of the saw blade.
4. Use a push-stick when required.
5. Know how to reduce the risk of kickback.
6. Do not perform any operation freehand.
7. Never reach around or over the saw blade.
8. Unplug the saw before changing the blade or servicing.
9. Never try to test fire the brake system.
10. Never adjust the position of the brake cartridge while the blade is spinning.
11. Do not try to disable the brake system.
12. Unplug the saw before changing the blade, changing the brake cartridge or servicing.
13. Do not connect the motor directly to a power supply.
14. Use the bypass switch only when necessary.

! WARNING



Moving belts and parts can pinch, cut or crush.

Do not operate with door open.

Lockout before servicing.

(On saws with 230V, single phase motors.)

! WARNING

Connect Only 208-240 Volts, Single Phase Power.

This machine must be connected to an electrical ground in accordance with the National Electrical Code. Failure to connect to an adequate ground may cause the safety system to malfunction and could result in a serious injury.

! WARNING

To avoid loss of SawStop protection during coast down, do not turn off Main Power until blade has stopped spinning.

! WARNING

1. Use the blade guard and spreader for every operation for which it can be used.
2. Use the riving knife for non-through sawing.
3. Keep hands away from the saw blade. Use a push-stick when required.

(On saws with 230V, three phase motors.)

! WARNING

Connect Only 208-240 Volts, Three Phase Power.

This machine must be connected to an electrical ground in accordance with the National Electrical Code. Failure to connect to an adequate ground may cause the safety system to malfunction and could result in a serious injury.

(On saws with 480V, three phase motors.)

! WARNING

Connect Only 460-480 Volts, Three Phase Power.

This machine must be connected to an electrical ground in accordance with the National Electrical Code. Failure to connect to an adequate ground may cause the safety system to malfunction and could result in a serious injury.

The SawStop Safety System

This table saw is equipped with the SawStop® safety system. This revolutionary technology was developed to reduce the potential for a serious injury in the event of accidental contact with the saw blade. SawStop® table saws are the first saws ever built to be smart enough to know the difference between you and the wood you are cutting.

The SawStop® safety system includes two components, an electronic detection unit and a fast-acting brake. The electronic detection unit detects when a person contacts the blade. A small electrical signal is induced onto the blade by electrodes placed around the arbor. Although this low voltage, high frequency signal is too small to feel, it can be measured by the detection system. When human skin comes into contact with the blade (or arbor), a portion of the signal is absorbed by the body due to the inherent electrical capacitance of the human body. As a result, the signal on the blade gets smaller and the detection unit recognizes this as contact.

Wood and other non-conductive materials such as plastic, foam, cardboard, Corian®, melamine, etc., do not cause a drop in the signal because those materials do not absorb the signal on the blade. Conductive materials such as aluminum and other metals, carbon fiber materials, etc., will ground the blade to the cast-iron table top, thus causing the signal on the blade to drop to zero and activating the brake. If you need to cut these conductive materials, the safety system can be placed in “Bypass” mode to temporarily disable the brake. (The Bypass mode is discussed on page 33.)

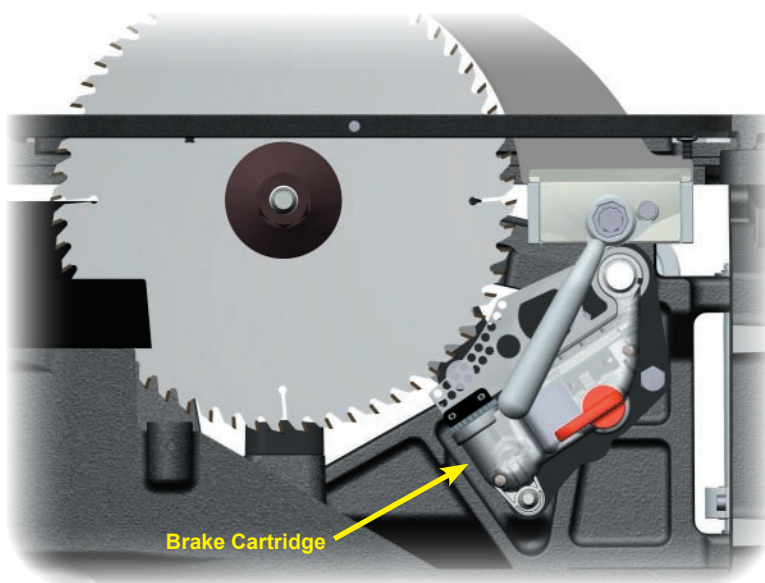

Figure 1

The fast-acting brake includes a small fuse that holds a strong spring in compression. If the electronic detection unit detects contact while the blade is spinning (including during coast down), the fuse is burned by a surge of electricity. The spring then pushes an aluminum brake into the teeth of the spinning blade. The teeth cut into the brake, stopping the blade. The total time between the detection of contact and stopping the blade is just a few milliseconds. If the brake is activated while the blade is at or near full speed, the blade will also quickly retract below the table. The system will not activate the brake when the blade is stopped—even if you spin the blade by hand. This allows you to touch or change the blade when the motor is off just as with ordinary table saws. However, for safety, always switch the Main Power and Disconnect switch to OFF when changing the blade.

The SawStop® safety system is active whenever the Main Power is on. The safety system continuously performs many different self-checks to ensure that the components of the system are operating properly. If any errors are detected, the safety system will disable the motor and display an error code to identify the problem (see page 30 for a description of the error codes and the corrective action). If the error is detected while the motor is spinning, the motor will be shut off. The safety system will not allow the motor to be started, even in “Bypass” mode, as long as an error is present.

The electronic detection unit and fast-acting brake are contained in the “brake cartridge,” which is positioned under the table and just behind the blade (see Fig. 1). The brake cartridge must be correctly installed before the motor can be started (see page 41 for instructions on removing/installing the brake cartridge). In the event that the brake is activated, a new brake cartridge must be installed before the saw can be used again.

The SawStop Safety System

The SawStop® safety system does not interfere with your use of the table saw in any way. You can still make all the cuts that you can with ordinary saws including 0° to 45° bevels, non-through cuts, and dado cuts (with the optional dado brake cartridge—sold separately). Furthermore, no special blades or other accessories are required. Any standard 10" saw blade or 8" dado set is compatible with your SawStop® saw.

Although your SawStop® saw operates similar to ordinary table saws, there are a few important points to keep in mind as you use the saw.

1. **Do not** rely on the SawStop® safety system to protect against unsafe operation. Although the system is designed to react and stop the blade very quickly in the event of accidental contact, it cannot react until contact is detected. This means that you will receive at least a minor injury even with the SawStop® safety system. Therefore, always use safe operating practices, and use the blade guard, push stick and other safety devices whenever possible. The SawStop® safety system, like the airbag in a car, should be considered as a last measure to minimize injury when all other safety practices and devices have failed to prevent an accident.

2. **Do not** operate the saw in Bypass mode unless you are cutting electrically conductive material. When Bypass mode is engaged, the SawStop® safety system will not activate the brake if contact is detected and a serious injury could result if you contact the blade.

3. **Do not** use non-conductive blades, including abrasive blades, blades with plastic hubs, or blades that have non-conductive teeth. The safety system cannot induce the electrical signal onto a non-conductive blade, and blades with non-conductive teeth may prevent the system from detecting contact. Only standard steel blades with either steel or carbide teeth should be used.

4. **Do not** use saw blades or dado sets that have a lacquer or other coating on the teeth. These coatings are non-conductive and therefore can reduce the speed at which the system detects contact. In other words, a coated tooth must cut slightly deeper into the skin for contact to be detected, resulting in a somewhat more serious injury. Once coated blades have been used several times, the coating typically is worn away and the blade will trigger the safety system just as quickly as uncoated blades.

5. In the event of contact, the blade will be stopped in about 3–5 milliseconds (coarse toothed blades stop more quickly than fine-toothed blades such as plywood blades). Therefore, the seriousness of the injury incurred will depend on the speed at which a person's hand or other body part is moving in toward the blade. For example, if a person's hand is moving toward the blade at 1 ft./sec., then the depth of the cut will be approximately (1 ft./sec. * 0.005 sec. = 0.005 ft. or 1/16th inch). At faster speeds, the cut will be proportionally deeper. **Therefore, it is possible to be very seriously injured even with the SawStop® safety system.**

6. **Never** use a blade with damaged or missing teeth as this can result in a more serious injury or a false activation of the brake. Blades with variable spacing between teeth are compatible with the SawStop® safety system, however you must ensure the brake is positioned correctly by rotating the blade at least one full revolution to be certain that none of the teeth will touch the brake (see page 19 for more information on setting the brake position.)

7. **Never** attempt to use a blade other than a single 10 inch blade with the standard SawStop® brake cartridge. **Never** attempt to use a dado set or blade other than an 8 inch dado set with the SawStop® dado cartridge. The use of smaller diameter blades with a brake cartridge designed for larger blades could result in a serious injury because the brake cannot be positioned correctly to stop the smaller blades.

8. **Never** install the blade backwards. The brake might not stop a blade that is installed backwards, therefore you may receive a serious injury.

The SawStop Safety System

9. **Never** install two or more 10 inch blades together. The safety system is not designed to stop multiple stacked 10 inch blades and a serious injury may result.

10. **Never** stack dado blades thicker than 13/16". The 8 inch dado brake cartridge is not designed to stop dado stacks thicker than 13/16" and a serious injury may result.

11. The motor cannot be started without a blade installed. Since the safety system disables the motor if the blade is spaced too far from the brake, a missing blade will be detected as a blade-to-brake spacing error and the motor will be disabled.

12. **Do not** use table inserts, guards, fences or other devices which have metal parts that may come into contact with the blade. Any metal part that contacts the blade may cause the brake to activate. All *SawStop*[®] accessories are specifically designed to prevent metal contact with the blade.

13. **Do not** turn off the Main Power switch before the blade has stopped spinning. If the Main Power is shut off while the blade is moving, the safety system will not be active during coast down and therefore the brake will not activate in the event of accidental contact. You may receive a serious injury if you contact the blade during coast down if the Main Power switch has been turned off.

14. **Do not** replace the arbor belt with a non-*SawStop*[®] belt. The *SawStop*[®] arbor belt is designed to dissipate static electricity that may build up on the spinning blade which could cause a false activation of the brake.

15. **Never** reach under the blade while it is spinning. In the event the brake is activated, the retraction of the blade may cause a very serious injury if you contact the bottom of the blade.

16. **Never** touch the arbor, arbor pulley, arbor nut or arbor washer when the blade is spinning because you may receive a serious injury. These parts are all electrically coupled to the blade and the brake will activate if contact with these parts is detected.

17. **Never** attempt to disable the *SawStop*[®] safety system or modify the electrical wiring of the saw in any way. Any change or modification or disablement of the safety system or other wiring could result in a serious injury and will void all warranties.

18. **Never** attempt to repair, adjust, modify or otherwise service a brake cartridge. There are no user-servicable parts inside the brake cartridge. The brake cartridge is permanently sealed against dust and other contaminants—destruction, removal, or alteration of this seal voids all warranties.

19. Always provide a high quality power supply for your saw. *SawStop* saws include a small internal computer which could potentially be affected by current surges or other electrical noise on a power line. If the power supply is very noisy, it is possible that the brake system will activate incorrectly. If necessary, you can add a line filter or conditioner to the input power supply to reduce the effect of noise.

Unpacking Your Saw

Use care when unpacking your saw to prevent damage to any of the saw components or accessories. Remove all packing materials and accessories before removing the saw from the shipping pallet. If the saw or the accessories have been damaged during shipping, report the damage to your shipper before proceeding with unpacking. Read and understand this manual fully before assembling and operating your saw.

The package for your saw includes the following items:

1. One table saw with motor.
2. Two extension wings (the right extension wing is pre-installed).
3. One blade guard and splitter with anti-kickback pawls.
4. One riving knife (pre-installed).
5. One 10 inch saw blade.
6. One zero-clearance table insert.
7. One brake cartridge for a 10 inch blade.
8. One brake cartridge key.
9. One miter gauge.
10. Two blade wrenches.
11. Three hex key wrenches.
12. One plastic bag containing assembly hardware.
13. Two Bypass Switch Keys.
14. One owner's manual.
15. Two hand wheels (the handle on the tilt hand wheel is not pre-installed)

Other accessories such as a fence and rails, an extension table, extra brake cartridges, etc., are packaged separately.

Get to Know Your Saw

The major components of your saw are identified below. Make sure you can identify these components in order to follow the instructions in this manual.

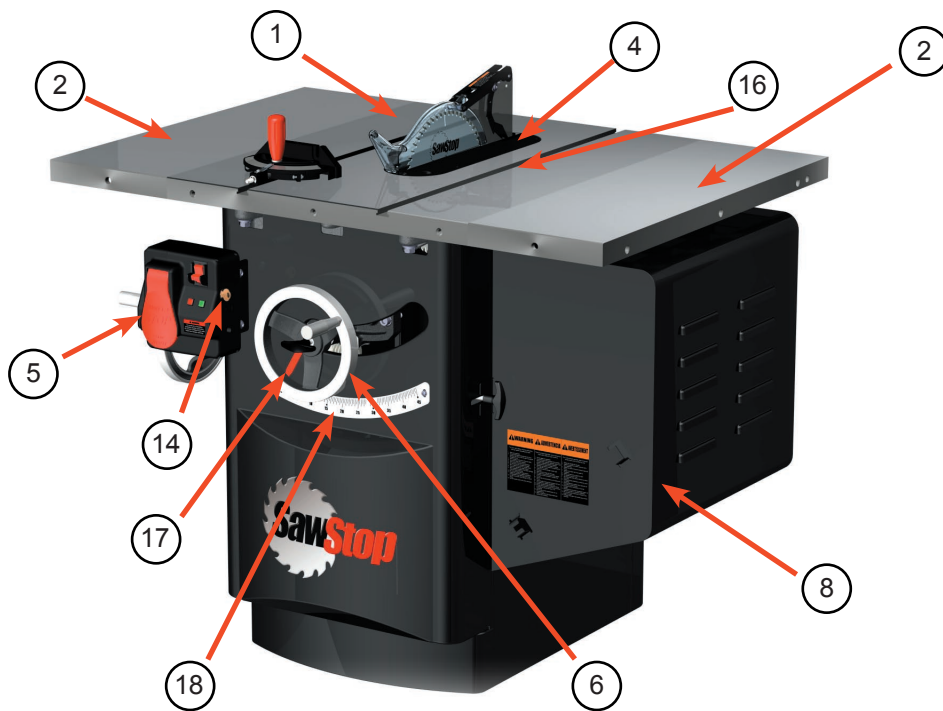

Fig. 2

External Components

1. Table Top
2. Extension Wings
3. Blade Guard
4. Standard Table Insert
5. Switch Box
6. Elevation Hand Wheel
7. Tilt Hand Wheel
8. Motor Cover
9. Terminal Box
10. Dust Port
11. Miter Gauge
12. Blade Wrenches (2)
13. Belt Access Door
14. Bypass Key
15. Spreader / Riving Knife Storage Pin
16. Miter Gauge Slots
17. Tilt Angle Indicator
18. Tilt Angle Scale
19. Disconnect Switch

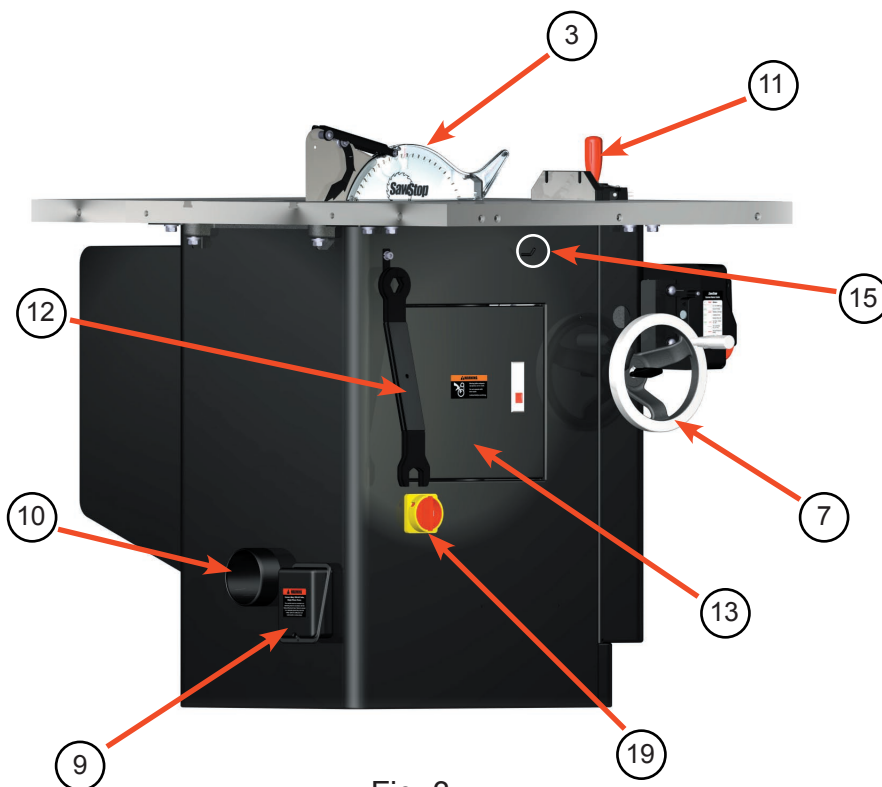

Fig. 3

Get to Know Your Saw

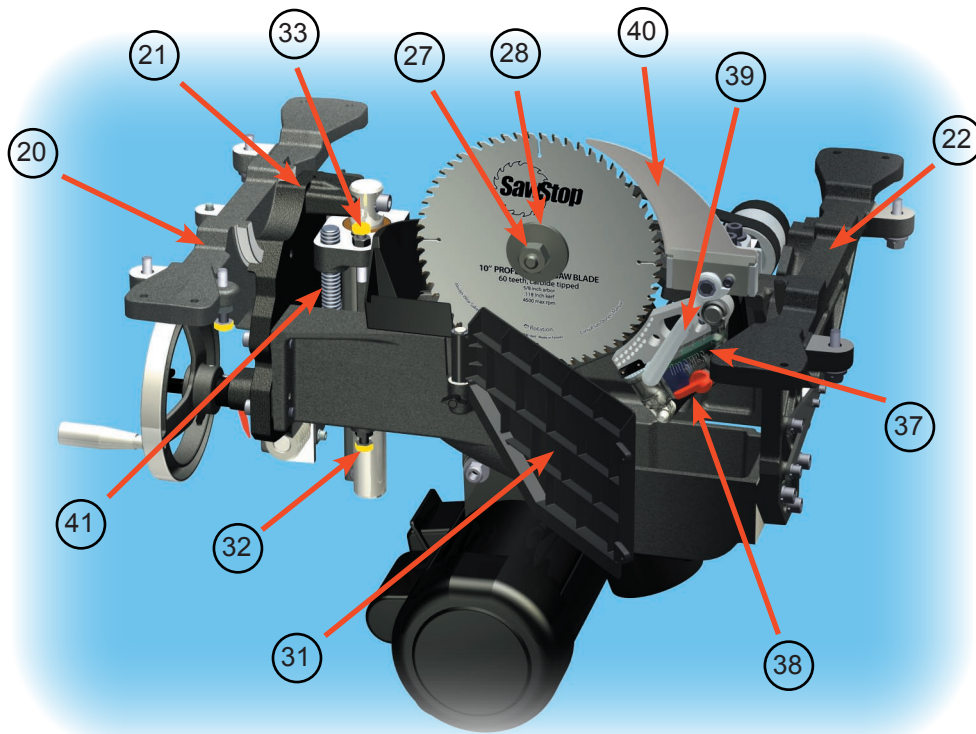

Fig. 4

Internal Components

- 20. Front Trunnion Bracket
- 21. Front Trunnion
- 22. Rear Trunnion Bracket
- 23. Rear Trunnion
- 24. Elevation Plate
- 25. Motor
- 26. Arbor Block
- 27. Arbor Nut
- 28. Arbor Washer
- 29. Arbor Belt
- 30. Motor Belt
- 31. Dust Shroud Door
- 32. Upper Elevation Limit Bolt
- 33. Lower Elevation Limit Bolt
- 34. 0° Tilt Limit Bolt
- 35. 45° Tilt Limit Bolt
- 36. Brake Positioning Bolt
- 37. Brake Cartridge
- 38. Cartridge Key
- 39. Spreader / Riving Knife Clamping Handle
- 40. Riving Knife
- 41. Elevation Threaded Rod

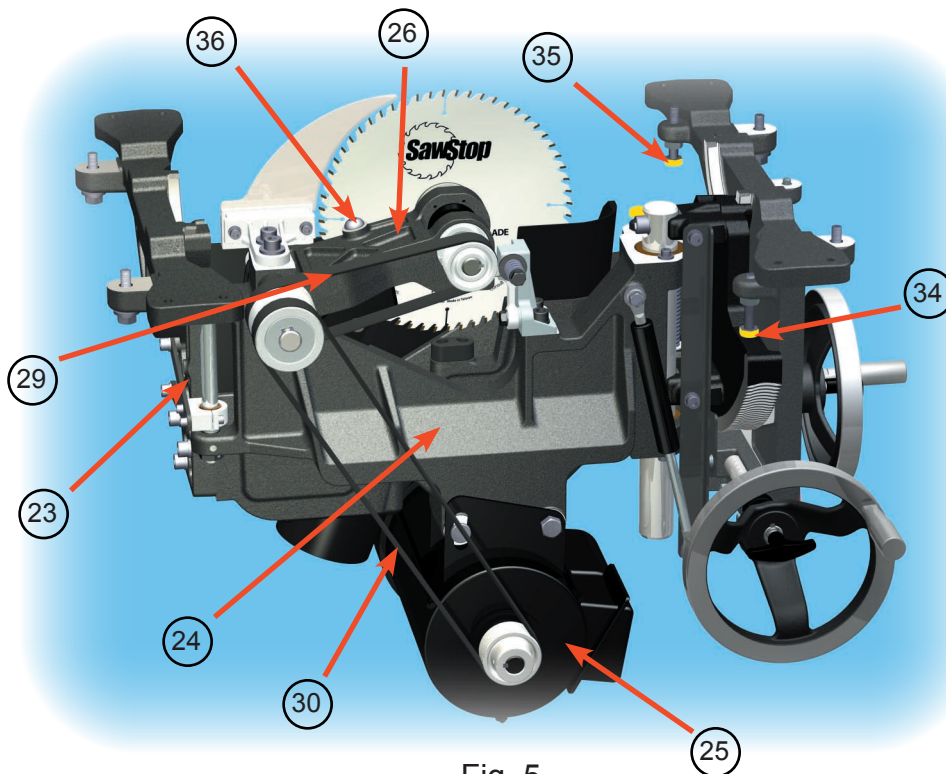

Fig. 5

Cabinet Saw Specifications

Overall saw dimensions:	44" w x 34" d x 34" h 69 1/4" w x 36 1/2" d x 34" h (w/ optional fence & 36" rails) 85 1/4" w x 36 1/2" d x 34" h (w/ optional fence & 52" rails)
Cabinet footprint:	20" w x 25" d
Cast iron table:	24" w x 30" d, 44" w x 30" d (w/ extension wings)
Extension wing:	10" w x 30" d
Extension table (optional):	24" w x 30" d (36" rails), 40" w x 30" d (52" rails)
Weights (may vary with motor):	530 lbs (table saw only) 635 lbs (w/ optional fence, 36" rails & table) 685 lbs (w/ optional fence, 52" rails & table)
Shipping weight (approx.):	640 lbs (table saw only)
Blade:	60-tooth, professional grade, 5/8" arbor
Blade diameter:	10"
Blade tilt:	Left
Blade kerf:	3 mm
Blade plate thickness:	2 mm
Max. depth of cut, blade at 0°:	3 1/8"
Max. depth of cut, blade at 45°:	2 1/4"
Max. rip, right of blade:	52 1/2" (w/ optional 52" rails) 36 1/2" (w/ optional 36" rails)
Max. rip, left of blade:	12 1/2"
Dado diameter:	8" (requires a separate brake cartridge)
Dado max. width:	13/16"
Arbor diameter at blade:	5/8"
Main bearing size:	62 mm OD x 30 mm ID
Second bearing size:	52 mm OD x 25 mm ID
Table in front of blade (max. elevation):	11"
Table behind blade (max. elevation):	9 3/4"
Arbor Runout:	0.001" Maximum Allowable Runout
Blade Lateral Movement Over Full Elevation Range:	0.006" Maximum
Table Flatness Measured Diagonally:	0.010" Maximum Gap
Overall Table and Extension Wing Flatness:	0.025" Maximum Gap
Blade Alignment with Miter Slot:	0.010" Maximum displacement
Deviation of Miter Gauge Indexing Stops from actual:	±0.25°
Alignment between Spreader and Blade	0.010" Maximum difference
Miter slots:	T-shaped, 3/4" at top, 1" at bottom, 3/8" deep 11 1/8" center-to-center 5 1/2" (arbor flange to center of right slot)
Dust collection port diameter:	4"
Riving knife / spreader thickness:	2 mm
Blade guard:	polycarbonate, extends only 5/8" to right of blade
Standard Insert:	zero clearance, phenolic core, melamine surfaces
Dado Insert:	zero-clearance, solid hardwood
Belts:	2 V-ribbed belts— arbor belt is static dissipative
Hand Wheels	8" diameter, cast iron with chrome handle
Motor:	3 hp, 1 phase, 230 V, 50-60 Hz, TEFC 3 hp, 3 phase, 230 V, 50-60 Hz, TEFC (optional) 5 hp, 1 phase, 230 V, 50-60 Hz, TEFC (optional) 5 hp, 3 phase, 230 V, 50-60 Hz, TEFC (optional) 5 hp, 3 phase, 480 V, 50-60 Hz, TEFC (optional)

Setting Up Your Saw

1. Saw Placement:

Locate the saw on a level surface away from sources of moisture and electrical noise. Make sure there is sufficient room to allow free access to all sides of the saw.

2. Extension Wing Assembly:

The saw is shipped with the right extension wing pre-installed. Position the left extension wing next to the table, making sure the small beveled edge on the surface of the extension wing is facing forward. Insert the three M10x1.5x30 bolts (with washers and lock washers) through the holes in the side of the wing and into the threaded holes in the side of the table (see Fig. 6). Align the top of the extension wing with the table using a straight edge and then fully tighten the nuts on the bolts.

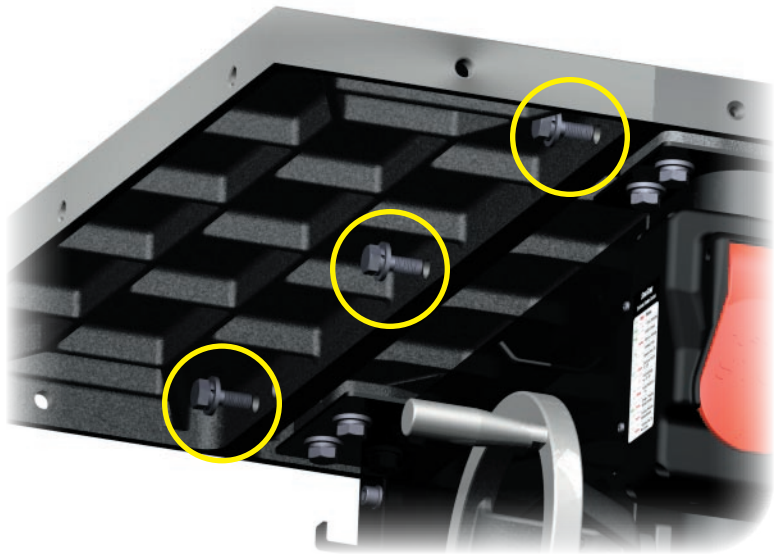

Fig. 6

3. Table and Extension Wing Cleaning:

The table and extension wings are shipped with a coating of oil on the top surfaces to prevent the cast iron from rusting. Carefully wipe the top surfaces with a soft, clean cloth to remove the oil. To prevent the top surfaces from rusting during use, you can coat the surfaces with rust-preventative materials such as TopCote® or TopSaver™, available in most woodworking stores. If the saw will not be used for an extended time, the table and wing surfaces can also be protected by applying a light coating of oil and then covering with wax paper.

4. Rip Fence Installation:

This saw ships without a rip fence. You must install a rip fence prior to using the saw. Refer to the manual that accompanied your rip fence for instructions on installing the fence on the saw.

Setting Up Your Saw

5. Tilt Hand Wheel Handle Installation:

Install the handle on the tilt hand wheel by screwing the threaded portion of the handle into the matching hole on the hand wheel (see Fig. 7). Use a wrench to tighten handle securely to the hand wheel.

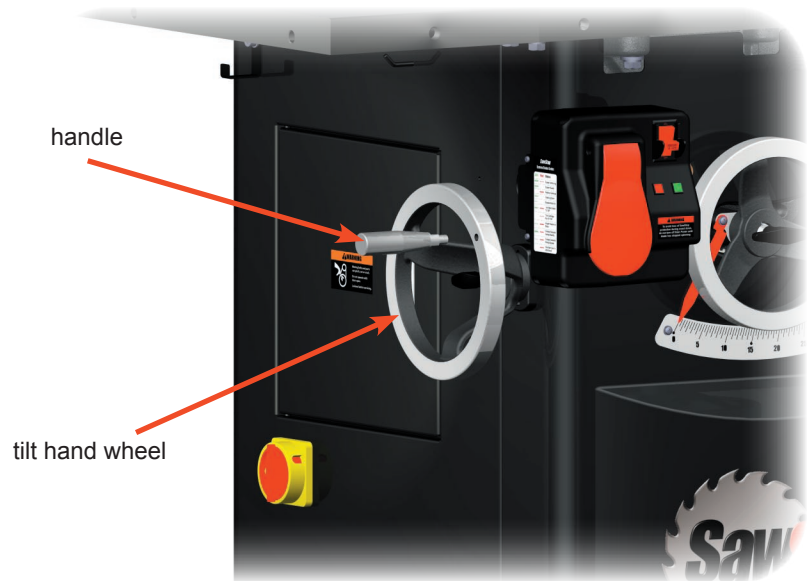

Fig. 7

6. Blade or Dado Installation:

The blade that is included with the saw is coated in oil to prevent rust during shipment. Clean this blade thoroughly before installation. If you wish to install a different blade, use a high quality blade that does not have anti-rust coatings on the teeth (e.g., lacquer, wax, etc.) Such coatings can interfere with (or potentially defeat) the ability of the system to detect contact.

To install the blade, use the open end of one of the blade wrenches included with the saw to hold the arbor behind the arbor flange, and use the closed end of the other blade wrench to loosen the arbor nut. The arbor nut is right-hand threaded so turn the nut counter-clockwise to loosen it and clockwise to tighten it. After removing the arbor nut and arbor washer, install the blade and reinstall the arbor washer and arbor nut. Use the blade wrenches to tighten the arbor nut securely (see Fig. 8).



Fig. 8

Setting Up Your Saw

Install dado sets just like you install a blade. For dado widths larger than about 3/16", remove the arbor washer and tighten the arbor nut against the dado set.

Note: if your saw uses three phase power, do not install the blade until the power supply has been connected and you have verified that the motor spins in the correct direction. See page 25 for instructions on connecting your saw to a power supply.

WARNING! Do not attempt to use saw blades made of materials that are electrically non-conductive (e.g., abrasive blades, blades with plastic hubs, etc.). The SawStop® safety system will not allow the saw to operate if these blades are installed.

WARNING! Never install the blade backwards. The brake might not stop a blade that is installed backwards, therefore you may receive a serious injury.

7. Brake Position Adjustment:

It is important to make sure that the brake cartridge is close to, but not touching, the edge of the blade to minimize the time it takes the safety system to stop the blade in the event of an accident. The spacing between the brake cartridge and the blade should be checked whenever the blade or brake cartridge are changed. To adjust the brake positioning, set the tilt angle to 0 degrees and adjust the blade elevation to approximately 1½ inches above the table top.

The spacing between the brake cartridge and the blade is adjusted by the brake positioning bolt mounted in the top of the arbor block (see Fig. 9).

brake positioning bolt

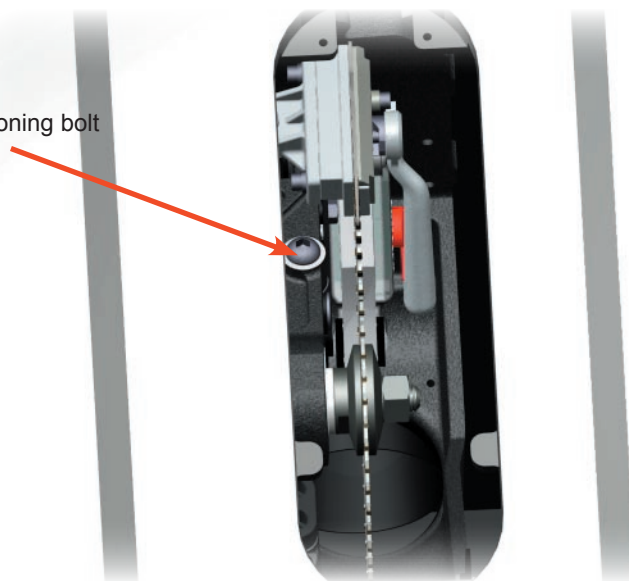
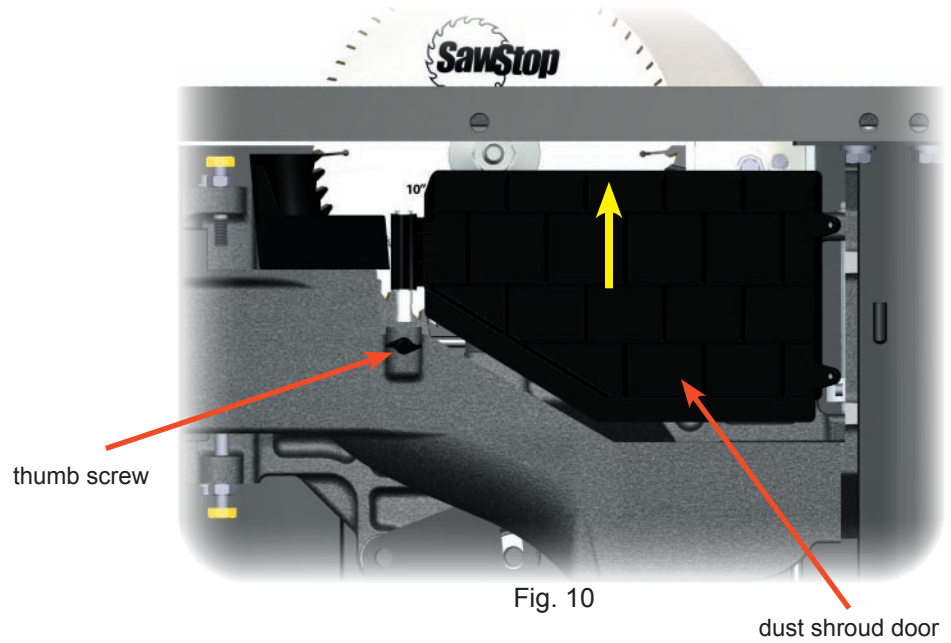

Fig. 9

Setting Up Your Saw

Note: some users may find it easier to adjust the brake position by opening the motor cover and removing the dust shroud door to see the blade and brake cartridge more clearly. To remove the dust shroud door, loosen the thumb screw and lift the door upward until the pivot pin in the door clears the pivot hole in the cast iron trunnion brace (see Fig. 10).



Using the 8 mm hex L-wrench included with the saw, turn the spacing adjustment bolt clockwise to decrease the spacing and counter-clockwise to increase the spacing. Adjust the brake position as needed to set the spacing between the teeth of the blade and the closest point on the brake cartridge to between 1/16th and 1/8th inch (see Fig. 11).

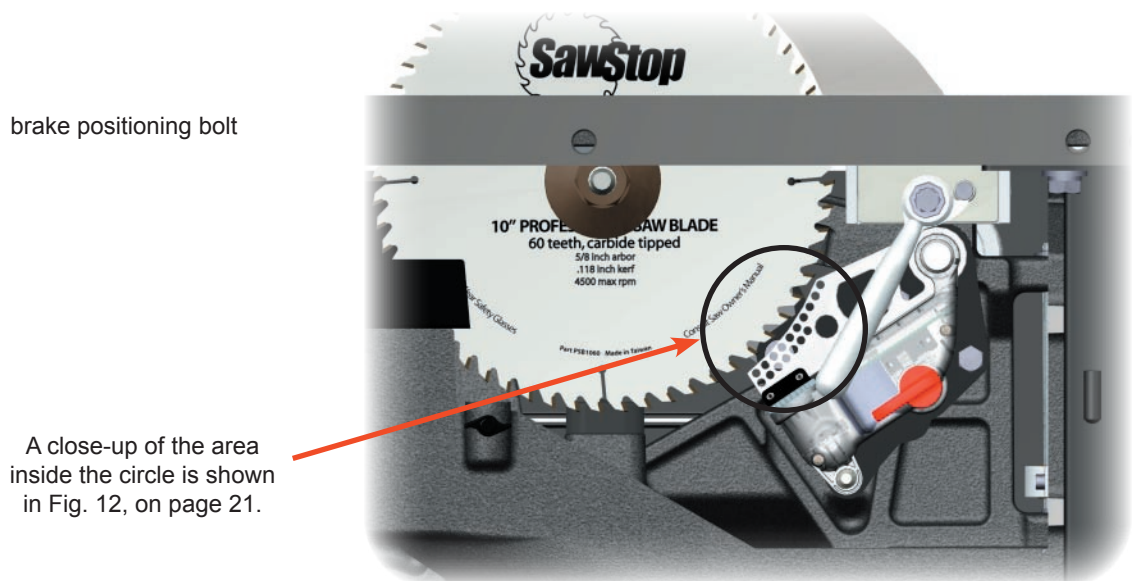

Setting Up Your Saw

A U.S. nickel can be placed between the closest points on the blade and brake cartridge to give a spacing of about 0.070 inch (approximately 1/14th inch). Spin the blade by hand at least one full revolution to verify that the blade will not hit the brake when the motor is started.

Note: When the cartridge key is installed, the brake cartridge can be moved back only about 3/16 inch from the blade. To move the brake cartridge further from the blade, first remove the cartridge key (the saw will be disabled while the cartridge key is removed). Moving the brake cartridge back more than 3/16 inch should only be necessary when changing the brake cartridge after it has been activated (see page 41).

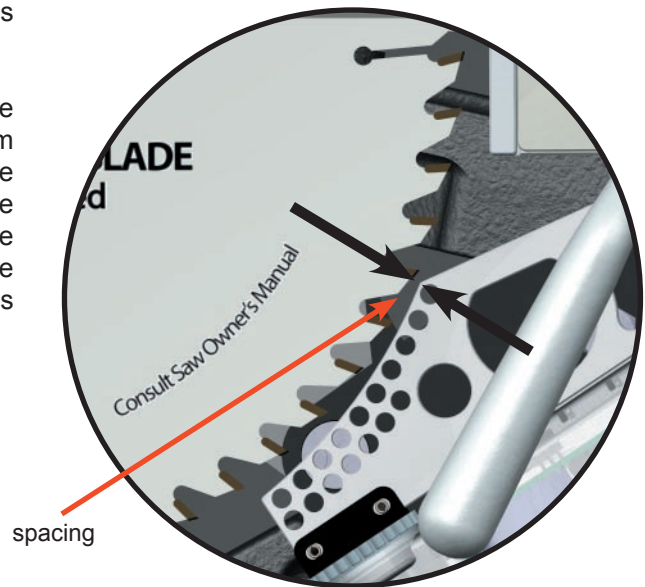

Fig. 12

CAUTION! Always spin the blade by hand after changing the blade or the brake cartridge, or after adjusting the spacing between the brake cartridge and the blade! This ensures that no part of the blade will touch the brake cartridge once the motor is started.

8. Blade Guard / Riving Knife Installation:

Your SawStop® saw includes a unique, quick-release blade guard mounting system. This mounting system was developed to allow you to quickly remove and install the blade guard and riving knife without the use of tools and without the need for realignment. The mounting system is factory-aligned to the arbor flange and should not require adjustment. If you wish to change the alignment, see page 62 for instructions.

The saw is shipped with the riving knife installed. The riving knife is an extremely important tool for reducing the potential for kickback when the blade guard cannot be used. The riving knife should always be used whenever you need to make rabbet or other non-through cuts (where the blade does not cut through the top of the wood), narrow cuts where the guard would interfere with the rip fence, and any other situations where the guard would interfere with the cut.

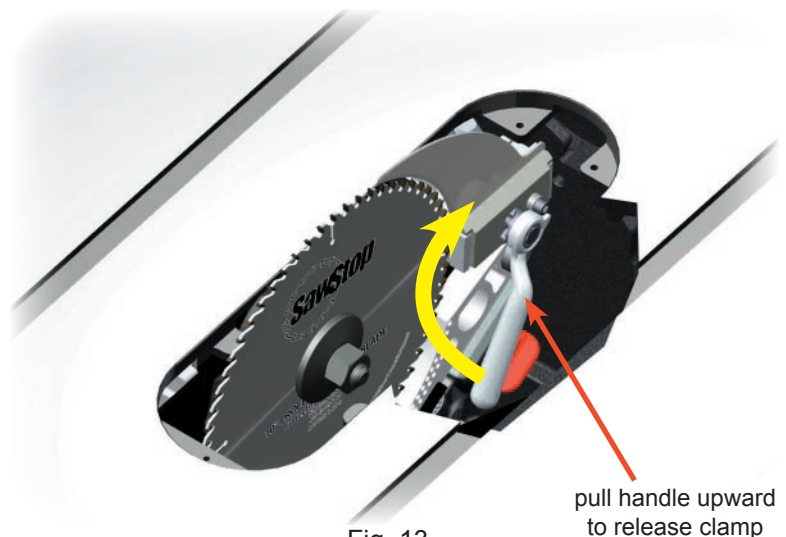

Fig. 13

Setting Up Your Saw

Note: when using a dado set, neither the blade guard nor the riving knife may be used. Instead, use other protective devices such as push sticks and featherboards.

For the majority of cuts, the blade guard should be used. To install the blade guard, first remove the riving knife by lifting the clamping handle fully upward until the clamping plate moves away from the riving knife. Then move the riving knife slightly toward the right to clear the positioning pins, and lift it out of the clamp. To install the guard, position the spreader in the clamp and flat against the base plate. The positioning pins will automatically align the spreader in the correct position. Lower the clamping handle completely until the limit shoulder is against the limit screw. If the clamping handle is difficult to lower, make sure the spreader is positioned flat against the base plate.

To remove the guard, use the same procedure as removing the riving knife. Similarly, to install the riving knife, use the same procedure as installing the guard.

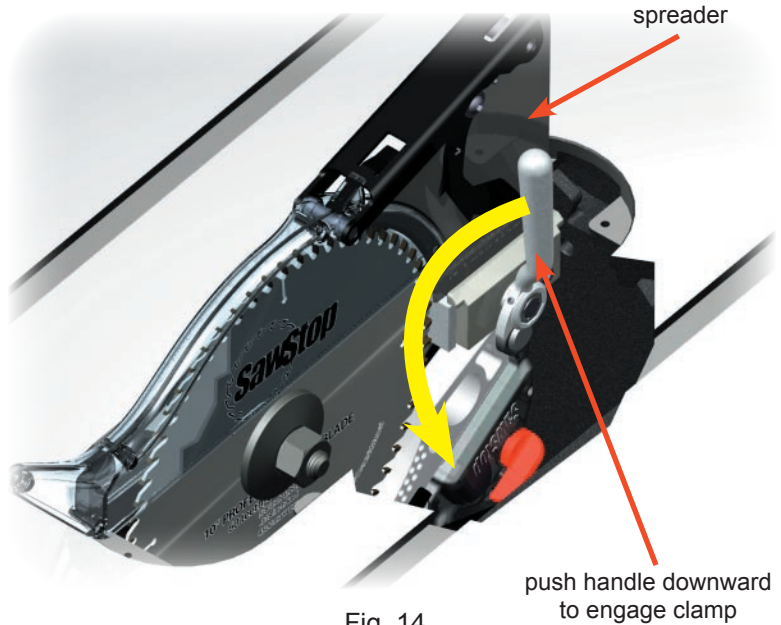

Fig. 14

WARNING! Use the blade guard and spreader for every operation for which it can be used, including all through-sawing.

For instructions on the operation and use of the blade guard and the riving knife, please see page 34.

Note: both the spreader and the riving knife are 2 mm (0.079 in) thick. Do not use a saw blade with a kerf less than 2 mm with these tools.

Setting Up Your Saw

9. Table Insert Installation:

Your saw is shipped with a high-quality, zero-clearance table insert. The insert is factory-adjusted to fit securely in the table opening and below the table surface. If you wish to perform additional adjustment on the insert, see page 61 for instructions.

To install the table insert, hold it at a slight angle, with the rear of the insert lower than the front. Slide the rear of the insert around the spreader and against the back of the table opening so that the heads of the rear lock-down screws in the bottom of the insert slide under the heads of the lock-down screws in the table opening (see Figs. 15 and 16) Then lower the front end of the insert into the table opening and use the included 3 mm hex L-wrench to tighten the front lock-down screw.

Note: when the blade guard is installed, it may be necessary to raise the elevation of the blade to allow the anti-kick pawls to clear the opening in the table and rest against the wear plates.

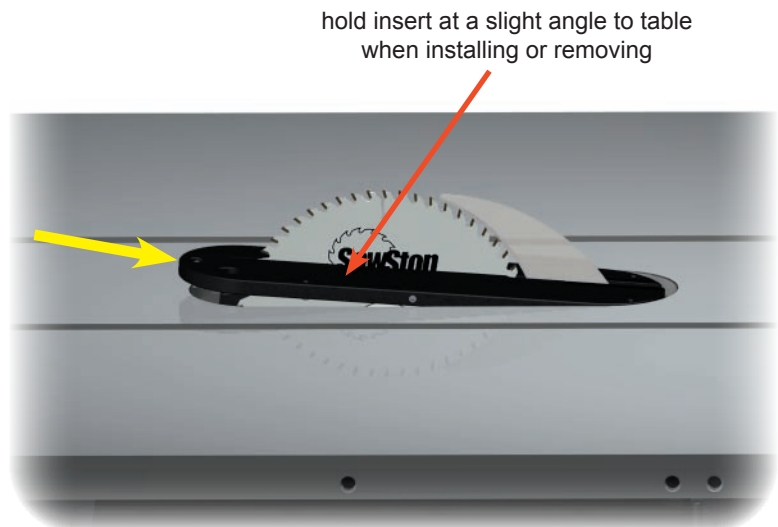

Fig. 15

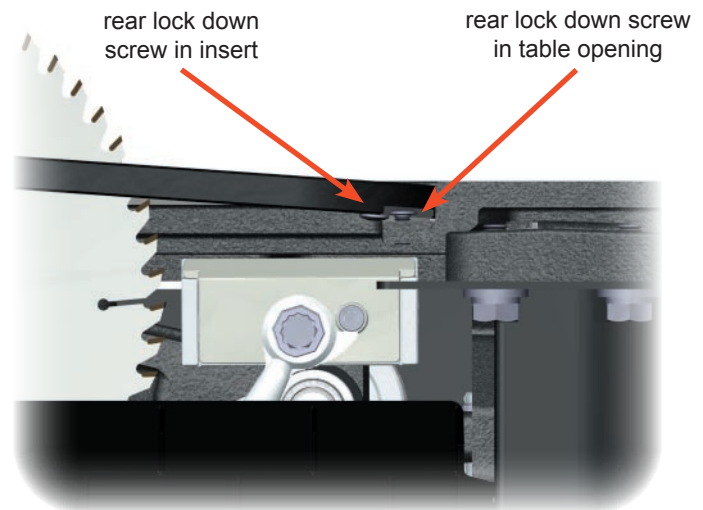

Fig. 16

WARNING! Never operate the saw without the table insert in place.

CAUTION! Do not use table inserts made of metal or other electrically-conductive materials. This can cause the brake to be activated unnecessarily.

Setting Up Your Saw

10. Connection of Dust Collection:

Your SawStop® saw includes a dust shroud around the blade to provide superior dust collection to ordinary saws. A flexible hose connects the dust shroud to a 4 inch diameter dust port on the exterior of the cabinet (see Fig. 17). It is important to connect a suitable dust collection system to the dust port on the exterior of the cabinet. All table saws generate a substantial amount of the dust, which can be a serious physical hazard.

SawStop recommends the use of a dust collection system that provides at least 350 CFM of flow at the dust port.

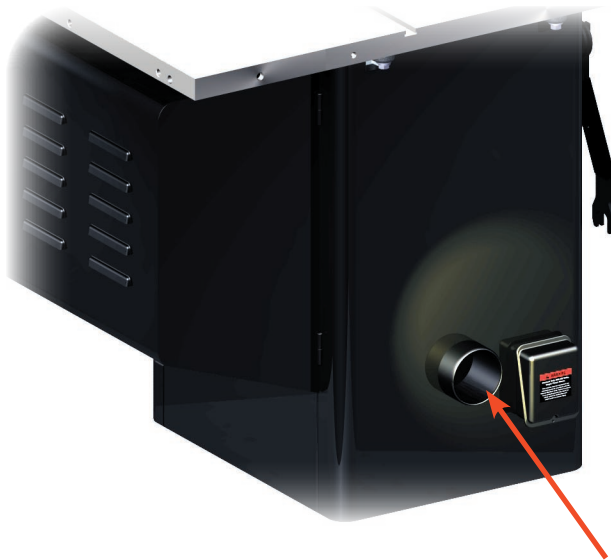

Fig. 17

4" dust collection port

WARNING! Some dust created by sawing, power sanding, grinding, drilling, and other construction activities contains chemicals known to cause cancer, birth defects or other reproductive toxicity or harm. Some examples of these chemicals are lead from lead-based paints, crystalline silica from bricks, cement, and other masonry products, and arsenic and chromium from chemically treated lumber.

In addition, wood dust has been listed as a known human carcinogen by the U.S. government.

The risk from exposure to these chemicals and to dust varies depending on how often you do this type of work. To reduce your exposure, work in a well ventilated area and work with approved safety equipment including dust masks or respirators designed to filter out such dust and chemicals.

Setting Up Your Saw

11. Electrical Power Connection:

This saw is shipped without a cord. This saw must be permanently connected to the building electrical system in accordance with the National Electrical Code and any other applicable state and local codes. Extension cords should not be used with this saw. Consult a licensed electrician if you are unsure how to properly connect this saw to the building electrical system.

WARNING! do not connect the saw to electrical power until the saw is completely assembled and you have read and understood this entire manual.

All electrical connections must be made to the terminal box on the rear exterior of the cabinet (see Fig. 18). The specification label located just above the terminal box indicates the type of power supply (i.e., voltage, current and phase) required. Attempting to operate the saw on a power supply different than specified on the specification label will void all warranties and may result in serious injury as well as damage to, or a malfunction of, the saw or safety system.

Do not make any connections to the disconnect switch box or the magnetic contactor box mounted inside the cabinet. The magnetic contactor box is sealed against tampering. The destruction, removal or alteration of the seal will void all warranties.



terminal box

Fig. 18

Note for Saws using Three Phase Power:

when connecting this saw to a three phase power supply, you must test the motor to verify it spins in the correct direction before installing a blade. However, the safety system normally prevents the motor from spinning without a blade installed. To safely test the direction of motor spin, first make sure that no blade is installed. Next, insert the Bypass key in the Bypass switch, turn the key clockwise and hold for a few seconds. The system will briefly pulse the power to the motor so that the direction of motor spin can be determined. The arbor should spin counter-clockwise when viewed from the right side of the saw. See page 75 for electrical schematics of this saw.

WARNING! do not install a blade on saws using three phase power until the motor has been verified to spin in the correct direction. If the motor spins backward with a blade installed, the arbor nut may spin off the arbor, which could allow the blade to spin off the arbor and cause a serious injury.

WARNING! this saw must be connected to a grounded metal permanent wiring system; or to a system having an equipment-grounding conductor. Failure to connect this saw to an adequate electrical ground may cause the safety system to malfunction and could result in a serious injury or electric shock.

Setting Up Your Saw

11. Disconnect Switch:

The saw is equipped with an electrical disconnect switch mounted on the left side of the cabinet. When the disconnect switch is switched to OFF (see Fig. 19), electrical power is physically disconnected from both the SawStop safety system and the magnetic contactor box. The disconnect switch should be switched to OFF whenever performing any adjustments, maintenance or repairs to the saw, including changing blades, installing or removing the blade guard and riving knife, etc.



Fig. 19

In addition, the disconnect switch can be locked in the OFF position with a padlock or similar device as shown in Fig. 20. The disconnect switch should be locked in the OFF position whenever there is a possibility of someone accidentally applying power to the saw while adjustments, maintenance or repairs are being made.



Fig. 20

When the saw has been completely installed and is ready for use, turn the disconnect switch to ON as shown in Fig. 21.

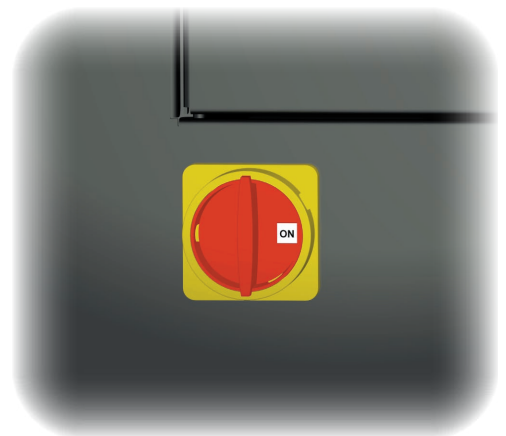

Fig. 21

Using Your Saw

1. Adjusting the Blade Height:

The height of the blade can be adjusted from $1/8$ " below the table top to $3 1/8$ " above the table top. To adjust the height of the blade, loosen the elevation locking knob and turn the elevation hand wheel until the blade is at the desired height (see Fig. 22). Turn the hand wheel clockwise to raise the blade, and counter-clockwise to lower the blade. Lock the blade height by tightening the elevation locking knob.

For through-cuts (i.e., cuts where the wood is cut through its entire thickness), the blade height should be adjusted so that the top of the blade is no more than $1/8$ " to $1/4$ " above the workpiece.

The saw includes limit stops to prevent the height of the blade from being adjusted past the maximum and minimum setpoints. These limit stops are pre-set at the factory and should not need adjustment. If you wish to adjust the blade elevation limit stops, see page 57 for instructions.



Fig. 22

CAUTION! when adjusting the height or tilt angle of the blade, reverse the hand wheel slightly to release tension after reaching the limit stops. This prevents any slight twisting of the cast iron assembly that might affect blade parallelism and table alignment.

2. Adjusting the Blade Tilt Angle:

The tilt (bevel) angle of the blade can be adjusted between 0 and 45 degrees. To adjust the tilt angle of the blade, loosen the tilt locking knob and turn the tilt hand wheel until the blade is at the desired angle. The tilt angle of the blade is indicated by the position of the tilt angle indicator on the tilt angle scale (see Fig. 23). Turn the tilt hand wheel clockwise to increase the tilt angle, and counter-clockwise to decrease the tilt angle. Lock the tilt angle by tightening the tilt locking knob.

The saw includes limit stops to prevent the tilt angle of the blade from being adjusted past the 0 and 45 degree setpoints. These limit stops are pre-set at the factory and should not need adjustment. If you wish to adjust the blade tilt limit stops, see page 59 for instructions.



Fig. 23

Using Your Saw

3. Turning on Main Power and Starting the Motor:

Your *SawStop*® saw is equipped with an Electrical Disconnect Switch to supply power to the saw, a Main Power Switch to supply power to the *SawStop*® safety system, and a Start/Stop paddle to turn the motor on and off. Both the Main Power switch and the Start/Stop paddle are mounted on the Switch Box, which is located just below the front edge of the table and to the left of the elevation hand wheel (see Fig. 24). The Switch Box also includes red and green LED's that display the current status of the safety system and saw. A label describing the System Status LED displays is positioned on the side of the Switch Box. In addition, the displays are described in more detail below.

WARNING! Never start the saw when the blade is in contact with the workpiece or any other object.

After ensuring that the Start/Stop paddle is in the “OFF” position (i.e., pushed in), turn the Main Power Switch to the “ON” position by flipping the toggle upward. This will turn on power to the *SawStop*® safety system, which will run through a brief initialization routine to test whether the system is operating properly. During this initialization period (approximately 5–10 seconds), the LED's will blink in different patterns as the safety system steps through various self-check steps. Once the safety system completes the initialization routine, the LED's will display the “READY” status display (green LED on solid, red LED off). The saw is now ready for use.

If the READY status is not displayed after 15 seconds, the safety system has detected an error that must be corrected before the saw can be used. See page 30 for a key to the LED status codes and an explanation of the error detected for each code.

To start the motor, pull the Start/Stop paddle out. To stop the motor, push the Start/Stop paddle in. The paddle is designed so that it can be pushed in by the operator's upper leg or knee in an emergency.

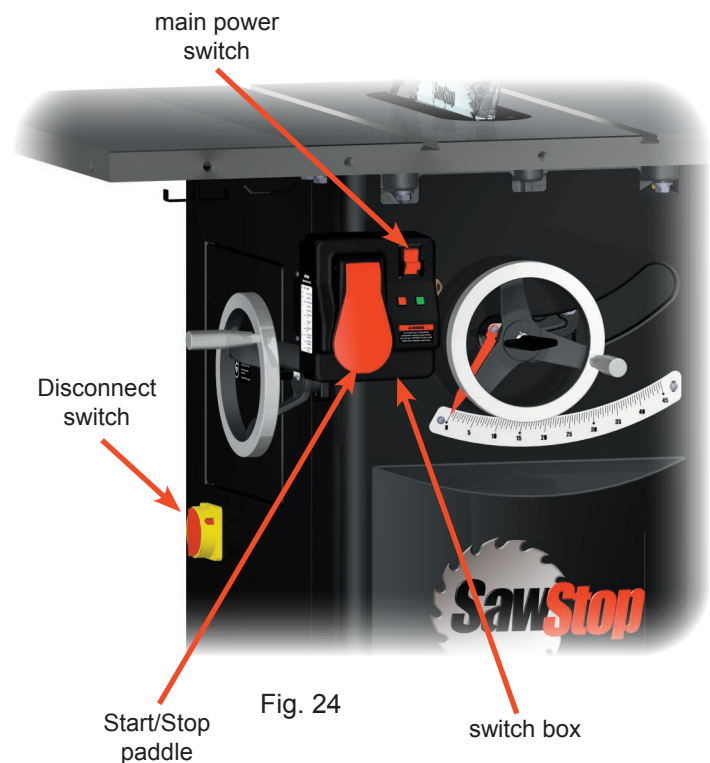

Fig. 24

WARNING! Never switch the Disconnect Switch or the Main Power Switch to OFF until the blade has come to a complete stop. In the event of accidental contact with the blade during coast down, the safety system will not activate if the Main Power has been switched OFF, and a serious injury could result.

Using Your Saw

It is not necessary to turn off the Main Power switch after turning off the motor. If you plan to make several cuts with the saw, you can leave the Main Power Switch in the **On** position between cuts to eliminate the delay due to the initialization routine. Once you have finished using the saw turn the Main Power Switch to **OFF** to reduce the likelihood of inadvertent start-up.

In addition, you can remove the key on the Main Power switch to prevent children or other non-authorized users from turning the saw on. To remove the key, pull it out, away from the switch. To replace the key, press it back into the socket until it snaps into place (see Fig. 25). When the key is removed, the Main Power Switch can be turned **OFF**, but it cannot be turned **ON**.



Fig. 25

Using Your Saw

4. System Status Codes:

In the event that the safety system detects an error, the LED's on the Switch Box will display a status code to indicate what error has been detected. Table 1 shows the different status codes which can be displayed. A complete description of each status code and the necessary corrective action is provided below.

















System Status Codes		
Green LED	Red LED	Status
		System Initializing
		System Ready
		Replace the Brake Cartridge
		Blade is Coasting Down
		Bypass Mode is ON
		Switch the Start/Stop Paddle to OFF
		Turn the Cartridge Key to ON
		Adjust Position of the Brake Cartridge
		Contact was Detected During Standby
		Contact was Detected During Bypass
		Overload Due to Wet Wood

Table 1

 Green LED blinks fast

 Red LED blinks fast

 Green LED blinks slowly

 Red LED blinks slowly

 Green LED is on solid

 Red LED is on solid

WARNING! Always turn the Main Power Switch to **OFF** and disconnect the saw from the power supply before changing the blade or performing any other adjustments or maintenance to the saw.

Using Your Saw

System Initializing — this code indicates that the system is performing self-checks and charging the brake system to fire in the case of an accident. This condition should clear within 15 seconds after the Main Power Switch is turned on.

If the ambient temperature is very low (below about 0° F), this code may take longer to clear. The safety system detects such low temperatures within the brake cartridge. If necessary, the system turns on a heater inside the cartridge to raise the temperature of the electronics. This code will continue until the temperature inside the brake cartridge is within the normal operating range.

System Ready — this code indicates that all self-checks have been completed, the safety system is operating properly, and the saw is ready to run.

Replace the Brake Cartridge — this code indicates that the cartridge has already been fired or there is some other permanent defect that cannot be corrected. If the cartridge has not been fired, try turning off the Main Power and turning it back on. If the error continues, the cartridge must be replaced.

Blade is Coasting Down — this code indicates that the blade is coasting down and that the safety system is ready to activate the brake if contact is detected. The safety system detects the rotation of the motor to determine when the blade is coasting down. If you touch the blade while this code is flashing, the brake will be activated.

ALWAYS MAKE SURE THE BLADE HAS COME TO A COMPLETE STOP AND THE COAST DOWN STATUS CODE HAS CLEARED BEFORE TOUCHING THE BLADE!

Bypass Mode is ON — this code indicates that the saw is running in Bypass Mode and **will not** activate the brake in the event of accidental contact with the blade. Bypass Mode allows you to cut electrically conductive materials such as aluminum without activating the brake. When the saw is in Bypass Mode, the safety system disables the brake. See page 33 for instructions on how to turn the saw on in Bypass Mode.

Switch the Start/Stop Paddle to OFF — this code indicates that the Start/Stop paddle was left in the *ON* position (i.e., pulled out). Push the paddle in to the *OFF* position to clear this error. This is a safety feature to prevent the saw from restarting after a power loss or after the safety system has turned the saw off due to an error detected during use.

Turn the Cartridge Key to ON — this code indicates that the cartridge locking key is not turned to *ON*. To clear this error make sure the cartridge locking key is correctly installed and turned to *ON*. See page 41 for instructions on how to install and turn on the cartridge locking key.

Adjust Position of the Brake Cartridge — this code indicates that the blade is too far from the aluminum brake pawl. To clear this error, adjust the position of the brake cartridge as described on page 19. This error code will also be displayed if there is no blade installed, if a blade smaller than 10" is installed, or if a non-conductive blade (e.g. abrasive blade) is installed.

Contact was Detected During Standby — this code indicates that the safety system detected contact with the blade (or a portion of the arbor) when the blade was not spinning. This is an error that will be displayed if you come into contact with the blade or arbor while the system is in Standby mode. The brake will not be activated and the error will automatically clear within 5 seconds after contact is ended. The system will not allow the motor to start while this error is occurring.

Using Your Saw

Contact was Detected During Bypass — this code indicates that contact was detected while the saw was running in Bypass Mode. As described above, the brake will not be activated during Bypass but the safety system will continue to monitor for contact. If this code is displayed, then it indicates that the brake would have activated if the system had not been in Bypass Mode. This error will automatically clear once the blade has finished coasting down.

This code allows you to “test” a particular material to see if it is too conductive to cut during normal operation. For example, if you have a new material you need to cut and are not sure if it is conductive, you can make several cuts in Bypass Mode. If this error code is displayed, then it means the material is too conductive and must be cut in Bypass Mode to prevent false trips of the brake. If the error code is not displayed then it is likely that the material is not conductive and you can make future cuts in normal mode. (See page 33 for instructions on how to operate the saw in Bypass Mode.)

Overload Due to Wet Wood — this code indicates that the wood being cut is too wet or too green. Very wet or green wood can interfere with the safety system’s ability to detect contact. The system monitors for wet and green wood and, if the wood is too wet or too green, the system will shut off the motor and display this error code. **To clear this error, turn the Start/Stop paddle to OFF and turn the Main Power to OFF and then back to ON.**

The wood should be set aside to allow it to dry before continuing the cut. If necessary, you can cut the wood in Bypass Mode to prevent this error. (See page 33 for instructions on how to operate the saw in Bypass Mode.)

Using Your Saw

5. Using the Saw in Bypass Mode:

If you need to cut electrically conductive materials such as aluminum with this saw, you must operate the saw in Bypass Mode to prevent the brake from being activated. To ensure that the saw is never placed in Bypass Mode accidentally, the safety system requires you to precisely follow the procedure below to turn on the saw in Bypass Mode.

To Operate the Saw in Bypass Mode:

- Turn the Bypass Key clockwise and hold it for at least 1 second (see Fig. 26). *Note: to prevent unauthorized use of the saw in Bypass Mode, remove the Bypass Key from the saw when not in use.*
- While holding the Bypass Key turned, pull the Start/Stop paddle out to the ON position. The blade will start to spin and the Bypass Mode status code will flash on the LED's.
- Continue to hold the Bypass Key turned for at least 1 second after the motor starts. If you release the Bypass key before the 1 second has elapsed, the motor will stop and the "Switch Start/Stop Paddle to OFF" error code will be displayed. If this happens, switch the Start/Stop paddle to OFF and repeat this procedure from the beginning.

Note: the safety system cannot be placed in Bypass Mode unless the brake cartridge is properly installed and all error codes are cleared.



Fig. 26

WARNING! Never run the saw in Bypass Mode unless necessary to cut conductive materials. The brake system will not activate when the saw is in Bypass Mode and a serious injury could result.

Using Your Saw

6. Using the Blade Guard:

Using the blade guard is one of the most important steps you can take to prevent injury when using your saw. Most table saw injuries occur when the blade guard is either not being used or not being used properly. Your SawStop saw is equipped with a narrow profile blade guard that allows you to use the rip fence when making narrow rip cuts. As a result, there are only a few situations where the blade guard cannot be used (e.g., dado cuts, rabbet cuts, and extremely narrow cuts). For all other situations, use the blade guard as described below.

Install the blade guard as described on page 21. The guard shell is mounted on a pivot arm that allows the guard to automatically adjust to the height of the workpiece (up to 3 1/8 inches high). The pivot arm also allows the guard shell to be pivoted upward to a balance point where the guard will rest without further support. This allows you to adjust or change the blade without removing the guard.

To use the guard, set the blade elevation and tilt angle to the desired settings. If necessary, swing the pivot arm down to ensure the guard is resting on the table or insert. Cut the workpiece as described beginning on pages 37. The guard will “float” on the top of the workpiece as it passes under the guard. The guard shell is constructed of clear polycarbonate to allow you to clearly see the blade and the workpiece as it passes under the guard. After making the cut, the cut-off portion of the workpiece may be held beneath one of the anti-kickback pawls. In this case, turn off the motor and wait until the blade completes coast-down before pushing the cut-off portion past the anti-kickback pawl.

Keep the guard shells clean and free of dust to allow unobstructed viewing of the blade and workpiece. For successful operation, the spreader must remain flat, and the guard shells, pivot arm and anti-kickback pawls must pivot freely. If any portion of the guard ceases to function properly, replace or repair it before continuing to use the saw. When not in use, the blade guard can be stored on the guard / riving knife storage pin on the left side of the cabinet (see Fig. 3).

blade guard and spreader assembly



Fig. 27

WARNING! Use the blade guard and spreader for every operation for which it can be used, including all through-sawing.

Using Your Saw

7. Using the Riving Knife:

The riving knife should be used whenever the blade guard cannot be used. The only operation where neither the guard nor the riving knife can be used is making dado cuts. To use the riving knife, remove the blade guard and install the riving knife as described on page 21. When the blade guard / riving knife clamping bracket is properly aligned, the riving knife will be positioned below the top of the blade and inside the kerf of the blade. As a result, the riving knife can be used even for rabbet cuts and other non-through cuts.

For successful operation, the riving knife must remain flat so that the full height of the riving knife is positioned inside the kerf of the blade. In the event the riving knife becomes bent, replace it or have it straightened before continuing to use it. When not in use, the riving knife can be stored on the guard / riving knife storage pin on the left side of the cabinet (see Fig. 3).

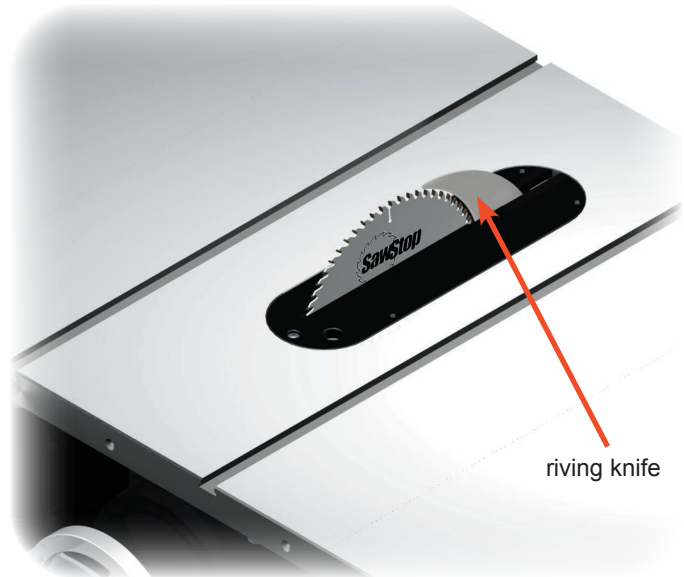

Fig. 28

WARNING! Use the riving knife for every operation where the blade guard cannot be used. Neither the blade guard nor the riving knife can be used when making dado cuts.

8. Using the Miter Gauge:

The miter gauge included with your saw allows you to easily make miter cuts and perform cross-cuts (cuts across the grain of the wood). When not in use, the miter gauge can be stored in the brackets formed on the front of the motor cover (see Fig. 29).

The main bar of the miter gauge fits in the T-shaped slots in the table which are located on either side of the blade. The miter gauge can be used in either slot; however, do not use the miter gauge in the slot on the left of the blade when making bevel cuts. Positioning the miter gauge in the left slot when making bevel cuts causes the blade to be tilted toward the miter gauge and the operator's hand which could result in a serious injury.



Fig. 29

miter gauge in storage location

Using Your Saw

A guide plate is mounted on the end of the main bar (see Fig. 30) and fits in the bottom of the slots to hold the front of the miter gauge in place when the miter gauge head is positioned in front of the forward edge of the table. Three spring bearings are mounted in the side of the main bar to ensure the bar slides smoothly in the slots without excessive play. These spring bearings are preset at the factory to allow smooth operation of the miter gauge, and should not require further adjustment. If you wish to adjust the spring bearings, see page 66 for instructions.

The face of the miter gauge can be adjusted between -60° and $+60^\circ$ relative to the blade. To adjust the miter angle, turn the handle counter-clockwise approximately $1/2$ turn to unlock the miter gauge head. Pull the indexing pin backwards until it stops, and then rotate the head until the indicator is positioned over the desired angle on the miter gauge scale. Use an angle gauge to set the angle between the miter gauge head and the blade if precise alignment is needed. Once the angle is correct, turn the handle clockwise to lock the miter gauge head.

Adjustable index stops at -45° , 0° , and $+45^\circ$ are provided to allow quick and precise alignment at those angles. To use the index stops, rotate the miter gauge head until the angle indicator reads approximately 5° higher (more positive) than the desired angle, and then push the indexing pin forward until it stops. Next, rotate the miter gauge head counter-clockwise until the index stop hits the indexing pin, and then tighten the handle to lock the gauge at the desired angle. The index stops are preset at the factory to be within $\pm 0.5^\circ$ of the true angle, so further adjustment should not be necessary. If you wish to adjust the index stops, see page 66 for instructions.

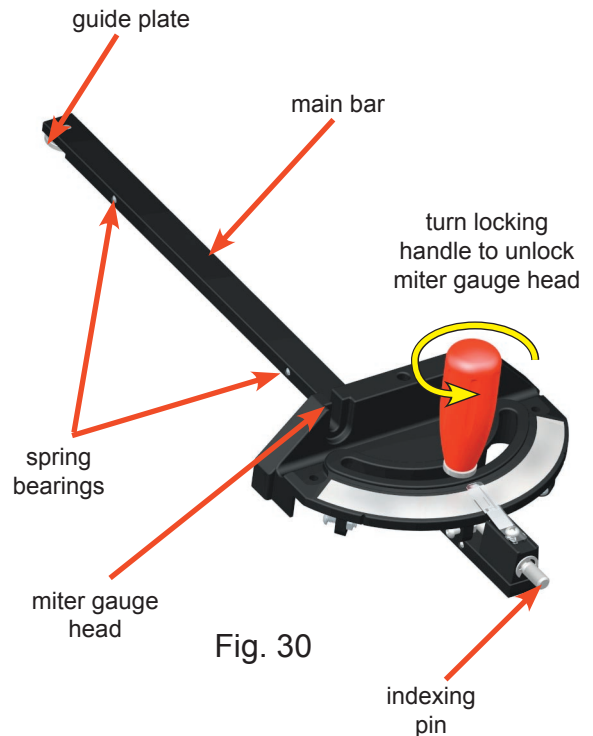

Fig. 30

For added safety, an optional wood face can be mounted to the miter gauge face to provide additional support when cutting large or small workpieces. To mount the face, use wood screws with shanks sized to fit through the slots in the miter gauge head. The wood face should be at least 1 inch higher than the maximum depth of cut, and should extend beyond the edges of the miter gauge head.

When using the miter gauge, start with the workpiece and miter gauge well in front of the blade. Place your hand closest to the blade on the miter gauge handle, and your other hand on the workpiece opposite the blade (see Figs. 31 and 32 on page 37). Make sure the workpiece is held squarely and firmly against the miter gauge face and the table. Move the miter gauge and workpiece slowly and smoothly past the blade. For through-cuts, shift the workpiece slightly away from the blade before pulling the miter gauge and workpiece back toward the front of the saw. Do not touch the portion of the workpiece that was cut off until the blade has completed coast-down.

WARNING! never make free-hand cuts. Never hold or touch an unsupported piece of wood while the blade is spinning.

Using Your Saw

9. Cross-Cutting:

Cross-cutting or cutting perpendicular to the grain of the workpiece, is performed using the miter gauge. To lessen the risk of kickback, the rip fence should be removed or positioned so that it does not contact the workpiece during cross-cutting.

To begin, make sure the motor is off and the blade is completely stopped. Tilt the blade to the desired tilt angle and adjust the blade elevation to about 1/8 inch above the workpiece. Place the miter gauge in the right miter slot for bevel cuts, or in either the right or left miter slots for making non-bevel cuts. Adjust the miter gauge to the desired miter angle (see page 35).

Position the workpiece against the miter gauge head and slowly push the miter gauge toward the non-spinning blade until the workpiece is almost touching the blade. Next, slide the workpiece to the left or right until the blade is aligned with the point on the workpiece to be cut. Pull the miter gauge and workpiece back away from the blade before starting the motor. Holding the miter gauge and workpiece firmly, move the miter gauge and workpiece slowly and smoothly past the blade. See page 35 for additional instructions on the use of the miter gauge.

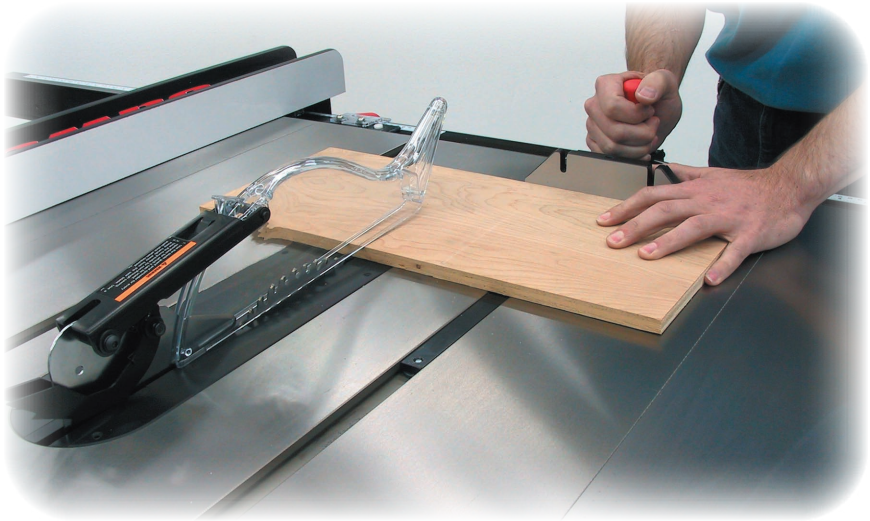

Fig. 31

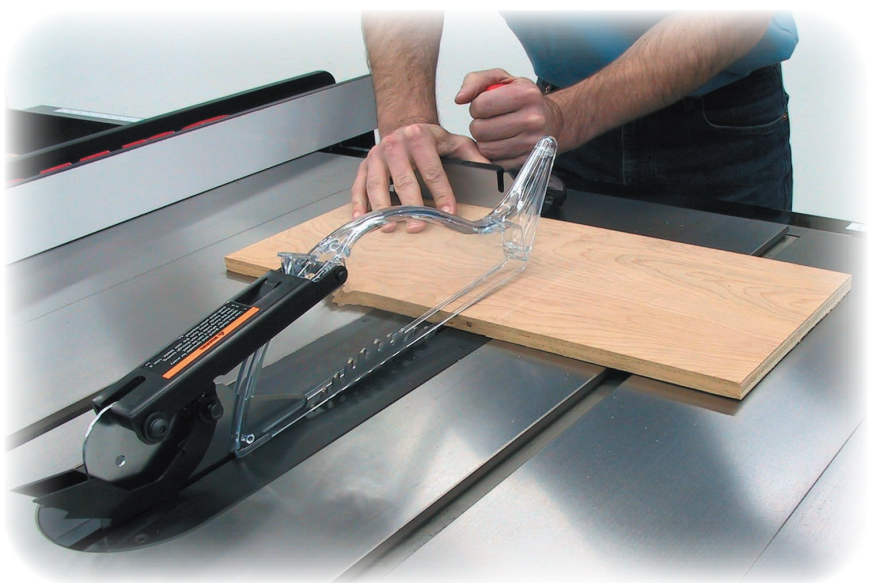

Fig. 32

WARNING! to reduce the potential for kickback and a serious injury, move the rip fence out of contact with the workpiece when cross-cutting to prevent the workpiece from binding between the rip fence and the blade..

Using Your Saw

10. Rip Cutting:

Rip cutting or cutting with the grain of the workpiece must be performed with a rip fence to support and guide the workpiece. The miter gauge should not be used when making rip cuts. The blade guard should be used for all through cuts

To begin, make sure the motor is off and the blade is completely stopped. Tilt the blade to the desired tilt angle and adjust the blade elevation to about 1/8 inch above the workpiece. Position the rip fence for the desired rip width and lock the fence in place. Refer to the owner's manual that accompanied your rip fence for instructions on operating your fence.



Fig. 33

WARNING! a rip fence must always be used when making rip cuts. Never perform a ripping operation freehand or a serious injury may result.

Position the workpiece flat on the table and flush against the side of the rip fence. Turn on the motor. Use both hands to push the workpiece smoothly toward the blade, as shown in Figs. 33 and 34. When there is approximately 12 inches remaining to be cut, remove the hand farthest from the fence away from the workpiece. If the rip cut is 6 inches or wider, continue moving the workpiece toward the blade with one hand on the workpiece and against the rip fence. For rip cuts narrower than 6 inches, always use a push stick to push the workpiece past the blade. (See page 73 for instructions on making a push stick.)

WARNING! to reduce the chance of a serious injury, always use a push stick when making rip cuts narrower than 6 inches.

Using Your Saw

Continue pushing the workpiece toward the back of the saw until it clears the anti-kickback pawls on the spreader. Turn off the motor. Do not attempt to remove the cut-off portion until the blade has come to a complete stop.

When ripping pieces longer than approximately 4 feet, use rollers, an out-feed table or a similar support to prevent the workpiece from dropping off the back of the table.



Fig. 34

When making non-through cuts, the blade guard and spreader must be removed. For these cuts, install the riving knife (except when making dado cuts) and use one or more featherboards to hold down the workpiece and help prevent kickback. (See page 74 for instructions on making a featherboard.) The featherboard should be clamped to the rip fence. Alternatively, the featherboard can be clamped to an extender board that is clamped or screwed to the rip fence as shown in Fig. 35. In the illustration, a second featherboard can be clamped to the top of the table and against the left side of the workpiece to hold the workpiece against the rip fence.



Fig. 35

Using Your Saw

WARNING! never drop or otherwise subject a brake cartridge to misuse as this may damage the brake cartridge and potentially cause the brake pawl to be released unexpectedly and result in a serious injury.

Changing the brake cartridge is both simple and foolproof. The safety system will not allow the motor to start if the brake cartridge is installed improperly. Before changing the brake cartridge, make sure the Start/Stop paddle is pushed in to the OFF position, and the Main Power Switch is toggled down to the OFF position.

The brake cartridge is mounted beneath the table and behind the blade (see Fig. 36) To change the cartridge, begin by setting the tilt angle to about 0 degrees and raising the blade elevation to close to the maximum height. This allows the easiest access to the brake cartridge.

Next, remove the table insert (see page 23) from the table, and swing the rear of the dust shroud door to the right, away from the brake cartridge. Rotate the spreader/riving knife clamping handle fully upward to provide clearance for removing the brake cartridge.

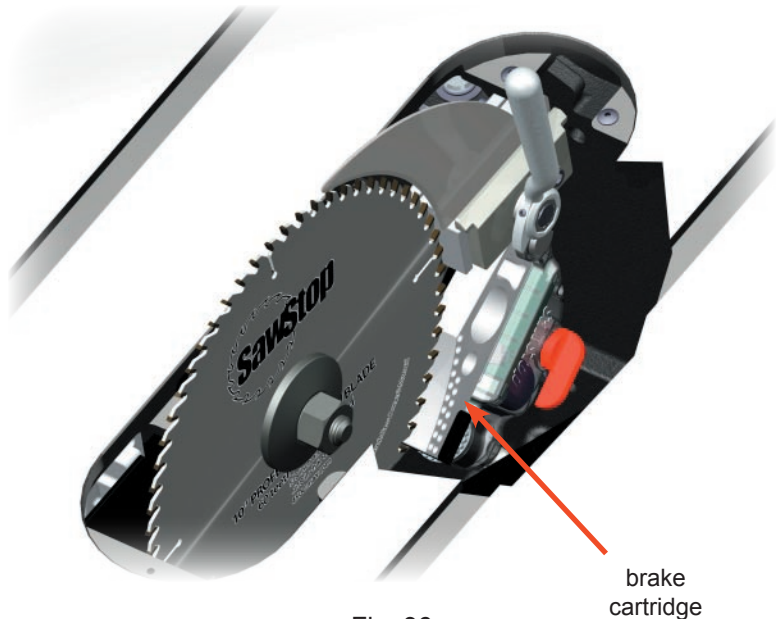

Fig. 36

WARNING! always make sure both the Disconnect Switch and the Main Power Switch are in the OFF position before removing or installing the brake cartridge.

If the brake cartridge has been actuated, the brake will be locked onto the blade or dado set and cannot be removed without the brake cartridge. In this case, leave the blade or dado set on the arbor and continue with the instructions below. If the brake cartridge has not been actuated, remove the blade or dado set from the arbor as described on page 18.

Using Your Saw

11. Changing the Brake Cartridge:

The SawStop standard brake cartridge (shown in Fig. 37) includes a sealed housing containing the SawStop system electronics, and an aluminum block called a brake pawl. The sealed housing also includes a high-speed actuator that pushes the brake pawl into the teeth of the saw blade in the event accidental contact is detected.

Like any electronic component, brake cartridges should be handled with care. Store brake cartridges in a safe, dry place when not in use. Do not drop, hit or otherwise subject brake cartridges to abuse as this may damage the cartridge. In addition, the high speed actuator could be unexpectedly triggered due to damage, thereby causing the brake pawl to be pushed away from the housing at very high speed and with a large amount of force.

Although the brake cartridge housing is sealed to inhibit the entry of dust and other debris, you should periodically check the cartridge visually for the presence of dust inside the housing as this might indicate that the seal has been damaged. The operation of the cartridge will not be affected by a small amount of dust, but you should replace the cartridge if a substantial amount of dust has begun to accumulate in the housing.

The brake cartridge must be changed whenever swapping between 10" standard blades and dado sets. For dado cuts, the optional dado brake cartridge must be installed (see Fig. 38). The SawStop dado cartridge is identical to the standard brake cartridge with the exception of the brake pawl. The dado brake pawl is larger than the standard brake pawl to accommodate the width and diameter of 8 inch dado sets. Other size dado sets or standard 10 inch blades are not compatible with the 8 inch dado cartridge. The brake cartridge must also be changed in the event the brake is activated.

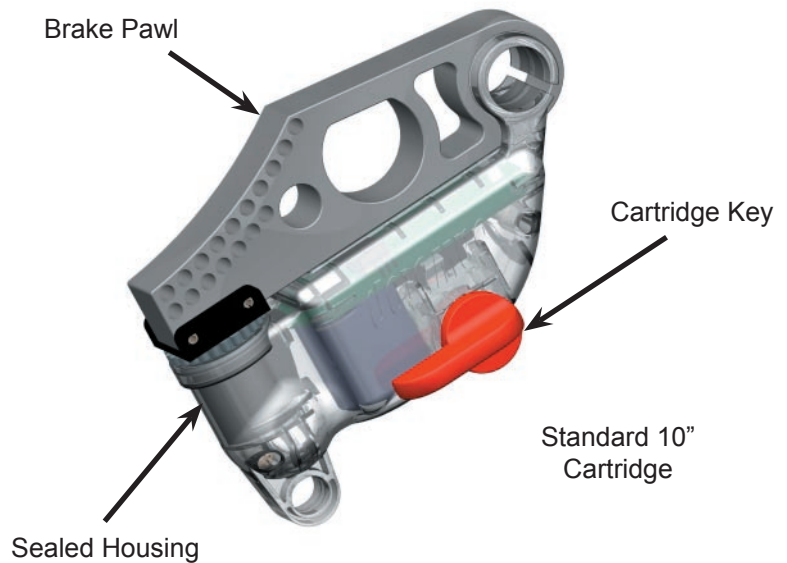

Fig. 37

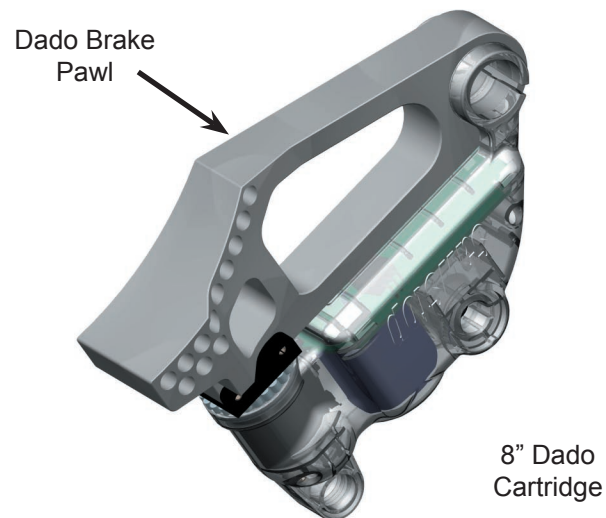
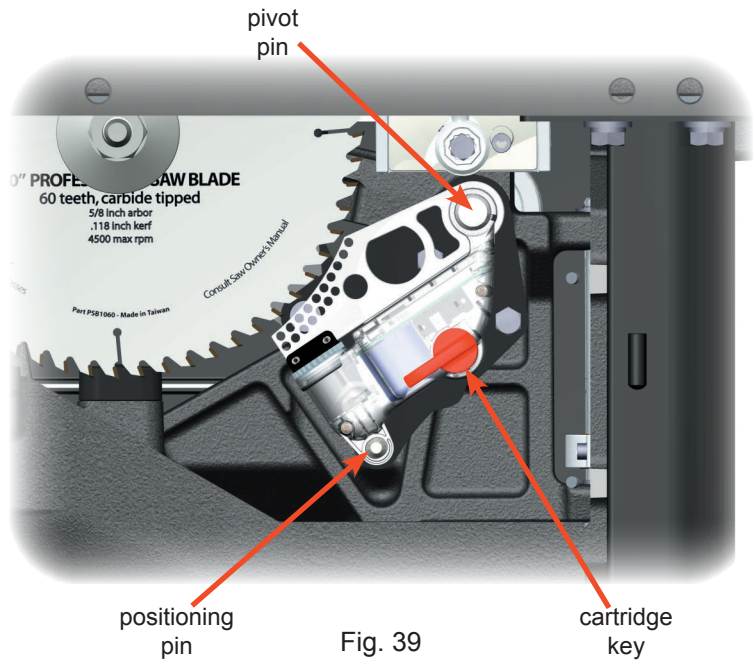

Fig. 38

Using Your Saw

You can change the brake cartridge either from the top of the saw through the table opening, or from the right side of the saw through the opening behind the motor cover. To change the cartridge from the right side, first open the motor cover. Next, remove the dust shroud door by loosening the thumb screw at the front of the door and lifting the door upward until the pivot pin clears the mounting shaft. See Fig. 10.

The brake cartridge is mounted on a large pivot pin and a positioning pin as shown in Fig. 39



The brake cartridge is locked in place by the cartridge key (see Fig. 39). Remove the cartridge key by turning the key 90° clockwise and then pulling it away from the cartridge (see Fig. 40). Set the cartridge key aside for use with the new cartridge.

It may take a small amount of force to turn the key and pull it out. Make sure you turn the key 90°, as the key cannot be pulled out unless it has been fully rotated.



Using Your Saw

To remove the cartridge from the saw, slide it to the right until it clears both pins as shown in Fig. 41.

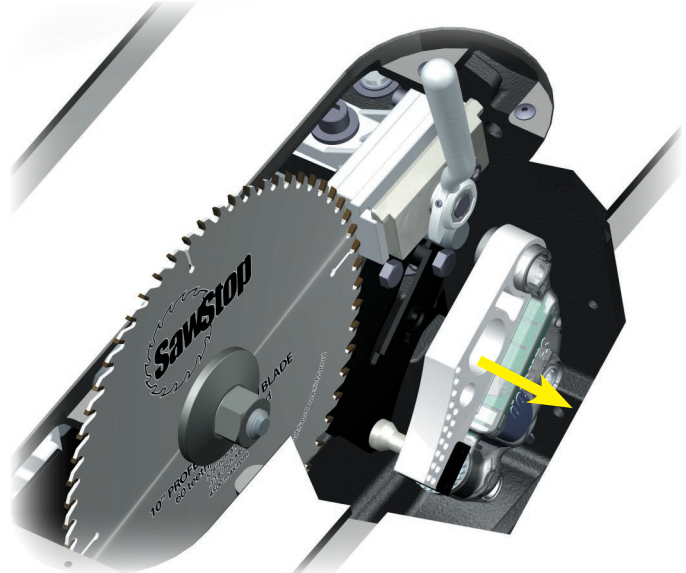

Fig. 41

If the Cartridge has been Actuated: If the cartridge is being replaced because it has been actuated, the brake pawl will be locked onto the blade or dado set. In addition, a heavy-duty spring will be pressing the brake pawl toward the blade or dado set. As a result, the blade or dado set will be more difficult to remove than usual.

It is often possible to remove both the brake cartridge and blade simultaneously by alternating moving the blade and cartridge to the right to “walk” them off the arbor and pins. If the pressure of the spring makes this too hard, you can release the pressure by rotating the brake positioning bolt counter-clockwise. This will cause the cartridge mounting bracket to move away from the blade. Once the pressure of the spring is released, you should be able to remove both the blade and the brake cartridge together.

If you continue to have trouble removing the blade and brake cartridge after the spring pressure is released, you can knock the brake off the blade so that the blade and brake cartridge can be removed separately. As shown in Fig. 42, place one end of a stick (e.g., 1” by 1/2” by 16”) along the side the blade and against the portion of the brake pawl that is locked on the blade. Using a mallet, hit the other end of the stick until the blade completely clears the brake pawl.

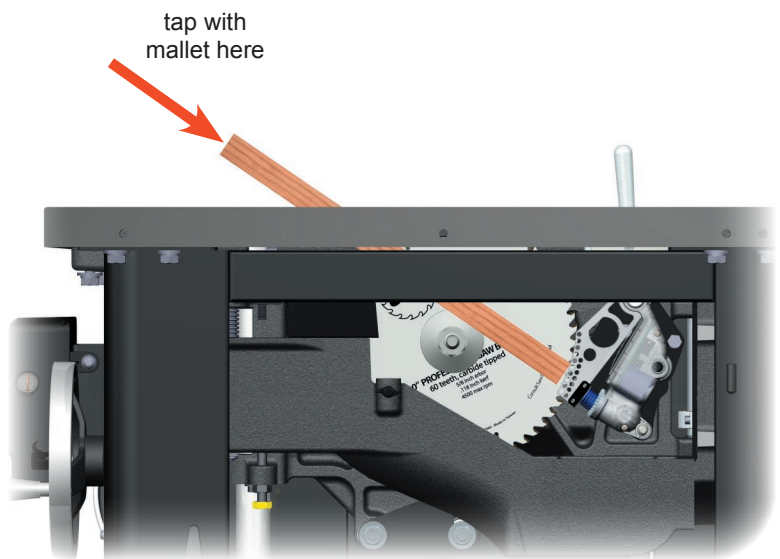

Fig. 42

Using Your Saw

Installing a Brake Cartridge: To install a brake cartridge, the above process is reversed. Align the mounting holes in the cartridge with the pivot pin and positioning pin in the saw. Press the cartridge to the left and onto the pins until it rests against the cartridge mounting bracket. The cartridge will automatically align with the computer cable mounted in the saw.

If you adjusted the brake positioning bolt to release the spring pressure during removal of the brake cartridge, you will need to readjust the bolt before installing the cartridge key. The cartridge key will not fully install into the cartridge when the cartridge mounting bracket is moved away from the blade. This prevents the saw from being used when the brake is too far from the blade.

To adjust the brake positioning bolt, use the included 8 mm hex L-wrench to turn the bolt clockwise until the cartridge key can be fully installed. It is not necessary to adjust the positioning bolt precisely at this time since you will make final adjustments to the brake position once the blade or dado set is installed.

Next, align the cartridge key with the hole in the cartridge housing. The key shaft has a ridge that must be aligned with a recess in the key hole in the housing. As a result, the key can only be inserted into the hole when the red handle is pointing toward the brake pawl. Press the cartridge key fully into the cartridge and rotate the key 90° counter-clockwise to lock the cartridge in place. The key will not rotate unless it is fully seated against the side of the cartridge housing and the cartridge housing is pressed against the cartridge mounting bracket.

Once the key is rotated to its locked position, it cannot be removed and the cartridge will be locked in place. Rotating the key to the locked position also actuates a switch inside the cartridge that signals to the safety system that the cartridge is correctly installed and locked in place. The system will not allow the saw to be started if the switch is not actuated. If you attempt to turn on the saw when the key is not in the locked position, the LED's on the Switch Box will flash an error code as described on page 30.

To complete the installation, the brake cartridge must be correctly positioned relative to the blade or dado set. Once the brake cartridge is installed, rotate the spreader/riving knife clamping handle fully counter-clockwise to lock the spreader or riving knife in place. Next, install the blade or dado set as described on page 18, and adjust the brake position as described on page 19. Rotate the blade by hand at least 1 complete revolution to ensure that the blade does not contact the brake.

If you changed the brake cartridge from the side of the saw reinstall the dust shroud door and close the motor cover. If you changed the brake cartridge through the table opening, make sure the dust shroud door is closed. Finally, reinstall the table insert as described on page 23.

WARNING! Always check, and if necessary, adjust the position of the brake after changing the brake cartridge or the blade. An improperly positioned brake could increase the time required to stop the blade in the event of accidental contact, or cause the brake to actuate unexpectedly if the blade comes into contact with the brake.

What to do if the SawStop Safety System Activates

When the SawStop Safety System is activated, the brake pawl will be pushed into the blade to stop its rotation and the arbor block will retract to lower the blade below the table. Both of these actions will occur within just a few milliseconds. In addition, the safety system will turn off the motor, and display the “Replace Cartridge” system status code on the LED’s on the switch box (see page 30).

Once the safety brake is activated, you will need to carry out the 2 steps described below to reset the safety system and the saw before continuing to use the saw:

1. **Reset the Retraction of the Arbor Block:** during normal use, the front of the arbor block is held in place by a spring-loaded support mechanism. When the brake is activated, the angular momentum of the spinning blade is transferred to the arbor block, causing it to drop out of the support mechanism.

To reset the arbor block into the support mechanism, turn the elevation hand wheel counter-clockwise until the lower elevation limit stop is reached. The arbor block will automatically engage the support mechanism. Now turn the elevation hand wheel clockwise to raise the arbor block and blade.

2. **Replace the Brake Cartridge:** the SawStop brake cartridge must be replaced in the event the brake is activated. In addition to the brake pawl, components inside the sealed housing are expended when the brake is activated. Therefore, the brake cartridge cannot be reused after the brake is activated and it may be discarded or returned to SawStop.

Obtain another brake cartridge that has not been activated and follow the instructions on page 41, to change the brake cartridge.

WARNING! *always make sure that both the Disconnect Switch and the Main Power Switch are in the OFF position before replacing the brake cartridge on your saw.*

3. **Replace the Blade:** when the brake is activated the aluminum brake pawl will pivot into the teeth of the saw blade with a large amount of force and speed. This usually causes the brake pawl to lock up on the blade. If you remove the brake pawl from the blade, one or more of the carbide teeth on the blade will usually be pulled off. Therefore it is almost always necessary to replace the blade after the safety system has been activated.

Once the retraction of the arbor block has been reset and the brake cartridge and blade have been replaced, the saw is ready for operation.

Making Adjustments to Your Saw

Your SawStop saw has been factory adjusted to rigid specifications to provide the highest quality performance and results. Additional adjustment or alignment should not be necessary. Nevertheless, your SawStop cabinet saw has been designed to allow a wide range of adjustments and alignments to achieve the ultimate in precision. Before changing the alignment of any portion of the saw, make sure you read and understand the entire alignment procedure.

WARNING! always make sure that both the Disconnect Switch and the Main Power Switch are in the OFF position before making any adjustments to your saw.

1. Aligning the Blade Elevation Assembly:

The blade elevation assembly controls the motion of the blade as it is raised and lowered. Aligning the blade elevation assembly ensures that there is minimal lateral movement of the blade as it is raised and lowered. Although all table saws suffer from some lateral blade movement due to tolerance stack-ups in the machining, no other major cabinet saw allows you any adjustment to minimize this problem.

The SawStop cabinet saw uses a vertical slide elevation design for ultra smooth operation and rigidity. As shown in Fig. 43, the blade and arbor block are mounted on a large cast iron base called the elevation plate. The elevation plate slides up and down on two shafts that are connected to the front and rear trunnions. This blade elevation assembly is aligned by adjusting the angle of the rear shaft so that it is parallel with the front shaft. When the front and rear shafts are parallel, the blade will have minimum lateral movement as it is raised and lowered.

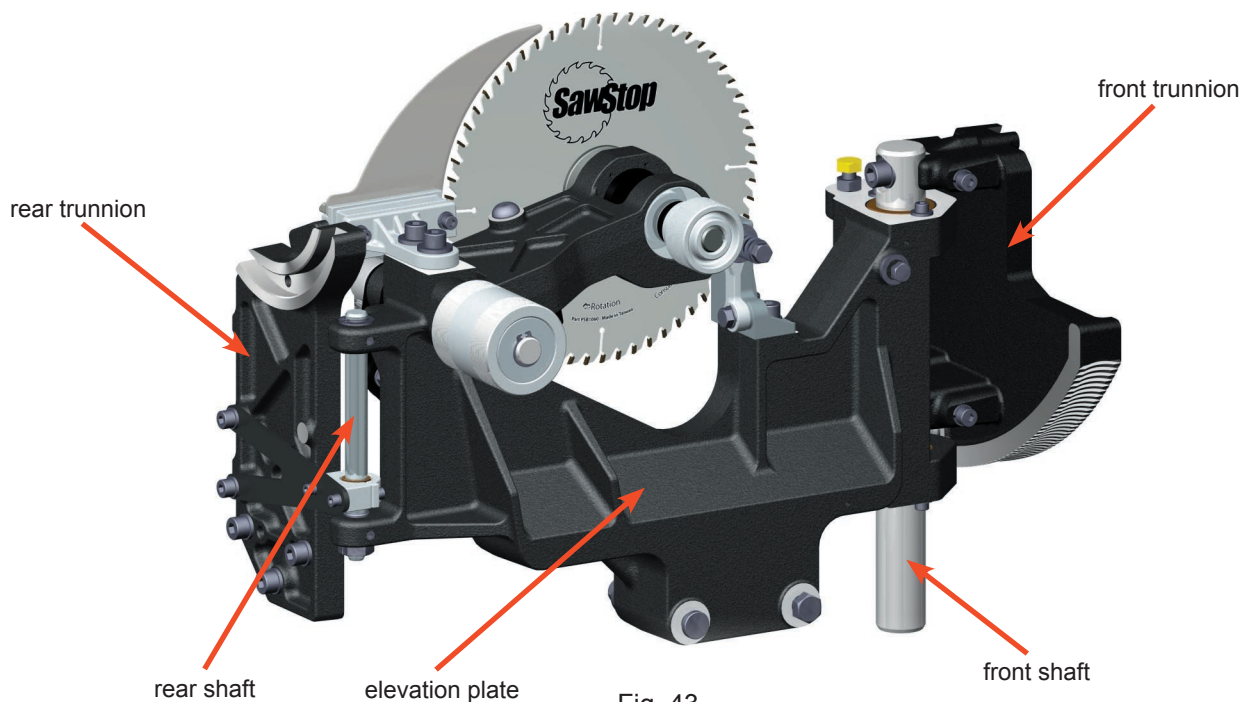

Fig. 43

Making Adjustments to Your Saw

To align the blade elevation assembly, you will need a dial test indicator with a resolution and accuracy of at least 0.0005 inches, and a mount for the indicator. It is not necessary to align the miter slots in the table to the blade before aligning the blade elevation assembly.

Begin by removing the insert and installing a clean, high-quality blade or precision blank onto the arbor as described on page 18. The blade should be flat and parallel to within 0.001 inch or less, and should not be coated with paint or similar materials that may affect the measurement. Attempting to align the blade elevation assembly using a blade that is not very flat will cause similar inaccuracy in the alignment.

Next, set the tilt angle to 0 degrees and lower the blade below the table. When setting the tilt angle and blade elevation, be sure to back the hand wheels off slightly after reaching the limit stops. As with all table saws, pulling the hand wheels tight against the limit stops can cause a slight twisting of the trunnion assembly and lead to inaccurate alignment measurements.

This procedure requires two measurements. For the first measurement, position the dial test indicator near the right side of the blade. The indicator measurement arm should rest against the blade approximately 3 inches in front of the center of the arbor and about 1/2 inch below the upper edge of the blade (see Fig. 44). Depending on the geometry of your dial test indicator, it may be necessary to position the indicator below the table.

Once the dial test indicator is in position, zero the indicator and raise the blade slowly and smoothly to approximately 3 inches above the table. Note the dial reading as the blade rises.

If the dial indicator moves positive and then negative (or vice versa) a substantial amount, or if there is a sudden change in the reading rather than a gradual change, this indicates a non-flat area of the blade. If this happens, try rotating the blade 1/4 turn and retesting. Repeat this process until you get a reading that is not significantly affected by blade flatness. If you cannot get a good reading, try a different blade.

If there is a gradual and continuous change in the dial reading of over 0.002 inch in either the positive or negative direction, rotate the blade 1/2 turn.

Lower the blade below the table and reset the indicator to zero. Raise the blade again while noting the dial reading. If there is similar change but in the opposite direction, this indicates that the left and right surfaces of the blade are not parallel. Rotate the blade 1/4 turn and repeat the process from the beginning. If you cannot get consistent readings, try a different blade.

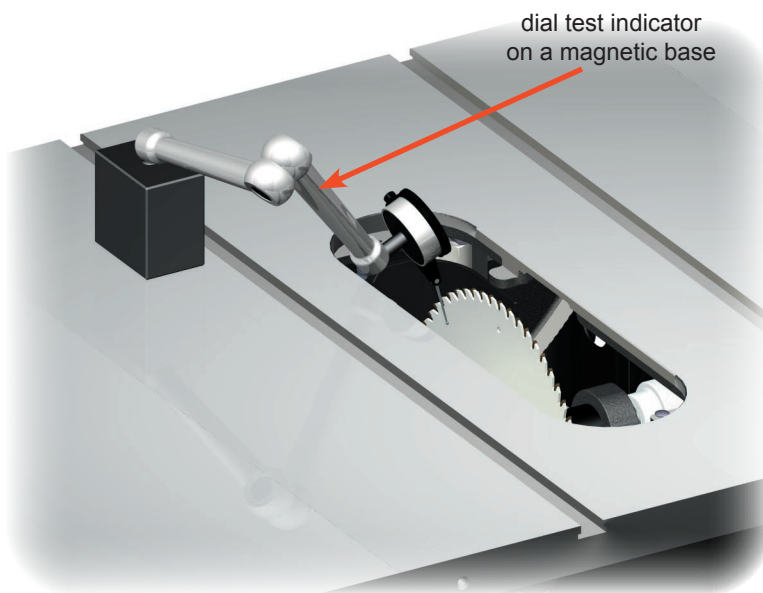

Fig. 44

Making Adjustments to Your Saw

If the dial indicator reads a relatively consistent difference between the lateral blade position at zero elevation and 3 inches elevation, take the average of the two readings and write it down. Make sure you note whether the average is positive or negative.

For example:

if the reading at 0" elevation was +0.001 inch,

and the reading at 3" elevation was -0.002 inch;

the difference would be $+0.001 - (-0.002) = 0.003$ inch.

For the second measurement, reposition the dial indicator arm so that it is approximately 3 inches behind the center of the arbor, and about 1/2 inch below the upper edge of the blade when the blade is below the table (see Fig. 45). Repeat the measurement procedure above. Take the average of the two consistent readings and write it down, making sure to note whether it is positive or negative.

Now subtract the lower reading from the higher reading. This difference is proportional to the amount of non-parallelism between the front and rear shafts. A difference of 0.002 inch or less is within the margin of error for this measurement and, therefore, no further alignment is needed. If the difference is greater than 0.002 inch, you can adjust the alignment of the rear shaft relative to the front shaft to reduce the error.

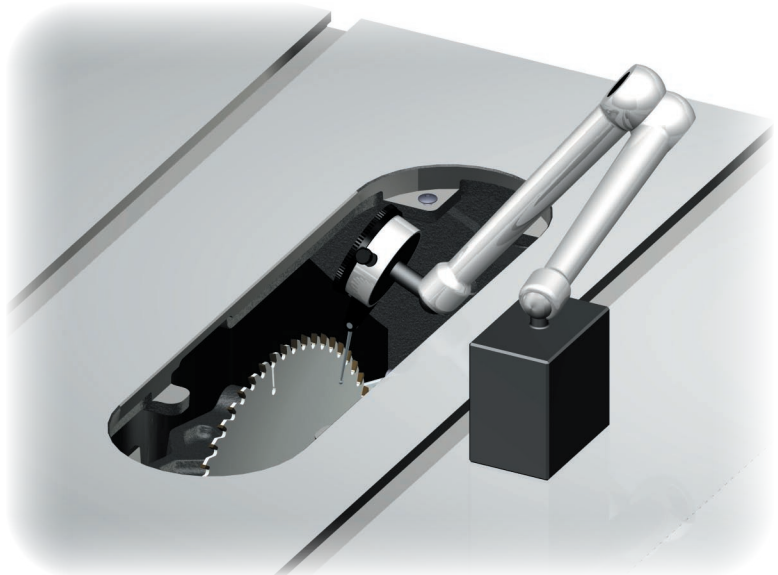

Fig. 45

Making Adjustments to Your Saw

The angle of the rear shaft is set by the eccentric bushing at the bottom of the shaft (see Fig. 46). The eccentric bushing is locked in place by a 4 mm set screw in the elevation plate, and a 2.5 mm set screw in the side of the bushing keeps the rear shaft tight in the bushing.

To adjust the shaft angle, make sure the blade is still about 3 inches above the table and the dial indicator is still reading the second measurement (if not, repeat the second measurement as described above). Next, loosen the 4 mm set screw on the elevation plate and the 2.5 mm set screw on the eccentric bushing. You can access the set screws by opening the access door on the left side of the cabinet.

Once the set screws are loosened, the eccentric bushing should be free to turn. Using a 22 mm open-end wrench or an adjustable wrench, turn the bushing in either direction while watching the dial test indicator reading. Turn the bushing until the reading is the same as the first measurement you took (i.e., with the dial indicator arm positioned in front of the arbor).

Now lower the blade below the table and reset the indicator to zero. Raise the blade to about 3 inches above the table and check the indicator readout. This is the new second measurement.

If necessary, adjust the bushing again until the readout matches the first measurement. Repeat this process until the second measurement is within 0.002 inch of the first measurement. Once the angle of the rear shaft has been set, tighten the set screw in the elevation plate and the set screw in the eccentric bushing. Make sure the readout does not change when the set screws are tightened.

To confirm that the shafts are now parallel, you can repeat the procedure described above from the beginning. Occasionally the alignment procedure will make a small change to the first measurement. If necessary, realign the rear shaft until the difference between the first and second measurements is negligible.

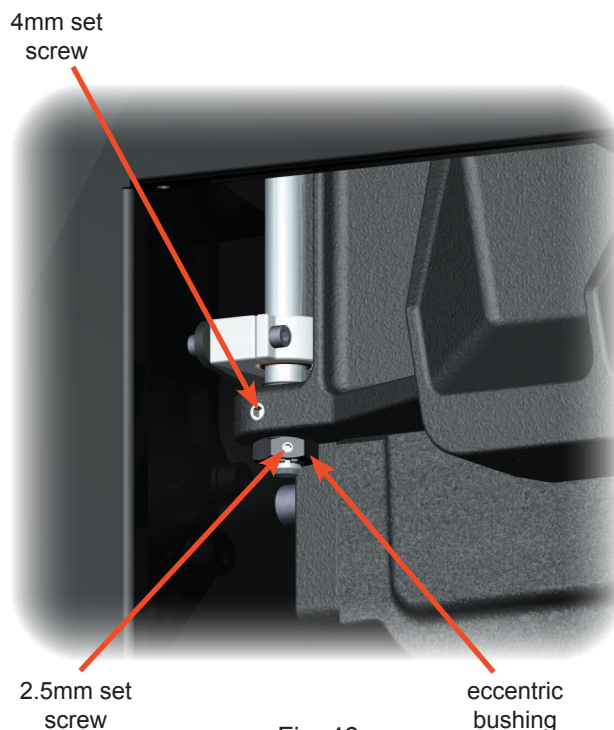

Fig. 46

Making Adjustments to Your Saw

2. Aligning the Table:

For accurate cuts with the miter gauge, the miter slots in the table should be parallel to the blade. This also helps with rip cuts since the rip fence is often aligned to the miter slots. Two procedures for aligning the table are described below. The preferred procedure is described first and provides an accuracy of about ± 0.002 inch. An alternative procedure is also described which provides an accuracy of about ± 0.010 inch.

Preferred Table Alignment Procedure:

To align the table precisely, you will need a dial test indicator with a resolution and accuracy of at least 0.0005 inches, and a mount for the indicator that will slide smoothly in the miter slots. The mount should slide on the table on either smooth plastic glide plates or on ball bearing rollers. The mount should also include a lower rail or similar structure that fits relatively tightly in the miter slot, but not so tight as to prevent the mount from sliding. A sample mount is shown in Fig. 47.

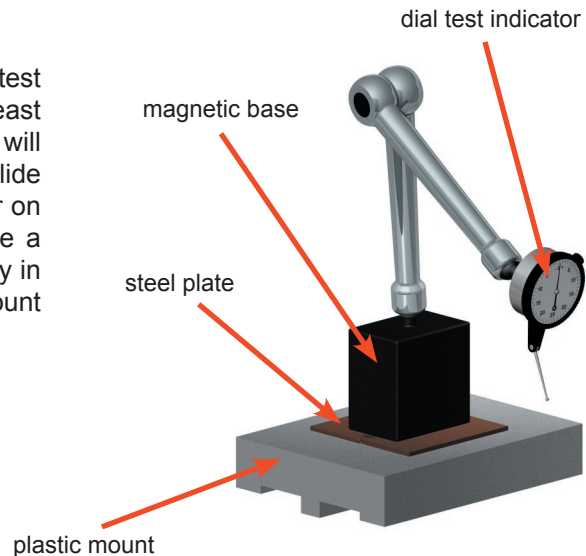

Fig. 47

Begin by removing the insert as described on page 23, and installing a clean, high-quality blade or precision blank onto the arbor as described on page 18. The blade should be flat and parallel to within 0.001 inch or less, and should not be coated with paint or similar materials that may affect the measurement. Attempting to align the table using a blade with a lower flatness will cause similar inaccuracy in the alignment.

Next, set the tilt angle to 0 degrees, making sure to back the tilt hand wheel off slightly to release the pressure between the front trunnion and the tilt limit stop. Raise the blade elevation to approximately 3 inches above the table.

Position the dial test indicator so that the measurement arm rests against the right side of the blade and about 1/4 inch above the center of the arbor flange. Slide the mount forward until the measurement arm is about 1/2 inch inside the front edge of the blade. See Fig. 48.

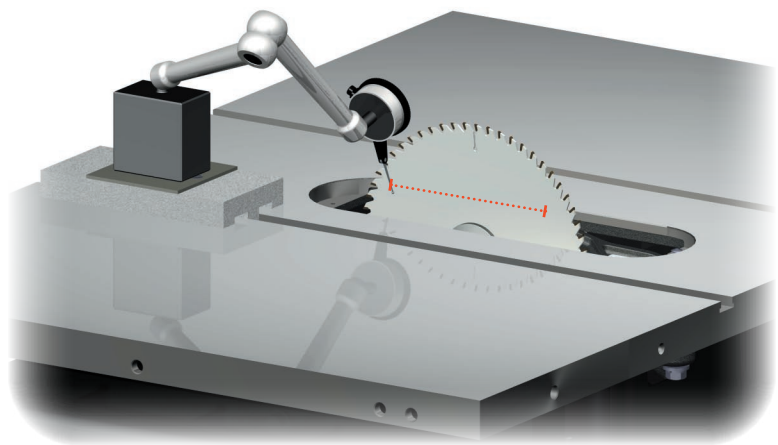

Fig. 48

Making Adjustments to Your Saw

Set the dial indicator to zero. Slide the dial test indicator mount smoothly toward the back of the saw until the measurement arm is about 1/2 inch inside the rear edge of the blade. Note the reading of the dial indicator as the mount moves across the blade.

If the dial indicator moves positive and then negative (or vice versa) a substantial amount, or if there is a sudden change in the reading rather than a gradual change, this indicates a non-flat area of the blade. If this happens, try rotating the blade 1/4 turn and retesting. Repeat this process until you get a reading that is not significantly affected by blade flatness. If you cannot get a good reading, try a different blade.

If there is a gradual and continuous change in the dial reading of over 0.002 inch in either the positive or negative direction, rotate the blade 1/4 turn. Slide the dial indicator mount back toward the front of the blade and reset the indicator to zero. Now slide the mount toward the back of the saw again while noting the dial reading. If there is similar change but in the opposite direction, this indicates that the left and right surfaces of the blade are not parallel. Rotate the blade 1/4 turn and repeat the process from the beginning. If you cannot get consistent readings, try a different blade.

If the dial indicator reads a relatively consistent difference between the front and rear of the blade, take the average of the readings. A measurement of 0.002 inch or less indicates that the table is aligned within the margin of error for this measurement and no further alignment is necessary. For measurements larger than 0.002 inch, you can adjust the position of the table to increase the parallelism between the blade and the miter slot.

To begin, loosen the 4 mounting bolts (see Fig. 49) that attach the table to the front and rear trunnion brackets, using a 17 mm wrench or an adjustable wrench. Slide the dial indicator to the front of the blade and set the readout to zero. Slide the dial indicator mount to the rear of the blade. The dial indicator should now be reading close to the average measurement.

The table alignment is set by a pivot pin at the front of the table, and positioning screws at the rear of the table on both the left and right sides. If the measurement is positive, loosen the left positioning screw and tighten the right positioning screw. If the measurement is negative, loosen the right positioning screw and tighten the left positioning screw.

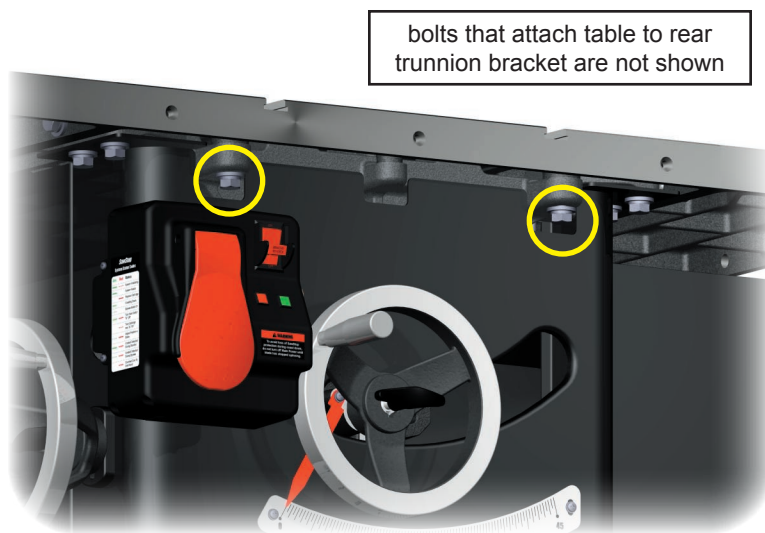

Fig. 49

You should see the readout on the dial indicator change as you adjust the positioning screws. Adjust the screws until the readout is the same, but in the reverse direction. For example, if the initial reading was +0.006 inch, adjust the positioning screw until the reading is -0.006 inch.

Making Adjustments to Your Saw

Now slide the dial indicator mount back to the front of the blade and re-zero the readout. Slide the indicator mount smoothly forward until the indicator measurement arm is about 1/2 inch inside the rear edge of the blade. The new measurement should be much closer to 0.000 inch.

If the new measurement is not zero, repeat the above process until the parallelism between the blade and the miter slot is satisfactory. Finally, tighten the four table mounting bolts to secure the table to the front and rear trunnion brackets. For best results, sequentially tighten each bolt a little at a time until all are tight. Watch the dial indicator while tightening, and if one bolt causes a significant change, tighten the other bolts first.

Alternate Table Alignment Procedure:

For this procedure you will need a set of calipers or a combination square. Begin by removing the table insert and installing a blade or reference plate as described in the Preferred Table Alignment Procedure. Set the tilt angle to 0° and raise the blade elevation to approximately 3 inches above the table.

Select a point on the edge of the blade that is between two consecutive teeth and place a mark near that point. Rotate the blade until that mark is just above the table and toward the front of the saw. If you are using calipers, measure the distance between the left edge of the right-hand miter slot and the left side of the blade. (*Make sure to measure to the flat plate of the blade rather than the tooth*) If you are using a combination square, set the end of the ruler flat against the right side of the blade, and position the base to be flush against the left side of the right-hand miter slot. See Fig. 50. Write the measurement down.

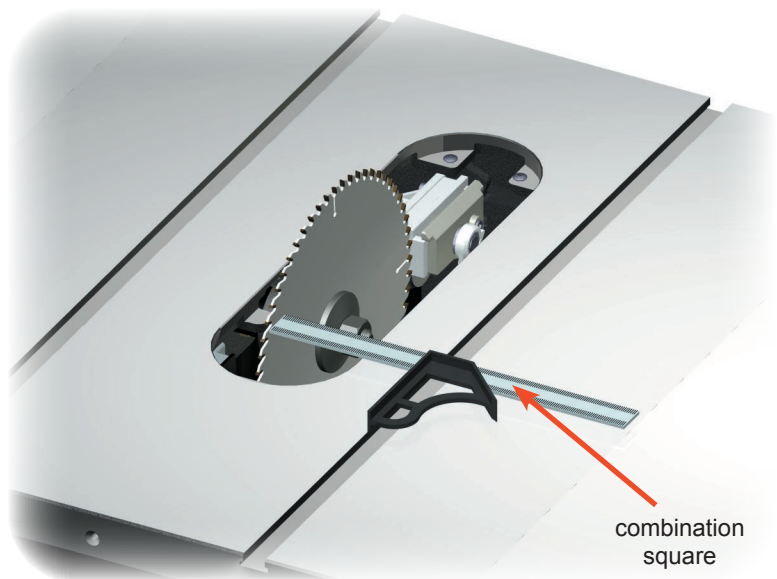

Fig. 50

Making Adjustments to Your Saw

Now rotate the blade until the point you marked is just above the table but toward the back of the saw. Repeat the measurements above (see Fig. 51). If necessary, loosen the table mounting bolts and adjust the position of the table as described in the Preferred Table Alignment Procedure. Repeat the above measurements and table alignment until you are satisfied with the parallelism between the blade and the miter slot. Finally, tighten the table mounting bolts.



Fig. 51

3. Aligning the Blade to the Tilt Axis:

When making bevel cuts, the blade is tilted on a axis that runs along the surface of the table between the front and rear trunnion brackets. See Fig. 52. If the blade is not parallel to this axis, the blade will move out of parallel with the miter slots when it is tilted away from 0° (this assumes the table has been aligned to be parallel to the blade at 0° tilt angle). The SawStop cabinet saw is the only major cabinet saw that allows you to fine tune the parallelism of the blade and the tilt axis.

The geometry involved in this alignment procedure is tricky. That is because there is no way to easily measure the parallelism between the blade and the tilt axis. Instead, you must measure the alignment between the blade and the table at both 0° tilt and 45° degrees tilt. The difference in those measurements is proportional to the non-parallelism between the blade and the tilt axis. To ensure accurate alignment, follow the procedure described below exactly.

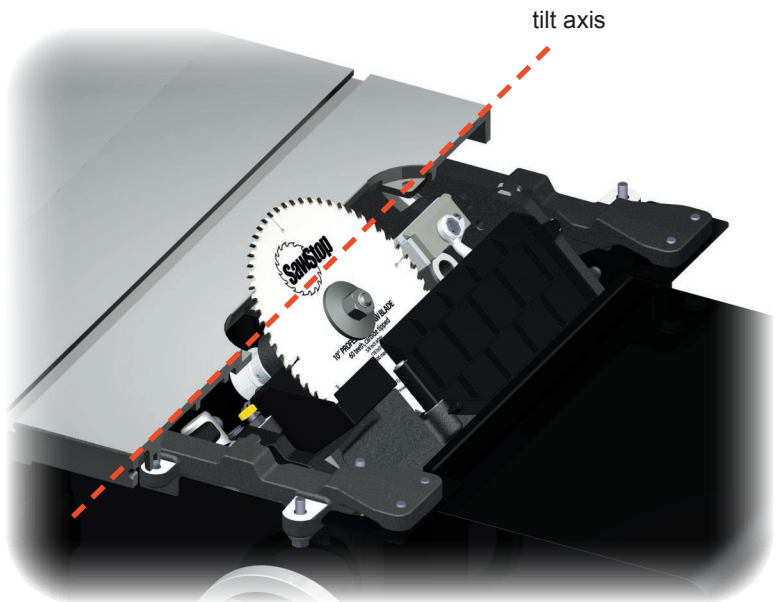

Fig. 52

Making Adjustments to Your Saw

To align the blade to the tilt axis, you will need a dial test indicator with a resolution and accuracy of at least 0.0005 inches, and a mount for the indicator that will slide smoothly in the miter slots. An example of a suitable mount is shown in Fig. 47. You will also need a 6 mm hex L-wrench (a “stubby” hex L-wrench works best).

NOTICE! *this alignment procedure is not intuitive. Make sure you read this entire procedure before beginning and follow each step precisely. Any deviation from this procedure may create a substantial misalignment in your saw.*

First, align the table as described on page 50, using the precision alignment procedure. Make sure the non-parallelism between the miter slot and the blade is as close to zero as possible.

Next, move the dial indicator measurement arm off the blade and tilt the blade to approximately 45°. Make sure not to tighten the tilt hand wheel against the 45° limit stop. Now reposition the dial indicator measurement arm against the right side of the blade and about 1/4 inch directly above the arbor flange. Slide the dial indicator mount toward the front of the saw until the measurement arm is about 1/2 inch inside the front edge of the blade. See Fig. 53. Set the dial indicator readout to zero.

Slide the dial test indicator mount smoothly toward the back of the saw until the measurement arm is about 1/2 inch inside the rear edge of the blade. Note the reading of the dial indicator as the mount moves across the blade. Write down the final number, including whether it is positive or negative. This number is proportional to the non-parallelism between the blade and the tilt axis.

A measurement of 0.002 inch or less indicates that the blade is parallel to the tilt axis within the margin of error for this measurement and no further alignment is necessary. For measurements larger than 0.002 inch, you can adjust the angle of the blade to increase the parallelism between the blade and the tilt axis. The adjustment must be made at a 0° tilt angle.

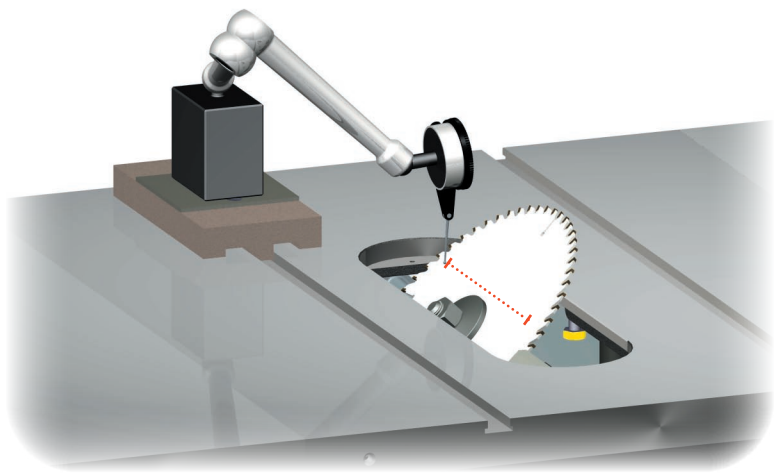

Fig. 53

To do this, set the tilt angle back to 0° and reposition the dial test indicator as described above. When you slide the dial indicator mount across the blade, you should see little or no change in the indicator readout. Now, slide the dial indicator toward the rear of the saw until the measurement arm is about 1/2 inch inside the rear edge of the blade. Set the readout to zero.

Making Adjustments to Your Saw

The angle of the blade relative to the tilt axis is controlled by a v-bracket that connects the rear elevation shaft to the rear trunnion (see Fig. 54). The v-bracket is connected to the rear trunnion by two 6 mm bolts. The holes in the v-bracket are oversized to allow the position of the v-bracket to be adjusted relative to the rear trunnion.

Using the 6 mm hex wrench, loosen the bolts just enough to allow the v-bracket to move when force is applied. You can access the bolts by opening the motor cover.

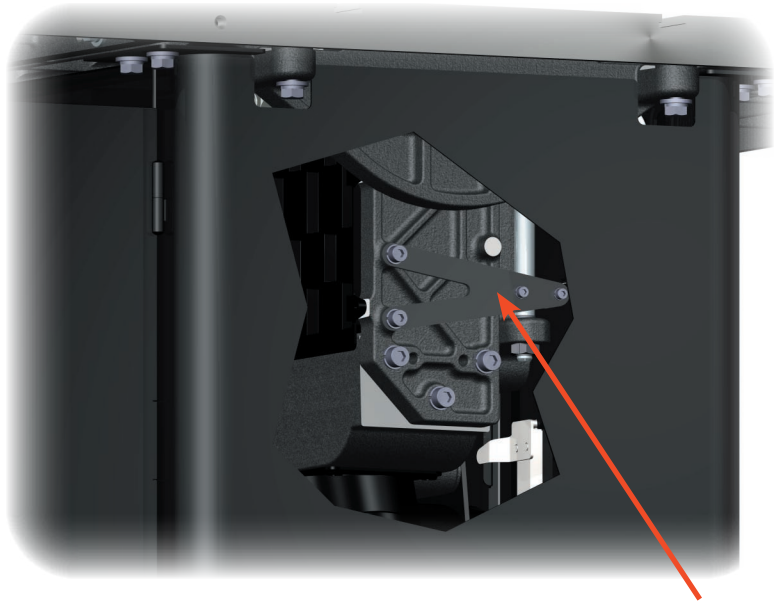

Fig. 54

v-bracket

To align the blade to the tilt axis, you need to adjust the position of the v-bracket until the misalignment between the blade and the miter slot at a 0° tilt angle is -2.5 times the misalignment measured at a 45° tilt angle.

For example:

if the misalignment at 45° was +0.006 inch,

then the misalignment at 0° should be adjusted to $(-2.5) \times (0.006) = -0.015$ inch

Making Adjustments to Your Saw

To create a negative misalignment, use a block of wood and a mallet to tap the edges of the v-bracket (see Fig. 55). To create a positive misalignment, use a block of wood and a mallet to tap the left side of the elevation plate (see Fig. 56).

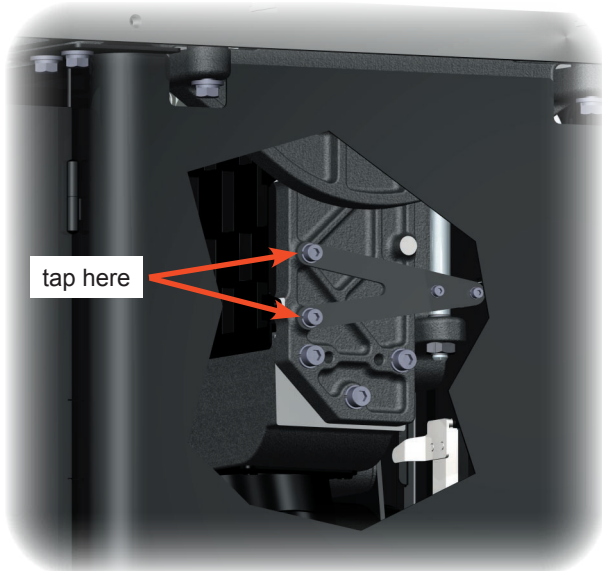

Fig. 55

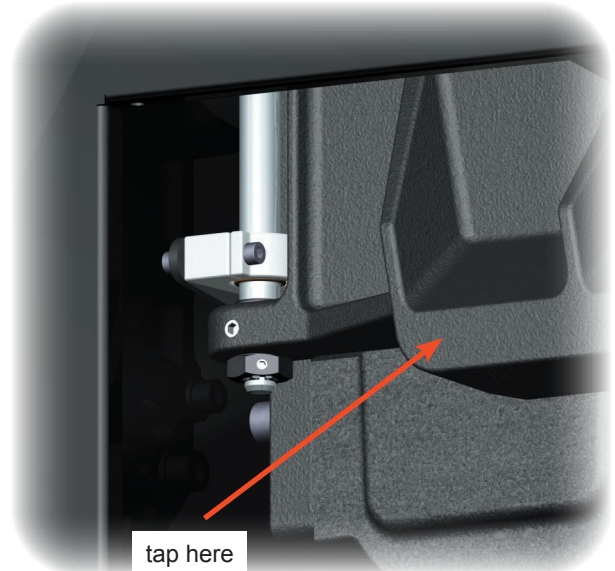

Fig. 56

Reposition the dial test indicator toward the front of the saw with the measurement arm about 1/2 inch inside the front edge of the blade. Set the dial readout to zero. Slide the dial indicator mount toward the back of the saw until the measurement arm is about 1/2 inch inside the rear edge of the blade. Note the readout.

If the readout is -2.5 times the misalignment measured at 45°, the v-bracket should be correctly positioned. Otherwise, repeat the above process of adjusting the position of the v-bracket, and then measuring the misalignment until the misalignment is -2.5 times the misalignment measured at 45°.

Once the v-bracket is positioned correctly, tighten the bolts that attach the v-bracket to the rear trunnion. The blade should now be parallel to the tilt axis.

Since the alignment of the blade has been changed, the table must now be realigned. Align the table as described on page 50, using the precision alignment procedure. Once the table has been realigned, you can check the parallelism of the blade to the tilt axis by tilting the blade to about 45° and measuring the alignment between the blade and the miter slot. If the misalignment of the blade and the miter slot is less than 0.002 inch at both 0° and 45°, then the blade is parallel to the tilt axis.

Making Adjustments to Your Saw

4. Adjusting the Elevation Limit Stops:

The upper elevation limit stop prevents the arbor block and belts from hitting the underside of the table. The lower elevation limit stop prevents the arbor block or blade from hitting the lower trunnion assembly. The elevation limit stops must be adjusted correctly to ensure proper operation of the saw.

Upper Elevation Limit Stop

To check the position of the upper elevation limit stop, install a 10 inch saw blade on the arbor (see page 18), and turn the elevation hand wheel clockwise until the limit stop is reached. Using a combination square or similar tool, measure the distance from the top of the table to the tip of the highest tooth on the blade. The maximum height of the blade above the table should be 3 1/8 inches. If the blade is 3 3/16 inches or higher above the table, the upper elevation limit stop should be adjusted downward. If the blade is less than 3 1/8 inches above the table, you can adjust the limit stop upward to 3 1/8 inches. Alternatively, you can adjust the limit stop so that the maximum blade height is lower than 3 1/8 inches.

The upper elevation limit stop is set by the bolt mounted in the lower front portion of the elevation plate (see Fig. 57). You can access the upper limit bolt by opening the motor cover. The head of the bolt is painted yellow for easy identification. To adjust the position of the upper limit bolt, first loosen the locking nut and back it off several turns. If you plan to adjust the limit stop upward, turn the bolt counter-clockwise several turns.

Next, set the blade elevation to the correct maximum height. Turn the upper limit bolt clockwise until it is tight. Finally, turn the locking nut clockwise until it is tight. The upper elevation limit stop has now been set.

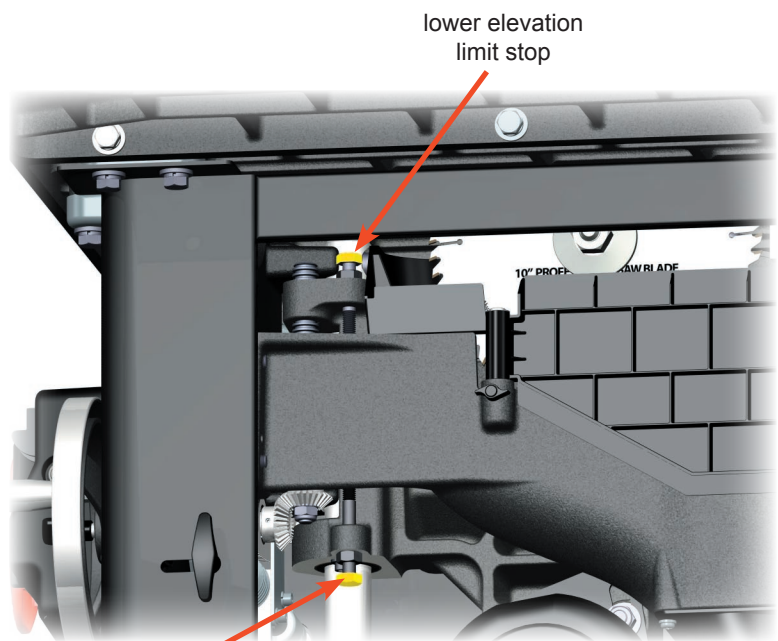

Fig. 57

upper elevation
limit stop

Making Adjustments to Your Saw

Lower Elevation Limit Stop

To check the position of the lower elevation limit stop, remove the blade from the arbor and open the motor cover. While watching the arbor block through the motor cover opening, turn the elevation hand wheel counter-clockwise until the bottom of the arbor block just touches the rubber bumper mounted on the trunnion brace (see Fig. 58).

The purpose of the bumper is to absorb the energy of the arbor block when the arbor block retracts below the table upon activation of the safety system. As shown in Fig. 58, the lower elevation limit stop should be adjusted so that the arbor block compresses the bumper about 1/4 inch at the lowest elevation. This should also ensure that a 10 inch blade is at least 1/8 inch below the top of the table.

Lower the blade elevation until the lower limit stop is engaged. If the bumper is compressed about 1/4 inch, no further adjustment is necessary.

The lower elevation limit stop is set by the bolt mounted in the upper front portion of the elevation plate (see Fig. 57). The head of the bolt is painted yellow for easy identification. To adjust the position of the lower limit bolt, first loosen the locking nut and back it off several turns. If you plan to adjust the limit stop downward, turn the bolt counter-wise several turns.

Next, set the blade elevation to the correct minimum height. Turn the lower limit bolt clockwise until it is tight. Finally, turn the locking nut clockwise until it is tight. The lower elevation limit stop has now been set.

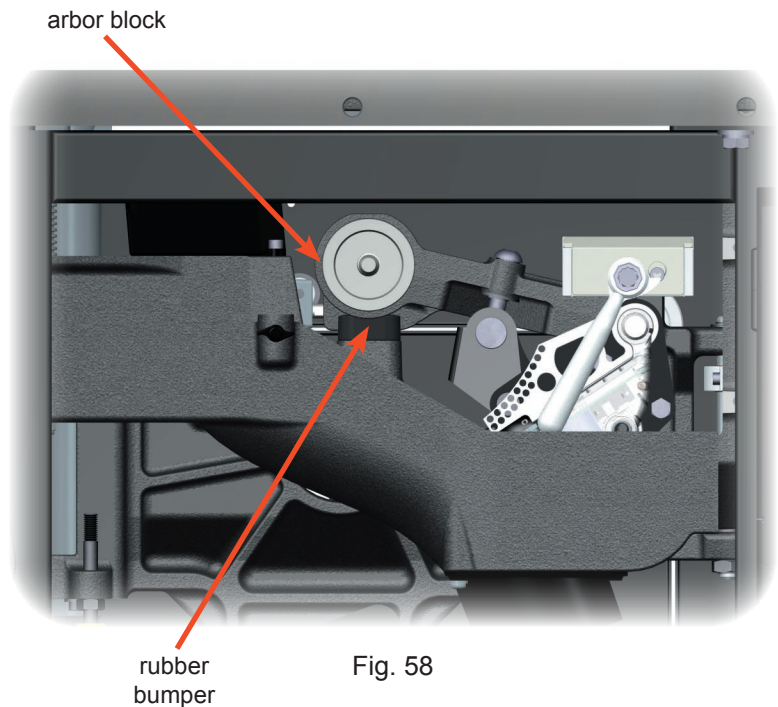

Making Adjustments to Your Saw

5. Adjusting the Tilt Limit Stops and Tilt Angle Indicator:

The tilt limit stops allow you to easily and quickly set the bevel angle to 0° and 45°. However, when making precision cuts, it is always best to check the angle of the blade with a combination square or similar tool.

0 Degree Tilt Limit Stop

To check the position of the 0° limit stop, install a 10 inch saw blade on the arbor (see page 18). Raise the blade to its full elevation, and turn the tilt hand wheel counter-clockwise until the limit stop is reached. Using a square, check to see that the blade is at a 90° angle to the table (see Fig. 59).

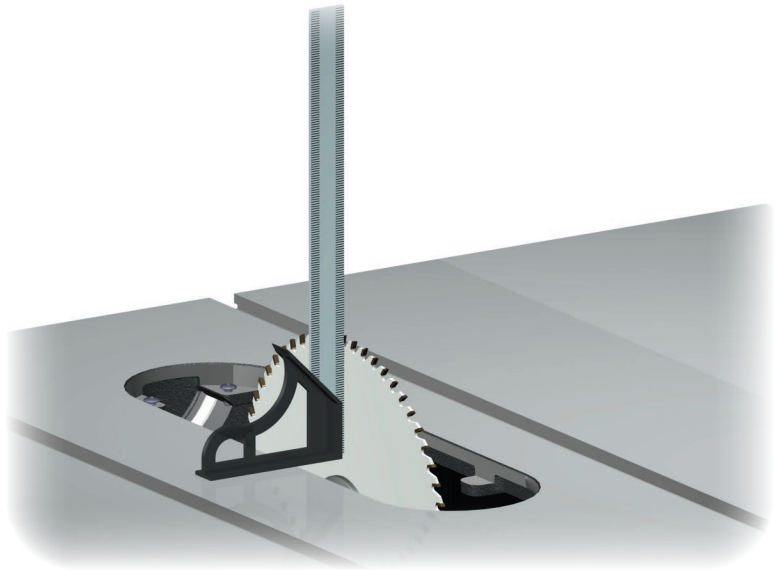

Fig. 59

The 0° tilt limit stop is set by the bolt mounted in the upper left portion of the front trunnion bracket (see Fig. 60). You can access the bolt by opening the belt access door on the left side of the cabinet. The head of the bolt is painted yellow for easy identification. To adjust the position of the 0° limit stop, first loosen the locking nut and back it off several turns. If you plan to adjust the limit stop backward, turn the bolt counter-wise several turns.

Next, adjust the tilt angle until the blade is at 90° to the table. Turn the 0° limit bolt clockwise until it is tight. Finally, turn the locking nut clockwise until it is tight. The 0° limit stop has now been set.

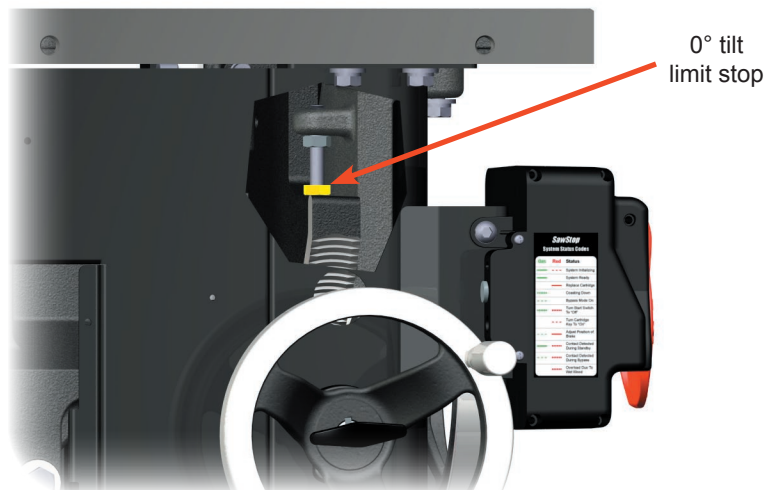

Fig. 60

Making Adjustments to Your Saw

Tilt Angle Indicator

The tilt angle indicator is located at the front of the cabinet, just behind the elevation hand wheel (see Fig. 61). The indicator shows the current angle of the blade relative to vertical (i.e., perpendicular to the table top).

Once the 0° limit stop is correctly set, turn the tilt hand wheel counter-clockwise until the limit stop is reached. Check the reading of the tilt angle indicator. If necessary adjust the indicator by loosening the locking screw and rotating the indicator until it reads 0°. Finally, lock the indicator in place by tightening the locking screw.



tilt angle indicator

Fig. 61

locking screw

45 Degree Tilt Limit Stop

To check the position of the 45° limit stop, install a 10 inch saw blade on the arbor (see page 18). Raise the blade to its full elevation, and turn the tilt hand wheel clockwise until the limit stop is reached. Using a square, check to see that the blade is at a 45° angle to the table (see Fig. 62). If you need to adjust the position of the 45° limit stop follow the instructions below.

The 45° tilt limit stop is set by the bolt mounted in the upper right portion of the front trunnion bracket (see Fig. 63 on page 61). You can access the bolt by opening the motor cover. It will also be necessary to decrease the tilt angle to about 30° to access the 45° limit bolt.



Fig. 62

Making Adjustments to Your Saw

The head of the bolt is painted yellow for easy identification. To adjust the position of the 45° limit bolt, first loosen the locking nut and back it off several turns. Next, turn the 45° limit bolt clockwise to increase the angle of the limit stop, or counter-clockwise to decrease the angle of the limit stop.

Now turn the tilt hand wheel clockwise until the limit stop is reached. Recheck the angle of the blade relative to the table. If further adjustment is needed, decrease the tilt angle to about 30° and readjust the 45° limit bolt. Repeat this process until the blade is at 45° to the table when the limit stop is engaged.

Once the 45° limit bolt is properly adjusted, turn the locking nut clockwise until it is tight. The 45° limit stop has now been set.

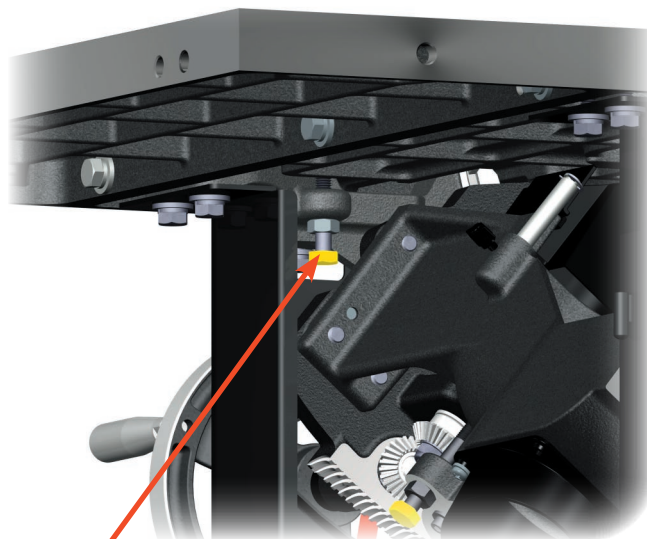

45° tilt limit stop

Fig. 63

6. Adjusting the Table Insert:

The SawStop zero clearance insert has been designed to fit securely within the table opening and just below the table top. The insert is pre-cut at the factory with a 10 inch blade after all alignments to the saw have been completed.

As shown in Fig. 64, the insert includes front and rear leveling screws to set the height of the insert. In addition, positioning screws at the front and right side of the insert prevent it from rattling in the table opening. Finally, a lock-down screw at the front of the insert prevents the insert from rising up unexpectedly. The lock-down screw fits inside an adjustable threaded bushing that prevents the lock-down screw from pulling the front of the insert too low.

To set the height of the insert, first remove the lock-down screw. Next, back off the threaded bushing by turning it counter-clockwise about one full turn using the included 5 mm hex wrench. Then use the included 3 mm hex wrench to adjust the front and rear leveling screws until the insert is just below the surface of the table. The lower end of each leveling screw should rest on the corresponding support ledge on the table.

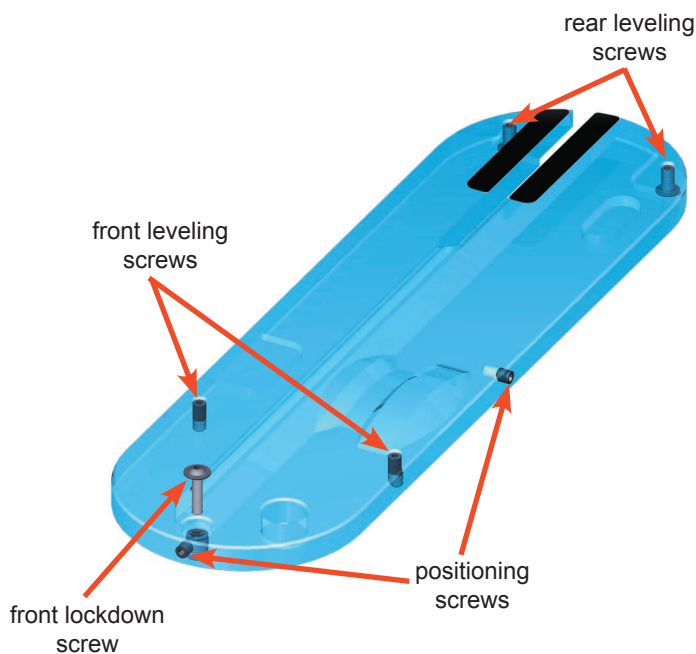

Fig. 64

Making Adjustments to Your Saw

The insert should slide easily into and out of the table opening, but should not be loose in the opening. If the insert is too loose, use the 3 mm hex wrench to turn the side and/or front positioning screw(s) counter-clockwise as needed to reduce the clearance between the insert and the table opening. If the insert is too tight, turn the side and/or front positioning screw(s) clockwise as needed to increase the clearance between the insert and the table opening.

Now turn the threaded bushing clockwise until the lower portion of the bushing touches the support ledge on the table. Make sure not to lower the bushing so much that it raises the front of the insert. Finally, install the locking screw through the bushing to lock the insert in the table opening.

Adjusting the Rear Lock-Down Screws

The rear of the table insert is held down by a pair of lock-down screws mounted in the table at the rear of the table opening. As shown in Fig. 65, the lock-down screw heads fit between the bottom of the insert and the heads of the rear leveling screws.

The height of the lock-down screws should be adjusted to fit close above the leveling screws, while allowing enough clearance to install and remove the table insert without difficulty. The height of the lock-down screws can be adjusted using the included 3 mm hex wrench.

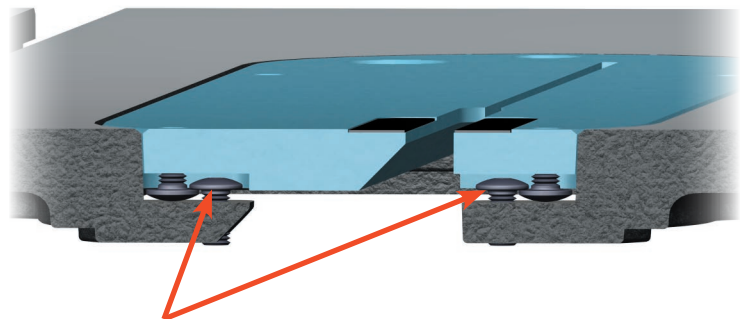

table lockdown screws

Fig. 65

7. Aligning the Riving Knife and Spreader to the Blade:

For safe operation, the spreader and riving knife should be aligned parallel to the blade, and positioned inside the kerf of the blade. The spreader, or alternatively, the riving knife, is held in position by a quick-release clamp (see Fig. 66) mounted under the table and behind the blade. Once the clamp is properly adjusted, the spreader and riving knife will automatically align to the blade when installed in the clamp.

To adjust the clamp, set the tilt angle to 0° and remove the table insert. Make sure the spreader is installed, and lower the blade elevation to zero. Remove the blade and set it aside for a moment.

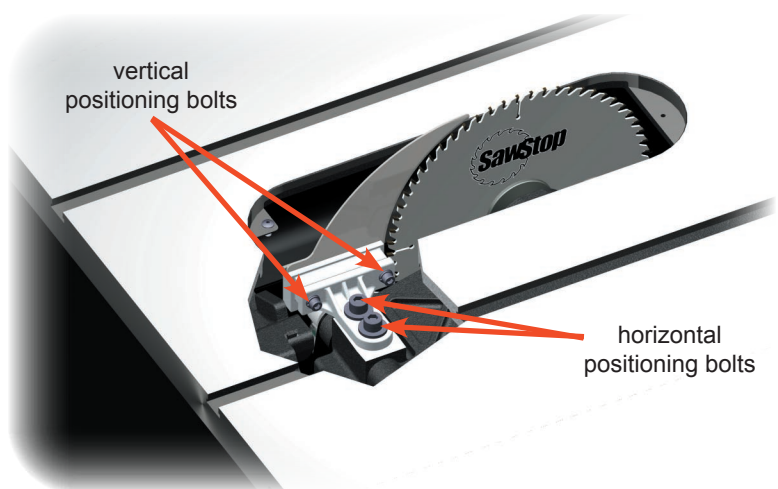

Fig. 66

Making Adjustments to Your Saw

Next, loosen the horizontal positioning bolts using a 8 mm hex L-wrench. Loosen the bolts just enough to allow the clamp mounting bracket to slide along its mounting surface. Reinstall the blade.

Place a straight edge along the right side of the blade, making sure the straight edge runs between the teeth of the blade. Now adjust the position of the clamp until the right side of the spreader is flush and flat against the straight edge. If necessary, pivot the right anti-kickback pawl up out of the way while performing this step.

Note: if you are using a thin-kerf blade (i.e., kerf is 0.080 to 0.094 in.), you may need to place one or more shims between the straight edge and the side of the blade to ensure the spreader is positioned inside the kerf of the blade.

Once the spreader is positioned parallel to the blade, check the distance between the curved, front edge of the spreader and the edge of the blade. There should be a gap of approximately 2 mm between the center-point of the arc on the front of the spreader and the rear edge of the blade (see Fig. 67). If necessary, slide the clamp forward or backward until the spacing between the blade and the spreader is approximately correct.

Remove the blade and set it aside for a moment. Tighten the horizontal positioning bolts. Remove the spreader and install the riving knife.

Next, loosen the vertical positioning bolts using the included 5 mm hex L-wrench. Loosen the bolts just enough to allow the clamp to slide up and down on the clamp mounting bracket. Reinstall the blade.

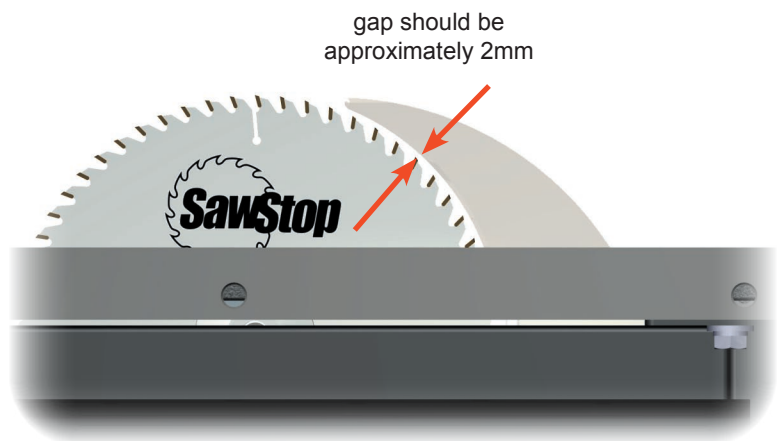

Fig. 67

Making Adjustments to Your Saw

The top of the riving knife should be approximately 1 mm below the top of the blade (see Fig. 68). This allows the riving knife to be used on rabbet cuts and other non-through cuts. In addition, the arc on the front of the riving knife should be concentric with the blade.

Rest a level on the top of the blade and measure the distance from the bottom of the level to the top of the riving knife. If necessary, adjust the position of the clamp up or down to set the height of the riving knife, and rotate the clamp forward or backward until the arc on the riving knife is concentric with the blade.

Once the vertical alignment of the riving knife is correct, tighten the vertical positioning bolts.

In some cases, adjusting the vertical alignment may cause the spacing between the riving knife and the edge of the blade to be incorrect. If this happens, remove the riving knife and the blade. Install the spreader and loosen the horizontal positioning bolts. Now reinstall the blade.

Using the straight edge, reposition the spreader so that it is parallel and flush with the side of the blade, and so the spacing between the edge of the blade and the arc of the spreader is approximately 2 mm. Remove the blade and tighten the horizontal positioning bolts.

Make sure all the positioning bolts are tight. Once the clamp has been properly positioned, further adjustment should not be necessary. Both the spreader and riving knife should be aligned when installed in the clamp.

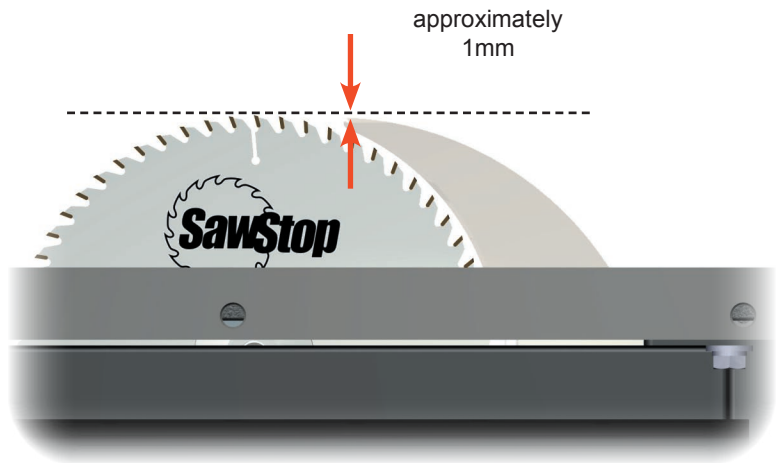

Fig. 68

WARNING! make sure there is at least 1mm spacing between the riving knife and blade at all points. Contact between the blade and either the riving knife or spreader during operation will cause the brake system to be activated.

Making Adjustments to Your Saw

8. Adjusting the Tilt Gearing:

The tilt hand wheel changes the tilt angle of the blade by rotating a worm gear that engages a sector gear on the front trunnion. The worm gear should be fully engaged in the sector gear to eliminate any play in the tilt control mechanism. If the tilt angle does not begin changing as soon as the tilt hand wheel is turned, then it may be necessary to adjust the position of the worm gear. Alternatively, it may be necessary to adjust the position of the worm gear if the tilt hand wheel binds up during rotation.

The worm gear is mounted on the tilt control shaft and supported by the tilt shaft bracket (see Fig. 69). The tilt shaft bracket is mounted on the back of the front trunnion bracket by a pair of 5 mm hex socket-head bolts. To adjust the position of the worm gear, loosen the two mounting bolts using a 5 mm hex L-wrench. Move the worm gear upward to eliminate any play in the tilt mechanism, or move the worm gear downward to prevent binding. Tighten the mounting bolts and test the tilt mechanism to confirm that it is properly adjusted.

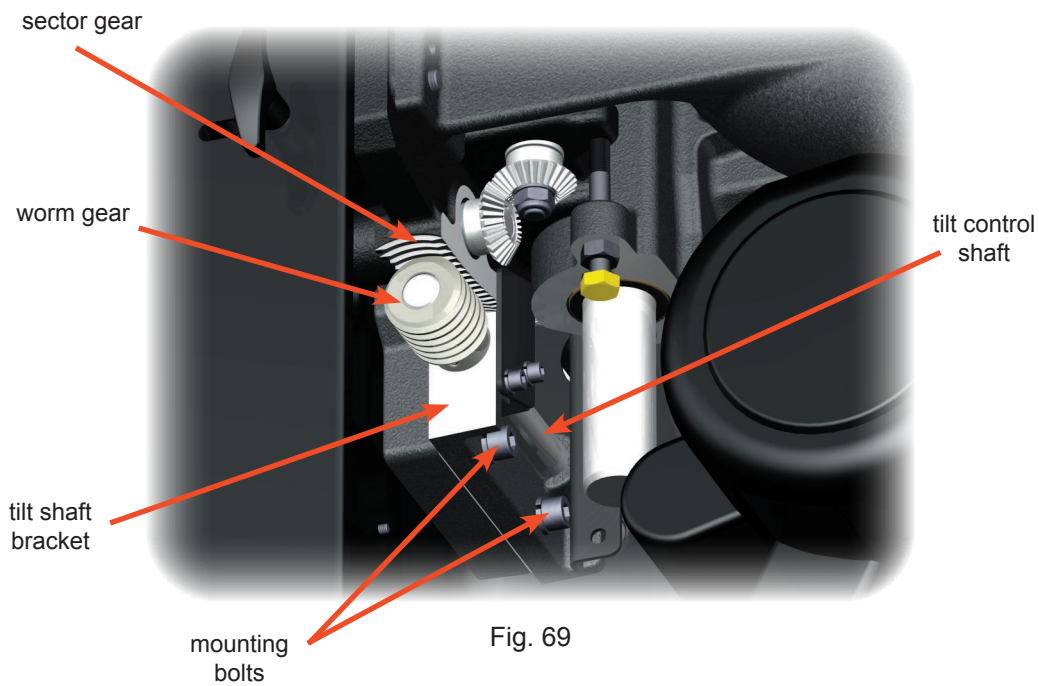

Making Adjustments to Your Saw

9. Adjusting the Miter Gauge:

The miter gauge bar includes three spring bearings which ensure a close fit between the miter gauge bar and the miter gauge slots in the table. The bearings can be adjusted to protrude further outward from the side of the bar to tighten the fit between the bar and the miter slots. Alternatively, the bearings can be adjusted inward to loosen the fit. To adjust the position of the spring bearings, insert a 2.5 mm hex wrench into the back of the bearing as shown in Fig. 70. Turn the wrench clockwise to tighten the fit, or counter-clockwise to loosen the fit.

The miter gauge also includes indexing stops to allow you to quickly set the gauge to -45° , 0° , and $+45^\circ$. If necessary, you can adjust these indexing stops to increase the precision of your miter cuts.

To begin, loosen the miter gauge head by turning the locking handle counter-clockwise about 1/2 turn (see Fig. 70).

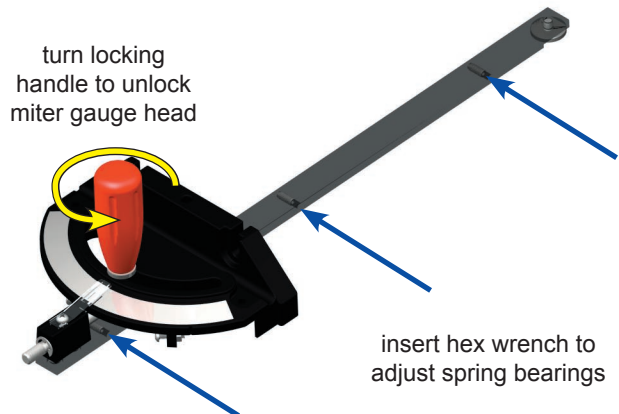

Fig. 70

Next, for the indexing stop you want to adjust, loosen the corresponding locking nut and turn the set screw counter-clockwise several turns. Place the miter gauge in either the left or right miter slot, and set a combination square to the desired angle (e.g., -45° , 0° , or $+45^\circ$). Position one leg of the square flush against the blade and rotate the miter gauge head until it is flush against the other leg of the square (see Fig. 71).

Next, turn the handle clockwise until it is tight to lock the miter gauge head at the correct angle. Make sure the indexing pin is pressed in toward the miter gauge bar, then turn the set screw clockwise until it hits against the indexing pin. Finally, tighten the locking nut to prevent the set screw from moving.

Repeat the above process for the other indexing stops if desired.

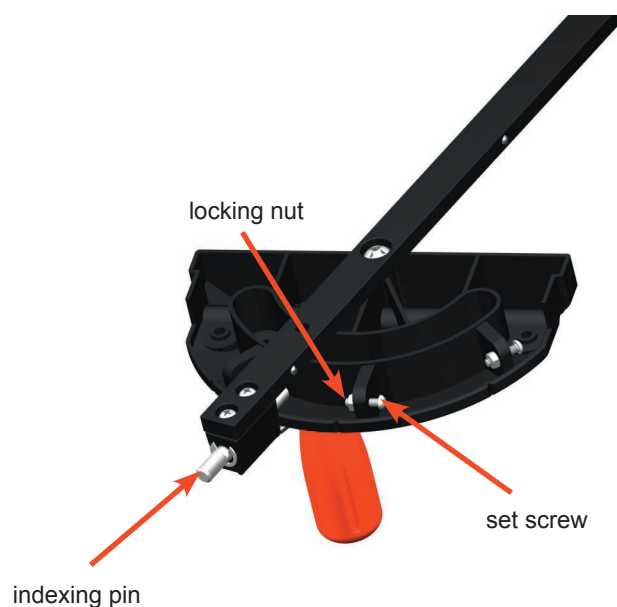

Fig. 71

Troubleshooting

Problem	Possible Cause(s)	Solution
The motor will not start and both LED's on the switch box are off.	1. There is no power to the saw.	1. Ensure that the electrical supply to the saw is on and that the correct voltage is being supplied.
	2. The disconnect switch is turned OFF.	2. Turn the disconnect switch to ON.
	3. There is no brake cartridge installed in the saw.	3. Install the brake cartridge.
	4. The brake cartridge is defective.	4. Replace the brake cartridge with a new cartridge.
The motor will not start and at least one LED on the switch box is on.	1. The safety system has detected a system error and is displaying an error code on the LED's.	1. Consult the list of System Status Codes to determine the cause of the error and the corrective action.
	2. The motor has overheated and tripped the thermal overload switch.	2. Wait 30 minutes to allow the motor to cool down, then try again.
The motor stopped unexpectedly during use but the brake did not activate.	1. The Start/Stop paddle was bumped.	1. Ensure the Start/Stop paddle is in the OFF position and restart the saw.
	2. The material being cut is overloading the safety detection system (e.g., green or wet wood).	2. Use different wood or cut in Bypass mode.
	3. The safety system has detected a system error and is displaying an error code on the LED's.	3. Consult the list of System Status Codes to determine the cause of the error and the corrective action.
	4. Electrical power to the system was lost at least temporarily.	4. Ensure that the electrical supply to the saw is on and that the correct voltage is being supplied.
The brake activated even though there was no accidental contact.	1. Some electrically conductive material contacted the blade, arbor or arbor pulley.	1. Make sure no metal or other conductive material is touching the blade, arbor or pulley. If you are trying to cut a conductive material, use Bypass mode.
	2. The spreader or riving knife came into contact with the blade.	2. Ensure that the spreader or riving knife is accurately aligned and securely clamped in place.
	3. There are voltage spikes on the electrical power supply to the saw.	3. Ensure that the electrical supply to the saw is steady and noise free. If necessary, install line conditioners.
	4. Other equipment near the saw is generating electrical noise.	4. Ensure the saw is not installed near sources of electrical noise.
	5. One of the sensor wires on the arbor block is loose.	5. Ensure that the screws that attach the three sensor wires to the bottom of the arbor block are tight.
Cannot remove the brake cartridge	1. The cartridge key is still installed.	1. Remove the cartridge key.
	2. The cartridge is bound up on the pivot pin and the positioning pin.	2. Wiggle the front and back of the cartridge until it is free, and then pull the cartridge off both pins evenly.
	3. The riving knife / blade guard clamp handle is in the way.	3. Swing the clamp handle fully upward to clear the cartridge.
	4. The trunnion brace is in the way.	4. Raise the blade elevation fully.

Troubleshooting

Problem	Possible Cause(s)	Solution
Cannot install the brake cartridge	1. The holes in the cartridge shell are not aligned with the pivot pin and positioning pin.	1. Make sure the mounting holes in the cartridge are aligned with the pivot and positioning pins.
	2. There is debris on the pivot or positioning pins, or in the cartridge mounting holes.	2. Make sure the pins and mounting holes are clean and free of obstructions.
	3. The blade is interfering with the brake pawl.	3. Adjust the brake positioning bolt to move the brake pawl away from the blade.
Cannot remove the cartridge key	1. The cartridge key is not turned to the UNLOCKED position.	1. Turn the key clockwise until it stops.
	2. The shaft of the cartridge key is binding in the cartridge or on the cartridge bracket.	2. Try turning/removing the key while pressing upward or downward on the key or cartridge.
Cannot install the cartridge key	1. The brake position is adjusted too far from the blade.	1. Turn the brake position bolt clockwise until the closest point between the brake pawl and the blade is about 1/16" to 1/8".
	2. The key is not rotated properly to align with the keyhole in the cartridge.	2. Rotate the key so that the handle is pointing directly toward the brake pawl.
	3. The shaft of the cartridge key is binding in the cartridge or on the cartridge bracket.	3. Try installing the key while pressing upward or downward on the key or cartridge.
Cannot turn saw on in Bypass mode.	1. The sequence for starting the saw in Bypass mode was not completed.	1. Follow the steps for starting the saw in Bypass mode exactly.
	2. The safety system has detected a system error and is displaying an error code on the LED's.	2. Consult the list of System Status Codes to determine the cause of the error and the corrective action.
The blade hits the brake pawl during installation.	1. The brake position is adjusted too close to the blade.	1. Turn the brake position bolt counter-clockwise until the closest point between the brake pawl and the blade is about 1/16" to 1/8".
	2. The blade is the wrong size.	2. Use only a 10" diameter blade with a standard brake cartridge, or an 8" dado set with a dado cartridge.
The gears sounds/feel rough when raising or lowering the blade.	1. There is dust or debris on the miter gears or elevation shaft.	1. Clean components and regrease.
	2. The lock nut below the vertical miter gear is too loose or too tight.	2. Tighten or loosen the lock nut as necessary.
	3. The elevation locking knob has not been released.	3. Turn the elevation locking knob counter-clockwise to release the elevation hand wheel.
There is play in the tilt control so that the tilt hand wheel can be turned slightly without changing the tilt angle of the blade.	1. The worm gear is not engaged fully on the front trunnion sector gear.	1. Adjust the position of the tilt control shaft as necessary to ensure the worm gear engages fully with the front trunnion sector gear.

Troubleshooting

Problem	Possible Cause(s)	Solution
The saw does not make accurate 45° or 90° cuts.	1. The tilt limit stops are not adjusted properly.	1. Adjust the tilt limit stops.
	2. The tilt angle indicator is not adjusted properly.	2. Adjust the tilt angle indicator.
	3. The miter gauge is not adjusted properly.	3. Adjust the miter gauge.
	4. The miter gauge slots are not aligned with the blade.	4. Align the miter gauge slots to the blade.
The material binds when making a rip cut.	1. The rip fence is not aligned with the blade.	1. Align the fence to the blade.
	2. The material is warped.	2. Select another piece of material.
	3. The feed rate is too high.	3. Try again at a lower feed rate.
	4. The spreader or riving knife is not aligned with the blade.	4. Align the spreader or riving knife.
The cuts are not even and/or clean.	1. The blade is dull.	1. Replace or sharpen the blade.
	2. The blade is coated with pitch, gum or other material.	2. Clean or replace the blade.
	3. The blade is not the correct blade for the material or cut.	3. Replace the blade.
The saw vibrates too much.	1. The blade is damaged or unbalanced.	1. Replace the blade
	2. The floor is uneven.	2. Move the saw to a level, even surface.
	3. The bearings are worn.	3. Replace the bearings.
	4. The belts are worn.	4. Replace the belts.
The motor starts slowly and/or fails to reach nominal speed.	1. The electrical supply voltage is too low.	1. Ensure that the correct voltage is being supplied to the saw.
	2. The electrical supply line to the saw is under-rated.	2. Ensure that the line that supplies power to the saw is sufficient for the required voltage and current.

Maintenance

1. SawStop Safety System:

The safety system in general requires little maintenance. The system performs continuous self-checks both before and during saw operation. If a problem is detected, the appropriate status code will be displayed on the LED's on the switch box.

Brake Cartridge:

Although the brake cartridge requires no maintenance, the condition of the cartridge should be checked after approximately every 10 hours of saw use. The cartridge is sealed to prevent the entry of dust or other contaminants into the housing. While a small amount of dust within the housing will not effect its operation, you should replace the cartridge if a significant amount of dust is visible inside the clear plastic housing. This would indicate that the cartridge housing seal has been damaged.

WARNING! never use a brake cartridge if more than a very small amount of dust can be seen inside the clear housing. If sawdust becomes packed inside the housing, the brake make fail to activate or may activate more slowly, thereby resulting in a serious personal injury.

2. Cabinet:

The interior of the cabinet should be kept free of accumulated saw dust, wood chips and other debris. Periodically check the dust inside the bottom of the cabinet and trunnion assembly. Vacuum out the cabinet and trunnion assembly if needed. The 4 inch flexible hose that extends between the bottom of the trunnion assembly and the dust port on the back of the cabinet can be detached from the trunnion assembly and used to vacuum out the cabinet using the dust collection system connected to the saw.

3. Elevation and Tilt Mechanisms:

The elevation and tilt gearing should be kept clean and well lubricated. Periodically check the condition of the elevation miter gears and threaded shaft, and the tilt worm gear and sector gear. If necessary, clean off any dust, dirt, pitch or other debris using a wire brush, and then reapply a good quality, non-hardening grease.

4. Table and Extension Wings:

The surface of the table and extension wings should be kept clean and free of any rust. If rust develops on the surface, you can remove it by spraying the surface with a light coat of WD-40® and scrubbing with a fine abrasive pad such as ScotchBrite® 7448 hand pads. After wiping the surface clean, coat it with a rust-inhibitive, surface protectant such as TopCote® or TopSaver™.

5. Belts:

The arbor belt and motor belt should be check periodically for wear or damage. You can access both belts by opening the belt access door. Replace any worn or damaged belts. In addition, check the tension of the motor belt. If light finger pressure on one side of the belt causes more than about 1/2" deflection, the belt should be tightened. The arbor belt cannot be tightened, and therefore must be replaced if it does not have sufficient tension to prevent slipping under load.

Cabinet Saw Dimensions

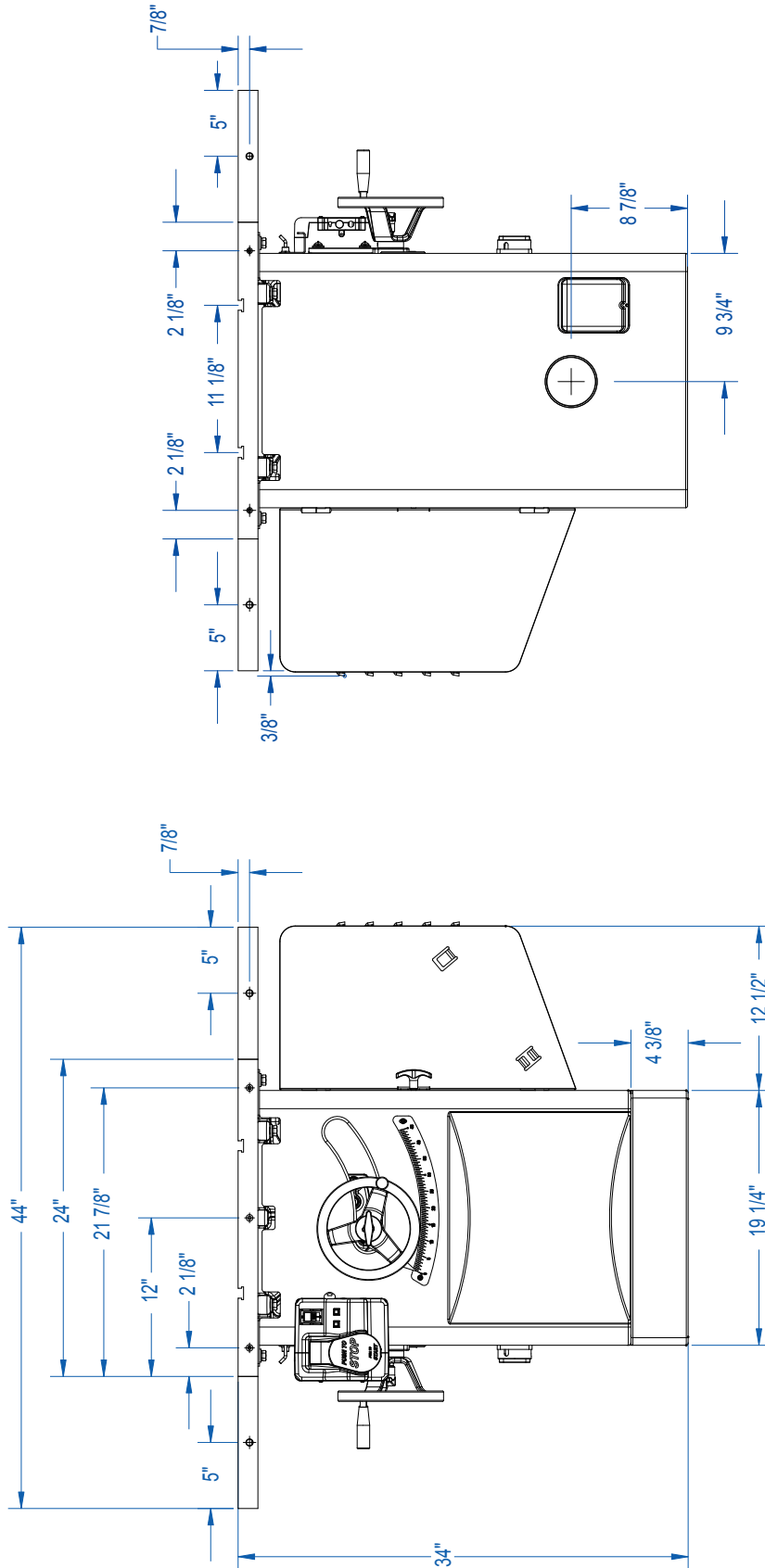

Rear View

Front View

Cabinet Saw Dimensions

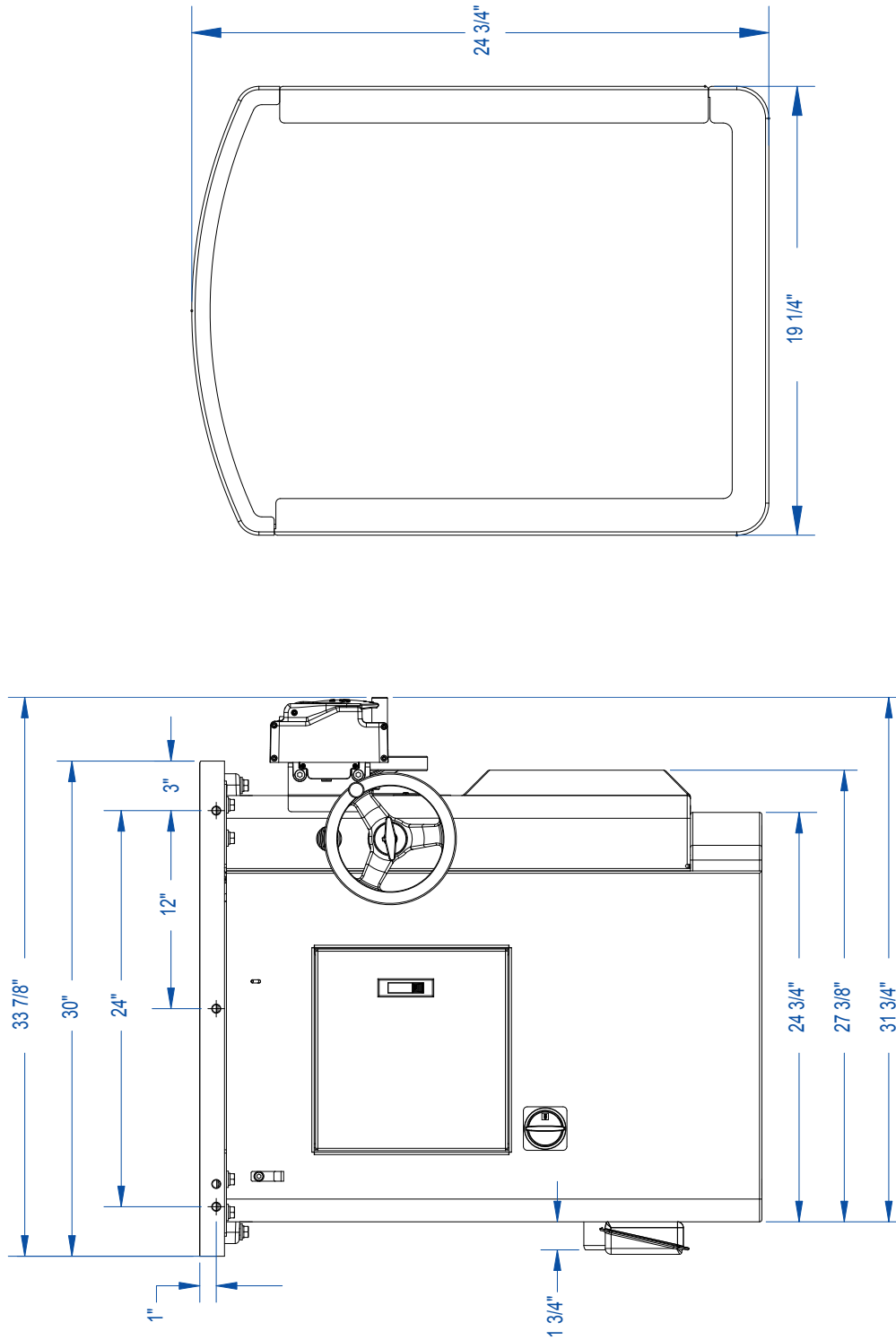

Left Side View

Footprint

Push Stick Construction

Squares are 1" .

Pushstick should be 1/2" to 3/4" thick.

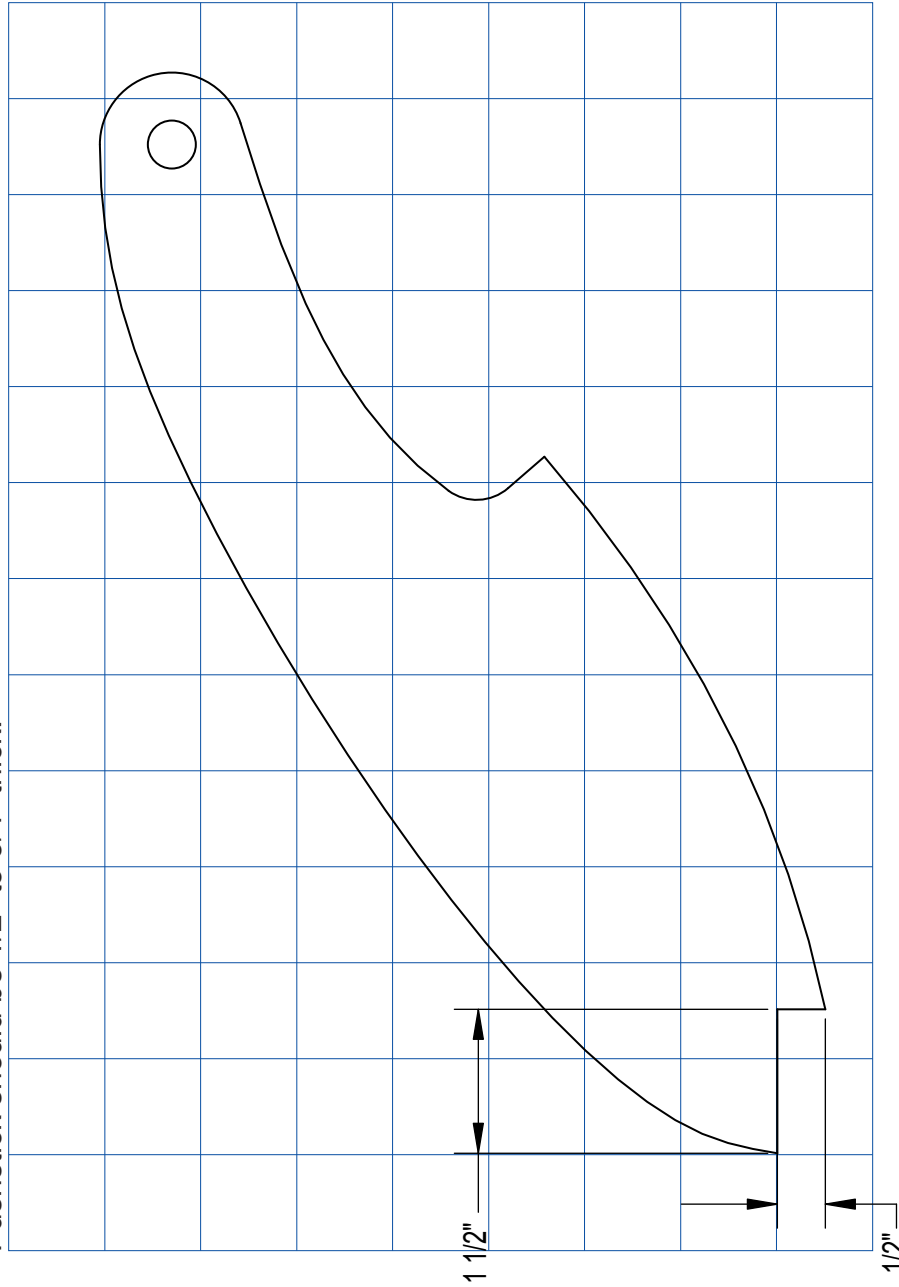

This diagram illustrates a typical pushstick. Pushsticks should be constructed from material that is sturdy and electrically non-conductive such as scrap wood. Pushsticks should always be used when rip cutting pieces narrower than 6 inches.

Featherboard Construction

1" squares.

Featherboard should be approximately 3/4" thick.

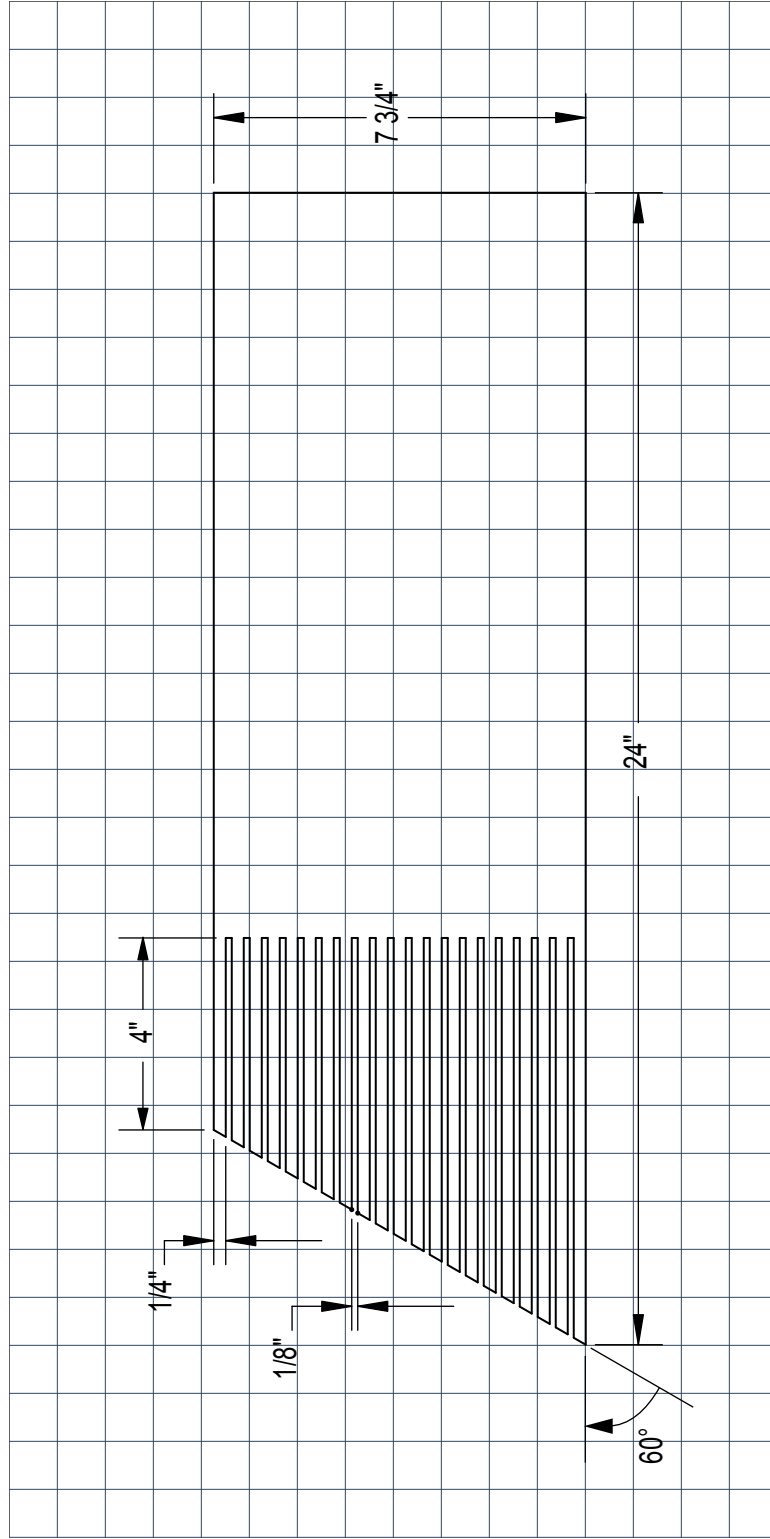

This diagram illustrates a typical featherboard. Featherboards should be constructed from good quality wood that is free of knots. Use Featherboards to help keep the material being cut in contact with the table, and to help prevent kickback. Do not use featherboards when cutting with the miter gauge.

Electrical Schematic — 230V, Single-Phase (3 and 5 HP)

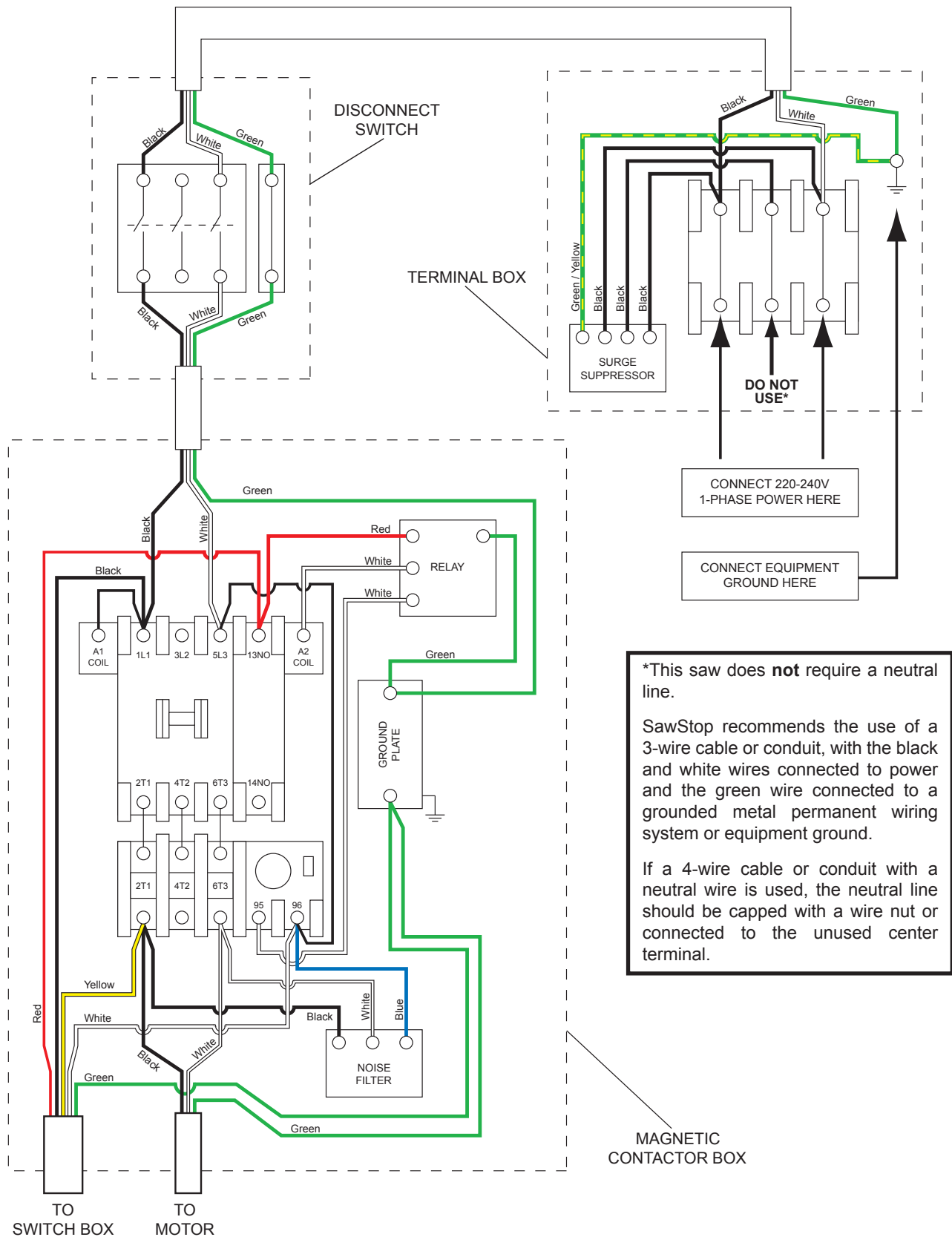

Electrical Schematic — 230V, Three-Phase (3 and 5 HP)

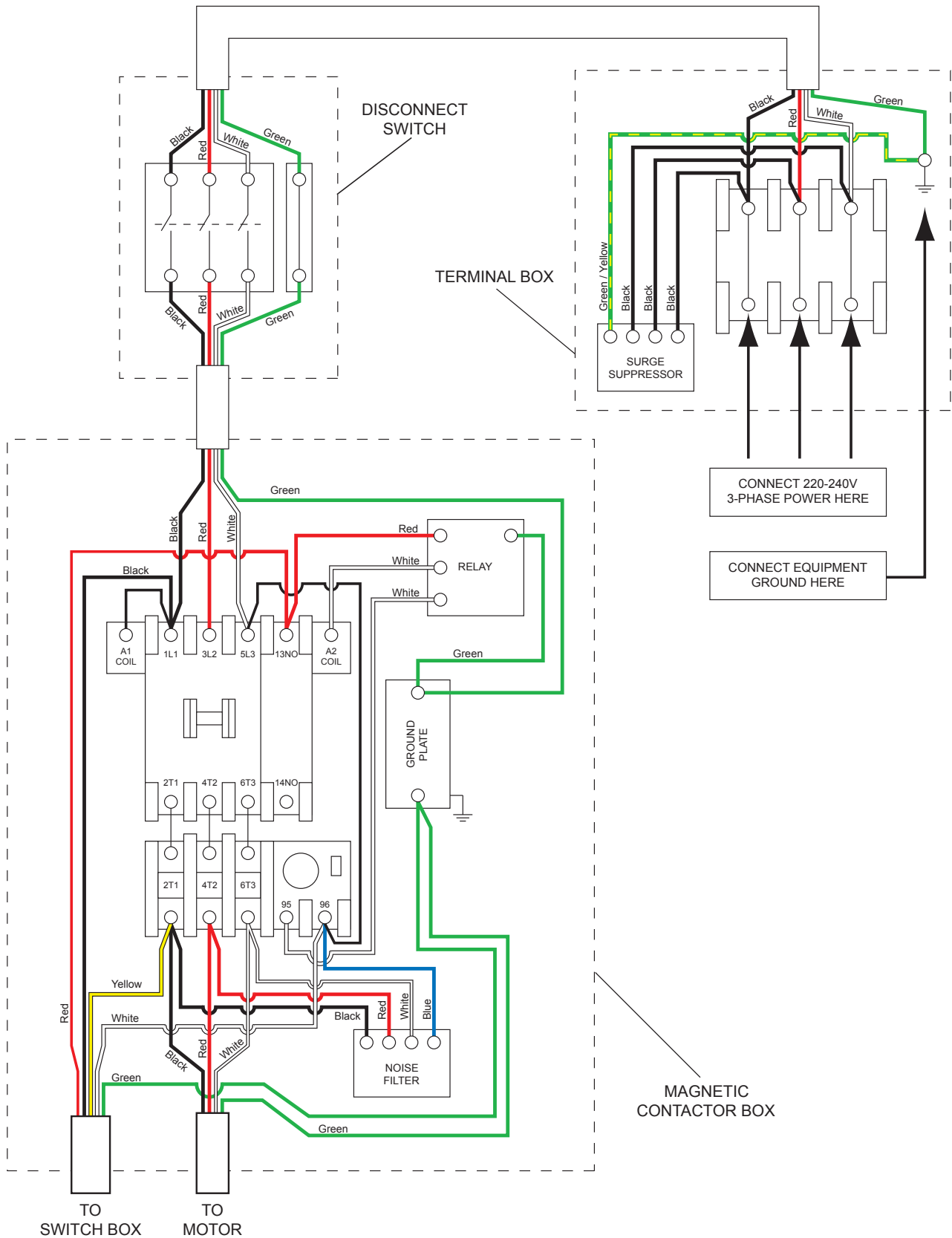

Electrical Schematic — 460V, Three-Phase (5 HP)

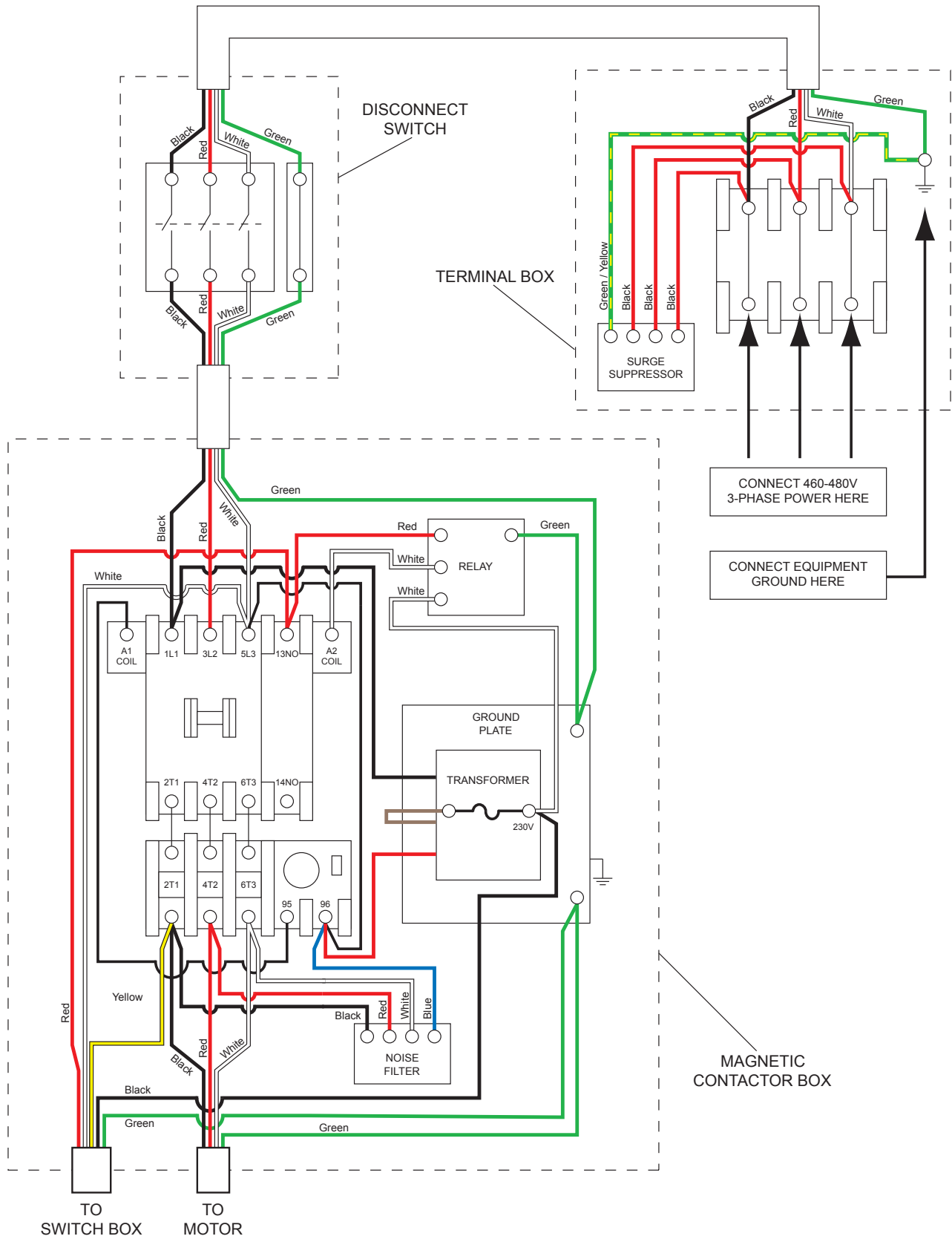

Cabinet and Table Assembly Exploded View

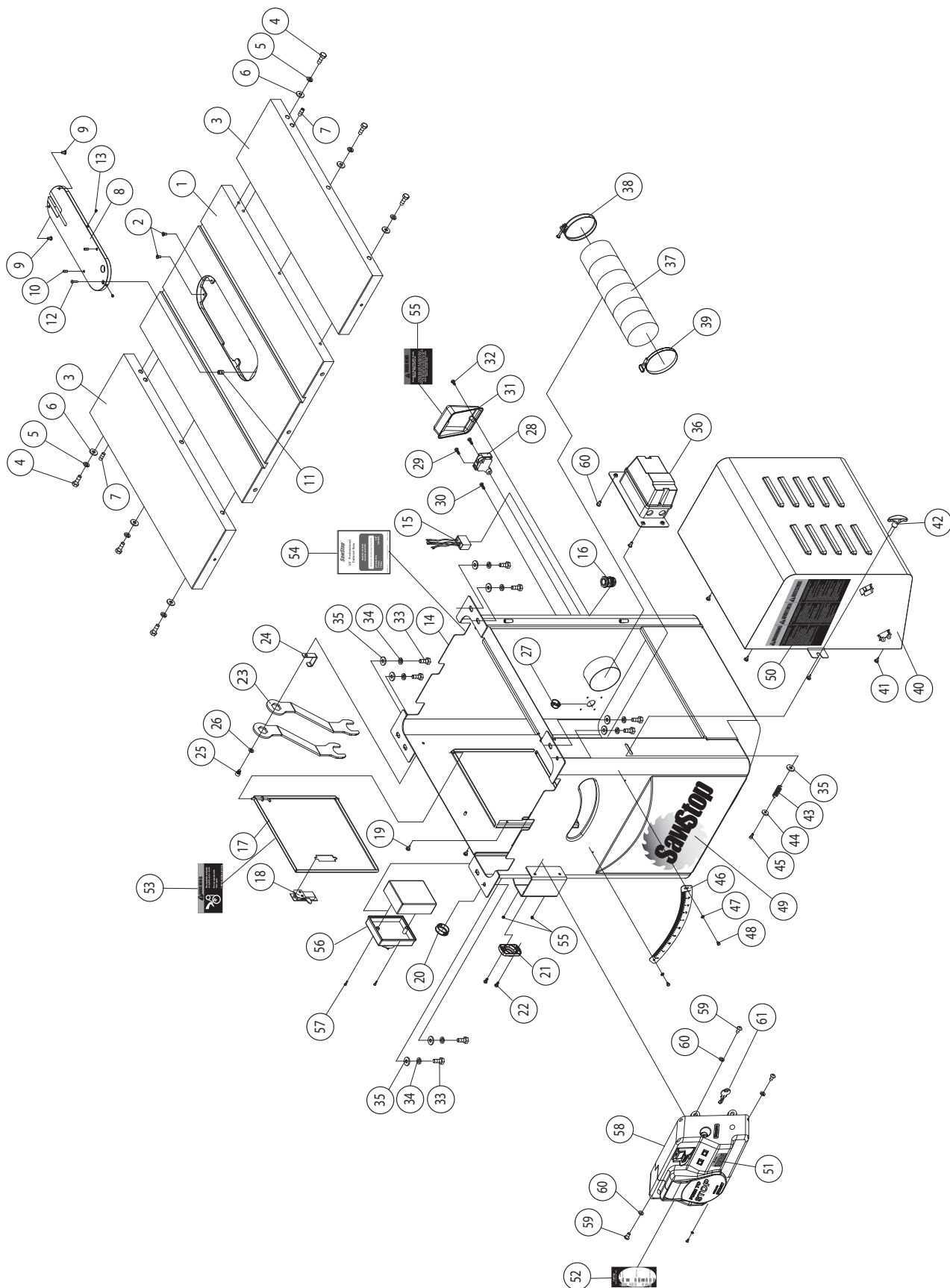

Cabinet and Table Assembly Parts List

No.	Description	Part No.	Qty.
1	Table	CB104 001	1
2	Rear Lock Down Screw for Insert	CB104 002	2
N/A	Extension Wing Assembly (complete)	CB104 003	2
3	Cast Iron Wing	CB104 004	2
4	M10x1.5x30 Hex Head Bolt	CB104 005	6
5	M10.2x18.5 Lock Washers	CB104 006	6
6	M10x25x3 Washers	CB104 007	6
7	M10x1.5x25 Socket Head Set Screw	CB104 008	2
8	Standard Insert Assembly (complete)	CB104 009	1
9	Rear Leveling Screw	CB104 010	2
10	M6x1x14 Front Leveling Screw	CB104 011	2
11	Threading Insert	CB104 012	1
12	M5x0.8x20 Front Lock Down Screw	CB104 013	1
13	M6x1x8 Set Screw	CB104 014	2
14	Cabinet	CB104 015	1
15	Surge Protector	CB104 016	1
16	Strain Relief Coupling	CB104 017	1
17	Belt Access Door	CB104 018	1
18	Belt Access Door Latch	CB104 019	1
19	Door Latch Screw	CB104 020	2
20	Grommet for Cable Aperture	CB104 021	1
21	Cover Plate for Tilt Rod Aperture	CB104 022	1
22	M6x1.0x16 Phillips Head Screw	CB104 023	2
23	Blade Wrench	CB104 024	2
24	Wrench Bracket	CB104 025	1
25	M8x1.25x10 Socket Head Bolt	CB104 026	1
26	M8.2x15.4 Lock Washer	CB104 027	1
27	Grommet for Terminal Box	CB104 028	1
28	Terminal Block	CB104 029	1
29	M5x0.8x20 Phillips Head Screw	CB104 030	2
30	Equipment Ground Screw	CB104 031	1
31	Terminal Box Cover	CB104 032	1
32	3/16-24NCx1.4 Terminal Cover Screw	CB104 033	1
33	M17 Hex Head Bolt	CB104 034	8
34	M10.2 x 18.5 Lock Washer	CB104 035	9
35	M10x25x3 Washer	CB104 036	8
36	Contact Box	CB104 037	1
37	Dust Collection Hose	CB104 038	1
38	Quick-Release Hose Clamp	CB104 039	1
39	Hose Clamp	CB104 040	2
40	Motor Cover	CB104 041	1

Cabinet and Table Assembly Parts List

No.	Description	Part No.	Qty.
41	Bumper	CB104 042	4
42	Latch	CB104 043	1
43	Spring	CB104 044	1
44	M6.2x20x3 Washer	CB104 045	1
45	M5x0.8x12 Socket Head Bolt	CB104 046	1
46	Angle Ruler	CB104 047	1
47	M5.2x10x1 Washer	CB104 048	2
48	M5x0.8x8 Phillips Head Screw	CB104 049	2
49	SawStop Label	CB104 050	1
50	Motor Cover Warning Label	CB104 051	1
51	Main Power Warning Label	CB104 052	1
52	System Status Codes Label	CB104 053	1
53	Warning Label for Belt Access Door	CB104 054	1
	Specification Label (3HP/1PH/230Volt)	CB104 055	
	Specification Label (3HP/3PH/230Volt)	CB104 056	
54	Specification Label (5HP/1PH/230Volt)	CB104 057	1
	Specification Label (5HP/3PH/230Volt)	CB104 058	
	Specification Label (5HP/3PH/460Volt)	CB104 059	
	Terminal Box Label (230Volt/Single PH)	CB104 060	
55	Terminal Box Label (230Volt/Three PH)	CB104 061	1
	Terminal Box Label (460Volt/Single PH)	CB104 062	
56	Disconnect Switch	CB104 063	1
57	Disconnect Switch Mounting Screw	CB104 064	4
58	Switch Box Assembly (complete)	CB104 065	1
59	M8x1.25x16 Button Head Socket Screw	CB104 066	4
60	M8.2x15.4 Washer	CB104 067	4
61	Bypass Key	CB104 068	2

Internal Assembly Exploded View

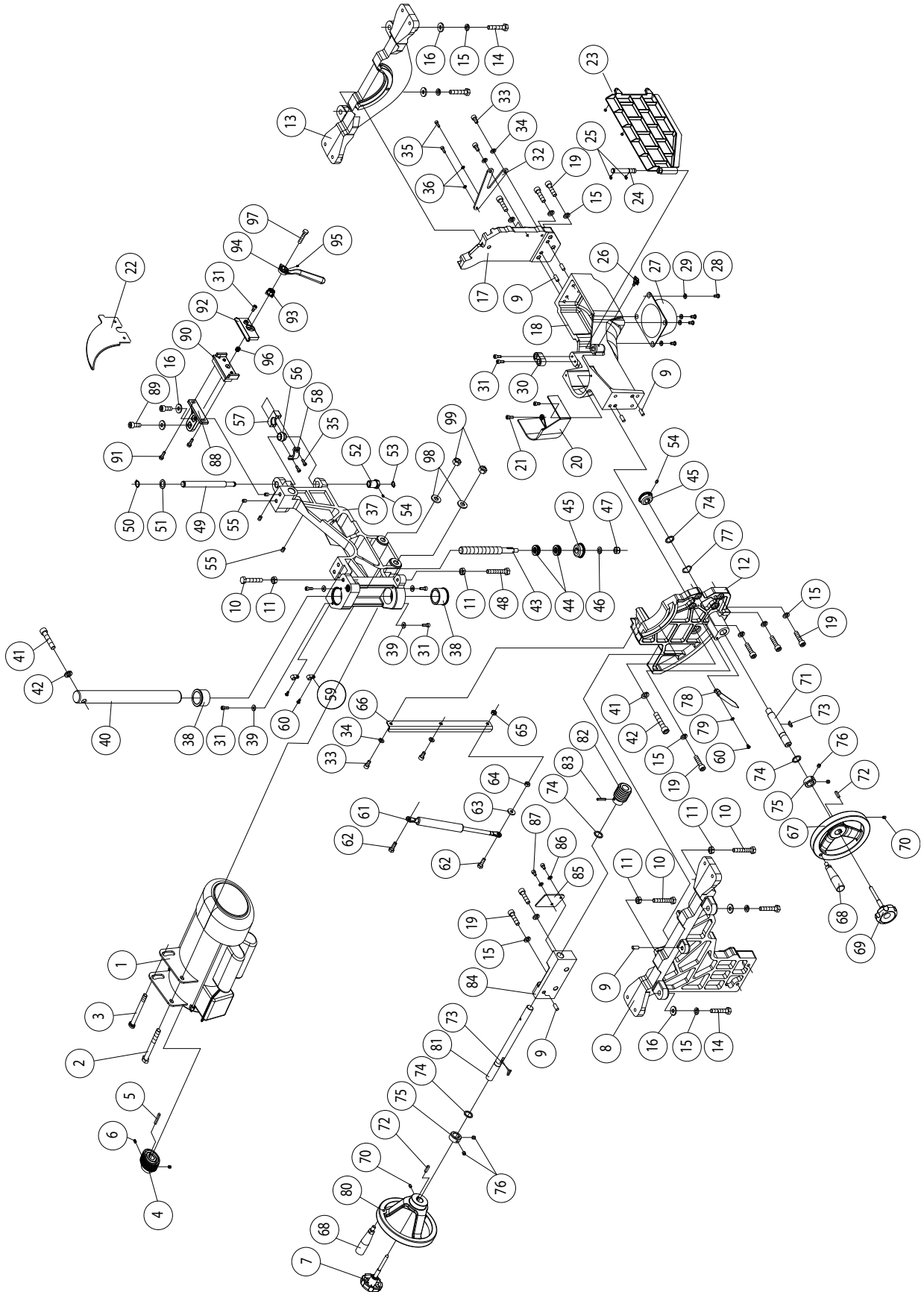

Internal Assembly Parts List

No.	Description	Part No.	Qty.
1	Motor		1
	3HP, 1PH, 230V, 60Hz, TEFC Motor	CB104 069	
	3HP, 3PH, 230V, 60Hz, TEFC Motor	CB104 070	
	5HP, 1PH, 230V, 60Hz, TEFC Motor	CB104 071	
	5HP, 3PH, 230V, 60Hz, TEFC Motor	CB104 072	
	5HP, 3PH, 460V, 60Hz, TEFC Motor	CB104 073	
2	M12x1.75x110 Hex Head Bolt	CB104 074	1
3	M12x1.75 Motor Positioning Bolt	CB104 075	1
4	Motor Pulley	CB104 076	1
5	M5x5x30 Key	CB104 077	1
6	M6x1.8 Set Screws	CB104 078	2
7	Tilt Elevation Lock Knob	CB104 079	1
8	Front Trunnion Bracket	CB104 080	1
9	Pin	CB104 081	6
10	M10x1.5x55 Hex Head Limit Bolt	CB104 082	3
11	M10x1.5 Nut	CB104 083	4
12	Front Trunnion	CB104 084	1
13	Rear Trunnion Bracket	CB104 085	1
14	M10x1.5x45 Hex Head Bolt	CB104 086	4
15	M10.2x18.5 Lock Washer	CB104 087	13
16	M10x25x3 Washer	CB104 088	6
17	Rear Trunnion	CB104 089	1
18	Trunnion Brace	CB104 090	1
19	M10x1.5x40 Socket Head Bolt	CB104 091	9
20	Front Dust Shroud	CB104 092	1
21	M6x1.0x16 Socket Head Screw	CB104 093	2
22	Riving Knife	CB104 094	1
23	Blade Shroud Door	CB104 095	1
24	Pivot Pin	CB104 096	1
25	Retaining Ring	CB104 097	2
26	Thumb Screw	CB104 098	1
27	Dust Hose Coupling	CB104 099	1
28	M6x1.0x15 Phillips Head Screw	CB104 100	4
29	M6.3x13x2 Lock Washer	CB104 101	4
30	Bumper	CB104 102	1
31	M6x1.0x12 Socket Head Screw	CB104 103	7
32	V-Bracket	CB104 104	1
33	M8x1.25x20 Socket Head Screw	CB104 105	4
34	M8.2x15.4 Lock Washer	CB104 106	12
35	M5x0.8x15 Socket Head Screw	CB104 107	4
36	M5.1x9.3 Lock Washer	CB104 108	2

Internal Assembly Parts List

No.	Description	Part No.	Qty.
37	Elevation Plate	CB104 109	1
38	Bushing	CB104 110	2
39	M6.7x16x2 Washer	CB104 111	4
40	Front Elevation Shaft	CB104 112	1
41	M12x1.75x60 Socket Head Bolt	CB104 113	2
42	M13x22.7 Lock Washer	CB104 114	2
43	Elevation Threaded Rod	CB104 115	1
44	Ball Bearing	CB104 116	2
45	Miter Gear	CB104 117	2
46	M10x20x1.5 Washer	CB104 118	1
47	M10x1.25 Lock Nut	CB104 119	1
48	M10x1.5x75 Hex Head Limit Bolt	CB104 120	1
49	Rear Elevation Shaft	CB104 121	1
50	Retaining Ring	CB104 122	1
51	M16.25.1.5 Washer	CB104 123	1
52	Eccentric Bushing	CB104 124	1
53	Retaining Ring	CB104 125	1
54	M5x0.8x8 Set Screw	CB104 126	2
55	M8x1.25x10 Set Screw	CB104 127	4
56	Spherical Bushing	CB104 128	1
57	Clamp Base	CB104 129	1
58	Clamp	CB104 130	1
59	Cable Mount	CB104 131	3
60	M5x0.8x8 Phillips Head Screw	CB104 132	3
61	Gas Spring	CB104 133	1
62	M8x1.25x25 Hex Head Bolt	CB104 134	2
63	M8.2x22x3 Washer	CB104 135	1
64	M8x1.25 Nut	CB104 136	1
65	M8x1.25 Nut	CB104 137	1
66	Gas Spring Bracket	CB104 138	1
67	Elevation Hand Wheel	CB104 139	1
68	Handle	CB104 140	2
69	Elevation Lock Knob	CB104 141	1
70	M6x1.0x6 Set Screw	CB104 142	2
71	Elevation Control Shaft	CB104 143	1
72	M5x5x22 Key	CB104 144	2
73	Key	CB104 145	2
74	Thrust Washer	CB104 146	4
75	Collar	CB104 147	2
76	5/16-18NC x 5/16 set screw	CB104 148	4
77	Wave Washer	CB104 149	1

Internal Assembly Parts List

No.	Description	Part No.	Qty.
78	Tilt Indicator	CB104 150	1
79	M5.2x10x1 Washer	CB104 151	3
80	Tilt Hand Wheel	CB104 152	1
81	Tilt Control Shaft	CB104 153	1
82	Worm Gear	CB104 154	1
83	M5x28 Pin	CB104 155	1
84	Tilt Control Shaft Support Bracket	CB104 156	1
85	Trunnion Guide Plate	CB104 157	1
86	M6.1x12.3 Washer	CB104 158	2
87	M6x1x1 Socket Head Screw	CB104 159	2
88	Splitter Mounting Plate	CB104 160	1
89	M10x1.5x25 Socket Head Bolt	CB104 161	2
90	Splitter Positioning Plate	CB104 162	1
91	M6x1x20 Socket Head Bolt	CB104 163	2
92	Clamping Plate	CB104 164	1
93	Cam Bushing	CB104 165	1
94	Clamp Handle	CB104 166	1
95	M4x0.7x6 Set Screw	CB104 167	1
96	Spring	CB104 168	1
97	M8x1x40 Hex Head Bolt	CB104 169	1
98	M13x28x3 Washer	CB104 170	2
99	M12x1.75 Lock Nut	CB104 171	2

Arbor Assembly Exploded View

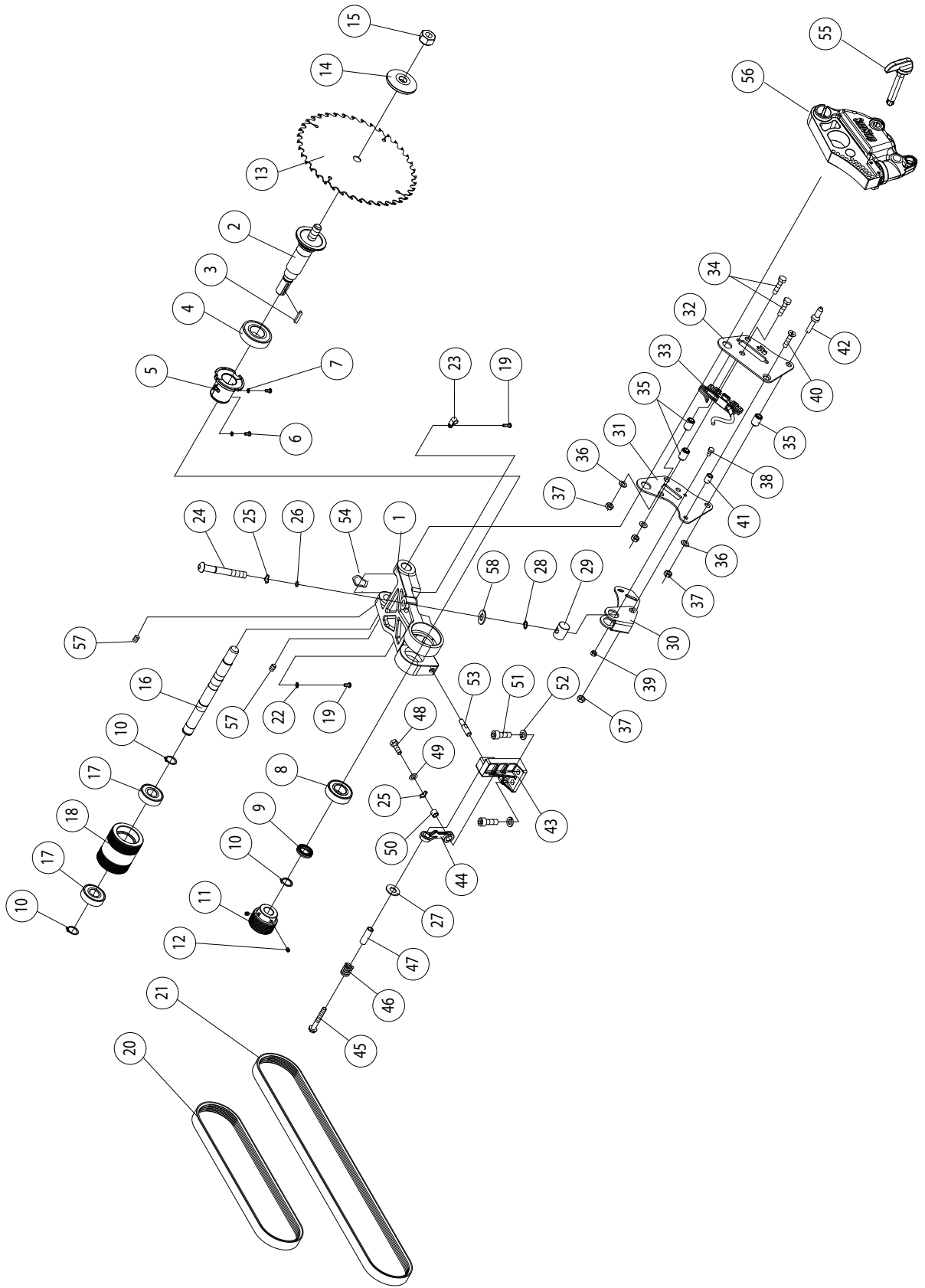

Arbor Assembly Parts List

No.	Description	Part No.	Qty.
1	Arbor Block	CB104 172	1
2	Arbor	CB104 173	1
3	M5x5x28 Key	CB104 174	1
4	Main Arbor Bearing	CB104 175	1
5	Electrode Shell	CB104 176	1
6	M4x0.7x6 Phillips Head Screws	CB104 177	2
7	BW-4 Lock Washer	CB104 178	2
8	Second Arbor Bearing	CB104 179	1
9	Bushing	CB104 180	1
10	Retaining Ring	CB104 181	3
11	Arbor Pulley	CB104 182	1
12	M6x1x8 Set Screw	CB104 183	2
13	Blade	CB104 184	1
14	Blade Washer	CB104 185	1
15	Blade Nut	CB104 186	1
16	Pivot Shaft	CB104 187	1
17	Bearing	CB104 188	2
18	Double Pulley	CB104 189	1
19	M5x0.8x10 Phillips Head Screw	CB104 190	2
20	Arbor Belt	CB104 191	1
21	Motor Belt	CB104 192	1
22	BW-5 Lock Washer	CB104 193	1
23	Cable Mount	CB104 194	1
24	Brake Positioning Bolt	CB104 195	1
25	Wave Washer	CB104 196	2
26	O-Ring	CB104 197	1
27	M 13.5x28x2 Washer	CB104 198	2
28	Retaining Ring	CB104 199	2
29	Barrell Nut	CB104 200	1
30	Cartridge Bracket Link	CB104 201	1
31	Cartridge Bracket Back Plate	CB104 202	1
32	Cartridge Bracket Face Plate	CB104 203	1
33	Cartridge Bracket Cable	CB104 204	1
34	M8x1.25x35 Hex Head Bolt	CB104 205	2
35	Spacer	CB104 206	3
36	M8.2x15.4 Washer	CB104 207	3
37	M8x1.25 Nut	CB104 208	4
38	M6x1x12 Hex Head Bolt	CB104 209	1
39	M6x1 Nut	CB104 210	1
40	M8x1.25x35 Phillips Pan Head Bolt	CB104 211	1
41	Spacer	CB104 212	1

Arbor Assembly Parts List

No.	Description	Part No.	Qty.
42	Threaded Pin	CB104 213	1
43	Retraction Bracket	CB104 214	1
44	Retraction Pawl	CB104 215	1
45	M8x1.25x55 Hex Head Bolt	CB104 216	1
46	Spring	CB104 217	1
47	Sleeve	CB104 218	1
48	M8x1.25x25 Hex Head Bolt	CB104 219	1
49	M8.5x16x1 Washer	CB104 220	1
50	Sleeve	CB104 221	1
51	M10x1.5x25 Socket Head Bolt	CB104 222	2
52	M10.2x18.5 Washer	CB104 223	2
53	Retraction Pin	CB104 224	1
54	Wave Washer	CB104 225	1
55	Brake Cartridge Key	CB104 226	1
56	Brake Cartridge for 10" Blade	SBC10 001	1
57	Arbor Friction Set Screw	CB104 227	3
58	M13.5x32x2.3 Flat Washer	CB104 228	1

Miter Gauge and Blade Guard Assemblies Exploded View

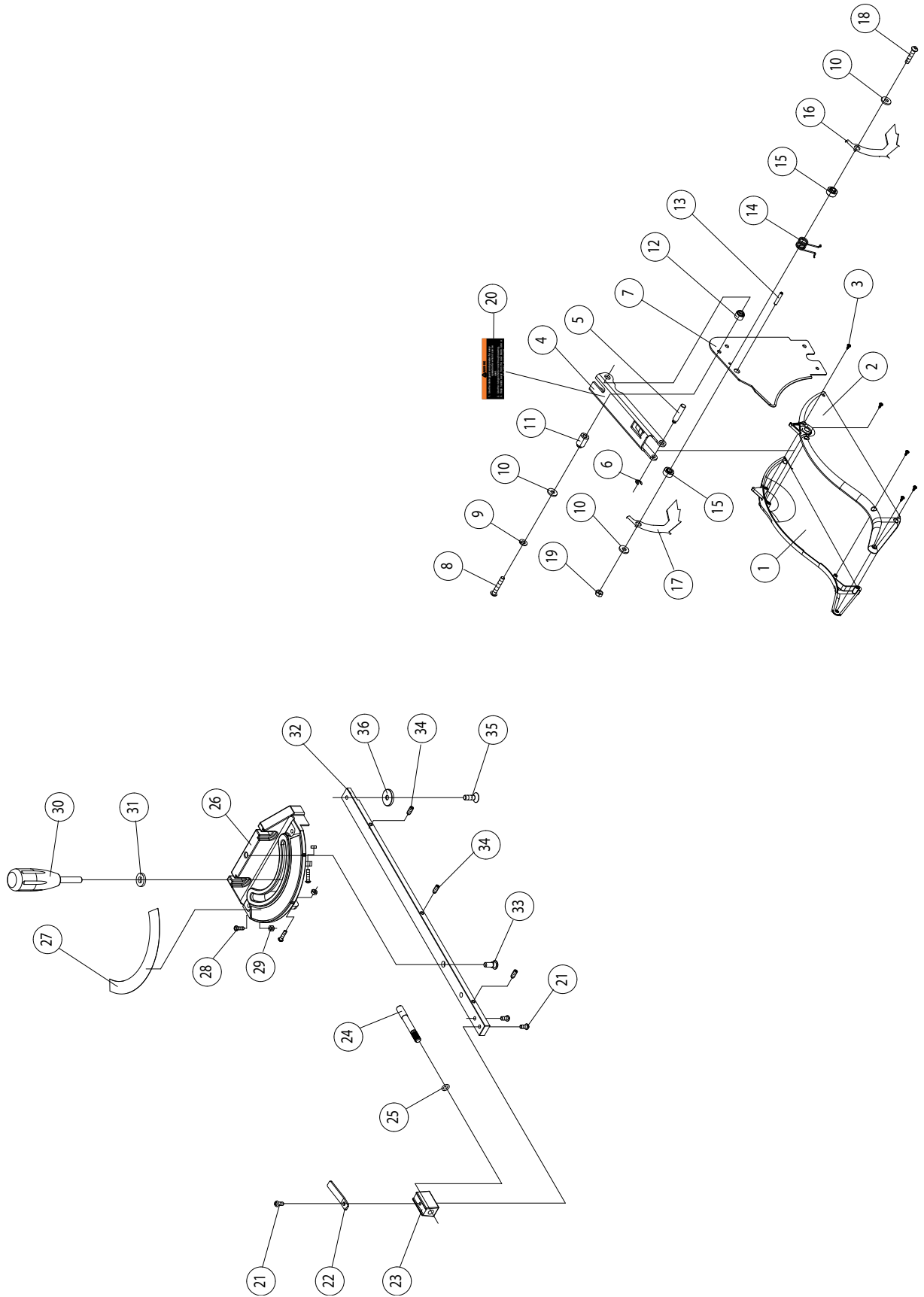

Miter Gauge and Blade Guard Assemblies Parts List

No.	Description	Part No.	Qty.
	Blade Guard Assembly (complete)	CB104 229	1
1	Guard Left Half	CB104 230	1
2	Guard Right Half	CB104 231	1
3	M3x1.06x6 Round Head Phillips Screw	CB104 232	5
4	Pivot Arm	CB104 233	1
5	Pivot Pin	CB104 234	1
6	E-Clip	CB104 235	1
7	Splitter	CB104 236	1
8	M6x1x35 Button Head Socket Screw	CB104 237	1
9	M6.1x12.3 Lock Washer	CB104 238	1
10	M6.7x16x2 Washer	CB104 239	3
11	Sleeve	CB104 240	1
12	Internally Threaded Sleeve	CB104 241	1
13	M4x25 Spring Pin	CB104 242	1
14	Spring	CB104 243	1
15	Sleeve	CB104 244	2
16	Anti-Kickback Pawl Right	CB104 245	1
17	Anti-Kickback Pawl Left	CB104 246	1
18	M6x1x30 Button Head Socket Screw	CB104 247	1
19	M6x1 Locking Nut	CB104 248	1
20	Blade Guard Warning Label	CB104 249	1
	Miter Gauge Assembly (complete)	CB104 250	1
21	3/16-24NCx1/4" Phillips Head Screw	CB104 251	3
22	Angle Indicator	CB104 252	1
23	Mounting Block	CB104 253	1
24	Indexing Pin	CB104 254	1
25	E-Clip	CB104 255	1
26	Miter Gauge Head	CB104 256	1
27	Angle Ruler	CB104 257	1
28	5/32-32NCx5/8" Phillips Head Screw	CB104 258	3
29	5/32-32NC Nut	CB104 259	3
30	Handle	CB104 260	1
31	M8.5x18x3 Washer	CB104 261	1
32	Bar	CB104 262	1
33	Gauge Head Mounting Screw	CB104 263	1
34	Spring Bearing	CB104 264	3
35	M6x1x6 Pan Head Phillips Screw	CB104 265	1
36	Size Washer	CB104 266	1

Accessories

SawStop recommends the following accessories for use with your SawStop cabinet saw. Contact SawStop at 503-638-6201 for current pricing and to place an order.

1. SawStop Brake Cartridges:

Standard Brake Cartridge for 10" saw blades p/n SBC10 001

Dado Brake Cartridge for 8" dado sets p/n DBC8 001

2. SawStop Zero-Clearance Table Insert:

Standard Zero-Clearance Table Insert Assembly
—phenolic core with melamine surfaces p/n CB104 009

Dado Zero-Clearance Table Insert Assembly
—solid hard wood p/n CB104 267

3. Tools:

3 mm Hex L-wrench p/n CB104 268

5 mm Hex L-wrench p/n CB104 269

8 mm Hex L-wrench p/n CB104 270

4. Rip Fences and Extension Tables:

T-Glide™ Professional Fence p/n 104-12-000

36" Rails p/n 104-13-000

36" Extension Table (for use with 36" rails) p/n 104-14-000

52" Rails p/n 104-15-000

52" Extension Table (for use with 52" rails) p/n 104-16-000

Index

A

Accidental Contact: 9-11, 27, 30, 40, 43

Adjustments

brake position: 7, 18-19, 30, 43

miter gauge: 3, 35-36, 65

table insert: 3, 22, 60, 65

limit stops

elevation: 3, 26, 49, 56-57

tilt: 3, 26, 49, 58-60

tilt gearing: 3, 64

Alignment

blade elevation assembly: 3, 26, 45-47, 50-53, 55

spreader and riving knife: 3, 15, 20-21, 34, 61, 63

table: 26, 49-52

tilt axis: 3, 52-55

Ambient Temperature: 30

Anti-Kickback Pawl(s): 12, 33, 38, 62

Arbor

belt: 11, 14-15, 69

block: 14, 18, 44-45, 56-57

diameter: 15

nut: 11, 14, 17-18, 24

runout: 15

washer: 11, 14, 17-18

B

Belt Access Door: 13, 58, 69

Blade(s)

abrasive blade: 10, 18, 30

coating(s): 10, 16-17, 68

coast down: 9, 11, 27, 30-31

dado set (see Dado Sets)

damaged: 10-11, 68

elevation: 2-3, 15, 18, 22, 26, 33, 36-37, 39, 45-47, 49, 51, 56-59, 61, 66

kerf: 15, 21, 34, 61-62

non-conductive: 10, 18, 30

retraction: 11, 44

standard blade: 10, 12-13, 15, 30, 56-60, 67

wrench: 12-13, 17

Blade Guard

anti-kickback pawl: 12, 33, 38, 62

guard: 2, 6-7, 10, 12-13, 15, 20-22, 25, 33-34, 37-38, 87-88

spreader: 3, 7, 12-15, 21-22, 33, 38-39, 43, 61-63

Index

Brake

activation: 3, 9-11, 22, 27, 30-32, 40, 44, 57, 63, 66, 69
cartridge: 3, 6-7, 9-12, 14-15, 18-20, 30, 32, 39-44, 66-67, 69, 89
cartridge key: 12, 14, 20, 30, 40-41, 43, 66-67
changing the brake cartridge: 3, 7, 9, 18, 20, 30, 39-44, 66-67, 69
position adjustment: 14, 18-19, 42-43, 67
pawl: 30, 33, 39-40, 42-44, 62, 67

Brake Positioning Bolt: 14, 18-19, 42-43, 67

Bypass

mode: 2, 4, 9-10, 30-32, 66-67
switch: 7, 12, 24, 30
key: 13, 24, 32

C

Cabinet Saw

dimensions: 70-71
specifications: 2, 15

Cartridge (see Brake Cartridge)

Clamping Handle (for spreader or riving knife): 14, 21, 39, 43, 66

Coast-down: 9, 11, 27, 30-31

Cross-cuts: 3, 34, 36

Cutting

cross-cuts: 3, 34, 36
narrow cuts: 20, 33
non-through cuts: 10, 20, 34, 38, 63
rabbet: 20, 33-34, 63
rip cuts: 3, 33, 37-38, 49, 72
through: 20, 26, 37

D

Dado

brake cartridge: 10-11, 15, 40, 89
cuts: 10, 33-34, 38, 40
insert: 15, 89
set: 2, 10-11, 17-18, 21, 39-40, 42-43, 67, 89

Depth of Cut: 15, 35

Detection of Accidental Contact: 1, 9-11, 17, 30-31, 40

Dial Test Indicator: 46-51, 53, 55

Disconnect Switch: 2, 6, 9, 13, 24-25, 27, 39, 44-45, 66

Dust

collection: 2, 15, 23, 69
hazard: 23
port: 13, 15, 23, 69

Dust Shroud Door: 14, 19, 39, 41, 43

Index

E

Electrical

- grounding: 5, 24
- power connection: 2, 5, 7, 18, 23-24, 45, 66-68
- schematic: 74-76
- wiring: 11

Elevation

- changing the blade elevation: 2, 18, 26, 36-37, 45, 66
- elevation handwheel: 13, 26-27, 44, 56-59
- elevation locking knob: 26, 67
- elevation plate: 14, 45, 48, 55-57
- elevation threaded rod: 14
- limit stops: 3, 26, 44, 49, 56-57

Extension Wing(s)

- cleaning: 2, 16
- assembly: 2, 16

F

Featherboard(s): 21, 38, 73

Front Elevation Shaft: 45, 47, 67

Front Trunnion: 14, 45, 49-52, 58-59, 64

Front Trunnion Bracket: 14, 50-52, 58-59, 64

G

Green Wood: 31

Guard (see Blade Guard)

H

Hand Wheel(s): 2, 12-13, 15, 17, 26-27, 44, 46, 49, 53, 56-60, 64

I

Insert (see Table Insert)

K

Kerf: 15, 21, 34, 61-62

Kickback: 7, 20, 36, 38, 73

Index

L

LED(s): 27, 29, 32, 43-44, 60-61, 66-67, 69

Limit Stop(s)

elevation: 3, 26, 44, 49, 56-57

tilt: 3, 26, 49, 58-60

Lock-Out: 28

M

Main Power Switch: 6, 9, 11, 27-31, 39, 44-45

Maintenance: 3-4, 25, 29, 69

Miter Gauge

adjustment: 3, 35-36, 65, 68

indexing pin: 35, 65

index stop(s): 35

slot(s): 13, 15, 34-36, 46, 49-55, 65, 68

spring bearings: 35, 65

use: 3, 34-36

Motor Belt: 14, 69

Motor Cover: 13, 19, 34, 41, 43, 54, 56-57, 59

O

Overload (of the detection system): 31, 66

P

Push Stick: 10, 37, 72

R

Rear Elevation Shaft: 45, 47-48, 53, 67

Rear Trunnion: 14, 45, 50-52, 54-55

Rear Trunnion Bracket: 14, 50-52

Retraction: 9, 11, 44, 57

Rip

cutting: 3, 33, 37-38, 49, 72

fence: 2, 6, 16, 20, 33, 36-38, 49, 68

narrow rip cuts: 33

Riving Knife: 2-3, 12-15, 20-21, 25, 33-34, 38-39, 43, 61-63, 66, 68

Index

S

- Saw Placement: 2, 16
- SawStop Safety System
 - activation: 3, 9-11, 22, 27, 30-32, 40, 44, 57, 63, 69
 - bypass mode: 2, 4, 7, 9-10, 12-13, 24, 30-32, 66-67
 - operation: 2-4, 9-11, 18, 24-25, 27, 29-32, 39, 43-44, 69
 - system status codes(s): 2, 9, 29-32, 43-44, 66-67
- ScotchBrite®: 69
- Setting Up Your Saw: 2, 16-25
- Shipping Weight: 15
- Single-Phase Power: 8, 15
- Specification Label: 24
- Splitter (spreader): 3, 7, 12-15, 21-22, 33, 38-39, 43, 61-63, 66, 68
- Standby Mode: 30
- Start/Stop Paddle: 27, 30-32, 39, 66
- Static Electricity: 11
- Switch Box: 13, 24, 27, 29, 43-44, 66, 69
- System Status Code(s): 2, 9, 29-32, 43-44

T

- Table Inserts
 - adjustment: 3, 22, 60
 - dado insert: 15, 89
 - standard insert: 2-3, 7, 11-13, 22, 33, 39, 43, 51, 60-61, 89
- Terminal Box: 13, 24
- Thin-kerf blade (see Blades)
- Three Phase Power: 8, 15, 18, 24
- Tilt
 - angle: 2-3, 13, 18, 26, 33, 36-37, 39, 46, 49, 51-54, 58-61, 64
 - angle indicator: 3, 13, 26, 58-59, 68
 - angle scale: 13, 26
 - hand wheel: 2, 12-13, 17, 26, 49, 53, 58-60, 64
 - limit stop: 3, 26, 49, 58-60, 68
 - locking knob: 26
- TopCote®: 16, 69
- TopSaver™: 16, 69
- Troubleshooting: 3, 66-68
- Trunnion Brace: 19, 57, 66

Index

U

Unpacking Your Saw: 2, 12

Using Your Saw: 2, 26-43

V

V-bracket: 54-55

W

Warning Labels: 2, 7

Warranty: 1-2, 4, 11, 24

WD-40®: 69

Wet Wood: 31

Worm Gear: 64, 67, 69

Z

Zero-Clearance Table Inset (see Table Inset)

SawStop, LLC
22409 S.W. Newland Road
Wilsonville, Oregon 97070
www.sawstop.com

phone 503-638-6201
fax 503-638-8601
email: info@sawstop.com