

# Valves or Transistors?

colouring vs. reality  
nostalgia vs. progress  
advocate vs. analyst

## Build this:

- Programmable Crystal Oscillator
- Handy Opamp Tester
- Play Solitaire

## Background:

- Altium FPGA Live Design Kit
- Introducing ARMee
- Anti-Noise Systems

## High-End Power Amp

2 x 40 high-class watts



## EL156

### Valve Monoblock



# PAGM

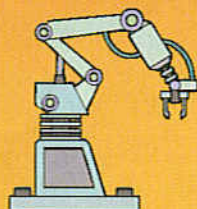
The leaders in PIC development

**FROM**

**£99**



**EASE OF USE**



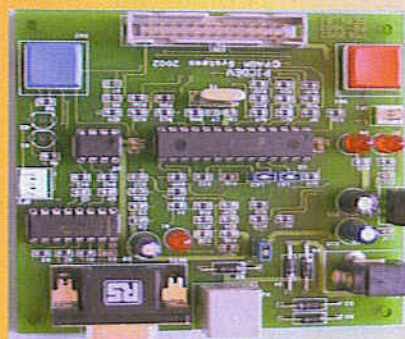
**AUTOMATION**



**SCRIPTABILITY**

- ◆ All you need to get started with PIC
- ◆ Industry standard/quality board
- ◆ Open the box and get coding
- ◆ Available with C compiler or use our PicScript to write programs using simple commands...

**NO ASSEMBLER,  
NO COMPILER,  
JUST WRITE AND RUN**



PicDev Board with PicScript

**£99.00** (plus p+p)

This is a complete development suite for the novice or non programmer.

It is shipped with:

- PicDev Board
- PicShell and PicScript software
- Breakout board
- Cables
- Example scripts

PicDev Board with C Compiler

**£165.00** (plus p+p)

This is a complete development suite for the more advanced programmer.

It is shipped with:

- PicDev Board
- PicShell and PicScript software
- C compiler
- Breakout board
- Cables
- Example scripts
- ICD1

Both items require

- PC with serial port available
- Power supply adapter

**To order:**

[www.pagm.co.uk](http://www.pagm.co.uk)

[sales@pagm.co.uk](mailto:sales@pagm.co.uk)

Tel: +44 (0)1792 891927

# Easy, Safe, Fast...



**FREE**  
424 page  
Catalogue

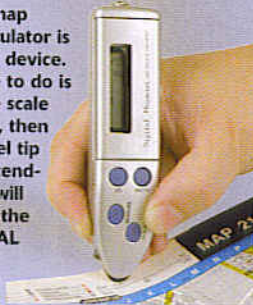
**JUST ONE OF OUR MANY  
GREAT PRE-BUILT & TESTED  
CONSUMER PRODUCTS!**

### Map Reading Made Easy!

XC-0375 £5.50

The digital map distance calculator is truly a great device. All you have to do is program the scale of your map, then roll the wheel tip along the intended route. It will then display the **ACTUAL REAL WORLD DISTANCE** in miles

(or kilometres) on the LCD. It is light and compact at around 125mm long.



## We Stock...

Electronic Components

Electronic Project Kits

Test & Measurement Equipment

Power Products & Accessories

Audio & Video Equipment & Accessories

Computer & Telecoms Accessories

Security & Surveillance Equipment

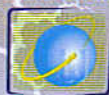
# Jaycar

Electronics

Get Your **FREE UK Pounds Sterling Priced Catalogue** - all 424 pages!  
Just fill out the catalogue request form at [www.jaycarelectronics.co.uk/catalogue](http://www.jaycarelectronics.co.uk/catalogue)

Check our website!

- All of our 6,000+ products with search facilities.
- 128-bit secure on-line ordering - safe & secure.
- Over 3,500 product datasheets & application notes.
- And we're from Australia, so you can trust us!



Moreinfo?

[www.jaycarelectronics.co.uk](http://www.jaycarelectronics.co.uk)

### Get the Video Quality You Paid For With Our Doctor Video Kit

KC-5390 £29.00

Did you know that you are not getting the best picture from that expensive movie collection you paid good money for? Copy protection is put in place on videos and DVDs for a good reason, but this robs you of the true high quality reproduction that it is capable of. Get the quality you paid for and strip out these annoying signals! It supports composite and S-video signals and can be configured for NTSC or PAL format. Kit includes case, circuit board, all electronic components, and clear English instructions. Note: Some SMD soldering required. Caution: During signal conditioning, this unit removes copyright protection. Piracy is a crime, & Jaycar Electronics takes no responsibility for its potential for unlawful use.



### Remote Control Extender Kit MkII

KC-5209 £6.70

If you have a source device such as a DVD player running to a TV in another room, or perhaps a HiFi system with speakers in the other end of your house, you probably get tired of walking to the other room just to change tracks or fast forward etc. This project effectively transfers the IR signal from your remote control and re-transmits it in the other room! Kit includes case, circuit board, all electronic components, and clear English instructions.



### Theremin Synthesiser Kit

KC-5295  
£13.05

The Theremin is a weird musical instrument that was invented early last century but is still used today. The Beach Boys' classic hit "Good Vibrations" featured a Theremin. Kit includes a machined, silk-screened, and pre-drilled case, circuit board, all electronic components, and clear English instructions.

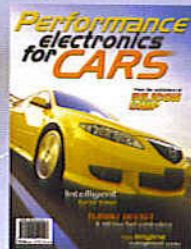
This product is now available pre-built and fully tested - Cat. AM-4025 £27.25



### Performance Electronics for Cars Book

BS-5080 £6.35

Australia's leading electronics magazine, Silicon Chip Magazine, has developed a range of projects for performance cars. There are 16 projects in total, ranging from devices for remapping fuel curves, to nitrous controllers, and more! The book includes all instructions, components lists, colour pictures, and circuit layouts. There are also chapters on engine management, advanced systems, DIY modifications, and more. Over 150 pages! All of the projects described are available in kit form, exclusively from Jaycar. Check out our website for all the details.



### 50MHz Frequency Meter Kit with LCD Display

KC-5369 £20.30

If you want a great value frequency meter, then this project is for you. It features Autoranging operation for ease of use, switching between its three ranges. High resolution of 0.1Hz up to 150Hz, 1Hz between 150Hz and 16MHz, and 10Hz above 16MHz. It can be powered by a 9V battery or wall adaptor (not included) and the case measures just 130 x 67 x 44mm. Kit includes case, circuit board, electronic components, and clear English instructions.



Log on to

[www.jaycarelectronics.co.uk/catalogue](http://www.jaycarelectronics.co.uk/catalogue)

for your **FREE** catalogue!

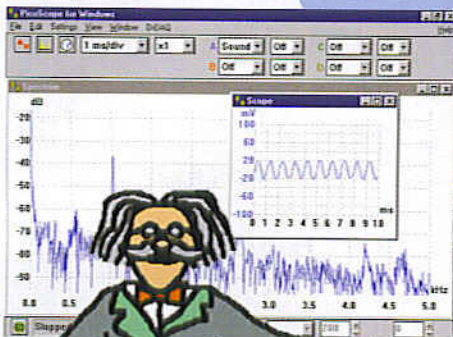
**0800 032 7241**

(Monday - Friday 09.00 to 17.30 GMT + 10 hours only)

For those that want to write:

100 Silverwater Rd Silverwater NSW 2128 Sydney Australia

# DrDAQ Data Logger



**Applications for DrDAQ**

For more information on the applications, please get in touch, following the links below.

**Light level** - Use a light sensor to look at how light, computer monitors and TV Screens are and sound level sensors to measure the decibel levels.

**Acoustic** - Use a PicoScope oscilloscope to show the sound waveforms produced by someone singing. Switch on the spectrum analyser to see the frequency components - what's the frequency of the notes?

**Temperature** - Measure the temperature of a sound source with a constant level and plot how it decays with distance.

**Musical Instruments** - Look at the scope waveforms and FFT spectrum of different instruments.

**Light level** - How does light level decay with distance from source?

**Acid Base Titration** - Experiment with different materials to see which can be used to measure the pH and temperature.

**Acid Rain** - Measure the pH of collected rainwater. Needs careful calibration.

**Endothermic Reactions** - Measure the temperature as ammonium nitrate is dissolved in water.

**Dry and Night** - Measure temperature, light and humidity over a 24 hour period.

**Fermentation** - Measure the temperature of grass silage or a compost heap.

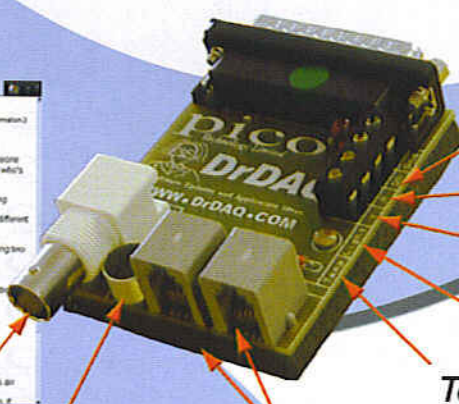
**Fruit Ripening** - Measure the temperature of fruit and electrodes.

**Chemical Reactions** - Experiment with different fuels and electrodes.

**Light level** - Use a photo-diode to view the spectrum.

**Temperature** - Measure the temperature of different materials. Compare wet and dry insulation.

**Temperature** - Measure the effect of warming fluid in bottles using a lamp. One contains air, the other water.



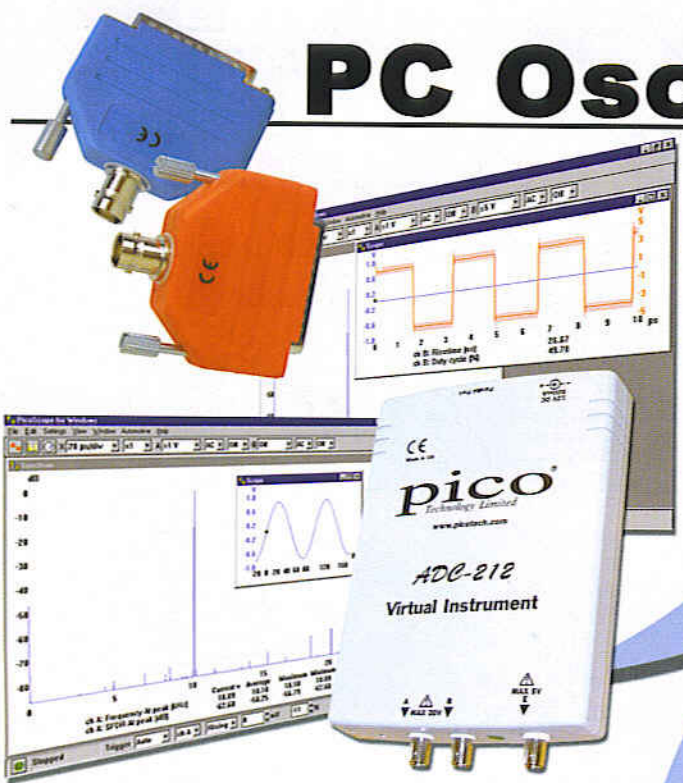
- Output
- Resistance
- Voltage
- Light level
- Temperature
- pH
- Microphone
- External sensors: Humidity
- Temperature
- O2 In Air
- Reed Switch

- Low cost - under £60
- Built in sensors for light, temperature and sound (level and waveforms)
- Use DrDAQ to capture fast signals
- Outputs for control experiments
- Supplied with both PicoScope (oscilloscope) and PicoLog (data logging) software

For more information on DrDAQ, please visit:

[www.picotech.com/drdaq115](http://www.picotech.com/drdaq115)

## PC Oscilloscopes



- Scope and spectrum analyser functions
- A fraction of the cost of benchtop scope
- Save multiple setups, for ease of use
- Save, print and e-mail your traces
- FREE technical support for life
- FREE software and upgrades
- Automated measurements

For more information on our scopes, please visit:

[www.picotech.com/scope252](http://www.picotech.com/scope252)

Tel: 01480 396395 Fax: 01480 396296 E-mail: [sales@picotech.com](mailto:sales@picotech.com)

**PICO**  
Technology Limited

## MEETING

Try to picture for yourself the bi-weekly general editorial meeting of this wonderful magazine, with its inherently international character. Everyone is there: France, England, Germany and the Netherlands, all seated around a large rectangular table structure. And in no particular order, of course. The lab is also present in full strength. Everyone at the table has at least a masters in engineering. And then there's me, with a degree in 17<sup>th</sup>-century Dutch Literature from the University of Nijmegen (1978), chairing the meeting. I hardly need say that the risk of a Babylonian confusion of tongues is all too real. And I can assure you that there are quite a few different 'right answers' to electronic questions. Of course, I try to avoid all of this by holding the floor myself as much as possible. After all, I'm the boss. But you can't keep the tension up all the time, so I like to relax the atmosphere by raising the discussion to a metaphysical level. For example, I might ask, 'Is there really any difference between transistors and valves?', and then pour myself a cup of coffee – since nobody else does that for me, even though I'm the International Editor. And of course I know perfectly well that I'm not supposed to ask such questions, since the editorial staff is officially neutral. Out of the corner of my eye I see one of the designers involuntarily cross his arms: body language for 'I'm taking a stand'. On the other side, 'ze outprint' of a text generated by one of our worthy employees is being vigorously shoved back and forth: body language for 'we don't agree on this'. Every once in a while I have to nudge things along a bit: 'Well, just say what you think!' (and hey presto see pages 25–27 in this very issue).

Sometimes I manage to finish a whole cup of coffee before making another meaningful contribution to the discussion. 'What matters here isn't technology or sound, but music. I still have the old vinyl LPs from Skip James and Jimmy Reed that I played on my very first turntable, when I had to put a heavy coin on the arm to get any sort of sound. And my son uses an MP3 player to listen to his music.'

I can feel a shudder pass through the ranks of the audiophiles at the mention of the word 'MP3'. It reminds me of the official introduction of the CompactDisc (CD – Ed.), when a few fellow journalists asked the Philips press spokesman how Philips had the nerve to be responsible for eliminating everything below 10 Hertz and above 20,000 Hertz from the musical experience of audio enthusiasts. And they got an answer!

In the resulting discussion, someone is bound to come up with the idea of seeing where things stand with the development of techniques to combat noise with sound.

As I always say, a magazine like this puts itself together.

**Mat Heffels, International Editor**



Volume 31, Number 341, March 2005

ISSN 0268/4519

**Elektor Electronics aims at inspiring people to master electronics at any personal level by presenting construction projects and spotting developments in electronics and information technology.**

Elektor Electronics is produced and published by Elektor Electronics (Publishing), P.O. Box 190, Tunbridge Wells TN5 7WY, England. Tel.: (+44) (0)1580 200657, fax: (+44) (0)1580 200616. Email: [sales@elektor-electronics.co.uk](mailto:sales@elektor-electronics.co.uk).

The magazine is available from newsagents, bookshops and electronics retail outlets, or on subscription.

Elektor Electronics is published 11 times a year with a double issue for July & August.

Under the name *Elektor* and *Elektuur*, the magazine is also published in French, German and Dutch. Together with franchised editions the magazine is on circulation in more than 50 countries.

**International Editor:** Mat Heffels ([m.heffels@segment.nl](mailto:m.heffels@segment.nl))

**Editor:** Jan Buiting ([editor@elektor-electronics.co.uk](mailto:editor@elektor-electronics.co.uk))

**International editorial staff:** Harry Baggen, David Daamen, Rolf Gerstendorf, Ernst Krempelsauer, Guy Raedersdorf.

**Design staff:** Karel Walraven (head of design), Ton Giesberts, Paul Goossens, Luc Lemmens ([techdept@segment.nl](mailto:techdept@segment.nl))

**Editorial secretariat:** Hedwig Hennekens ([secretariaat@segment.nl](mailto:secretariaat@segment.nl))

**Graphic design / DTP:** Ton Gulkers, Giel Dols

**Managing Director / Publisher:** Paul Snackers

**Circulation Control:** Margriet Debeij ([m.debeij@segment.nl](mailto:m.debeij@segment.nl))

### Subscriptions

Worldwide Subscription Service Ltd., Unit 4, Gibbs Reed Farm, Pashley Road, Ticehurst TN5 7HE, England. Telephone: (+44) (0)1580 200657, Fax: (+44) (0)1580 200616. Email: [wvss@wvss.demon.co.uk](mailto:wvss@wvss.demon.co.uk). Rates and terms are given on the Subscription Order Form.

### Head Office

Segment b.v. P.O. Box 75 NL-6190-AB Beek The Netherlands. Telephone: (+31) 46 4389444, Fax: (+31) 46 4370161

**Distribution:** Seymour, 86 Newman Street, London W1P 3LD, England

### UK Advertising

Huson International Media, Cambridge House, Gogmore Lane, Chertsey, Surrey KT16 9AP, England. Telephone: +44 (0)1932 564999, Fax: +44 (0)1932 564998. Email: [gerryrb@husonmedia.com](mailto:gerryrb@husonmedia.com). Internet: [www.husonmedia.com](http://www.husonmedia.com). Advertising rates and terms available on request.

### International Advertising

Klaas Caldenhoven, address as Head Office. Email: [advertenties@elektuur.nl](mailto:advertenties@elektuur.nl). Advertising rates and terms available on request.

### Copyright Notice

The circuits described in this magazine are for domestic use only. All drawings, photographs, printed circuit board layouts, programmed integrated circuits, disks, CD-ROMs, software carriers and article texts published in our books and magazines (other than third-party advertisements) are copyright Segment, b.v. and may not be reproduced or transmitted in any form or by any means, including photocopying, scanning or recording, in whole or in part without prior written permission from the Publishers. Such written permission must also be obtained before any part of this publication is stored in a retrieval system of any nature.

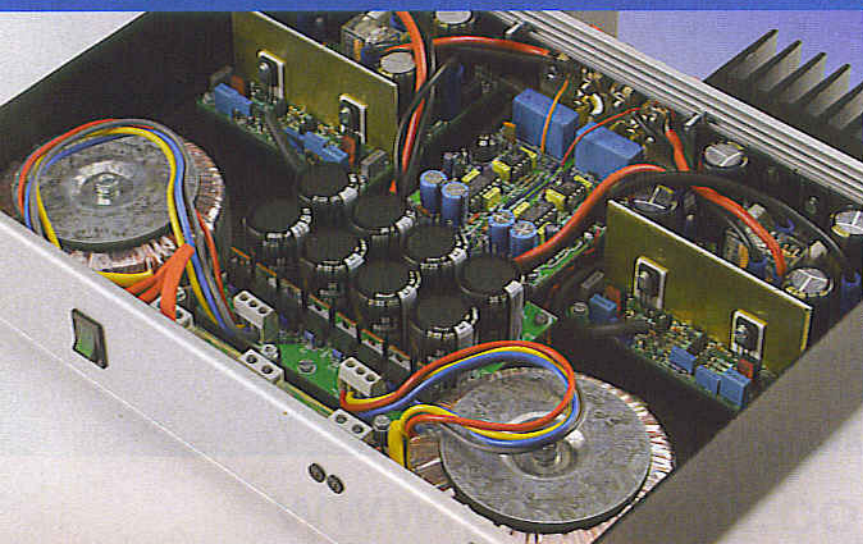
Patent protection may exist in respect of circuits, devices, components etc. described in this magazine. The Publisher does not accept responsibility for failing to identify such patent(s) or other protection.

The submission of designs or articles implies permission to the Publishers to alter the text and design, and to use the contents in other Segment publications and activities. The Publishers cannot guarantee to return any material submitted to them.

© Segment b.v. 2005

Printed in the Netherlands

12



### High-End Power Amp

The High-End Preamp preamplifier published in the April & May 2004 issues naturally calls for a matching final amplifier in an identical housing. The sonic quality of the High-End Power Amp described in this article is outstanding, and its power output more than adequate for filling an average living room with an impressive sound image.

28



### EL156 Audio Power Amplifier

Thanks to its robustness, Telefunken's legendary EL156 audio power pentode has found its way into many professional amplifier units. Its attraction derives not just from its appealing shape, but also from its impressive audio characteristics. We therefore bring you this classical circuit, updated using high-quality modern components.

## Informative Articles

- 25 Opinions on Valves
- 38 Anti-Noise
- 52 Delphi for Electronic Engineers (3)
- 62 Altium FPGA LiveDesign Kit (review)
- 70 E-Online: Audio Tweaks
- 77 retronics: Edwin Audio Amplifier (1975)

## Regulars

- 5 Foreword & Colophon
- 8 Mailbox
- 44 News & New Products
- 78 Quizz'away
- 82 Readers Services
- 84 Sneak Preview
- 84 Index of Advertisers

# CONTENTS

Volume 31  
March 2005  
no. 341

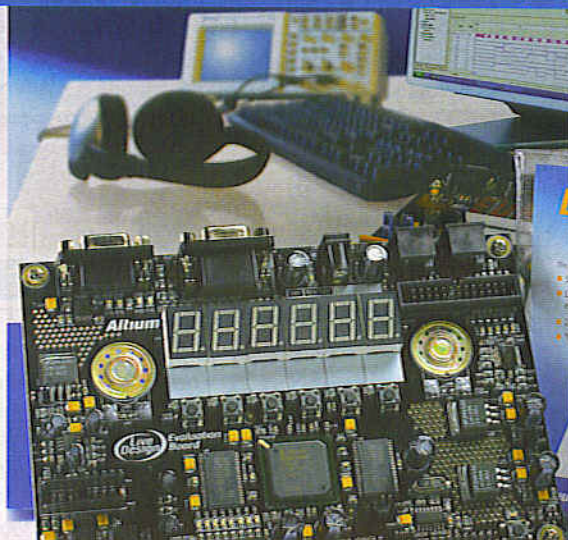
38



## Anti-Noise

Noise has a serious impact on the environment as well as on human beings. Besides classical sound reduction techniques such as insulation, researchers are trying to attack the root of the problem using electronic means. They have already had some success.

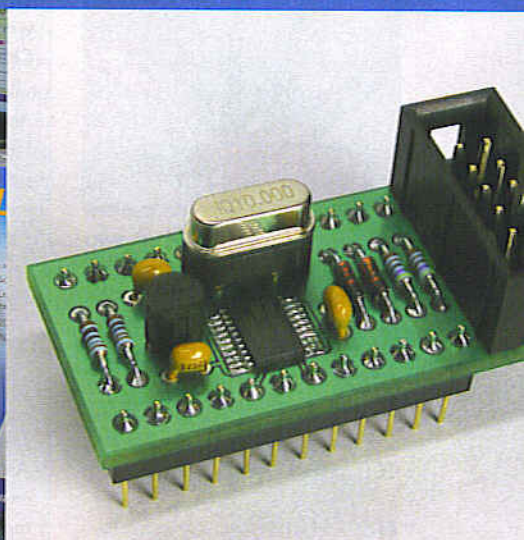
62



## Altium FPGA LiveDesign Kit

Modern circuits make ever more extensive use of FPGAs. Special software is required when designing with these devices. One of the companies that produces such software is Altium, who offer a cheap evaluation kit. Once the evaluation period has expired, the kit is still very useful as a development platform for your own designs!

66



## Serially Programmable Crystal Oscillator

The right crystal controlled frequency at the right time: With this DIP outline oscillator there's no need to wait for a special crystal to be made up. You can program its frequency precisely using the RS232 port of your PC. Low phase noise is a feature that makes this PLL oscillator suitable for demanding RF applications also.

## Construction Projects

- 12 High-End Power Amp
- 28 EL156 Audio Power Amplifier
- 42 Remote Temperature Logger for PIC18F Board
- 46 LPC210x 'ARMee' Development Board (1)
- 56 Play Solitaire
- 66 Serially Programmable Crystal Oscillator
- 73 start here: Bidirectional S/PDIF Converter
- 74 kitchen table: Opamp Tester

### web technology allowing...

our completely restyled website should be online by mid-February 2005. New features include Forum, Marketplace, News Service, Online Shop, secure payment options, article downloads.... check it out!

### Elektor on CD-ROM

Volume 2004 now available

**Swiss Army Knife update**



Jim Spence kindly informed that a software update is available for his Swiss Army Knife project (Elektor Electronics September 2004).

There is a new version of TCB (TB-2-K), which enhances the existing TCB as follows:

**New comment symbol,** allows source code to be commented without being stored.

**Better error handling,** indication line number where error occurred.

**Hex** - handling of hex numbers improved, numbers can now be either decimal or hex without changing the operating mode. Example, a=&FE.

**LOADB** - massive time saving feature, LOADB will now load a TCB program with or without line numbers.

**I2C** - Full support for I<sup>2</sup>C devices using software, no special processor needed, new I<sup>2</sup>C commands: CPOKE, CPEEK, CPUT, CGET, CREAD & CWRITE.

**24LC256** - EEPROM support (LOAD & SAVE), enables programs to be saved and loaded thus eliminating the need for a battery backed RAM.

**RUN** - extended to allow running programs in RAM space, when called from ROM space

**TV Commercials Killer**

Dear Editor — your article on the 'TV Commercials Killer' (July/August 2004) was a very practical application. The problem with it, is that in my country, South Africa, the logo is usually at the bottom section of the screen. Is there any way of making it work for me? Maybe some hints on software modification. Thank you for such a great magazine.

**Charl Roux (South Africa)**



The same question has been asked by a number of other readers. As stated at the end of the article, the project was not tested or post-engineered by our in-house design staff. The author's contact details may be found at the end of the parts list on page 27. Hopefully Mr. Schulze is able to help.

There is also a version that will work on the Elektor Electronics 'Flash Microcontroller Starter Kit' — the same as above but with automatic RAM detection switched off.

The updates may be obtained from our website, see September 2004 items.

**Clarity Class-T amplifier**

Dear Jan — as you know we are selling kits of the Clarity Class-T Amplifier project (June, September, October 2004; Ed.).

Unfortunately we ran into supply problems with the STW38NB20 component, ST having advised us that it

is no longer manufactured and available to the retail trade. Can you suggest an alternative?

**Peter Geist (Geist Electronic, Germany)**

Ton Giesberts, our audio designer replies: a possible alternative is IRF's type IRF41N15D, however, it is housed in a TO220AB case! A quick comparison shows:

| Parameter            | IRF   | ST    | Unit      |
|----------------------|-------|-------|-----------|
| I <sub>D</sub>       | 41    | 38    | A         |
| R <sub>DS(ON)</sub>  | 0.045 | 0.065 | Ω (max.)  |
| P <sub>tot</sub>     | 200   | 180   | W         |
| C <sub>iss</sub>     | 2520  | 2800  | pF (typ.) |
| T <sub>j</sub>       | 175   | 150   | °C        |
| R <sub>th(j-c)</sub> | 0.75  | 0.69  | °C/W      |
| Q <sub>G</sub>       | 72    | 70    | nC        |
| U <sub>DS</sub>      | 150   | 200   | V         |

The lower value for U<sub>DS</sub> is not a problem, the supply voltage being smaller than 120 V<sub>pp</sub>. Tripath also recommend this transistor for use with their TA3020. The replacement has not been tested yet in the Elektor labs.

**Parallel PIC Programmer**

Dear Editor — I would like to inform you about a PIC programmer that's controlled over the parallel printer port and is compatible with Win2000 and XP. It is found at [www.oshonsoft.com](http://www.oshonsoft.com). The signal wires used can be selected by the user.

**H. Sprenger (Germany)**

Thanks for the tip!

**Crescendo ME and electrolytics in storage**

Dear Editor — it is my intention to connect an Elektor Crescendo Millennium Edition ('ME') amplifier into a loud-speaker system with an impedance of about 2.5 ohms. Can you please

Advertisement

ANDRE LAMOTHE'S  
**XGAMESTATION**  
LEARN STEP-BY-STEP HOW TO BUILD AND DESIGN YOUR OWN VIDEO GAME CONSOLE!

Design inspired by the Atari 800/2600, Sinclair ZX Spectrum, Apple II & Commodore 64!

Parallax SX-Key Compatible!

**INCLUDES:**

- Tools, Demos & Utilities!
- Great for Hobbyists AND Students!
- The Fun Way to Learn Embedded Systems!
- Fully Assembled XGS Micro Edition Unit!
- Complete Software Development Kit!
- eBook on Designing the XGS Console!
- Cables and Power Supply Included!

WWW.XGAMESTATION.COM  
PH: 925.736-2098 | SUPPORT@NURVE.NET

NURVE NETWORKS LLC  
4525 DANFORTH AVENUE  
DANVILLE, CA 94506 USA



advise if that is possible without alterations to the amplifier electronics?

Also, I have available a quantity of Philips 10 mF/63 V electrolytic capacitors that have been in storage for about 10 years (I think!). Can I use these components; it is possible to regenerate them, or should I bin them? Is there a way to extract the manufacturing date from the print on these devices?

**C. Krampe-Zadler (Germany)**

*In theory, the lower impedance is just about acceptable if you assume that the amplifier does not supply more than 30 V at 2.5 A (i.e., 12 amps maximum). It is therefore recommended to employ a mains transformer with a slightly lower secondary voltage.*

*Regarding your second question, having been in storage for such a long time, the electrolytics are probably in need of being regenerated. This is best done by applying the maximum device voltage (63 volts) via a 1-megohm resistor for some time, observing all relevant safety precautions. In all probability, these devices will be usable. The manufacturing date can be gleaned from the date code (DIN 41314 / IEC 60062), as follows:*

| Year Code | Month Code   |
|-----------|--------------|
| 1995 = F  | January = 1  |
| 1996 = H  | February = 2 |
| 1997 = J  | March = 3    |
| 1998 = K  | April = 4    |
| 1999 = L  | May = 5      |
| 2000 = M  | June = 6     |

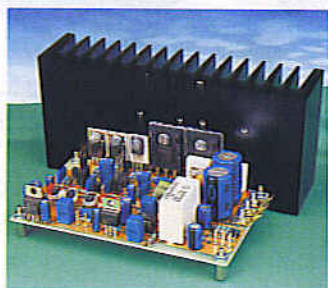
|          |               |
|----------|---------------|
| 2001 = N | July = 7      |
| 2002 = P | August = 8    |
| 2003 = R | September = 9 |
| 2004 = S | October = 10  |
| 2005 = T | November = 11 |
| 2006 = U | December = 12 |
| 2007 = V |               |
| 2008 = W |               |

*For example, a capacitor marked 'L6' was manufactured in June 1999.*

### OP-77 Replacement

Dear Jan — I'm sorry the project I need to ask assistance with is a bit aged ('Compact AF Power Amplifier', *EE* May 1997). The problem is that the guy at my local electronics shop tells me the OP-77 opamp is no longer available, suggesting the LM301AP as an alternative. Can you confirm this, please, or are there better alternatives? I also wonder if I can use the value 330 Ω for R8 and R9, instead of the specified 340 Ω which I am unable to obtain at such small quantities.

**E. Oeynhausen (Germany)**



*The OP-77 may be replaced by any low-offset opamp, which positively excludes the LM301! Also, be sure to select a type that's suitable for operation at a supply voltage of ±18 V. An excellent replacement for the venerable OP-77 is the OP177GP from Analog Devices, which is no coincidence as it is actually an*

*improved OP-77. Another suggestion is the OPA177GP from Texas Instruments (listed by, among others, Farnell).*

*If at all possible you should stick to the specified 340 ohms for R8 and R9. With due regard to tolerance issues, the required value may be obtained by paralleling resistors from the E24 series, or in really acute cases, the E12 series (do check the end result with an accurate ohmmeter); for example, 360 Ω//6kΩ2 or 390 Ω//2kΩ7.*

### Cleaning the Mains

Dear Editor — I am looking for a circuit diagram of a good mains filter. Did you ever publish such a design and if so, when?

**Jan Verbeeck (Netherlands)**

It may not be obvious from the article title, but an excellent mains filter for home construction is included in 'Noise Suppression Filters' published in the November 2004 issue of *Elektor Electronics*. This article was the concluding part of our Clarity 2x300-watt audio amplifier. Mains filters must be built, installed and used in compliance with relevant safety guidelines.

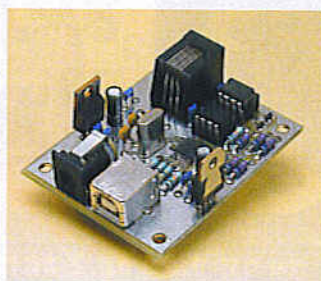
### USB/I<sup>2</sup>C Interface (1)

Dear Jan — Having read your article in the December 2004 issue, I can not find conclusive evidence that the circuit, apart from its normal function, is also suitable for reading data on the I<sup>2</sup>C bus, without omitting the P82B715PN component.

My uncertainty is probably caused by the circuit symbol used for the component in the various drawings, and the

fact that the examples only mention driving the outputs.  
**Manuel Friedmann (Germany)**

*Even if the circuit diagram does not show it explicitly, the P82B715PN is a bidirectional component (see [www.semiconductors.philips.com/pip/P82B715PN.html](http://www.semiconductors.philips.com/pip/P82B715PN.html)). Consequently, nothing changes when compared to the circuit without the P82B715PN. Incidentally, controlling devices over the I<sup>2</sup>C bus always requires a bidirectional interface. Also see 'Corrections & Updates', February 2005.*

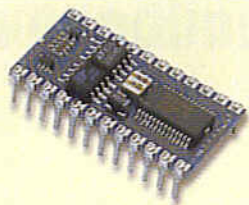


### MailBox Terms

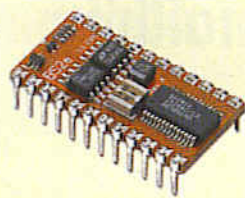
- Publication of reader's correspondence is at the discretion of the Editor.
- Viewpoints expressed by correspondents are not necessarily those of the Editor or Publisher.
- Correspondence may be translated or edited for length, clarity and style.
- When replying to MailBox correspondence, please quote Issue number.
- Please send your MailBox correspondence to: [editor@elektor-electronics.co.uk](mailto:editor@elektor-electronics.co.uk) or Elektor Electronics, The Editor, P.O. Box 190, Tunbridge Wells TN5 7WY, England.



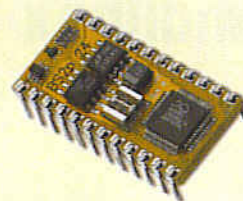
BS2-IC



BS2-SX



BS2E-IC

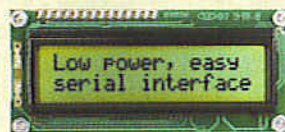


BS2P/24



BS2P/40

**Parallax BASIC Stamps - still the easy way to get your project up and running!**



**Serial Alphanumeric and Graphic Displays,  
Mini-Terminals and Bezel kits**

[www.milinst.com](http://www.milinst.com)



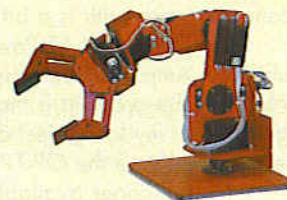
Animated Head



3-Axis Machine



Six-Legged Walkers

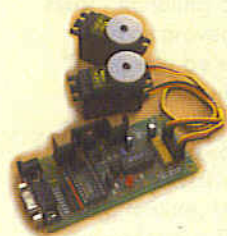


Robotic Arms

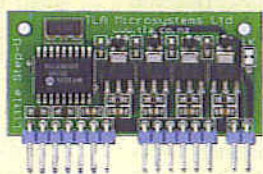


Bipeds

**Robotic models for both the beginner and the advanced hobbyist**



Servo Drivers



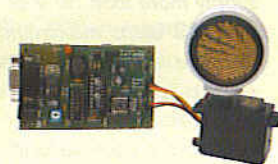
Motor Drivers



On-Screen Displays



DMX Protocol



U/Sound Ranging

**Animatronics and Specialist Interface-Control Modules**



Quadravox  
MP3 & Speech Systems



SensoryInc  
Voice Recognition



Parallax  
Ubicom Tool Kits



Tech-Tools  
PIC & Rom Emulators



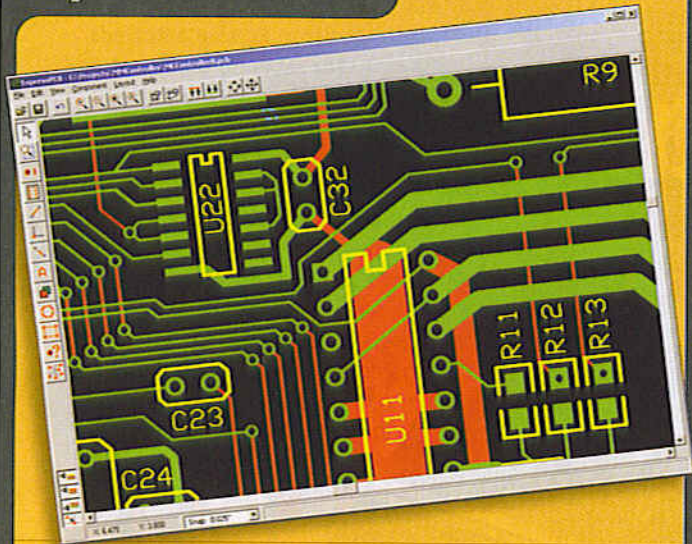
BASICMicro  
PIC BASIC Compilers

**Development Tools**

# FREE

## Layout Software

**EASY** To Use!  
Very **LOW** Cost!  
Extremely **FAST**  
Turnaround!



- 01 **DOWNLOAD** our free CAD software
- 02 **DESIGN** your two or four layer PC boards
- 03 **SEND** us your design with just a click
- 04 **RECEIVE** top quality boards in just days

[expresspcb.com](http://expresspcb.com)

# WebBrick

## Web-enabled Building Automation control unit

- ✓ Process control device with 8 states machines
- ✓ Network interface & web browser configuration panels
- ✓ 8 configurable trigger inputs
- ✓ 12 TTL digital inputs
- ✓ 8 TTL & O.C digital outputs
- ✓ 1 Temperature sensor input
- ✓ 1 Rotary encoder input
- ✓ 2 Analogue outputs
- ✓ 1 Analogue input



Proven technology  
Reliable / Robust  
User Configurable  
Python/PHP Scripts  
Web Browser Panels  
SMS Integration

£129.95 + Package  
/ Postage / VAT

Go to: [www.o2m8.com/elektor](http://www.o2m8.com/elektor)

Welcome lighting  
House minding  
Secure homes

# O2M8

local control - global intelligence

Energy saving  
Aquarium control  
Security cameras

O2M8 Ltd, Unit 10, Brewery Court, Theale, Berkshire, RG7 5AH  
Telephone: 01189 830832 Fax: 01189 830831  
[info@o2m8.com](mailto:info@o2m8.com) [www.o2m8.com](http://www.o2m8.com)

# PCB-POOL®

SERVICING YOUR COMPLETE PROTOTYPE NEEDS

- Prototypes at a fraction of the cost
- Tooling and setup included
- Any contour
- Fr4 1.6mm, 35µm Cu
- Industry standard quality
- Follow up series runs
- CAM / CAD consulting

PRICE EXAMPLE:  
**1 EUROCARD DS/PTH**  
+ Tooling  
+ Photoplots  
+ VAT  
= £ 29.89\*

\*Sterling rates may vary. Price = € 49

# €49



**FREE**

with first order  
(while stocks last)

may differ slightly  
to actual prices

**Beta**  
CIRCUIT

Tel: +353 (0)161 701170  
Fax: +353 (0)161 701164  
E-Mail: [sales@beta-circuit.com](mailto:sales@beta-circuit.com)

Freephone  
**0800-389 8560**

Simply send your files and order ONLINE:

# WWW.PCB-POOL.COM

VARSET Protel orcad GraphiCode PROTELS Electronics

**Are you passionate about your electronics?**  
**Do you love building kit, and making things work?**  
**Do you want to build a career, getting paid for doing what you enjoy?**

Yes to all of these? Then plug into your potential - launch or upgrade your qualifications in Electronics, by studying at Derby

## BSc Electronics

**BSc Electrical & Electronic Engineering**  
**Also Foundation Year, and HNC/HND**  
**Electrical & Electronic Engineering**

- For people who love electronics, taught by people who love electronics
- Part-time and full-time study modes available
- Ideal both for the school leaver, and the mature learner
- Easy upgrades from HNC to HND to BSc (Honours)
- Final Year options give specialist training in current hot topics, like digital signal processing, embedded systems, EMC, or power electronics

For further details view <http://vertigo.derby.ac.uk/> and email or phone: Dr Amar Bousbaine, [a.bousbaine@derby.ac.uk](mailto:a.bousbaine@derby.ac.uk) tel: 01332 591760 OR Tim Wilmshurst: [t.j.wilmshurst@derby.ac.uk](mailto:t.j.wilmshurst@derby.ac.uk) tel: 01332 591350, University of Derby, Kedleston Road, Derby. DE22 1GB. UK

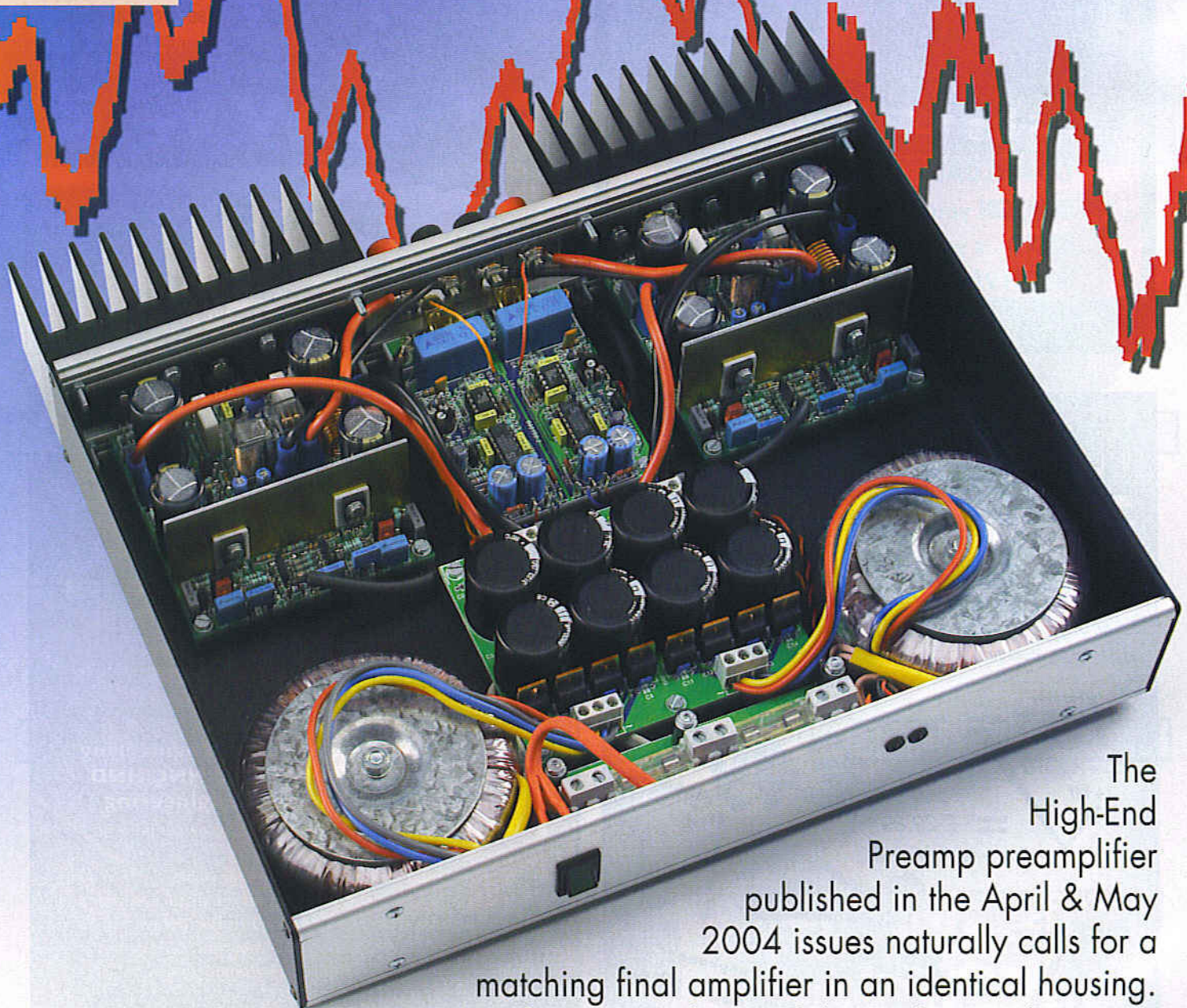
plug in:  
to your potential

UNIVERSITY  
of DERBY

# HIGH-END POWER AMP

## High-class watts

Ton Giesberts



The High-End Preamp preamplifier published in the April & May 2004 issues naturally calls for a matching final amplifier in an identical housing. Due to the restricted size of the enclosure, the output power of this final amplifier is somewhat on the modest side, but the quality is outstanding – and it is more than adequate for filling an average living room with an impressive sound image.

The Audio Link amplifier, published a year ago, was well received by audio enthusiasts due to its very convenient user interface and high-quality, no-nonsense signal processing. A matching final amplifier must naturally have the same level of quality, and here we have made an extra effort to achieve this result. Our desire to use an identical enclosure meant that there wasn't all that much space available, and the maximum output power of a final amplifier largely depends on its size. The dimensions of the heat sinks and transformers are particularly restricted by the size of the enclosure. We managed to achieve a bit less than 50 watts into 4 ohms, using 80-VA toroidal transformers.

This amplifier is thus primarily suitable for people who like to listen to music at a 'civilised' volume and are very demanding with regard to reproduction quality.

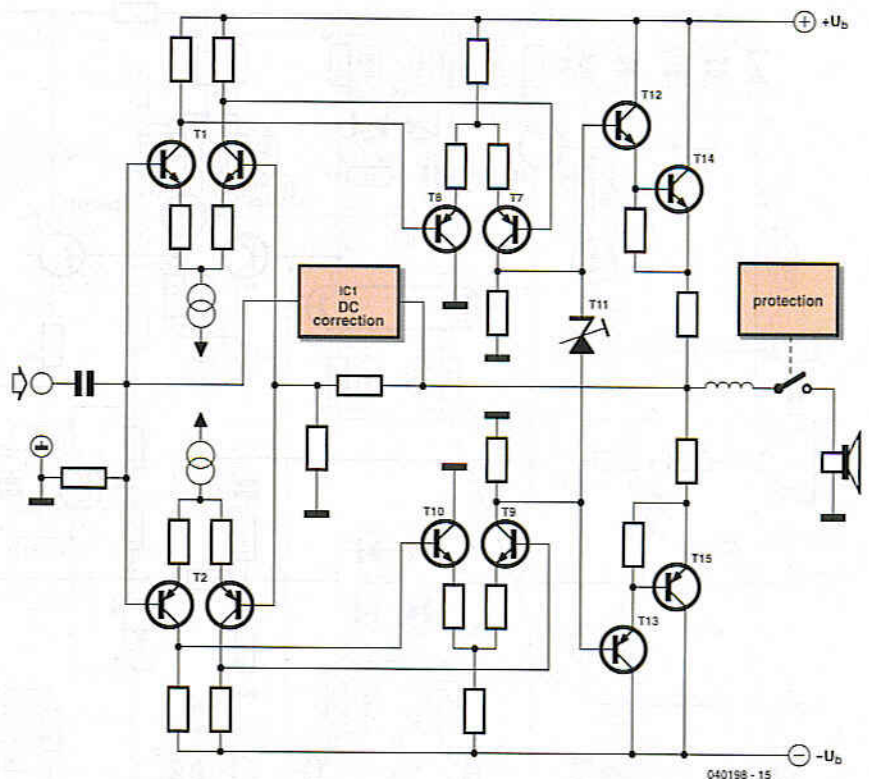
As the output power is distinctly less than what many of our previous (discrete) final amplifiers can provide, we added an accurate overdrive indicator to this design. It compares the input and output signals of the final amplifier and lights up an LED if the difference is too large. This enables the listener to keep a good eye on the output drive level.

## Output stage

Readers who have paid attention to the schematic diagrams of our final amplifiers during recent years will see a lot of familiar features in the present design. There aren't any real surprises, and the sound quality is determined more by the choice of transistors and the circuit board layout than by the circuit design.

As you can see from the block diagram in **Figure 1**, each channel of the amplifier essentially consists of two differential amplifiers and an emitter follower, but with a fully symmetrical design. There is also an integrator that eliminates any DC offset voltage at the output.

The input stage differential amplifier (**Figure 2**) consists of two complementary dual transistors (T1a/T1b and T2a/T2b) from Toshiba. It is followed by a second set of differential amplifiers (T7/T8 and T9/T10), which provide most of the gain. The combination of T7 and T9 also forms a push-pull amplifier that can supply more than enough current to drive the emitter-follower output stage. The operating points of these differential amplifiers



**Figure 1.** Block diagram of the High-End Power Amplifier, which is based on previous Elektor Electronics designs.

are determined entirely by the operating points of T1 and T2. The currents through the differential transistors in the second stage of the amplifier are determined by R20–R22 or R23–R25 and the voltage across R7/R8 or R10/R11, respectively. The voltages across the collector resistors of the input pairs are in turn determined by constant-current sources T3 and T4.

As can clearly be seen, all of the operating points in the amplifier are directly dependent on these two current sources, so we gave particular attention to their design. The reference voltages for the current sources are provided by flat LEDs, which in turn are operated at reasonably constant currents provided by a pair of simple JFET current sources. As a result, the current sources built around T3 and T4 are practically immune to power-supply ripple and supply voltage fluctuations. Unfortunately, JFETs have a rather large tolerance range, so you should measure the voltages at the points shown on the schematic diagram and compare them with the indicated values. A deviation of more than 20% is not acceptable.

The power output stages are wired as emitter followers using a standard design with two complementary sets

of transistors in Darlington configuration (T12/T14 and T13/T15). Resistors R26 and R27 are placed at the inputs of the emitter followers to linearise the input impedance of the current amplification stage and reduce the effects of various parasitic capacitances. Although this reduces the open-loop gain, it also considerably increases the bandwidth. This allows less negative feedback to be used, which from an audiophile perspective can be regarded as better for reproduction quality.

T11 is used to set the quiescent current. Here we use the same type of transistor as the NPN driver (T12). This makes assembly easier because these transistors have a plastic package that can be fitted to the heat sink without using an insulator, which is also true of T13. The quiescent current bias transistor is located on the circuit board between the two output-stage transistors (T14 and T15), which do have to be fitted with mica insulating washers, in order to achieve maximum thermal coupling. Driver transistors T12 and T13 are located on either side of this set of three transistors. The quiescent current of the output transistors is set to 100 mA, which is sufficient.

Integrator IC1 compensates for the input bias current, as well as any off-

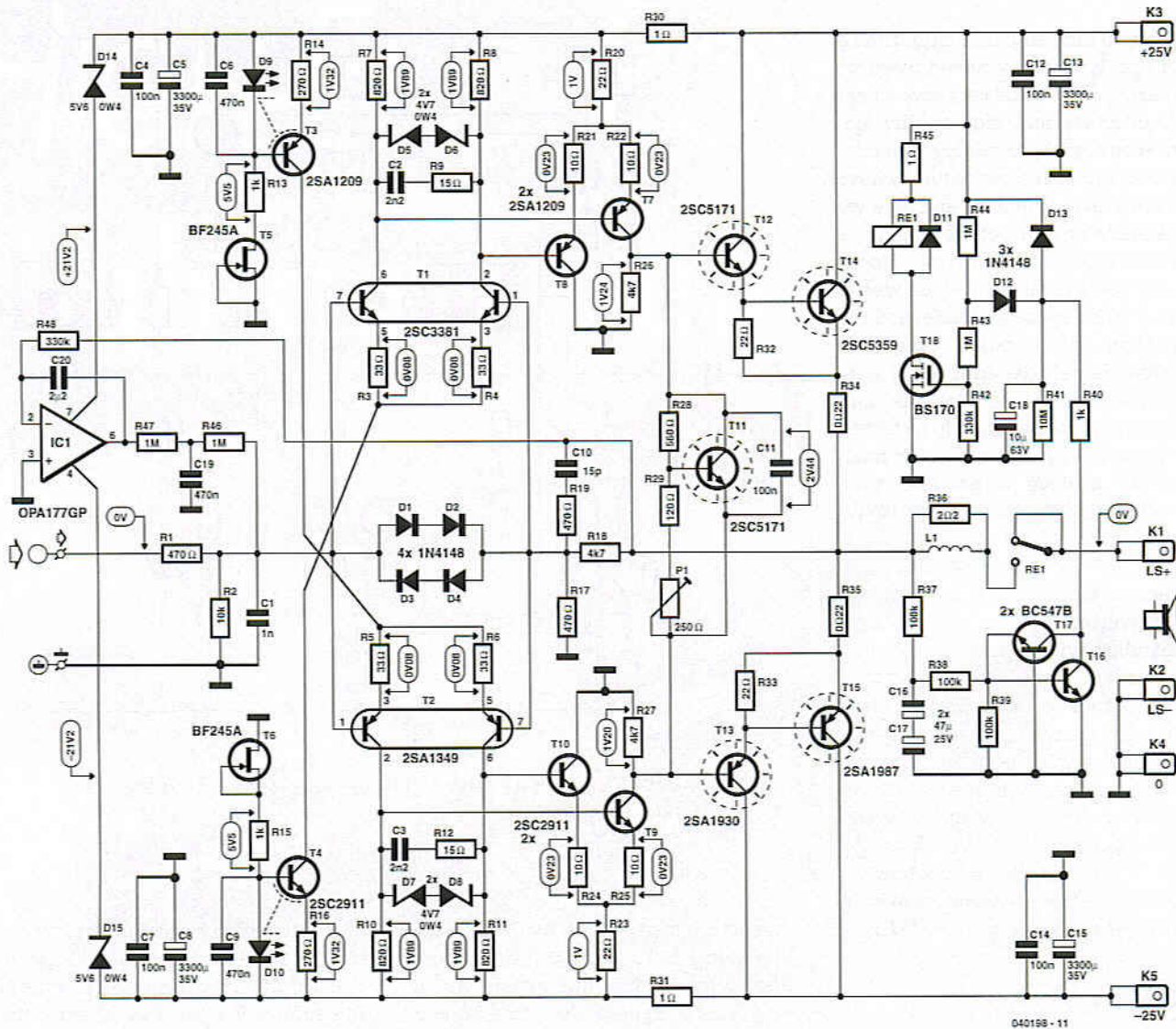


Figure 2. Careful component selection enables this design to achieve significantly better results than previous models.

sets that may arise due to inequalities in the various DC settings, by injecting a current into the input of the amplifier. The bias current is primarily due to differences in the amplification factors of the complementary dual transistors and the currents from the two current sources, as well as imbalances in the transistors of the following stages (differences in amplification factors and base-emitter voltages). A bias current of approximately 8  $\mu\text{A}$  can be compensated using the indicated component values. R48 and C20 determine the integration time constant, and C19 decouples any effects from IC1 (except for bias current correction). R1 and C1 at the input of the amplifier form a low-pass filter that prevents the amplifier from being overdriven if excessively steep signal edges are present at the input. To keep the resulting offset voltage small, input resistor

R2 has a lower value than usual (10 k $\Omega$  in this case). The input sensitivity of this final amplifier has also been made relatively low to reduce the likelihood of overdriving. Its gain is thus set to approximately 10.5 using R17 and R18 (but don't forget the effect of R1).

For IC1 to do its job properly, the input must be AC coupled. With the value chosen for the input resistor, the capacitance necessary to yield a sufficiently low roll-off frequency can only be provided by a capacitor with rather large dimensions, so we decided to put it on the printed circuit board for the overdrive indicator circuit. That allows the circuit board for the final amplifier to remain relatively small and increases the distance between the mains transformers and the amplifier circuit board. An additional benefit is that the overdrive indicator can directly access the input

signal after the input capacitor, which eliminates the need for an extra tap. The frequency compensation for the amplifier, which largely determines its open-loop characteristics, is provided by C2/R9 and C3/R12. HF decoupling is provided by the C10/R19 network. The amplifier output is switched by a 16-A relay. The type specified in the components list has an industry-standard pinout and can be replaced by other equivalent types.

To protect the loudspeakers against output offset voltage transients that may occur when the mains voltage is switched on, a switch-on delay is provided for the output relay. The delay time is approximately 6–7 seconds. The state of the relay depends on the supply voltage for the final amplifier, rather than the transformer voltage. If the supply voltage drops below 17 V, MOSFET T18 de-energises the relay.

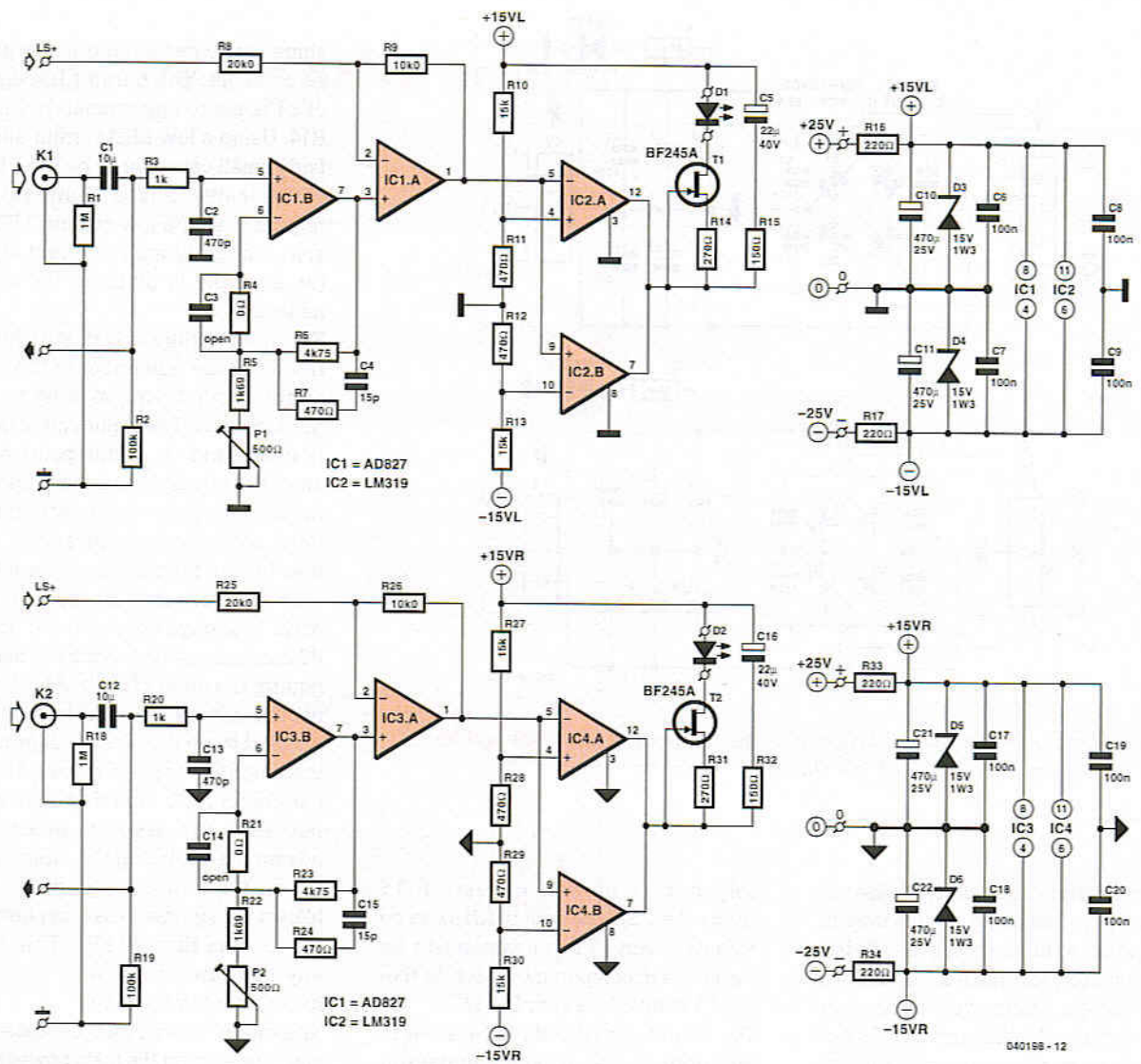


Figure 3. The stereo overdrive indicator constantly compares the input and output signals of the final amplifier and shows whether the difference is too large. The input capacitors for the amplifier boards are also located here.

The MOSFET starts to conduct when its gate voltage is approximately 2.5 V. The threshold value can vary from one FET to the next, so the delay time can also vary. The gate is connected directly to the supply voltage via voltage divider R42–R44. Diode D12 prevents C18 from holding the MOSFET in the 'on' state when the supply voltage drops, and D13 ensures that C18 discharges if the supply voltage drops below half its normal value. This avoids excessive reduction in the delay time if the amplifier is switched on too quickly after being switched off.

The relay coil is connected to the supply voltage via R45, so a relay with a lower coil voltage can be used by changing the value of R45. Be sure to use a resistor with an adequate power rating.

The DC protection circuit is also coupled to the switch-on delay circuit. It

de-energises the relay by quickly discharging C18 in the switch-on delay circuit. If a positive DC voltage is present, T16 will conduct and discharge capacitor C18 via R40 if the voltage at the amplifier output is greater than +1.5 V. If an excessively large negative voltage is present at the output, T17 will conduct due to the negative voltage on its emitter. In this case, the discharge current from C18 must flow through R37 and R38. The resistance values of voltage divider R42–R44 also determines the values of R37–R39. The latter values must be kept relatively low, since otherwise the threshold for detecting a negative DC voltage on the amplifier output would be too great. It is approximately –3.5 V with 100-k $\Omega$  resistors. This means that the circuit is somewhat less sensitive to negative DC voltages than to positive DC voltages, but that does not have any practical consequences.

## Overdrive indicator

As the output power of this amplifier is rather modest by contemporary standards, it's quite possible for it to be overdriven during loud music passages, which will result in clipping. For this reason, a reliable LED indicator circuit has been added to the design to indicate overdrive conditions. The indicator circuit (Figure 3) constantly compares the output signal with the input signal and generates a warning if they do not match. Apart from having greater amplitude, the output signal from the amplifier should have the same phase and frequency characteristics as the input signal.

The signals are compared by attenuating the output signal and amplifying the input signal. The input signal amplifier built around IC1b (or IC3b for the other channel, which is not further described here) simulates the transfer

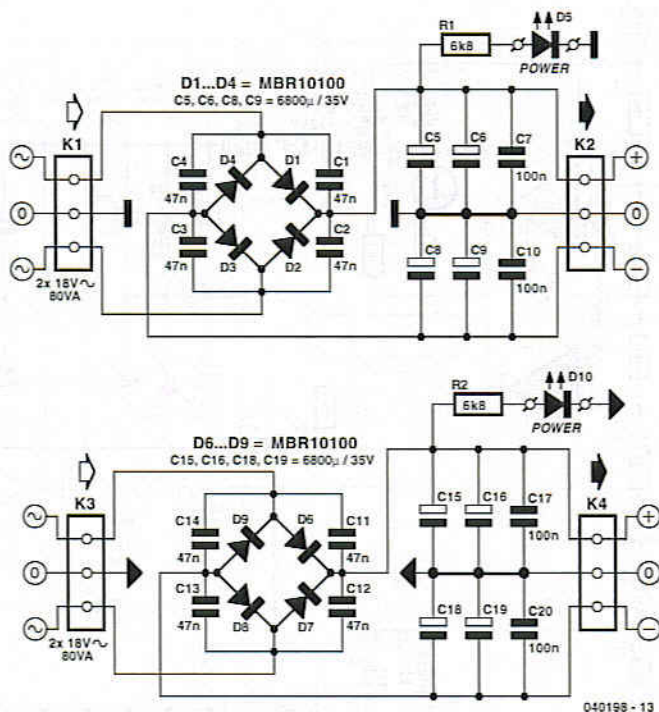


Figure 4. The power supply uses Schottky diodes for low voltage losses and has a buffer capacity of  $2 \times 13,000 \mu\text{F}$  per channel.

characteristics of the final amplifier as well as possible using simple means. For instance, RC network R3/C2 has approximately the same time constant as the low-pass filter at the input of the final amplifier (R1/R2 and C1). R3 and C4 are reserved for unusual input configurations in other applications and are not used here. The network formed by C4 and R7 does not have much effect here, but it is included for the sake of completeness.

IC1 is a fast dual opamp (type AD827). Here IC1a is configured as a difference amplifier that compares the two signals at its inputs. R8 and R9 attenuate the loudspeaker signal by a factor of two ( $10.5 \div 2$ ). This means that IC1b

only has to provide a gain of 3.5 ( $10.5 \div 2 \div 1.5$ ). The gain of IC1a can be adjusted using P1 to compensate for variations in component values. In theory, P1 should be set to  $210 \Omega$ .

The output signal from IC1a is fed to the input of IC2, a dual comparator that is used here as a window comparator. The threshold levels are  $+0.5 \text{ V}$  and  $-0.5 \text{ V}$ , which means that the output voltage must differ from the expected value by more than  $1 \text{ V}$  (10.5 times the input voltage) to generate a warning signal. It hardly needs saying that a large difference is most likely a sign of clipping, which occurs when the amplifier is overdriven. Reducing the threshold levels would excessively increase the sensitivity of the circuit to noise and other forms of HF interference, so the LED would tend to light up before the amplifier was actually being overdriven.

The combined open-collector outputs of the comparators charge capacitor C5. Here R15 provides current limiting. The voltage on C5 is used to cause LED D1 to shine quite visibly even if overdrive only occurs during short peaks. After the comparator outputs have returned to the high-impedance state, the LED will continue to be supplied with current via constant-current source T1. This causes the energy stored in the capacitor to be used as effectively as possible, so the LED will

shine with constant brightness as long as possible. The current through the JFET is set to approximately  $2 \text{ mA}$  by R14. Using a low LED current allows a fairly small capacitor to be used for C5, which saves space. However, this requires using a low-current LED that shines brightly with a current of  $2 \text{ mA}$  (an example is given in the components list).

The input ground is kept strictly separate from the remainder of the circuit on the circuit board, in order to avoid ground loops. The input signal ground is connected to a star point on the amplifier circuit board. The input signal and the ground connection of the input socket on the indicator board go from here to the amplifier board. Resistor R1 ensures that the input terminal of C1 is always connected to ground. R2 is necessary to provide the bias current for the input of IC1b. As R2 is connected in parallel with the input, we decided to tie it to the input ground of the amplifier board. Drawing the bias current for IC1b from that source does not have any negative effects. The advantage of placing the input capacitor on the indicator board is that it allows the signals to be compared from DC to more than  $20 \text{ kHz}$ . This avoids any measurement errors due to the lower roll-off frequency.

The supply voltage for the indicator circuit is taken from the main power supply and stabilised using Zener diodes, since the value is not critical. Allowance has been made for a fairly high load on the supply and associated voltage slumps. For this reason, the Zeners are operated at relatively high currents, which means that the associated series resistors (R16, R17, R33 and R34) must be 1-watt types. To save space, we selected especially small types (Vishay BCcomponents PR01 series).

## Power supply

A separate printed circuit board has been designed for the power supply (Figure 4). It just fits into the enclosure between the transformers. The power supply design is quite conventional, with a standard 80-VA toroidal transformer, rectifier, and electrolytic smoothing capacitors for each channel. To make it easier to connect the transformers, we also designed a separate circuit board with three terminal blocks and two fuses (Figure 5) to allow the primary leads of the two transformers for a stereo amplifier to be properly connected and fitted. The secondary leads

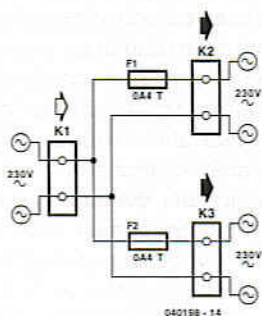


Figure 5. An auxiliary circuit for the mains fuses and some terminal blocks for connecting the transformers and mains switch.

# Measured performance

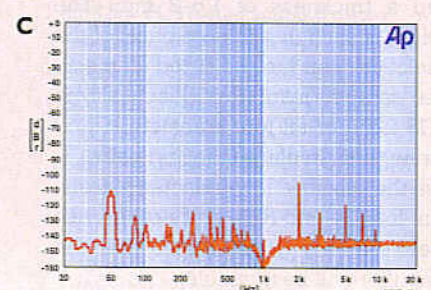
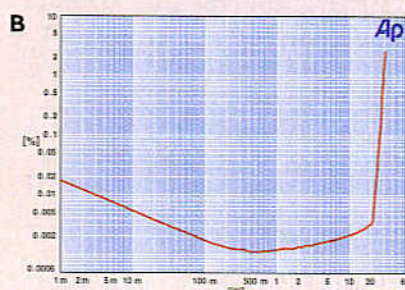
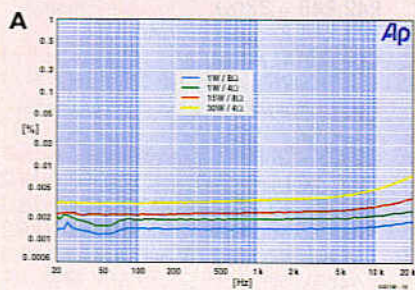
|  |                       |  |                |                |
|--|-----------------------|--|----------------|----------------|
| Input sensitivity  |                       | 1.5 V <sub>eff</sub> (30 W, 8 Ω, 1 % THD+N)<br>1.4 V <sub>eff</sub> (26 W, 8 Ω, 0,1 % THD+N) |                |                |
| Input impedance  |                       | 9.3 kΩ   |                |                |
| Sine-wave power  | (0.1 % THD+N)         | 8 Ω  | 4 Ω            | 2 Ω            |
|  | (1 % THD+N)           | 26 W   | 42 W           | 58 W           |
|  |                       | 30 W   | 47 W           | 65 W           |
| Power bandwidth  | (referred to 1 W/8 Ω) | 1.5 Hz to 265 kHz  |                |                |
| Slew rate  |                       | 18 V/μs  |                |                |
| Rise time  |                       | 2 μs   |                |                |
| Signal to noise ratio  | (referred to 1 W/8 Ω) | 111 dBA  |                |                |
|  |                       | 101 dB (22 Hz to 22 kHz linear)  |                |                |
| Harmonic distortion plus noise<br>(B = 80 kHz)                     | 1 kHz                 | 8 Ω  | 4 Ω            | 2 Ω            |
|  | 1 kHz                 | 0.0014% (1 W)  | 0.0019% (1 W)  | 0.0029% (1 W)  |
|  | 20 kHz                | 0.0024% (15 W)   | 0.0035% (30 W) | 0.0053% (40 W) |
|  |                       | 0.0037% (15 W)   | 0.0075% (30 W) | 0.01% (40 W)   |
| Intermodulation distortion<br>(50 Hz : 7 kHz = 4 : 1)              |                       | 0.0030% (1 W)  | 0.0037% (1 W)  | 0.007% (1 W)   |
|  |                       | 0.0077% (10 W)   | 0.012% (20 W)  | 0.018% (30 W)  |
| Dynamic IM distortion<br>(3.15-kHz square wave + 15-kHz sine wave) |                       | 0.0013% (1 W)  | 0.0013% (1 W)  | 0.0016% (1 W)  |
|  |                       | 0.0010% (15 W)   | 0.0013% (30 W) | 0.002% (40 W)  |
| Damping factor   | 1 kHz/8 Ω             | > 450  |                |                |
|  | 20 kHz/8 Ω            | > 230  |                |                |
| Open-loop parameters (15 W/8 Ω/1 kHz)                              | Gain                  | 2183   |                |                |
|  | Bandwidth             | 55 kHz   |                |                |
|  | Output impedance      | 0.5 Ω  |                |                |
|  | THD+N 1 kHz           | 0.48%  |                |                |
|  | THD+N 20 kHz          | 0.53%  |                |                |
| Overdrive indication<br>(at P <sub>max</sub> )                     | 10 Hz                 | 1.5% THD+N   |                |                |
|  | 1 kHz                 | 1.5% THD+N   |                |                |
|  | 20 kHz                | 0.3% THD+N   |                |                |
| DC protection  |                       | +1.5 V/-3.5 V  |                |                |

Besides these numerical results, we also recorded several plots that give a bit more insight into the quality and character of the amplifier.

**Plot A** shows several measurements of harmonic distortion and noise with a bandwidth of 80 kHz. Two measurements were made at a power of 1 W with 8-Ω and 4-Ω loads, one measurement was made at 50% maximum power level with an 8-Ω load, and the final measurement was made with the same output voltage and a 4-Ω load. The four curves are very close together, which suggests that the amplifier is practically insensitive to the load impedance.

**Plot B** shows distortion plus noise as a function of output amplitude with an 8-Ω load. At power levels up to 0.5 W the measured value is determined by the very low noise level. Above this level the distortion increases gradually until approximately 21 W. At this point the amplifier departs from linear operation and enters a soft-clipping region. The soft-clipping region extends over roughly the final ten watts of the amplifier's output power (or the final 3.5 volts of its maximum output voltage). This measurement was made using a 1-kHz signal and a bandwidth of 20 kHz to make the effect of the harmonic components more visible.

**Plot C** shows a Fourier analysis of a 1-kHz signal at 1 W with an 8-Ω load. Here the harmonic distortion is dominated by the second harmonic, which lies at a level of approximately -104 dB. This makes it negligible. The same holds true for the effect of the magnetic field of the mains transformer, which is responsible for the 50-Hz component in the plot. This level corresponds to a power of only 10 pW.



of the transformers are connected to the printed circuit board holding the smoothing capacitors and rectifier diodes. The electrolytic smoothing capacitors are quite ordinary types (6800  $\mu$ F, 35 V) with radial leads and a diameter of 25 mm (there's no room in the enclosure for anything larger). The type used here has a quite low profile (only 30 mm), so there's more than enough room in height.

Due to the relatively low supply voltage, we used Schottky rectifiers made by ON Semiconductor. They are rated at 100 V / 20 A peak. The forward voltage drop per diode is only 0.5 V at 3.5 A.

Three-way circuit-board terminal blocks are used for all external leads to simplify fitting the wiring and any necessary maintenance. There are also two LEDs on the circuit board (one per channel) to serve as supply voltage indicators. If the mains switch does not have a pilot lamp (on the front panel), they should be used instead.

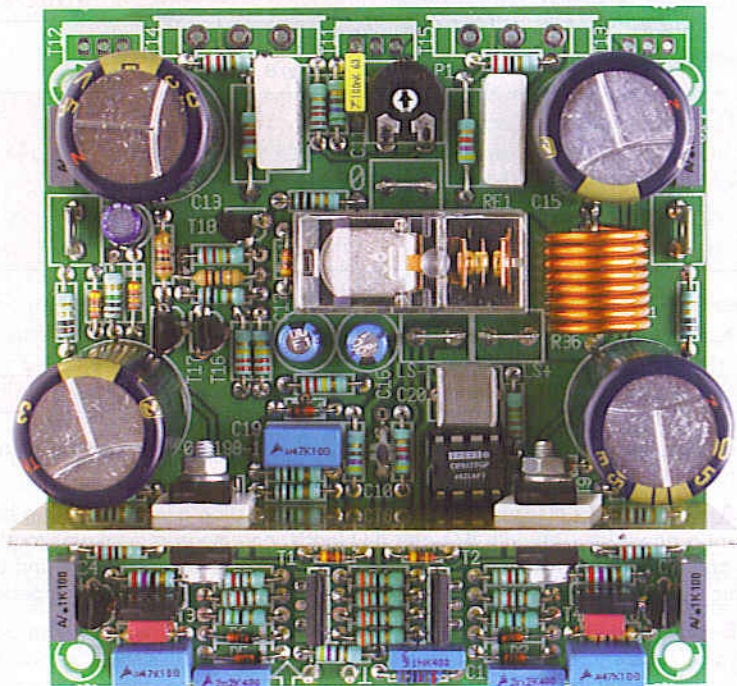
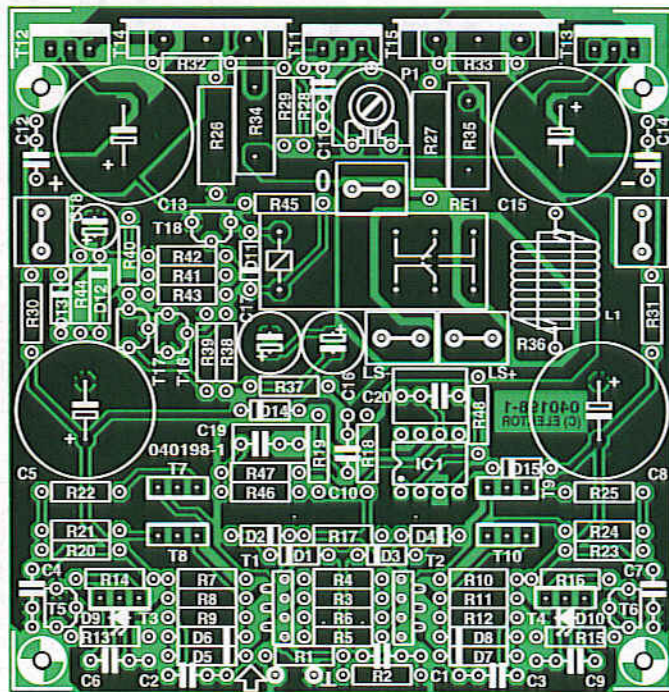
## Construction

The compact, double-sided printed circuit board for the amplifier is shown in **Figure 6**. We don't often use double-sided boards for *Elektor Electronics* final amplifiers, but here this provides definite advantages and yields shorter signal paths between the components. Fitting the components to the board should not pose any particular difficulties (no SMDs this time), but you do have to work accurately. All of the components are very close together, which means you have to fit them tidily, use components with the proper dimensions, and take care when fitting them (correct polarity and value).

There are a few details that deserve special mention. LEDs D9 and D10 must be fitted with their flat sides in contact with T3 and T4 for good thermal coupling, in order to make the current sources temperature-independent. Transistors T7-T10 are screwed to a common heat sink. Use a piece of aluminium for this, with dimensions of 85  $\times$  38 mm (the same as the circuit board) and a thickness of 1.5-2 mm. The height is such that the top panel of the enclosure can just be fitted in place. Use ceramic insulators (Fischer type AOS 220) for all four transistors, and screw them in place in facing pairs.

Use the specified low-inductance resistors for R34 and R35, since otherwise there's a very good chance that the amplifier will be unstable.

Coil L1 can be made by winding 1.5-mm



## COMPONENTS LIST

Amplifier board (040198-1)

### Resistors:

R1, R17, R19 = 470 $\Omega$   
 R2 = 10k $\Omega$   
 R3-R6 = 33 $\Omega$   
 R7, R8, R10, R11 = 820 $\Omega$   
 R9, R12 = 15 $\Omega$   
 R13, R15, R40 = 1k $\Omega$   
 R14, R16 = 270 $\Omega$   
 R18, R26, R27 = 4k $\Omega$   
 R20, R23, R32, R33 = 22 $\Omega$   
 R21, R22, R24, R25 = 10 $\Omega$   
 R28 = 560 $\Omega$   
 R29 = 120 $\Omega$   
 R30, R31, R45 = 1 $\Omega$

R34, R35 = 0 $\Omega$ 22 MPC71  
 R36 = 2 $\Omega$ 2, 1W (e.g. Farnell # 306-0408)  
 R37-R39 = 100k $\Omega$   
 R41 = 10M $\Omega$   
 R42, R48 = 330 $\Omega$   
 R43, R44, R46, R47 = 1M $\Omega$   
 P1 = 250 $\Omega$  preset

### Capacitors:

C1 = 1nF  
 C2, C3 = 2nF2  
 C4, C7, C11, C12, C14 = 100nF  
 C5, C8, C13, C15 = 3300 $\mu$ F 35V, radial, lead pitch 7.5mm, diam. 18mm max. (e.g. Farnell # 303-6467)

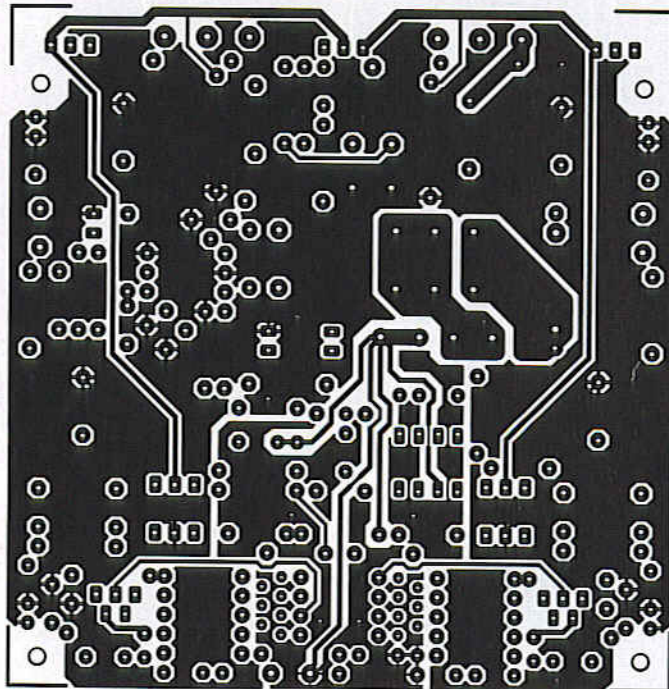
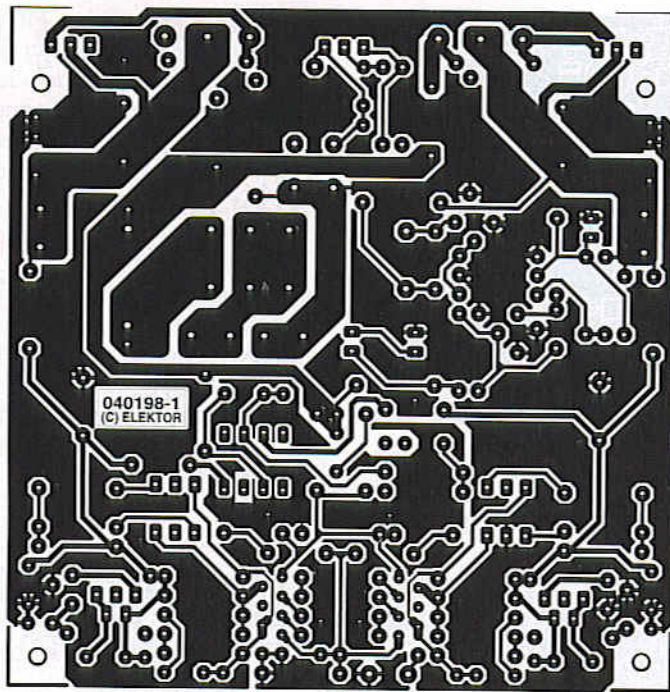


Figure 6. The mono amplifier circuit board is double-sided and through-hole plated to keep the signal paths between the components short and avoid wire bridges.

diameter enamelled copper wire on a 10-mm drill bit (the smooth part, of course). Leave fairly generous leads and scrape them nicely clean with a small knife. Then insert R36 in the coil, bend over its leads and fit the assembly to the circuit board. Then solder the coil and resistor in place. Cut off the free ends of the coil leads after they are soldered, but not too close to the circuit board.

Don't solder the driver transistors, output transistors or quiescent-current transistor to the circuit board just yet. The leads of these transistors must first be bent to the right spacing, so they can rest properly on the heat sink without any mechanical strain after being fitted. That is described in detail under 'Final assembly'.

Next comes the indicator circuit board (Figure 7). It doesn't involve much out of the ordinary. R16, R17, R33 and R34 must be fitted a bit above the board and bent slightly away from the decoupling capacitors, since they must dissipate a fair amount of heat. If you wish, you can use a multimeter to adjust presets P1 and P2 to 210  $\Omega$  before soldering them to the board (refer to 'Alignment' at the end of the article). For C1 and C2, be sure to buy a type that has the right dimensions to fit on the circuit board.

The power supply board shown in Figure 8 can be quickly put together, but here again you must be sure to use capacitors with the right dimensions and the proper type of Schottky diode. Don't forget the wire bridges under and between D2/D3 and D7/D8.

C6,C9,C19 = 470nF  
C10 = 15pF  
C16,C17 = 47 $\mu$ F 25V, radial  
C18 = 10 $\mu$ F 63V, radial  
C20 = 2 $\mu$ F2 MKT, lead pitch 5mm or 7.5mm

#### Inductors:

L1 = 8 turns 1.5-mm diam. (SWG30)  
enamelled copper wire, inside diam. 10mm

#### Semiconductors:

D1-D4,D11-D13 = 1N4148  
D5-D8 = Zener diode, 4V7, 0W5  
D9,D10 = LED, flat, red  
D14,D15 = Zener diode, 5.6V, 0.5W  
T1 = 2SC3381BL (Toshiba, Huijzer,

Segor-electronics)  
T2 = 2SA1349BL (Toshiba, Huijzer, Segor-electronics)  
T3,T7,T8 = 2SA1209 (Sanyo, Farnell # 410-3841)  
T4,T9,T10 = 2SC2911 (Sanyo, Farnell # 410-3853)  
T5,T6 = BF245A  
T11,T12 = 2SC5171 (Toshiba, Huijzer, Segor-electronics)  
T13 = 2SA1930 (Toshiba, Huijzer, Segor-electronics)  
T14 = 2SC5359 (Toshiba, Huijzer, Segor-electronics)  
T15 = 2SA1987 (Toshiba, Huijzer, Segor-electronics)  
T16,T17 = BC547B

T18 = BS170  
IC1 = OPA177GP (Texas Instruments/Burr-Brown, e.g. Farnell # 205-023)

#### Miscellaneous:

K1-K5 = PCB-mount spade (Faston) terminal, vertical, 2 pins  
RE1 = PCB relay 24V, 16A, 1100 $\Omega$  (e.g. Omron G2R-1-24 VDC)  
Heat sink, 1.25 K/W e.g. (Fischer SK411, height 50mm)  
Ceramic insulators for T7-T10 (Fischer AOS220)  
Mica insulating washers for T14 & T15 (e.g. Conrad Electronics # 189049)  
Enclosure: e.g. UC-202H/SW (Monacor/Monarch)

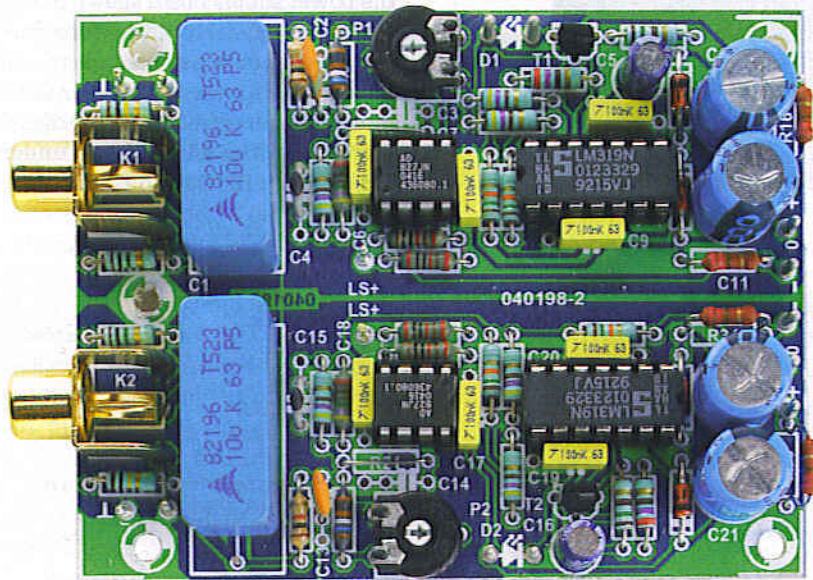
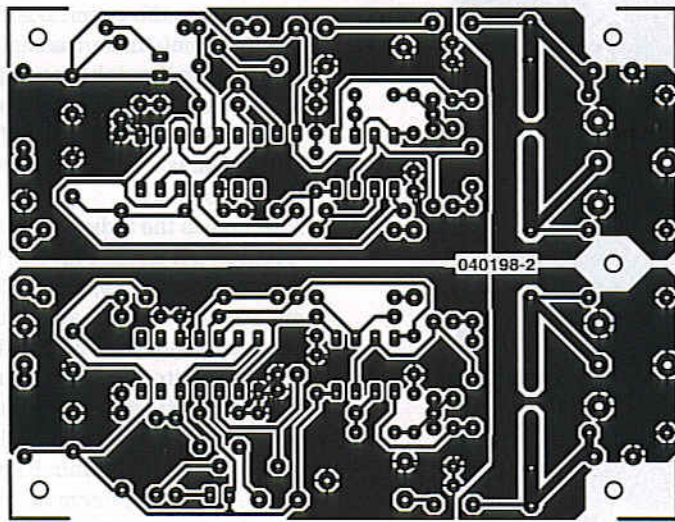
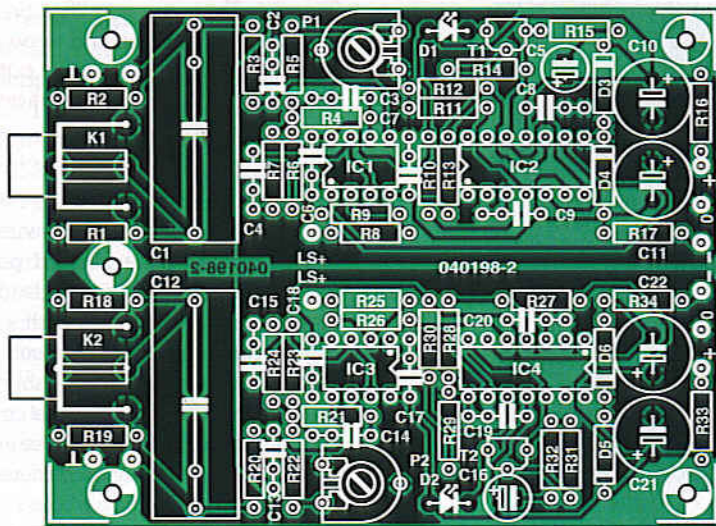


Figure 7. The indicator circuit board also holds the input capacitors (C1 and C12) for the amplifier boards.

## COMPONENTS LIST

Indicator board (040198-2)

### Resistors:

R1,R18 = 1M $\Omega$   
 R2,R19 = 100k $\Omega$   
 R3,R20 = 1k $\Omega$   
 R4,R21 = 0 $\Omega$  (wire bridge)  
 R5,R22 = 1k $\Omega$ 69  
 R6,R23 = 4k $\Omega$ 75  
 R7,R11,R12,R24,R28,R29 = 470 $\Omega$   
 R8,R25 = 20k $\Omega$   
 R9,R26 = 10k $\Omega$   
 R10,R13,R27,R30 = 15k $\Omega$   
 R14,R31 = 270 $\Omega$   
 R15,R32 = 150 $\Omega$   
 R16,R17,R33,R34 = 220 $\Omega$ , 1W PRO1  
 (Vishay BCcomponents, Farnell # 337-778)  
 P1,P2 = 500 $\Omega$  preset

### Capacitors:

C1,C12 = 10 $\mu$ F 63V MKT, lead pitch 22.5/27.5mm, W x L = 11 x 31mm max.  
 (e.g. Farnell # 400-2015)  
 C2,C13 = 470pF  
 C3,C14 = not fitted  
 C4,C15 = 15pF  
 C5,C16 = 22 $\mu$ F 40V, radial  
 C6-C9,C17-C20 = 100nF  
 C10,C11,C21,C22 = 470 $\mu$ F 25V, radial

### Semiconductors:

D1,D2 = LED, red, low-current, 3mm, 20mcd at 2mA (Kingbright L-934LSRD, Farnell # 637-075)  
 D3-D6 = Zener diode, 15V 1.3W  
 T1,T2 = BF245A  
 IC1,IC3 = AD827JN (Analog Devices, Farnell # 246-165)  
 IC2,IC4 = LM319N

### Miscellaneous:

K1,K2 = cinch socket, PCB mount (e.g. Monacor T-709G)

## COMPONENTS LIST

power supply board (040198-3)

### Resistors:

R1,R2 = 6k $\Omega$

### Capacitors:

C1-C4,C11-C14 = 47nF ceramic, lead pitch 5mm  
 C5,C6,C8,C9,C15,C16,C18,C19 = 6800 $\mu$ F 35V, diam. 25mm, lead pitch 10mm (Farnell # 652-090)  
 C7,C10,C17,C20 = 100nF MKT, lead pitch 5mm or 7.5mm

### Semiconductors:

D1-D4,D6-D9 = Schottky rectifier, 10A, 100V, TO-220AC package (e.g. ON Semiconductor MBR10100, Farnell # 878-443)  
 D5,D10 = LED, red, low-current

### Miscellaneous:

K1-K4 = 3-way PCB terminal block, lead pitch 5mm

Finally there is the small circuit board with the mains fuses and terminal blocks for distributing the mains voltage (Figure 9). Of course, this board isn't essential, but it makes the wiring quite a bit easier (and safer!).

### Final assembly

As we already mentioned, the amplifier uses the same type of enclosure as the 'High-End preamp' preamp. That's why we went to so much trouble to keep everything as compact as possible. For the heat sinks, we looked for types that were not too long and still

had sufficiently low thermal resistance. We finally settled on the Fisher SK411, which with its modest dimensions of 116.5 × 50 × 50 mm leaves enough space between the heat sinks to fit the loudspeaker terminals (using relatively small types) and the input connectors. To maximise the available space, we milled a 1.7-mm rebate around the edge of the heat sinks, so their bases fit nicely between the two fastening rails. This also causes the edges of the heat sinks to be flush with the side faces of the enclosure. Each heat sink is secured by four M3 screws fitted through the heat sink and the rails.

The head of an M3 screw will fit between the cooling fins of this type of heat sink. In principle, the output transistors could be attached the same way. This would make assembly a bit easier, but it would also make the circuit board unnecessarily large.

A small 1.5-mm aluminium plate can be fitted between the two heat sinks (measure carefully) to hold the speaker terminals and input connectors. The original rear panel of the enclosure is not used.

There's actually not any room left for the mains cable (and certainly not for an IEC mains inlet). In our prototype, we used a sturdy mains cable and strain relief routed through the bottom plate next to the circuit board with the fuses. In this case, the enclosure must rest on high feet that are high enough to prevent the mains cable from being pinched off.

Fit the mains transformers as close as possible to the front panel. The mains switch and LEDs from the overdrive indicator can then be fitted on either side of the fuse circuit board and the transformers. Attach the fuse circuit board to the base plate using 10-mm standoff sleeves with nylon screws and nuts (the terminal blocks we used are partially open at the rear). This ensures Class-II isolation (be sure to read the instructions on the 'Safety Guidelines' page). In general, always pay careful attention to the isolation of components carrying mains voltage. Maintain a distance of at least 6 mm from parts that can be touched by users.

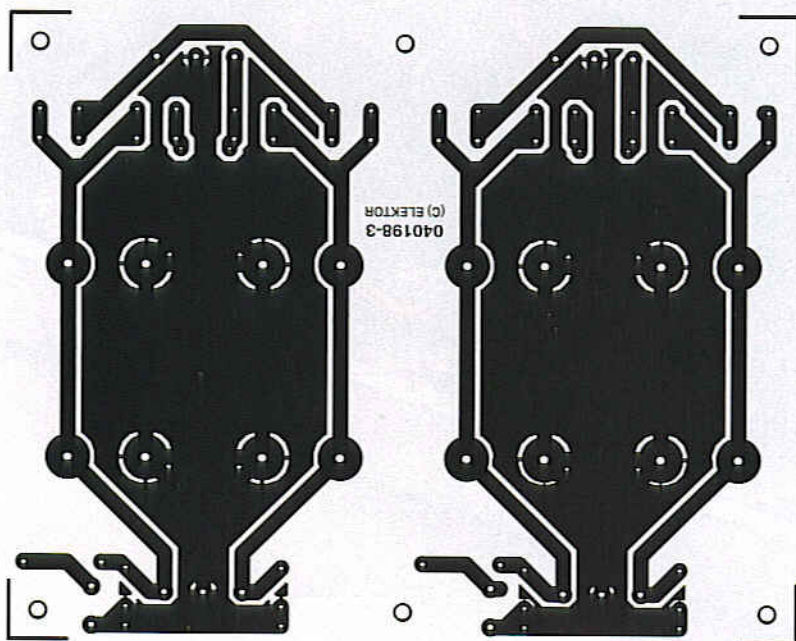
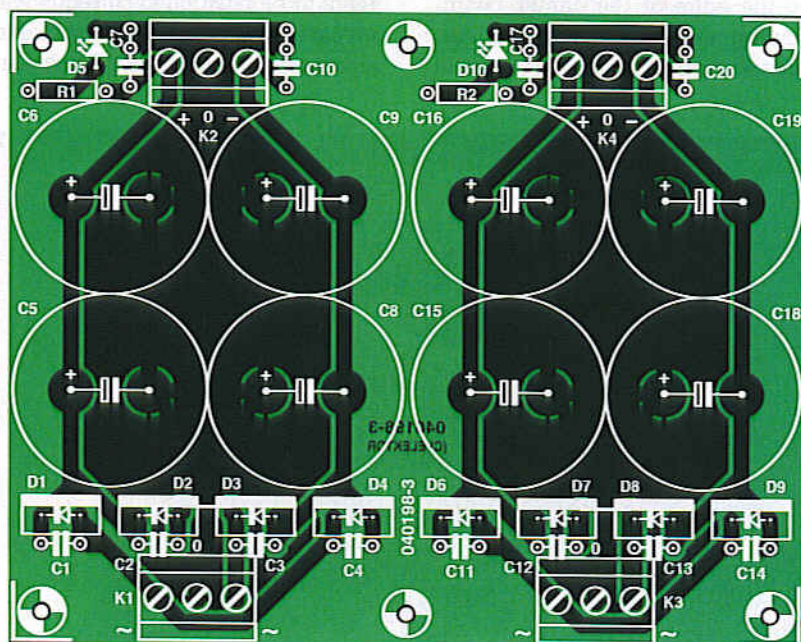
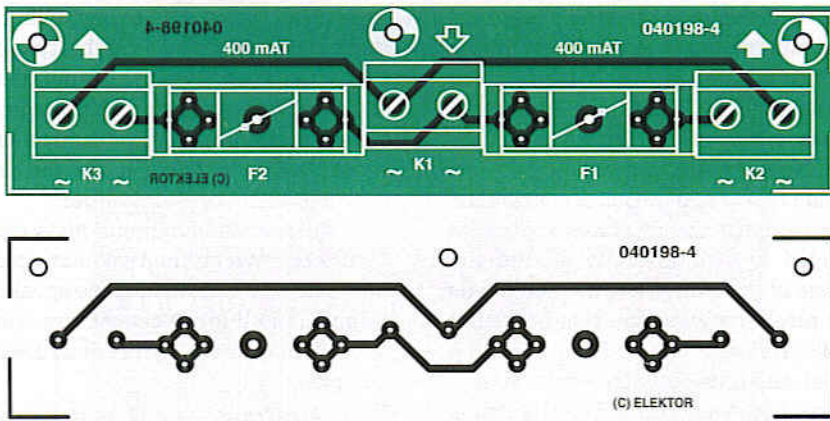


Figure 8. The power supply circuit board holds a total of eight electrolytic capacitors to power two amplifier boards.

For each power supply terminal, insert the supply leads for the amplifier boards and indicator board together in the appropriate terminal blocks. Heavy wire with a cross-sectional area of 2.5 mm<sup>2</sup> must be used for the amplifier boards, but thin flexible wire is adequate for the overdrive indicator board. Make the supply leads for the amplifier boards as short and direct as possible. We crimped tab connectors to the ends of the leads, but you can also solder them directly to the boards. Connect the speaker outputs on the circuit boards to the output sockets in the same manner. At the sockets, we simply fitted wire lugs to the ends of the wires, which avoids the contact resistance of an additional plug. The power supply leads for the overdrive indicator board can be simply soldered in place. Fit the overdrive indicator board in the middle between the amplifier boards. The input sockets will then be almost



## COMPONENTS LIST

Fuse board (040198-4)

### Miscellaneous:

K1-K3 = 2-way PCB terminal block,  
lead pitch 7.5 mm  
F1, F2 = fuse, 400mAT (time lag), with  
PCB mount holder

Figure 9. A small auxiliary circuit board for the fuses and mains connections.

flush with the rear panel. Naturally, it will take a bit of measuring and fitting to get the holes for the connectors in the right places.

The manner in which the heat sinks

are attached causes the mounting surface to be approximately 6 mm away from the edge of the circuit board, assuming that the amplifier circuit boards are attached directly to the

rails. This means that the leads of the transistors must be bent twice allow them to be positioned correctly without creating permanent mechanical stresses in the transistors. For the large



## PCBs:

Required for a stereo amplifier  
(see Readers Services page):

- 2 ea. order code **040198-1**
- 1 ea. order code **040198-2**
- 1 ea. order code **040198-3**
- 1 ea. order code **040198-4**

output transistors, the first bend will have to be somewhat closer to the plastic package than what is intended (in the wide part), since otherwise the leads will touch the rails or won't fit at

all. Another possibility, which has the disadvantage that it weakens the structure, is to file away enough metal at the appropriate locations to provide adequate clearance. We intentionally rejected this option.

Once you have taken care of this detail and the transistors can easily be placed flat against the heat sink with their leads passing freely through the holes in the circuit board, you can mark the locations of the mounting holes on the back of the heat sink. Naturally, you should do this before the transistors have been soldered to the circuit board, but after the final holes for fastening the amplifier circuit boards have been made in the bottom plate. Once the output transistors and their drivers have been fitted to the heat sink and soldered to the circuit boards, the bottom plate can be removed quite easily.

Be sure to not exert too much force on the leads of the transistors when the boards are suspended this way.

Power transistors T14 and T15 must be fitted to the heat sink using insulators (mica washers), while the other three transistors (T11, T12 and T13) can be screwed directly to the heat sink. Be sure to use thermal paste with all of the transistors.

After you have made all the mounting holes for the remaining circuit boards, transformers, mains switch and LEDs (in the front panel) and ventilation holes in the enclosure, you can screw everything else in place and fit the wiring.

Use well-screened audio cable to connect the inputs of the amplifier boards to the terminals near the input sockets on the overdrive indicator board. Use the two ground terminals next to the input sockets to connect the enclosure

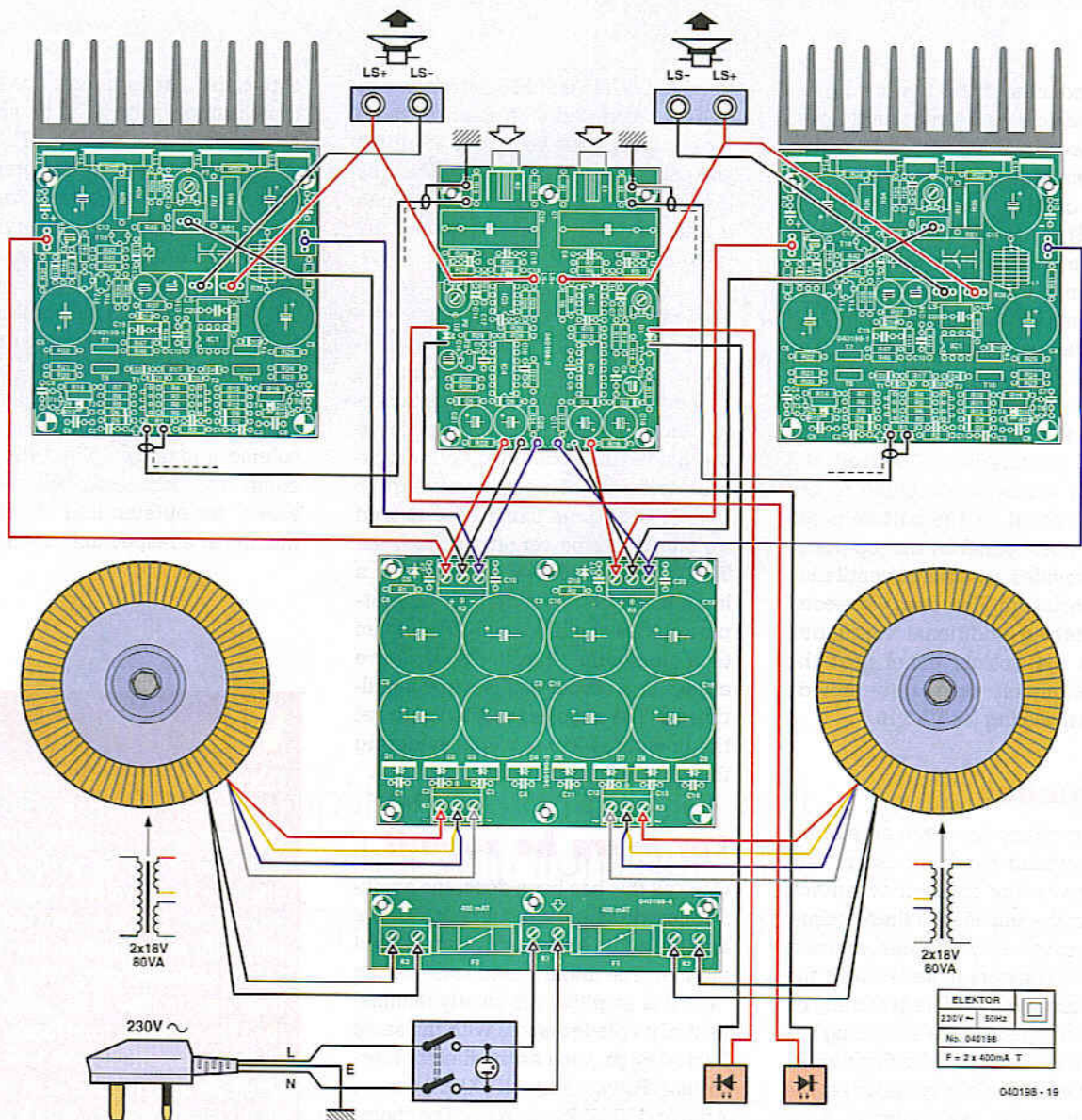


Figure 10. The wiring diagram shows the proper way to connect everything together inside the enclosure.

## Transistor selection

Toshiba type 2SC3381 and 2SA134 dual transistors are used for the differential amplifiers in the input stage. These transistors may be difficult to obtain, but they are practically the only good complementary dual transistors still commercially available.

We selected Sanyo type 2SC2911 and 2SA1209 transistors for the differential amplifiers in the voltage gain stage. These transistors come in a TO-126 package and have outstanding linearity combined with low output capacitance (3 pF and 4 pF, respectively), and they can handle up to 160 V. The maximum dissipation is 10 W (4 W at 100 °C), and the maximum rated collector current is 200 mA for 1 second or 140 mA continuous. The maximum allowable emitter-base voltage is only 5 V, so a pair of 4.7-V Zener diodes are connected back to back between the outputs of each of the input differential amplifiers (D5–D8). The dual transistors have similar restrictions, so two back-to-back diodes are placed between the inputs of each of the differential amplifiers (D1–D4).

Matching the respective pairs of transistors (NPN-NPN and NPN-PNP) will certainly help improve the quality of the amplifier, so you should pay attention to the  $h_{FE}$  parameter classification (GR/BL, R/S/T/, and R/O) when purchasing these components.

For the output transistors and drivers we chose some old friends, namely the transistors used in the Titan 2000 amplifier (Elektor Electronics, February–May 1999). These output transistors have a relatively constant  $h_{FE}$  up to 5 A, so they do themselves proud in this amplifier. They can handle a maximum continuous current of 15 A, which in practice means that the amplifier can be used with load impedances as low as 1.5  $\Omega$ .

For integrator IC1 we selected an OPA177, which has a very low offset voltage (100  $\mu$ V between  $-40$  °C and  $+85$  °C). This opamp has a maximum bias current of  $\pm 6$  nA, which makes a small contribution to the residual offset at the output of the amplifier ( $\pm 2$  mV maximum, equal to 6 nA  $\times$  330 k $\Omega$ ).

We chose a MOSFET for T18 in the protection circuit so that voltage divider R43/R44 could have a high impedance. This allows the capacitance of C18 to be kept relatively small, which has two benefits: the dimensions of C18 can be kept modest, and the DC protection circuit does not have to draw so much current from C18.

to the grounds of the two channels. This avoids creating any ground loops. The measurement inputs for the amplifier output signals are located in the middle of the overdrive indicator board. The easiest way to connect them is to use thin, flexible wire to connect them to the output sockets.

For the sake of clarity, the complete wiring diagram of the final amplifier is shown in Figure 10.

One of the cover panels for the enclosure is solid, while the other one has punched perforations. To keep the assembly sturdy, we decided to use the solid panel for the bottom panel and the 'open' panel for the top panel, which provides continuous ventilation for the enclosure. However, we recommend making additional ventilation holes in the bottom panel near the amplifier circuit boards to provide additional cooling for T7–T10.

### Alignment

After everything has been assembled and the wiring has been completed, you come to the moment when you switch on the amplifier for the first time. As a precautionary measure, connect 33  $\Omega$ , 5 W resistors in series with the power supply lines before switching on the amplifier, just in case something has been fitted incorrectly. Also first turn P1 fully to the left (anticlockwise) to set the quiescent current to a minimum. After this, you can switch on the power. To set the quiescent current, you can measure the voltage between the emit-

ter of T14 or T15 and R36 (which should be easily accessible with a measurement probe). Adjust the voltage to 22 mV. If you can do this for both output stages and the settings remain stable, you can switch off the amplifier and remove the resistors from the supply leads.

The easiest way to adjust the overdrive indicator is to use an oscilloscope, but you can certainly manage without one. After the quiescent current has been set, drive the amplifier to just below its maximum output amplitude using a 1-kHz sine-wave signal. This is best done using an 8- $\Omega$  load resistor with a power rating of at least 30 W, but it can also be done without a load. Measure the signals at the outputs of IC1a and IC3a, and adjust them to a minimum. If you do not have access to a scope, you can use a multimeter. The simplest method is to set the presets to 210  $\Omega$  before soldering them to the circuit board.

### Let there be sound!

Once all this has been done, the amplifier can do what it's supposed to do: amplify audio signals in a very refined manner. The initial sound impressions from this amplifier are clearly reminiscent of its predecessors with the same basic design, such as the *Elektor Electronics* Power Amp, HEXFET Power Amp and IGBT Power Amp. The choice of components and the compact, double-sided circuit board layout appear to bear fruit here in the form of an

especially transparent, unstrained reproduction with a very spacious, well-detailed stereo image. This amplifier demands a pair of outstanding loudspeakers, preferably relatively large types (since they usually have better efficiency than compact speakers). After all, the output power is rather modest, but that shouldn't present a problem for anyone outside the ranks of hard-rock, grunge and heavy metal fans. The accurate indicators are quite helpful in setting the maximum volume, and this amplifier shows once again how little power is actually necessary for outstanding stereo reproduction at a respectable sound level.

(040198-1)

## Warning

This design incorporates power supply transformers connected to the mains. That can lead to potentially lethal situations if you do not pay careful attention to the safety regulations for such circuits. Please be sure to carefully follow the instructions on the Electrical Safety guidelines page, which appears from time to time in the magazine. If the type of mains transformer shown on the schematic diagram is used, this circuit can be assembled in an enclosure as a Class-II device. Attach the type label shown on the wiring diagram to the assembled enclosure.

# OPINIONS ON VALVES

## Valves versus transistors



We have two audio amplifier design articles in this issue: one with valves and the other with transistors. They are just as different as people's opinions on the issue of valves versus transistors.

Does it make sense to go back to the amplifier technology of our grandparents? Is there really such a thing as the 'legendary valve sound'? Or is this only a question of our emotions refusing to bow to physical measurements? We attempt to resolve this issue by viewing it

from three different perspectives. One belongs to a designer in our own Elektor Electronics lab, a second one belongs to the world of professional studio engineering, and a third one combines the physical and musical aspects.



Figure 1. The Schoeps M222 valve microphone is designed for fixed or portable use in professional environments. The 'Harmonics' rotary switch allows the user to adjust the valve settings in order to obtain the desired sound.

## The audio designer: no emotions

For many years now, Ton Giesberts has been a stalwart of the small but tight-knit team that mans the *Elektor Electronics* laboratory. During this time he has become a specialist in audio circuitry. He has been responsible for most of the major audio designs we have published in *Elektor Electronics*, such as the All Solid-State Preamplifier (1989), the Medium Power AF Amplifier (1990), the Output Amplifier for Ribbon Loudspeakers (1992), the Battery-Operated Preamplifier (1997), the Titan 2000 (1999) and the Crescendo ME (2001) to mention but a few. This very issue features his latest creation, which 'naturally' uses transistors: the splendid, compact 'High-end Power Amplifier'.

Given the never-ending dispute between valve and transistor enthusiasts over what sounds better, and in light of the fact that we feature both types of amplifiers in this issue, we naturally would like to hear Ton's thoughts on this subject. We should start by saying that Ton is an absolute stickler for technical quality, so DIY designs with poor performance figures haven't a chance of leaving the audio lab with his approval.

Ton has a clear-cut opinion of valve amplifiers: "They're simply no good! They colour the sound, and they have poor damping, which degrades the sound. A transistor amplifier does a much better job of keeping the speakers under control, and it adds almost nothing to the sound." According to him, that's not actually the fault of the valves, but instead comes from the fact that most valve amplifiers are poorly designed. What's more, the output transformer in a valve output stage forms an additional obstacle to efforts to obtain realistic reproduction. He bases his opinion on the many measurements he has made on valve amplifiers over the years. Ton doesn't have anything

against valves as such. He thinks that excellent designs can be made using them, but his experience is limited to transistor designs, so he's reluctant to tackle designing a valve amplifier. "That's the wrong challenge for me; I definitely belong to the silicon generation."

According to Ton, there are some other serious drawbacks to valve amplifiers besides their sound quality. "In our age of environmental awareness, how can you justify marketing an amplifier with such poor efficiency? And what's more, valves have a relatively short life, and I wonder if they don't contain poisonous substances. Maybe they should be treated as hazardous waste!"

As you can imagine, Ton would never build or buy a valve amplifier. He thinks it's perfectly possible to design valve amplifiers and transistor amplifiers with equally good characteristics, but it's a lot harder to do so using valves.

"If someone chooses a valve amplifier for its 'warm' or 'natural' sound, that's fine with me, as long as he or she is happy with it. But I want a system that adds as little as possible to the original sound; the output signal must be the best possible copy of the input signal."

## The valve microphone: physics versus emotions

By Bernhard Vollmer

The author has been actively involved in quality assurance at Schoeps, a German manufacturer of studio microphones, for nearly two decades. As a supplier to Schoeps, his company Elvo makes the model M222 valve microphone ([www.m222.de](http://www.m222.de)).

What would music be without emotion? Should our experience, ears and sensitivity take precedence over the technical aspects? Improvements are only conceivable if well-founded understanding provides the basis for further development. Even so, comparative listening tests are always necessary along the way and for judging the end result. But what is the proper way to make comparisons? Human senses are not absolute; anyone who spares himself the trouble of making comparative tests and only listens to a single product will always fall victim to his expectations ('valve sound is warm because valves are warm'). What makes things worse is that people usually don't realise this, so they base their work on preconceived notions.

Generally speaking, there are two questions that always have to be answered:

1. Is there a difference in sound, and if so, what is its nature?
2. Which result is better?

Prolonged listening sessions are necessary to answer these questions. Whether you find something warm or cold also depends on the temperature of your previous surroundings. To verify the assumption that 'A' sounds better than 'B', your only option is to directly compare them one after the other without any delay in between, possibly by switching back and forth between the two while the sound is playing. In this way, you can recognise whether there is any difference, how large it is, and what its nature is. Any pause between the two signals poses a large risk of false assessment.

Another important consideration in such 'A'-B' comparisons is that the levels of the signals being compared must be absolutely identical. People cannot hear a difference of only 0.5 dB in sound level as a difference in loudness. However, the signal with the higher level will unconsciously be judged to sound better.

A comparative test with switchable valve signal paths is pointless if there are significant measurable differences in frequency responses, or if you do not carefully match the signal levels. Measurable differences should be eliminated as much as possible before you put your ears into play. Otherwise you will only hear the prevailing differences, which you could have already demonstrated by measurement.

Many comparative tests of valve and transistor amplifiers have already been conducted, and such tests lead to comparable results if they are done properly. To avoid going into unnecessary detail, these results can be summarised as follows.

At low signal levels, valves are noisier, but the differences in sound are small. At medium signal levels, the differences are scarcely audible. At relatively high signal levels, valves increasingly create harmonic signals, especially at low frequencies. As a result, the sound is no longer neutral as with transistors, but the result can sound more pleasant, particularly with highly impulsive sound events (such as speech and guitar music) As the harmonics of low frequencies are still low frequencies, the resulting sound is often described as being warmer or fuller. If the designers haven't made any gross errors, the differences between valve and transistor amplifiers are much smaller than many people might think.

The Schoeps M222 valve microphone is designed for valve enthusiasts and can be used as a fixed or portable microphone in professional environments. The valve settings can be modified by the user to obtain the desired sound.

## The valve sound: myth or reality?

By Klaus Rohwer, PhD

The author is a physicist and amateur jazz harmonica player (<http://www.klausrohwer.de/>).

That famous valve sound, does it really exist? Yes, it does — but it doesn't have to come from a valve! Here we have to make a distinction between devices for producing music and devices for reproducing music. The first category includes music amplifiers and effect generators, while the second category includes hi-fi and high-end sound systems for the living room. The first type of equipment is optimised for high efficiency (volume) and designed to enable musicians to obtain the sound they want to produce. The second type of equipment should be optimised to reproduce the input signal in an amplified form with the least possible adulteration or distortion. However, many musicians and audio enthusiasts evidently believe that something must glow somewhere in order to generate a 'warmer' sound. I consider this to be purely an *idée fixe*.

Firstly, as regards music production, what we mean here by 'valve sound' is primarily demanded by guitar players

and blues harmonica players. The sound of a jazz guitar is just as inconceivable without valve sound as the sound of Chicago blues. It consists of four components:

- soft clipping, instead of the hard clipping characteristic of transistor amplifiers;
- a compression effect, due to a power supply with high internal impedance;
- a 'fuller' sound, due to additional even harmonics produced by a characteristic curve that is asymmetric (even in the small-signal range);
- increased coloration by loudspeaker characteristics, due to a high-impedance output.

Soft clipping results from the gradual bend in the gain characteristic (the ratio of output voltage to input voltage), in contrast to the sudden bend in the characteristic curve of a normal transistor amplifier. Symmetric clipping, whether hard or soft, always produces only odd harmonics in the output signal. However, with soft clipping the amplitude of the higher-order harmonics drops much faster than with hard clipping, with the result that the sound is less 'hard' (Figure 2). Similar considerations apply to high-impedance drive (current drive) for the loudspeakers. Signal compression can also be obtained using transistors, although it is more difficult than with valves. In the present age of digital signal processors (DSPs), it can be achieved quite easily, and there are several commercially available effect generators and even complete amplifiers (such as those made by Line 6; see the weblink) that can emulate certain types of amplifiers with extraordinary fidelity, as the author has been assured by several users.

As regards music reproduction, if you want to depart from a straight-line characteristic, which is actually the ideal for any hi-fi or high-end amplifier, you don't necessarily have to use valves, since the same results can be obtained using transistors, as already mentioned.

(0404601-1)

### Weblinks:

[www.m222.de](http://www.m222.de) (description of the Schoeps M222 microphone)

[www.schoepsclassics.de](http://www.schoepsclassics.de) (older-model Schoeps valve amplifiers)

[www.line6.com/products.html](http://www.line6.com/products.html) (effect processors and software for valve amplifier emulation)

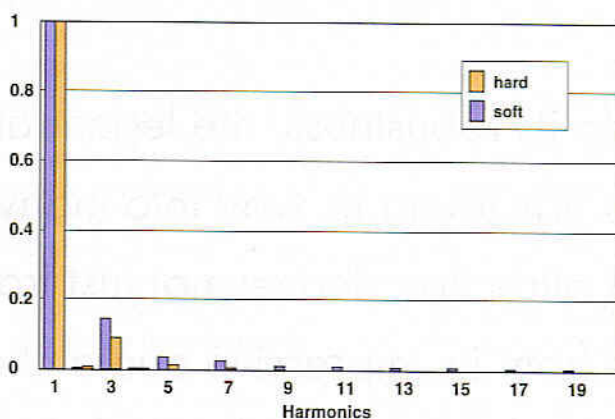


Figure 2. With soft clipping, the amplitude of higher-order odd harmonics in the output signal decreases much more quickly than with hard clipping, so the sound is significantly less harsh.

# EL156 AUDIO POWER

Gerhard Haas



Thanks to its robustness, the legendary EL156 audio power pentode has found its way into many professional amplifier units. Its attraction derives not just from its appealing shape, but also from its impressive audio characteristics. We therefore bring you this classical circuit, updated using high-quality modern components.

# AMPLIFIER

## Return of a legend

The EL156 was manufactured in the legendary Telefunken valve factory in Ulm, near the river Danube in Germany. The EL156 made amplifiers with an output power of up to 130 W possible, using just two valves in the output stage and one driver valve. Genuine EL156s are no longer available new at realistic prices, and hardly any are available second-hand. The original devices used a metal valve base which is still available, but a new design using original valves and metal valve bases would anyway be impractical, given the lack of availability at reasonable prices.

### Made in China

Fortunately this valve is still being produced in China, using the original Telefunken machines. A normal octal base is now used, with pinout the same as that of the EL84, 6L6, KT88 and similar valves. The devices are still not exactly cheap, but the price is not too unreasonable and the valves are generally supplied with bases included. Comparison with original Telefunken valves shows that the devices are a successful mechanical and electrical copy and are suitable for use in a hi-fi amplifier.

Before we proceed to describe the design, we should first look at a few special features of these valves. In the text box we compare the basic specifications of the EL156 with those of the well-known and widely-used EL34. This information will to a large extent determine the design of the amplifier. In order to obtain sufficient output power, the anode voltage must be at least twice as high as the screen grid voltage. The driver circuit must be designed to cope comfortably with the comparatively low-impedance load presented by the grid leak resistors. The popular ECC83 (12AX7) is ruled out, since it operates at only around 1 mA. The ECC82 (12AU7) audio double triode can be operated with an anode current of 10 mA, and so would appear to be suitable; however, its open-loop gain is only 17, which is not

enough to give adequate sensitivity, even before allowing any margin for negative feedback. The ECC81 (12AT7), however, which has an open-loop gain of 60 and which can be operated with anode currents of up to 10 mA, can be used to build a suitably low-impedance circuit.

Two EL156s can be used to produce an output power of 130 W with only 6 % distortion. To improve reliability and increase the life of the valves, however, we have limited the maximum power. A genuine hi-fi output at 100 W with low distortion is better than 130 W at 6 %, especially when there is a large component at the unpleasant-sounding third harmonic.

The whole circuit is built on four printed circuit boards, forming a monoblock. **Figure 1** shows the power supply and the amplifier together. The power supply capacitors are cascaded to filter the high anode voltage in order to obtain the required voltage stability. To supply the relatively high currents required by the screen grids of the EL156s two separate high voltage supplies are produced using bridge rectifiers from two isolated transformer windings ('hi' and 'lo'). Immediately after the rectifiers these supplies are connected in series and individually filtered. Choke Dr1, with a value of 2.3 H, is rated for a current of 0.3 A and filters the anode supply, while Dr2, with a value of 4 H and rated for 0.18 A, filters the screen grid voltage. The driver valve is also powered from the screen grid supply. The screen grid voltage must be well filtered since any hum present on it will be amplified through to the output: the screen grid has some control effect. The values suggested give good filtering and hence low hum. Radial 100  $\mu$ F/500 V electrolytic capacitors are recommended to make the power supply compact; a working voltage of 500 V ensures adequate margin to give reliable operation even in the event of mains overvoltage. Note the discharge resistors in parallel with the electrolytics. The negative grid bias voltage is provided by a diode and

electrolytic capacitor: this voltage is further filtered on the amplifier board.

It is not possible to build an ultra-linear amplifier using the EL156 with a high anode voltage. The same goes for the EL34. The output transformer is therefore connected in such a way that the impedance of the grid connection to the output valve is much lower than in conventional valve circuits, and considerably lower than the maximum permissible value of 100 k $\Omega$ . This relaxes the requirements on the tolerance of the valves, and select-on-test of the valves is not required.

Coupling capacitors C9 to C11 have relatively large values. This is needed to ensure that sufficiently low frequencies can be handled in the low-impedance circuit. The input and the phase inversion stages (V1 and V2 respectively) have relatively low anode and cathode resistors. The supply voltage for the input and phase-inversion stages is regulated by Zener diodes D1 to D4. The operating point of V1 is therefore independent of supply voltage fluctuations caused by the output driver stage. R1 and C2 block high frequencies. Capacitor C4, connected in parallel with negative feedback resistor R11, suppresses high frequency oscillations. C3, between anode and grid of V1a, performs the same task. R4 and R6 are effectively in parallel to AC signals, and, in combination with negative feedback resistor R11, set the overall gain. The amplifier is designed with only a moderate amount of negative feedback: this improves the resulting sound.

An E-1220 transformer (Tr1) with a 1:2 turns ratio is fitted at the input to the amplifier. This gives adequate input sensitivity as well as providing isolation. Differential or quasi-differential audio connections are in theory less susceptible to interference and prevent earth loops. Also, the 1:2 ratio gives an extra 6 dB of sensitivity without added noise, leaving a little more margin in hand for negative feedback. The printed circuit board also allows for a

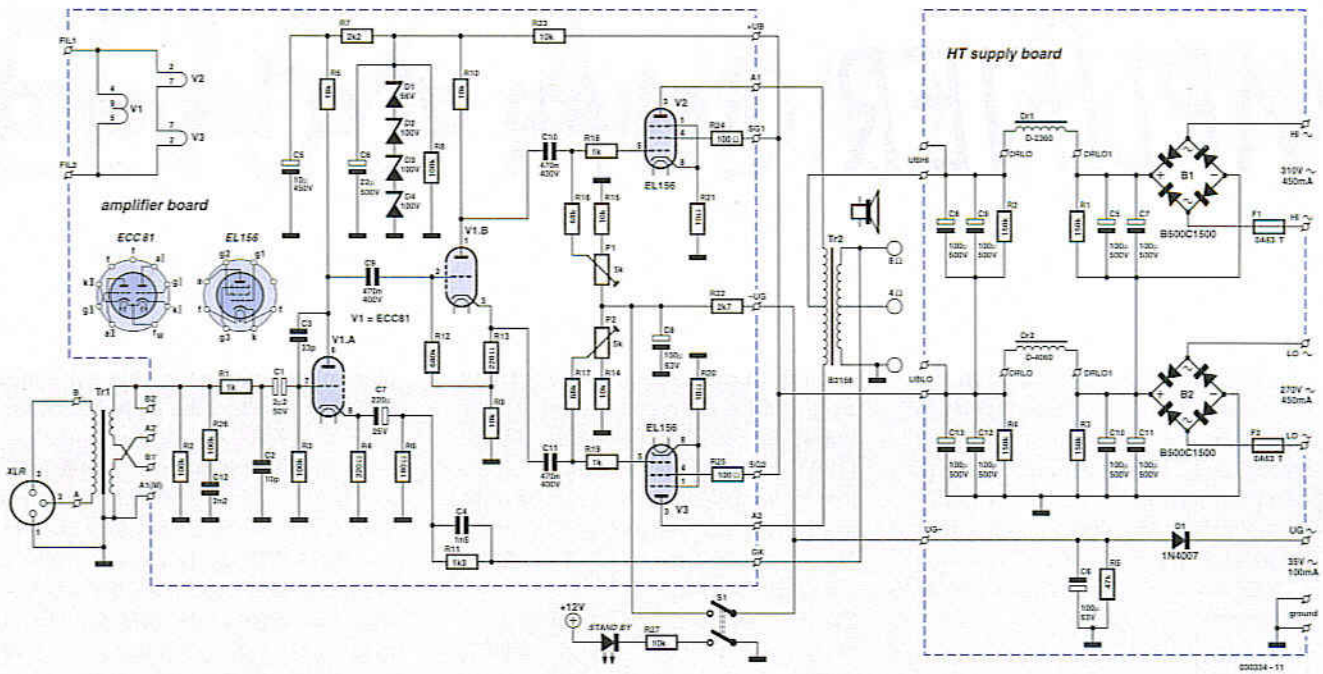


Figure 1. The heart of the valve power amplifier with its output transformer and high-voltage power supply.

1:1 connection, in which case twice the input signal level will be required for full drive. The desired ratio can be selected using wire links. The combination of C12 and R26 compensates for the response of the transformer at higher frequencies.

### Stand by me

Valve power output stages are often designed with a stand-by function. This prolongs the life of the output

stage valves, normally by switching off the anode supply, while the heater and other voltages remain. On leaving stand-by the amplifier is immediately ready for action.

In view of the high anode voltage, an ordinary switch or relay is not suitable. We take a different approach, shorting out R22 using the stand-by switch, so that the negative grid bias voltage on the output stage valves is raised. Only a very small quiescent current now flows. According to the valve data

books this is if anything preferable to switching off the anode supply as prolonged operation with the heater on without applying an anode voltage gradually reduces the emissivity of the cathode. An LED connected to the second pole of the double-pole switch indicates when stand-by mode is active. The LED can be powered from the heater supply.

### DC heater supply

To minimise hum a regulated low drop-out DC heater supply is provided, using the familiar 723 voltage regulator and a MOSFET (Figure 2). The supply has been designed to minimise losses, and to this end the heater filaments of the two EL156s are connected in series. The ECC81 can be arranged so that it operates from a 12.6 V heater supply. At double the voltage (using 12.6 V rather than 6.3 V) only half the current flows, which means that losses in the bridge rectifier are considerably reduced. With the given component values power losses in T1 will be kept low.

A further trick is used to reduce the voltage drop due to the current limit circuit. The 723 includes a silicon transistor for current limiting, whose base-emitter junction senses the voltage across the current limit sense resistors R4 and R5. Normally the silicon transistor would switch off at

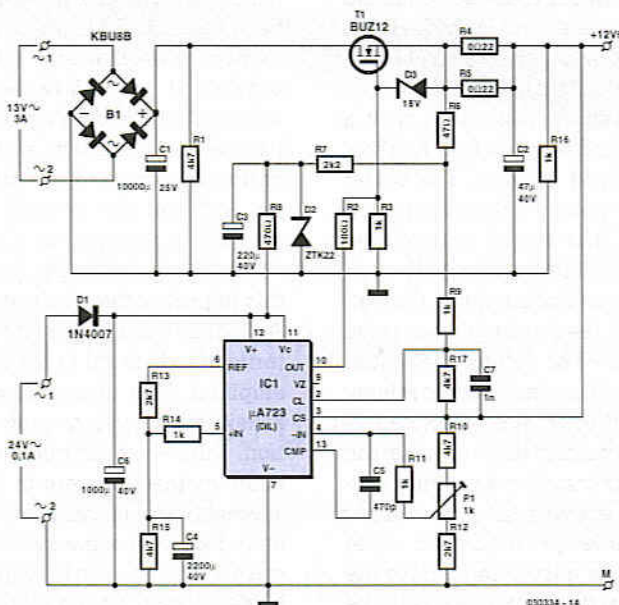


Figure 2. This low drop-out DC regulator provides the heater supply.

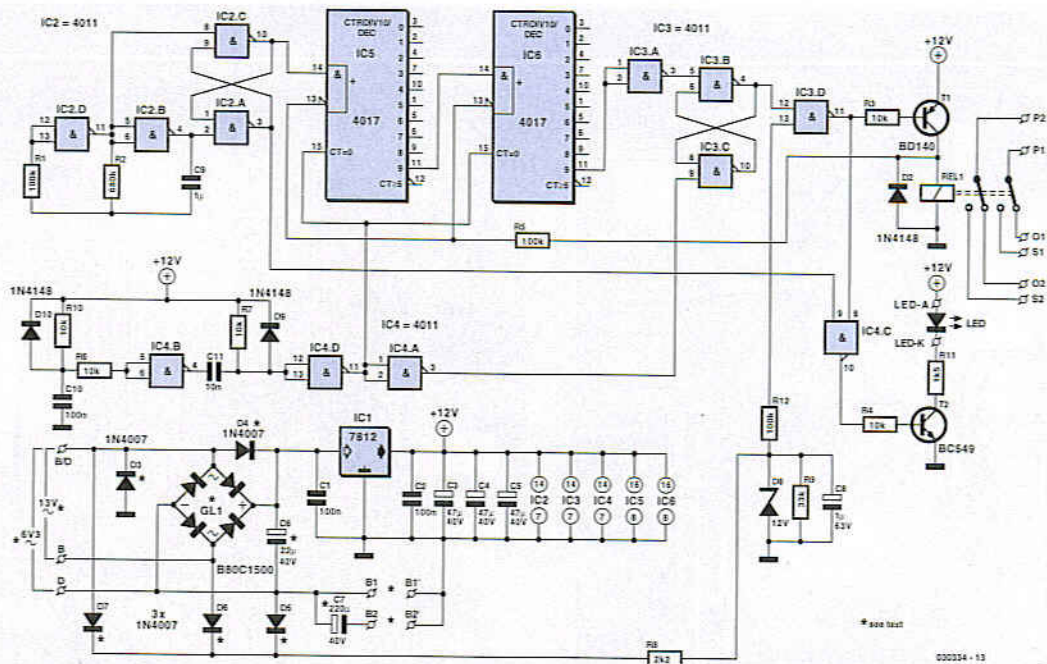


Figure 3. This clever switch-on delay circuit prevents clicks, hum and rumble.

about 0.6 V. Here, however, the base is provided with a stabilised bias voltage from temperature-compensated Zener diode D2 via R7 and R8. This results in a smaller voltage drop across R4 and R5 being needed to trigger current limiting.

The reference voltage produced by the 723 is divided down by R13 and R15. C4 is in principle necessary to filter out any noise on the reference voltage, but could be made considerably smaller. Because of the relatively high value of the capacitor, the voltage at pin 5 rises slowly, providing a 'soft start' to the heater supply. A BUZ12 FET with an  $R_{DS(on)}$  of just 28 m $\Omega$  is used for T1. It is important to ensure that the voltage difference between the cathode and the heater is not too high as otherwise arcing can occur. The negative side of the heater supply **must** therefore be connected to the negative side of the high voltage supply.

### Rattle and hum

When the output stage is switched on and while it is warming up the various reservoir and coupling capacitors may charge at different rates. This can give rise to hum and rumble. The circuit in **Figure 3** can suppress these sounds effectively. The normally-closed relay contact shorts out the output transformer for a set time (which the valve output stage can comfortably cope with). Only after a certain interval does

the relay pull in, removing the short circuit. This approach avoids putting transformer contacts in the signal path. The layout of the printed circuit board allows a relay with two changeover contacts to be fitted so that the circuit can be used for other applications, including with a stereo output stage. In our case the circuit runs from the 13 V heater supply, from which it will draw a maximum of 200 mA. If the switch-on delay circuit is to be connected to an existing amplifier, the circuit will work equally well from a 6.3 V heater supply winding, as long as there is sufficient spare current capacity. In this case a voltage doubler circuit is used. Depending on the choice of power supply voltage a number of components must be added to or removed from the circuit, as indicated on the component mounting plan and in the parts list.

### Switching on

When power is applied C8 immediately starts to charge via R8, taking the pin 13 input of IC3.D high. At the same time C10 charges via R10. As soon as the input threshold voltage of IC4.B is reached its output goes low and, via the high-pass network formed by C11 and R7, generates a brief low pulse at the input to IC4.D. This signal is inverted and then used to reset the 4017 counter to zero, and then inverted again and used to reset the flip-flop formed by IC3.B and IC3.C. The output

of this flip-flop at pin 4 thus goes low (if it was not already low). The output of IC3.D is consequently high, T1 does not conduct and the relay does not pull in. The output of the amplifier is therefore short-circuited.

IC2.B and IC2.D form a 1 Hz clock generator, the frequency being determined by C9 and R2. The flip-flop formed by IC2.A and IC2.B makes this clock available to the cascaded counters IC5 and IC6. After 100 counts the flip-flop comprising IC3.B and IC3.C is set via inverter IC3.A. The output of IC3.D then goes low, T1 conducts and the relay pulls in. The short-circuit is removed and the audio signal is now passed through to the loudspeaker. At the same time this high signal is used to disable counters via R5.

During the switch-on process the pin 8 input to IC4.C is high, and a 1 Hz signal is present on pin 9. The output on pin 10 will therefore also carry the 1 Hz signal, and so the LED flashes. Once the switch-on delay is complete pin 8 goes low, forcing the output of the NAND gate high. The LED now glows continuously.

### Switching off

When the amplifier is turned off, there is no longer any voltage present on the transformer. The transformer voltage is monitored continuously by D5 and D6 (13 V operation) or by D5 and D7 (6.3 V operation). If the voltage is not present,

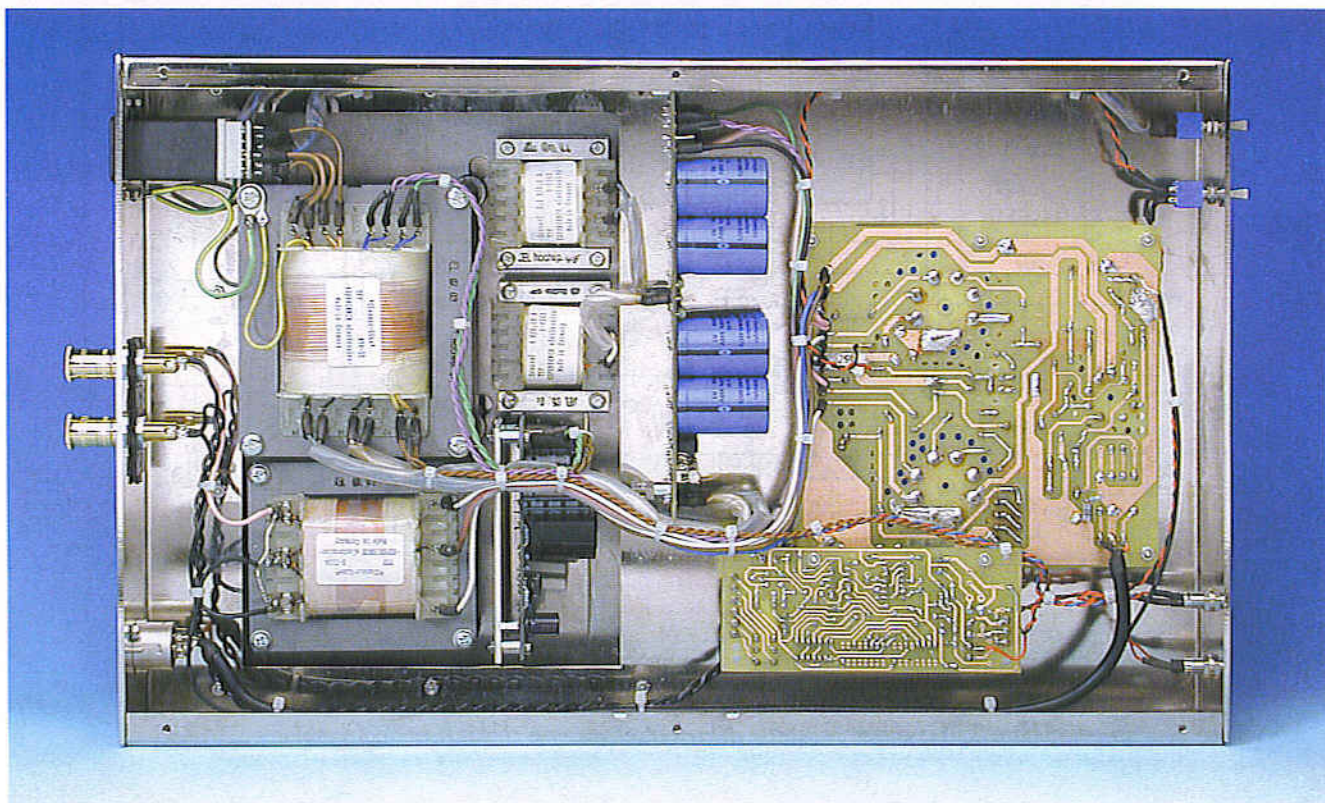


Figure 4. The amplifier seen from below.

the relay drops out immediately. Diodes D1 and D9 ensure that capacitors C10 and D11 discharge quickly. If power is applied again, the whole

cycle must be repeated. This ensures that the output is once again muted, ensuring that the unwanted effects mentioned earlier are avoided.

### Construction

The monoblock amplifier comprises a total of three printed circuit boards and several wound components fitted into

## A valve is a valve is a valve...

| Parameter                             | Symbol      | EL34    | EL156 | Units      |
|---------------------------------------|-------------|---------|-------|------------|
| Heater voltage                        | $U_f$       | 6.3     | 6.3   | V          |
| Heater current                        | $I_f$       | 1.5     | 1.9   | A          |
| Maximum anode voltage                 | $U_{amax}$  | 800     | 800   | V          |
| Maximum cathode current               | $I_{kmax}$  | 150     | 180   | mA         |
| Maximum anode power dissipation       | $P_{Vmax}$  | 25/27,5 | 40    | W          |
| Maximum screen grid power dissipation | $P_{vg2}$   | 8       | 8/12  | W          |
| Screen grid current                   | $I_{g2}$    | 11/22   | 5/25  | mA         |
| Maximum screen grid voltage           | $U_{g2max}$ | 425     | 450   | V          |
| in class AB operation                 |             | 425     | 350   |            |
| Grid bias voltage                     | $U_{g1}$    | -39     | -24   | V          |
| AC grid driving voltage               | $U_{g1AC}$  | 23      | 18    | V          |
| Transconductance                      | $S$         | 11      | 13    | mA/V       |
| Internal resistance                   | $R_i$       | 15      | 20    | k $\Omega$ |
| Maximum grid leak resistor            | $R_{g1max}$ | 700     | 100   | k $\Omega$ |

In some cases quantities have been rounded or guideline values shown, since not all data books exactly agree on all the figures. Values shown after an oblique are at maximum drive.

The EL34 and EL156 are genuine audio power pentodes rather than beam power tetrodes like the 6L6, KT88 or 6550. They are similar to one another, but not identical in all respects. The EL156 requires approximately 27 % more heater power, while offering a maximum cathode current about 20 % higher. Its maximum anode power dissipation is about 60 % higher than that of the EL34. The EL156 also features a higher internal resistance, higher

transconductance, higher current and slightly lower grid bias voltage. Maximum drive can also be obtained using a smaller grid



Figure 5. The comforting glow of an EL156 in action.

an enclosure as shown in **Figure 4**. Our prototype amplifier was housed in a seamlessly-welded nickel-plated aluminium enclosure polished to a glossy

finish. The use of aluminium provides shielding from magnetic interference which mostly originates in the fields produced by the transformers. All the

ground connections must be brought together at the amplifier board and bonded to the enclosure at a single point using a bolt and solder tag. If this

driving voltage. Because of these characteristics, greater gain can be achieved using the EL156 than with the EL34, and as a consequence we only need a double triode in the driver stage, despite our high output power.

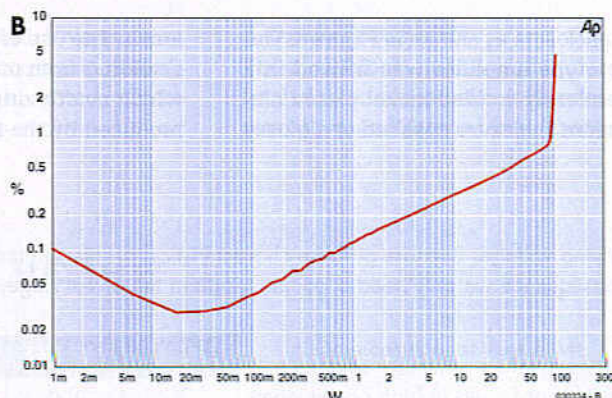
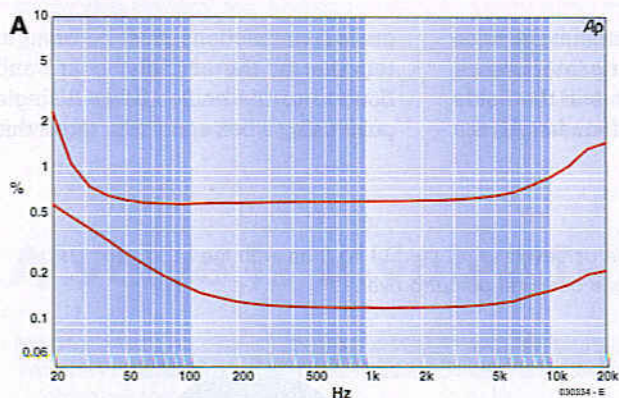
For both valves a number of details must be observed in high power operation. At higher supply voltages the screen grid voltage must be fixed at a given maximum value. It is also in general necessary to provide a fixed grid bias voltage. The maximum permitted grid leak resistor is considerably lower for the EL156 than for the EL34. The maximum value of the grid leak resistor is specified in the data sheet for each valve. In theory a valve can be driven without dissipating power, but in practice a small grid current flows which must be drained away. Account must be taken of this when designing the driver circuit. The EL156 can only be driven efficiently when the anode voltage is sufficiently high: power has its price! In a triode circuit using class AB push-pull operation dissipation can reach 30 W. The screen grid voltage for the EL156 in high power class AB push-pull operation must be at least 350 V; for the EL34 at least 400 V is required.



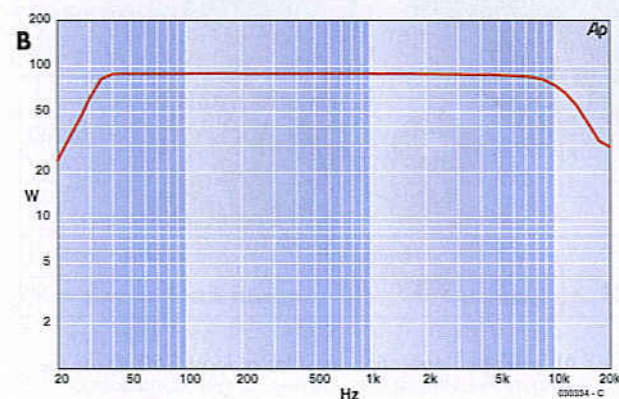
# On the test bench

**Measured characteristics** (all measurements taken with an 8  $\Omega$  load)

| Parameter   | Conditions                              |        | Value | Units            |
|---|---|--------|-------|------------------|
| Input sensitivity                                   | 90 W, 1 % THD+N                         |        | 1.4   | V <sub>eff</sub> |
| Input impedance                                     | 20 Hz                                   |        | 4     | k $\Omega$       |
|   | 1 kHz                                   |        | 9     |                  |
|   | 20 kHz                                  |        | 1.08  |                  |
| Sine wave output power                              | 1% THD+N                                |        | 90    | W                |
| Bandwidth   | -3 dB, 1 W                              |        | 41    | kHz              |
| Slew rate   | 10 $\mu$ s step                         |        | 5     | V/ $\mu$ s       |
| Signal-to-noise ratio                               | at 1 W,<br>bandwidth = 22 Hz to 22 kHz  |        | 88    | dB               |
|   |   |        | 102   | BA               |
| Harmonic distortion and noise over 80 kHz bandwidth | 1 W                                     | 1 kHz  | 0.12  | %                |
|   |   | 20 kHz | 0.21  |                  |
|   | 50 W                                    | 1 kHz  | 0.6   |                  |
|   |   | 20 kHz | 1.43  |                  |
| Intermodulation distortion                          | 50 Hz : 7 kHz = 4:1                     | 1 W    | 0.5   | %                |
|   |   | 50 W   | 2.6   |                  |
| Dynamic intermodulation distortion                  | 3.15 kHz square and<br>15 kHz sine wave | 1 W    | 0.064 | %                |
|   |   | 50 W   | 0.33  |                  |
| Damping factor                                      | 1 kHz<br>20 kHz                         | 2.9    | -     |                  |
|   |   | 2.3    |       |                  |

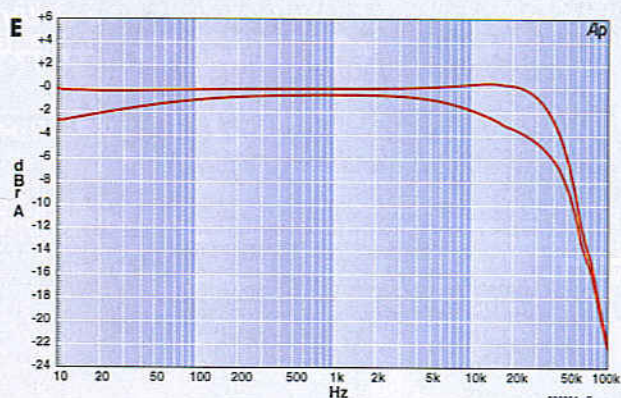
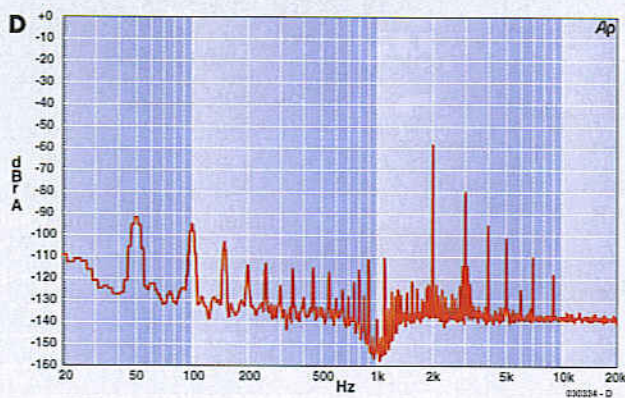


**Figure A** shows the total harmonic distortion plus noise (THD+N) as a function of frequency when the amplifier is driven at 1 W and at 50 W. The measurement was carried out using a bandwidth of 80 kHz. As is to be expected from a valve amplifier, the distortion increases as the core in the output transformer approaches saturation. This is not a particular disadvantage as the human ear is insensitive to low frequencies and does not find higher distortion levels unpleasant.



**Figure B** shows distortion as a function of drive level. The distortion rises from about 50 mW onwards, being dominated by harmonic components. The measurement was taken using a bandwidth from 22 Hz to 22 kHz in order to show more clearly the effect of harmonic distortion at low power levels. At 90 W the amplifier starts to clip.

**Figure C** shows the maximum power as a function of frequency for a fixed distortion (here 1%). The bandwidth used for the distortion measurement was 80 kHz. The maximum power starts to fall off towards the upper and lower ends of the amplifier's frequency range. At the upper end of the frequency range the situation is not too bad, since generally less power is required here anyway. Things are different below 40 Hz, where deep tones often demand a lot of power.



A spectrum analysis of the distortion to a 1 kHz sine wave signal at an output power of 1 W is shown in **Figure D**. Almost all the distortion is accounted for by the second harmonic at  $-58.3$  dB. The third harmonic lies at  $-80$  dB, and all the remaining harmonics, along with mains hum, are below  $-90$  dB. The hum component is mainly due to the magnetic field of the transformers (50 Hz component); otherwise the 100 Hz component would be expected to be much more significant.

Finally, **Figure E** shows the effect of the input circuit to the amplifier, where a  $4.7$  k $\Omega$  resistor and a  $2.2$  nF capacitor are effectively connected in parallel across the secondary side of the input transformer. If the output impedance of the preamplifier is greater than  $50$   $\Omega$ , the input impedance of the power amplifier has a clear effect. The upper curve shows the normal frequency response with an impedance of  $20$   $\Omega$ , while at  $600$   $\Omega$  the frequency response falls off markedly at both the upper and lower end of the frequency range.

is not done, the enclosure will act as an antenna and the amplifier will hum. The high voltages used mean that the enclosure **must** be earthed. Input and output connections must be isolated from the enclosure, or else stray earth currents may arise.

Cable with a cross-section of at least  $0.5$  mm<sup>2</sup> should be used between the relay contacts and the loudspeaker outputs. Thinner cables have too high a resistance, with the result that rumble can be heard faintly through the loudspeakers during the warm-up phase. The heater connections need cable with a cross-section of  $1.5$  mm<sup>2</sup>, the earth connections cable with a cross-section of  $0.75$  mm<sup>2</sup>, the high voltage connections cable with a cross-section of  $0.5$  mm<sup>2</sup>, and finally the auxiliary supply connections cable with a cross-section of  $0.25$  mm<sup>2</sup>.

Operation is relatively straightforward. First check again that all the components are mounted correctly and that the wiring is correct. Next check the auxiliary voltages, leaving out the fuse in the high voltage supply for now. When mains power is applied the negative grid bias voltage should immediately be present on the valve bases, and can be adjusted using the trimmer potentiometers. For the moment, set the voltage to its maximum negative value. Next check the heater voltage and adjust it to  $12.6$  V.

If voltage can be adjusted over a range of two to three volts, but the value of  $12.6$  V cannot be reached, then resistor R10 or R12 will need to be changed. Next fit the valves. Shortly, the heater filaments should start to glow, as shown in **Figure 5**.

We can now proceed to test the circuit with the high voltage present. It is absolutely essential that a load resistor rated to at least  $150$  W must **always** be connected. Do not forget to switch off the unit before fitting the high voltage supply fuse!

Turn the unit back on, and connect an oscilloscope across the load resistor to act as an output monitor. Once the warm-up phase is complete the quiescent current of the output valves can be set. Measure the voltage drop across each cathode resistor, R20 and R21, using a multimeter. Alternately adjust the currents through V2 and V3 for a voltage drop of  $450$  mV, which corresponds to  $45$  mA per valve. Next connect a signal generator producing a  $1$  kHz sinewave to the input, and gradually increase the amplitude of the signal. Observe the output signal on the oscilloscope. It should increase in amplitude without distortion or spurious oscillation until the point where it starts to clip. If the amplifier does have a tendency to oscillate, check that the

wiring is correct and that the earthing is sound. If the amplifier goes into large-amplitude oscillation as soon as it is switched on, which can be seen on the oscilloscope as a distorted squarewave with a frequency of approximately  $100$  Hz, and heard as a hum in the transformer and output valves, switch off immediately. The effect indicates that the output transformer has been connected with the wrong polarity, and anode 1 must be interchanged with anode 2, turning positive feedback into negative feedback. As long as the circuit is switched off immediately there should be no damage to the valves or other components.

(030334-1)

## Note

For reasons of space, printed circuit board layouts, component mounting plans and parts lists are only available in electronic form on the Internet, downloadable from

[www.elektor-electronics.co.uk](http://www.elektor-electronics.co.uk).

Ready-made unpopulated printed circuit boards and kits can be obtained from the author ([experience.electronics@t-online.de](mailto:experience.electronics@t-online.de)).

Visit our website  
www.distel.co.uk

# THE ORIGINAL SURPLUS WONDERLAND!

THIS MONTH'S SELECTION FROM OUR VAST EVER CHANGING STOCKS

Surplus always  
wanted for cash!

## GIANT 10" 7 SEGMENT DISPLAYS

A bulk purchase enables us to bring to you these GIANT 7 segment digital displays at a now affordable price! The 10" character size gives exceptional readability at long distances and enables a host of applications including score boards, digital clocks, counters, event timers etc. As the units are a simple electromechanical device and operate from 12V DC, simple switching via switches, relays, PIC or PC may be used to control single or multiple digits. Units feature integral 'Zero Power' memory which greatly simplifies design. For an excellent DIY practical article, see the May issue of 'Everyday & Practical Electronics' magazine. Ideal School / College construction project. Supplied in good RFE condition, complete with data sheet.



Less than 30%  
of makers price! Only £29.95(B) or 4 x £99.00(D)  
Order RW44 Order PH26

## THE AMAZING TELEBOX



TV SOUND &  
VIDEO TUNER  
CABLE COMPATIBLE\*

Converts your colour monitor into a QUALITY COLOUR TV!!

The TELEBOX is an attractive fully cased mains powered unit, containing all electronics ready to plug into a host of video monitors or AV equipment which are fitted with a composite video or SCART input. The composite video output will also plug directly into most video recorders, allowing reception of TV channels not normally receivable on most television receivers\* (TELEBOX MB). Push button controls on the front panel allow reception of 8 fully tuneable 'off air' UHF colour television channels. TELEBOX MB covers virtually all television frequencies VHF and UHF including the HYPERBAND as used by most cable TV operators. Ideal for desktop computer video systems & PIP (picture in picture) setups. For complete compatibility - even for monitors without sound - an integral 4 watt audio amplifier and low level Hi Fi audio output are provided as standard. Brand new - fully guaranteed.

TELEBOX ST for composite video input type monitors £36.95  
TELEBOX STL as ST but fitted with integral speaker £39.50  
TELEBOX MB Multiband VHF/UHF/Cable/Hyperband Tuner £69.95  
For overseas PAL versions state 5.5 or 6 mHz sound specification.  
\*For cable / hyperband signal reception Telebox MB should be connected to a cable type service. Shipping on all Teleboxes, code (B)

**NEW** State of the art PAL (UK spec) UHF TV tuner module with composite 1V pp video & NICAM hi fi stereo sound outputs. Micro electronics all on one small PCB only 73 x 160 x 52 mm enable full tuning control via a simple 3 wire link to an IBM pc type computer. Supplied complete with simple working program and documentation. Requires +12V & +5V DC to operate. **BRAND NEW - Order as MY00. Only £39.95 code (B)**  
See www.distel.co.uk/data\_my00.htm for picture + full details

## HARD DISK DRIVES 2 1/2" - 14"

2 1/2" TOSHIBA MK1002MAV 1.1Gb laptop (12.5 mm H) New £59.95  
2 1/2" TOSHIBA MK4313MAT 4.3Gb laptop (8.2 mm H) New £105.00  
2 1/2" TOSHIBA MK6403MAV 6.1Gb laptop (12.7 mm H) New £98.00  
2 1/2" TOSHIBA MK1814GAV 1.8Gb laptop (12 mm H) New £149.95  
2 1/2" to 3 1/2" conversion kit for PCs, complete with connectors £15.95  
3 1/2" COMPAQ 313702-B21 (IBM) 9 gb ULT/SCSI3 New £199.00  
3 1/2" FUJII FK-309-25 20mb MFH I/F RFE £59.95  
3 1/2" CONNER CP3024 20 mb IDE I/F (or equiv.) RFE £59.95  
3 1/2" CONNER CP3044 40 mb IDE I/F (or equiv.) RFE £69.00  
3 1/2" QUANTUM 40S Prodrive 42mb SCSI I/F, New RFE £49.00  
3 1/2" MINISCRIBE 3425 20mb MFH I/F (or equiv.) RFE £49.95  
5 1/4" SEAGATE ST-238R 30 mb RLL I/F Refurb. £69.95  
5 1/4" CD 94205-51 40mb HH MFM I/F RFE tested £69.95  
5 1/4" HP 97548 850 Mb SCSI RFE tested £99.00  
5 1/4" HP C3010 2 Gbyte SCSI differential RFE tested £195.00  
8" NEC D2246 85 Mb SMD interface. New £99.00  
8" FUJITSU M2322K 160Mb SMD I/F RFE tested £195.00  
8" FUJITSU M2322K 2 Gb SMD I/F RFE tested £345.00  
Many other floppy & H drives, IDE, SCSI, ESDI etc from stock, see website for full stock list. Shipping on all drives is code (C)

## TEST EQUIPMENT & SPECIAL INTEREST ITEMS

MITSUBISHI FA3445ETKL 14" Ind. spec SVGA monitors £24.45  
FARNELL 0-60V DC @ 50 Amps, bench Power Supplies £995  
FARNELL AP3080 0-30V DC @ 80 Amps, bench Supply £1850  
KINGSHILL CZ403/1 0-50V @ DC 200 Amps - NEW £3650  
1kW to 400 kW - 400 Hz 3 phase power sources - ex stock  
IBM 82300 Type 1, Token ring base unit driver £760  
Wayne Kerr RA200 Audio frequency response analyser £2500  
INFODEC U1, 24 port, RJ45 network patchpanels, #TH93 £49  
3COM 16670 12 Port Ethernet hub - RJ45 connectors #LD97 £69  
3COM 16671 24 Port Ethernet hub - RJ45 connectors £89  
3COM 16700 8 Port Ethernet hub - RJ45 connectors NEW £39  
IBM 53F5501 Token Ring ICS 20 port lobe modules £45  
IBM MAU Token ring distribution panel 6228-23-5050N £45  
AIM 501 Low distortion Oscillator 9Hz to 330KHz, IEEE I/O £550  
ALLGON 8360.1 1800-1880 MHz hybrid power combiners £250  
Trend DSA 274 Data Analyser with G703(2M) 64 I/O £90  
Marconi 6310 Programmable 2 to 22 GHz sweep generator £1550  
HP1650B 10kHz 1GHz-1GHz RF signal generator £3750  
HP1650B Logic Analyser £900  
HP3781A Pattern generator & HP3782A Error Detector £1800  
HP6621A Dual Programmable GPIB PSU 0-7 V 160 watts £475  
HP6264 Rack mountable variable 0-20V @ 20A metered PSU £475  
HP54121A DC to 22 GHz four channel test set £7900  
HP8130A opt 020 300 MHz pulse generator, GPIB etc £550  
HP A1, A0 8 pen HPGL high speed drum plotters - from HP DRAFTMASTER 1 8 pen high speed plotter £750  
EG+ Brookdeed 95035C Precision lock in amp £1800  
Keithley 590 CV capacitor / voltage analyser £3750  
Racal ICR40 dual 40 channel voice recorder system £4500  
Fiskers 45KVA 3 ph On Line UPS - New batteries £1499  
Emerson AP130 2.5KVA industrial spec UPS £2200  
Mann Tally MT645 High speed line printer £945  
Intel SBC 486/133SE Multibus 486 system, 8Mb Ram

# DISPLAY ELECTRONICS



## IC's - TRANSISTORS - DIODES

OBSOLETE - SHORT SUPPLY - BULK  
10,000,000 items EX STOCK  
For MAJOR SAVINGS  
CALL or see web site www.distel.co.uk

## COMPUTER MONITOR SPECIALS

Legacy products  
High spec genuine multisync.  
CGA, EGA, VGA, SVGA

Mitsubishi FA3415ETKL 14" SVGA Multisync colour monitor with fine 0.28 dot pitch tube and resolution of 1024 x 768. A variety of inputs allows connection to a host of computers including IBM PC's in CGA, EGA, VGA & SVGA modes, IBM, COMMODORE (including Amiga 1200), ARCHIMEDES and APPLE. Many features: Etched faceplate, text switching and LOW RADIATION MPR specification. Fully guaranteed, in EXCELLENT like used condition. Tilt & Swivel Base £475

VGA cable for IBM PC included. Only £129 (E) Order as CG73

External cables for other types of computers available - CALL

## Generic LOW COST SVGA Monitors

We choose the make, which includes Compaq, Mitsubishi, IBM, etc. Supplied ready to run with all cables, Standard RTB 90 day guarantee.

|                             |                             |                             |
|-----------------------------|-----------------------------|-----------------------------|
| 14"<br>£59.00<br>order TD84 | 15"<br>£69.00<br>order TG21 | 17"<br>£79.00<br>order TJ66 |
|-----------------------------|-----------------------------|-----------------------------|

Supplied in good used condition. Shipping code (D)

## VIDEO MONITORS

PHILIPS HCS35 (same style as CM8833) attractively styled 14" colour monitor with both RGB and standard composite 15.625 KHz video inputs via SCART socket and separate phono jacks. Integral audio power amp and speaker for all audio visual uses. Will connect direct to Amiga and Atari BBC computers. Ideal for all video monitoring / security applications with direct connection to most colour cameras. High quality with many features such as front concealed flap controls, VCR correction button etc. Good used condition - fully tested - guaranteed  
Dimensions: W14" x H12 1/4" x 15 1/2" D.  
Only £99.00 (B)

PHILIPS HCS31 Ultra compact 9" colour video monitor with standard composite 15.625 KHz video input via SCART socket. Ideal for all monitoring / security applications. High quality, ex-equipment fully tested & guaranteed (possible minor screen burns). In attractive square black plastic case measuring W10" x H10" x 13 1/2" D. 240 V AC mains powered.  
Only £79.00 (D)

## INDUSTRIAL COMPUTERS

Tiny shoebox sized industrial 40 Mhz 386 PC system measuring only (mm) 266 x X 88 x X 272 d. Ideal for dedicated control applications running DOS, Linux or even Windows! Steel case contains 85 to 265 V AC 50 / 60 Hz 70 Watt PSU, a 3 slot ISA passive backplane and a Rocky 318 (PC104) standard, single board computer with 8 MByte NON VOLATILE solid state 'Disk On Chip' RAMDISK. System comprises: Rocky 318 (PC104) SBC ISA card with 40MHz ALI 386SX CPU, 72 pin SIMM slot with 16 MByte SIMM, AMI BIOS, battery backed up real time clock. 2 x 9 pin D 16550 serial ports, EPP/ECP printer port, mini DIN keyboard connector, floppy port, IDE port for hard drives up to 528 MByte capacity, watchdog timer and PC/104 bus socket. The 8 MByte solid state 'disk on chip' has its own BIOS, and can be formatted, formatted & booted. Supplied BRAND NEW fully tested and guaranteed. For full data see featured item on website. Order as QG36  
100's of applications inc: firewalls, routers, robotics etc  
Only £99.00 (D)

## 19" RACK CABINETS

Europe's Largest Stocks of  
quality rack cabinets,  
enclosures and accessories.  
Over 1000 Racks from stock

This month's special  
33 / 42 / 47 U - High Quality  
All steel Rack Cabinets

Made by Eurocraft Enclosures Ltd to the highest possible spec, rack features all steel construction with removable side, front and back doors. Front and back doors are hinged for easy access and all lockable with five secure 5 lever barrel locks. The front door is constructed of double walled steel with a 'designer style' smoked acrylic front panel to enable status indicators to be seen through the panel, yet remain unobtrusive. Internally the rack features fully slotted reinforced vertical fixing members to take the heaviest of 19" rack equipment. The two movable vertical fixing struts (extras available) are pre-punched for standard 'cage nuts'. A mains distribution panel internally mounted to the bottom rear, provides 8 x IEC 3 pin Euro sockets and 1 x 13 amp 3 pin switched utility socket. Overall ventilation is provided by fully louvered back door and double skinned top section with top and side louvers. The top panel may be removed for fitting of integral fans to the sub plate etc. Other features include: fitted castors and floor levelers, pre-punched utility panel at lower rear for cable / connector access etc. Supplied in excellent, slightly used condition with keys. Colour Royal blue, some grey available - CALL - Can be supplied in many other configurations.



|   |   |   |
|---|---|---|
| 33U<br>Order as BC44<br>External dimensions<br>mm=1625H x 635D x<br>603 W. (64" H x 25"<br>D x 23 3/4" W)<br>Only<br>£245 | 42U<br>Order as DT20<br>External dimensions<br>mm=2019H x 635D x<br>603 W. (79.5" H x 25"<br>D x 23 3/4" W)<br>Only<br>£345 | 47U<br>Order as RV36<br>External dimensions<br>mm=2235H x 635D x<br>603 W. (88" H x 25"<br>D x 23 3/4" W)<br>Only<br>£410 |
|---|---|---|

Call for shipping quotation

## COLOUR CCD CAMERAS

Undoubtedly a miracle of modern technology & our special buying power! A quality product featuring a fully cased COLOUR CCD camera at a give away price! Unit features full auto light sensing for use in low light & high light applications. A 10 mm fixed focus wide angle lens gives excellent focus and resolution from close up to long range. The composite video output will connect to any composite monitor or TV (via SCART socket) and most video recorders. Unit runs from 12V DC so ideal for security & portable applications where mains power not available. Overall dimensions 66 mm wide x 117 deep x 43 high. Supplied BRAND NEW & fully guaranteed with user data, 100's of applications including Security, Home Video, Web TV, Web Cams etc, etc.  
Order as LK33 ONLY £79.00 or 2 for £149.00 (B)



## SOFTWARE SPECIALS

NT4 WorkStation, complete with service pack 3 and licence - OEM packaged. ONLY £89.00 (B)  
ENCARTA 95 - CDROM, Not the latest - but at this price! £7.95  
DOS 5.0 on 3 1/2" disks with concise books o/w QBasic £14.95  
Windows for Workgroups 3.11+ Dos 6.22 on 3 1/2" disks £55.00  
Windows 95 CDROM Only - No Licence - £19.95  
Wordperfect 6 for DOS supplied on 3 1/2" disks with manual £24.95  
shipping charges for software is code B

## SOLID STATE LASERS

Visible red, 670nm laser diode assembly. Unit runs from 5 V DC at approx 50 mA. Originally made for continuous use in industrial barcode scanners, the laser is mounted in a removable solid aluminium block, which functions as a heatsink and rigid optical mount. Dims of block are 50 w x 50 d x 15 h mm. Integral features include over temperature shutdown, current control, laser OK output, and gated TTL ON / OFF. Many uses for experimental optics, comms & lightshows etc. Supplied complete with data sheet.  
Order as TD91 ONLY £24.95 (A)

## DC POWER SUPPLIES

Virtually every type of power supply you can imagine. Over 10,000 Power Supplies  
Ex Stock - Call or see our web site.

## RELAYS - 200,000 FROM STOCK

Save ££££'s by choosing your next relay from our Massive Stocks covering types such as Military, Octal, Cradle, Hermetically Sealed, Continental, Contactors, Time Delay, Reed, Mercury Wetted, Solid State, Printed Circuit Mounting etc. CALL or see our web site www.distel.co.uk for more information. Many obsolete types from stock. Save ££££'s

ALL MAIL TO  
Dept EK, 29 / 35 Osborne Rd  
Thornton Heath  
Surrey CR7 8PD, UK  
Open Mon - Fri 9.00 - 5:30

18 Million Items On Line Now!  
Secure Ordering, Pictures, Information  
www.distel.co.uk  
email = admin@distel.co.uk

ALL ENQUIRIES  
0208 653 3333  
FAX 0208 653 8888

All prices for UK Mainland. UK customers add 17.5% VAT to TOTAL order amount. Minimum order £10. Bona Fide account orders accepted from Government, Schools, Universities and Local Authorities - minimum account order £100. Cheques over £100 are subject to 7 working days clearance. Carriage charges (A)=£3.50, (B)=£6.50, (C)=£10, (D)=£15.00, (E)=£18.00, (F)=CALL. Allow approx 3 days for shipping - faster CALL. All goods supplied to our Standard Conditions of Sale which can be viewed at our website and unless stated guaranteed for 90 days. All guarantees on a return to base basis. All rights reserved to change prices / specifications without prior notice. Orders subject to stock. Discounts for volume. Top CASH prices paid for surplus goods. All trademarks, tradenames etc acknowledged. © Display Electronics 2002. E & O E.

# PicoScope 3000 Series PC Oscilloscopes

The PicoScope 3000 series oscilloscopes are the latest offerings from the market leader in PC oscilloscopes combining high bandwidths with large buffer memories. Using the latest advances in electronics, the oscilloscopes connect to the USB port of any modern PC, making full use of the PCs' processing capabilities, large screens and familiar graphical user interfaces.



- High performance: **10GS/s** sampling rate & **200MHz** bandwidth
- **1MB** buffer memory
- High speed **USB 2.0** interface
- Advanced display & trigger modes
- Compact & portable
- Supplied with PicoScope & PicoLog software

| PicoScope                   | 3204                       | 3205                    | 3206                    |
|-----------------------------|----------------------------|-------------------------|-------------------------|
| Bandwidth                   | 50MHz                      | 100MHz                  | 200MHz                  |
| Sampling rate (sequential)  | 2.5GS/s                    | 5GS/s                   | 10GS/s                  |
| Sampling rate (single shot) | 50MS/s                     | 100MS/s                 | 200MS/s                 |
| Channels                    | 2 + Ext trigger            | 2 + Ext trigger/Sig gen | 2 + Ext trigger/Sig gen |
| Oscilloscope timebases      | 5ns/div to 50s/div         | 2ns/div to 50s/div      | 1ns/div to 50s/div      |
| Timebase accuracy           | 50ppm                      | 50ppm                   | 50ppm                   |
| Spectrum ranges             | 0 to 25MHz                 | 0 to 50MHz              | 0 to 100MHz             |
| Buffer memory size          | 256KB                      | 512KB                   | 1MB                     |
| Resolution / accuracy       | 8 bits / 3%                |                         |                         |
| Ranges                      | ±100mV to ±20V             |                         |                         |
| PC Connection               | USB2.0 (USB1.1 compatible) |                         |                         |

Tel: 01480 396395

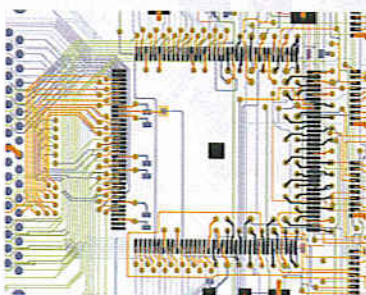
[www.picotech.com/scope251](http://www.picotech.com/scope251)

**pico**  
Technology Limited

**No1** Number One Systems

**Easy-PC** for Windows

The world beating PCB design software



## Easy-PC version 8 is released

Winning accolades the world over, Easy-PC for Windows V8 is a major milestone in the evolution of this extremely popular software tool. Try a demonstration copy of Easy-PC and prepare to be amazed at the power, versatility and remarkable value for money.

STILL FROM ONLY  
**£97**  
PLUS VAT

### New in Version 8

- Sketch Mode Routing
  - ODB++ Format Export
  - Import Bitmap
  - Single-Sided AutoRoute
  - Customisable Toolbars
  - Auto Smooth & Mitring of tracks
  - Wires & Jumpers
  - Unified Quality Check
- Plus lots more.....

Fully integrated Schematics & PCB layout in a single application complete with forward and back annotation. Design and rules checks at all stages ensure integrity at all times. Professional manufacturing outputs allow you to finish the design process with ease.

**Stop press... Stop press... Stop press... Stop press... Stop press...**  
By customer demand now with Eagle import as well as Tsien Boardmaker 2 import.

call for a brochure, prices & CD on +44 (0) 1684 773662  
or e-mail [sales@numberone.com](mailto:sales@numberone.com)  
you can also download a demo from

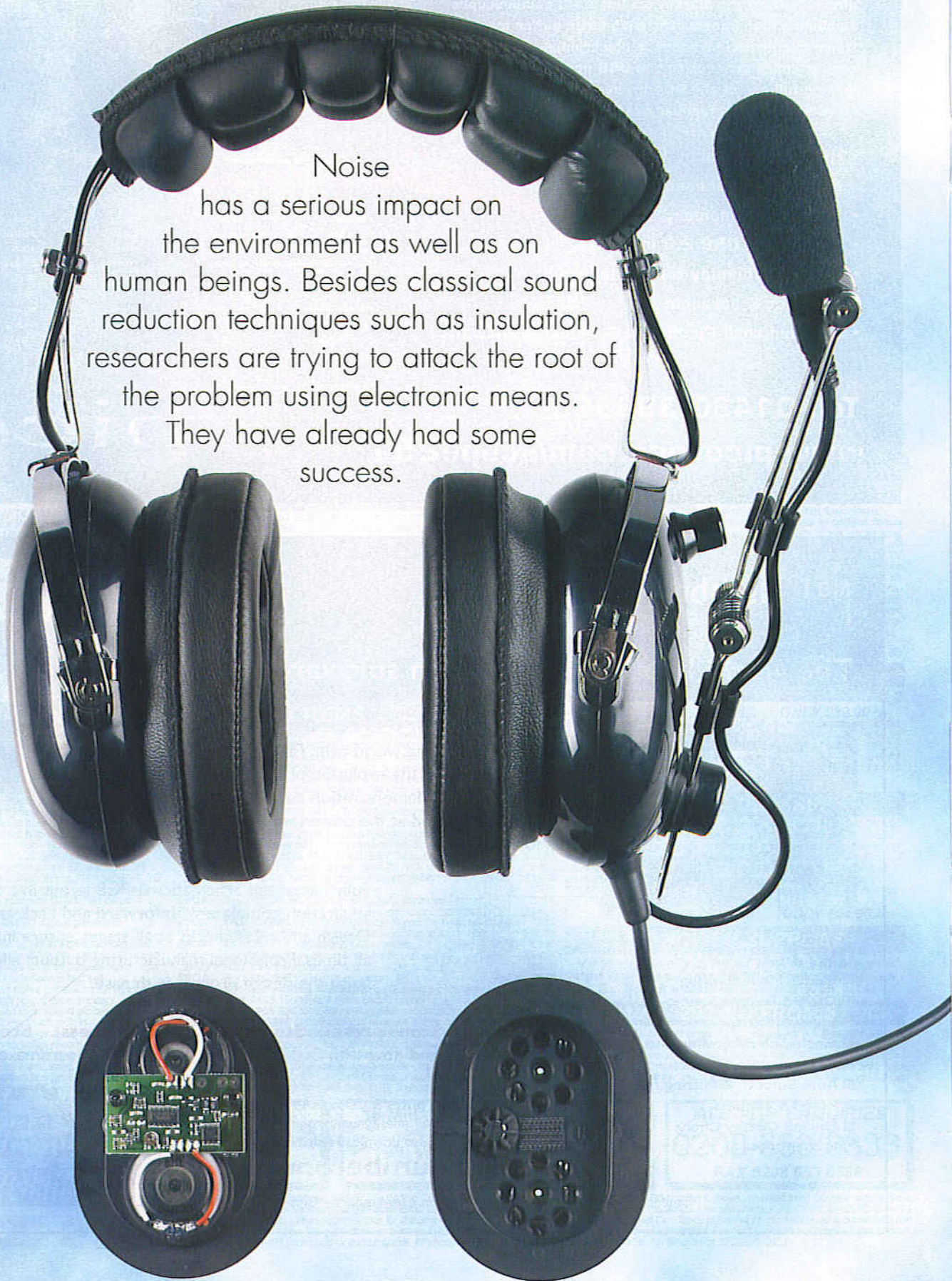
[www.numberone.com](http://www.numberone.com)



Number One Systems - Oak Lane - Bredon - Tewkesbury - Glos - United Kingdom - GL20 7LR UK

# ANTI-NOISE

Noise has a serious impact on the environment as well as on human beings. Besides classical sound reduction techniques such as insulation, researchers are trying to attack the root of the problem using electronic means. They have already had some success.



# The sound of silence

Sometimes it happens that an underlying physical process is well understood on paper, but the job of translating the theory into the real world takes a long time. One example of this is the patent awarded to the German physicist Paul Lueg in 1933. His idea was astonishingly simple and elegant. In his original patent document (Figure 1) he describes how an incoming sound wave can be detected using a microphone, converted to an electrical signal, given a 180° phase shift, and mixed with the original signal using a loudspeaker. The result is silence (Figure 2). Well, at least in theory the result is silence; the frequency response of the microphone, loudspeaker and electronics along with other effects such as temperature and humidity mean that in practice things are harder than that.

## Anti-noise in headphones

Noise has a serious impact on the environment as well as on human beings. It causes tiredness, loss of concentration, nervousness and irritability, and can lead to permanent hearing damage. Passive ear protection reduces noise especially in the middle and upper frequency ranges, but is not adequate at lower frequencies (Figure 3).

Is it possible to use Paul Lueg's patent in the battle against noise? Indeed it is: the most widespread and well-known application is in air travel, where active noise compensation is used in headphones for crew and passengers (first class only, of course!). The system is known as ANR (active noise reduction) or ANC (active noise cancellation). In the USA at least, there is considerable consumer demand for ANR headphones to allow music to be heard undistorted in noisy surroundings. The market fulfils this demand, with units available from thirty dollars from such well-known brands as Philips, Sony, Aiwa, Maxell, Bose, Shure, Koss, Altec-Lansing and Jensen. Panasonic also offers in-ear headphones with ANR. Sennheiser ([www.sennheiser.com](http://www.sennheiser.com)) is among the leading suppliers of headsets and headphones featuring ANR, with their NoiseGard™ system. An electret microphone capsule is fitted in each headphone unit, along with a negative-feedback circuit and a transducer system. The sound received by the microphone, which includes the wanted signal as well as the interference, is amplified and the wanted signal filtered out. The interference signal is processed, phase shifted by 180°, and added to the wanted signal. The result is sent to the transducer system. Superimposing the anti-phase signal considerably reduces the amplitude of the interference, whereas the wanted signal, which has not passed through the compensation circuit, is unaffected.

NoiseGard™ headsets and headphones are available in closed and open versions. The open versions are suitable for compensating for the noise level and spectrum found in business jets or commercial aeroplanes. More than 10 dB of compensation is achieved over the range from 400 Hz to 1000 Hz (Figure 4). This allows the

June 9, 1936. P. LUEG 2,043,416  
PROCESS OF SILENCING SOUND OSCILLATIONS  
Filed March 8, 1934

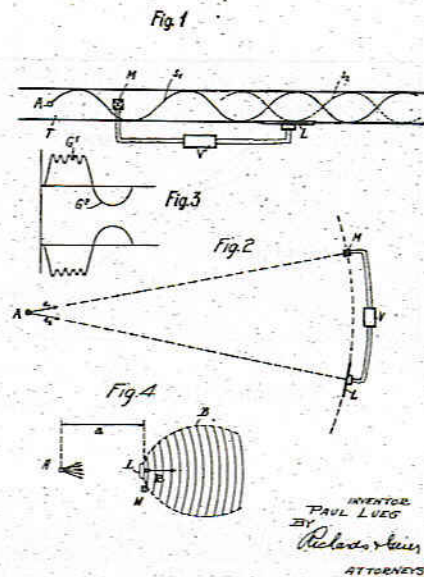


Figure 1. Facsimile of the patent document by Paul Lueg.

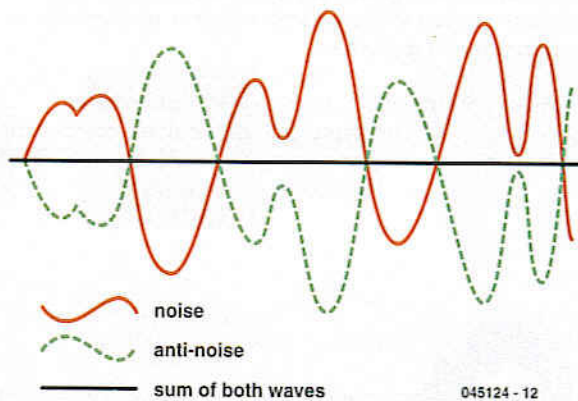


Figure 2. How anti-noise systems work (but sadly, only in theory!)

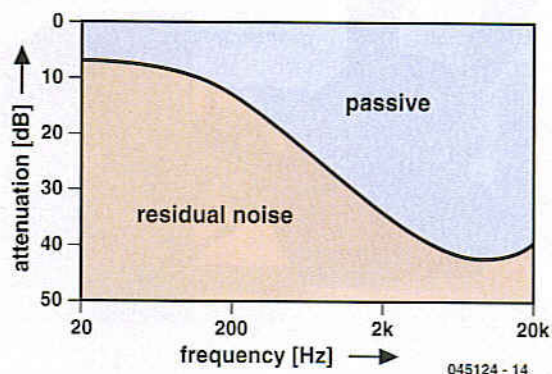


Figure 3. Attenuation in closed headphones without ANR.

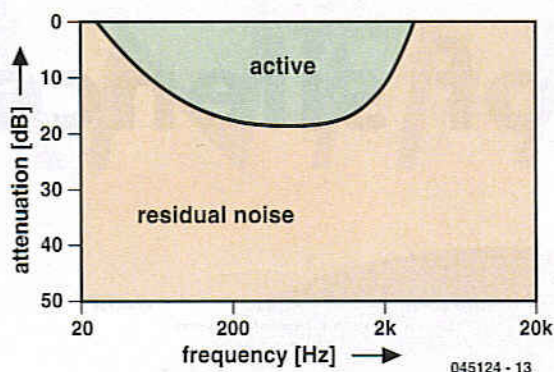


Figure 4.  
An active system with open headphones works particularly well in the middle frequency range.

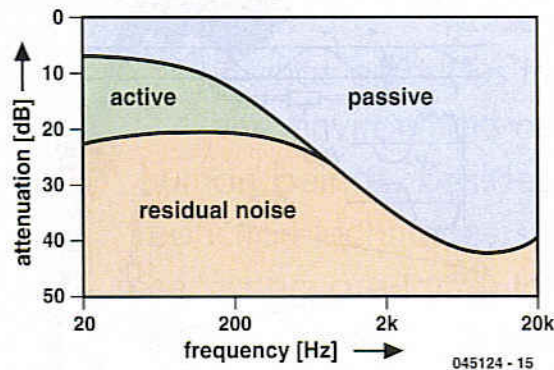


Figure 5.  
With closed headphones ANR also attenuates the lower frequencies.

volume level of speech radio communications to be reduced, without compromising their intelligibility. Thanks to the open form of the headphones, voices and alarm signals in the cockpit can be heard practically without distortion. Noise, on the other hand, is considerably attenuated. Lightweight open headphones offer excellent comfort to the wearer, which is particularly important for long journeys.

If passive ear protectors, such as earplugs or closed headphones, are combined with active noise compensation, noise in the frequency range from 25 Hz to 500 Hz



Figure 6.  
Typical low-cost ANR headphones for listening to music in noisy environments. The electronics box is connected to the signal source (personal stereo etc.) and linked to the headphones, which also include two microphones, using an 8-core screened cable.

can be attenuated by more than 25 dB (Figure 5). The total effect of active and passive noise compensation is around 30 dB over the entire audio spectrum. Closed systems are particularly suitable for aircraft with a high noise level in the cockpit, such as helicopters and military aircraft, as well as for most propeller aircraft. These closed systems can be retrofitted with ANR kits to add active noise compensation. The picture at the beginning of the article shows a headset together with an ANR module from an ANR kit. As can be seen from the photograph, each module consists of two headphone loudspeakers with an electret microphone capsule positioned between the two loudspeakers. On the rear side of the module is a printed circuit board carrying SMD components. On closer inspection, the two ICs reveal themselves to be a TL064C (quad FET opamp) and an MC34119 (low power audio amplifier). Superficially the circuit looks like a relatively simple analogue ANR circuit, but tests and experience show that it is highly effective. Kits of this type are available from outlets dealing in aircraft equipment. The modules and headset pictured are available from BÜSCHER-FLUGVERSAND, 43466 WOLFHAGEN, Germany ([www.flugversand.de](http://www.flugversand.de), website in German only).

## Active noise control

In the applications of noise compensation that we have described the spatial volume over which noise is reduced is narrowly limited. Under these conditions ANC is at its most effective. In larger spaces and in the open air it is

## Anti-noise online

We looked at the specialist headphones website **HeadWize** in our 'Electronics Online' feature in the October 2003 issue of *Elektor Electronics*. This site is a rich source of information on ANR headphones. As well as an article on the various **basic principles** of operation [1] that is well worth reading, there is also a complete guide to constructing an analogue **ANR circuit** [2].

Somewhat more complex is the DSP **application note** 'Adaptive Active Noise Control for Headphones Using the TMS320C30 DSP' by Texas Instruments [3].

A good overview of the subject, including lots of information, ideas and links can be found on the ANC pages by **Signal Systems Corp.** [4] and the ANC FAQ site by **Christopher E. Ruckman** [5]. **Edge Consulting Group** [6] offers a **news site** for acoustics, vibrations and signal processing with a page on 'Active Noise Control'.

Anyone considering adding an **ANR kit** to a passive headset will find detailed information at **ANR-Headsets.com** [7] and **Headsets Inc.** [8].

### Web addresses:

- [1] [http://headwize.com/tech/anr\\_tech.htm](http://headwize.com/tech/anr_tech.htm)
- [2] [http://headwize.com/projects/showfile.php?file=noise\\_prj.htm](http://headwize.com/projects/showfile.php?file=noise_prj.htm)
- [3] [www.s.ti.com/sc/psheets/spra160/spra160.pdf](http://www.s.ti.com/sc/psheets/spra160/spra160.pdf)
- [4] [www.signalsystemscorp.com/ancindex.htm](http://www.signalsystemscorp.com/ancindex.htm)
- [5] <http://users.erols.com/ruckman/ancfaq.htm>
- [6] [www.ecgcorp.com/](http://www.ecgcorp.com/)
- [7] [www.anr-headsets.com/](http://www.anr-headsets.com/)
- [8] [www.headsetsinc.com/](http://www.headsetsinc.com/)

much harder to achieve noise compensation. There has, however, been some progress in this direction. In aviation, noise compensation has been used in the cockpit since the mid-90's, especially in turboprop aircraft and, more recently, in a business jet. The first commercial aircraft to be fitted with such a system is the Swedish Saab 2000. The system, by Ultra Electronics Ltd. ([www.ultraquiet.com](http://www.ultraquiet.com)), uses 72 microphones in the cabin to continuously analyse the noise spectrum. A powerful micro-processor system processes the signals and generates a phase-shifted correction signal that is emitted through 36 loudspeakers. ANC is particularly useful for reducing propeller noise. A similar application area is reducing the noise produced by large ventilation fans in climate control equipment. Industrial motors can also be equipped with ANC. In the automotive sector ANC is still at the research stage, but it would of course be interesting to be able to exploit the existing loudspeaker arrangements.

It would make more sense to try actively to reduce the noise at the point of production rather than at the receiver. This is an area of current research, but the practical results have so far been few. **Figure 7** shows the construction of a research project at the German Aerospace Centre aimed at reducing the noise from an aircraft engine turbine. Experts calculate that a reduction of between 10 dB and 20 dB in noise level can be achieved. This corresponds to between one half and one quarter of the original volume.

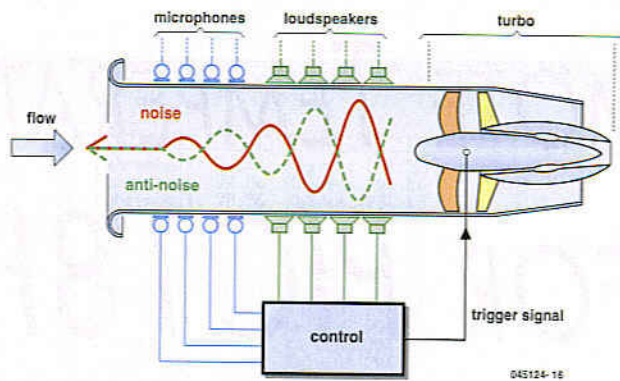


Figure 7. Active noise control at source: research at the German Aerospace Centre.

The ANC anti-noise technique can be applied not only to noise, but also to vibration. The techniques of AVC (active vibration control) and ASAC (active structure acoustic control), which aims to reduce noise produced as a result of vibration, look to have a bright future.

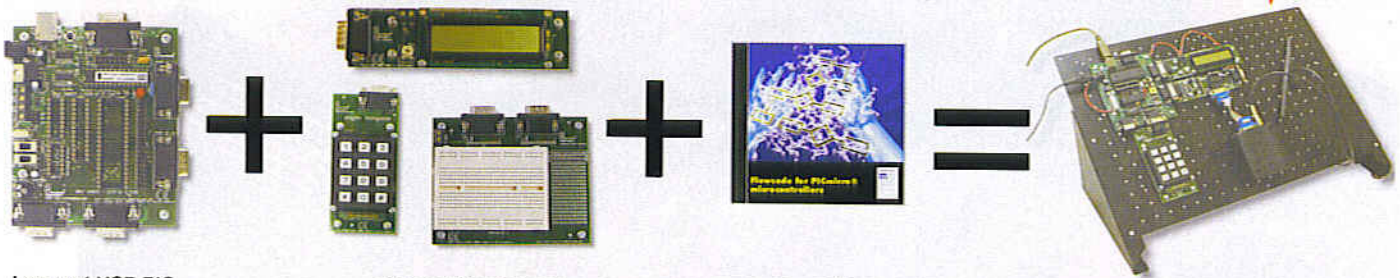
(040440-1)

Advertisement

## For rapid development of electronic systems...

**E-BLOCKS™**

E-blocks are small circuit boards each of which contains a block of electronics typically found in an electronic system. E-blocks can be programmed in C, Assembly and are tightly integrated with Flowcode - which instantly converts flow charts into PICmicro code.



Low cost USB PIC programmers  
(Starting at £27, model shown £65)

..plus a wide range of add-on boards and accessories...

.....plus incredibly easy to use software based on flow charts...

...equals extremely rapid system development: like this mobile text messaging system built from E-blocks.

## ...and solutions for learning and development...

Hands on training courses



training courses in PICmicro(R) programming, CPLD programming and ECAD

Resources for learning CPLD programming



Complete courses in electronics and programming



Equipment for datalogging, control and PC 'scopes



...and more at:



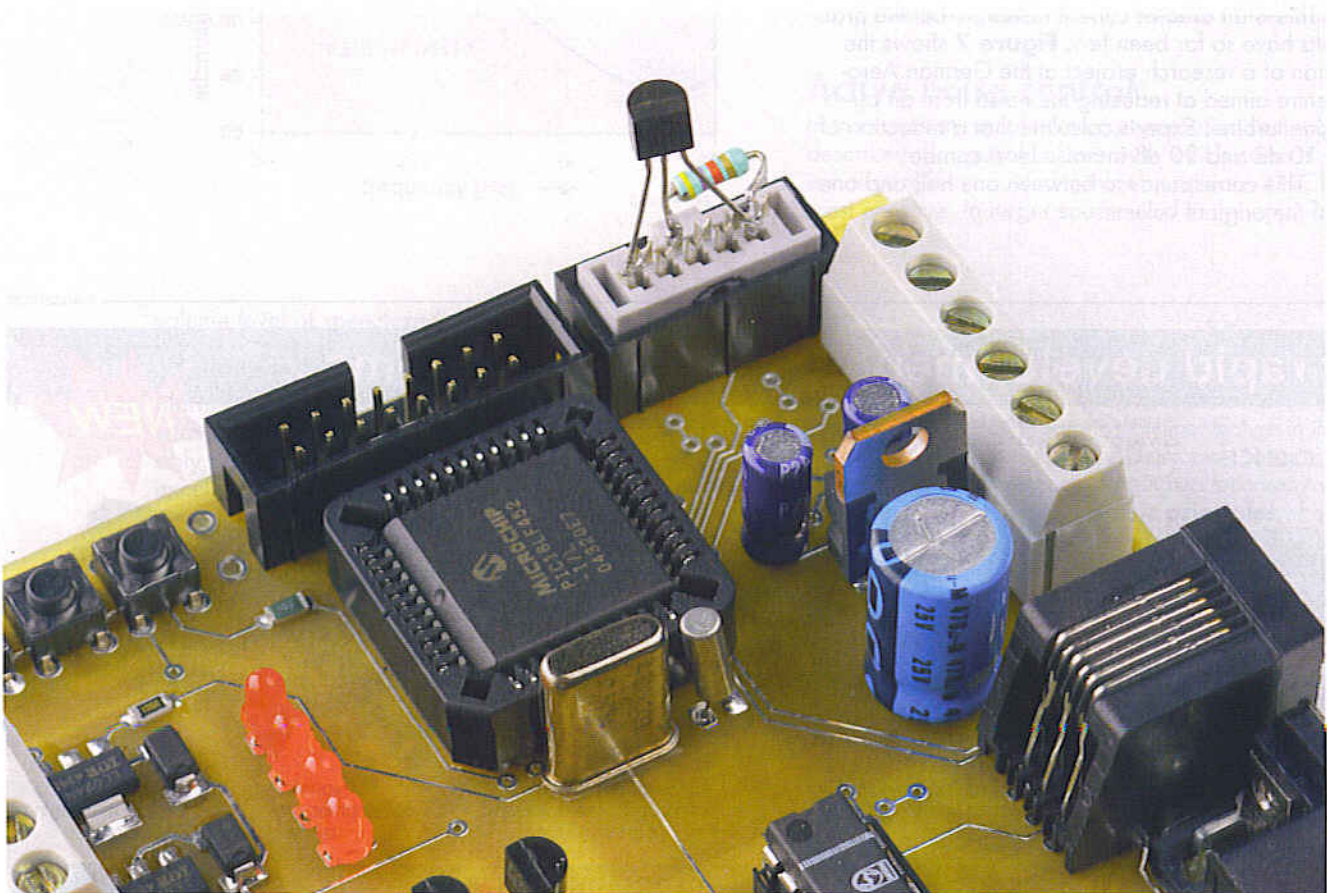
...see [www.matrixmultimedia.co.uk](http://www.matrixmultimedia.co.uk)

Matrix Multimedia Limited  
sales@matrixmultimedia.co.uk  
t. 0870 700 1831 f. 0870 700 1832

# REMOTE TEMPERATURE LOGGER FOR PIC18F BOARD

Using a DS1820 1-wire temperature sensor

Peter Moreton



In this short article, we describe how to bit-bang a DS18B20 or DS18S20 temperature sensor device using PIC firmware written in 'C', and output the temperature values to the RS232 port, for logging on a PC, all using the PIC18Flash Development Board published last month.

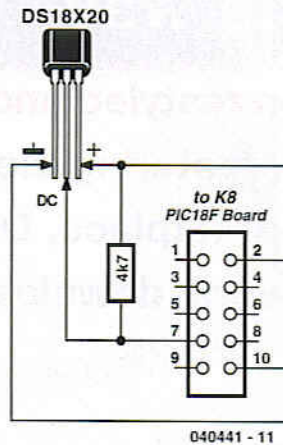


Figure 1. Circuit diagram of the Remote Temperature Logger hardware — all parts are connected to K8 on the PIC18F Flash Development Board.

The PIC18Flash development board described in *Elektor Electronics* January 2005 includes a header 'K8' that delivers the appropriate processor pins for SPI / Microwire, I<sup>2</sup>C and 1-Wire communications to external devices. The SPI/Microwire and I<sup>2</sup>C protocols are supported by dedicated PIC hardware modules, and are quite easy to use as the hardware can be accessed using standard C18 library functions.

The Dallas/Maxim '1-Wire' bus does not benefit from a dedicated PIC hardware module and therefore must be implemented by 'bit-banging' the appropriate MCU pin high and low in accordance with the 1-Wire protocol specification.

## The 1-Wire bus

The Dallas / Maxim 1-Wire bus uses a single data line (hence '1-Wire') to transmit and receive data. Each 1-Wire device must also be connected to a common ground, and optionally to a power supply. If the power supply line is omitted, the 1-Wire device can be 'parasitically powered' from the data line. The 1-Wire bus is normally held 'high' using a 4k7 resistor to V<sub>dd</sub>, and the devices pull the bus low and release the bus to go high, in order to signal data bits.

Pin RA4 of the PIC18F452 is particularly suited to the 1-wire protocol, as it

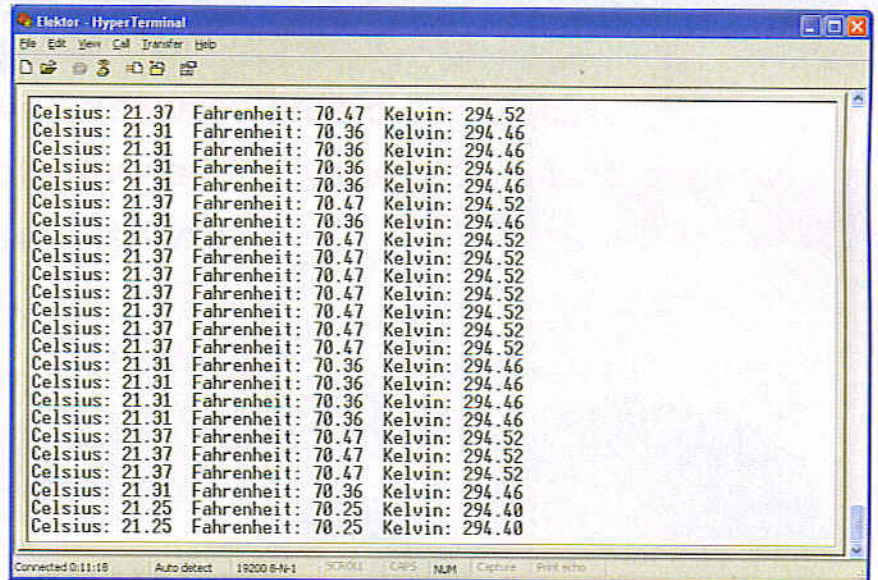


Figure 2. Screenshot showing the Temperature Logger software in action.

is an open-drain pin, enabling the bus to be 'released', and pulled high by the 4k7 bus pull-up.

The bus protocol works by defining a number of signal types: a reset pulse, presence pulse, write 0, write 1, read 0 and read 1. Each signal has timing parameters which must be strictly adhered to, and therefore an attribute of all 1-wire systems is the ability to generate accurate 'time-slots'. Readers wishing to fully understand 1-Wire signalling are referred to the in-depth documentation available from the Dallas/Maxim website.

## DS18x20 Temperature Sensors

There are a number of similar devices in the DS1820 lineup; we have developed and tested PIC firmware for the DS18S20 giving 9-bits / 0.5 DegC resolution and the DS18B20 giving up to 12 bits/0.0625 DegC resolution. Both parts are accurate to within 0.5 DegC.

Either device may be used, by editing the DS1820.C source file appropriately to call one of the two available functions:

```
Celsius =
Read_Temperature_DS18S20();
// use DS18S20 device
```

or

```
Celsius =
Read_Temperature_DS18B20();
// use DS18B20 device
```

The pre-compiled HEX file included in the free download for this article (no. 040441-11.zip) assumes the higher resolution DS18B20 device is connected.

## Circuit Description

Figure 1 shows a Dallas DS18S20 or DS18B20 temperature sensor in a TO92 package and a 4k7 pull-up resistor connected to the K8 header, as follows:

- K8 pin 2 to DS1820 pin 3, V<sub>dd</sub>;
- K8 pin 10 to DS1820 pin 1, Ground;
- K8 pin 7 to DS1820 pin 2, DQ;
- Fit a 4k7 pull-up between DQ and V<sub>dd</sub>.

It is acceptable to extend the interconnecting cable up to several meters to allow for remote measurement, and we suggest that for external applications the DS1820 be protected from the elements using heatshrink tubing over a waterproof sealant.

(040441-1)

# elektor

electronics • leading the way

Elektor's online services have been restyled and extended within a brand new easy to use website. Now featuring Elektor News Service, Forum, Marketplace, Online Shop and several download options.



restyled and extended

## MAGAZINE

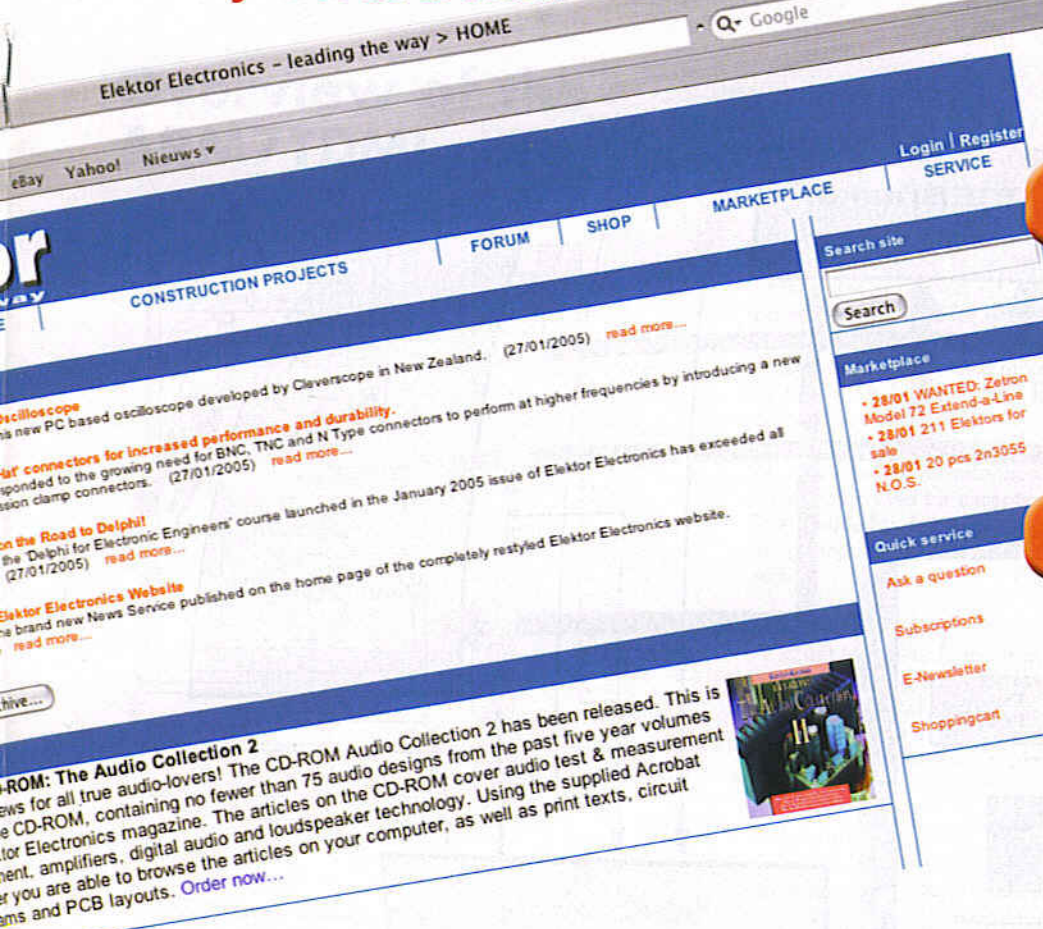
- indexed article archive back to 1998
- summary for easy recognition
- search articles by volume or keyword

[www.elektor-el](http://www.elektor-el)

register a

- on paper and on the web

**Definitely worth a visit!**



**electronics.co.uk**

**and receive the free E-Newsletter!**

## NEWS

- daily electronics newfeed
- weekly free Newsletter

## FORUM

- join in discussions with fellow enthusiasts and specialist
- get answers to technical problems

## PROJECTS

- download construction projects (PDF) and associated software
- hundreds of articles available
- search by category, alphabetically and chronologically

## SHOP

- everything you need to build projects, incl. PCB's, books and CD-ROM's. Secure payment system

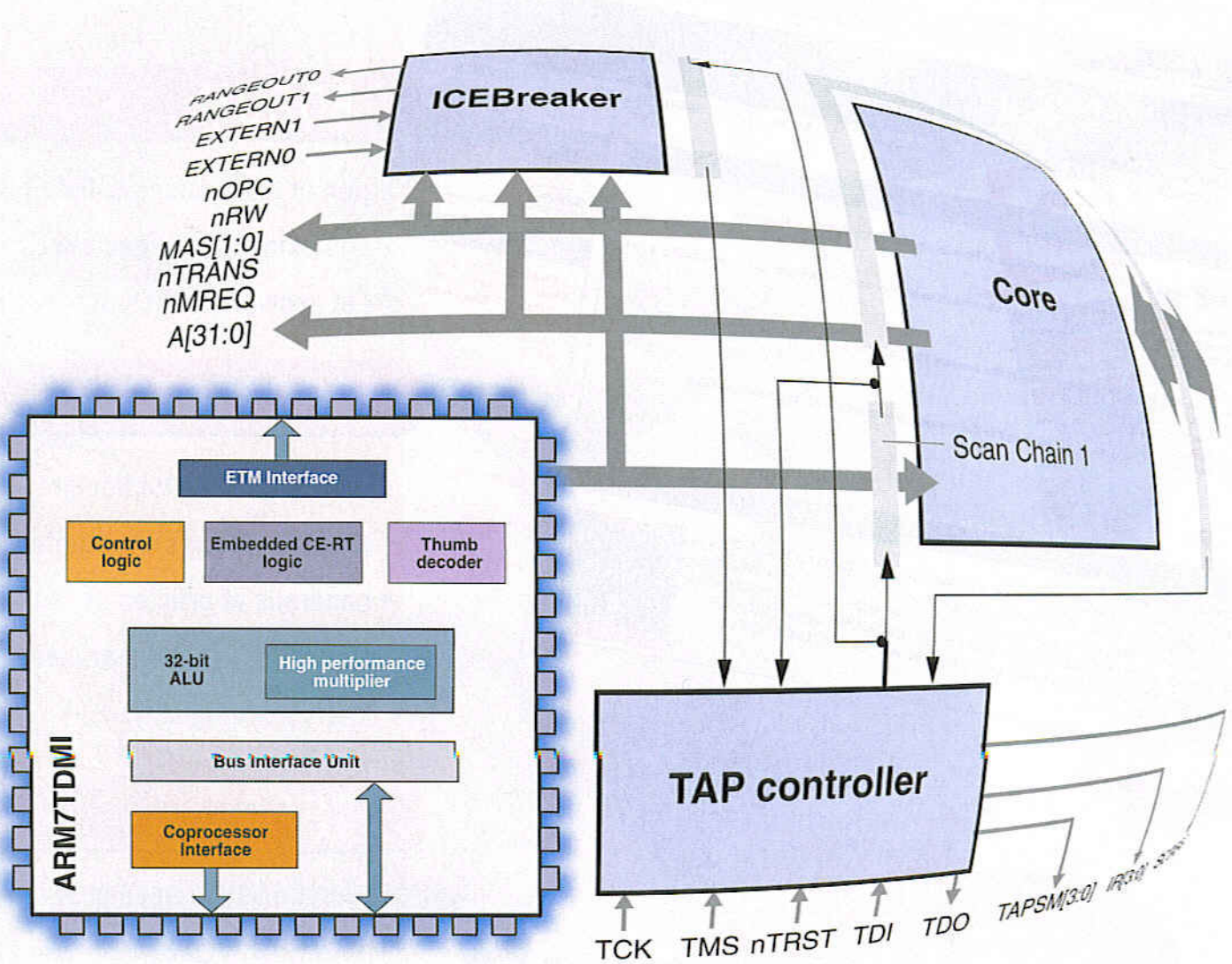
## MARKETPLACE

- the place to visit for components, tools, old volumes, etc.

# LPC210x 'ARMEE'

## Part 1: an ARM processor survey

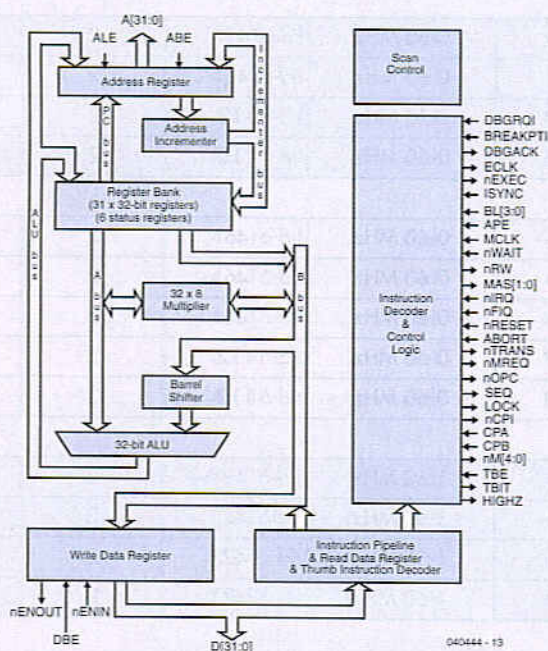
Tony Dixon



In the first instalment of a three-part article we will look at recent developments in 32-bit ARM based microcontrollers, concentrating on those devices that are available, do not cost an arm and a leg or require a major investment in surface mount soldering equipment!

# DEVELOPMENT BOARD (1)

## Overview of the ARM7TDMI core



The ARM7 core is a 32-bit Reduced Instruction Set Computer (RISC). It uses a single 32-bit bus for instruction and data. The length of the data can be 8, 16 or 32 bits and the length of the instruction word is 32 bits.

### What Does TDMI™ mean?

The ARM7TDMI is an ARM7 core with 4 additional features identified with letter codes, as follows

- T: support for the Thumb (16 bit) instruction set.
- D: support for debug
- M: support for long multiplies
- I: include the EmbeddedICE module to support embedded system debugging.

### Thumb mode (T)

An ARM instruction is 32-bits long. The ARM7TDMI processor supports a second instruction set that has been compressed into 16-bits, the Thumb instruction set. Faster execution from 16-bit memory and greater code density can usually be achieved by using the Thumb instruction set instead of the ARM instruction set, which makes the ARM7TDMI core particularly suitable for embedded applications.

However the Thumb mode has two limitations and these are: Thumb code usually uses more instructions for the same job, so ARM code is usually best for maximising the performance of the time-critical code.

The Thumb instruction set does not include some instructions that are needed for exception handling, so the ARM code needs to be used for exception handling. See ARM7TDMI User Guide for details on the core architecture, the programming model and both the ARM and ARM Thumb instruction sets.

### Long multiple (M)

A 32-bit Multiplier function qualifies the core for complex arithmetic tasks usually performed by a DSP. The ARM7TDMI instruction set includes four extra instructions that perform 32-bit by 32-bit multiplication with 64-bit result and 32-bit by 32-bit multiplication-accumulation (MAC) with 64-bit result.

### Debugging (D)

A special hardware extension allows for Debugging within an application. This is made possible by means of a boundary-scan cell array around the core driven by a JTAG port and a TAP controller.

### EmbeddedICE (I)

The EmbeddedICE extends the debugging functions and this module contains the breakpoint and watch point registers that allow the code to be halted for debugging purposes. These registers are controlled through the JTAG test port with the aid of software debugging tools running on a computer. When a breakpoint or watch point is encountered the processor halts and enters debug state. Once in a debug state, the processor registers may be inspected as well as the Flash/EE, SRAM and the Memory Mapped Registers

ARM stands for *Advanced RISC Machine*, where RISC means *Reduced Instruction Set Computer*. The ARM 32-bit architecture has been around for a number of years and has been used in products where low power consumption is essential such as for mobile phones and PDA's.

Its 32-bit core is available in several guises including the ARM7, ARM9, ARM10 and the recently announced ARM11, each of which offers enhanced levels of computing power.

The ARM was usually only available as a microprocessor device, where it required external program and data memory to complete a system. However several companies are now offering a 32-bit ARM based microcontroller with sufficient memory options for them to be considered worthy microcontroller alternatives. **Table 1** shows a selection of ARM based microcontrollers from three companies, Analog Devices, OKI Semiconductors and Philips Semiconductors. Other companies such as Atmel, NetSilicon, Samsung and TI offer similar devices

**Table 1. ARM processor comparison matrix.**

| Device    | Package      | RAM   | Flash  | Clock      | I/Os | UARTs | SPI |
|-----------|--------------|-------|--------|------------|------|-------|-----|
| AduC7020  | 40-pin LFCSP | 8 kB  | 62 kB  | 0.3-45 MHz | 14   | 1     | 1   |
| AduC7021  | 40-pin LFCSP | 8 kB  | 62 kB  | 0.3-45 MHz | 13   | 1     | 1   |
| AduC7022  | 40-pin LFCSP | 8 kB  | 62 kB  | 0.3-45 MHz | 13   | 1     | 1   |
| AduC7024  | 64-pin LQFP  | 8 kB  | 62 kB  | 0.3-45 MHz | 30   | 1     | 1   |
| AduC7025  | 64-pin LQFP  | 8 kB  | 62 kB  | 0.3-45 MHz | 30   | 1     | 1   |
| AduC7026  | 80-pin LQFP  | 8 kB  | 62 kB  | 0.3-45 MHz | 40   | 1     | 1   |
| AduC7027  | 80-pin LQFP  | 8 kB  | 62 kB  | 0.3-45 MHz | 40   | 1     | 1   |
|           |              |       |        |            |      |       |     |
| LPC2104   | 48-pin TQFP  | 16 kB | 128 kB | 0-60 MHz   | 32   | 2     | 1   |
| LPC2105   | 48-pin TQFP  | 32 kB | 128 kB | 0-60 MHz   | 32   | 2     | 1   |
| LPC2106   | 48-pin TQFP  | 64 kB | 128 kB | 0-60 MHz   | 32   | 2     | 1   |
|           |              |       |        |            |      |       |     |
| LPC2114   | 64-pin LQFP  | 16 kB | 128 kB | 0-60 MHz   | 46   | 2     | 2   |
| LPC2124   | 64-pin LQFP  | 16 kB | 256 kB | 0-60 MHz   | 46   | 2     | 2   |
| LPC2212   | 144-pin LQFP | 16 kB | 256 kB | 0-60 MHz   | 112  | 2     | 2   |
| LPC2214   | 144-pin LQFP | 16 kB | 256 kB | 0-60 MHz   | 112  | 2     | 2   |
|           |              |       |        |            |      |       |     |
| LPC2119   | 64-pin LQFP  | 16 kB | 128 kB | 0-60 MHz   | 46   | 2     | 2   |
| LPC2129   | 64-pin LQFP  | 16 kB | 256 kB | 0-60 MHz   | 46   | 2     | 2   |
| LPC2194   | 64-pin LQFP  | 16 kB | 256 kB | 0-60 MHz   | 46   | 2     | 2   |
| LPC2292   | 144-pin LQFP | 16 kB | 256 kB | 0-60 MHz   | 112  | 2     | 2   |
| LPC2294   | 144-pin LQFP | 16 kB | 256 kB | 0-60 MHz   | 112  | 2     | 2   |
|           |              |       |        |            |      |       |     |
| ML674001  | 144-pin LQFP | 32 kB | 256 kB | 1-60 MHz   | 42   | 2     | 1   |
| ML674001  | 144-pin LQFP | 32 kB | 512 kB | 1-60 MHz   | 42   | 2     | 1   |
| ML675001A | 144-pin LQFP | 32 kB | 256 kB | 1-60 MHz   | 42   | 2     | 1   |
| ML675001A | 144-pin LQFP | 32 kB | 512 kB | 1-60 MHz   | 42   | 2     | 1   |

but these are usually available in larger BGA (ball grid array) packaging only, making them less suitable for hand prototyping. So what's available on the ARM market we can actually obtain and handle? Let's have a look what a number of major manufacturers in the ARM arena have on offer.

## Analog Devices

Analog Devices ([www.analog.com](http://www.analog.com)) is not a name normally associated with microcontrollers, however they are about to change this view by creating a microcontroller product with a range of precision analogue interfaces. *Elektor Electronics* (leading the way!) have already published a series of articles on Analog Devices AduC812 8052 based controllers (Ref. 1). Analog Devices have released an updated range using an ARM7TDMI as the computing engine.

The ADuC702x family of devices from Analog Devices integrates a 32-bit ARM7TDMI core with a 12-bit data converter that can have up to 16 channels supporting one million samples/sec. The ADuC702X devices also feature up to four 12-bit DACs with a precision bandgap reference sensitive to 10 ppm/°C. Other peripherals include a comparator, a small programmable-logic array

(PLA) for glue logic, an on-chip temperature sensor ( $\pm 3^\circ\text{C}$ ) and a three-phase 16-bit PWM generator. Of these peripherals the programmable-logic array is the most interesting to find on a microcontroller.

A JTAG interface is provided for debugging the chip, while the UART can be used to program the Flash memory *in-situ*.

An on-chip oscillator will drive the ADuC702x at speeds of up to 35 MHz and is 2% accurate. An external clock is required to run at speeds up to the 45-MHz limit. Memory options include both a 32-kByte Flash memory for the ADuC7024 and a 62-kByte Flash memory for the ADuC7026 and all include 8 kBytes of RAM. Packaging options range from a 6x6-mm, 40-lead CSP, a 64-pin LQFP and an 80-pin LQFP. These 3-V devices can operate within a temperature range of  $-40$  to  $+85$ , or at extended temperatures up to  $+105$ , or  $+125^\circ\text{C}$ .

Analog Devices offer a low-cost quick start development system called QuickStart, which includes a power supply, cables, evaluation board, JTAG emulator and software-development tools from Keil Software and IAR Systems.

The QuickStart Development System sells for \$249 and is available directly from Analog Devices.

Of the devices offered, the 64-pin and 80-pin devices

| I2C | CAN | Timers     | PWM  | ADC         | DAC        | Notes                          |
|-----|-----|------------|------|-------------|------------|--------------------------------|
| 2   | -   | 2          | -    | 5 x 12-bit  | 4 x 12-bit | PLA, Temp Sensor               |
| 2   | -   | 2          | -    | 8 x 12-bit  | 2 x 12-bit | PLA, Temp Sensor               |
| 2   | -   | 2          | -    | 10 x 12-bit | -          | PLA, Temp Sensor               |
| 2   | -   | 2          | 3    | 10 x 12-bit | 2 x 12-bit | PLA, Temp Sensor, 3-Phase      |
| 1   | -   | 2          | 3    | 12 x 12-bit | -          | PLA, Temp Sensor, 3-Phase      |
| 1   | -   | 2          | 3    | 12 x 12-bit | 4 x 12-bit | PLA, Temp Sensor, 3-Phase      |
| 1   | -   | 2          | 3    | 16 x 12-bit | -          | PLA, Temp Sensor, 3-Phase      |
| 1   | -   | 4 x 16-bit | 6-ch | -           | -          |                                |
| 1   | -   | 4 x 16-bit | 6-ch | -           | -          |                                |
| 1   | -   | 4 x 16-bit | 6-ch | -           | -          |                                |
| 1   | -   | 4 x 16-bit | 6-ch | 4 x 10-bit  | -          |                                |
| 1   | -   | 4 x 16-bit | 6-ch | 4 x 10-bit  | -          |                                |
| 1   | -   | 4 x 16-bit | 6-ch | 8 x 10-bit  | -          | with external memory interface |
| 1   | -   | 4 x 16-bit | 6-ch | 8 x 10-bit  | -          | with external memory interface |
| 1   | 2   | 4 x 16-bit | 6-ch | 4 x 10-bit  | -          |                                |
| 1   | 2   | 4 x 16-bit | 6-ch | 4 x 10-bit  | -          |                                |
| 1   | 4   | 4 x 16-bit | 6-ch | 4 x 10-bit  | -          |                                |
| 1   | 2   | 4 x 16-bit | 6-ch | 8 x 10-bit  | -          | with external memory interface |
| 1   | 4   | 4 x 16-bit | 6-ch | 8 x 10-bit  | -          | with external memory interface |
| 1   | -   | 7 x 16-bit | 2-ch | 4 x 10-bit  | -          | with external memory interface |
| 1   | -   | 7 x 16-bit | 2-ch | 4 x 10-bit  | -          | with external memory interface |
| 1   | -   | 7 x 16-bit | 2-ch | 4 x 10-bit  | -          | external memory i/f, 8K cache  |
| 1   | -   | 7 x 16-bit | 2-ch | 4 x 10-bit  | -          | external memory i/f, 8K cache  |

are probably the most usable by our readership for their prototyping ease.

## Philips

Of all the companies offering ARM microcontrollers Philips ([www.semiconductors.philips.com](http://www.semiconductors.philips.com)) seem to be the company pushing the ARM microcontroller the most and have already released an extensive range of microcontrollers based on a 32-bit ARM7TDMI-S core (see **inset**). Philips initially offered the LPC210x which featured 16 to 64 kB of RAM dependant on the device, together with 128 kB of Flash memory and all operating at 60 MHz. Other peripherals include two UARTs, SPI and I<sup>2</sup>C interfaces, 6-channel PWM and 32-bit digital I/O port. All of which are fitted in a small 48-pin LQFP package!

All three controller chips are based on a common system architecture approach which offers the same memory map, vectored interrupt controller and similar peripheral complements. Also common to them are the same Flash programming and updating mechanism, JTAG debugging and emulation facilities.

These devices operate from 1.8 V for the core CPU functions and 3.3 V for the I/O and peripherals, with the general I/O being 5 V tolerant.

Philips has extended the LPC21xx family to include new devices packaged either in a 64-pin or a 144-pin LQFP. These new family members offer larger Flash memory options, an additional SPI interface and additional digital I/O lines. They also included either a 4 or 8 channel ADC with 10-bit resolution, 2- or 4-channel CAN bus interface and the option of an external memory interface on the larger 144-pin devices.

The LPC210x devices have a number of development and evaluation boards from companies such as Hitek, Keil, IAR and Nohau.

According to press releases from Philips we can expect future members of the LPC21xx and LPC22xx family to include Ethernet, USB, and 802.11 capabilities. Something to look forward to!

## OKI Semiconductors

OKI Semiconductors ([www.oki.com](http://www.oki.com)) are a Japanese company who offer a broad range of ICs and have been providing 32-bit ARM-based solutions for a number of years. Oki have extended its microcontroller portfolio by introducing a new series of general-purpose 32-bit microcontrollers based on an ARM7TDMI core.

These new two lines consist of the ML674001 and the

ML675001 series. The ML674001 series comprises of three products: the ML674001, the ML67Q4002 and the ML67Q4003. While the ML675001 series consisting of the ML675001, the ML67Q5002 and the ML67Q5003. The ML674001 and ML675001 are ROMless parts.

The ML67Q4002/3 and ML67Q5002/3 microcontrollers offer large Flash memory options up to 512 kB and 32 kB of RAM. Other peripherals include 1 × system timer, 6 × general purpose timers, 2 × PWM, watch dog timer, general purpose I/O ports, ADC converters and 2 × DMA channels. Communications are provided 2 × UARTs; one UART is an industry standard 16550A and has 16 bytes FIFO for both send and receive, with the other having no FIFO; an I<sup>2</sup>C and SPI interface. The chips also include an external memory interface that features a SDRAM controller allowing for ROMs (including Flash memories), SRAMs, DRAMs, or I/O devices can be directly connected to the on-board SDRAM controller. A standard JTAG interface is provided for debugging and device programming. These chips can also be programmed by using a special Boot mode program built into the device. In boot mode, the on-chip boot ROM downloads a Flash writing application into the internal RAM area of the MCU. This application then handles the serial transfer and writing of internal Flash through the UART interface of the MCU.

The chips require 2.5 V for the core CPU functions and 3.3 V for the I/O and peripherals. The series operate in

a wide temperature range of -40°C to +85°C. The ML674001 series can operate at a maximum frequency of 33 MHz, while the ML675001 series operates at a maximum frequency of 60 MHz. The ML675001 series has an 8-kB unified cache memory allowing the chip to operate at the higher clock speed.

The ML67Q4002/3 and ML67Q5002/3 are packaged in a 144-pin LQFP and all the microcontrollers are of a pin-compatible design, allowing for easier upgrade from the ML674001 series to the ML675001 series with a minimum of program and board layout change.

## Next month's issue

has a heavy focus on microcontrollers and it is no coincidence that you will be able to read about an extremely powerful ARM microcontroller development system you can build at home, in class or in the lab. As far as we know, this is a first in electronics magazine publishing but then again who else but Elektor?

(040444-1)

### Reference:

1. Intelligent Sensor/Actuator Controller (ISAC), parts 1-4, Elektor Electronics October - December 2001 and January 2002.

Advertisement



£ 69.00 / US\$ 112.50  
(plus postage)

## Flash Microcontroller Starter Kit

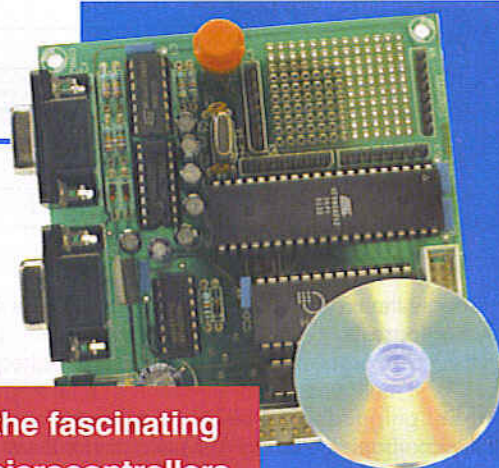
*Elektor Hardware & Software*

Contents of Starter Kit:

89S8252 Flash Microcontroller board (ready-assembled and tested PCB), 300-mA mains adapter, serial cable for COM port and a software bundle on CD-ROM. Article compilation on CD-ROM:

- 89S8252 Flash Microcontroller Board (December 2001)
- Microcontroller Basics Course parts 1-6 (January through June 2002)
- Microcontroller Basics FAQ (September 2002)
- Port Line and ADC Extension for 89S8252 Flash Micro Board (December 2002)
- Chess Computer using the Flash Micro Board.

**Step into the fascinating world of microcontrollers**



Order now using the Order Form in the Readers Services section in this issue.

Elektor Electronics (Publishing)

P.O. Box 190

Tunbridge Wells TN5 7WY England

Telephone +44 (0) 1580 200 657

Fax +44 (0) 1580 200 616

See also

[www.elektor-electronics.co.uk](http://www.elektor-electronics.co.uk)

# Affordable, Professional ARM7 C/C++ Development!

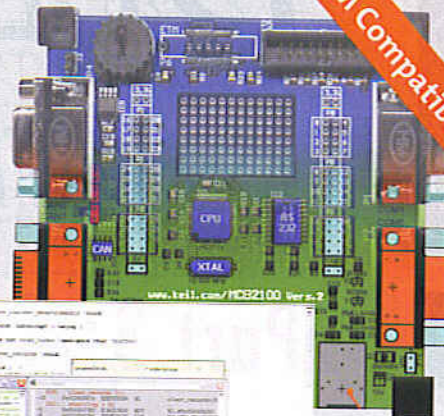
Everything required for LPC2000 Philips ARM7 development  
in a single, upgradeable kit.

- ✓ Industry standard Keil uVISION3 IDE, C/C++ compiler and simulator
- ✓ Full Simulation of LPC2000 with peripheral & interrupt support
- ✓ Fully assembled LPC2129 board
- ✓ 16k RAM, 256k FLASH on board
- ✓ Dual CAN and RS232 interfaces
- ✓ JTAG and ETM trace debug interfaces
- ✓ Example program library
- ✓ uLINK USB-JTAG interface (optional)

Basic 16k code development kits from £75 +VAT

Full 16k development kit with JTAG-USB debugger £249+VAT

(Academic price just £149+VAT!)



TantoARM Compatible

For full details see [www.hitex.co.uk/arm](http://www.hitex.co.uk/arm)



£ 16.25 / US\$ 28.75  
ISBN 90-5381-184-2

## New CD-ROM Elektor 2004

All articles in *Elektor Electronics* Volume 2004 on CD-ROM

This CD-ROM contains all editorial articles, with the exception of New Products items, published in *Elektor Electronics* magazine Volume 2004. Using the supplied Acrobat Reader program, articles are presented in the same layout as originally found in the magazine. The DiskMirror utility on this CD-ROM allows your earlier Elektor year volume CD-ROMs (1997-2003) to be added to a large archive on hard disk for fast access and easy reference. A built-in search function allows you to find references in any article from the archive on hard disk, or from individual year volume CD-ROMs you have available.



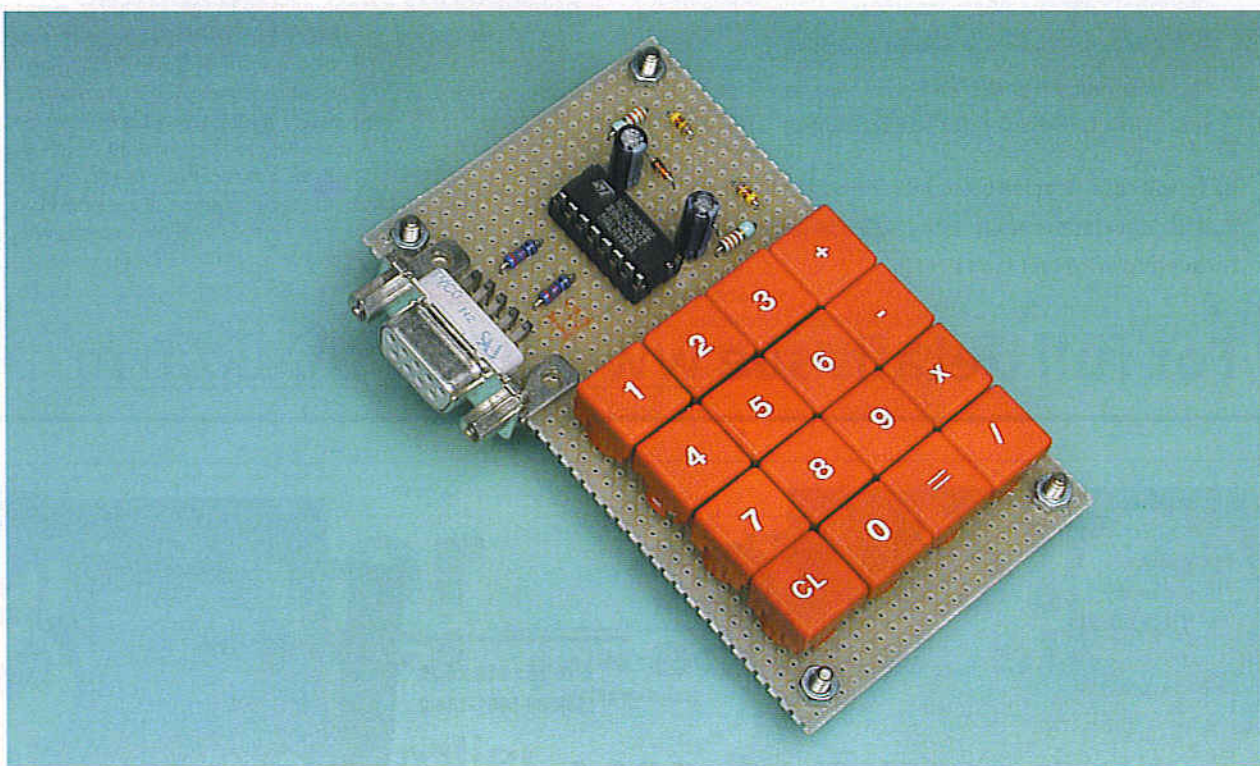
Order now using the Order Form in the Readers Services section in this issue.

Elektor Electronics (Publishing)  
P.O. Box 190  
Tunbridge Wells TN5 7WY England  
Telephone +44 (0) 1580 200 657  
Fax +44 (0) 1580 200 616

See also  
[www.elektor-electronics.co.uk](http://www.elektor-electronics.co.uk)

# DELPHI FOR ELECTRONIC ENGINEERS

## Part 3 – An external calculator



**Herman Bulle** with thanks to Anton Vogelaar

In the previous article we saw how we could implement a simple calculator using Delphi. This time we connect an external keypad to the serial port, to allow the calculator to be controlled externally. We'll use the program from the last article (slightly modified) to put the numbers onto the display and to perform the calculations.

The external keypad, which we'll build ourselves, consists of 16 keys in a configuration of 4 rows by 4 columns. When a key is pressed, a single row is connected to a single column. The combination of the exact row and column is unique for each key.

By activating each column in turn and then checking which row has a signal, we can determine which key has been pressed. Before we continue with the practical side we would like to point out that the complete listing for this project would

take up too much space in this magazine. The listing (project files) can be downloaded from the Elektor web-site from the Delphi course for March. We recommend that you download this first and load it into Delphi; this makes it easier to follow the next description.

## Connecting the hardware

A CMOS type 4555 data selector is used to activate the columns (see **Figure 1**). This is a dual 1-to-4 decoder/multiplexer. Each decoder in the IC has a 2-bit digital input and 4 outputs. Depending on the binary value of the input (00, 01, 10, 11), one of the outputs of the IC will be driven high.

The RS232 port of the computer has two output signals: **DTR** (Data Terminal Ready, pin 4) and **RTS** (Request To Send, pin 7). As a reminder we have shown the full connection details of a 9-way RS232 connector in *Figure 1*. These two signals are used to drive the line-selector inputs of the 4555. Before we can do this we should provide a supply voltage to the IC. Since a CMOS IC consumes very little power it is quite easy to derive the supply from these two signals. When we're not looking for a key-press there is no need to drive the data selector inputs. We can then keep DTR at '1' and RTS at '0'. It is very easy to derive a symmetrical supply of  $\pm 7.5$  V ( $V_{DD} = 15$  V), using a handful of resistors, zeners and electrolytic capacitors (R1, R2, D1-D4, C1, C2 in *Figure 1*). The capacitors are sufficiently large to supply a stable voltage to the IC during a complete scan period. All that's left is to add a little protection to the inputs since the input voltage could be larger than the supply voltage. By adding a 10 k $\Omega$  to the signal path the input current is kept to a safe level.

If you're using a laptop you should first measure the RS232 output voltages, as these occasionally deviate from the official RS232 specification (some Dell laptops had outputs of only  $\pm 5$  V). In this instance the zeners are no longer needed. We have also seen asymmetric outputs (+5 V/0 V), so it is worth checking this out.

Building the circuit of *Figure 1* is fairly straightforward. The IC, passive components and 16 keys are easily mounted onto an experimenter's board, and it doesn't take long to do the wiring either. You could use an old RS232 cable for the connection to the PC, with a plug cut off from one end (Make sure that you keep the female connector on the cable, since that is required to plug into the PC). The wires can then be soldered directly to the board. As an alternative to individual keys you could also use a matrix keypad (obtainable from Conrad and many other suppliers). Often these come in sizes of 4x3, in which case two keypads can be 'connected in parallel', using just a single column from the second one.

## Software switching

To drive the DTR and RTS lines we'll have to write a bit of Delphi code.

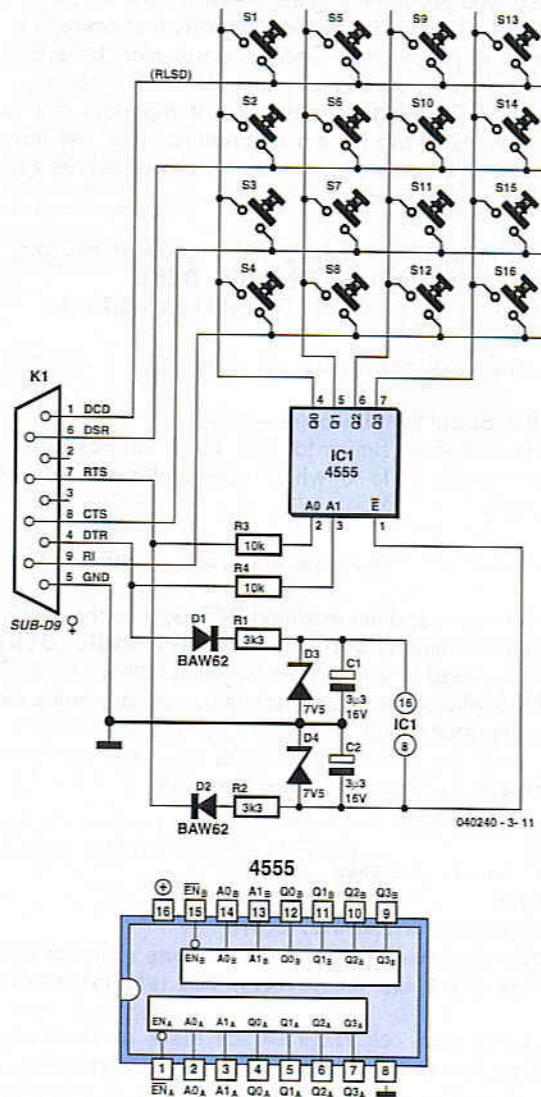
To start with, we have to open the serial port. We have already covered this in Part 1 for the burglar alarm:

```

FHandle:=CreateFile(PChar(Port),Generic_Read+
Generic_Write,0,Nil,Open_Existing,0,0);
If FHandle = Invalid_Handle_Value Then
Begin
  ShowMessage('Unable to open communication port.');
```

```

  Exit
End;
```



*Figure 1.* The circuit for the external keypad, which connects to the PC's serial port.

*(As a reminder: Delphi programs are not 'case sensitive', unlike C and several other programming languages. Because of this, it may happen that we don't always use capitals and small letters the same way in different parts of the program.)*

In the program mentioned above this line had an error-check added: if the port was already open it wouldn't be opened again.

Windows keeps a list of various objects such as programs, ports, drivers etc. These objects are given a unique code (or handle). The function **CreateFile**, called above, returns the value of this code. If this value is equal to **Invalid\_Handle\_Value**, which is defined in Delphi, something went wrong during the initialisation of the port and the program is halted with a message and the **exit** command.

On successful completion of this phase we have to activate a few outputs. DTR has to be set to +12 V and RTS to -12 V.

To help with programming the UART, a data structure (**DCB**, see inset) is defined in Windows that contains a large set of parameters. Once all parameters have been set, this data structure is sent to the UART. For our program the **DCB.Flags** field is the most important. In this field virtually all bits have a separate function. We have defined two constants in `uDriver`, which are required to turn DTR and RTS 'on' and 'off'.

First the current state of the UART is read with the command **GetCommState(FHandle, DCB)**. Next we set a bit in the **FLAGS** field to turn RTS on:

```
DCB.Flags := DCB.Flags OR RtsEnable
```

The RTS output then becomes -12 V. We do something similar for DTR, but in this case we have to set the bit to '0' while keeping all the other bits the same:

```
DCB.Flags := DCB.Flags AND (NOT DtrEnable)
```

We can now send the modified DCB back to the UART using the command **SetCommState(FHandle, DCB)**. Since we need to use all possible combinations of DCD and RTS when selecting the columns, we have written the following procedure:

```
Procedure Key_Out(RTS, DTR: Boolean);
Var DCB: TDCB;
Begin
  IF FHandle > 0 Then
  Begin
    GetCommState(FHandle, DCB);
    If DTR Then DCB.Flags := DCB.Flags Or DtrEnable
    Else DCB.Flags := DCB.Flags And (NOT DtrEnable);

    If RTS Then DCB.Flags := DCB.Flags Or RtsEnable
    Else DCB.Flags := DCB.Flags And (NOT RtsEnable);

    SetCommState(FHandle, DCB)
  End
End;
```

To turn on the supply voltage to the IC we call this function with the following parameters: **Key\_Out(False, True)**. This is done every time after scanning the keys, thereby keeping the capacitors fully charged.

## Scanning the matrix

The next building block required for this project has to take care of the reading of the status of the four input lines. With the help of the procedure **GetComm-ModemStatus(FHandle, MdmSts)** these details are stored in the variable `MdmSts`. By applying a mask we can determine which bit, if any, is set to '1'. A mask is a number which has just a single bit set to '1', for example binary 1000 (= hex 10), binary 10000 (= hex 0020) etc. Delphi has already defined some important values for us:

```
MS_CTS_ON = hex 0010
MS_DSR_ON = hex 0020
MS_RING_ON = hex 0040
MS_RLSD_ON = hex 0080;
```

If we now apply the mask using the Boolean AND function we can determine if this bit is set. This therefore tells us if a key in this row is pressed:

```
If MdmSts And MS_RLSD_ON = MS_RLSD_ON Then
  Result := 1
```

The same method is used to check if a key is pressed in the other rows. The result will be 1,2,3 or 4, depending on the selected row.

These lines of code have been combined in the function **Key\_Inp**, which returns the value of the selected row.

## Combining the routines

In principle that is all there is to do: we know how to select a column and how to read on which row a key is pressed. However, these functions still have to be 'glued together' and the result has to be shown on the display. This takes place as follows: a timer is used to call the function **GetKey** at regular intervals. This calls the procedure **Key\_Out** to select a column, for example `Key_out(False, False)`. Next we use **Key\_Inp** to check if a key in that column has been pressed. A small section of this procedure is shown below: if no key is pressed in the first column, the variable `Row` becomes 0. If a key is pressed, `Key_inp` returns the row number.

```
If row=0 then
  Begin
    col:=2;
    Key_Out(False, True);
    row:=Key_Inp;
  End;
If row=0 then
  col:=3
```

In this way the entire keypad matrix is scanned. Once the row and column are known, the correct key number is looked up using the conversion matrix **Map [row,col]**, as follows. We do have to make sure that we don't read 2 key presses if a key is held down a bit longer. This is where the variable **KeyLast** comes to the rescue. If we insist on at least one scan without a key press between two successive key presses, we can use that to distinguish two real key presses from a single one, which is held down too long.

The previous key press should therefore always be an empty scan (with key number 0) for the current scan to be valid.

Every old key press is stored in the variable **KeyLast**. When we're scanning for a new key press the result will only be valid if the old scan (stored in **KeyLast**) was 0. Adding the following line to the end of the **GetKey** procedure stops the generation of false key presses:

```
If (KeyLast = 0) Then Result := Key
else result:=0;
KeyLast := Key;
```

We then store the value of the scanned key in **KeyLast**. This nearly completes this section. We just have to make sure that the supply voltages are restored at the end of a scan. This is done by calling `Key_Out(False, True)` once more, which sets DTR to +12 V and RTS to -12 V. Apart from the procedures mentioned above for driving and reading the RS232 port, there is another procedure (`KeyGet`), which is used during the simulation of the program. The intention is that only one of the two functions is active. The other is removed using curly brackets (in Delphi any text between curly brackets is interpreted as a comment). In the simulation the tag of the key is read, which we

# Device Control Block

The Device Control Block contains a list of parameters that are required to configure a serial port. The elements BaudRate, StopBits etc. are easily recognised. It is defined as a record of type TDCB and has the following structure:

|             | Type    | Size |
|-------------|---------|------|
| dcblength   | dword   | 4    |
| baudrate    | dword   | 4    |
| flags       | longint | 4    |
| wreserved   | word    | 2    |
| xonlim      | word    | 2    |
| xofflim     | word    | 2    |
| bytesize    | byte    | 1    |
| parity      | byte    | 1    |
| stopbits    | byte    | 1    |
| xpmcjar     | char    | 1    |
| xoffchar    | char    | 1    |
| errorchar   | char    | 1    |
| eofchar     | char    | 1    |
| evtchar     | char    | 1    |
| wreserved11 | word    | 2    |

The flags are of particular interest here. Each bit in the 16-bit word has a unique function, which is shown in the table below:

|                     |            |
|---------------------|------------|
| Binary              | \$00000001 |
| ParityCheck         | \$00000002 |
| OutxCtsFlow         | \$00000004 |
| OutxDsrFlow         | \$00000008 |
| DtrControlMask      | \$00000030 |
| DtrControlDisable   | \$00000000 |
| DtrControlEnable    | \$00000010 |
| DtrControlHandshake | \$00000020 |
| DsrSensitivity      | \$00000040 |
| TXContinueOnXoff    | \$00000080 |
| OutX                | \$00000100 |
| InX                 | \$00000200 |
| ErrorChar           | \$00000400 |
| NullStrip           | \$00000800 |
| RtsControlMask      | \$00003000 |
| RtsControlDisable   | \$00000000 |
| RtsControlEnable    | \$00001000 |
| RtsControlHandshake | \$00002000 |
| RtsControlToggle    | \$00003000 |
| AbortOnError        | \$00004000 |
| Reserveds           | \$FFFF8000 |

When the symbol '\$' is in front of a number it means it is a hexadecimal number.

In this case we only make use of the numbers \$00000010 (DtrControlEnable) and \$00001000 (RtsControlEnable). The others don't really concern us here.

More information can be found in the Windows SDK section accessed from the Delphi Help menu.

described in the previous article. This value is put into the variable KeyPressed. In the simulation mode this value is passed as the result of the function GetKey and subsequently processed. From this point onwards the program is the same whether in simulation mode or when using an external keypad.

We now know how to read the keys. From the main program (in the unit uConsole) we start a timer that calls a procedure every 50 ms to read the key matrix. The procedure ControlExe (in uControl) separates the received IDs (1 to 16) into two groups. When ID ≤ 10 a digit was pressed and a number is being entered. When ID > 10 an action is requested. In that case we subtract 10 from the ID and execute the appropriate action from the list defined in Tmath. As an example: 'subtraction' has an ID or tag of 12. Process 2 is mtSub (counting from 0) and this generates a subtraction. When the process has finished, a Screenrefresh is executed, which shows the result in the display of the calculator.

## Functional design

Observant readers will have noticed that this program consists of three functional blocks, which are the three units. The basis for this division is that complicated problems are best described as a block diagram, which is also common practice in electronics. If you have a clear division between these blocks you can describe and test the working of the individual blocks better, and the chance of introducing design faults becomes smaller. In this project we have split the software into three layers (in the software world we talk about layers in this context).

We have a presentation layer (uConsole), which receives the results from the simulated keys, a control layer (uControl), which runs the processes in the proce-

dures ControlExe and a driver layer (uDriver), which takes care of the communications with the outside world via the RS232 port.

In this instalment we have shown you how to implement 4 command lines and 4 status lines under Windows for use external to the computer, with only minimal hardware and a serial port. Since most desktops have two serial ports as standard, a total of 8 command lines and 8 status lines are available for external use.

(040249-3)

## Ordering Delphi 7

Borland has made the Personal version of Delphi 7 available cheaply especially for this course. The CD costs € 10.00 (ten euros) and contains Delphi 7 as well as several extra files for this course. It can be paid for by credit card (see website below) or bank transfer (in the EC) by transferring to (please copy exactly):

Bank: ABNAMRO  
 IBAN: NL31 ABNA 0577002562  
 BIC: ABNANL2A  
 Name: DETLEF D. OVERBEEK  
 Address: EDELSTENENBAAN 21 IJSSELSTEIN  
 Post code: 3402 XA  
 Country: THE NETHERLANDS  
 Reference: DELPHI ELEKTOR

IBAN/BIC payments should not incur bank costs when processed correctly — ask your bank for details. Cheques are not acceptable. The HCC PGG has set up a special website in support of this course: [www.learningdelphi.info/](http://www.learningdelphi.info/)

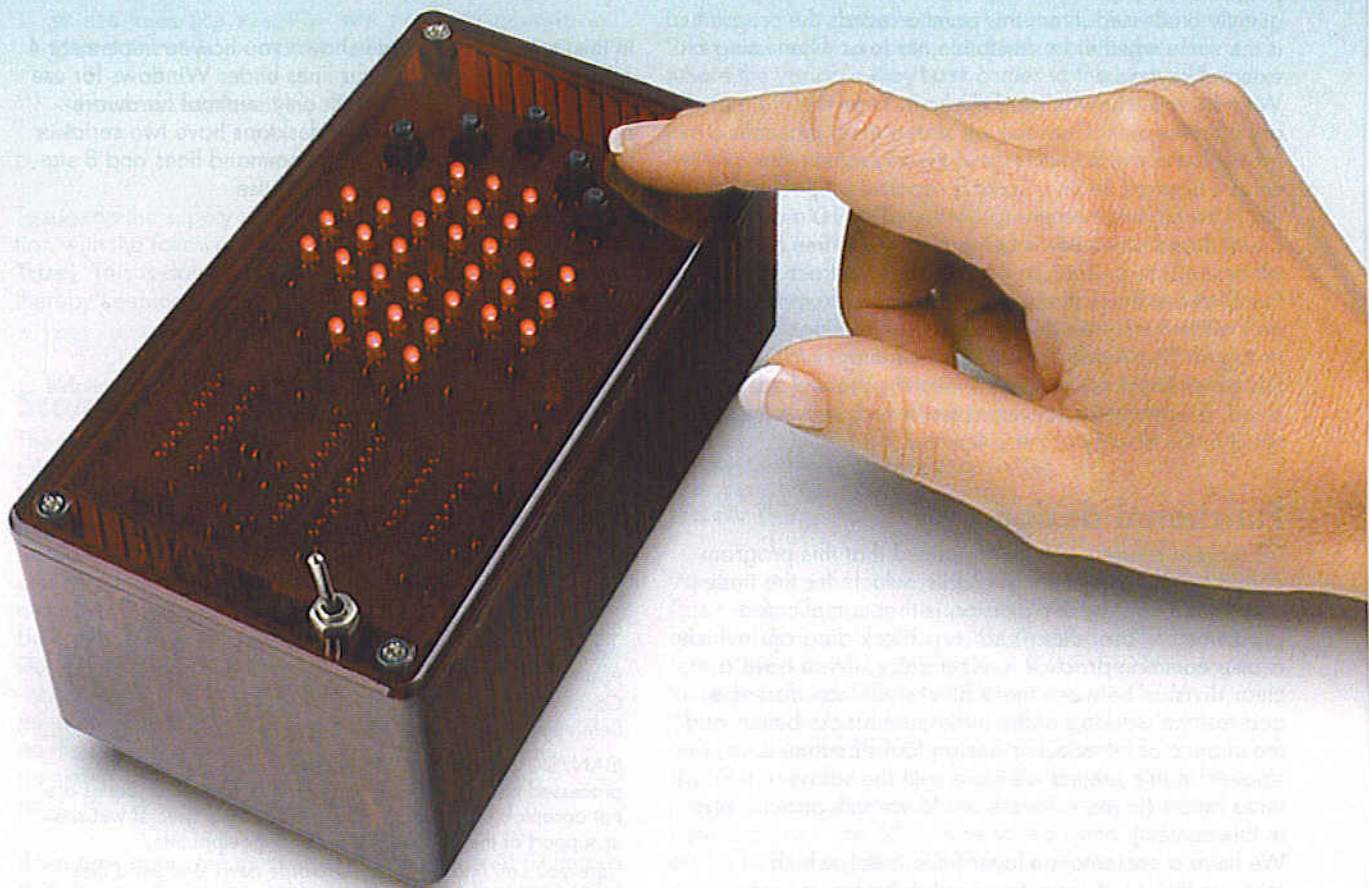
Here you can find the most up-to-date news and extra files for the course, as well as credit card payment options.

# PLAY SOLITAIRE

...packed in an AT90S micro

Andy & Rose Morrell

This version of Solitaire is played with an array of LEDs instead of pegs, with a microcontroller behind the scenes to check if you're any good at playing. As you'll soon find, the game is challenging and addictive!



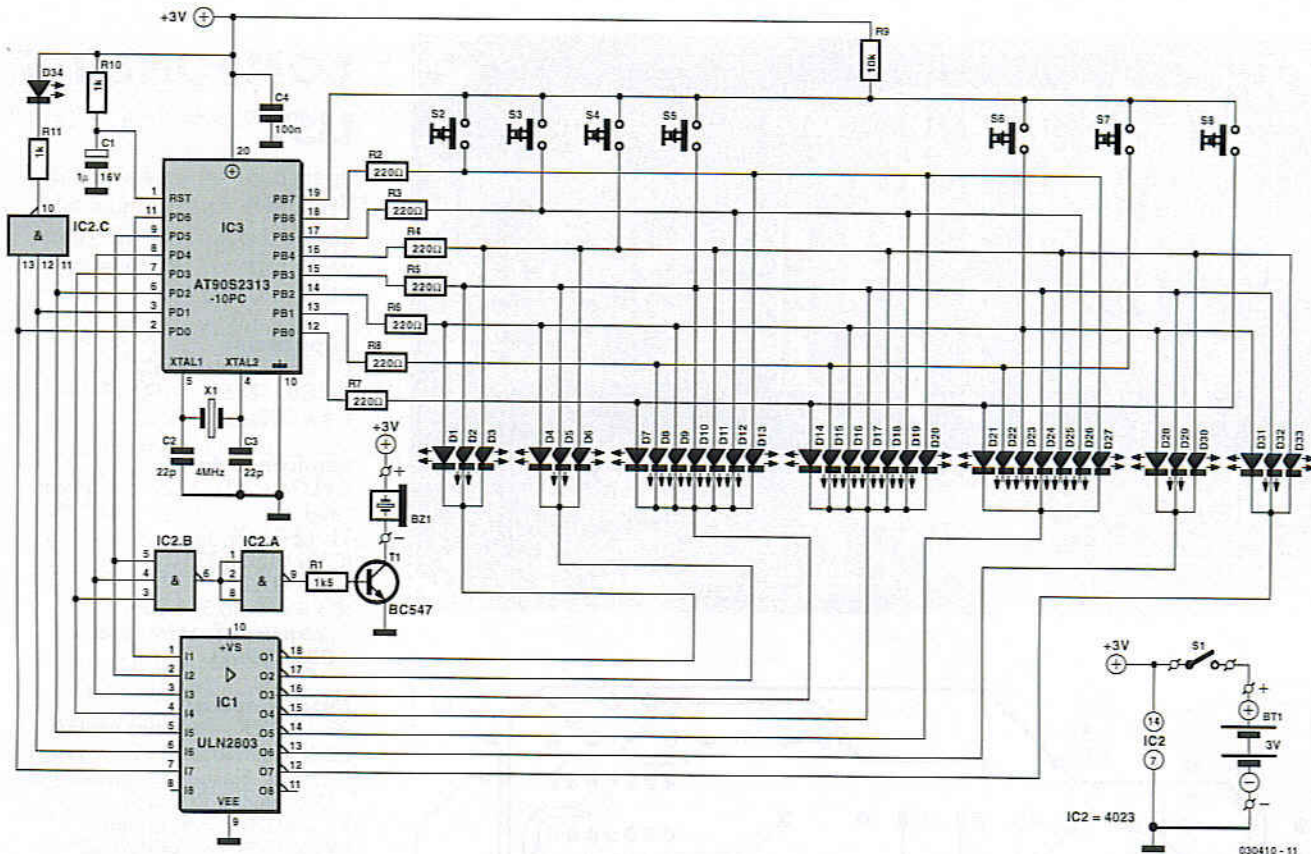


Figure 1. At the heart of the Solitaire game you'll find an AT90S2313 microcontroller running some really clever software.

This project is a fine instance of a microcontroller and its resident software slashing component count when implementing a logic circuit, as well as providing yet another answer to the perennial "great-but-what-do-you-do-with-it?" question from outsiders and newbies when discussing those multi-legged beasts commonly known as microcontrollers.

The design is based on the Atmel AT90S2313 microcontroller which was selected for its low cost, speed, number of I/O lines and ease of programming in assembly code using free tools.

### The hardware

If you think of a microcontroller acting like a black box and sitting between input and output devices like switches and LEDs, then the circuit diagram in Figure 1 is nothing special. It does, however, contain a few ingenious solutions when it comes to marrying software to hardware that's to remain as simple and reproducible as possible. The AT90S2313 micro, IC1, runs at a clock frequency of 4 MHz obtained with the aid of quartz crystal X1. The

two 22-pF capacitors serve as parallel load devices for the oscillator/crystal configuration (note that the oscillator is on board the AT micro).

Output devices controlled by the AT90 micro comprise active buzzer Bz1, LEDs D1-D33 mimicking the playing field and LED D34 to confirm that the move has been performed. The buzzer sounds in response to the microcontroller software activating the PD3, PD4 and PD5 lines at the same time. This condition is signalled by NAND gate IC2.B, with IC2.A acting as an inverter only. A similar arrangement but without logic inversion is used for LED D34, which lights when PD0, PD1 and PD2 are logic High at the same time. Here, IC2.C is the responsible NAND gate.

All Port lines PD0 through PD6 are applied to the inputs of an ULN2803 driver IC. Note the inverting action of this IC — it will pull the commoned cathodes of the LED sets low in response to a high level on the port lines. The anodes of the LEDs are connected to port lines PB0 through PB7 via 220-ohm current limiting resistors. In this way, each individual LED in the playing area can be turned on an off

using just 15 control lines instead of... right, 33! The process is called multiplexing. Here, it relies on software.

As to input devices, a number of PB on IC1 lines are also connected to switches, requiring them to act as inputs as well as outputs — in a controlled manner, of course! Pushbutton activity is detected on port line PB7 which is exclusively an input.

Switches S1-S4 are the cursor (direction) controls, while S6, S7 and S8 act as the SELECT, CANCEL and STALEMATE controls.

The microcontroller is reset at power-on by a brief logic Low level obtained from network R10-C3.

The circuit does not have a voltage regulator and is powered directly from a 3-volts supply made from two series connected 1.5-V dry batteries.

### Rules for playing Solitaire

As the name suggests, Solitaire is a game to be played on your own. The board is made up of 33 LEDs laid out in a cross shape, where a piece on the board (or 'peg') is indicated by an active LED.

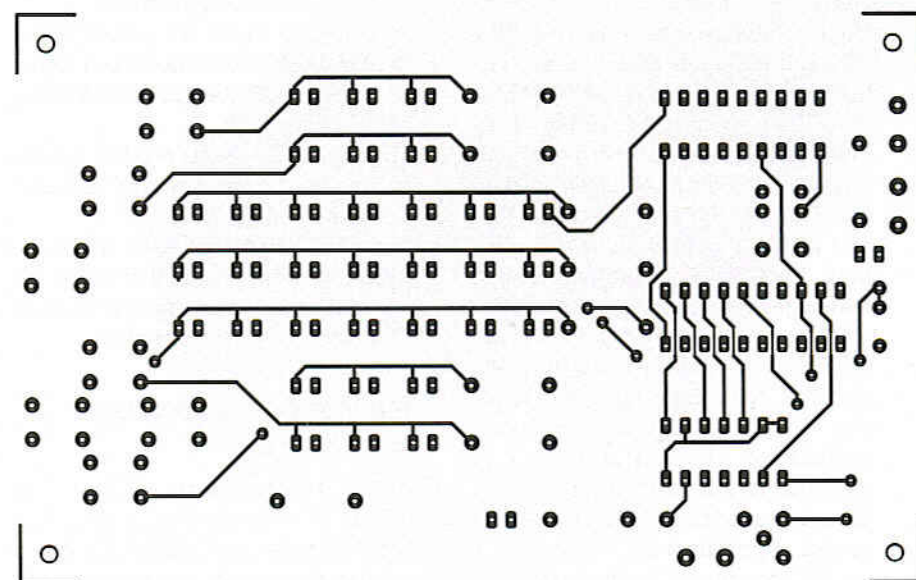
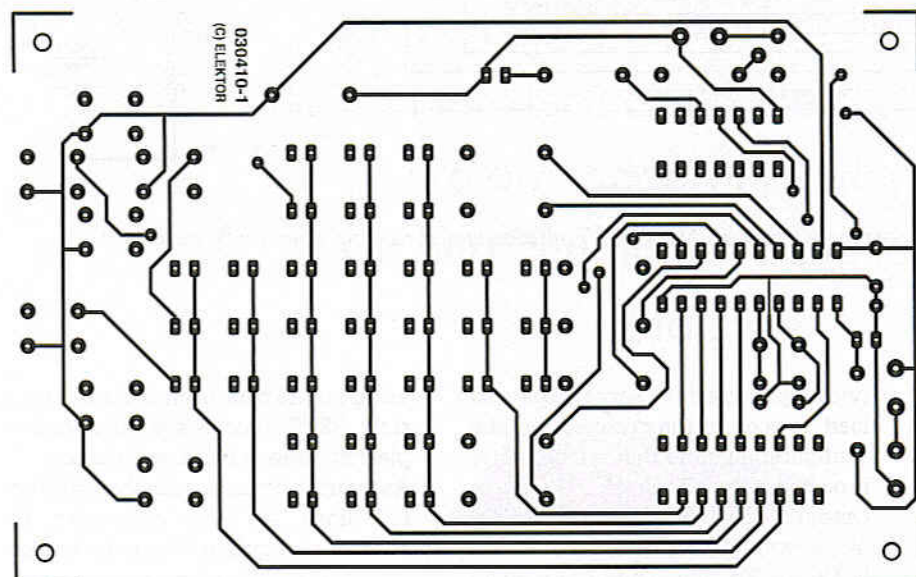
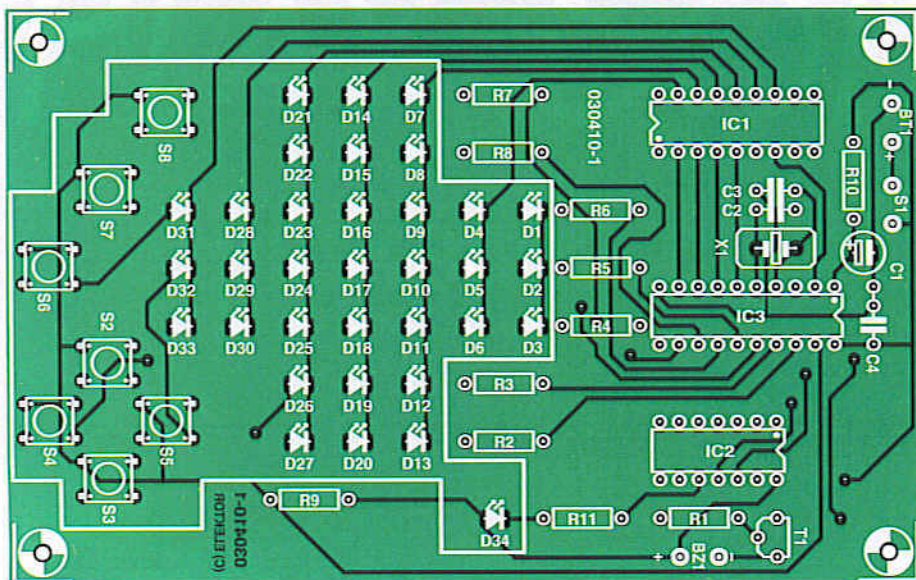


Figure 2. PCB designed for the Solitaire game.

## COMPONENTS LIST

### Resistors:

R1 = 1k $\Omega$   
 R2-R8 = 220 $\Omega$   
 R9 = 10k $\Omega$   
 R10, R11 = 1k $\Omega$

### Capacitors:

C1 = 1 $\mu$ F 16V, radial  
 C2, C3 = 22pF  
 C4 = 100nF

### Semiconductors:

D1-D34 = LED, 3mm, low current, red  
 T1 = BC547  
 IC1 = ULN2803  
 IC2 = 4023  
 IC3 = AT90S2313-10PC, programmed, order code **030410-41**

### Miscellaneous:

S1 = on/off switch, one contact  
 S2-S8 = pushbutton, PCB mount, 1 contact, 5mm, e.g., T60 (Conrad Electronics # 700479)  
 X1 = 4MHz quartz crystal  
 BZ1 = 5VDC (active) buzzer  
 BT1 = 2 x penlight (AA) battery with holder  
 Enclosure, e.g., Hammond type 1591DTRD (150 x 46 x 84mm)  
 PCB, ref. 030410-1, from The PCBShop

The aim of this game is to be left with as few pieces as possible at the end of the game. You can claim victory if you have only one piece left in the centre of the 'board'. As you will discover, that's very hard to do! So how do you arrive at this desired state?

When you turn the game on, there will be 32 LEDs lit up continuously and one, at the centre, flashing. The flashing LED shows your position on the board. The first step is to decide either to play your turn

## Project Downloads

AT90S microcontroller software.  
 File number: **030410-11.zip**

[www.elektor-electronics.co.uk/dl/dl.htm](http://www.elektor-electronics.co.uk/dl/dl.htm),  
 select month of publication.

where your piece is or to move the position of your piece. So how do you move your position should you wish to?

1. To move your position simply use the four direction switches S1-S4. You can move your position to wherever you like.
2. When you are positioned to where you want to be, press the SELECT button. The LED that you are positioned on will flash even faster. This means that you are in jump mode. To jump a piece, which must be next to yours — up, down, left or right, but not diagonal — press the appropriate direction switch. The piece you are positioned on will jump over that piece onto the space on the other side, and the jumped piece will disappear. You can only jump a piece if there is a space on the other side of that piece to be jumped, and if there is a piece where you are positioned. It is not always obvious if there is a piece where you are positioned, because the flashing LED looks the same whether it is just your position or whether you actually have a piece there. If the jump is requested and it is impossible, you will hear a beep. The jump mode will be cancelled for that move and you can then continue as before.

3. You continue this procedure until you can jump no more. The smaller the number of pieces left, the better. If (you think) a 'move' is no longer possible, then the player can press the STALEMATE button. Depending on the score, the buzzer will produce a number of beeps indicating your result:

- 1 beep = ≤ 10 remaining pieces
- 2 beeps = 8 remaining pieces
- 3 beeps = 4 remaining pieces
- 4 beeps = 1 remaining piece!

Where 'piece' should be taken to mean 'peg' or, in electronic parlance, 'LED'! In the assembly code listing, you'll find labels like 'bad\_luck', 'excellent', 'well done', 'very good' and 'good' to describe relevant routines.

## Construction

The game is built on a double-sided printed circuit board of which the

## Listing 1. LED control routine (AT90S program extract)

```

INIT_RED:
    LDI    TEMP, 0B11111111 ;7 BIT TABLE FOR 7X7 LED PATTERN
    STS    $60, TEMP      ;
    LDI    TEMP, 0B11111111
    STS    $61, TEMP      ;
    LDI    TEMP, 0B11111111
    STS    $62, TEMP      ;
    LDI    TEMP, 0B11110111
    STS    $63, TEMP      ;
    LDI    TEMP, 0B11111111
    STS    $64, TEMP      ;
    LDI    TEMP, 0B11111111
    STS    $65, TEMP      ;
    LDI    TEMP, 0B11111111
    STS    $66, TEMP      ;
    ;
    LDI    TEMP, $80      ;TERMINATOR
    STS    $67, TEMP      ;
    ;
    LDI    TEMP, $80      ;TEST
    STS    $68, TEMP      ;
    RET

;=====
REFRESH_RED:
    CLI
    PUSH    R27
    PUSH    R26
    ;
    LDI    R26, $60
    LDI    R27, $00
    LDI    COUNT1, 01
    RCALL  CONVERSION_ROUTINE
    ; INPUT IN COUNT3
    ; RESULT IN COUNT2
    ;
REFRESH_LOOP:
    CLR    TEMP          ;
    LD     TEMP, X+      ;GET RAM DATA AND INCREMENT POINTER
    CPI    R26, $68     ;END OF COLUMN?
    BREQ   EXIT_ROUTINE ;YES
    CPI    FLAG,1       ;NO
    BREQ   FLASHA       ;
    ;
    CP     COUNT1,COUNT2 ; COUNT1 = COUNT3 EFFECTIVELY
    BRNE  WRONG_ROW    ;
    EOR    TEMP,CURSOR  ;

WRONG_ROW:
FLASHA:
    OUT    PORTD, COUNT1 ;
    OUT    PORTB, TEMP   ;
    RCALL  DELAY         ;
    ; NOW SHIFT COUNT 'LEFT'
    ROL    COUNT1       ;
    RJMP  REFRESH_LOOP  ;

EXIT_ROUTINE:
    POP    R26           ;
    POP    R27           ;
    RET

```

copper track layout and component mounting plan are shown in Figure 2. The parts in the enclosed area (LEDs and pushbuttons)

should be mounted at the solder side of the board. You may want to do the same with the on/off switch, S1. This is necessary to allow the

board to be mounted as close as possible to the inside of the enclosure top panel (with appropriate cutouts for the switches). If you want to use solder pins for the battery connections, these are also best fitted at the solder side.

The photograph in **Figure 3** shows the board before it was fitted behind the opaque panel. The red filter enhances the visibility of the LEDs. Actually, that's achieved by making the board and the other component less visible!

## Software

The complete source code listing for the program executed by the AT90S micro is available free of charge from the Publishers' website at [www.elektor-electronics.co.uk](http://www.elektor-electronics.co.uk) as file number **030410-11.zip**.

The program listing is a good example of simple code with comment where necessary. An extract of the program appears in **Listing 1** — this part looks

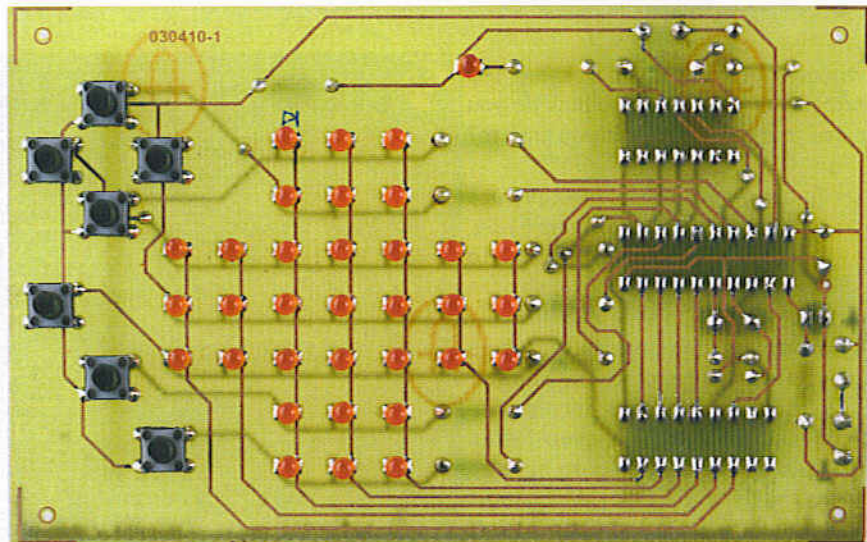


Figure 3. Completed board before mounting in the enclosure.

after the LED activity on the 'board'. Finally, those of you unwilling or unable to program your own micro for the project will like to know that the

AT90S2313 can also be bought ready-programmed from us under order code **030410-41**.

(030410-1)

Advertisement

## Forest Electronics – PIC and AVR ANSI C Compiler Products

FED's ANSI C Compiler for PIC or AVR processors

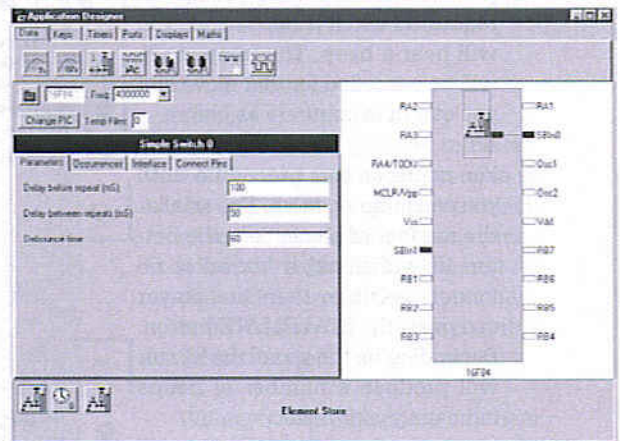
- Fully integrated editor with syntax highlighting, multiple pages etc.
- Full project support - include and manage multiple source files, simulator, assembler files and notes/comments within one project
- Fully integrated simulator and waveform analyser step from C line to C line, or examine code in assembler form. View device pins using a logic analyser application.
- Simulator supports LCD modules, keypad, buttons, LED's, displays, analogue inputs, serial and asynchronous data.
- Designed to ANSI C standards
- PIC - Supports 18xxx, 16xxx, 12xxx series 14 and 16 bit core processors
- AVR - Supports standard and MEGA core processors
- Generates MPLAB/AVR Studio projects and source files and completely standard hex output files.

Prices from £45.00 – [www.fored.co.uk](http://www.fored.co.uk) for full details.

### WIZ-C / AVIDICY

**Drag and Drop rapid application development using ANSI C for PIC and AVR**

- Rapid Application Development for the PIC or AVR microcontroller using the C language (WIZ- C for the PIC, AVIDICY for the AVR)
- Drag and drop your software component selections on to your design
- Included components support timers, serial interfaces, I2C, LCD, 7 Seg displays, keypads, switches, port controls, many bus interfaces including IIC and Dallas iButton, AVR/PIC Hardware, and more.
- Connect software components to MCU pins by point & click
- Parameters set from drop down list boxes, check boxes, or text entry
- Links your code automatically into library events (e.g. Button Pressed, Byte Received etc.)



- Automatically generates your base application including full initialisation, interrupt handling and main program loop
- The complete C Compiler and AVR Simulator programs are integrated into AVIDICY - total editing / compilation / assembly / simulation support in one program
- Also includes the Element Editor to enable you to create your own components with ease.
- Demonstration available from our web site

Prices from £50.00 - full details from [www.fored.co.uk](http://www.fored.co.uk)



### Forest Electronic Developments

12 Buldowne Walk, Sway  
LYMINGTON, Hampshire, SO41 6DU.  
01590-681511 (Voice/Fax)

Email –  
"info@fored.co.uk"



**Full details from - [www.fored.co.uk](http://www.fored.co.uk)**



### "Swordfish" PS40M10 Hand Held USB Oscilloscope

A unique hand held device that combines the functions of oscilloscope, data logger, spectrum analyser, volt meter and frequency meter in a single instrument. PS40M10 features a user replaceable precision spring loaded probe tip which can be used to probe even small smd components. The probe cap can be removed to allow PS40M10 to connect to standard oscilloscope probes or BNC cables if required. PS40M10 comes complete with oscilloscope and data logging software. The supplied Windows DLL's allows 3<sup>rd</sup> party applications to interface to it. Example code in several popular programming languages are provided. Windows CE and Linux drivers are also available on request.



#### "Swordfish" PS40M10 Features

- 10 Bit ADC Resolution
- 1G S/s sampling rate (repetitive) 40M S/s native
- Maximum input voltage +/- 50V
- AC / DC Coupling
- Edge, min/max pulse width and delayed trigger modes
- Analog Bandwidth 5MHz
- Self Powered USB Interface - no external PSU required
- Precision spring loaded probe tip or standard BNC connection
- 3<sup>rd</sup> Party application software support provided
- Hardware upgradeable over USB

£149  
+ shipping & VAT

£125  
+ shipping & VAT

### "Stingray" DS1M12 Dual Channel Oscilloscope, Signal Generator & Multi-Function Instrument

Stingray DS1M12 is the value for money dual channel oscilloscope with signal generator, data logger, spectrum analyser, volt meter and frequency meter capabilities. Despite its low cost, DS1M12 offers a wealth of features including 1M S/s sampling with 12 bit conversion, advanced digital trigger modes, AC / DC coupling and an inbuilt signal generator with 10 bit resolution.



#### "Stingray" DS1M12 Features

- Dual Channel standard BNC input connectors
- 12 Bit simultaneous ADC sampling on both channels
- 20M S/s sampling rate (repetitive) 1M S/s native
- Signal Generator Output / External Trigger Input
- Maximum input voltage +/- 50V
- AC / DC Coupling
- Edge, min/max pulse width and delayed trigger modes
- Analog Bandwidth 200KHz
- Self Powered USB Interface - no external PSU required
- 3<sup>rd</sup> Party application software support provided
- Hardware upgradeable over USB

#### Technical Information

For detailed technical specifications, information and downloads please visit [www.usb-instruments.com](http://www.usb-instruments.com)

#### Sales Information

USB Instruments - a division of EasySync Ltd  
373 Scotland Street, Glasgow G5 8QB, U.K.  
Tel : 0141 418 0181 Fax : 0141 418 0110  
E-mail : [sales@easysync.co.uk](mailto:sales@easysync.co.uk)  
Web : [www.easysync.co.uk](http://www.easysync.co.uk)

## FRUSTRATED!

Looking for ICs TRANSISTORS? A phone call to us could get a result. We offer an extensive range and with a worldwide database at our fingertips, we are able to source even more. We specialise in devices with the following prefix (to name but a few).



2N 2SA 2SB 2SC 2SD 2P 2SJ 2SK 3N 3SK 4N 6N 17 40 AD  
ADC AN AM AY BA BC BD BDT BDV BDW BDX BF  
BFR BFS BFT BFX BFY BLY BLX BS BR BRX BRY BS  
BSS BSV BSW BSX BT BTA BTB BRW BU BUK BUT BUY  
BUW BUX BUY BUZ CA CD CX CXA DAC DG DM DS  
DTA DTC GL GM HA HCF HD HEF ICL ICM IRF J KA  
KIA L LA LB LC LD LF LM M M5M MA MAB MAX MB  
MC MDAJ MJE MJF MM MN MPS MPSA MPSH MPSU  
MRF NJM NE OM OP PA PAL PIC PN RC S SAA SAB  
SAD SAJ SAS SDA SG SI SL SN SO STA STK STR STRD  
STRM STRS SV1 T TA TAA TAG TBA TC TCA TDA TDB  
TEA TIC TIP TIPL TEA TL TLC TMP TMS TPU U UA  
UAA UC UDN ULN UM UPA UPC UPD VN X XR Z ZN  
ZTS + many others

We can also offer equivalents (at customers' risk)

We also stock a full range of other electronic components  
Mail, phone, Fax Credit Card orders and callers welcome



## Cricklewood Electronics Ltd

40-42 Cricklewood Broadway London NW2 3ET  
Tel: 020 8452 0161 Fax: 020 8208 1441

## A QUANTUM LEAP IN EMBEDDED CONTROLLERS

# Quick FIRE

## SUPERCONTROLLERS

Our range provides:-

- The fastest 68000 based Core up to 66 Mhz.
- Extensive I/O:- Serial, IrDA, SPI, I<sup>2</sup>C, Analogue, Timers/Counters, RTC, etc.
- Large Memory Capacity:- Flash, SRAM, DRAM.
- Supports:- Mono & Colour LCD's, Touch Panels & Keypads, Very Low Power.

## ALSO LOW COST

### DEVELOPMENT

- Target easily & quickly.
- Full ANSI 'C' compiler, assembler & linker all Windows32 based.
- Source Level Debug.
- Full Driver Support with Libraries.
- Real Time Multitasking OS with a free run time licence.
- FREE Unlimited email support.

[www.cms.uk.com](http://www.cms.uk.com)

see our web site for full details

CAMBRIDGE MICROPROCESSOR SYSTEMS LTD



Unit 17-18 Zone 'D' Chelmsford Rd. Ind. Est.  
Great Dunmow, Essex CM6 1XG

Telephone: 01371 875644

email: [sales@cms.uk.com](mailto:sales@cms.uk.com)

# Altium FPGA LiveDesign Kit

## Designing with FPGAs

Paul Goossens

Modern circuits make ever more extensive use of FPGAs. Special software is required when designing with these devices. One of the companies that produces such software is Altium. In order to allow their software to be evaluated, they offer a cheap evaluation kit. Once the evaluation period has expired, the kit is still very useful as a development platform for your own designs!



Altium's background is that of a developer of various software products for electronics designers. Their product range contains, among other things, compilers for microcontrollers, schematic and PCB drawing software and FPGA design software. To allow their software to be evaluated, Altium has offered for some time now a development platform called nanoBoard together with an evaluation version of their software. Recently, they started offering a slimmed-down version of this board plus the above-mentioned software, which goes by the name of LiveDesign. This evaluation board costs 99 Euro (approx. £68) (excl. P&P). You get quite a bit for this money.

### Contents

The kit contains, in addition to the development board itself, a mains power adapter and a programming cable. There are also 2 ribbon cables included that

allow the I/O connectors of the board to be connected to your own expansion PCB. From the software perspective there are four CDs. These contain the evaluation software, examples and two presentations for Altium products. Finally, the box contains various items of documentation.

It is very important NOT to discard the docket on the packaging carton. This contains the customer number and release-code that you will need when installing the software.

This installation itself is very straightforward, but it is still useful to read through the installation instructions first. Especially since in addition to the Altium software, you will also need to install software from the manufacturer of the FPGA (depending on your choice this is either Altera or Xilinx).

### Hardware

The development board is provided with a number of

standard I/O features, such as we are accustomed to seeing on these kinds of boards (also refer to side bar). However one thing is striking, it is possible to adjust the corner frequency of the output filter of the DAC with a resistor array. The heart of the circuit is the FPGA, of course. Depending on your choice, this is either a Cyclone-FPGA (EP1C12F324C8) from Altera or a Spartan-3 (XC3S400-5FG456C) from Xilinx. As you will see shortly, these two FPGAs are very powerful!

Otherwise there is not much more to say about the hardware, except that with our board the wires between the speakers and the PCB had become disconnected. Fortunately, this was easily fixed with a little bit of soldering!

### Software

The accompanying software is an evaluation ver-

sion of the Protel/Nexar software suite from Altium. This version is time limited (30 days). Keep in mind that these 30 days start counting down from when the package is sent! It makes sense therefore, to install and try everything out immediately once you receive the package.

This software looks very polished and it is definitely worth the effort to try all its features. There are too many features for all of them to be described here. It is certainly no exaggeration to state that this software contains everything that is necessary to complete your own FPGA design from beginning to end. Even the firmware for so-called 'soft-core' processors can be developed with this software! While trying the various examples you will quickly become familiar with most of the functionality of this software.

In addition to the enclosed software, you will need to

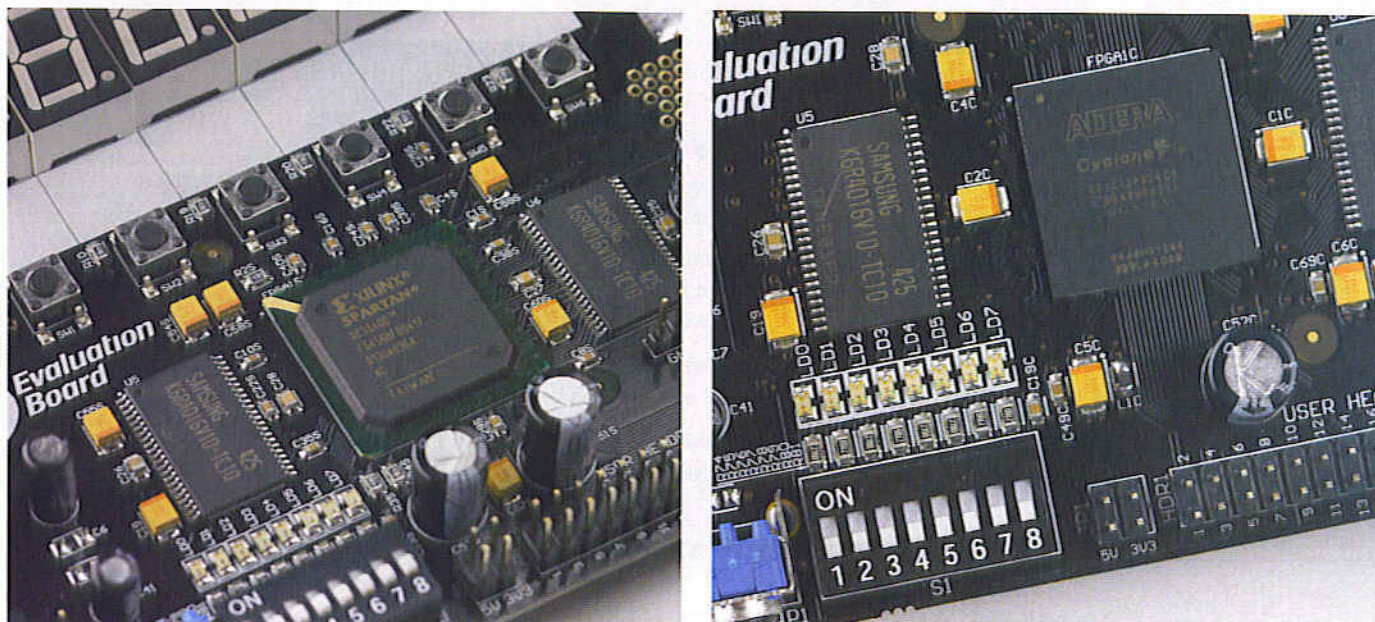


Figure 1. The board is available with two different types of FPGA.

install software from the FPGA manufacturer. If your board is fitted with a Xilinx FPGA, then you will need the free Web-ICE-Pack software. In the case of the Altera FPGA you will need the Quartus software (also a free download). With our [version of the software](#), the latest version of Quartus was not yet supported. On Altium's website you can find how to solve this problem very easily. It is only a case of tweaking a small text file. Very simple, but you just need to know how.

### Soft-core

This development kit is naturally accompanied by a number of examples. These can be roughly divided into 2 categories, namely pure hardware and soft-core-processor based designs. Before we go any further we will explain the term soft-core-processor.

A soft-core-processor is a micro-processor that is programmed inside an FPGA.

## Hardware Specifications

- FPGA choose between: Cyclone (Altera) **or** Spartan-3 (Xilinx)
- 2 x 512 Kbyte SRAM
- 6 x 7-segment display
- 6 pushbuttons
- 8-way DIP switch
- 8 LEDs
- TEST/RESET pushbutton
- system clock 50 MHz
- JTAG-interface
- 2 x I/O-connector with 20 unused I/O-signals
- RS232 connector
- 2 x PS/2 connection
- VGA output with R/2R-DACs
- stereo delta/sigma DACs
- line-out output
- headphone output (100 mW)

These processors are usually designed in a higher description language, such as VHDL or Verilog. An advantage is that any signal from inside the processor

can be examined and routed to the outside world. It is also not inconceivable to add some 'custom' instructions to the instruction set of the processor, just for this

particular application!

There are three different soft-core-processors among the examples. The TSK51 is an 8051-compatible processor, the TSK80 is compatible with the Z80 and finally there is the TSK165, which is compatible with the PIC16-series from Microchip.

In addition to the design of the processor, there is also the necessary firmware to set this processor to work. The software suite therefore also contains a C-compiler, which supports these processors. Designing hardware, software and now even your own processor can be done in just one software suite!

### Examples

The supplied examples range from simple to extremely complex. So there is something to appeal to anyone. There are examples that produce some simple effects using the LEDs, but there is also an example of a

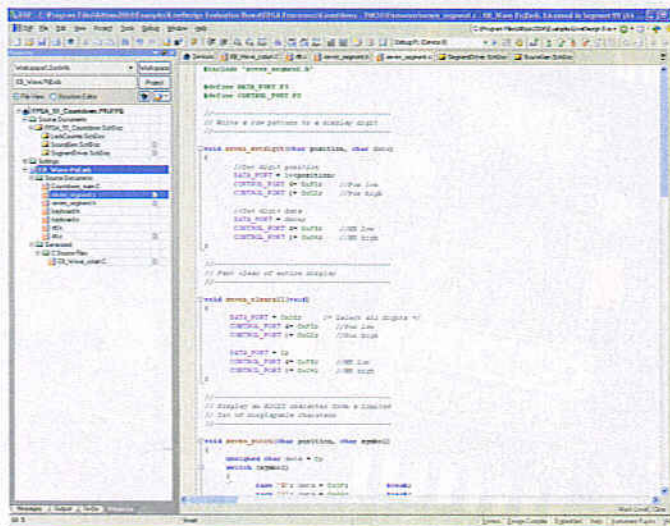


Figure 2. Working with the source code for a soft-core-processor.

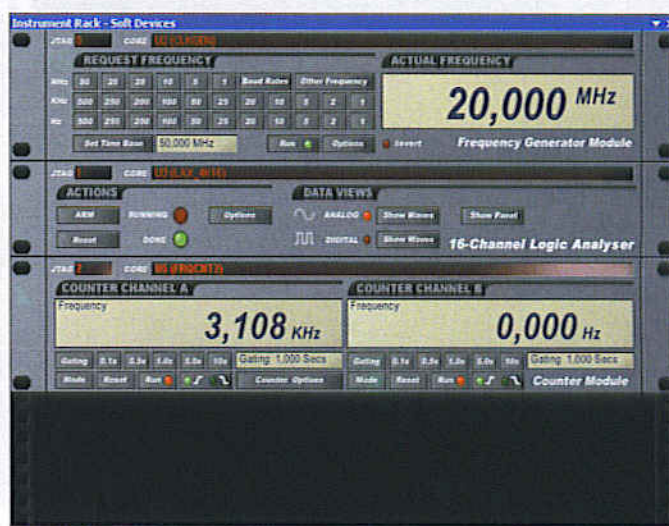


Figure 3. With these virtual instruments you can make measurements inside the FPGA.

complete 'Pacman' video game with PS/2-inputs for mouse and keyboard and a video output for the screen!

There are also some intermediate complexity examples such as a clock with alarm function.

To get an impression of the scale of the designs in the FPGA, we compiled an included example that contains no less than 4 processors (TSK165). Then we looked at a report from the compiler software and it appeared that this design used only about 1/3 of the available resources of the FPGA!

All examples can be programmed in the FPGA after compilation and be tested directly on the board.

### Debugging

The real power of the software is really only utilised when you want to carry out measurements on your design. It is obviously impossible to measure internal signals of the FPGA with

a probe, so most examples are provided with a JTAG interface.

With this you can (without disturbing the operation) make real-time measurements inside the FPGA. For this purpose, several measuring instruments are built into the software. A logic analyser, an oscilloscope (digital, obviously) and some I/O-blocks that let you determine logic levels with some buttons.

To make this all complete, there is the possibility to debug the processors with their firmware. Registers can be changed, breakpoints can be placed, memory can be examined, etc. All this can be done!

### Finally

This FPGA development kit offers much for the money. Unfortunately the software is no longer usable after 30 days. However, you can continue to use the board in combination with the free

software from the FPGA chip manufacturers. Although, it will take a little getting used to after having been spoiled with the software suite from Altium.

The diagram for the design-kit is supplied as a Protel schematic file. This means that after the end of the evaluation period the schematic cannot be viewed again. If you would like to continue to use the board after the software has expired it makes sense to print the schematics early on. Without these schematics it is not easy to figure out which pins from the FPGA are connected to what sections of hardware and connectors!

Purchasing this software is not really in the league of the average hobbyist (both parts of the software together cost around 10,000 Euro!). The free software from the FPGA manufacturers, however, is still very usable to realise your own designs

with this kit, after the 30-day period.

Because an FPGA with sufficient capacity has been used, it is not very likely that your design won't fit in this device. Furthermore, the FPGAs are so quick that it has become relatively easy to design complex and fast equipment at home. The nicest aspect of this is that when changing the design there is no need to immediately reach for the soldering iron. A simple button push is sufficient, the rest is carried out by the PC and hardware.

This development kit offers more than enough possibilities to begin exploring and experimenting with FPGAs. You will quickly be surprised as to what you can do with it!

(040414-1)

### Internet links

- [www.altium.com](http://www.altium.com)
- [www.altera.com](http://www.altera.com)
- [www.xilinx.com](http://www.xilinx.com)

## What are FPGAs?

FPGA stands for Field Programmable Gate Array. These are chips that are provided with a large number of small digital building blocks, each of which can perform a simple function. The inputs and outputs from these building blocks can be connected to inputs and outputs from other blocks via a matrix of signal lines, hence the term Gate Array.

When the power is first turned on, the inputs and outputs are disconnected from the signal matrix. The chip can be programmed via a programming port. This means that the designer, with the aid of a programming file, determines which inputs and outputs are connected to each other, so that the chip will perform a certain function.

It is easy to imagine the FPGA as a (very) large experimenting board with tens of thousands (or even hundreds of thousands) of logic ICs, which are not interconnected. Connections are made between these chips according to the wishes of the designer.

An advantage of an FPGA is that all these building block are on one piece of silicon and that each building block has a very high propagation speed (in the order of a few nanoseconds). This means that very fast digital circuits can be realised with an FPDA, which cannot be done with a handful of logic ICs.

FPGAs are often also provided with a number of additional features, such as block of memory, hardware multipliers, etc. Some FPGAs also contain a built-in processor that can be connected with the design in the FPGA.

Depending on the capabilities of the FPGA, it can sometimes be difficult (as we described in this article) to implement and apply your own processor in an FPGA!

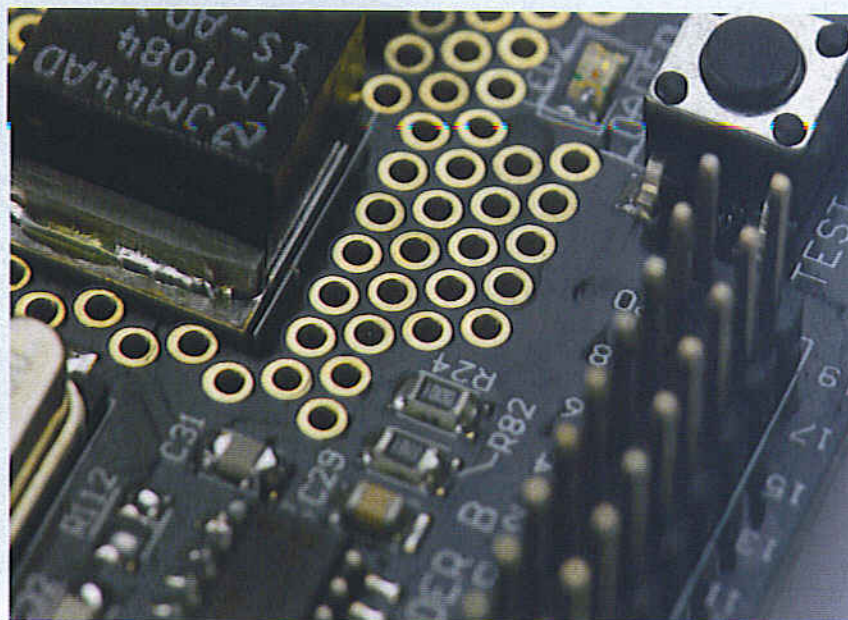
## Personal ideas

In the process of authoring this article I've gradually become very enthusiastic about the possibilities for this board. One of my hobbies (in addition to electronics, of course) is building and flying model aeroplanes.

As it happens, I have a nice aeroplane that has a reasonably spacious fuselage, which accommodates this board easily. Originally I had the idea of fitting a camera with accompanying transmitter in there, so that I could see from the ground on a TV the world from the cockpit of my model aeroplane.

Afterwards I wanted to add all sorts of bells and whistles.

While experimenting with this board from Altium, I noticed how powerful the FPGA is that has been used here. That's why I immediately took up the plan to go a little further, namely converting the video signal from the camera to a digital signal with a video decoder and send it to the FPGA. In addition I would like to place a number of sensors for measuring the air pressure (i.e. height and vertical speed) and motor temperature, and possibly a GPS module to determine the position. This information is also (in digital form) sent to the FPGA. The FPGA will then combine the measurement data with the camera signal and send the output video signal first to an encoder and then to the transmitter. In this way I cannot only see the real-time picture from the cockpit but also see various relevant data at the same time!



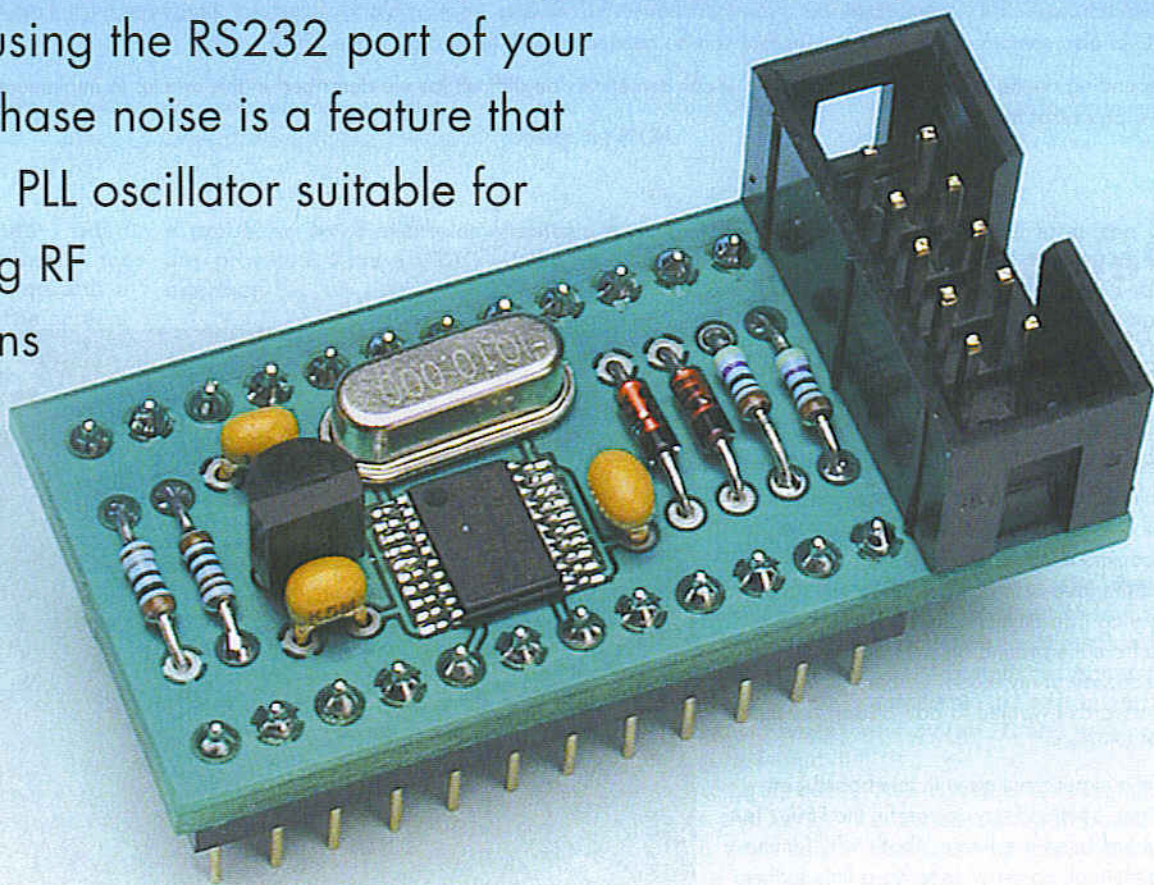
Who knows, maybe I will even fit an autopilot in my aeroplane. That would make my hobby a lot cheaper!

# Serially Programmable

## Compact and universal

Burkhard Kainka

The right crystal controlled frequency at the right time: With this DIP outline oscillator there's no need to wait for a special crystal to be made up. You can program its frequency precisely using the RS232 port of your PC. Low phase noise is a feature that makes this PLL oscillator suitable for demanding RF applications also.



This multipurpose clock generator circuit uses the CY27EE16 programmable oscillator of the CyberClock family of devices from Cypress. Regular readers will remember this chip from the November 2004 issue of *Elektor Electronics*. The entire oscillator circuit shown in **Figure 1** comprises of little

more than the clock generator chip together with a voltage regulator and fits neatly onto a small PCB. Altogether it makes an extremely versatile clock generator that will no doubt find a use in many applications. The 10 MHz reference crystal shown in the parts list is fitted to the PCB via a

socket. A different value may be substituted if it is necessary to provide two or more specific output frequencies simultaneously for a particular application.

The chip communicates with the PC over an I<sup>2</sup>C bus using handshake signals of the RS232 computer interface.

# Crystal Oscillator

Data from the slave is read on the CTS line. The signals DTR and RTS are read by DCD and DSR and these may be used later in software for possible expansion of the design, they are also used to control the data rate in a USB/RS232 adapter.

The software allows the user to load settings to the internal EEPROM or RAM register. In many applications the oscillator chip will be built into equipment and its clock frequency parameters will be programmed in the EEPROM. It will always be possible to change the value later if the frequency needs to be altered. In other cases where the application calls for the output frequency to be selectable the connection cable will remain attached to the PC and new data can be sent to the clock chip whenever necessary. The PCB is the same outline as a 24 pin DIL IC. Two rows of pins can be fitted to allow the assembly to be plugged into a standard 24 pin IC socket. A

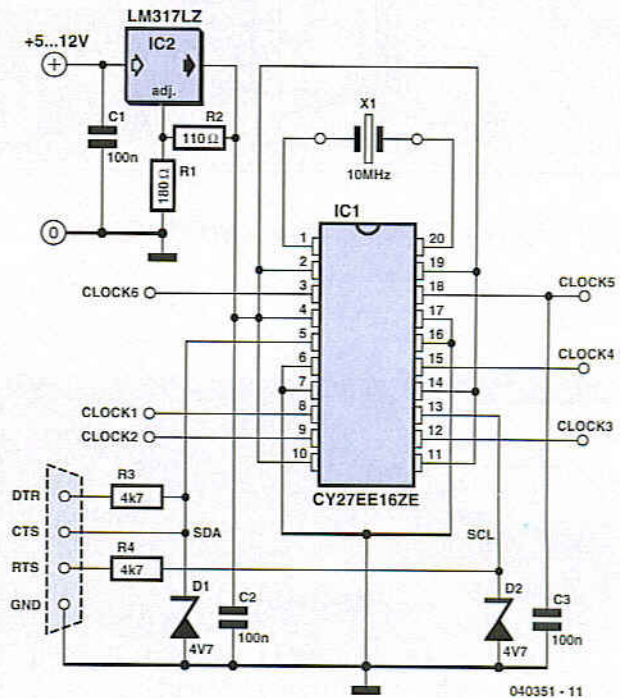


Figure 1. The programmable clock circuit diagram.

## COMPONENTS LIST

### Resistors:

R1 = 180Ω  
R2 = 110Ω  
R3, R4 = 4kΩ7

### Capacitors:

C1, C2, C3 = 100nF ceramic

### Semiconductors:

IC1 = CY27EE16ZE  
IC2 = LM317LZ, TO92  
D1, D2 = Zener diode 4.7V 0.5W

### Miscellaneous:

10.0MHz quartz oscillator module with socket  
10-way boxheader  
10-way flatcable with IDC socket and 9-way sub-D socket  
PCB, ref. 040361-1 from The PCBShop

### Note:

Ready populated and tested boards as well as bare boards available from AK-Modul-Bus GmbH, Germany  
[www.ak-modul-bus.de](http://www.ak-modul-bus.de).

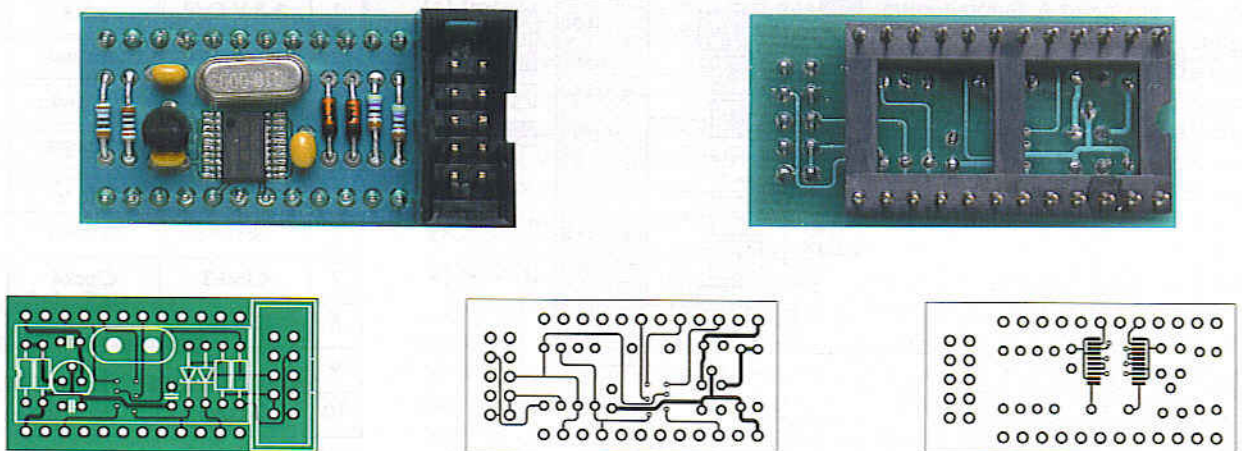


Figure 2. The PCB is arranged as a 24 pin DIP outline.

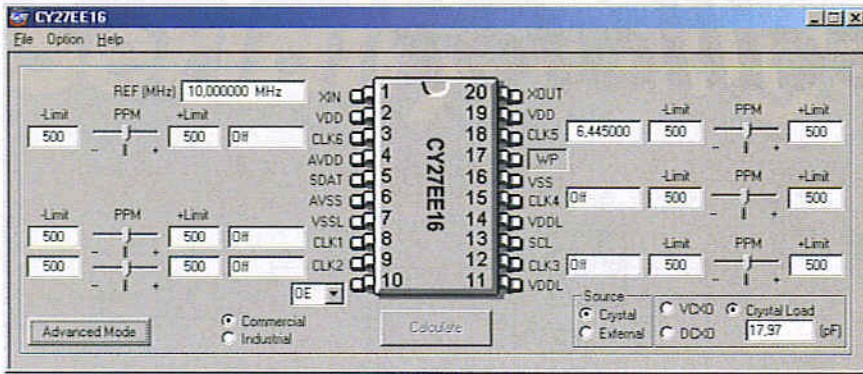


Figure 3. Frequency setting using CyberClocks.

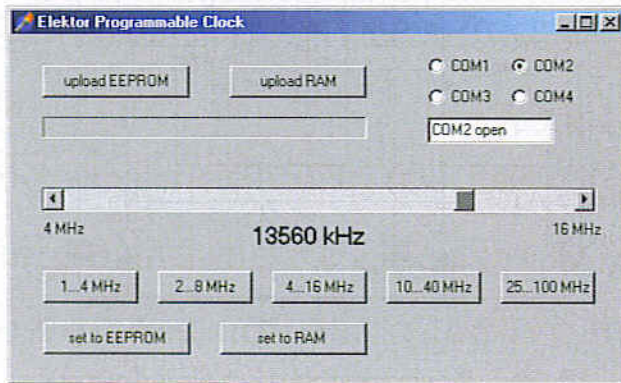


Figure 4. The Clock.exe program.

10-way upright connector, accept the cable connecting it to the PC. This is not too much of a problem because the cable is only needed when the oscilla-

tor requires reprogramming. The data and clock signals to the CY27EE16 are also connected to pins on the IC socket so that an on-board processor in the

target system with suitable software routines could reprogram the clock generator directly. Table 1 shows the pin-out assignments of the 24-pin socket.

Assembling the components onto the PCB should not be too much of a problem for anyone with a little experience in mounting SMD components. One method using generous amounts of solder and desoldering braid to clean up has often been described in *Elektor Electronics*. When the finished PCB is connected to a suitable power supply a voltage of 3.3 V can be measured on the CY27EE16 supply pins and the crystal should be oscillating. All signal output pins will however be set to high impedance mode until the chip is programmed.

The program *Clock.exe* together with some helpful examples can be downloaded free of charge from the *Elektor Electronics* web site [www.elektor-electronics.co.uk](http://www.elektor-electronics.co.uk). The file number is 040351-11.zip. For complete chip programming flexibility it will also be necessary to download the *CyberClocks* program and this can be found at [www.cypress.com](http://www.cypress.com).

## Change the settings with CyberClocks

All the configuration data for the chip can be programmed using *CyberClocks*. It is necessary to specify the reference crystal frequency and also which output pin (or pins) will be used and the desired output frequency. Figure 3 shows an example using the

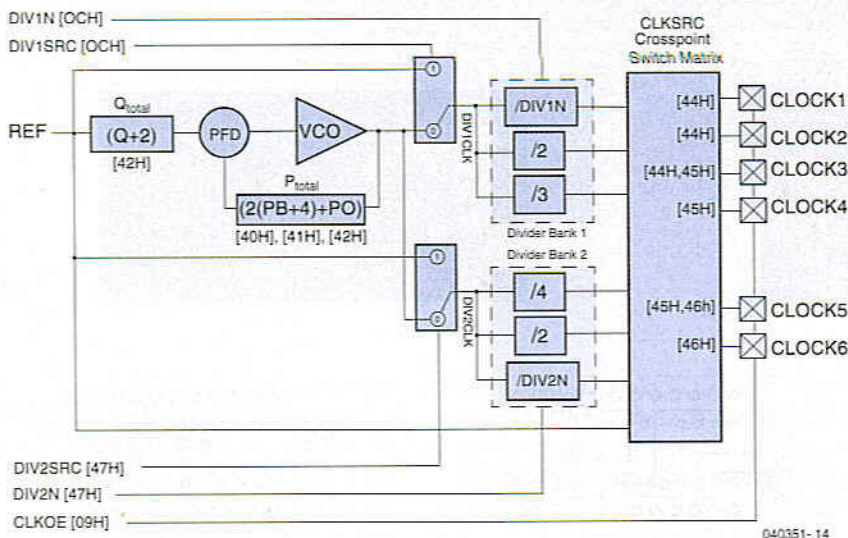


Figure 5. The programmable divider and register.

Table 1. Pin-out assignments for the oscillator PCB.

| Pin | Signal    | Signal | Pin |
|-----|-----------|--------|-----|
| 1   | 3.3 V O/P | +5 V   | 24  |
| 2   | Ground    | Ground | 23  |
| 3   | Clock1    | Clock6 | 22  |
| 4   | Ground    | Ground | 21  |
| 5   | Clock2    | Clock5 | 20  |
| 6   | Ground    | Ground | 19  |
| 7   | Clock3    | Clock4 | 18  |
| 8   | Ground    | Ground | 17  |
| 9   | SCL       | Ground | 16  |
| 10  | Ground    | Ground | 15  |
| 11  | SDA       | Ground | 14  |
| 12  | Ground    | Ground | 13  |

CLK 5 output. Information containing all register values and settings are stored as a binary file in the PC and downloaded to the chip.

## Data transfer using Clock.exe

The *Clock.exe* program writes data into either the internal EEPROM of the CY27EE16 or into RAM. The register contents in RAM become immediately effective whereas the settings stored to non-volatile EEPROM will only become effective after the chip undergoes its next power up when all EEPROM data will be written to RAM. The software includes some example files to generate different frequency outputs from a 10-MHz reference clock. The buttons labelled 'upload EEPROM' and 'upload RAM' transfer the binary file generated in the Cypress *CyberClocks* program. In the lower part of the program window there is possibility to directly change the frequency settings without recourse to the *CyberClocks* program. It is assumed that a 10 MHz crystal is used and a sample file with the desired output configuration has already been loaded. *Clock.exe* does not change all the registers but just programs new values to the PLL and the 7-bit divider DIV1N for divider bank 1. The maximum PLL range from 100 MHz to 400 MHz is used with the smallest step change of 250 KHz. The different output frequency ranges are produced by the post divider and give the following step changes in output frequency:

| Output frequency in MHz | Steps in kHz |
|-------------------------|--------------|
| 1 to 4                  | 2.5          |
| 2 to 8                  | 5            |
| 4 to 16                 | 10           |
| 10 to 40                | 25           |
| 25 to 100               | 62.5         |

## Multiple clock sources from one oscillator

The *cyberclock* clock generator has six frequency outputs and its important to understand how the internal divider arrangement places limita-

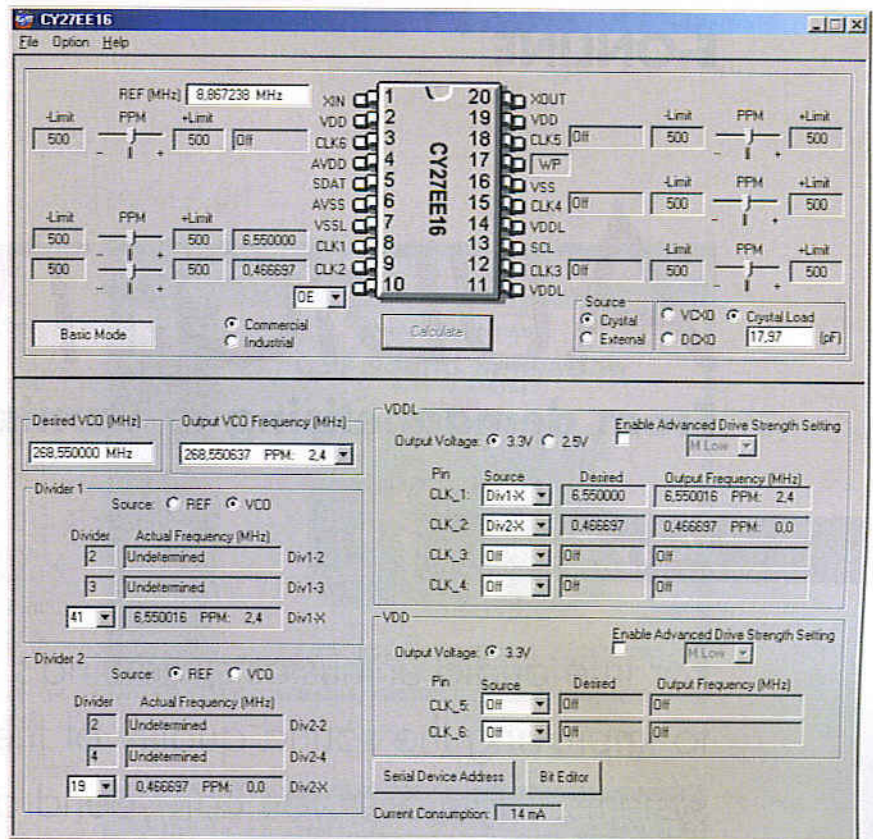


Figure 6. Advanced Mode settings.

tions on programming the output frequencies. There are two 7-bit programmable internal divider banks that can be configured to divide down the output of the crystal or the PLL. Two alternative dividers in each bank offer fixed division ratios. The PLL output can for example be made available on three output pins, the first pin will be the PLL frequency divided by 127, the second will be the PLL frequency divided by 2 and the third will be divided by 3. The other divider bank can be used to divide the crystal frequency. A more detailed description can be found in the data sheet from Cypress.

In a typical RF application there is often the need for more than one frequency source in the whole system. The CY27EE16 contains only one PLL but it can generate several different frequencies if the crystal frequency is chosen carefully. Figure 5 shows an example where two oscillator frequencies are produced by the clock generator for a DRM type receiver. The desired second oscillator frequency of 467 KHz is achieved with a deviation of 300 Hz using a division factor of 19 after the crystal

oscillator. The first oscillator frequency uses the PLL and achieves the desired frequency of 6550 KHz with an offset of just 16 Hz.

The *Cyberclock* also allows fine adjustment of the crystal frequency with a programmable load capacitor. Its value can be adjusted in the range from 7.8 pF to 32 pF in steps of 0.1 pF. To try out this feature the author required a highly stable precise frequency of 45.012 MHz for a receiver with a 45 MHz crystal filter to give a 12 kHz output signal. A rummage around the spares box soon provided a number of suitable crystals and with the help of the calculator it was determined that a standard 8.867238 MHz PAL crystal would again be suitable and would provide an output frequency closest to the required signal.

The frequency difference was only – 210 Hz or 4.7 ppm. The crystal would only need to be 'pulled' by 40 Hz to achieve exactly the required output frequency. This last adjustment was made using the time-honoured principle of trial and error and the final 'trimmer' value was found to be 22 pF.

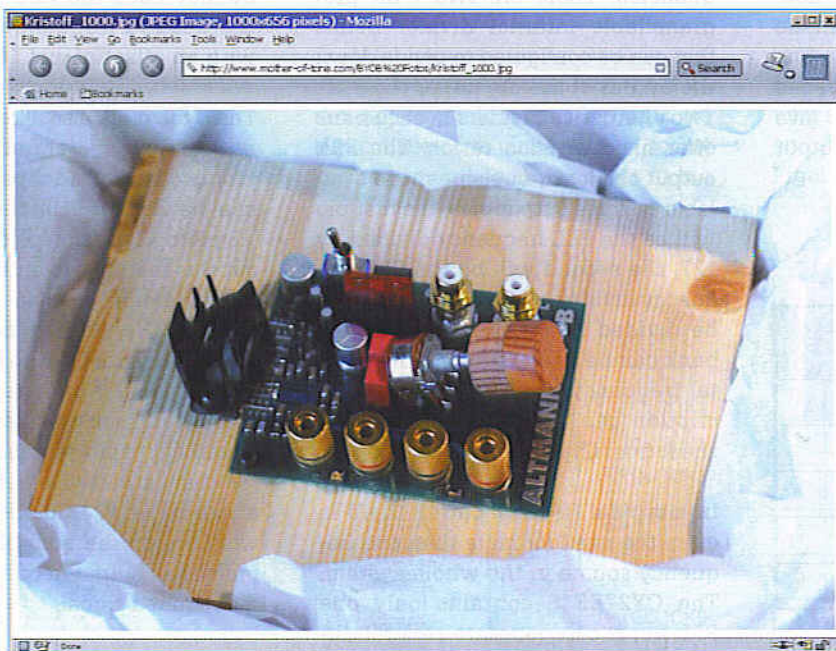
(040351-1)

# AUDIO-TWEAKS

From demagnetising to varnishing

Harry Baggen

For true audio enthusiasts, nothing's too far out when it comes to improving the sound quality of their hi-fi or surround-sound systems. Naturally, you can spend a lot of money on cables and other accessories, but there are a lot of possibilities that go even further, such as equipment modifications and special treatments for LPs and CDs.



Despite the mountains of cheap audio equipment sold every year, there is still a sizable group of people devoted to true hi-fi reproduction in both stereo and surround-sound versions. Many of these confirmed high-enders even resort to rather unusual methods to squeeze the last drop of performance out of their gear and obtain just a smidgen more detail from the speakers. Here we have collected several of these methods, which

range from quite serious to rather questionable.

Let's start off with a few in the latter category. There are various tips going around for making CDs sound better. For instance, it's supposed to help if you put the CD in the freezer for a few hours before playing it. That doesn't cost anything, so it's easy to try it out. Another way to improve the sound of a CD is to

demagnetise it before you play it. Several manufactures market commercial devices for this purpose.

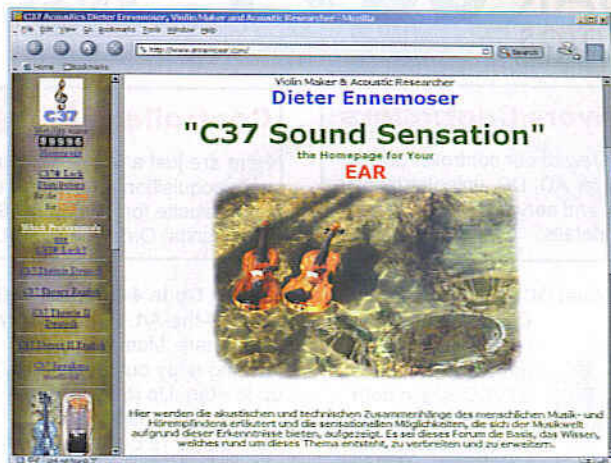
One of the strangest tricks for improving the sound of a CD is one that we recently found on the **Audio Tweaks** website [1]. There someone recommends spraying a bit of Pledge (a sort of wax polish for wooden furniture) into the air and then dragging the data side of the CD

through the aerosol fog hanging in the air [2]. That will cause microscopic drops of liquid to adhere to the surface of the CD, which apparently affects the playback. This seems rather risky to us from a technical viewpoint, since residues of the polish will most likely be spun off from the CD and end up in the drive, and that can have disastrous consequences for the laser and the slide mechanism. At least you can't say we didn't warn you. This site has a collection of more than 300 audio tweaks, and it's quite amusing to browse through them.

Another rather unusual tip involves 'C37 lacquer', a sort of magic potion formulated by the Austrian violin maker **Dieter Ennemoser** [3]. It's a sort of violin varnish that also appears to have special properties for audio equipment, and everything that is coated with it will only vibrate at natural harmonic frequencies (based on carbon at a body temperature of 37 °C – hence the name). We must admit that if you coat your speaker cones with this stuff, it's bound to affect the sound quality. Herr Ennemoser's site also has various links to sites with descriptions of treating amplifiers and the like with this varnish. Even coating the ICs on a circuit board is supposed to lead to a perceptible improvement in sound quality. But you should first read what various people have to say and draw your own conclusions. The activities the American company **CyroPlus** [4] are less strange, and they also have a technical explanation. What they do is to chill interconnecting cables and speaker cables, as well as individual valves and ICs or even entire circuit boards, down to absolute zero. The idea behind this is that it restores the original crystalline structure of the materials in the cables or components. You can buy treated cables from them, but you can also place an order to have your own cables chilled. The prices are quite reasonable, aside from the cost of shipping to the US.

It used to be that tuning or tweaking hi-fi equipment was primarily something done by hobbyists, but in the meantime it has turned into a professional business. Well-known companies, such as **Van Medevoort** [5] in the Netherlands and **Swoboda Audio** [6] in Germany, offer modified consumer equipment with all sorts of tweaks, such as optimising the damping of the enclosure, upgrading the power supply, or modifying subcircuits (such as using special opamps in a CD output stage). There's no doubt that such extensive measures definitely affect the sound quality and can yield very good end results. In most cases, though, it's a costly enterprise, since it takes a lot of work and time to modify an existing piece of equipment.

Finally we have a nice idea for the minimalists among our hi-fi enthusiasts. When you think of a hi-fi amplifier, you usually think of a big box with a hefty power supply (and just now we want to leave aside controversial issues such as how much feedback gives the best results). Under the motto 'keep the circuitry and circuit-board tracks between the input and output of the amplifier to a minimum', the German **Charles Altmann** [7] has created an amplifier stage consisting of nothing more than a power IC on a circuit board with input and output sockets



and a potentiometer. It bears the suggestive name 'BYOB amplifier', and the circuit is powered by a car battery. As Altmann finds that a metallic enclosure generates undesirable vibrations, the amplifier is supplied on a small, nicely finished wooden board. The photos on his website should inspire quite a few audio enthusiasts to make something similar on their own. As you can see, hi-fi is truly an open-ended subject!

(045111-1)

## Internet addresses

- [1] Audiotweaks: [www.audiotweaks.com/collection\\_ascend.htm](http://www.audiotweaks.com/collection_ascend.htm)
- [2] Pledge-tip: [www.audiotweaks.com/tweaks/tweak\\_265.htm](http://www.audiotweaks.com/tweaks/tweak_265.htm)
- [3] Dieter Ennemoser: [www.ennemoser.com/](http://www.ennemoser.com/)
- [4] CryoPlus: [www.cryoplus.com/audio.html](http://www.cryoplus.com/audio.html)
- [5] Van Medevoort upgrades: [www.audioart.nl/nl/upgrade.html](http://www.audioart.nl/nl/upgrade.html)
- [6] Swoboda Audio: [www.swobodaaudio.de/](http://www.swobodaaudio.de/)
- [7] BYOB amplifier: [www.mother-of-tone.com/byob.htm](http://www.mother-of-tone.com/byob.htm)



Quasar Electronics Limited  
PO Box 6935, Bishops Cleeve, Stortford,  
CM23 4WP  
Tel: 0870 246 1826  
Fax: 0870 460 1045  
E-mail: sales@quasarelectronics.com

Add £2.95 P&P to all UK orders or 1st Class Recorded - £4.95,  
Next Day (insured £250) - £7.95, Europe - £6.95, Rest of World - £9.95  
(order online for reduced price UK Postage).  
We accept all major credit/debit cards. Make cheques/PO's payable to  
Quasar Electronics. Prices include 17.5% VAT.  
Call now for our FREE CATALOGUE with details of over 300 kits,  
projects, modules and publications. Discounts for bulk quantities.  
MAIL ORDER ONLY.



**QUASAR**  
electronics  
Helping you make the right connections!

**0871**

**CREDIT CARD  
SALES**

**717 7168**

### Motor Drivers/Controllers

Here are just a few of our controller and driver modules for AC, DC, unipolar/bipolar stepper motors and servo motors. See website for full details.

#### NEW! Bidirectional DC Motor Controller

Controls the speed of most common DC motors (rated up to 32VDC/5A) in both the forward and reverse direction. The range of control is from fully OFF to fully ON in both directions. The direction and speed are controlled using a single potentiometer. Screw terminal block for connections.  
Kit Order Code: 3166KT - £14.95  
Assembled Order Code: AS3166 - £24.95



#### DC Motor Speed Controller (5A/100V)

Control the speed of almost any common DC motor rated up to 100V/5A. Pulse width modulation output for maximum motor torque at all speeds. Supply: 5-15VDC. Box supplied. Dimensions (mm): 60Wx100Lx60H.  
Kit Order Code: 3067KT - £12.95  
Assembled Order Code: AS3067 - £19.95



#### NEW! PC / Standalone Unipolar Stepper Motor Driver

Drives any 5, 6 or 8-lead unipolar stepper motor rated up to 6 Amps max. Provides speed and direction control. Operates in stand-alone or PC-controlled mode. Up to six 3179 driver boards can be connected to a single parallel port. Supply: 9V DC. PCB: 80x50mm.  
Kit Order Code: 3179KT - £9.95  
Assembled Order Code: AS3179 - £16.95  
Assembled Order Code: AS3113 - £24.95



#### NEW! Bi-Polar Stepper Motor Driver

Drive any bi-polar stepper motor using externally supplied 5V levels for stepping and direction control. These usually come from software running on a computer. Supply: 8-30V DC. PCB: 75x85mm.  
Kit Order Code: 3158KT - £12.95  
Assembled Order Code: AS3158 - £26.95



Most items are available in kit form (KT suffix) or assembled and ready for use (AS prefix).

### Controllers & Loggers

Here are just a few of the controller and data acquisition and control units we have. See website for full details. Suitable PSU for all units: Order Code PSU445 £8.95

#### Rolling Code 4-Channel UHF Remote

State-of-the-Art. High security. 4 channels. Momentary or latching relay output. Range up to 40m. Up to 15 Tx's can be learnt by one Rx (kit includes one Tx but more available separately). 4 indicator LED's. Rx: PCB 77x85mm, 12VDC/6mA (standby). Two and Ten channel versions also available.  
Kit Order Code: 3180KT - £41.95  
Assembled Order Code: AS3180 - £49.95



#### Computer Temperature Data Logger

4-channel temperature logger for serial port. °C or °F. Continuously logs up to 4 separate sensors located 200m+ from board. Wide range of free software applications for storing/using data. PCB just 38x38mm. Powered by PC. Includes one DS1820 sensor and four header cables.  
Kit Order Code: 3145KT - £19.95  
Assembled Order Code: AS3145 - £26.95  
Additional DS1820 Sensors - £3.95 each



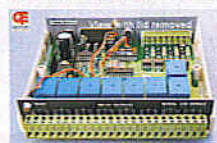
#### NEW! DTMF Telephone Relay Switcher

Call your phone number using a DTMF phone from anywhere in the world and remotely turn on/off any of the 4 relays as desired. User settable Security Password, Anti-Tamper, Rings to Answer, Auto Hang-up and Lockout. Includes plastic case. Not BT approved. 130x110x30mm. Power: 12VDC.  
Kit Order Code: 3140KT - £39.95  
Assembled Order Code: AS3140 - £49.95



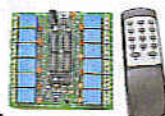
#### Serial Isolated I/O Module

Computer controlled 8-channel relay board. 5A mains rated relay outputs. 4 isolated digital inputs. Useful in a variety of control and sensing applications. Controlled via serial port for programming (using our new Windows interface, terminal emulator or batch files). Includes plastic case 130x100x30mm. Power Supply: 12VDC/500mA.  
Kit Order Code: 3108KT - £54.95  
Assembled Order Code: AS3108 - £64.95



### Infrared RC Relay Board

Individually control 12 on-board relays with included infrared remote control unit. Toggle or momentary. 15m+ range. 112x122mm. Supply: 12VDC/0.5A  
Kit Order Code: 3142KT - £41.95  
Assembled Order Code: AS3142 - £51.95



### PIC & ATMEL Programmers

We have a wide range of low cost PIC and ATMEL Programmers. Complete range and documentation available from our web site.

#### Programmer Accessories:

40-pin Wide ZIF socket (ZIF40W) £15.00  
18V DC Power supply (PSU010) £19.95  
Leads: Parallel (LDC136) £4.95 / Serial (LDC441) £4.95 / USB (LDC644) £2.95

#### NEW! USB 'All-Flash' PIC Programmer

USB PIC programmer for all 'Flash' devices. No external power supply making it truly portable. Supplied with box and Windows Software. ZIF Socket and USB Plug A-B lead not incl.  
Kit Order Code: 3128KT - £34.95  
Assembled Order Code: AS3128 - £44.95



#### Enhanced "PICALL" ISP PIC Programmer

Will program virtually ALL 8 to 40 pin PICs plus a range of ATMEL AVR, SCENIX SX and EEPROM 24C devices. Also supports In System Programming (ISP) for PIC and ATMEL AVRs. Free software. Blank chip auto detect for super fast bulk programming. Requires a 40-pin wide ZIF socket (not included). Available in assembled format only.  
Assembled Order Code: AS3144 - £49.95



#### ATMEL 89xxxx Programmer

Uses serial port and any standard terminal comms program. 4 LED's display the status. ZIF sockets not included. Supply: 16-18VDC.  
Kit Order Code: 3123KT - £29.95  
Assembled Order Code: AS3123 - £34.95



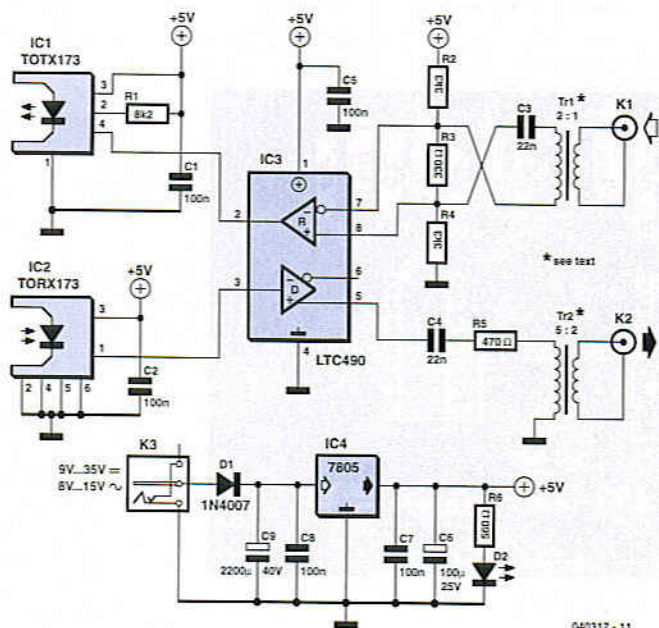
#### NEW! USB & Serial Port PIC Programmer

USB/Serial connection. Header cable for ICSP. Free Windows software. See website for PICs supported. ZIF Socket/USB Plug A-B lead extra. Supply: 18VDC.  
Kit Order Code: 3149KT - £34.95  
Assembled Order Code: AS3149 - £49.95

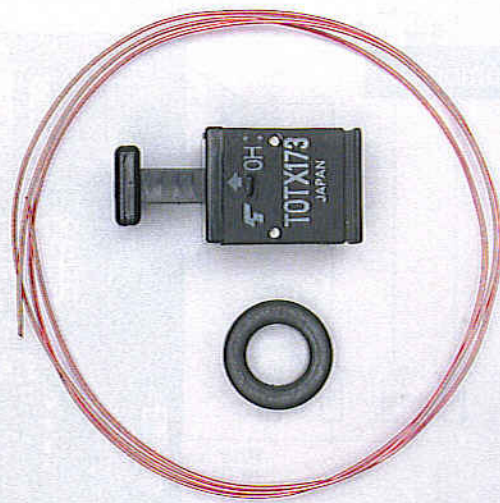


[www.quasarelectronics.com](http://www.quasarelectronics.com)

Secure Online Ordering Facilities • Full Product Listing, Descriptions & Photos • Kit Documentation & Software Downloads



040317-11



## Bidirectional S/PDIF Converter

Joseph Kranz

Although S/PDIF is the standard when it comes to conveying digital audio signals in consumer electronics equipment, difficulties may be encountered if you try to connect up two apparatus having digital connections. Cheap equipment usually has only one connection (coaxial or optical), while more up-market products will generally offer both variants. When interconnecting CD and DVD players, MD recorders and surround receivers you'll soon find that a converter from optical to coaxial or the other way around is useful if not indispensable.

The bidirectional (two-way) S/PDIF converter shown here employs just one IC to handle the conversion both ways. The LTC490 (IC3) is a differential line transceiver originally intended for use in RS485 applications. Using R2, R3 and R4 the driver part used here to get from coaxial to optical is biased to the centre of the permissible common-mode voltage (between -7 V and +12 V for this IC). Moreover, a small offset is added (approx.

0.2 V) to ensure a low level is defined in the absence of an S/PDIF signal.

The input signal is supplied by Tr1, a small transformer you need to wind yourself on an Epcos core type 64290-L44-X830. The primary consists of six turns of 0.3 to 0.5 mm diameter enamelled copper wire (SWG30 - SWG26). The secondary side is made by winding 12 turns of the same wire. Incidentally, C3 prevents the transformer secondary from short-circuiting R3. The capacitor has a negligible effect on the /PDIF signal.

That concludes the more complex part of the circuit, the receiver section of IC3 being followed by a dead standard application circuit around the TOTX173, an optical S/PDIF driver.

The other part of the circuit, i.e., the converter from optical to coaxial, is even simpler. Optical receiver IC2 works happily with the addition of just one capacitor that decouples the supply voltage. The output signal is applied directly to the driver section inside IC3. At the output of that IC, we find another DIY transformer and a coupling capacitor to prevent short-circuiting. Resistor R5 serves

to adapt the output level to the S/PDIF standard.

Transformer Tr2 is wound on the same type of core and using the same wire as Tr1, but this time with 20 turns at the primary and 8 turns at the secondary.

The home made transformers are, of course, not necessary if you do not require electrical isolation between the input and output signals. In that case, you may replace Tr1 with a 100-Ω resistor between ground and the signal line (directly at the input, i.e., ahead of C3). The same applies to Tr2 — this transformer, too, may be replaced by a 100-Ω resistor to ground. It, too, is connected directly to the input, so in this case ahead of R5. Note however that R5 then takes a value of 330 Ω instead of 470 Ω.

We would like to add that this circuit may also prove useful in a computer environment, some sound cards having an on-board S/PDIF output that supplies a signal at TTL level. Such a TTL signal may be applied to the D input of IC3. Components IC2 and C2 are then omitted to add a coaxial S/PDIF output to your trusty PC. Alternatively, the sound card output signal may be applied directly to pin 4 of the TOTX173.

If you do so, do not forget to connect the 8.2-k resistor and the 100-nF capacitor (R1 and C1 in the diagram).

The reverse applies as well — you can also use the circuit to apply an S/PDIF signal to the sound card (that is, if it has a TTL compatible input). In that case, components IC1, R1 and C1 or C4, R5 and Tr2 are omitted (for the coaxial and optical input, respectively).

The supply section consists of a 7805 voltage regulator in its standard configuration. Diode D1 not only serves as a reverse polarity protection device if a DC-output battery eliminator is used, but also allows the circuit to be powered from an 8-15 VAC source. If you use (parts of) the circuit in combination with your PC, the 5-V supply voltage may, of course, be 'stolen' from the PC's power supply. This makes the circuit around IC4 unnecessary, except of course the IC decoupling capacitors C1, C2 and C5.

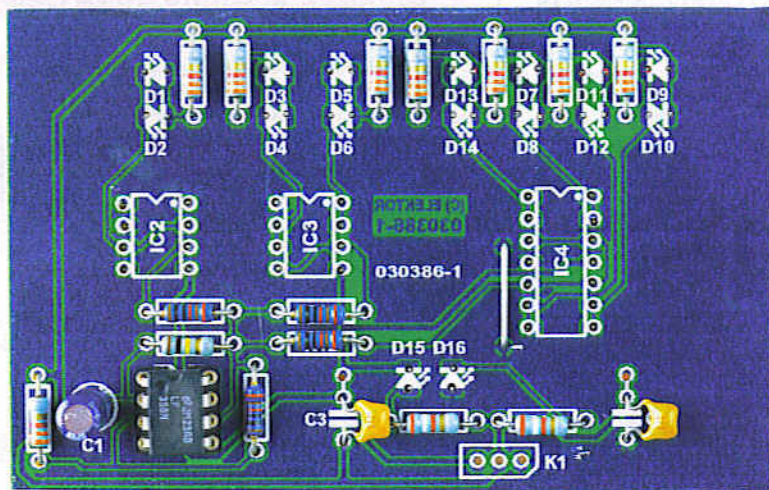
(040317-1)

# OPAMP TESTER

kitchen table

## Quick go/no-go testing for operational amplifiers

Dirk Schumacher



Not a microcontroller in sight, and yet this item of test equipment will be found very handy in any electronics lab.

If you ever want to use an operational amplifier salvaged from an old circuit or from the junk box, you will take into account that the device may no longer work properly. Unfortunately, it is not as easy to perform a quick go/no-go test on an operational amplifier using a multimeter as it is with a resistor, coil, fuse, diode or even a capacitor. Although an opamp tester would obviously be a useful thing to have, a dedicated instrument is not easy to come by. However, you can build this item of test gear yourself in a few minutes, and it certainly won't break the bank.

The test circuit just consists of a simple squarewave oscillator (IC1) which oscillates with a frequency of about 1 Hz. The output of the oscillator, on pin 6, therefore swings between 'high',  $+(V_b - 0.5 \text{ V})$ , and 'low',  $-(V_b - 0.5 \text{ V})$ , with a period of about 1 s.

Most operational amplifiers come in packages containing one, two or four identical circuits. All the manufactur-

ers have standardised on three pinouts, irrespective of the part number of the device. (There are some devices with non-standard pinouts, but they are very rare.) These are shown in the circuit diagram as 'type 1', 'type 2' and 'type 3'. The part numbers of a few 'general purpose' opamps are also shown. Single and dual opamps come in eight-pin packages, quad opamps in 14-pin packages. All the opamps under test are identically wired, as voltage followers/impedance converters. The output voltage is equal to the voltage at the non-inverting input, and so the squarewave from IC1 will therefore be present on all the relevant pins.

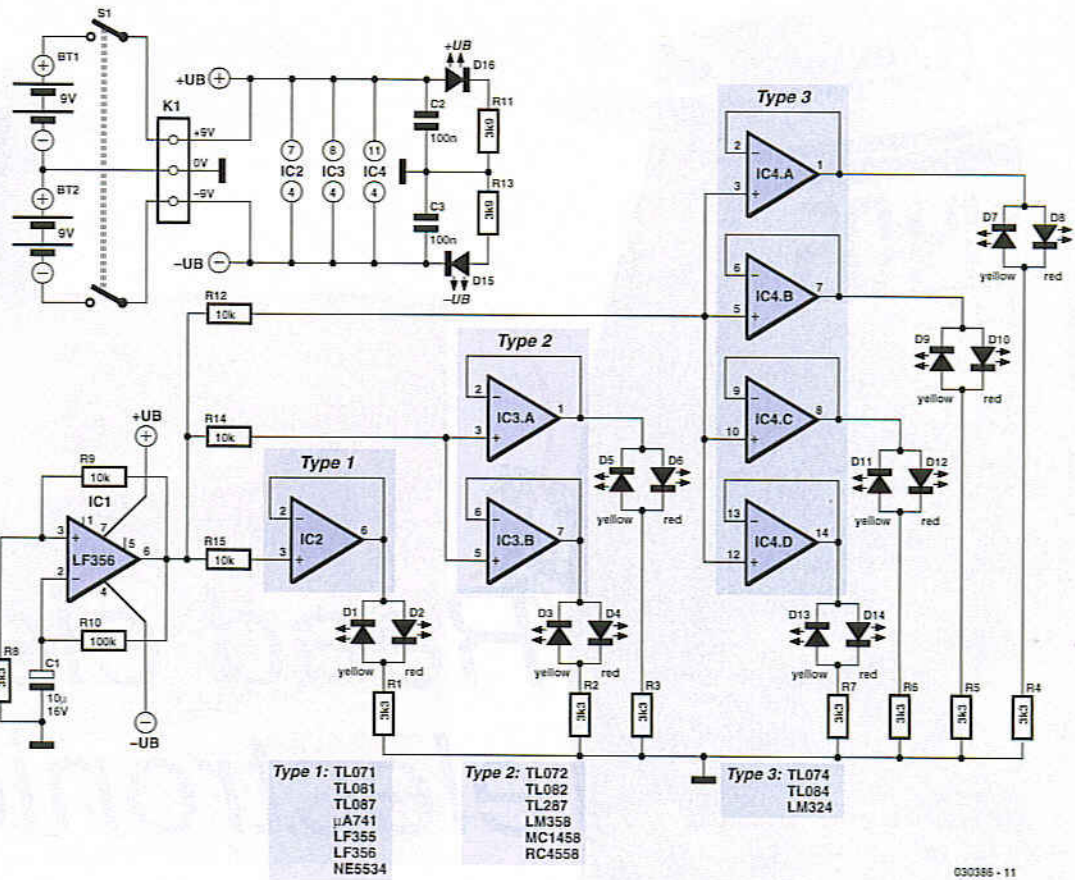
The results of the test are displayed using low current LEDs. If the output of the opamp is high, the red LED will light; if the output is low, the yellow LED will light. The opamps under test will need to be able to sink and source a current of at least 2 mA.

The test unit is powered from two 9 V PP3 (6F22) type batteries (BT1 and

BT2). D15 and D16 indicate when the supply voltage is present on all the relevant pins of the oscillator and of all the test sockets.

As a glance at the printed circuit board layout in **Figure 2** will reveal, populating the board should present no difficulties. There are many LEDs, which must all, of course, be fitted the right way around; the same goes for the small electrolytic capacitor and the oscillator IC. Don't forget the one wire link, which connects the two parts of the ground plane. It is worth clearly marking the position of pin 1 of the test sockets on the front panel of the enclosure, to ensure that devices under test are never inadvertently inserted incorrectly. Otherwise the opamp being tested will quickly give up the ghost, as you will be able to demonstrate when you subsequently insert it correctly!

(030386-1)



030386-11

Figure 1. The circuit can test single, dual and quad opamps.

## COMPONENTS LIST

### Resistors:

R1-R8 = 3k $\Omega$   
 R9,R12,R14,R15 = 10k $\Omega$   
 R10 = 100k $\Omega$   
 R11,R13 = 3k $\Omega$

### Capacitors:

C1 = 10 $\mu$ F 16V radial  
 C2,C3 = 100nF

### Semiconductors:

D1,D3,D5,D7,D9,D11,D13,D15,D16 = LED, 3mm, yellow, low current  
 D2,D4,D6,D8,D10,D12,D14 = LED, 3mm, red, low current  
 IC1 = LF356

### Miscellaneous:

2 8-way IC socket  
 1 14-way IC socket  
 S1 = double-pole on/off switch  
 BT1,BT2 = 9-V battery with clip-on connector  
 Enclosure, Hammond type 1591B  
 1 wire link  
 PCB, order code **030386-1**, see Readers Services page

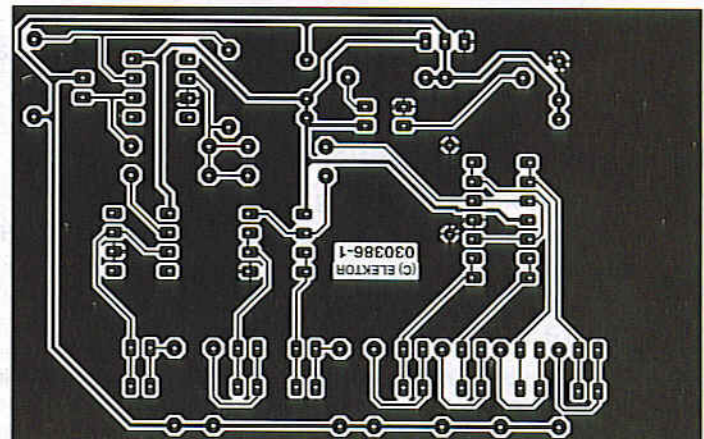
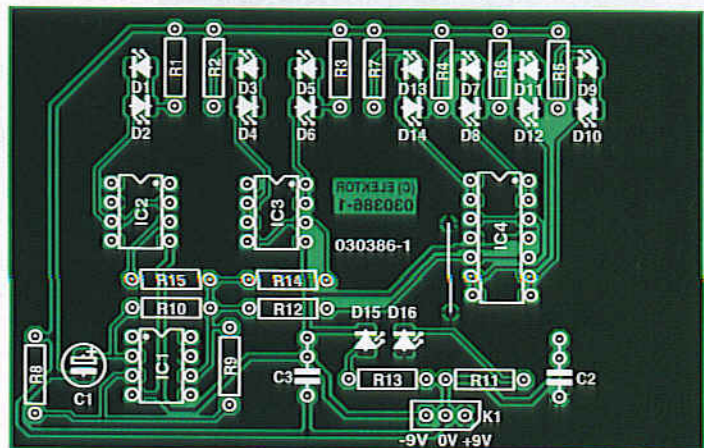


Figure 2. The printed circuit board is clearly laid out.



# Read *elektor electronics* leading the way

Time, Date, Weather Forecast, Humidity, In/Out Temperature and Moon Phase on one display.

**PICK YOUR OWN ANNUAL SUBSCRIPTION and receive this wireless 433 MHz weather station\*!**

Make your choice:

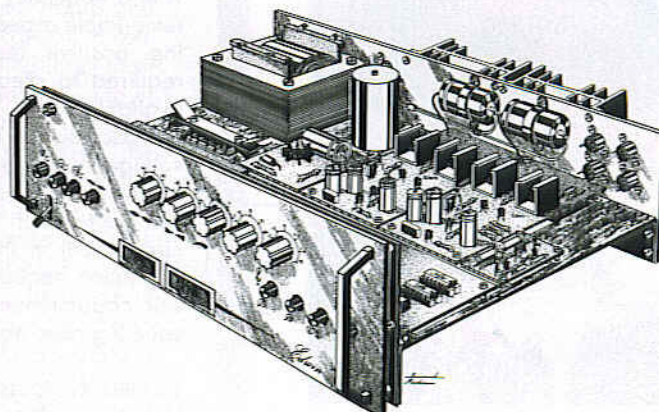
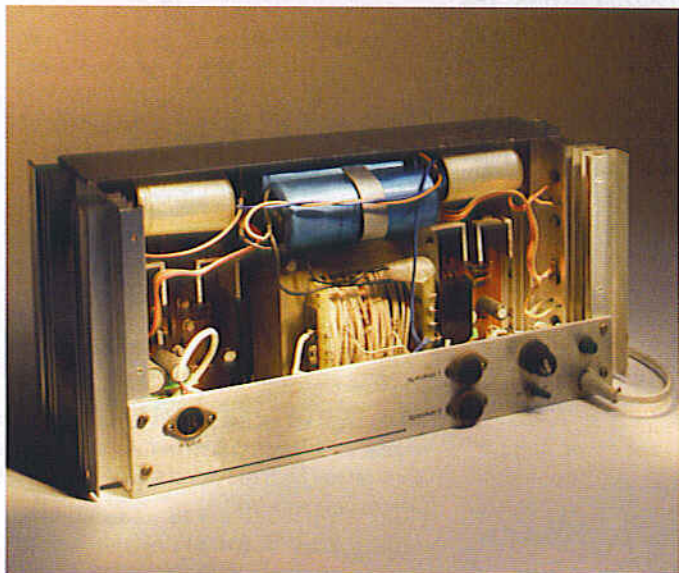
- **Elektor Electronics annual subscription (standard)**  
You receive 11 issues, including the July/August double issue.
- **Elektor Electronics annual subscription-PLUS**  
You receive 11 issues, including the July/August double issue, plus a copy of the Elektor Electronics Volume 2005 CD-ROM (normal price £16.25). Your saving: approx. £10.00!

Please fill out the Order Form with this issue.

Subscription rates and conditions may be found at the back of this issue.

\* Offer available to Subscribers who have not held a Subscription to Elektor Electronics in the last 12 Months. Offer Subject to Availability.





## 'Edwin' Audio Amplifier (1975)

Jan Buiting

Blending in beautifully with this month's focus on all things Audio I'd like to take you back to September 1975 when *Elektor* magazine published an audio amplifier named 'Edwin'. 1975 was the first full year the English-language version of *Elektor* was published. Not surprisingly, the then editors looked at designs that had already proved extremely popular in the German and Dutch editions of the magazine, which had been on the market for some years already. 'Edwin' was a beefed-up version of an even older design which I have been unable to dig out of the archives. Compared to the earlier design, Edwin doubled the output power from just 20 to a mighty 40 watts (maximum).

The huge success of the Edwin publication can be gauged from the resultant PCB sales which, according to some of my older colleagues, achieved many

thousands — something we can only dream of in this day and age of DIY audio electronics having taken a very distant back seat to microcontrollers and PC ancillaries.

The September 1975 'EPS' (Elektor Print Service) column lists the 'Edwin' here as item no. '97-536' at a price of £1.20 including 25% VAT, excluding 15p P&P. If that strikes you as odd, you need to know that in 1975 a copy of the magazine would set you back a whole 35p, and a 2N3055, 70p.

The design of the Edwin would make modern audio amplifier designers either shudder or burst out laughing. The Edwin power output stage comprised 'workhorse' transistors like the BD138, BD130 and 2N3055, while a 2500-microfarads output capacitor was used. The amplifier had common-or-garden small-signal transistors like the famous BC107/BC108 in the prestages and worked from a single-rail 42-VDC supply. Two no-load supply voltages were stated. One was 42.5 VDC for 20 watts into 8 ohms, or 34 watts into 4 ohms.

The other was 46.5 VDC for 24 watts into 8 ohms, or 42 watts into 4 ohms. These values were given to help readers in the choice of the mains transformer's secondary voltage — 30 V<sub>rms</sub> or 33 V<sub>rms</sub>.

The amplifier was claimed to be "unusual in that it embodies two types of output stage in one amplifier". The nitty-gritty was shifting biasing levels of two transistors in the design — depending on the signal level applied, your Edwin would behave as a class-A or a class-B(-ish) amplifier, allegedly without running into too much crossover distortion. The design was advertised as "unconditionally stable" and "short-circuit proof", which was certainly revolutionary at the time.

In 1975, no photographs were printed with any of the published designs, probably owing to cost or the poor paper quality. Instead, enticing 'artist's impressions' were drawn by our former colleague Laurent Martin and printed, in the case of the Edwin, across a full page. The above photograph shows a stereo version of the Edwin I found in our

lab's relics cabinet. It was built with, in my view, complete disregard for electrical safety — note the way the transformer winding was adapted, probably to tweak the secondary voltage.

I was not a little amused by the editors first calling Edwin a "high-quality 40W audio design" in the introduction and then concluding the same article with "Whilst the Edwin amplifier meets an exacting specification this is no reason to recommend its construction by the Hi-Fi enthusiast", which strikes me as much more realistic and modest at the same time. No matter, thousands of readers enjoyed building and using this legendary amplifier!

(045106-1)

Retronics is a monthly column covering vintage electronics including legendary *Elektor* designs. Contributions, suggestions and requests are welcomed; please send an email to [editor@elektor-electronics.co.uk](mailto:editor@elektor-electronics.co.uk), subject: Retronics EE.

# QUIZZ'AWAY



Martin Ohsmann is a Professor of Electrical Engineering and Information Technology at FH Aachen and a long-time contributor to Elektor Electronics. Through Quizz'away he aims at stimulating thought, speculation, construction and simulation as well as raise interesting questions.

## Oddball Oscillator

This time we present yet another problem covering elementary circuit design. The schematic in **Figure 1** shows an opamp circuit supplying a rectangular voltage with a frequency of about 34 kHz. As a remarkable aspect, components establishing positive feedback and normally required to create oscillation, are not available.

The oscillogram in **Figure 2** shows the voltages measured on the coil (U1, upper trace) and at the output (U2, lower trace). The photograph in **Figure 3** shows the circuit built in flying wire fashion. The oscillation frequency is so low that parasitic capacitances, inductances or stray coupling have no effect.

This month's question to you all:  
**How does it work?**

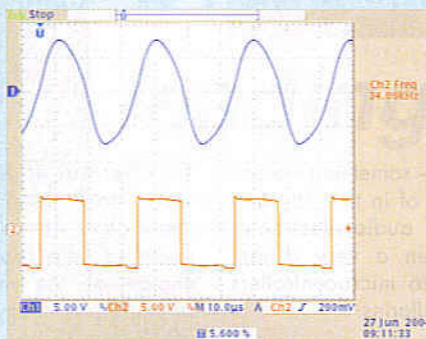


Figure 2. Oscillograms produced by the circuit.

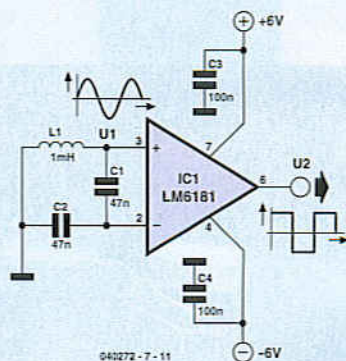


Figure 1. An oddball oscillator.

*Tip: the circuit will not function with any old operational amplifier, but only with a 'certain kind', so it may be a good idea to get your hands on a copy of the LM6181 datasheets (National Semiconductor).*

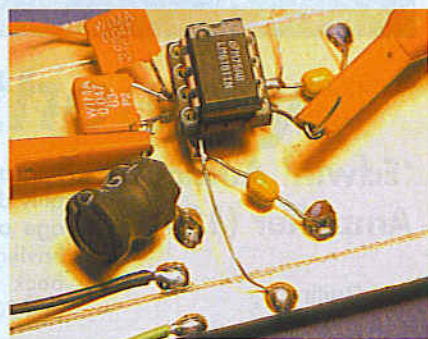


Figure 3. The oscillator in flying-lead construction.

## Quizz'away and win!

Send in the best answer to this month's Quizz'away question and win a ready-built and tested

**Elektor Gameboy Digital Oscilloscope (GBDSO) extension board with PC software, worth £103.**

All answers are processed by Martin Ohsmann in co-operation with Elektor editorial staff. Results are not open to discussion or correspondence and a lucky winner is drawn in case of several correct answers.



Please send your answer to this month's Quizz'away problem, by email, fax or letter to:

**Quizz'away, Elektor Electronics,  
PO Box 190,  
Tunbridge Wells TN5 7WY, England.  
Fax (+44) (0)1580 200616.  
Email: editor@elektor-electronics.co.uk,  
subject: 'quizzaway 3-05'.**

**The closing date is  
25 March 2005**

(solution published in May 2005 issue).  
The outcome of the quiz is final.  
The quiz is not open to employees of  
Segment b.v., its business partners and/or  
associated publishing houses.

As of the September 2004 issue Quizz'away is a regular feature in *Elektor Electronics*. The problems to solve are supplied by Professor Martin Ohsmann of Aachen Technical University.

## Solution to the January 2005 problem

(p. 78; Measurements using a probe — never a problem! For sure?)

For the second time since starting this series, surprisingly few answers were received, although the majority of quiz participants did manage to solve the problem!

The circuit consists of two parts. The first opamp is configured as a classic Schmitt trigger oscillator causing a nearly triangular-shaped voltage on the capacitor.

So far, nothing unusual. However, the configuration of the second opamp, shown here in **Figure 4** should strike you as rather less conventional. With the non-inverting input held at half the opamp's supply voltage, it is effectively connected to 'ground'. The T-junction formed by the 1-megohm resistor and the 1-microfarad capacitor is only effective at very low frequencies. In fact, it only ensures the DC biasing of the opamp remains undisturbed if the oscilloscope input is set to 'AC'.

For the 150-Hz triangular signal, then, the circuit may be further simplified to that shown in **Figure 5**, which now includes the oscilloscope (input) and the probe. The bottom line, then, is that the internal resistance of the probe or the oscilloscope input now determines the opamp's feedback path!

The opamp will attempt to adjust its output voltage in such a way that the differ-

ential voltage between its inputs becomes zero. Since negligible currents flow into the opamp inputs, the current that maintains a constant potential of  $U/2$  at the inverting input must be supplied by the opamp's output, and, therefore, flow through the feedback impedance. Consequently, the feedback path carries a triangular-shaped current whose excursion (level) is independent of the feedback impedance value. Seen from the oscilloscope, the circuit presents a constant-current source! At a constant current, the 9-megohm series resistor in the probe is largely irrelevant, while the current through the scope's 1-megohm input resistance is independent of the probe setting.

The above effect only occurs within the drive margins of the opamp. Also, the opamp circuit has to be supplied from a battery to allow the oscilloscope to be connected up in 'floating' fashion as indicated. It is also not allowed to connect the 'scope the other way around because junction 'A' in the circuit is extremely likely to react to hum and other noise.

As the decisive factor, the circuit demonstrates that a probe will only 'divide' properly if the internal resistance of the signal source is small relative to the probe impedance.

**Moral of the story:**  
You will realise, of course...  
the resistance of the source!

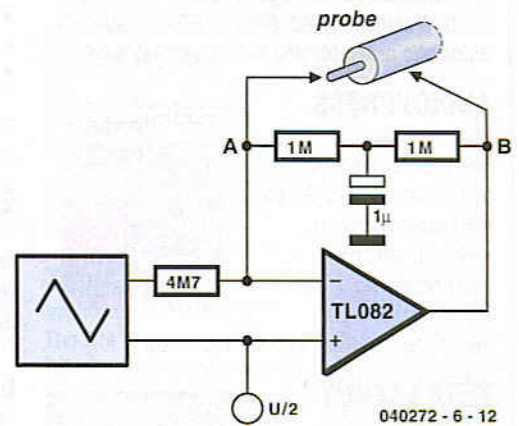


Figure 4. Simplified circuit of the 'probe mix up'.

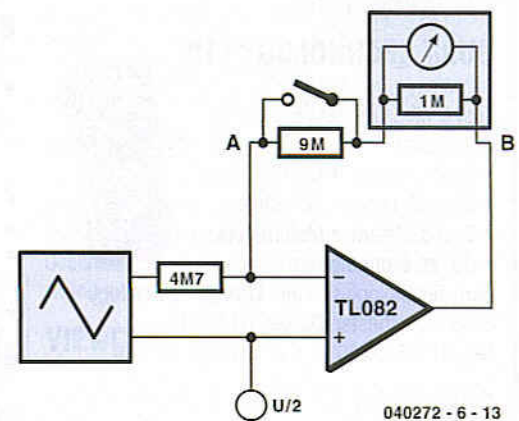


Figure 5. The bare essentials.

Advertisement

[www.ThePCBSHOP.com](http://www.ThePCBSHOP.com)

Prototypes and small series up to 1000 pcs

Value for Money

Up to 6 layer boards

Always Available

Attractive price

On-line Printed Circuit Boards

Double Sided, 1.6 mm,  
Plated Through,  
Green Solder mask,  
Hot Air Level,  
1 White Legend.  
Price including  
tooling + plotting + VAT

100 mm x 160 mm  
1 pc = 45.74 Euro

100 mm x 80 mm  
5 pcs = 68.97 Euro

To book your website space contact Huson International Media

Tel. 0044 (0) 1932 564999 Fax 0044 (0) 1932 564998

## ALLGOOD TECHNOLOGY

[www.allgoodtechnology.com](http://www.allgoodtechnology.com)

Low-medium volume sub-contract assembly. SMT specialist since 1990. Customers include military, aerospace etc. 0402 to BGA capabilities, automatic assembly and hand built prototypes.

## AUDIOXPRESS

[www.audioXpress.com](http://www.audioXpress.com)

The premier do-it-yourself audio magazine for 35 years.

- Hands-on projects
- Helpful articles
- Expert advice
- New technologies

Full range of books, back issues on CD



## BETA LAYOUT

[www.pcb-pool.com](http://www.pcb-pool.com)

Beta layout Ltd Award-winning site in both English and German offers prototype

PCBs at a fraction of the cost of the usual manufacturers' prices.



## BURN TECHNOLOGY LTD

<http://www.burntec.com>

Test & Measurement Equipment Distributors

- Anemometers • Clamp Meters
- Light Meters • LCR Meters
- Sound Meters • Multimeters
- Device Programmers

Burn Technology Limited, Winfrith Technology Centre, Dorchester, Dorset, DT2 8DH

Tel: (01305) 852090 Fax: (01305) 851940



## COMPUCUT

<http://www.compucutters.com>

Computer Numerical Control from your home PC. Great for tricky jobs, and accurate repetitive work. We supply: - Software - Interface - Manual - Support

Price £250 plus postage.

## CONFORD ELECTRONICS

<http://www.confordelec.co.uk>

Lightweight portable battery/mains audio units offering the highest technical performance. Microphone, Phantom Power and Headphone Amplifiers. Balanced/unbalanced signal lines with extensive RFI protection.

## DANBURY ELECTRONICS

<http://www.livinginthepast.demon.co.uk>

Here you will find our mains and output transformers in Mike Holme's range of valve/tube amplifiers (PP & SE). Also circuits, parts lists, chassis, advice.

## DEBUG INNOVATIONS UK

<http://www.debuginnovations.com>

Introducing hassle free prototyping

- RF / Analogue
- Surface mount
- Power planes
- Unique patch architecture
- High speed digital
- 0.1" grid

Forget custom PCBs, start your project now!



## EASYSYNC

<http://www.easysync.co.uk>

EasySync Ltd sells a wide range of single and multi-port USB to RS232/RS422 and RS485 converters at competitive prices.



## ELEXOL PTY LTD

<http://www.elexol.com>

Developer and manufacturer of

- USB Development Modules.
- USBMOD Series.
- USBIO24 Digital Input/Output Module.
- MP3 Solutions. • MP3MOD4 Module.

Distributor inquiries welcome.



## ELNEC

[www.elnec.com](http://www.elnec.com)

- device programmer manufacturer
- selling through contracted distributors all over the world
- universal and dedicated device programmers
- excellent support and after sale support
- free SW updates • reliable HW
- once a months new SW release
- three years warranty for most programmers



## ERVAN INTERNATIONAL CO.

<http://www.ervan-int.com>

Power Electronics and Solar Energy Design and Consultants. Also offers;

- Discount prices of:
- Ultra Bright LEDs • PCB LED Cluster Kits
  - Laser Pointers • Solar Modules
  - Batteries

Compiler, Prog 'n Drop Visual Development and a well featured debugging environment.

## FOREST ELECTRONIC DEVELOPMENT

<http://www.fored.co.uk>

FED supply PIC programmers, Basic modules, and development software including a PIC C

## FUTURLEC

<http://www.futurlec.com>

Save up to 60% on

- Electronic Components
- Microcontrollers, PIC, Atmel
- Development Boards, Programmers

Huge range of products available on-line for immediate delivery, at very competitive prices.

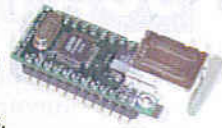


## FUTURE TECHNOLOGY DEVICES

<http://www.ftdichip.com>

FTDI designs and sells USB-UART and USB-FIFO interface i.c.'s.

Complete with PC drivers, these devices simplify the task of designing or upgrading peripherals to USB



## HAMMOND ELECTRONICS

<http://www.hammondmfg.com>,

[sales@hammond-electronics.co.uk](mailto:sales@hammond-electronics.co.uk)

tel: 01256 812812.

Small die-cast, plastic and metal enclosures for the hobbyist and professional. Widely available from major distributors.



## ILP ELECTRONICS LIMITED

<http://www.ilpelectronics.com>

ILP has been in the audio industry for over 30 years primarily manufacturing both standard and custom audio modules and pre-amplifiers.



## IPEVA LIMITED

<http://www.ipeva.com>

IPEVA sell low cost USB FPGA development boards. IPEVA provide Design Consultancy for Embedded Systems, OpenCores-IP, FPGA, ASIC, HDL translation and migration. Tel. 0870 080 2340



## JLB ELECTRONICS

[www.jlbelectronics.com](http://www.jlbelectronics.com)

Suppliers of electrical / electronic parts and consumables. Including:

- Cable ties / bases
- Bootlace ferrules
- Solvent sprays & cleaners
- Heat sink compound
- Tools / hardware
- Connectors
- PVC Tape

## KOMCARD

<http://www.komcard.com>

Learn how to design a PCI card, and write a PCI device driver. We lead you step by step with practical PCI projects you build.

## LONDON ELECTRONICS COLLEGE

<http://www.lec.org.uk>

Vocational training and education for national qualifications in Electronics Engineering and Information Technology (BTEC First National, Higher National NVQs, GCSEs and Advanced Qualifications). Also Technical Management and Languages.

## MQP ELECTRONICS

<http://www.mqpelectronics.co.uk>

Leaders in Device Programming Solutions.

- Online shop
- Low Cost Adapters for all Programmers
- Single Site and Gang Programmers
- Support for virtually any Programmable Device



## NEW WAVE CONCEPTS

<http://www.new-wave-concepts.com>

Software for hobbyists:

- Livewire circuit simulation software, only £29.36
- PCB Wizard circuit design software, only £29.36



Available from all Maplin

Electronics stores and [www.maplin.co.uk](http://www.maplin.co.uk)

## PCB WORLD

<http://www.pcbworld.org.uk>

World-class site: Your magazine project or prototype PCB from the artwork of your choice for less. Call Lee on 07946 846159 for details. Prompt service.

## PEAK ELECTRONIC DESIGN LIMITED

[www.peakelec.co.uk](http://www.peakelec.co.uk)

Cool component test gear for your passives and semis.

Instant identification, measurement and validation. Connect anyway round.

The Peak Atlas family starts from £59.



## PHYZX

<http://www.phyzx.co.uk>

Automatically Plot and Drill PCB's

- Accurately
- Repeatably
- Mains operated
- Robust Steel Construction
- Gerber RS274X compatible
- Full XYZ RS232 Control
- Including Accessories
- Complete system Under £500

## PICDOS™

<http://www.picdos.com>

Hard disk, DOS & files on PIC16F877.

SmartMedia™ based.

No complex hardware just wires.

Run-Debug existing PIC code & interrupts.

Free schematics, software, debugger



## QUASAR ELECTRONICS

[www.QuasarElectronics.com](http://www.QuasarElectronics.com)

Over 300 electronic kits, projects and ready built units for hobby, education

and industrial applications

including PIC/ATMEL

programming solutions. Online ordering facilities.

Tel: +44 (0) 870 246 1826

Fax: +44 (0) 870 460 1045

Email: [sales@QuasarElectronics.com](mailto:sales@QuasarElectronics.com)



## ROBOT ELECTRONICS

<http://www.robot-electronics.co.uk>

- Ultrasonic rangefinders
- Motor H-Bridge controllers
- Magnetic Compasses
- RC servos and controllers
- PIC programmers and components
- Electronic Design/Development and Manufacturer to industry



## TECHNOBOTS

<http://www.technobots.co.uk>

Welcome to Technobots - the one stop shop specially for the remote operated robot builder, radio control and engineering hobbyist.



## TELNET

<http://www.telnet.uk.com>

The site shows graphically Telnets wide range of quality second-user test and measurement equipment, including oscilloscopes and spectrum analysers.



## ULTRALEDS

<http://www.ultraleds.co.uk>

tel: 0871 7110413

Large range of low cost Ultra bright leds and Led related lighting products. Major credit cards taken online with same day despatch.



## USB INSTRUMENTS

<http://www.usb-instruments.com>

USB Instruments specialises in PC based instrumentation products and software packages. Oscilloscopes, Data Loggers, Logic Analysers which interface to your PC via USB.

## VIEWCOM

<http://www.viewcom.f9.co.uk>

tel: 020 8471 9338 fax: 020 8552 0946

- Mail Order supplier of:
- Integrated Circuits and Components.
- Kit and parts for Elektor projects.
- Transistors, FETs, Capacitors, Resistors, Crystals, etc and hard to find devices.

Viewcom Electronics, 77 Upperton Road West, Plaistow, London E13 9LT

## VIRTINS TECHNOLOGY

<http://www.virtins.com>

PC based virtual instrument for electronics enthusiasts, students and professionals, including full-fledged sound card real time Oscilloscope, Spectrum, Analyzer and Signal, Generator, Downloader and try.



## ELECTRONIC ENTHUSIASTS

Only one magazine tests its projects and circuits in its own lab before publication

**ELEKTOR ELECTRONICS THE ELECTRONICS & COMPUTER MAGAZINE**

**SUBSCRIBE TODAY!**

Contact: Worldwide Subscription Service Ltd, Unit 4 Gibbs Reed Farm, Pashley Road, Titchhurst TN15 7HE Tel: 01580 200657 Fax: 01580 200616 [www.elektor-electronics.co.uk](http://www.elektor-electronics.co.uk)

## PROMOTE YOUR WEBSITE HERE

Elektor Electronics have a feature to help customers to promote their websites, Net Links - a permanent feature of the magazine where you will be able to highlight your site on a regular basis.

- For just £120 + VAT (£10.90 per issue for eleven issues) Elektor will publish your company name, a 25-word description and your website address.

- For £300 + VAT for the year (£27.27 per issue for eleven issues) we will publish the above plus run a 3cm deep full colour screen shot from your site.

Places are limited and spaces will go on a strictly first come, first served basis, please fax back your order today!

I wish to promote my company, please book my space:

- Text insertion only for £120 + VAT
- Text and photo for £300 + VAT

NAME: ..... ORGANISATION: .....

JOB TITLE: .....

ADDRESS: .....

..... TEL: .....

PLEASE COMPLETE COUPON BELOW AND FAX BACK TO 00-44-(0)1932 564998

COMPANY NAME .....

WEB ADDRESS .....

25-WORD DESCRIPTION .....

.....

.....

**Please Note**

Diskettes are supplied for the convenience of readers without internet access.

|   | £      | US \$  |
|---|--------|--------|
| <b>READY-BUILT PROJECTS</b>   |        |        |
| <b>ClariTy 300-W Class-T Amplifier</b>  |        |        |
| 030217-91 Amplifier board with SMDs pre-fitted; cores for L1 & L2               | 34.50  | 55.70  |
| <b>Flash Microcontroller Starter Kit</b>  |        |        |
| 010208-91 ready-assembled PCB incl. software, cable, adapter & related articles | 69.00  | 112.50 |
| <b>Gameboy Digital Sampling Oscilloscope (GBDSO)</b>                            |        |        |
| 990082-91 ready-assembled board, incl. the PC software and related articles     | 103.00 | 183.00 |
| <b>Micro Webserver with MSC1210 Board</b>                                       |        |        |
| 030060-91 Microprocessor Board, ready-assembled                                 | 69.00  | 112.50 |
| 044026-91 Network Extension Board, ready-assembled                              | 41.95  | 73.95  |
| 044026-92 Combined package (030060-91 & 044026-91 & related articles)           | 103.50 | 184.95 |
| <b>EVERGREENS</b>   |        |        |
| <b>Elektor Electronics Help Disk</b>  |        |        |
| 960022-1 Disk, Windows version  | 8.15   | 14.45  |
| <b>Elektor Electronics Item Tracer 1985-2003</b>                                |        |        |
| 046003-11 contents database (disk, Windows version)                             | 8.15   | 14.35  |
| <b>Universal Prototyping Boards</b>   |        |        |
| UPBS-1 PCB  | 2.45   | 4.30   |
| UPBS-2 2 PCBs   | 4.10   | 7.25   |
| UPBS-4 4 PCBs   | 6.55   | 11.55  |
| <b>No. 341 MARCH 2005</b>   |        |        |
| <b>High-End Power Amp</b>   |        |        |
| 040198-1 Amplifier PCB  | 8.10   | 15.30  |
| 040198-2 Indicator PCB  | 6.70   | 12.60  |
| 040198-3 Supply PCB   | 6.70   | 12.60  |
| 040198-4 Fuse PCB   | 3.75   | 7.10   |
| <b>Opamp Tester</b>   |        |        |
| 030386-1 PCB  | 5.55   | 10.45  |
| <b>Play Solitaire</b>   |        |        |
| 030410-11 Disk, project software  | 5.20   | 9.75   |
| 030410-41 AT90S2313-10PC, programmed  | 4.60   | 8.65   |
| <b>Remote Temperature Logger for PIC18F Board</b>                               |        |        |
| 040441-11 Disk, project software  | 5.20   | 9.75   |
| <b>Serially Programmable Crystal Oscillator</b>                                 |        |        |
| 040351-11 Disk, project software  | 5.20   | 9.75   |
| <b>No. 340 FEBRUARY 2005</b>  |        |        |
| <b>RFID Detector for 13.56 MHz</b>  |        |        |
| 040299-1 PCB  | 9.65   | 18.65  |
| <b>Walking Bug</b>  |        |        |
| 040071-11 Disk, source & hex code files   | 5.70   | 10.80  |
| 040071-41 AT90S2313-10PI, programmed  | 8.65   | 16.40  |
| <b>No. 339 JANUARY 2005</b>   |        |        |
| <b>ATX Power Supply Tester</b>  |        |        |
| 040112-1 PCB  | 11.85  | 21.00  |
| <b>Intelligent Clap Switch</b>  |        |        |
| 030166-1 PCB  | 8.30   | 14.70  |
| 030166-11 Disk, source & hex files  | 4.90   | 8.65   |
| 030166-41 PIC12F629CP, programmed   | 6.90   | 12.20  |
| <b>PIC18F Development Board</b>   |        |        |
| 040010-1 PCB  | 10.90  | 19.30  |
| 040010-11 Disk, software utilities  | 4.90   | 8.65   |
| <b>No. 338 DECEMBER 2004</b>  |        |        |
| <b>I_C Home Bus</b>   |        |        |
| 040333-1 PCB  | 12.10  | 21.40  |
| 040333-11 Disk, source & hex code files   | 4.90   | 8.65   |
| <b>LED Christmas Tree</b>   |        |        |
| 010019-91 Kit of PCB & parts  | 6.25   | 11.00  |
| <b>USB / I_C Interface</b>  |        |        |
| 040334-1 PCB  | 7.65   | 13.50  |
| 040334-11 Disk, project software  | 4.90   | 8.65   |
| 040334-21 24LC64, programmed  | 4.60   | 8.50   |
| <b>No. 337 NOVEMBER 2004</b>  |        |        |
| <b>Noise Suppression Filters</b>  |        |        |
| 030217-3 PCB  | 13.35  | 23.65  |
| <b>Vehicle Battery Jogger</b>   |        |        |
| 044021-1 PCB  | 6.75   | 11.95  |
| <b>No. 336 OCTOBER 2004</b>   |        |        |
| <b>ClariTy 300-W Class-T Amplifier</b>  |        |        |
| 030217-2 PCB  | 15.90  | 28.10  |
| <b>Four in a Row</b>  |        |        |
| 030146-1 PCB  | 13.15  | 23.25  |

**GENERAL**

Printed-circuit boards (PCBs), self-adhesive front panel foils, ROMs, EPROMs, PALs, GALs, microcontrollers and diskettes for projects which have appeared in *Elektor Electronics* may be ordered using the Order Form printed opposite. The form may also be used to order books (private customers only).

» The artwork for making a PCB which is not available ready-made through the Readers Services may be found in the relevant article.

» EPROMs, GALs, PALs, (E)PLDs, MACHs, PICs and other microcontrollers are supplied ready-programmed.

Prices and item descriptions subject to change. The publishers reserve the right to change prices without prior notification. Prices and item descriptions shown here supersede those in previous issues. E. & G.E.

**PAST ISSUES**

Past issues, if available, should be ordered from **Worldwide Subscription Service Ltd, Unit 4, Gibbs Reed Farm, Pashley Road, TICEHURST TN5 7HE, England, telephone (+44) 1580 200657, fax (+44) 1580 200616, email wss@wss.demon.co.uk**

Prices of past issues (except July/August and December), including postage for single copies, are £4.75 (UK and Eire); £5.30 (air mail Europe); £6.10 (airmail outside Europe). Prices of past July/August and December issues, including postage for single copies, are £6.65 (UK and Eire); £7.35 (airmail Europe); and £8.45 (airmail outside Europe).

**PAST ARTICLES**

For information on past articles, please contact our Editorial and Administrative Offices, telephone (01580) 200657; fax 200616, email sales@elektor-electronics.co.uk.

|  | £     | US \$ |
|--|-------|-------|
| 030146-11 Disk, source & hex code                        | 4.90  | 8.65  |
| 030146-41 AT90S2313-10PC, programmed                     | 7.40  | 13.10 |
| <b>No. 335 SEPTEMBER 2004</b>                            |       |       |
| <b>Rolling Dice</b>                                      |       |       |
| 040248-1 PCB set (6 sides)                               | 13.75 | 24.30 |
| 040248-11 Disk, source & hex files                       | 4.90  | 8.65  |
| 040248-41 AT89C2051-12PI, programmed                     | 8.70  | 15.40 |
| <b>Swiss Army Knife</b>                                  |       |       |
| 030448-1 PCB set: MCU, RS232, USB                        | 9.50  | 16.80 |
| 030448-11 Disk set (a+b), all project software           | 6.50  | 11.50 |
| 030448-41 AT89S8252-24PC, programmed                     | 25.85 | 45.75 |
| <b>No. 334 JULY/AUGUST 2004</b>                          |       |       |
| <b>IR Servo Motor Interface</b>                          |       |       |
| 020356-11 Disk, RCX program and PIC source & object code | 4.90  | 8.65  |
| 020356-41 PIC16F628, programmed                          | 10.00 | 17.70 |
| 020356-42 PIC16F628, programmed                          | 10.00 | 17.70 |
| <b>Micro Webserver with MSC1210 Board</b>                |       |       |
| 044026-1 Network Extension Board, PCB only               | 10.45 | 18.50 |
| <b>R/C Analyser</b>                                      |       |       |
| 030178-11 Disk, PIC source code                          | 4.90  | 8.65  |
| 030178-41 PIC16F627-4/CP, programmed                     | 10.25 | 18.15 |
| <b>USB Converter Controlled via HTML</b>                 |       |       |
| 044034-11 Disk, example programs                         | 4.90  | 8.65  |
| <b>Working with ActiveX</b>                              |       |       |
| 030431-11 Disk   | 4.90  | 8.65  |
| <b>No. 333 JUNE 2004</b>                                 |       |       |
| <b>Multi Programmer</b>                                  |       |       |
| 020336-1 PCB   | 8.80  | 15.60 |
| 020336-11 Disk, firmware & source code                   | 4.90  | 8.65  |
| <b>Pocket Pong</b>                                       |       |       |
| 030320-11 Disk, PIC software                             | 4.90  | 8.65  |
| <b>Rail Router</b>                                       |       |       |
| 030403-1 PCB   | 10.80 | 19.15 |
| 030403-11 Disk, PIC & PC software                        | 4.90  | 8.65  |
| 030403-41 PIC16F877-20/P, programmed                     | 21.45 | 37.95 |
| <b>Smooth Operator</b>                                   |       |       |
| 030209-11 Disk, PIC software                             | 4.90  | 8.65  |
| 030209-41 PIC16F84-10P, programmed                       | 14.70 | 26.00 |
| <b>No. 332 MAY 2004</b>                                  |       |       |
| <b>Design Your Own IC</b>                                |       |       |
| 030385-1 PCB   | 15.65 | 27.70 |
| <b>High-End Preamp</b>                                   |       |       |
| 020046-1 PCB — main board                                | 8.45  | 14.95 |
| 020046-2 PCB — relay board                               | 7.50  | 13.30 |
| 020046-3 PCB — PSU board                                 | 6.70  | 11.85 |
| 020046-11 Disk   | 4.90  | 8.65  |
| 020046-41 PIC18LF452-1/L, programmed                     | 28.20 | 49.90 |
| <b>Wind Speed &amp; Direction Meter</b>                  |       |       |
| 030371-11 Disk, project software                         | 4.90  | 8.65  |
| 030371-41 PIC16F871, programmed                          | 17.55 | 31.05 |
| <b>No. 331 APRIL 2004</b>                                |       |       |
| <b>Drop-in Microcontroller Board</b>                     |       |       |
| 020148-1 PCB   | 8.60  | 15.20 |
| 020148-11 Disk, sample project file                      | 4.90  | 8.65  |
| <b>VHF-Low Explorer</b>                                  |       |       |
| 020416-1 PCB   | 8.80  | 15.50 |
| <b>No. 330 MARCH 2004</b>                                |       |       |
| <b>Build Your Own DRM Receiver</b>                       |       |       |
| 030365-1 PCB   | 9.10  | 16.10 |
| 030365-11 Disk, DRM.exe program                          | 4.90  | 8.65  |
| <b>Code Lock</b>   |       |       |
| 020434-1 PCB   | 9.60  | 16.95 |

|  | £     | US \$ |
|--|-------|-------|
| 020434-11 Disk, source & hex code files                  | 4-90  | 8.65  |
| 020434-41 Pic16F84A-4P, programmed                       | 14-70 | 26.00 |
| <b>Hands-on CPLDs (2)</b>                                |       |       |
| 030052-1 PCB   | 8-90  | 15.75 |
| 030052-11 Software                                       | 4-90  | 8.65  |
| 030052-41 EPM7128SLC84-15, programmed                    | 33-40 | 59.10 |
| <b>Multichannel Failsafe for Radio Controlled Models</b> |       |       |
| 020382-11 Disk, source code file                         | 4-90  | 8.65  |
| 020382-41 AT89C52-24JL, programmed                       | 8-70  | 15.40 |
| <b>Multifunction Frequency Meter</b>                     |       |       |
| 030136-1 PCB   | 9-35  | 16.55 |
| 030136-11 Disk, project software                         | 4-90  | 8.65  |
| 030136-41 AT90S2313-10PC, programmed                     | 7-95  | 14.05 |
| <b>No. 329 FEBRUARY 2004</b>                             |       |       |
| <b>Digital Alarm Clock</b>                               |       |       |
| 030096-11 Disk, PIC source and hex code                  | 4-90  | 8.65  |
| 030096-41 PIC16F84-04/p, programmed                      | 15-20 | 26.90 |
| <b>iAccess</b>   |       |       |
| 020163-11 Disk set, source code and control software     | 7-50  | 13.30 |
| 020163-41 AT89S8252-12PC, programmed                     | 13-90 | 24.60 |
| <b>Simple 12-to-230V Power Inverter</b>                  |       |       |
| 020435-1 PCB   | 8-50  | 15.05 |
| <b>Touch-controlled Switch</b>                           |       |       |
| 030214-11 Disk, PIC source code                          | 4-90  | 8.65  |
| 030214-41 PIC12C508A04/S08, programmed                   | 6-15  | 10.90 |
| <b>No. 328 JANUARY 2004</b>                              |       |       |
| <b>64-K 80C552 Flash Board</b>                           |       |       |
| 030042-1 PCB   | 9-35  | 16.55 |
| 030042-11 Disk, misc. project software                   | 4-90  | 8.65  |
| 030042-21 29F010, programmed                             | 10-00 | 17.70 |
| 030042-31 GAL 16V8D150P, programmed                      | 6-10  | 10.80 |
| <b>Climate Logger</b>                                    |       |       |
| 030076-1 PCB   | 7-75  | 13.70 |
| 030076-11 Disk, Windows software                         | 4-90  | 8.65  |
| <b>FMS Flight Simulator Encoder</b>                      |       |       |
| 030066-1 PCB   | 10-20 | 18.05 |
| 030066-41 87LPC767BN, programmed                         | 17-05 | 30.15 |
| <b>LED Roulette</b>                                      |       |       |
| 030168-1 PCB   | 17-90 | 31.60 |
| 030168-11 Disk, source and hex files                     | 4-90  | 8.65  |
| 030168-41 89C2051-12PC, programmed                       | 8-05  | 14.25 |
| <b>Multi-event Alarm Clock</b>                           |       |       |
| 020304-11 Disk, C (source) hex files                     | 4-90  | 8.65  |
| 020304-41 AT89C2051-12PC, programmed                     | 6-10  | 10.80 |
| <b>Stepper Motors Uncovered</b>                          |       |       |
| 020127-41 PIC16F873-20/SP                                | 19-10 | 33.80 |
| <b>No. 327 DECEMBER 2003</b>                             |       |       |
| <b>FM Remote Control Transmitter &amp; Receiver</b>      |       |       |
| 034044-1 PCB   | 10-20 | 18.05 |
| <b>LED Christmas Decoration</b>                          |       |       |
| 030157-1 PCB   | 7-55  | 13.35 |
| <b>P87LPC76x Programmer</b>                              |       |       |
| 030313-11 Disk, project software                         | 4-90  | 8.65  |
| <b>Project Timekeeper</b>                                |       |       |
| 020350-11 Disk, source & object code files               | 4-90  | 8.65  |
| 020350-41 PIC16F84-10P, programmed                       | 13-15 | 23.25 |
| <b>Stepper Motors Uncovered (2)</b>                      |       |       |
| 020127-11 Disk, source code file                         | 4-90  | 8.65  |
| <b>Universal Clock Generator</b>                         |       |       |
| 020395-11 Disk, source code file                         | 4-90  | 8.65  |
| <b>Wireless RS232 Link</b>                               |       |       |
| 030204-1 PCB   | 8-70  | 15.40 |
| <b>No. 326 NOVEMBER 2003</b>                             |       |       |
| <b>Precision Measurement Central</b>                     |       |       |
| 030060-4 PCB   | 8-70  | 15.40 |
| <b>No. 326 NOVEMBER 2003</b>                             |       |       |
| <b>Rev Counter for R/C Models</b>                        |       |       |
| 024111-1 PCB   | 17-50 | 31.00 |
| 024111-11 Disk, source and hex code                      | 4-90  | 8.65  |
| 024111-41 89C2051-12PC, programmed                       | 8-85  | 15.65 |
| <b>Running Text Display</b>                              |       |       |
| 020407-11 Disk, source and hex code                      | 4-90  | 8.65  |
| <b>USB Analogue Converter</b>                            |       |       |
| 020374-1 PCB   | 7-65  | 13.50 |
| 020374-11 Disk, hex code and Windows software            | 4-90  | 8.65  |
| 020374-41 PIC16C765, programmed                          | 13-25 | 23.45 |
| <b>No. 325 OCTOBER 2003</b>                              |       |       |
| <b>DDS RF Signal Generator</b>                           |       |       |
| 020299-2 PCB, control/supply                             | 12-10 | 21.45 |
| 020299-41 AT90S8515 8PC, programmed                      | 30-55 | 54.05 |
| <b>Minimalist Induction-Balance Metal Detector</b>       |       |       |
| 020290-1 PCB   | 8-95  | 15.85 |

|  | £     | US \$ |
|--|-------|-------|
| <b>Xilinx PROM Programmer</b>                    |       |       |
| 010109-11 Software                               | 4-90  | 8.65  |
| <b>No. 324 SEPTEMBER 2003</b>                    |       |       |
| <b>ATV Picture Generator</b>                     |       |       |
| 020295-11 Disk, source & hex code files          | 4-90  | 8.65  |
| 26.90 020295-41 AT90S8515-8PC, programmed        | 15-20 |       |
| 24.60 020295-42 AT90S1200-12PC, programmed       | 13-90 |       |
| <b>DTMF Remote Telephone Switch</b>              |       |       |
| 020294-1 PCB                                     | 11-65 | 20.60 |
| 020294-11 Disk, project software                 | 4-90  | 8.65  |
| 26.00 020294-41 PIC16F84A-20/P, programmed       | 14-70 |       |
| <b>LC Display with I C Bus</b>                   |       |       |
| 030060-2 PCB                                     | 7-35  | 13.00 |
| <b>PICProg 2003</b>                              |       |       |
| 010202-1 PCB                                     | 9-05  | 16.00 |
| 010202-11 Disk, Windows software                 | 4-90  | 8.65  |
| 010202-41 PIC16F874-20/P, programmed             | 23-55 | 41.65 |
| <b>Polyphonic Doorbell</b>                       |       |       |
| 020354-11 Disk, project software                 | 4-90  | 8.65  |
| 25.55 020354-41 PIC16F84A-10/P, programmed       | 14-45 |       |
| <b>Precision Measurement Central</b>             |       |       |
| 030060-91 Ready-assembled & tested board         | 69-00 |       |
| 112.50   |       |       |
| <b>Valve Pre-amplifier (1)</b>                   |       |       |
| 020383-1 PCB, amplifier board                    | 11-55 | 20.40 |
| 020383-2 PCB, power supply board                 | 11-40 | 20.20 |
| 020383-3 PCB, I/O board                          | 10-10 | 17.80 |
| <b>No. 323 JULY/AUGUST 2003</b>                  |       |       |
| <b>Add a Sparkle</b>                             |       |       |
| 020293-11 Disk, HEX and source files             | 4-90  | 8.65  |
| 020293-41 PIC12C508A-04/SM, programmed           | 7-40  | 13.10 |
| <b>AT90S2313 Programmer</b>                      |       |       |
| 034036-1 PCB                                     | 9-05  | 16.00 |
| <b>Mini Running Text Display</b>                 |       |       |
| 020365-11 Disk, source code file                 | 4-90  | 8.65  |
| <b>Mini Test Chart Generator</b>                 |       |       |
| 020403-11 Disk, PIC source code                  | 4-90  | 8.65  |
| <b>Programming Tool for ATtiny15</b>             |       |       |
| 030030-1 PCB                                     | 7-55  | 13.35 |
| 030030-11 Disk, project software                 | 4-90  | 8.65  |
| <b>Quad Bridge Car Amp</b>                       |       |       |
| 034039-1 PCB                                     | 8-70  | 15.35 |
| <b>Remote Light Control with Dimmer</b>          |       |       |
| 020337-11 Disk, HEX and source files             | 4-90  | 8.65  |
| 020337-41 AT89C2051-12, programmed               | 6-25  | 11.05 |
| <b>No. 322 JUNE 2003</b>                         |       |       |
| <b>AVR TV Tennis</b>                             |       |       |
| 030026-1 Main PCB                                | 8-70  | 15.40 |
| 030026-2 Pushbutton PCB                          | 8-60  | 15.25 |
| 030026-11 Disk, AVR source code                  | 4-90  | 8.65  |
| 030026-41 AT908515, programmed                   | 15-20 | 26.90 |
| <b>Electronic Knotted Handkerchief</b>           |       |       |
| 020308-11 Disk, PC and controller software       | 4-90  | 8.65  |
| 020308-41 AT90S2313-10PC, programmed             | 12-60 | 22.30 |
| <b>Low-Cost LCD Controller (2)</b>               |       |       |
| 020114-1 PCB                                     | 8-70  | 15.35 |
| 020114-11 Disk, project software                 | 4-90  | 8.65  |
| <b>Night Light Control</b>                       |       |       |
| 020115-11 Disk, hex and source code              | 4-90  | 8.65  |
| 020115-41 AT90S2313-10PC, programmed             | 12-85 | 22.75 |
| <b>Universal XA Development Board</b>            |       |       |
| 010103-1 PCB                                     | 13-20 | 23.35 |
| 010103-11 Disk, GAL code, EPROM hex files, XADEV | 4-90  | 8.65  |
| 010103-21 EPROM IC8, 27C256-90, programmed       | 10-00 | 17.70 |
| 010103-22 EPROM IC9, 27C256-90, programmed       | 10-00 | 17.70 |
| 010103-31 GAL 16V8, programmed                   | 4-80  | 8.50  |
| <b>No. 321 MAY 2003</b>                          |       |       |
| <b>Countdown Timer</b>                           |       |       |
| 020296-11 Disk, source and hex code              | 4-90  | 8.65  |
| 020296-41 AT90S1200, programmed                  | 13-90 | 24.60 |
| <b>USB Audio Recorder</b>                        |       |       |
| 012013-11 Disk, EPROM hex code                   | 4-90  | 8.65  |
| 012013-21 EPROM 27C512, programmed               | 12-60 | 22.30 |
| <b>Valve Final Amp (2)</b>                       |       |       |
| 020071-2 Power supply board                      | 10-05 | 17.75 |

Products for older projects (if available) may be found on our web site  
<http://www.elektor-electronics.co.uk>



### LPC210x 'ARMeE' Development System (2)

Having digested the background article on ARM processors in the March 2005 issue you're ready to proceed with an ARM development board that follows in the footsteps of illustrious predecessors like our 'PICee' and 'AVRee' systems. A special feature of the project is the transportability (literally) of the ARM CPU sub-board — once programmed on the development system it can be unplugged from and migrated to a target application. Tony Dixon has the full story.

### USB-GPS

Unfortunately this article could not be included in the current issue due to lack of space. It describes an interface between navigation applications and a miniature GPS module coupled to an equally small active antenna. The modular structure of the project allows you to use selected parts for your own applications.

### SC-Analyser

Transistors are found in lots of electronic circuits. However, as many a repair engineer will avow, these components are not always easy to identify, which makes checking them — and finding a spare or substitute — a bit of a problem. Our SemiConductor Analyser is not only able to discriminate between FETs and bipolar transistors, but also snoop the pinout and extract the main electrical parameters like  $H_{FE}$  from an unknown device.



### Theme Plan for 2005

|                       |                    |
|-----------------------|--------------------|
| January . . . . .     | Power Supplies     |
| February . . . . .    | Wireless           |
| March . . . . .       | Sound              |
| April . . . . .       | Microcontrollers   |
| May . . . . .         | Sensors            |
| June . . . . .        | Environment        |
| July/August . . . . . | Summer Circuits    |
| September . . . . .   | Test & Measurement |
| October . . . . .     | Security           |
| November . . . . .    | CAD Software       |
| December . . . . .    | Optoelectronics    |

### Also...

Long Lines in Chips; Delphi Course (4); Simple LiPo Charger; 27C512 Emulator; The Digital Future.

**RESERVE YOUR COPY NOW!**

UK subscribers will receive the magazine a few days before this date.

The April 2005 issue goes on sale on Saturday 19 March 2005 (UK distribution only).

Article titles and magazine contents subject to change.

## NEWSAGENTS ORDER FORM

### SHOP SAVE / HOME DELIVERY

Please save / deliver one copy of *Elektor Electronics* magazine for me each month

Name: .....

Address: .....

Post code: .....

Telephone: .....

Date: .....

Signature: .....



Please cut out or photocopy this form, complete details and hand to your newsagent. *Elektor Electronics* is published on the third Friday of each month, except in July. Distribution S.O.R. by Seymour (NS).

## INDEX OF ADVERTISERS

|                                       |  |        |                               |  |        |
|---------------------------------------|--|--------|-------------------------------|--|--------|
| Allgood Technology, Net Links         | <a href="http://www.allgoodtechnology.com">www.allgoodtechnology.com</a>             | 80     | Milford Instruments           | <a href="http://www.milinst.demon.co.uk">www.milinst.demon.co.uk</a>         | 10     |
| Audioexpress, Net Links               | <a href="http://www.audioexpress.com">www.audioexpress.com</a>                       | 80     | MQP Electronics, Net Links    | <a href="http://www.mqpelectronics.co.uk">www.mqpelectronics.co.uk</a>       | 81     |
| Beta Layout, Net Links                | <a href="http://www.pcb-pool.com">www.pcb-pool.com</a>                               | 11, 80 | Net Links                     |  | 80, 81 |
| Burn Technology LTD, Net Links        | <a href="http://www.burntec.com">www.burntec.com</a>                                 | 80     | New Wave Concepts, Net Links  | <a href="http://www.new-wave-concepts.com">www.new-wave-concepts.com</a>     | 81     |
| CMS                                   | <a href="http://www.cms.uk.com">www.cms.uk.com</a>                                   | 61     | Number One Systems            | <a href="http://www.numberone.com">www.numberone.com</a>                     | 37     |
| Compucut, Net Links                   | <a href="http://www.compucutters.com">www.compucutters.com</a>                       | 80     | Nurve Networks                | <a href="http://www.xgamestation.com">www.xgamestation.com</a>               | 8      |
| Conford Electronics, Net Links        | <a href="http://www.confordelec.co.uk">www.confordelec.co.uk</a>                     | 80     | O2M8                          | <a href="http://www.o2m8.com">www.o2m8.com</a>                               | 11     |
| Cricklewood                           |  | 61     | PAGM                          | <a href="http://www.pagm.co.uk">www.pagm.co.uk</a>                           | 2      |
| Danbury, Net Links                    | <a href="http://www.livinginthepast.demon.co.uk">www.livinginthepast.demon.co.uk</a> | 80     | PCB World, Net Links          | <a href="http://www.pcbworld.org.uk">www.pcbworld.org.uk</a>                 | 81     |
| Debug Innovations, Net Links          | <a href="http://www.debuginnovations.com">www.debuginnovations.com</a>               | 80     | Peak Electronic, Net Links    | <a href="http://www.peakelec.co.uk">www.peakelec.co.uk</a>                   | 81     |
| Display Electronics                   | <a href="http://www.distel.co.uk">www.distel.co.uk</a>                               | 36     | PHYZX, Net Links              | <a href="http://www.phyzz.co.uk">www.phyzz.co.uk</a>                         | 81     |
| Easysync, Net Links                   | <a href="http://www.easysync.co.uk">www.easysync.co.uk</a>                           | 61, 80 | Picdos, Net Links             | <a href="http://www.picdos.com">www.picdos.com</a>                           | 81     |
| Elexol, Net Links                     | <a href="http://www.elexol.com">www.elexol.com</a>                                   | 80     | Pico                          | <a href="http://www.drdaq.com">www.drdaq.com</a>                             | 4, 37  |
| Elneq, Net Links                      | <a href="http://www.elneq.com">www.elneq.com</a>                                     | 80     | Quasar Electronics, Net Links | <a href="http://www.quasarelectronics.com">www.quasarelectronics.com</a>     | 72, 81 |
| Ervan International, Net Links        | <a href="http://www.ervan-int.com">www.ervan-int.com</a>                             | 80     | Robot Electronics, Net Links  | <a href="http://www.robot-electronics.co.uk">www.robot-electronics.co.uk</a> | 81     |
| Eurocircuits                          | <a href="http://www.thepcbshop.com">www.thepcbshop.com</a>                           | 79     | Technobots, Net Links         | <a href="http://www.technobots.co.uk">www.technobots.co.uk</a>               | 81     |
| ExpressPCB                            | <a href="http://www.expresspcb.com">www.expresspcb.com</a>                           | 11     | Telnet, Net Links             | <a href="http://www.telnet.uk.com">www.telnet.uk.com</a>                     | 81     |
| Forest, Net Links                     | <a href="http://www.fored.co.uk">www.fored.co.uk</a>                                 | 60, 80 | Ultraleds, Net Links          | <a href="http://www.ultraleds.co.uk">www.ultraleds.co.uk</a>                 | 81     |
| Future Technology Devices, Net Links  | <a href="http://www.ftdichip.com">www.ftdichip.com</a>                               | 80     | University of Derby           | <a href="http://www.vertigo.derby.ac.uk">www.vertigo.derby.ac.uk</a>         | 11     |
| Futurlec, Net Links                   | <a href="http://www.futurlec.com">www.futurlec.com</a>                               | 80     | USB Instruments, Net Links    | <a href="http://www.usb-instruments.com">www.usb-instruments.com</a>         | 81     |
| Hammond Electronics, Net Links        | <a href="http://www.hammondmfg.com">www.hammondmfg.com</a>                           | 80     | Viewcom, Net Links            | <a href="http://www.viewcom.f9.co.uk">www.viewcom.f9.co.uk</a>               | 81     |
| Hitex                                 | <a href="http://www.hitex.co.uk/arm">www.hitex.co.uk/arm</a>                         | 51     | Virtins Technology, Net Links | <a href="http://www.virtins.com">www.virtins.com</a>                         | 81     |
| ILP Electronics Limited, Net Links    | <a href="http://www.ilpelectronics.com">www.ilpelectronics.com</a>                   | 80     |                               |  |        |
| Ipeva Limited, Net Links              | <a href="http://www.ipeva.com">www.ipeva.com</a>                                     | 80     |                               |  |        |
| Jaycar Electronics                    | <a href="http://www.jaycarelectronics.co.uk">www.jaycarelectronics.co.uk</a>         | 3      |                               |  |        |
| JLB Electronics, Net Links            | <a href="http://www.jlbelectronics.com">www.jlbelectronics.com</a>                   | 80     |                               |  |        |
| Komcard, Net Links                    | <a href="http://www.komcard.com">www.komcard.com</a>                                 | 80     |                               |  |        |
| Labcenter                             | <a href="http://www.labcenter.co.uk">www.labcenter.co.uk</a>                         | 88     |                               |  |        |
| London Electronics College, Net Links | <a href="http://www.lec.org.uk">www.lec.org.uk</a>                                   | 80     |                               |  |        |
| Matrix Multimedia Ltd                 | <a href="http://www.matrixmultimedia.co.uk">www.matrixmultimedia.co.uk</a>           | 41     |                               |  |        |

Advertising space for the issue of 19 April 2005 may be reserved not later than 22 March 2005

with Huson International Media — Cambridge House — Gogmore Lane — Chertsey, Surrey KT16 9AP — England — Telephone 01932 564 999 — Fax 01932 564998 — e-mail: [gerryb@husonmedia.com](mailto:gerryb@husonmedia.com) to whom all correspondence, copy instructions and artwork should be addressed.



## ORDERING INSTRUCTIONS, P&P CHARGES

Except in the USA and Canada, all orders, except for subscriptions (for which see below), must be sent BY POST or FAX to our Tunbridge Wells address using the Order Form overleaf. On-line ordering: <http://www.elektor-electronics.co.uk>

**Readers in the USA and Canada** may (but are not obliged to) send orders, except for subscriptions (for which see below), to the USA address given on the order form. Please apply to Old Colony Sound for applicable P&P charges. Please allow 4-6 weeks for delivery.

**Orders placed on our Tunbridge Wells office** must include P&P charges (Priority or Standard) as follows:

UK: £4.00 Europe: £5.00 (Standard) or £7.00 (Priority) Outside Europe: £8.00 (Standard) or £12.00 (Priority)

## HOW TO PAY

Unless you have an approved credit account with us, all orders must be accompanied by the full payment, including postage and packing charges as stated above. Payment may be made by cheque drawn on a London clearing bank (but see para. 4 below), postal order, VISA, Access, MasterCard or EuroCard (when paying by credit card, the order must go the cardholder's address). Do not send cash through the mail. Cheques and postal orders should be crossed and made payable to 'Elektor Electronics (Publishing)'. Payment may also be made by direct transfer from a private or business Giro account to our **Giro account No. 34-152-3801** by completing and sending to the National Giro Centre, in a National Giro postage paid envelope, a National Giro transfer/deposit form. Do not send Giro transfers direct to us, as this will delay your order. If you live outside the UK, payment may also be made by Bankers' sterling draft drawn on a London clearing bank, Eurocheque made out in pounds sterling (with holder's guarantee card number written on the back), or US or Canadian dollar cheque drawn on a US or Canadian bank. If you pay by Bankers' sterling draft, make clear to the issuing bank that your full name and address MUST be communicated to the London clearing bank. Our bankers are **NAT WEST PLC, 1 St James's Square, Wadhurst, East Sussex TN5 6BH, England. Our account number is 3512 5225, Sorting Code 60-22-15. IBAN code: GB40 NWB K6 022 15 3512 5225 BIC code: NWB KGB 2L**

## COMPONENTS

Components for projects appearing in Elektor Electronics are usually available from certain advertisers in this magazine. If difficulties in the supply of components are envisaged, a source will normally be advised in the article. Note, however, that the source(s) given is (are) not exclusive.

## TERMS OF BUSINESS

**Delivery** Although every effort will be made to dispatch your order within 2-3 weeks from receipt of your instructions, we can not guarantee this time scale for all orders. **Returns** Faulty goods or goods sent in error may be returned for replacement or refund, but not before obtaining our consent. All goods returned should be packed securely in a padded bag or box, enclosing a covering letter stating the dispatch note number. If the goods are returned because of a mistake on our part, we will refund the return postage. **Damaged goods** Claims for damaged goods must be received at our Tunbridge Wells office within 10-days (UK); 14-days (Europe) or 21-days (all other countries). **Cancelled orders** All cancelled orders will be subject to a 10% handling charge with a minimum charge of £5.00. **Patents** Patent protection may exist in respect of circuits, devices, components, and so on, described in our books and magazines. Elektor Electronics (Publishing) does not accept responsibility or liability for failing to identify such patent or other protection. **Copyright** All drawings, photographs, articles, printed circuit boards, programmed integrated circuits, diskettes and software carriers published in our books and magazines (other than in third-party advertisements) are copyright and may not be reproduced or transmitted in any form or by any means, including photocopying and recording, in whole or in part, without the prior permission of Elektor Electronics (Publishing) in writing. Such written permission must also be obtained before any part of these publications is stored in a retrieval system of any nature. Notwithstanding the above, printed-circuit boards may be produced for private and personal use without prior permission. **Limitation of liability** Elektor Electronics (Publishing) shall not be liable in contract, tort, or otherwise, for any loss or damage suffered by the purchaser whatsoever or howsoever arising out of, or in connexion with, the supply of goods or services by Elektor Electronics (Publishing) other than to supply goods as described or, at the option of Elektor Electronics (Publishing), to refund the purchaser any money paid in respect of the goods. **Law** Any question relating to the supply of goods and services by Elektor Electronics (Publishing) shall be determined in all respects by the laws of England.

January 2005

## SUBSCRIPTION RATES FOR ANNUAL SUBSCRIPTION

|                                      | Standard  | Plus      |
|--------------------------------------|-----------|-----------|
| United Kingdom                       | £39.50    | £46.00    |
| Economy Mail                         |           |           |
| Rest of the World (excluding Europe) | £51.30    | £57.80    |
| Priority Airmail                     |           |           |
| Europe & Eire                        | £52.50    | £59.00    |
| Outside Europe                       | £65.00    | £71.50    |
| Airfreight                           |           |           |
| USA & Canada only                    | US\$88.00 | US\$98.00 |

### Payment should be made by:

- Cheque or bankers' draft in sterling drawn on a London clearing bank (except in the USA and Canada — see below);
- US\$ cheques drawn on a US or Canadian bank — only by subscribers in the USA or Canada.
- Direct transfer to our bank (NAT WEST PLC, 1 St James's Square, Wadhurst, East Sussex TN5 6BH, England). Our account number is 3512 5225, Sorting Code 60-22-15. IBAN code: GB40 NWB K6 022 15 3512 5225 BIC code: NWB KGB 2L
- Postal order.
- Credit card: VISA, ACCESS, Euro/MasterCard, JCB Electron or Switch.
- Transfer to our Giro Account number 34 152 3801. Giro transfers should be made by completing and sending the appropriate transfer/deposit form to the National Giro Centre (UK) or to your national Giro Centre.

Cheques and postal orders should be made payable to Elektor Electronics (Publishing). Do not send cash through the mail.

## SUBSCRIPTION RATES FOR 18-MONTH SUBSCRIPTION

|                                      | Standard   | Plus       |
|--------------------------------------|------------|------------|
| United Kingdom                       | £59.25     | £69.00     |
| Economy Mail                         |            |            |
| Rest of the World (excluding Europe) | £76.95     | £86.70     |
| Priority Airmail                     |            |            |
| Europe & Eire                        | £78.75     | £88.50     |
| Outside Europe                       | £97.50     | £107.25    |
| Airfreight                           |            |            |
| USA & Canada only                    | US\$132.00 | US\$147.00 |

## SUBSCRIPTION CONDITIONS

The standard subscription order period is twelve months. If a permanent change of address during the subscription period means that copies have to be despatched by a more expensive service, no extra charge will be made. Conversely, no refund will be made, nor expiry date extended, if a change of address allows the use of a cheaper service. Student applications, which qualify for a 20% (twenty per cent) reduction in current rates, must be supported by evidence of studentship signed by the head of the college, school or university faculty. A standard Student Subscription costs £31.60, a Student Subscription-Plus costs £37.60 (UK only). Please note that new subscriptions take about four weeks from receipt of order to become effective. Cancelled subscriptions will be subject to a charge of 25% (twenty-five per cent) of the full subscription price or £7.50, whichever is the higher, plus the cost of any issues already dispatched. Subscriptions cannot be cancelled after they have run for six months or more.

January 2005

Order now using the Order Form in the Readers Services section in this issue.

More information on [www.elektor-electronics.co.uk](http://www.elektor-electronics.co.uk)

## CD-ROM Audio Collection 2

A unique CD-ROM for the true audio lover, containing no fewer than 75 audio designs from the past five year volumes of elektor electronics magazine.

The articles on the CD-ROM cover test & measurement equipment, amplifiers, digital audio and loudspeaker technology. Highlights include the Crescendo Millennium Edition, Audio-DAC 2000, Audio-ADC 2000 and the

IR-S/PDIF Transmitter and Receiver. Using the included Acrobat Reader you are able to browse the articles on your computer, as well as print texts, circuit diagrams and PCB layouts.

£12.05 (US\$ 21.25)

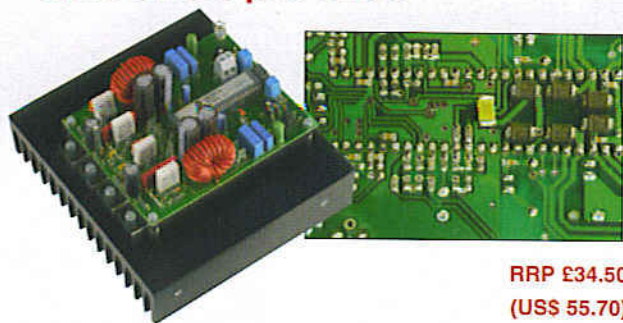


Also available:

**Volume 1:** More than 75 audio circuits from the 1996-1999 volumes of Elektor Electronics magazine.

£12.05 (US\$21.25)

## 2x300W Amplifier board with SMDs pre-fitted



RRP £34.50  
(US\$ 55.70)

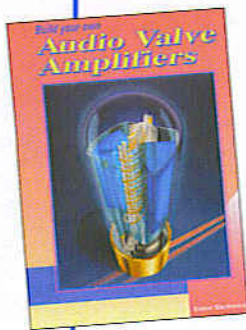
This top-end amplifier proves that high power does not have to mean a large, heavy design. Although this amplifier is highly efficient (and thus compact), its specifications easily surpass those of quite a few conventional designs.

This 2 x 300 watt amplifier board has modest dimensions thanks to the use of SMD parts fitted at the underside. Elektor Electronics greatly simplifies building this project by offering the stereo amplifier board with all SMD parts already mounted, for just £34.50 (or US\$55.70)! Also included are the two toroid cores for the output filters.

More information on this powerhouse may be found in the June and September 2004 issues of Elektor Electronics magazine.

## AUDIO BOOKS

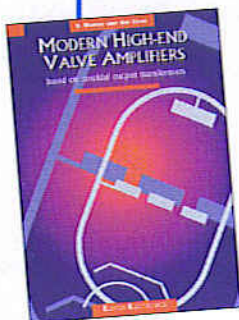
### Build your own Audio Valve Amplifiers



To many people, the thermionic valve or electron tube is history. However, whether it is nostalgia, interest in the technical parameters, the appeal of a gleaming amplifier chassis with softly glowing valves or perhaps the firm conviction that the sound of a valve cannot be bettered, it is a fact that the valve is making a come-back. This book contains, apart from construction projects for preamplifiers, power amplifiers, and amplifiers for musical instruments, information on the operation of electron tubes, while the first chapter gives a short history of the valve.

ISBN 0 905705 39 4 • 253 Pages • £15.55 (US\$31.00)

### Modern High-end Valve Amplifiers



Valve amplifiers are regarded by many to be the ne plus ultra when it comes to processing audio signals. The combination of classical technology and modern components has resulted in a revival of the valve amplifier. The use of toroidal-core output transformers, developed by the author over the past 15 years, has contributed to this revival. This book explains the whys and wherefores of toroidal output transformers at various technical levels and offers innovative solutions for achieving perfect audio quality.

ISBN 0 905705 63 7 • 264 Pages • £25.95 (US\$52.00)

### Build your own High-End Audio Equipment

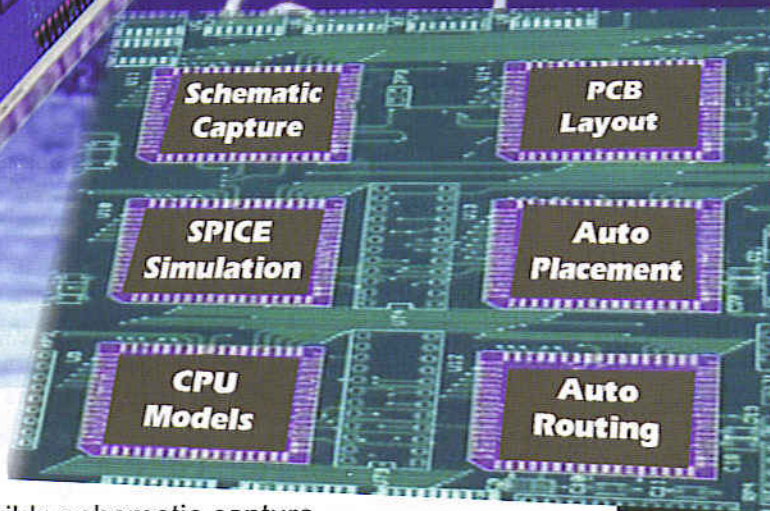
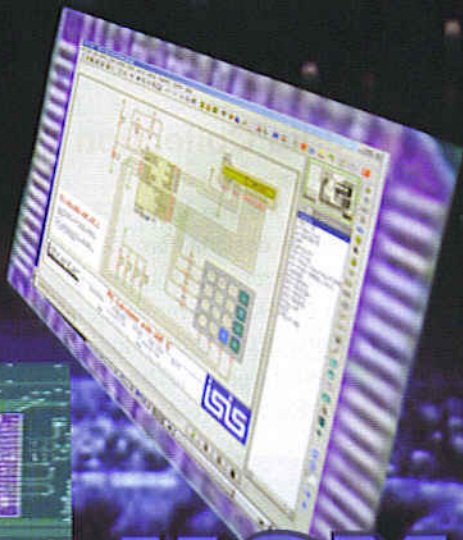
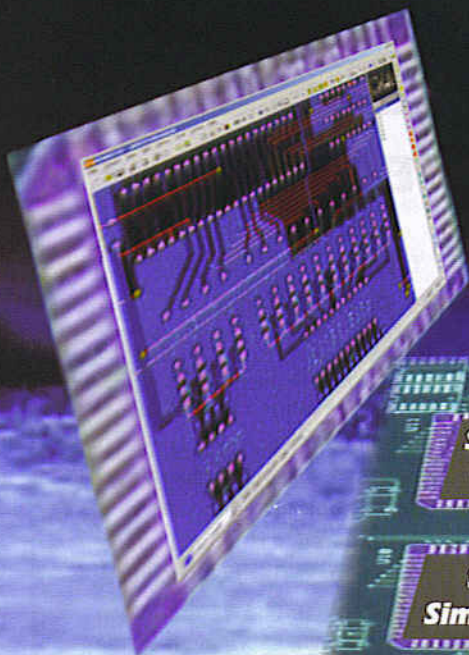


The name high-end equipment is a good indication of the prices charged for it. For those who cannot, or will not, pay these high prices, there is a solution offered in this book: build your own at considerable cost savings. This book is aimed not only at this sector of the market, but also at the many enthusiasts who want to be able to experiment and to make their own modifications to their high-end equipment. Contents include solid-state and valve preamplifiers and power amplifiers, active crossover filters, an active subwoofer, a head-phone amplifier and more.

ISBN 0 905705 40 8 • 262 Pages • £15.55 (US\$31.00)

# PROTEUS

*The Complete Electronics Design System*



## VSM

Virtual System Modelling

### Schematic & PCB Layout

- Powerful & flexible schematic capture.
- Auto-component placement and rip-up/retry PCB routing.
- Polygonal gridless ground planes.
- Libraries of over 8000 schematic and 1000 PCB parts.
- Bill of materials, DRC reports and much more.

### Mixed Mode SPICE Circuit Simulation

- Berkeley SPICE3F5 simulator with custom extensions for true mixed mode and interactive simulation.
- 6 virtual instruments and 14 graph based analysis types.
- 6000 models including TTL, CMOS and PLD digital parts.
- Fully compatible with manufacturers' SPICE models.

### Proteus VSM - Co-simulation and debugging for popular Micro-controllers

- Supports PIC, AVR, 8051, and BASIC STAMP micro-controllers.
- Co-simulate target firmware with your hardware design.
- Includes interactive peripheral models for LED and LCD displays, switches, keypads, virtual terminal and much, much more.
- Compatible with popular compilers and assemblers from Microchip, Crownhill, IAR, Keil, and others.

## New Features in Version 6.5

- Textual library part search.
- User defined keyboard map.
- CAD/CAM output to ZIP file.
- Bitmap import function.
- TrueType fonts on PCBs.
- Enhanced printer output.

*Call Now for Upgrade Pricing*

labcenter

Electronics  
53-55 Main Street, Grassington. BD23 5AA

Tel: 01756 753440  
Fax: 01756 752857

Contact us for  
**Free Demo CD**

**NEW**  
**ELECTRA**  
SHAPE BASED  
AUTOROUTER  
NOW AVAILABLE

[www.labcenter.co.uk](http://www.labcenter.co.uk)  
[info@labcenter.co.uk](mailto:info@labcenter.co.uk)