

USER'S MANUAL

OMNUC U SERIES

MODELS R88M-U□
(AC Servomotors)

MODELS R88D-UP□
(AC Servo Drivers)

AC SERVOMOTORS/DRIVERS (30 to 750-W Pulse-train Inputs)

Thank you for choosing this OMNUC UP-series product.

This manual provides details on the installation, wiring, troubleshooting, and maintenance of OMNUC UP-series products along with parameter settings for the operation of the products.

- Make sure that actual users of this product will read this manual thoroughly and handle and operate the product with care.
- Retain this manual for future reference.
- This manual describes the specifications and functions of the product and relations with other products. Assume that nothing described in this manual is possible.
- Specifications and functions may change without notice to improve product performance.
- Forward and reverse rotation of AC Servomotors described in this manual are defined as looking at the end of the output shaft of the motor as follows: counterclockwise rotation (CCW) is forward and clockwise rotation (CW) is reverse.

General Instructions

1. Refer to Precautions first and carefully read and be sure to understand the information provided.
2. Familiarize yourself with this manual and understand the functions and performance of the Servomotor and Servo Driver for proper use.
3. The Servomotor and Servo Driver must be wired and the Parameter Unit must be operated by experts in electrical engineering.
4. We recommend that you add the following precautions to any instruction manuals you prepare for the system into which the product is being installed.
 - Precautions on the dangers of high-voltage equipment.
 - Precautions on touching the terminals of the product even after power has been turned off. (These terminals are live even with the power turned off.)
5. Do not perform withstand voltage or other megameter tests on the product. Doing so may damage internal components.
6. Servomotors and Servo Drivers have a finite service life. Be sure to keep replacement products on hand and to consider the operating environment and other conditions affecting the service life.
7. Do not set any parameter not described in this manual, otherwise the Servomotor or Servo Driver may malfunction. Contact your OMRON representatives if you have any inquiry.
8. The functions and specifications differ for the various models, as shown below. Be sure to check which models are being used before proceeding.
 - HA/LA/V/W AC Servo Drivers: R88D-UP□□HA, R88D-UP□□LA, R88D-UP□□V, and R88D-UP□□W
 - H/L AC Servo Drivers: R88D-UP□□H and R88D-UP□□L

NOTICE

Before using the product under the following conditions, consult your OMRON representatives, make sure that the ratings and performance characteristics of the product are good enough for the systems, machines, or equipment, and be sure to provide the systems, machines, or equipment with double safety mechanisms.

1. Conditions not described in the manual.
2. The application of the product to nuclear control systems, railroad systems, aviation systems, vehicles, combustion systems, medical equipment, amusement machines, or safety equipment.
3. The application of the product to systems, machines, or equipment that may have a serious influence on human life and property if they are used improperly.

Items to Check After Unpacking

Check the following items after removing the product from the package:

- Has the correct product been delivered (i.e., the correct model number and specifications)?
- Has the product been damaged in shipping?

The product is provided with this manual. No connectors or mounting screws are provided.

Notice:

OMRON products are manufactured for use according to proper procedures by a qualified operator and only for the purposes described in this manual.

The following conventions are used to indicate and classify precautions in this manual. Always heed the information provided with them. Failure to heed precautions can result in injury to people or damage to property.

 **DANGER** Indicates an imminently hazardous situation which, if not avoided, will result in death or serious injury.

 **WARNING** Indicates a potentially hazardous situation which, if not avoided, could result in death or serious injury.

 **Caution** Indicates a potentially hazardous situation which, if not avoided, may result in minor or moderate injury, or property damage.

OMRON Product References

All OMRON products are capitalized in this manual. The word “Unit” is also capitalized when it refers to an OMRON product, regardless of whether or not it appears in the proper name of the product.

The abbreviation “Ch,” which appears in some displays and on some OMRON products, often means “word” and is abbreviated “Wd” in documentation in this sense.

The abbreviation “PC” means Programmable Controller and is not used as an abbreviation for anything else.

Visual Aids

The following headings appear in the left column of the manual to help you locate different types of information.

Note Indicates information of particular interest for efficient and convenient operation of the product.

© OMRON, 1994

All rights reserved. No part of this publication may be reproduced, stored in a retrieval system, or transmitted, in any form, or by any means, mechanical, electronic, photocopying, recording, or otherwise, without the prior written permission of OMRON.

No patent liability is assumed with respect to the use of the information contained herein. Moreover, because OMRON is constantly striving to improve its high-quality products, the information contained in this manual is subject to change without notice. Every precaution has been taken in the preparation of this manual. Nevertheless, OMRON assumes no responsibility for errors or omissions. Neither is any liability assumed for damages resulting from the use of the information contained in this publication.

General Warnings

Observe the following warnings when using the OMNUC Servomotor and Servo Driver.

This manual may include illustrations of the product with protective covers removed in order to describe the components of the product in detail. Make sure that these protective covers are on the product before use.

Consult your OMRON representative when using the product after a long period of storage.

-  **WARNING** Always connect the frame ground terminals of the Servo Driver and the Servomotor to a class-3 ground (to 100 Ω or less). Not connecting to a class-3 ground may result in electric shock.

-  **WARNING** Do not touch the inside of the Servo Driver. Doing so may result in electric shock.

-  **WARNING** Do not remove the front cover, terminal covers, cables, Parameter Units, or optional items while the power is being supplied. Doing so may result in electric shock.

-  **WARNING** Operation, maintenance, or inspection must be performed by authorized personnel. Not doing so may result in electric shock or injury.

-  **WARNING** Wiring or inspection must be performed at least 5 minutes after turning off the power supply. Doing so may result in electric shock.

-  **WARNING** Do not damage, press, or put excessive stress or heavy objects on the cables. Doing so may result in electric shock.

-  **WARNING** Do not touch the rotating parts of the Servomotor under operation. Doing so may result in injury.

-  **WARNING** Do not modify the product. Doing so may result in injury or damage to the product.

-  **Caution** Use the Servomotors and Servo Drivers in a specified combination. Doing so may result in fire or damage to the products.

-  **Caution** Do not store or install in the following places. Doing so may result in fire or damage to the Product.
 - Locations subject to direct sunlight.
 - Locations subject to temperatures or humidity outside the range specified in the specifications.
 - Locations subject to condensation as the result of severe changes in temperature.
 - Locations subject to corrosive or flammable gases.
 - Locations subject to dust (especially iron dust) or salts.
 - Locations subject to shock or vibration.
 - Locations subject to exposure to water, oil, or chemicals.

 **Caution** Do not touch the Servo Driver radiator or Servomotor while the power is being supplied or soon after the power is turned off. Doing so may result in a skin burn due to the hot surface.

Storage and Transportation Precautions

 **Caution** Do not hold by the cables or motor shaft while transporting the product. Doing so may result in injury or malfunction.

 **Caution** Do not place any load exceeding the figure indicated on the product. Doing so may result in injury or malfunction.

 **Caution** Use the motor eye-bolts only for transporting the Motor. Using them for transporting the machinery may result in injury or malfunction.

Installation and Wiring Precautions

 **Caution** Do not step on or place a heavy object on the product. Doing so may result in injury.

 **Caution** Do not cover the inlet or outlet ports and prevent any foreign objects from entering the product. Doing so may result in fire.

 **Caution** Be sure to install the product in the correct direction. Not doing so may result in malfunction.

 **Caution** Provide the specified clearances between the Servo Driver and the control panel or with other devices. Not doing so may result in fire or malfunction.





 **Caution** Do not apply any strong impact. Doing so may result in malfunction.

 **Caution** Be sure to wire correctly and securely. Not doing so may result in motor runaway, injury, or malfunction.







 **Caution** Be sure that all the mounting screws, terminal screws, and cable connector screws are tightened to the torque specified in the relevant manuals. Incorrect tightening torque may result in malfunction.

 **Caution** Use crimp terminals for wiring. Do not connect bare stranded wires directly to terminals. Connection of bare stranded wires may result in burning.

 **Caution** Always use the power supply voltage specified in the User's Manual. An incorrect voltage may result in malfunction or burning.

-  **Caution** Take appropriate measures to ensure that the specified power with the rated voltage and frequency is supplied. Be particularly careful in places where the power supply is unstable. An incorrect power supply may result in malfunction.
-  **Caution** Install external breakers and take other safety measures against short-circuiting in external wiring. Insufficient safety measures against short-circuiting may result in burning.
-  **Caution** Provide an appropriate stopping device on the machine side to secure safety. (A holding brake is not a stopping device for securing safety.) Not doing so may result in injury.
-  **Caution** Provide an external emergency stopping device that allows an instantaneous stop of operation and power interruption. Not doing so may result in injury.
-  **Caution** Take appropriate and sufficient countermeasures when installing systems in the following locations:
- Locations subject to static electricity or other forms of noise.
 - Locations subject to strong electromagnetic fields and magnetic fields.
 - Locations subject to possible exposure to radioactivity.
 - Locations close to power supplies.

Operation and Adjustment Precautions

-  **Caution** Check the newly set parameters for proper execution before actually running them. Not doing so may result in equipment damage.
-  **Caution** Do not make any extreme adjustments or setting changes. Doing so may result in unstable operation and injury.
-  **Caution** Separate the Servomotor from the machine, check for proper operation, and then connect to the machine. Not doing so may cause injury.
-  **Caution** When an alarm occurs, remove the cause, reset the alarm after confirming safety, and then resume operation. Not doing so may result in injury.
-  **Caution** Do not come close to the machine immediately after resetting momentary power interruption to avoid an unexpected restart. (Take appropriate measures to secure safety against an unexpected restart.) Doing so may result in injury.
-  **Caution** Do not use the built-in brake of the Servomotor for ordinary braking. Doing so may result in malfunction.

Maintenance and Inspection Precautions

⚠ WARNING Do not attempt to disassemble, repair, or modify any Units. Any attempt to do so may result in malfunction, fire, or electric shock.

⚠ Caution Resume operation only after transferring to the new Unit the contents of the data required for operation. Not doing so may result in an unexpected operation.

Warning Labels

Warning labels are pasted on the product as shown in the following illustration. Be sure to follow the instructions given there.

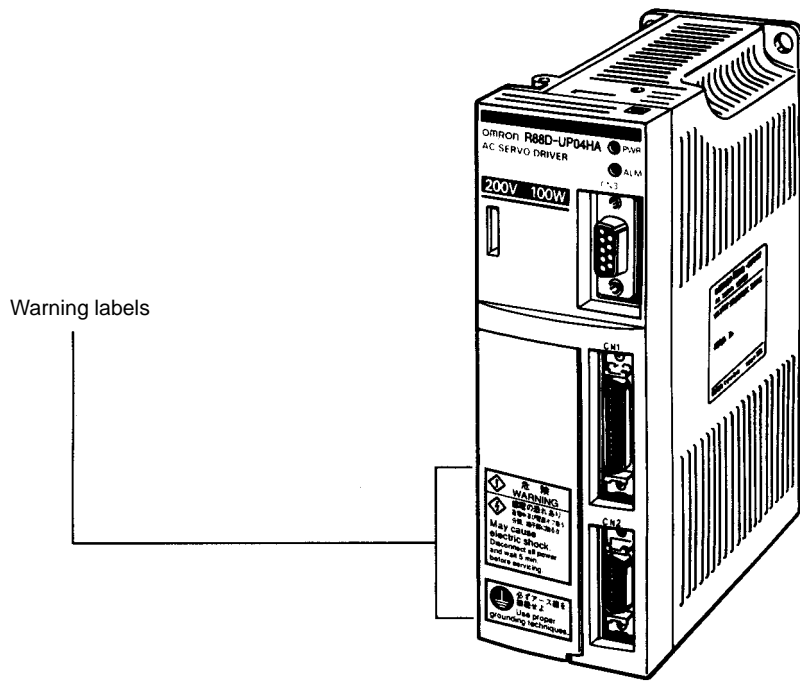

Warning Labels for Non-conforming Models



Warning label 1



Warning label 2

Warning Labels for Models Conforming to EC Directives



Warning label 1



Warning label 2

VISUAL INDEX

For users who wish to operate soon.

- The following portions of this manual provide the minimum information required for operation. Be sure you fully understand at least the information in these portions before attempting operation.

Chapter 2 System Design and Installation, and sections 3-1, 3-2, 3-3, 3-4, 3-5, and 3-6 of Chapter 3 Operation.

Instructions for jog operation using a Parameter Unit are provided in 3-6.

SYSMAC CS1/C/CV
Programmable Controller

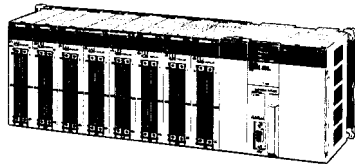

Position Control Unit

C200HW-NC113
C200HW-NC213
C200HW-NC413
C200H-NC112
C200H-NC211
C500-NC113
C500-NC211

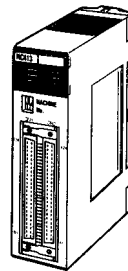

Pulse input

Controller Connecting Cable
Chapter 5: 5-3-1



OMNUC U is a series of fully software-controlled AC servo drivers built on advanced OMRON software servo technology. It provides high performance, a sensitive man-machine interface, and economy.

Setting Functions

<input type="checkbox"/> Setting User Parameters:	Section 3-5-1
<input type="checkbox"/> Internally Set Speed Control:	Section 3-5-3
<input type="checkbox"/> Electronic Gears:	Section 3-5-4
<input type="checkbox"/> Encoder Dividing:	Section 3-5-5
<input type="checkbox"/> Bias:	Section 3-5-6
<input type="checkbox"/> Torque Control:	Section 3-5-7
<input type="checkbox"/> Brake Interlock:	Section 3-5-8

Adjustments and Troubleshooting

<input type="checkbox"/> Adjustments:	Section 3-7
<input type="checkbox"/> Displays:	Section 4-1
<input type="checkbox"/> Monitor Outputs:	Section 4-2
<input type="checkbox"/> Protections and Diagnostics:	Section 4-3
<input type="checkbox"/> Troubleshooting:	Section 4-4

OMNUC U Series

OMNUC U-series AC Servo Driver

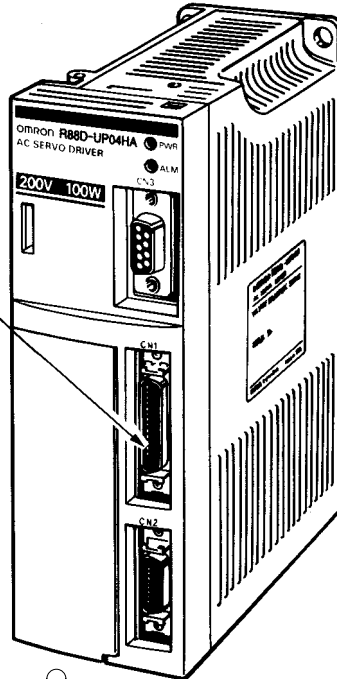

I/O Operations
Chapter 5: 5-1-3

Cable Specifications
Chapter 5: 5-3-2, 5-3-3

Encoder
signals

Power
signals

OMNUC U-series
AC Servomotor

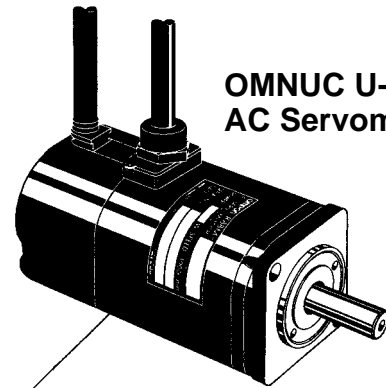

Motor Specifications
Chapter 5: 5-2

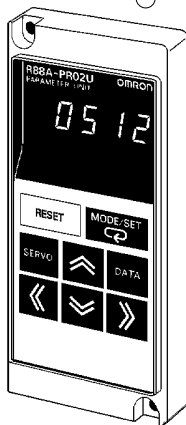

Parameter Units

Operation Method
Chapter 3: 3-3, 3-4, 3-5

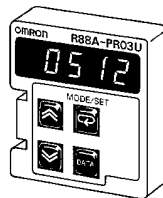

Table of Contents

Chapter 1. Introduction

- 1-1 Features
- 1-2 System Configuration
- 1-3 Servo Driver Nomenclature
- 1-4 Applicable Standards and Models
- 1-4-1 UL/cUL Standards
- 1-4-2 EC Directives

Chapter 2. System Design and Installation

- 2-1 Installation
- 2-1-1 External Dimensions (Unit: mm)
- 2-1-2 Installation Conditions
- 2-2 Wiring Products Conforming to UL/cUL
and Wiring Products Not Conforming to Any Standards
- 2-2-1 Connecting OMRON Servo Controllers
- 2-2-2 Connector-Terminal Conversion Unit
- 2-2-3 Wiring Servo Drivers
- 2-2-4 Wiring for Noise Resistance
- 2-2-5 Peripheral Device Connection Examples
- 2-3 Wiring Products Conforming to EC Directives
- 2-3-1 Connecting Servo Controllers
- 2-3-2 Wiring Servo Drivers
- 2-3-3 Wiring Products Conforming to EMC Directives
- 2-3-4 Peripheral Device Connection Examples

Chapter 3. Operation

- 3-1 Operational Procedure
- 3-2 Turning On Power and Checking Displays
- 3-2-1 Items to Check Before Turning On Power
- 3-2-2 Turning On Power and Confirming the Display
- 3-3 Using Parameter Units
- 3-3-1 Parameter Unit Keys and Functions
- 3-3-2 Modes and Changing Modes
- 3-3-3 Mode Changes and Display Contents
- 3-4 Initial Settings: Setup Parameters
- 3-4-1 Setting and Checking Setup Parameters (Cn-01, 02)
- 3-4-2 Setup Parameter Contents
- 3-4-3 Important Setup Parameters (Cn-01 and Cn-02)
- 3-5 Setting Functions: User Parameters
- 3-5-1 Setting and Checking User Parameters (Cn-04 to 29)
- 3-5-2 User Parameter Chart
- 3-5-3 Internal Speed Control Settings
- 3-5-4 Electronic Gear Function: Position Control
- 3-5-5 Encoder Dividing Function
- 3-5-6 Bias Function: Position Control
- 3-5-7 Torque Limit Function
- 3-5-8 Brake Interlock (For Motors with Brakes)
- 3-6 Trial Operation
- 3-6-1 Preparations for Trial Operation
- 3-6-2 Jog Operations

Table of Contents

3-7	Making Adjustments	
3-7-1	Auto-tuning	
3-7-2	Manually Adjusting Gain	
3-8	Regenerative Energy Absorption	
3-8-1	Calculating Regenerative Energy	
3-8-2	Servo Driver Absorbable Regenerative Energy	
3-8-3	Absorption of Regenerative Energy with the External Regeneration Resistor (Models Conforming to UL/cUL Standards and Models Not Conforming to Any Standards)	
3-8-4	Processing Regenerative Energy with Multiple Axes (Models Conforming to EC Directives)	

Chapter 4. Application

4-1	Using Displays	
4-1-1	Display Functions	
4-1-2	Status Display Mode	
4-1-3	Monitor Mode (Un-)	
4-1-4	Checking Servomotor Parameters (Cn-00 Set to 04)	
4-2	Using the Monitor Output	
4-3	Protective and Diagnostic Functions	
4-3-1	Alarm Displays and Alarm Code Outputs	
4-3-2	Alarm Output	
4-3-3	Overload Characteristics (Electron Thermal Characteristics)	
4-3-4	Alarm History Display Mode	
4-4	Troubleshooting	
4-5	Periodic Maintenance	

Chapter 5. Specifications

5-1	Servo Driver Specifications	
5-1-1	General Specifications	
5-1-2	Performance Specifications	
5-1-3	I/O Specifications	
5-1-4	Explanation of User Parameters	
5-2	Servomotor Specifications	
5-2-1	General Specifications	
5-2-2	Performance Specifications	
5-2-3	Torque and Rotational Speed Characteristics	
5-2-4	Allowable Loads on Servomotor Shafts	
5-2-5	Encoder Specifications	
5-3	Cable Specifications	
5-3-1	Controller Connecting Cables	
5-3-2	Encoder Cables	
5-3-3	Power Cable	
5-4	Parameter Unit Specifications	
5-5	Regeneration Unit Specifications	
5-6	Front-surface Mounting Bracket Specifications	

Chapter 6. Supplementary Materials

6-1	Connection Examples	
6-2	Servo Connector Terminal Connection Unit	
6-3	OMNUC U-series Standard Models	
6-4	Parameter Setting Forms	

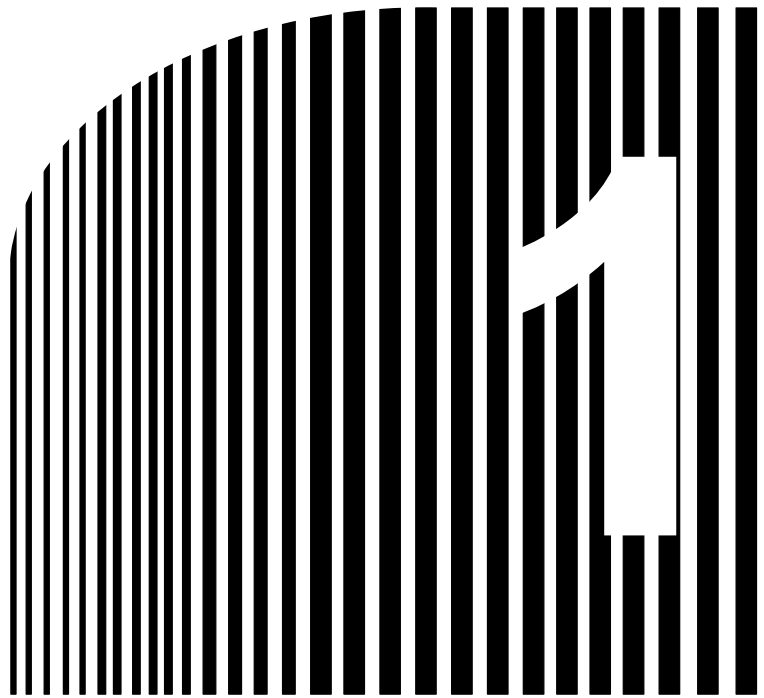

Chapter 1

• Introduction •

- 1-1 Features
- 1-2 System Configuration
- 1-3 Servo Driver Nomenclature
- 1-4 Applicable Standards and Models

1-1 Features

OMNUC AC Servo Drivers control the power supplied to AC Servomotors with pulse-train input signals and perform precision position control. There are 7 types of AC Servomotors: 30-W, 50-W, 100-W, 200-W, 300-W, 400-W, and 750-W.

Motor Output Capacity

AC Servomotors with the following output capacities are available.

For 200/230-VAC (170 to 253 V) single-phase, 50/60-Hz Input
30 W, 50 W, 100 W, 200 W, 400 W, and 750 W

For 100/115-VAC (85 to 127 V) single-phase, 50/60-Hz Input
30 W, 50 W, 100 W, 200 W, and 300 W

The Servomotors also come with and without brakes, and with and without keys on the straight shaft. Servomotors that conform to EC Directives, however, are available only with keys on the shaft.

Models Conforming to UL/cUL Standards Available (UL/cUL Markings)

AC Servomotors and Servo Drivers that conform to UL/cUL Standards are now available. Their performance, functionality, and appearance are the same as the conventional U-series (HA/LA) models. They are useful for obtaining approvals required for specific applications.

Models conforming to UL/cUL Standards have the same product names as conventional U-series (HA/LA) models. As shown in the following table, they are distinguished by the manufacturing date.

Model	Manufacturing date	Type	Remarks
Models not conforming to any standards	Before April 1998	H/L, HA/LA	Production of H/L models discontinued.
Models conforming to UL/cUL Standards	After May 1998	HA/LA	UL/cUL markings are attached to products.

EC Directives (CE Markings)

AC Servomotors and Servo Drivers that conform to EC low-voltage and EMC directives are now available. These provide the same performance and functions as the rest of the U Series (HA/LA), and will aid in obtaining specifications.

Control Functions

Any one of the following 4 control modes can be selected in the parameter settings.

Position Control (Factory Setting)

Controls the position and speed of the Servomotor very precisely with pulse-train input signals. Any one of the following 3 pulse trains can be selected: forward/reverse pulses, feed pulses/directional signals, or 90° differential phase (A/B phases) signals.

Position Control with Pulse Stop Input Enabled (HA/LA/V/W Models)

Turning ON the Pulse Stop Input (IPG) prevents the control signals from being read by the Unit during position control.

Internal Speed Control Settings

The speed of the motor is controlled with the three speeds (No. 1, No. 2, and No. 3 internal speed settings) set in the parameters. This mode is effective for simple position control or speed-switching operation.

Internal Speed Control Setting + Position Control (HA/LA/V/W Models)

Speed control can be performed with the internal speed settings and position control can be performed with pulse-train inputs.

Auto-tuning

The gain can be adjusted automatically when the responsiveness has been selected to match the rigidity of the mechanical system. The auto-tuning feature automatically finds the optimum adjustment to match the load, with no need for difficult operations.

Monitor

Displays the driver's operating status on the Parameter Unit.

The following items can be monitored: speed feedback, speed commands, torque commands, number of pulses from the U-phase edge, electrical angle, internal status (bit display), command pulse's speed, position deviation, and the input pulse counter.

Jog Operation

Forward/Reverse motor operation can be controlled from the Parameter Unit. Rotational speed can be set in the parameters.

Electronic Gear Function (Position Control)

The number of pulses used to rotate the motor is calculated by multiplying the number of command pulses by the electronic gear ratio. This function is useful in the following kinds of cases.

When you want to finely adjust the position and speed of two lines that need to be synchronized

When you want to increase the control pulse frequency of a controller with a low pulse frequency

When you want to set the movement/pulse to a certain amount, such as 0.01 mm/pulse

The electronic gear ratio is set with parameters G1 and G2 (G1=numerator and G2=denominator). The setting range for parameters G1 and G2 is 1 to 65,535. The setting range for the gear ratio is 0.01 to 100, i.e., $0.01 \leq G1/G2 \leq 100$.

Encoder Resolution Function

This function allows the encoder signal output from the driver to be set anywhere from 16 to 2,048 pulses/revolution.

Software Start Function (Internal Speed Control Settings)

This function causes the motor to be started/stopped in the preset acceleration/deceleration times, allowing a simple position control system to be constructed without a Positioner or Host Controller.

The acceleration and deceleration times are set separately, and the setting range is 0 to 10 s for each.

Pulse Smoothing Function (Position Control)

Even high-frequency commands can be executed smoothly by including acceleration/deceleration in the command pulses. The same setting is used for both the acceleration and deceleration times, and the setting range is 0 to 64 ms.

 Reverse Mode

Forward/Reverse commands can be switched in the parameters, without changing the wiring to the motor or encoder.

 Brake Interlock Output

Outputs a timing signal interlocked with the motor's ON/OFF status and rotational speed. The holding brake of a motor with a brake can be operated reliably.

 Overtravel Sequence

An overtravel sequence compatible with the system can be selected. There are three deceleration methods available: dynamic brake deceleration, free-run deceleration, and emergency-stop torque deceleration (parameter setting).

 Feed-forward and Bias Functions (Position Control)

These functions reduce the position control time.

Feed-forward Function

Reduces the position control time by reducing the number of pulses accumulated in the deviation counter.

Bias Function

Reduces the position control time by adding the bias revolutions to the speed control when the deviation counter value exceeds the position completion range.

 Computer Monitor Software (HA/LA/V/W Models)

The special Servo Driver Communications Software allows parameter setting, speed and current monitoring, I/O monitoring, auto-tuning, and jog operations to be performed from a personal computer. It is also possible to perform multiple-axis communications that set the parameters and monitor the operation of several drivers. Refer to the *Computer Monitor Software Instruction Manual (I513)* for OMNUC U-series Servo Drivers for more details.

1-2 System Configuration

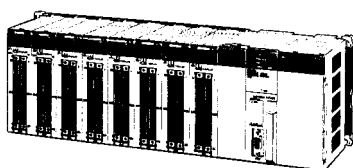

SYSMAC CS1/C/CV
Programmable Controller

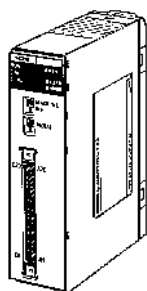

C200HW-NC113
C200HW-NC213
C200HW-NC413
C200H-NC112
C200H-NC211
C500-NC113
C500-NC211
Position Control Unit

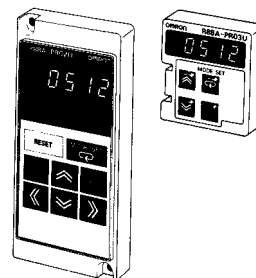

Parameter Units

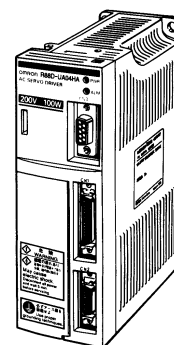

OMNUC U-series
AC Servo Driver

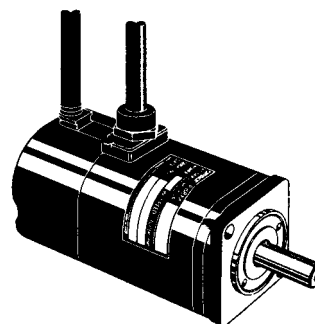

OMNUC U-series
AC Servomotor

1-3 Servo Driver Nomenclature

□ Front View

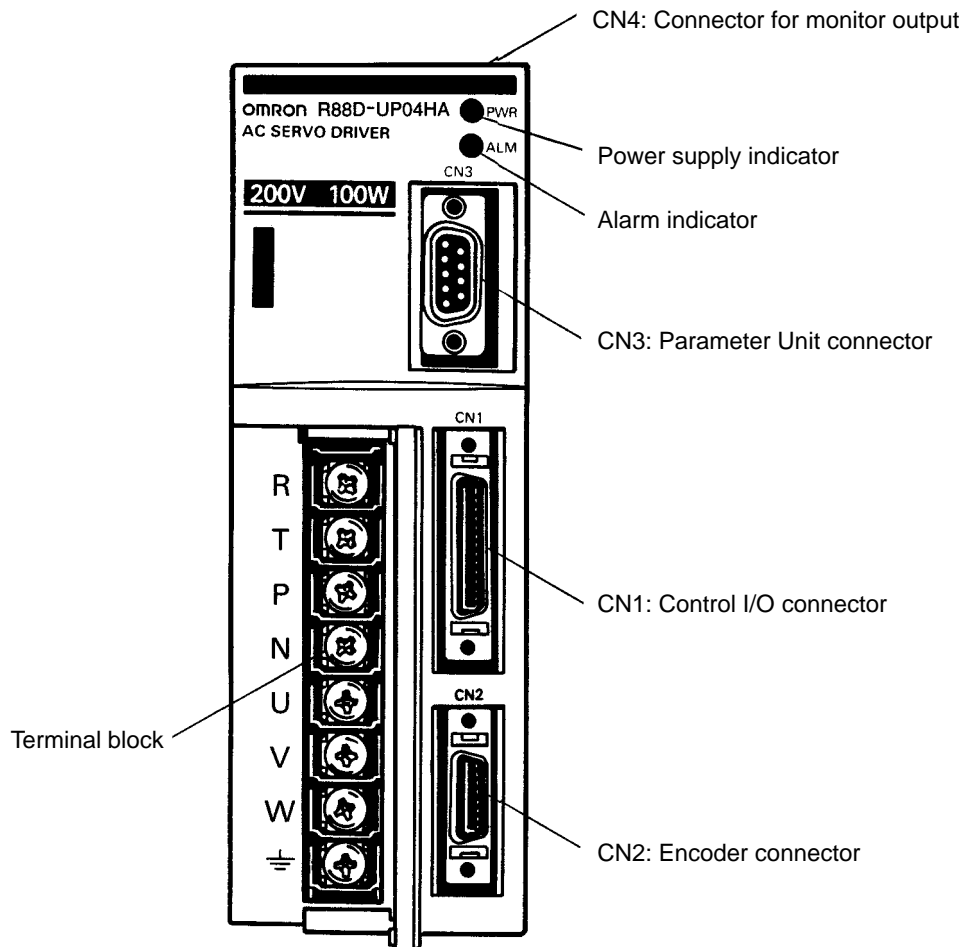

1-4 Applicable Standards and Models

1-4-1 UL/cUL Standards

Applicable Standards

Standard	Product	Applicable Standard	File No.	Remarks
UL	AC Servo Driver	UL508C	E179149	Power conversion equipment
	AC Servomotor	UL1004	E179189	Electric motors
cUL	AC Servo Driver	cUL C22.2 No. 14	E179149	Industrial control equipment
	AC Servomotor	cUL C22.2 No.100	E179189	Motor and generators

Applicable Models

Power supply	AC Servo Drivers	AC Servomotors
		With incremental encoder
200 VAC	R88D-UP HA (See note 1.)	R88M-U 30HA- (See note 2.) (See note 3.)
100 VAC	R88D-UP LA (See note 1.)	R88M-U 30LA- (See notes 2.) (See note 3.)

Note 1. Maximum output current: for example, “04” means approx. 4 A.

Note 2. Motor capacity: for example, “100” means 100 W.

Note 3. Optional specifications

None: Straight shaft without keys and without brake

B: Straight shaft without keys and with brake

S1: Straight shaft with keys and without brake

BS1: Straight shaft with keys and with brake

Note 4. UL/cUL Standards apply to models manufactured after May 1998.

1-4-2 EC Directives

Applicable Standards

EC Directive	Product	Directive	Remarks
Low voltage	AC Servo Driver	EN61010-1	Safety requirements for electrical equipment for measurement, control, and laboratory use.
	AC Servomotor	IEC34-1, -5, -8, -9	Rotating electrical machines.
EMC	AC Servo Driver AC Servomotor	EN55011 class A group 1	Limits and methods of measurement of radio disturbance characteristics of industrial, scientific, and medical (ISM) radio-frequency equipment.
		EN50082-2	Electromagnetic compatibility generic immunity standard, Part 2 Industrial environment.

Note Installation under the conditions specified in 2-3-3 *Wiring Products Conforming to EMC Directives* is required to conform to EMC Directives.

Applicable Models

Power supply	AC Servo Drivers	AC Servomotors	
		With incremental encoder	
200 VAC	R88D-UP V	R88M-U 30VA-	(See note.)
100 VAC	R88D-UP W	R88M-U 30WA-	(See note.)

Note Optional specifications (shaft profile: straight shaft with keys)

S1: Straight shaft with keys and without brake

BS1: Straight shaft with keys and with brake

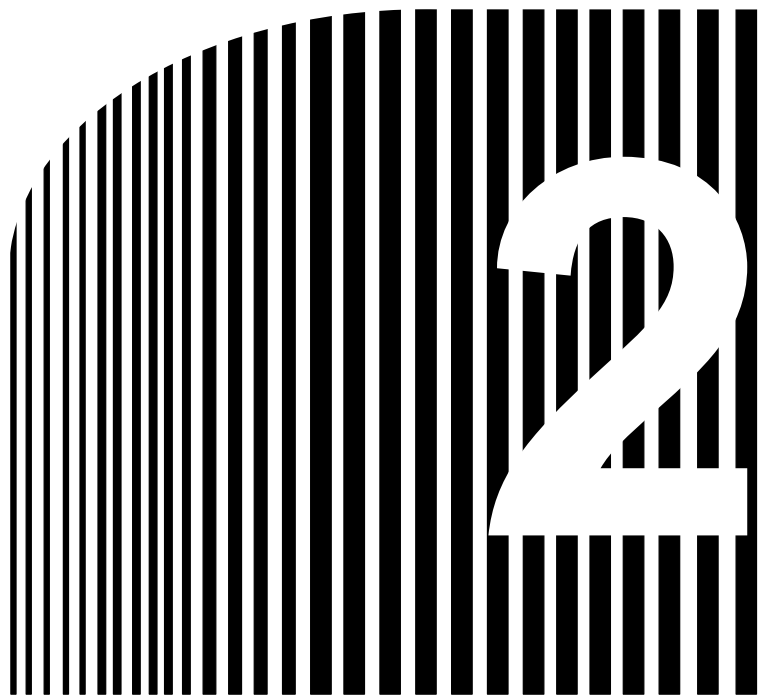















Chapter 2

• System Design and Installation •

- 2-1 Installation
- 2-2 Wiring Products Conforming to UL/cUL
and Wiring Products Not Conforming to Any
Standards
- 2-3 Wiring Products Conforming to EC Directives

Installation and Wiring Precautions

-  **Caution** Do not step on or place a heavy object on the product. Doing so may result in injury.
-  **Caution** Do not cover the inlet or outlet ports and prevent any foreign objects from entering the product. Doing so may result in fire.
-  **Caution** Be sure to install the product in the correct direction. Not doing so may result in malfunction.
-  **Caution** Provide the specified clearances between the Servo Driver and the control panel or with other devices. Not doing so may result in fire or malfunction.
-  **Caution** Do not apply any strong impact. Doing so may result in malfunction.
-  **Caution** Be sure to wire correctly and securely. Not doing so may result in motor runaway, injury, or malfunction.
-  **Caution** Be sure that all the mounting screws, terminal screws, and cable connector screws are tightened to the torque specified in the relevant manuals. Incorrect tightening torque may result in malfunction.
-  **Caution** Use crimp terminals for wiring. Do not connect bare stranded wires directly to terminals. Connection of bare stranded wires may result in burning.
-  **Caution** Always use the power supply voltage specified in the User's Manual. An incorrect voltage may result in malfunction or burning.
-  **Caution** Take appropriate measures to ensure that the specified power with the rated voltage and frequency is supplied. Be particularly careful in places where the power supply is unstable. An incorrect power supply may result in malfunction.
-  **Caution** Install external breakers and take other safety measures against short-circuiting in external wiring. Insufficient safety measures against short-circuiting may result in burning.
-  **Caution** Provide an appropriate stopping device on the machine side to secure safety. (A holding brake is not a stopping device for securing safety.) Not doing so may result in injury.
-  **Caution** Provide an external emergency stopping device that allows an instantaneous stop of operation and power interruption. Not doing so may result in injury.
-  **Caution** Take appropriate and sufficient countermeasures when installing systems in the following locations:
 - Locations subject to static electricity or other forms of noise.
 - Locations subject to strong electromagnetic fields and magnetic fields.
 - Locations subject to possible exposure to radioactivity.
 - Locations close to power supplies.

2-1 Installation

2-1-1 External Dimensions (Unit: mm)

□ **AC Servo Drivers Conforming to UL/cUL Standards and AC Servomotors Not Conforming to Any Standards**

**R88D-UP02H(A)/UP03H(A)/UP04H(A)/UP08H(A) (200 VAC, 30 to 200 W)
R88D-UP03L(A)/UP04L(A)/UP10L(A) (100 VAC, 30 to 100 W)**

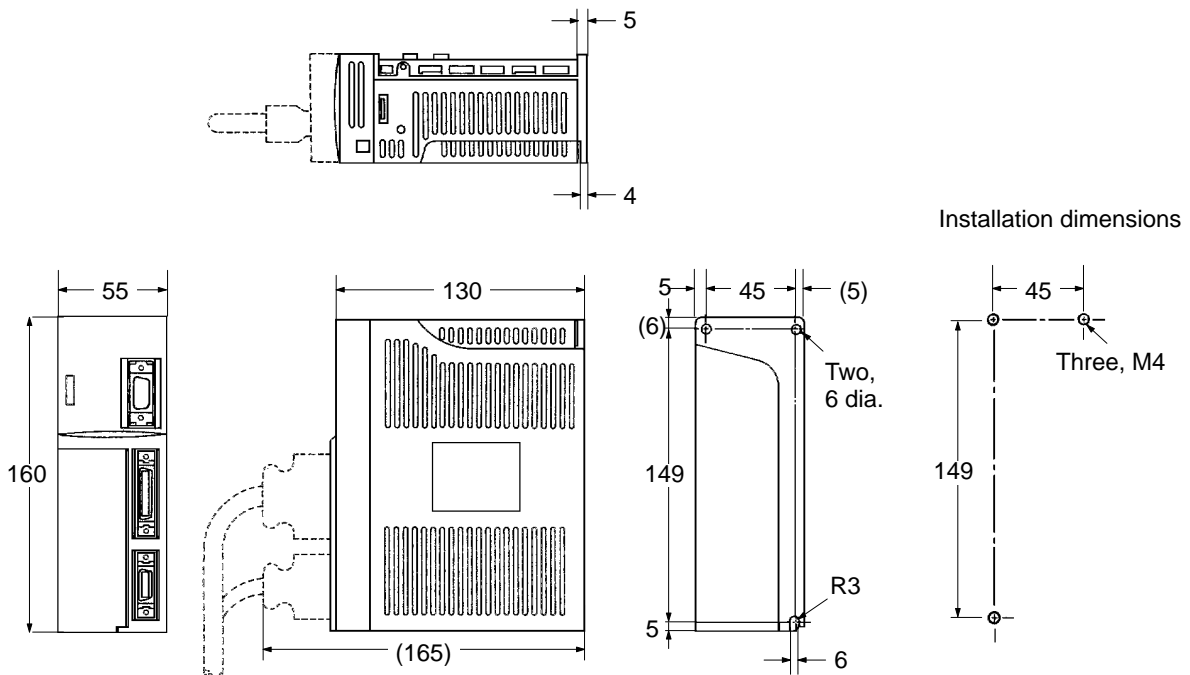

R88D-UP12H(A) (200 VAC, 400 W) and R88D-UP12L(A) (100 VAC, 200 W)

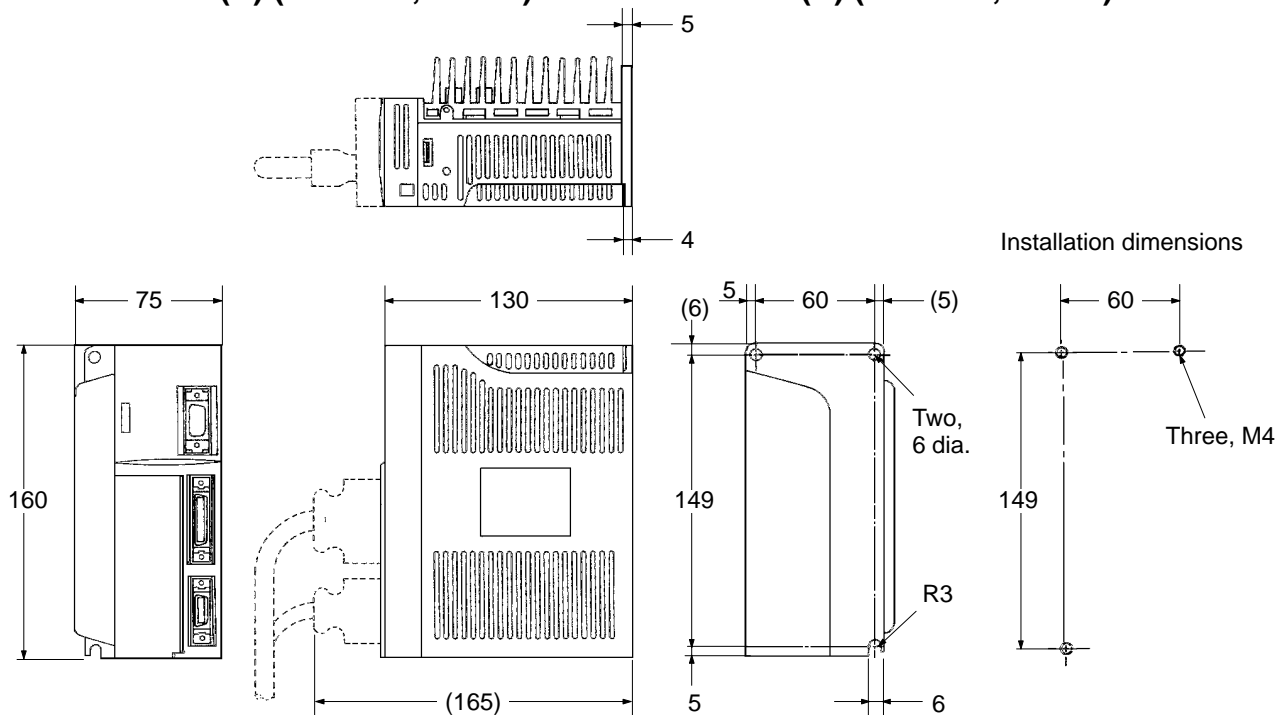

□ AC Servo Drivers Conforming to UL/cUL Standards and AC Servomotors Not Conforming to Any Standards (Contd.)

R88D-UP20H(A) (200 VAC, 750 W) and R88D-UP15LA (100 VAC, 300 W)

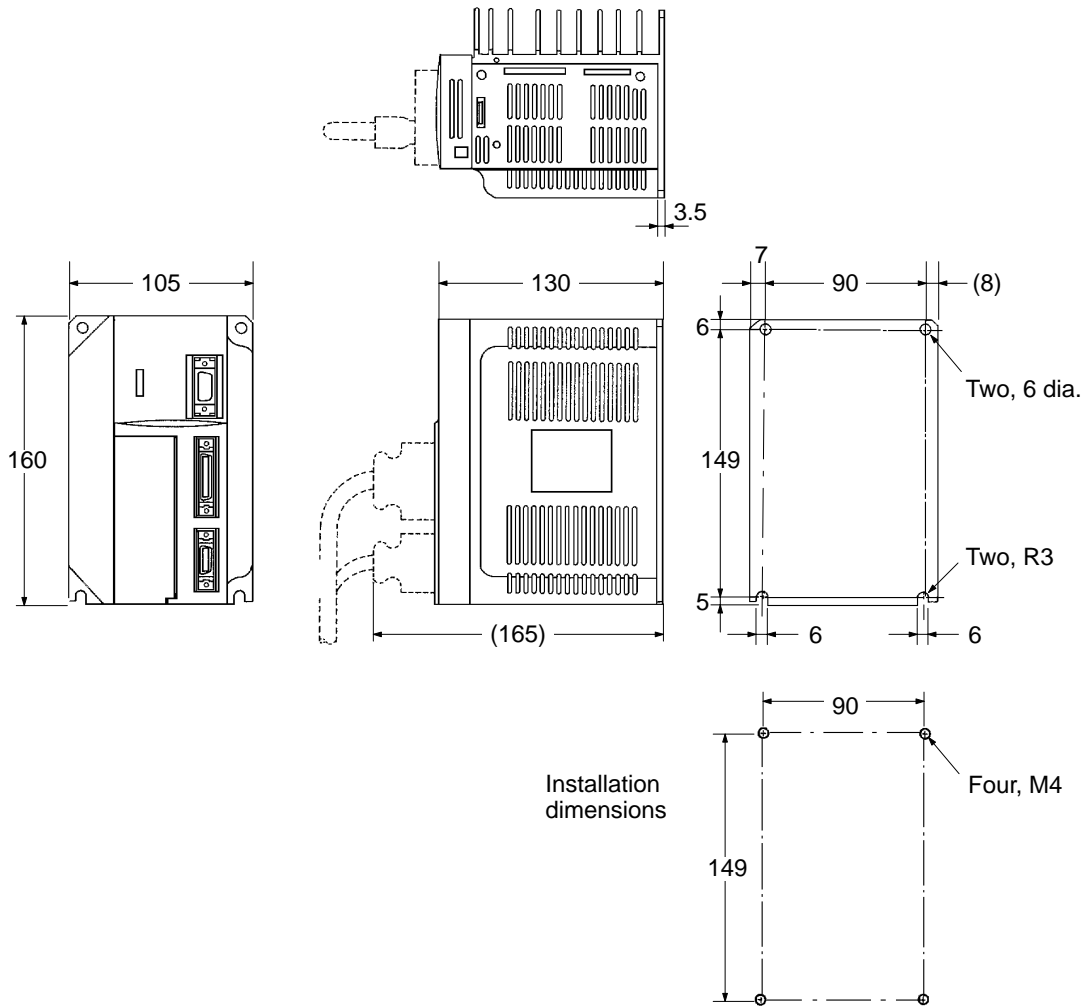

□ AC Servo Drivers Conforming to EC Directives

**R88D-UP02V/UP03V/UP04V/UP08V (200 VAC, 30 to 200 W)
R88D-UP03W/UP04W/UP10W (100 VAC, 30 to 100 W)**

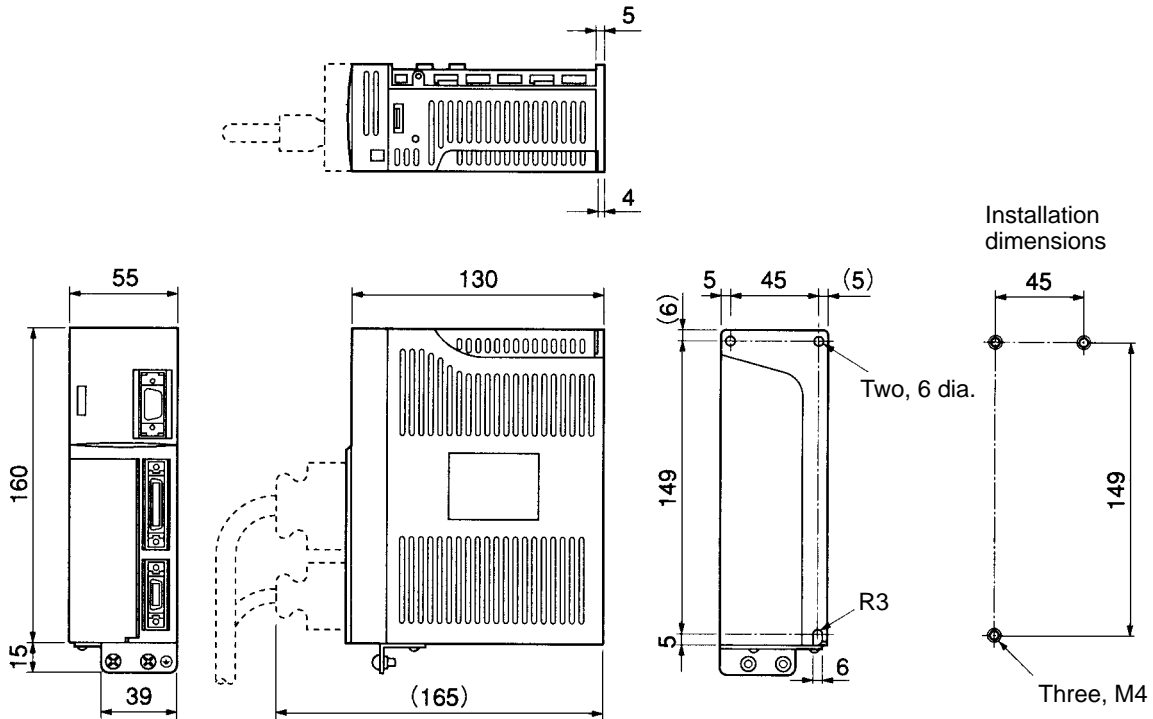

**R88D-UP12V (200 VAC, 400 W)
R88D-UP12W (100 VAC, 200 W)**

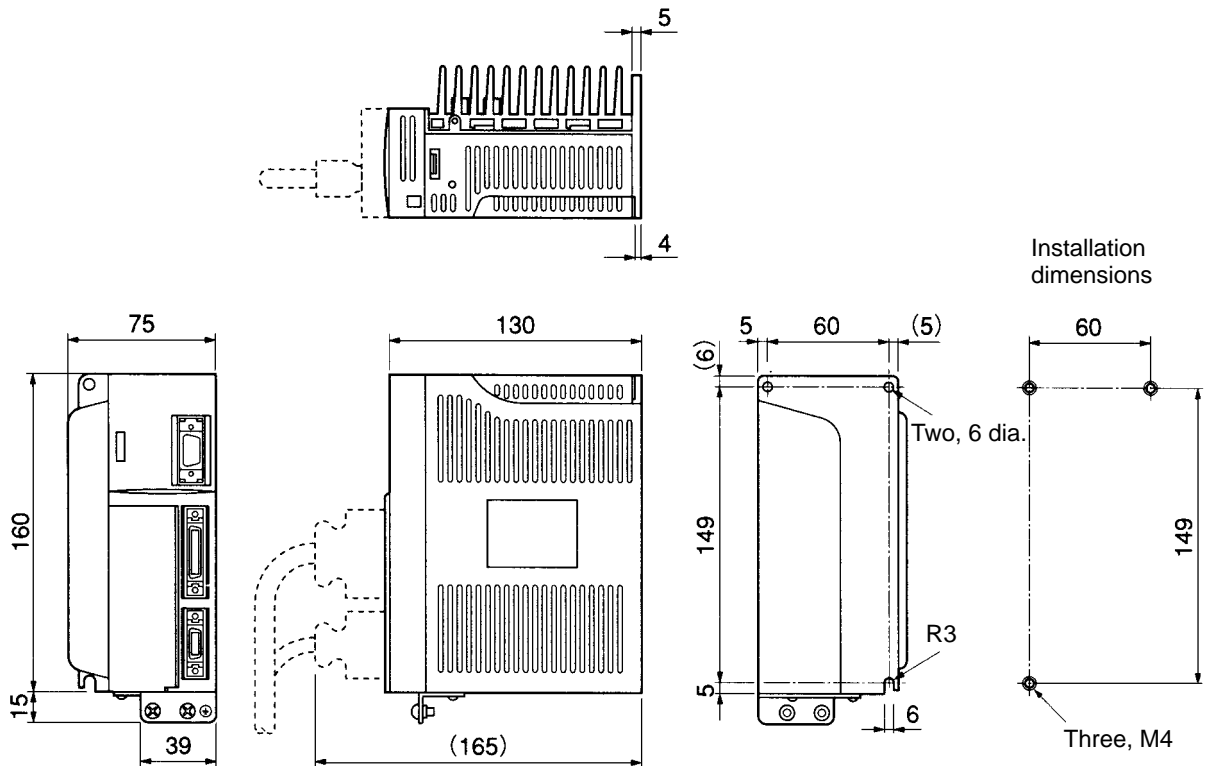

□ AC Servo Drivers Conforming to EC Directives (Contd.)

R88D-UP20V (200 VAC, 750 W)

R88D-UP15W (100 VAC, 300 W)

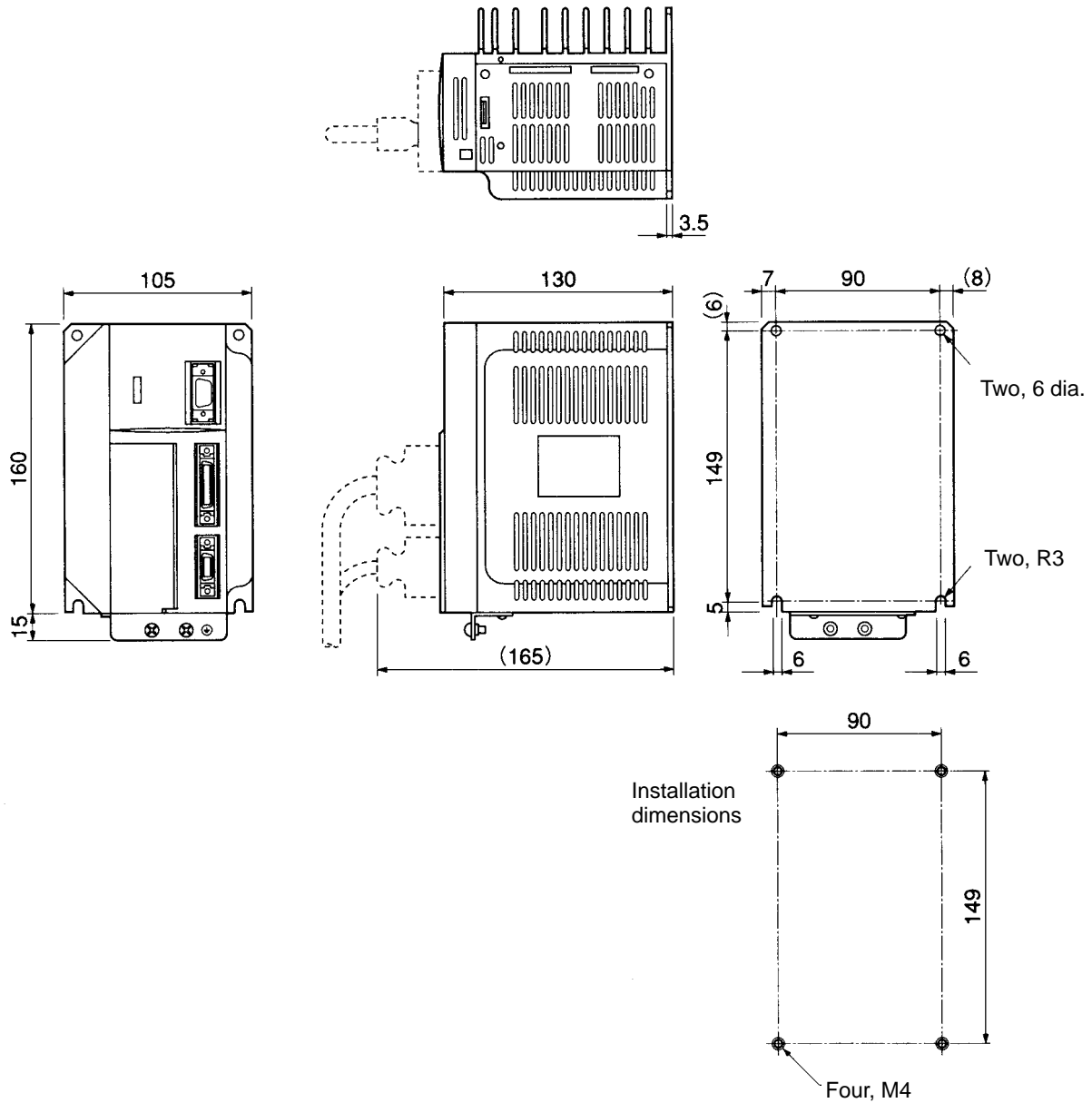

Regeneration Unit

R88A-RG08UA

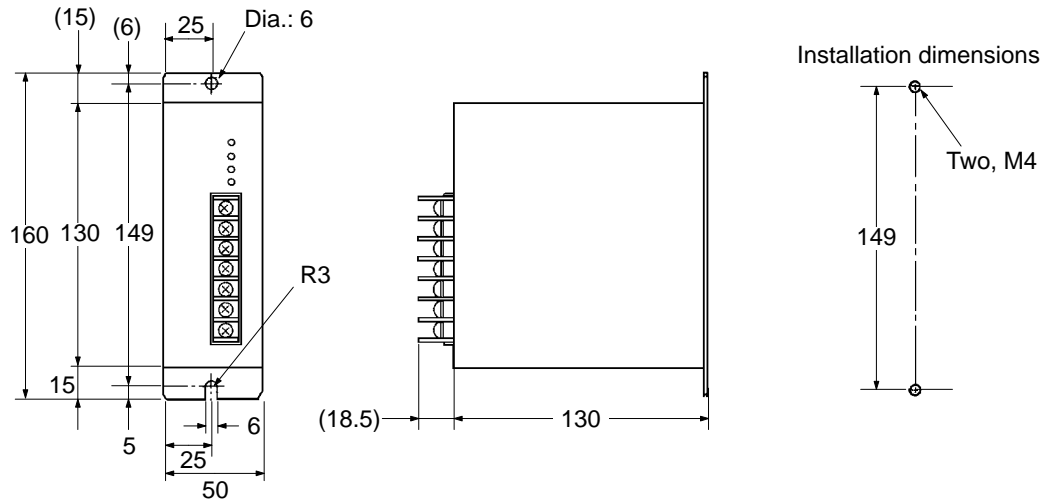

Parameter Units

R88A-PR02U

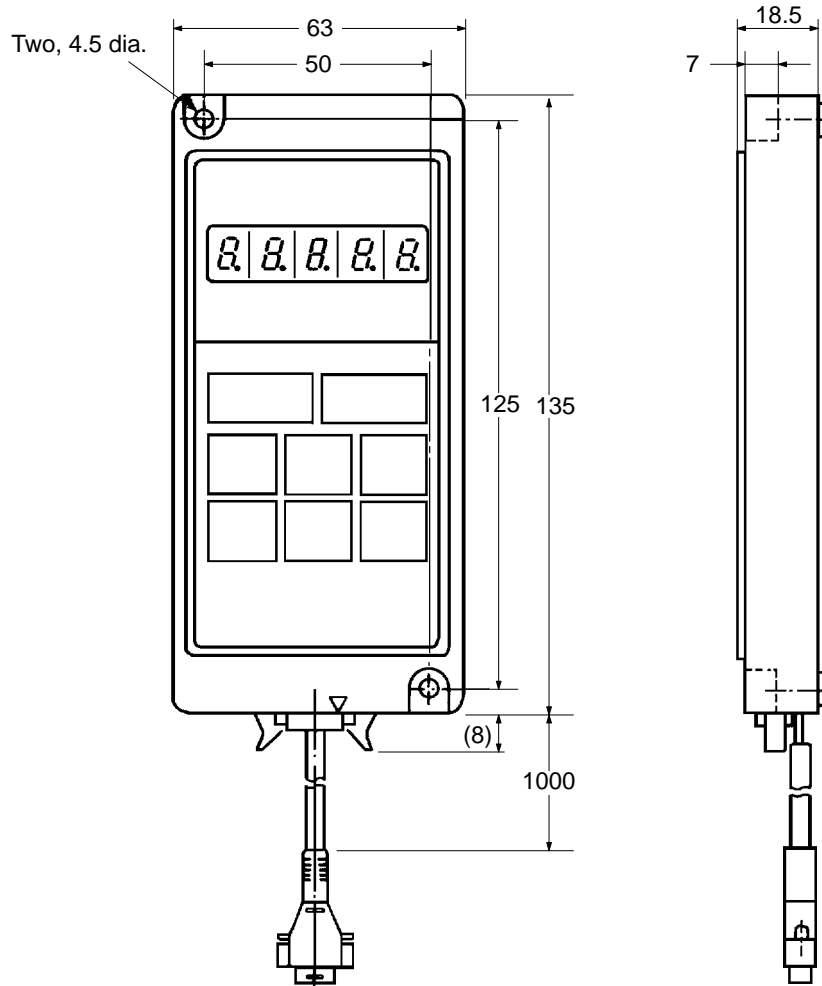

R88A-PR03U

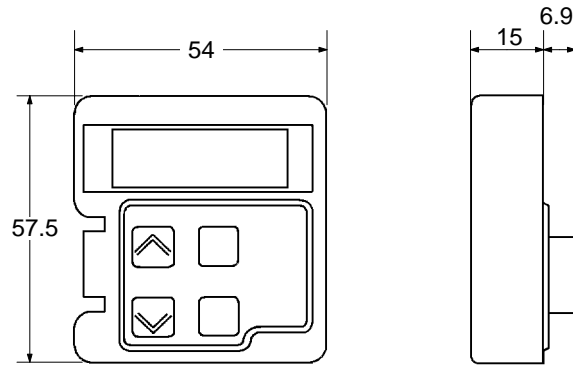

□ AC Servomotors Conforming to UL/cUL Standards and AC Servomotors Not Conforming to Any Standards

30-W/50-W/100-W Standard Models:

R88M-U03030HA, R88M-U05030HA, R88M-U10030HA

R88M-U03030LA, R88M-U05030LA, R88M-U10030LA

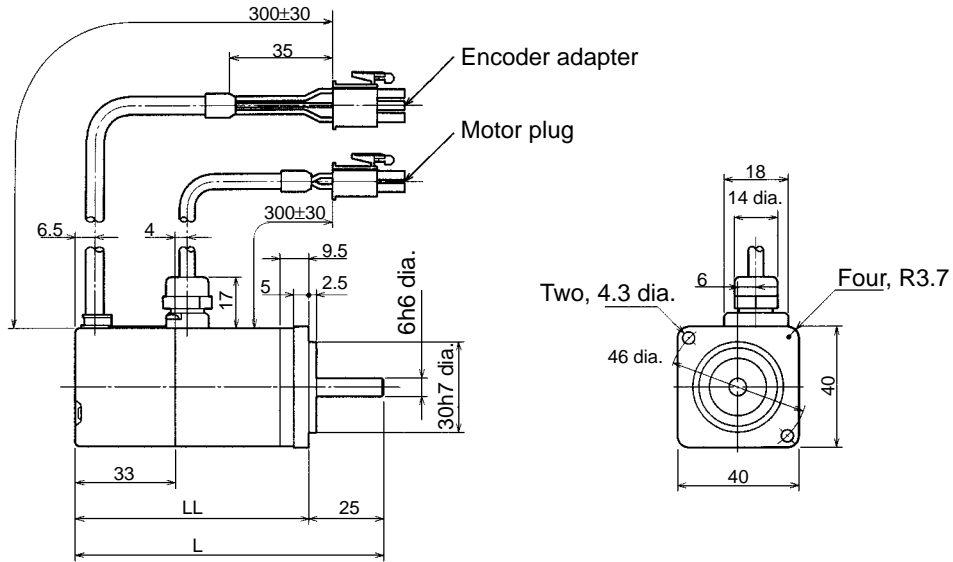

30-W/50-W/100-W Models with Brake:

R88M-U03030HA-B, R88M-U05030HA-B, R88M-U10030HA-B

R88M-U03030LA-B, R88M-U05030LA-B, R88M-U10030LA-B

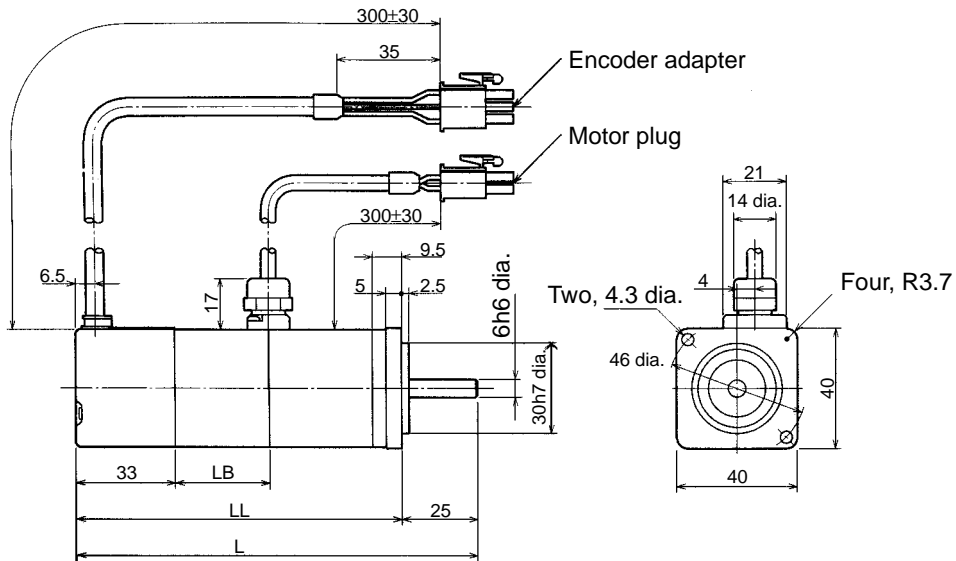

Standard Models			
Model	L	LL	S
R88M-U03030HA R88M-U03030LA	94.5	69.5	6
R88M-U05030HA R88M-U05030LA	102.0	77.0	6
R88M-U10030HA R88M-U10030LA	119.5	94.5	8

Models with Brake				
Model	L	LL	LB	S
R88M-U03030HA-B R88M-U03030LA-B	126	101	31.5	6
R88M-U05030HA-B R88M-U05030LA-B	133.5	108.5	31.5	6
R88M-U10030HA-B R88M-U10030LA-B	160	135	40.5	8

□ AC Servomotors Conforming to UL/cUL Standards and AC Servomotors Not Conforming to Any Standards (Contd.)

200-W/300-W/400-W Standard Models:
R88M-U20030HA, R88M-U40030HA
R88M-U20030LA, R88M-U30030LA

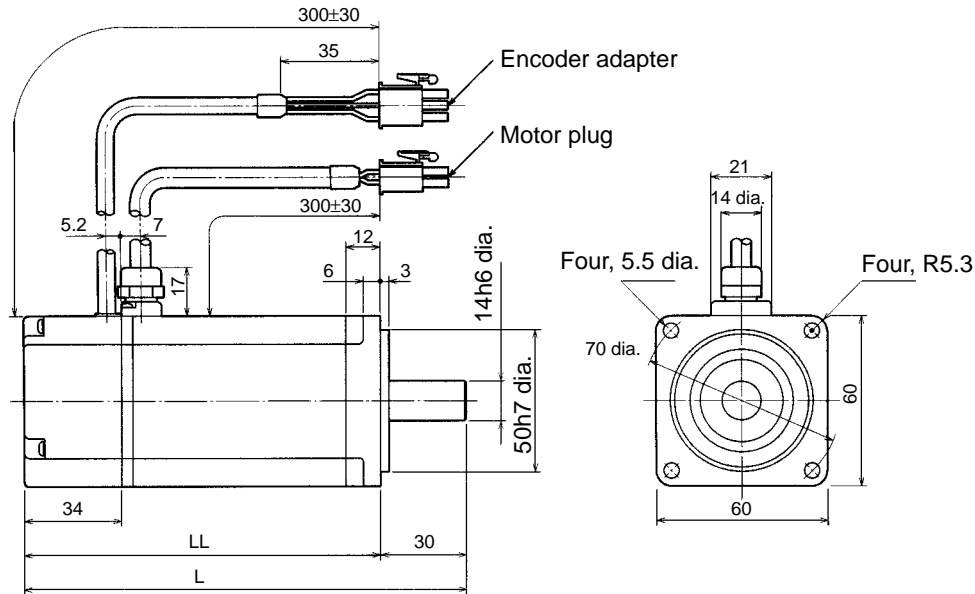

200-W/300-W/400-W Models with Brake:
R88M-U20030HA-B, R88M-U40030HA-B
R88M-U20030LA-B, R88M-U30030LA-B

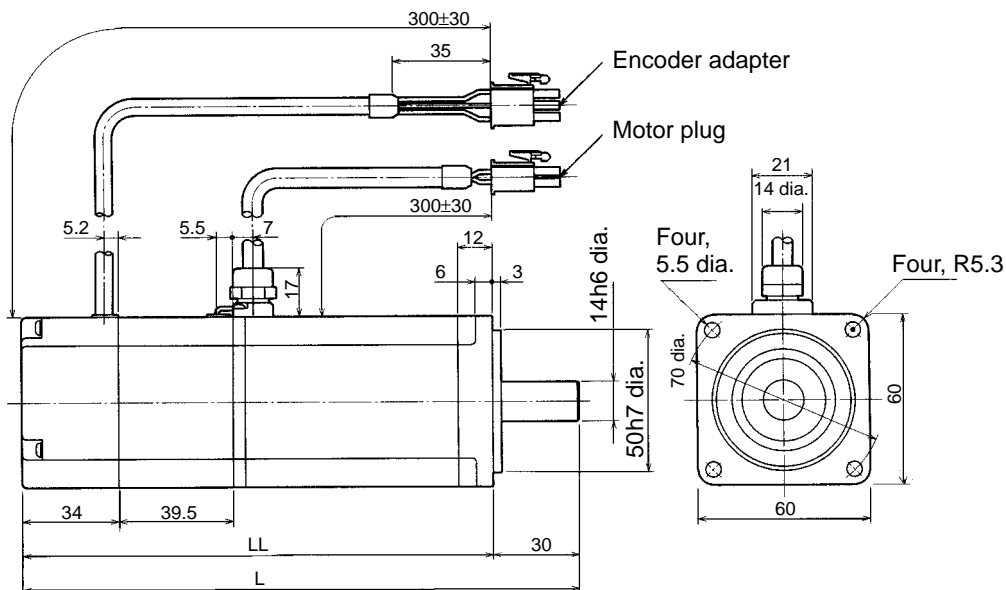

Standard Models		
Model	L	LL
R88M-U20030HA R88M-U20030LA	126.5	96.5
R88M-U40030HA R88M-U30030LA	154.5	124.5

Models with Brake		
Model	L	LL
R88M-U20030HA-B R88M-U20030LA-B	166	136
R88M-U40030HA-B R88M-U30030LA-B	194	164

□ AC Servomotors Conforming to UL/cUL Standards and AC Servomotors Not Conforming to Any Standards (Contd.)

750-W Standard Models: R88M-U75030HA

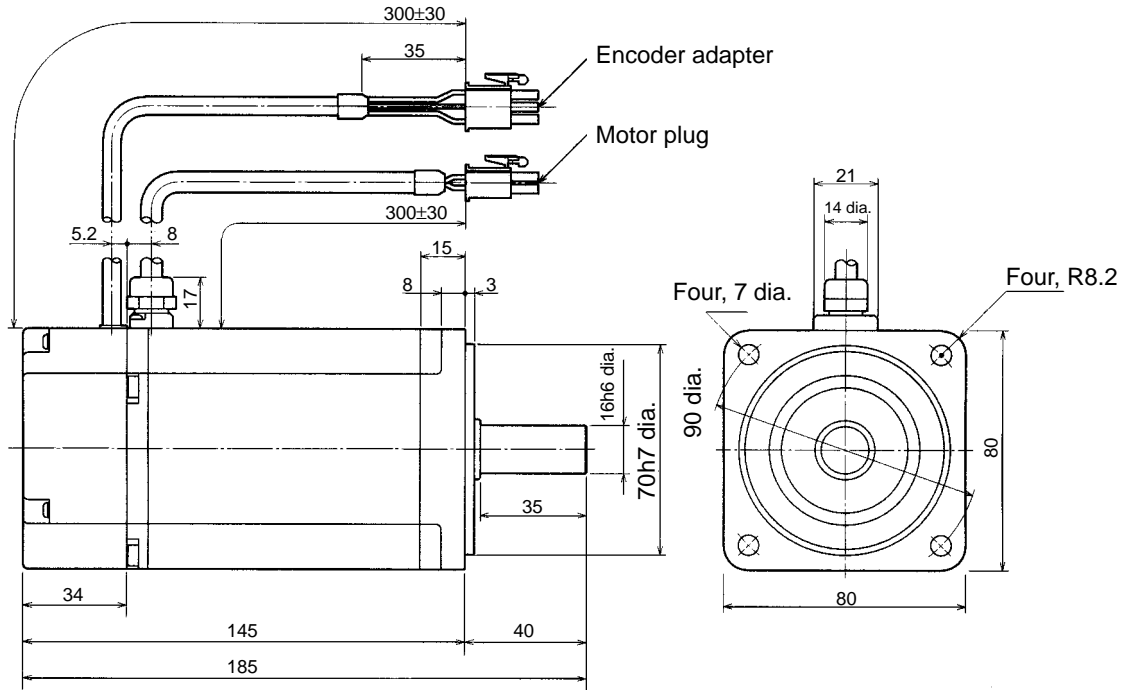

750-W Models with Brake: R88M-U75030HA-B

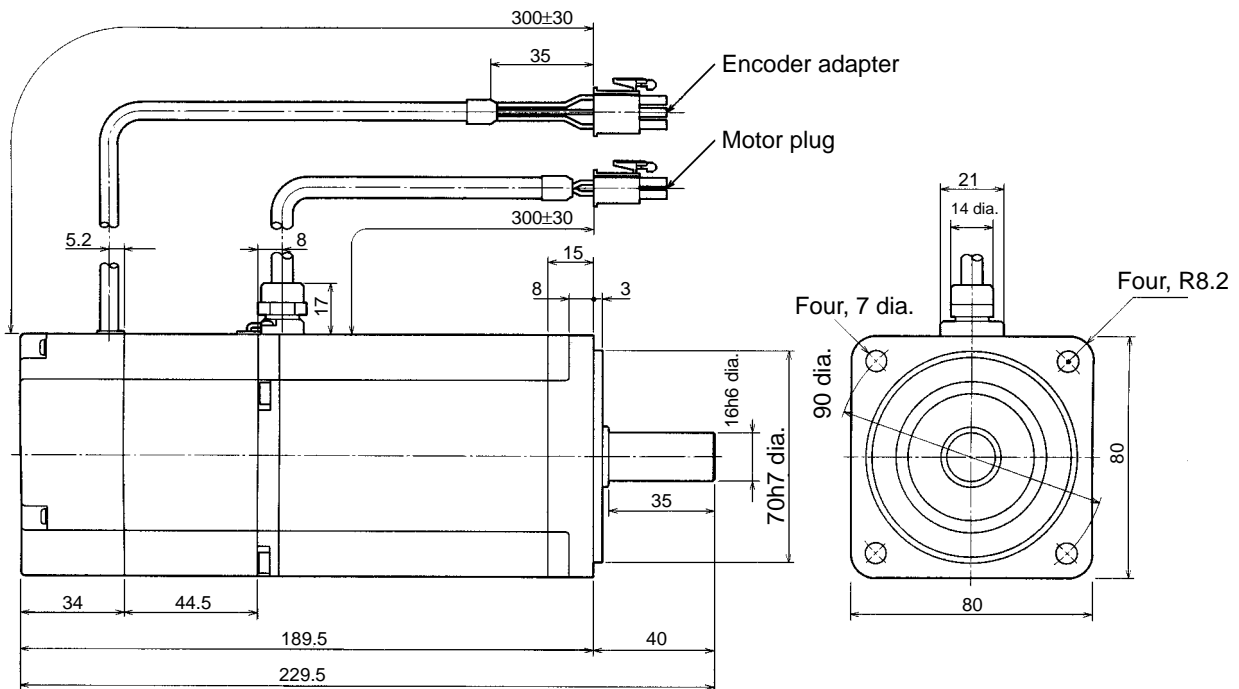

□ AC Servomotors Conforming to EC Directives

30-W/50-W/100-W Standard Models:

R88M-U03030VA-S1, R88M-U05030VA-S1, R88M-U10030VA-S1

R88M-U03030WA-S1, R88M-U05030WA-S1, R88M-U10030WA-S1

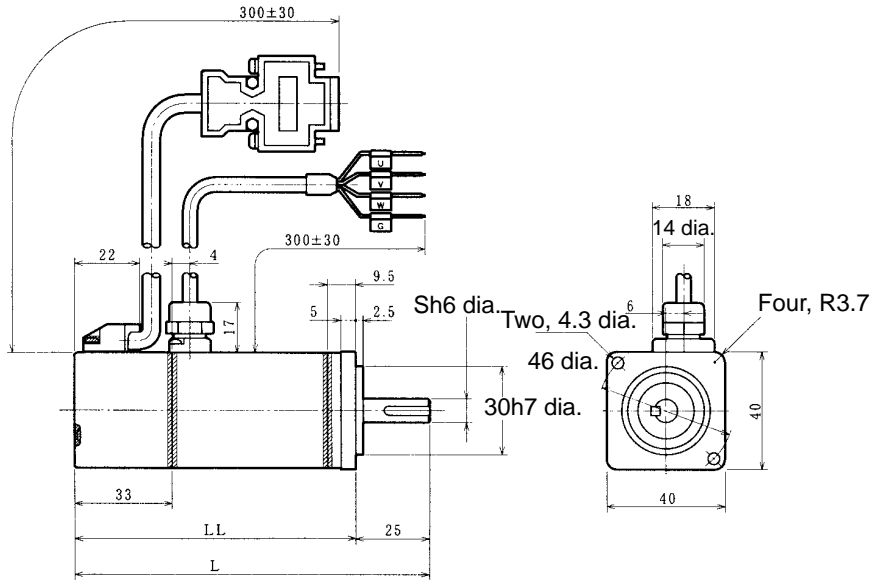

30-W/50-W/100-W Models with Brake:

R88M-U03030VA-BS1, R88M-U05030VA-BS1, R88M-U10030VA-BS1

R88M-U03030WA-BS1, R88M-U05030WA-BS1, R88M-U10030WA-BS1

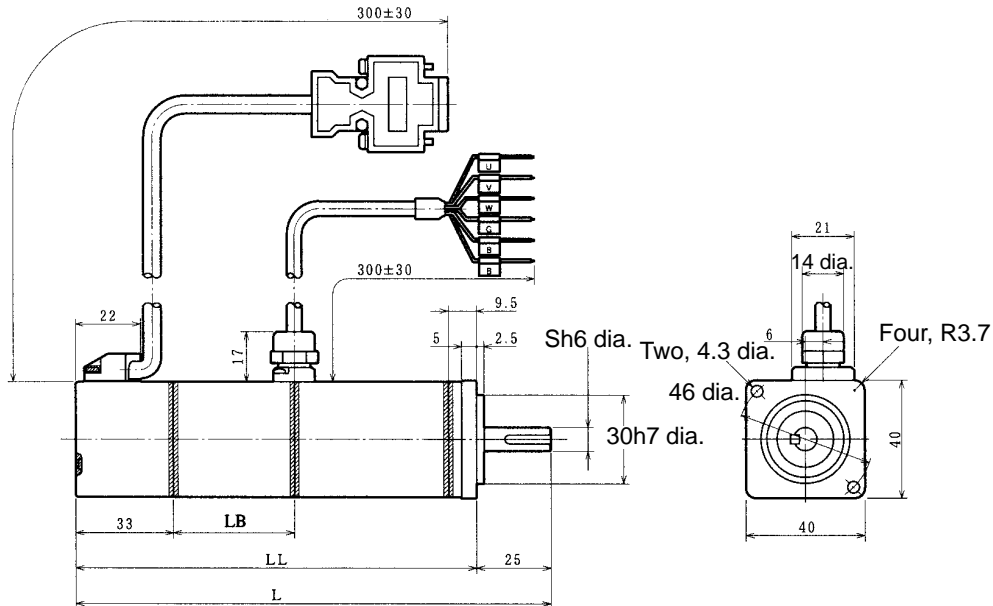

Standard Models			
Model	L	LL	S
R88M-U03030VA-S1 R88M-U03030WA-S1	94.5	69.5	6
R88M-U05030VA-S1 R88M-U05030WA-S1	102.0	77.0	6
R88M-U10030VA-S1 R88M-U10030WA-S1	119.5	94.5	8

Models with Brake				
Model	L	LL	LB	S
R88M-U03030VA-BS1 R88M-U03030WA-BS1	126	101	31.5	6
R88M-U05030VA-BS1 R88M-U05030WA-BS1	133.5	108.5	31.5	6
R88M-U10030VA-BS1 R88M-U10030WA-BS1	160	135	40.5	8

□ **AC Servomotors Conforming to EC Directives (Contd.)**

**200-W/300-W/400-W Standard Models: R88M-U20030VA-S1, R88M-U40030VA-S1
R88M-U20030WA-S1, R88M-U30030WA-S1**

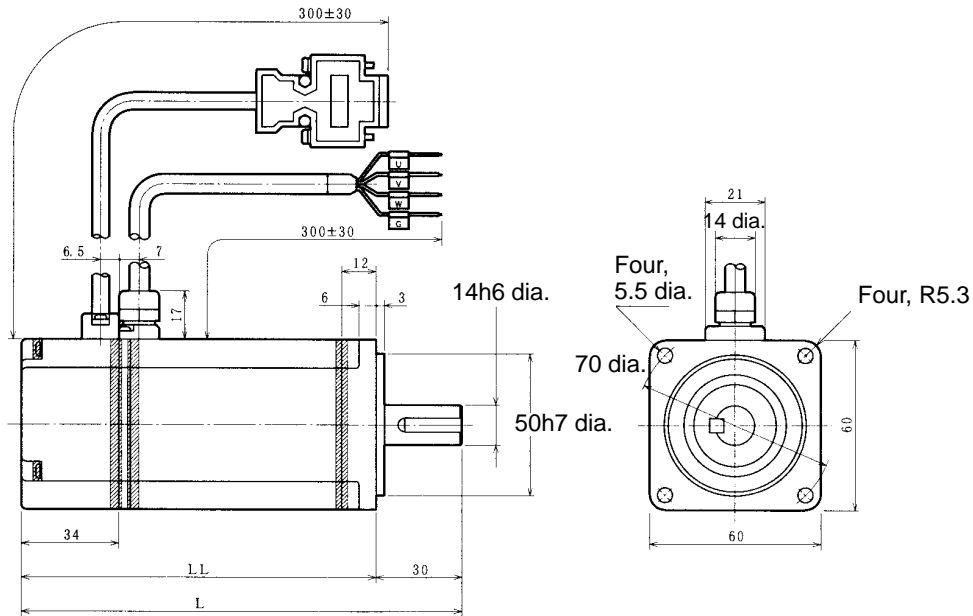

200-W/300-W/400-W Models with Brake: R88M-U20030VA-BS1, R88M-U40030VA-BS1, R88M-U20030WA-BS1, R88M-U30030WA-BS1

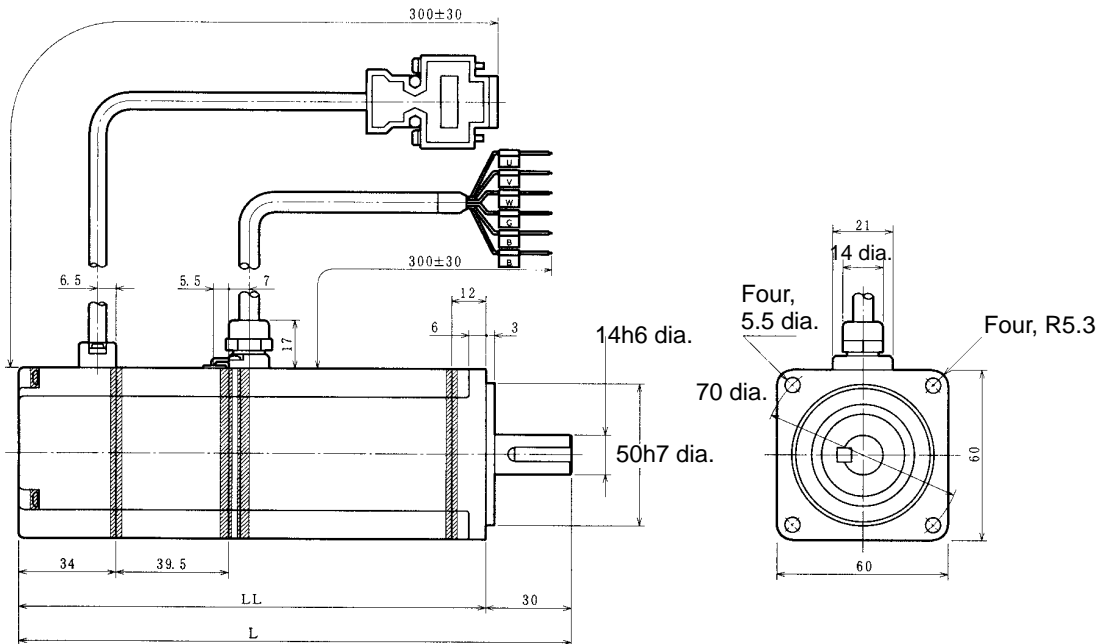

Standard Models	Standard Models	
Model	L	LL
R88M-U20030VA-S1 R88M-U20030WA-S1	126.5	96.5
R88M-U40030VA-S1 R88M-U30030-WA-S1	154.5	124.5

Models with Brake		
Model	L	LL
R88M-U20030VA-BS1 R88M-U20030WA-BS1	166	136
R88M-U40030VA-BS1 R88M-U30030WA-BS1	194	164

□ **AC Servomotors Conforming to EC Directives (Contd.)**

750-W Standard Models: R88M-U75030VA-S1

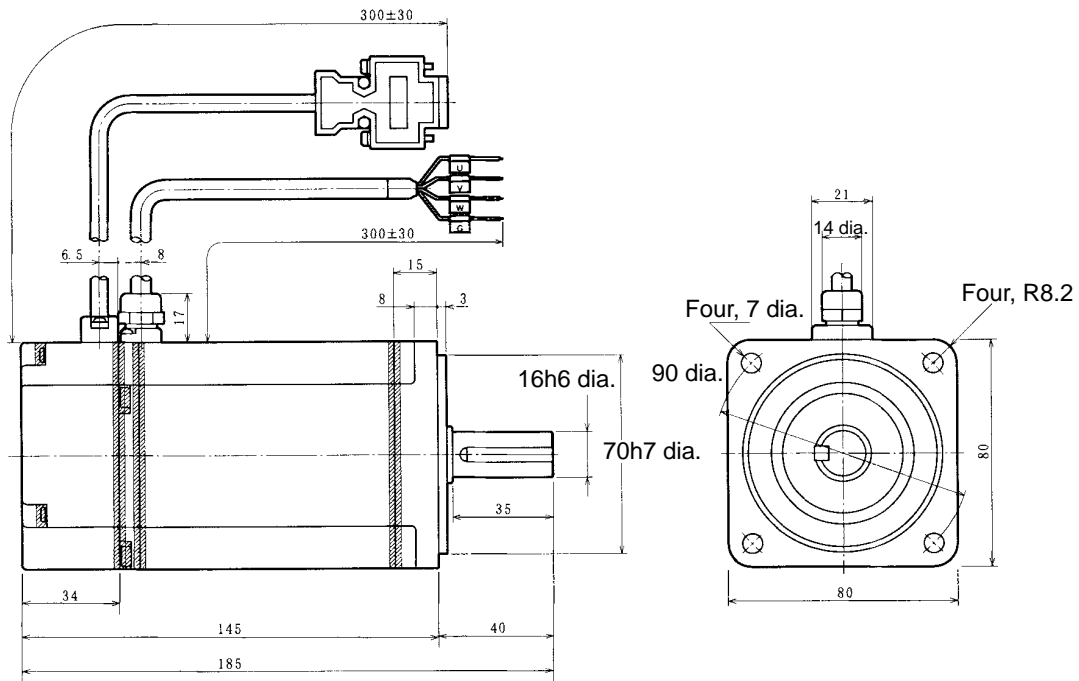

750-W Models with Brake: R88M-U75030VA-BS1

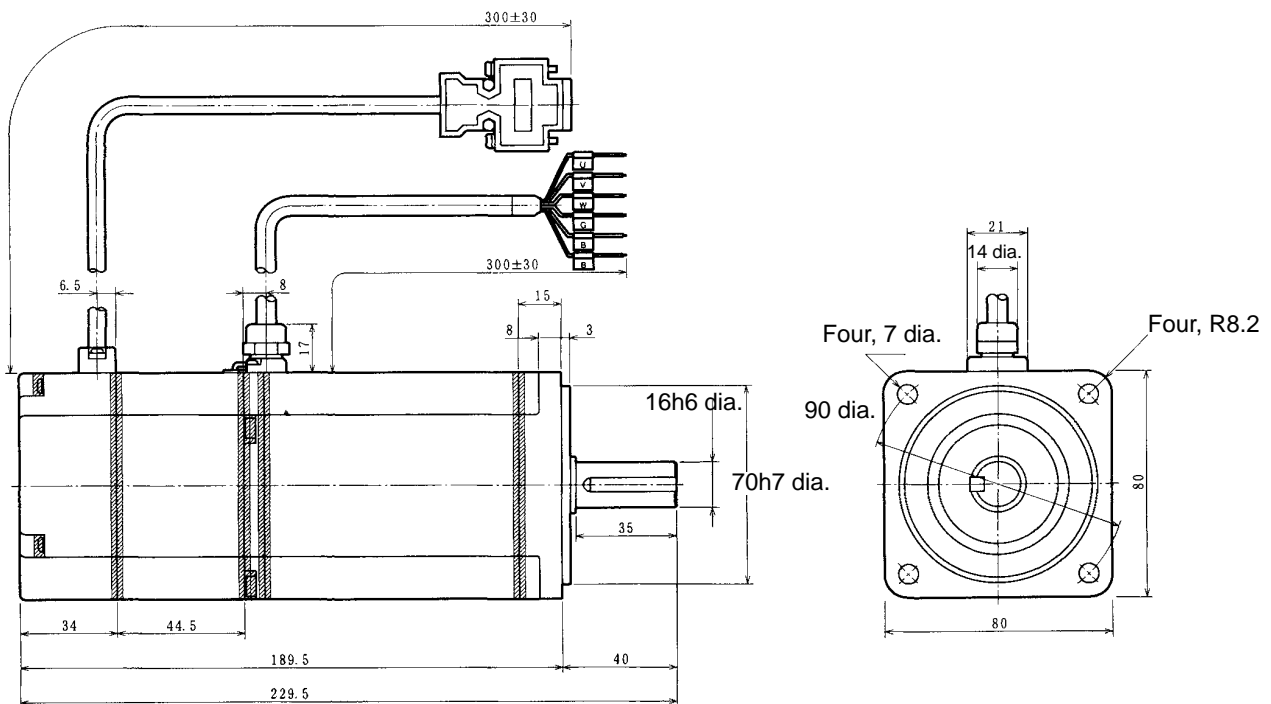

□ Shaft Dimensions of Motors With Keys

Standard U-series AC Servomotors do not have keys on the shafts. The dimensions of motors with keys (produced on order) are shown below. Motors with keys are indicated by adding “-S1” to the end of the model number. Key slots are based on JIS B1301-1976.

30-W/50-W Models

Without Brake: R88M-U03030 -S1, R88M-U05030 -S1

With Brake: R88M-U03030 -BS1, R88M-U05030 -BS1

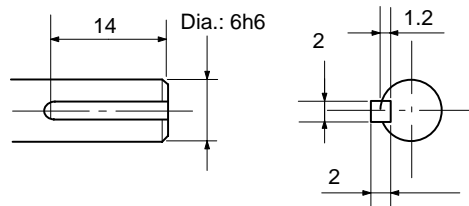

100-W Models

Without Brake: R88M-U10030 -S1

With Brake: R88M-U10030 -BS1

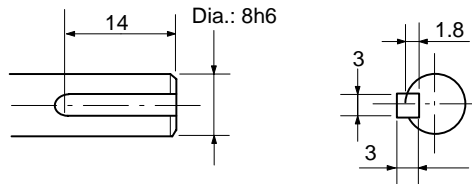

200-W/300-W/400-W Models

Without Brake: R88M-U20030 -S1, R88M-U40030 -S1, R88M-U30030 -S1

With Brake: R88M-U20030 -BS1, R88M-U40030 -BS1, R88M-U30030 -BS1,

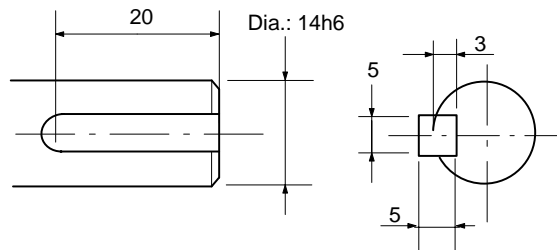

750-W Models

Without Brake: R88M-U75030 -S1,

With Brake: R88M-U75030 -BS1

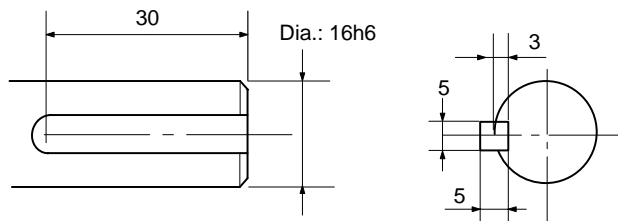

2-1-2 Installation Conditions

AC Servo Drivers

Space Around Drivers

- Install Servo Drivers according to the dimensions shown in the following illustration to ensure proper heat dispersion and convection inside the panel. Also install a fan for circulation if Servo Drivers are installed side by side to prevent uneven temperatures from developing inside the panel.
- Mount the Servo Drivers vertically (so that the model number and writing can be read).

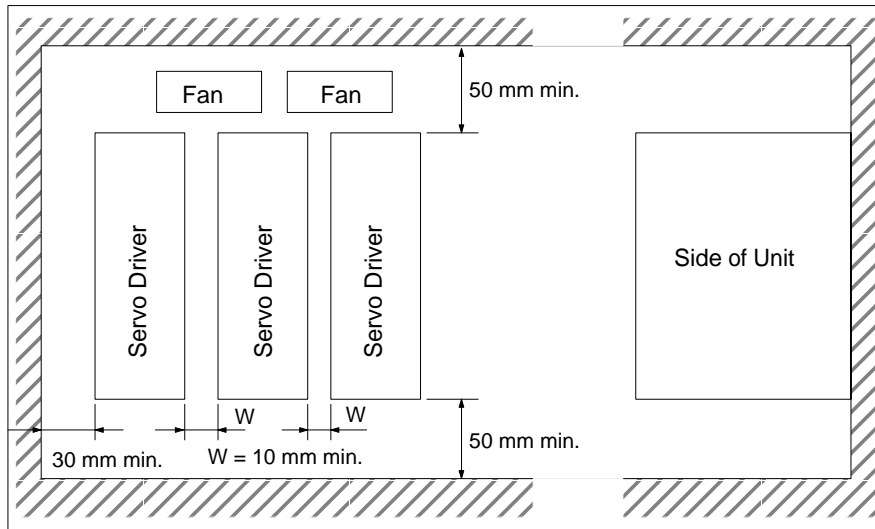

Operating Environment

Be sure that the environment in which Servo Drivers are operated meets the following conditions.

- Ambient operating temperature: 0°C to +55°C
- Ambient operating humidity: 35% to 85% (RH, with no condensation)
- Atmosphere: No corrosive gases.

Ambient Temperature

- Servo Drivers should be operated in environments in which there is minimal temperature rise to maintain a high level of reliability.
- Temperature rise in any Unit installed in a closed space, such as a control box, will cause the ambient temperature to rise inside the entire closed space. Use a fan or a air conditioner to prevent the ambient temperature of the Servo Driver from exceeding 55°C.
- Unit surface temperatures may rise to as much as 30°C above the ambient temperature. Use heat-resistant materials for wiring, and keep separate any devices or wiring that are sensitive to heat.
- The service life of a Servo Driver is largely determined by the temperature around the internal electrolytic capacitors. The service life of an electrolytic capacitor is affected by a drop in electrolytic volume and an increase in internal resistance, which can result in overvoltage alarms, malfunctioning due to noise, and damage to individual elements. If a Servo Driver is always operated at the maximum ambient temperature of 55°C, then a service life of approximately 50,000 hours can be expected. A drop of 10°C in the ambient temperature will double the expected service life.

Keeping Foreign Objects Out of Units

- Place a cover over the Units or take other preventative measures to prevent foreign objects, such as drill filings, from getting into the Units during installation. Be sure to remove the cover after installation is complete. If the cover is left on during operation, heat buildup may damage the Units.
- Take measures during installation and operation to prevent foreign objects such as metal particles, oil, machining oil, dust, or water from getting inside of Servo Drivers.

□ AC Servomotors

Operating Environment

Be sure that the environment in which the Servomotor is operated meets the following conditions.

- Ambient operating temperature: 0°C to +40°C
- Ambient operating humidity: 20% to 80% (RH, with no condensation)
- Atmosphere: No corrosive gases.

Impact and Load

- The Servomotor is resistant to impacts of up to 10 G {98 m/s²}. Do not subject it to heavy impacts or loads during transport, installation, or positioning. In addition, do not hold onto the encoder, cable, or connector areas when transporting it.
- Always use a pulley remover to remove pulleys, couplings, or other objects from the shaft.
- Secure cables so that there is no impact or load placed on the cable connector areas.

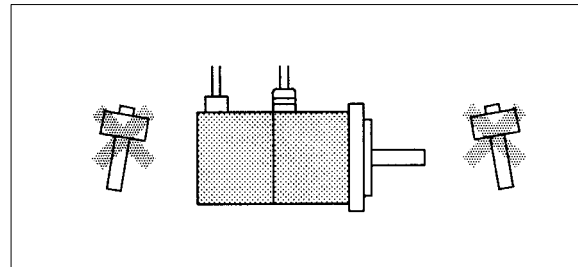

Connecting to Mechanical Systems

- The axial loads for Servomotors are specified in section 5-2-4. If an axial load greater than that specified is applied to a Servomotor, it will reduce the service life of the motor bearings and may damage the motor shaft. When connecting to a load, use couplings that can sufficiently absorb mechanical eccentricity and variation.

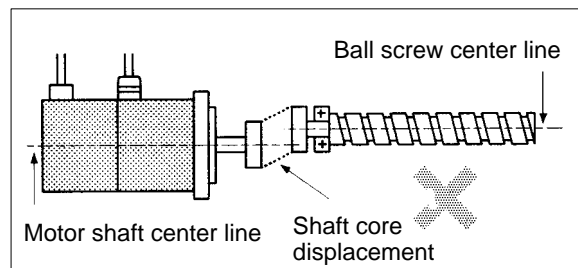

Recommended Coupling

Name	Maker
Oldham coupling	Myghty Co., Ltd

- For spur gears, an extremely large radial load may be applied depending on the gear precision. Use spur gears with a high degree of accuracy (for example, JIS class 2: normal line pitch error of 6 μm max. for a pitch circle diameter of 50 mm). If the gear precision is not adequate, allow backlash to ensure that no radial load is placed on the motor shaft.

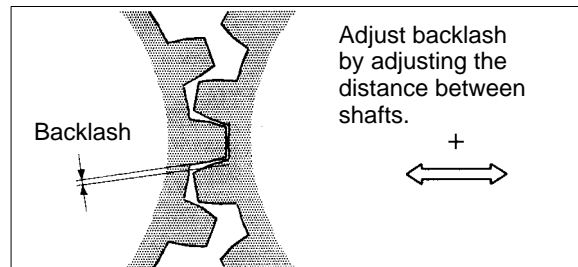

- Bevel gears will cause a load to be applied in the thrust direction depending on the structural precision, the gear precision, and temperature changes. Provide appropriate backlash or take other measures to ensure that no thrust load is applied which exceeds specifications.
- Do not put rubber packing on the flange surface. If the flange is mounted with rubber packing, the motor flange may separate due to the tightening strength.
- When connecting to a V-belt or timing belt, consult the maker for belt selection and tension. A radial load twice the belt tension will be placed on the motor shaft. Do not allow a radial load exceeding specifications to be placed on the motor shaft due to belt tension. If an excessive radial load is applied, the motor shaft may be damaged. Set up the structure so that the radial load can be adjusted. A large radial load may also be applied as a result of belt vibration. Attach a brace and adjust Servo Driver gain so that belt vibration is minimized.

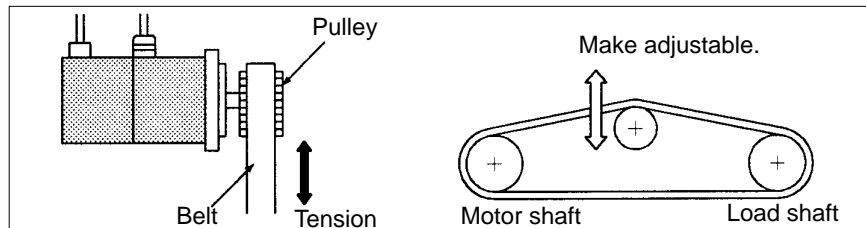
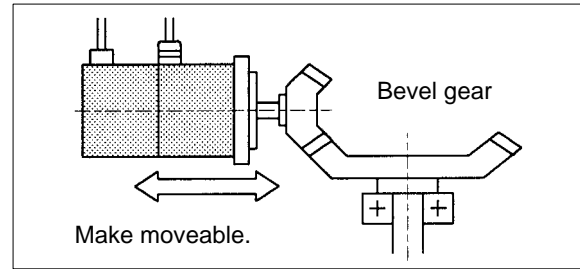

Water and Drip Resistance

- The Servomotor does not have a water-proof structure. Except for the connector areas, the protective structure is covered by the following JEM (The Japan Electrical Manufacturers' Association) standards.
 Models Conforming to UL/cUL Standards and Models Not Conforming to Any Standards: IP-42
 EC Directive Models: IP-44 (except shaft penetration point)
- If the Servomotor is used in an environment in which condensation occurs, water may enter inside of the encoder from the end surfaces of cables due to motor temperature changes. Either take measures to ensure that water cannot penetrate in this way, or use water-proof connectors. Even when machinery is not in use, water penetration can be avoided by taking measures, such as keeping the motor in servo-lock status, to minimize temperature changes.
- If machining oil with surfactants (e.g., coolant fluids) or their spray penetrate inside of the motor, insulation defects or short-circuiting may occur. Take measures to prevent machining oil penetration.

Oil Seals

If the motor shaft is exposed to oil or grease, use a Servomotor with oil seals (available as special specification). (Inquire for details.)

Other Precautions

- Do not apply commercial power directly to the Servomotor. The Servomotors run on synchronous AC and use permanent magnets. Applying 3-phase power will burn out the motor coils.
- Do not carry or otherwise handle the Servomotor by its cable, otherwise the cable may become disconnected or the cable clamp may become damaged.
- Take measures to prevent the shaft from rusting. The shafts are coated with anti-rust oil when shipped, but anti-rust oil or grease should also be applied when connecting the shaft to a load.
- Absolutely do not remove the encoder cover or take the motor apart. The magnet and the encoder are aligned in the Servomotor. If they become misaligned, the motor will not operate.

2-2 Wiring Products Conforming to UL/cUL and Wiring Products Not Conforming to Any Standards

2-2-1 Connecting OMRON Servo Controllers

Use general-purpose control cables (purchased separately) or Servo Relay Units for the C200H to connect U-series AC Servomotors and Servo Drivers to OMRON Servo Controllers.

□ Connecting SYSMAC C-series Position Control Units

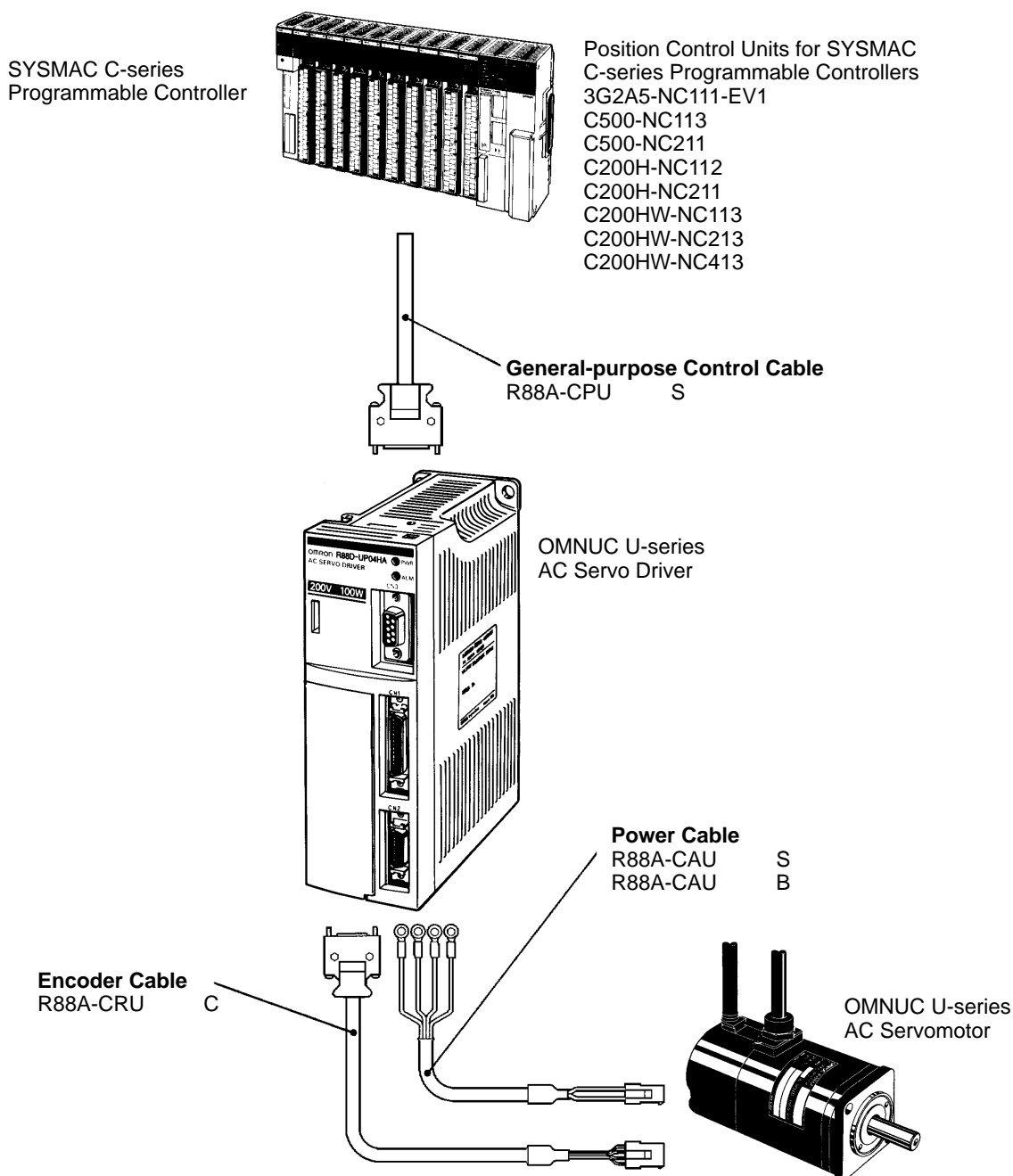

Note Refer to *Chapter 5 Specifications* for connector and cable specifications.

□ Connecting SYSMAC C200H and C500 Position Control Units (Using Servo Relay Units)

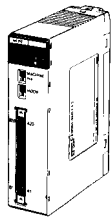

C200H Position Control Unit (1 axis)
C200H-NC112

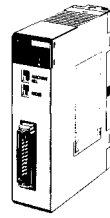

C200H Position Control Unit (2 axes)
C200H-NC211

C500 Position Control Unit
C500-NC113 (1 axis)
C500-NC211 (2 axes)

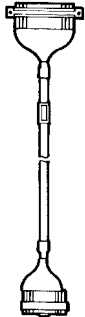

Position Control Unit Connecting Cable (for C200H-NC112)
XW2Z-050J-A1 (0.5 m)
XW2Z-100J-A1 (1 m)

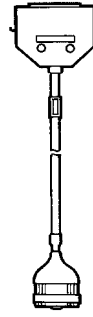

Position Control Unit Connecting Cable (for C200H-NC211 and C500-NC113/211)
XW2Z-050J-A2 (0.5 m)
XW2Z-100J-A2 (1 m)

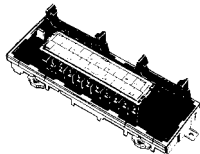

Terminal Connection Unit (for C200H-NC112)
XW2B-20J6-1B

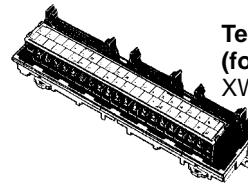

Terminal Connection Unit (for C200H-NC211)
XW2B-40J6-2B

Note 1. Refer to *Section 6* for a connection example for Relay Unit terminal blocks.

Note 2. A Relay Unit is also available for the CQM1-CPU43-V1, CQM1H-PLB21 (with pulse I/O capability).

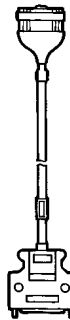

Servo Driver Connecting Cable

XW2Z-100J-B1 (1 m)
XW2Z-200J-B1 (2 m)

Note Two cables are required when using the C200H-NC211, C500-NC211 (two axes).

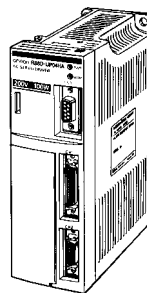

OMNUC U-series
AC Servo Driver

Encoder Cable
R88A-CRU

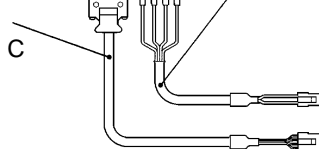

Power Cable
R88A-CAU S
R88A-CAU B

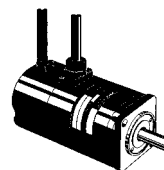

OMNUC U-series
AC Servomotor

Note Refer to documentation on the XW2B Servo Relay Unit for details.

□ Connecting SYSMAC C200HX/HG/HE Position Control Units (Using Servo Relay Units)

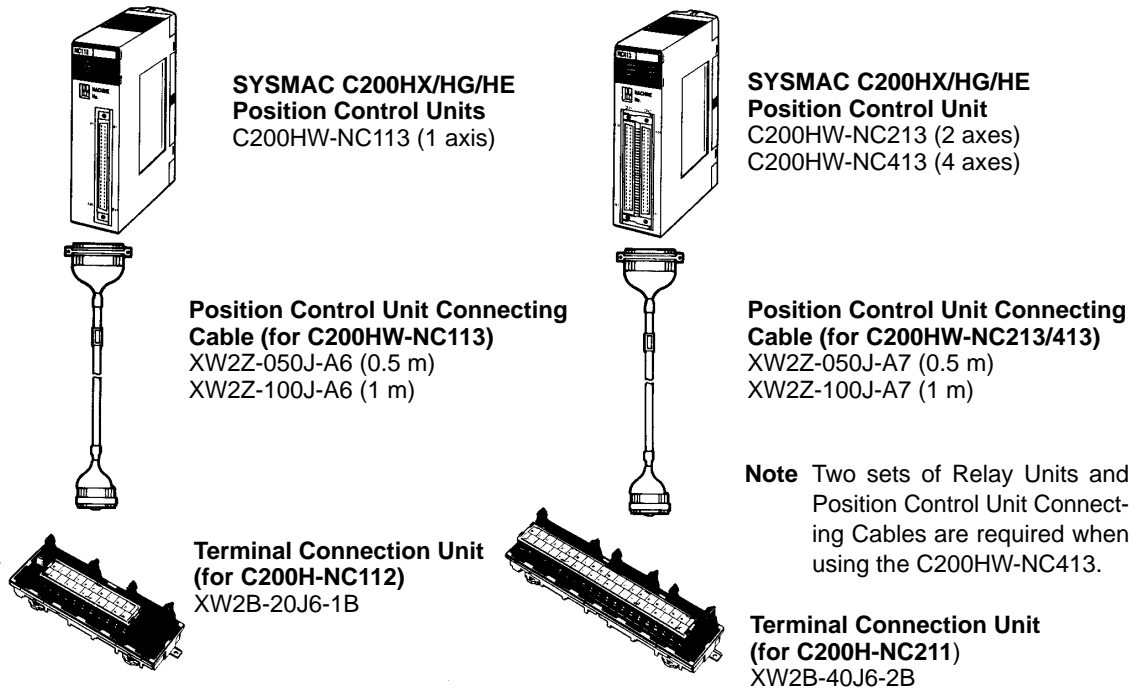

Note Two sets of Relay Units and Position Control Unit Connecting Cables are required when using the C200HW-NC413.

- Note 1.** Refer to *Section 6* for a connection example for Relay Unit terminal blocks.
- Note 2.** A Relay Unit is also available for the CQM1-CPU43-V1, CQM1H-PLB21 (with pulse I/O capability).

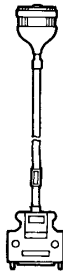

Servo Driver Connecting Cable
XW2Z-100J-B1 (1 m)
XW2Z-200J-B1 (2 m)

Note Two cables are required when using the C200HW-NC213 (2 axes) and four cables are required when using the C200HW-NC413 (4 axes).

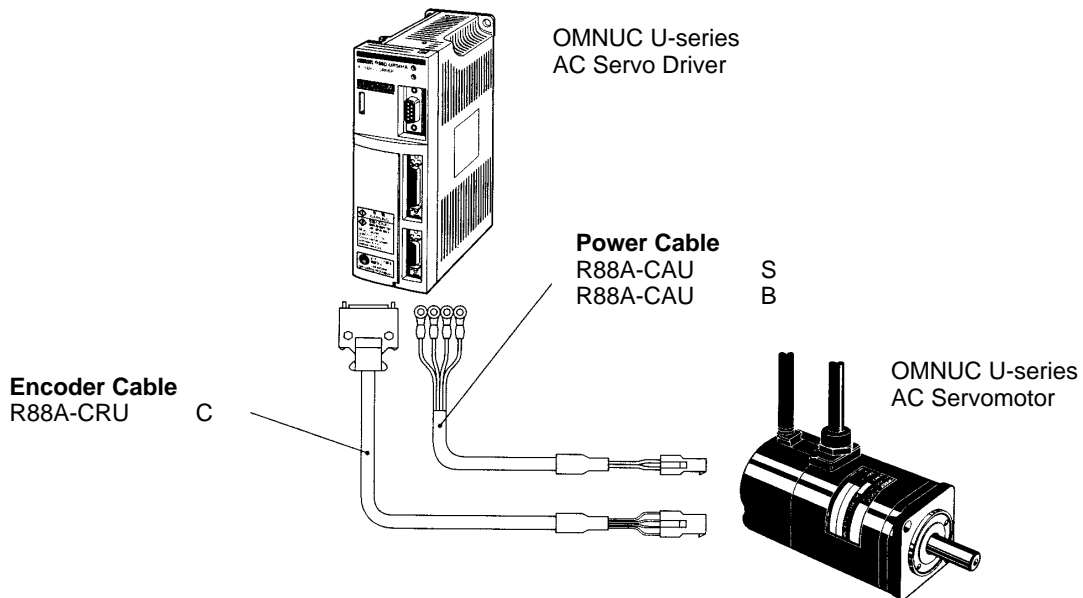

Note Refer to documentation on the XW2B Servo Relay Unit for details.

2-2-2 Connector-Terminal Conversion Unit

The AC Servo Driver can be easily connected to the Connector-Terminal Conversion Unit through a special cable without soldering.

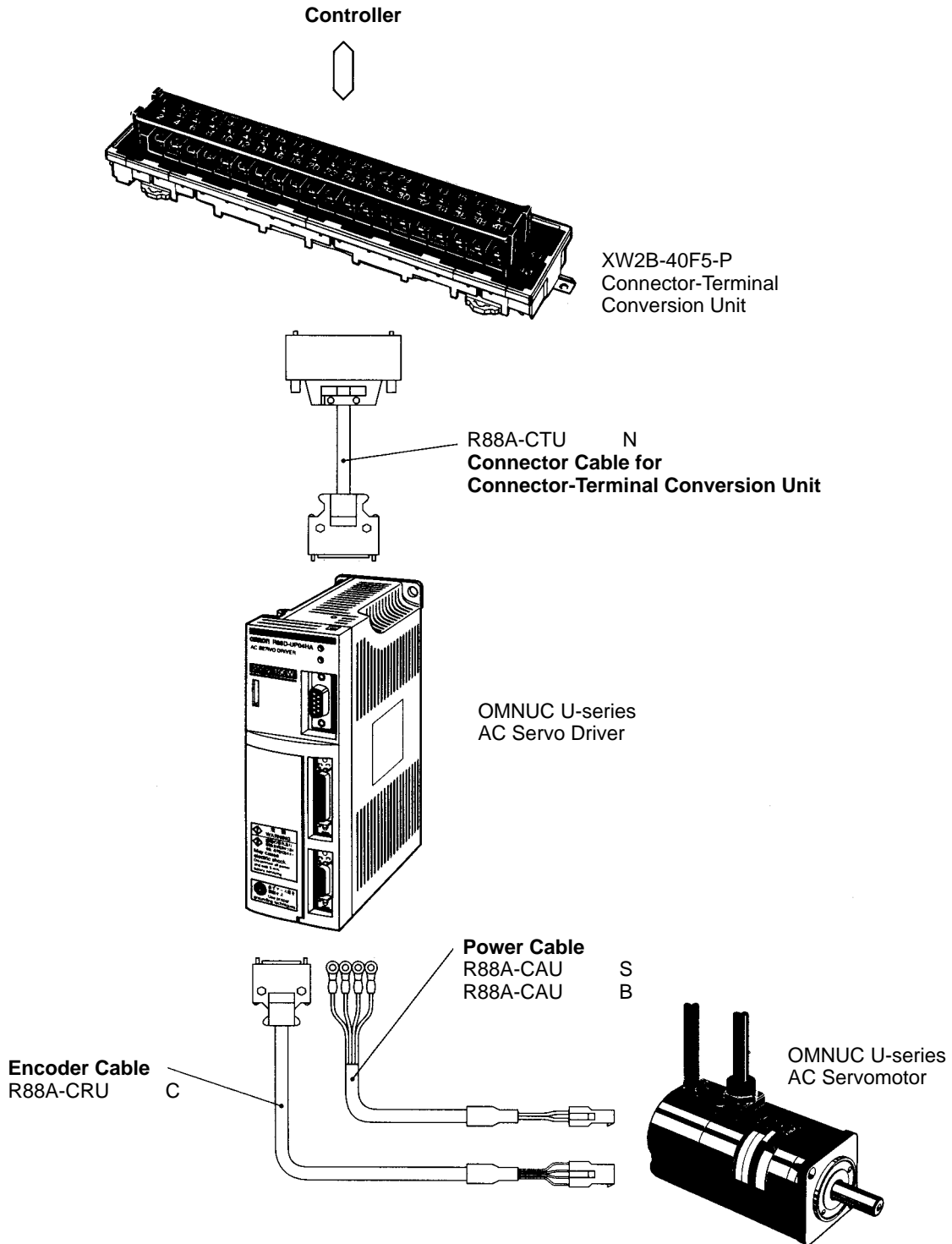

Note Refer to *Chapter 5 Specifications* for connector and cable specifications.

2-2-3 Wiring Servo Drivers

Provide proper wire diameters, ground systems, and noise resistance when wiring terminal blocks.

□ Wiring Terminal Blocks

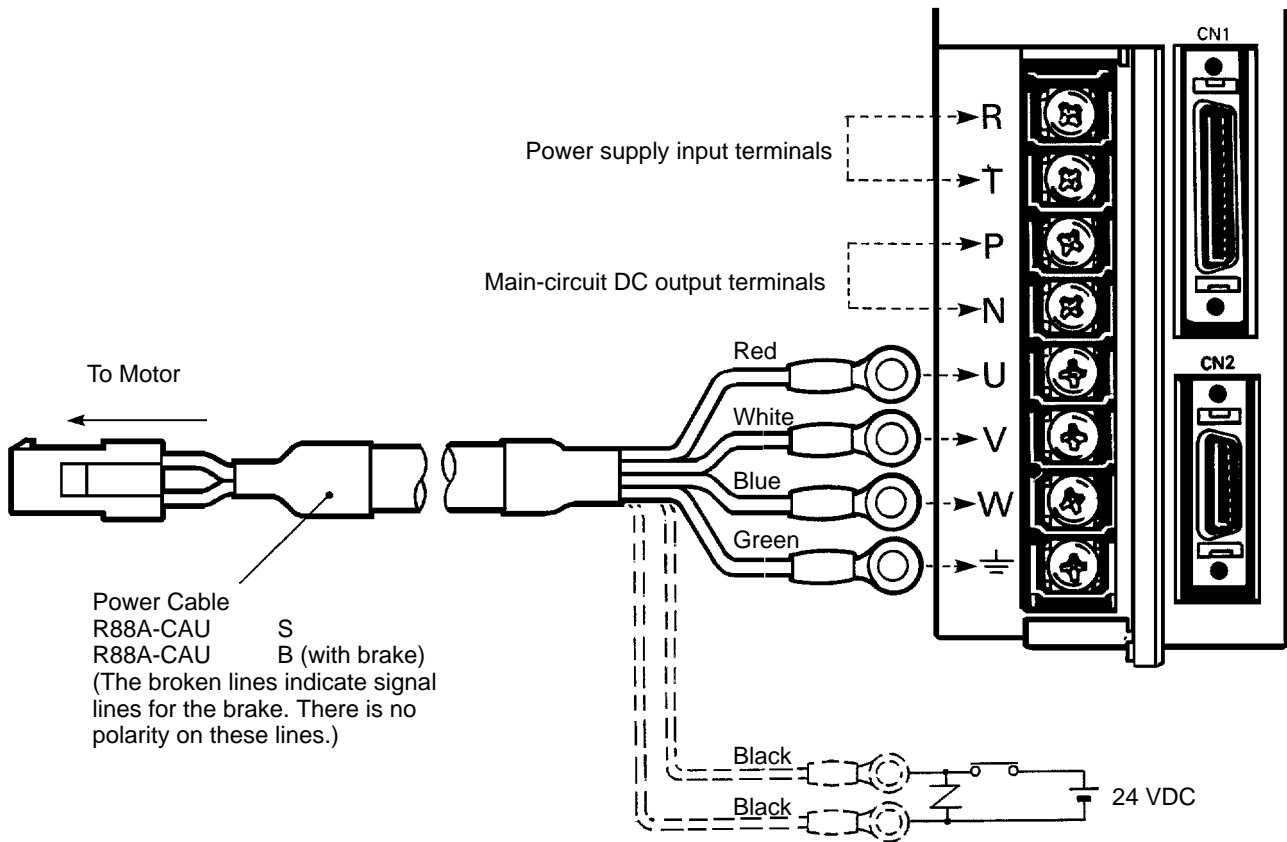

Terminal label	Name	Function	
R	Power supply input	The commercial power supply input terminals for the main circuit and the control circuitry. R88D-UP H(A): Single-phase 200/230 VAC (170 to 253 V) 50/60 Hz R88D-UP L(A): Single-phase 100/115 VAC (85 to 127 V) 50/60 Hz1	
T			
P	Main circuit DC output	The terminals for connecting Regeneration Units (R88A-RG08UA). Connect these terminals when there is a high level of regenerative energy. (See note.)	
N			
U	Motor connection terminals	Red	These are the output terminals to the Servomotor. Be careful to wire them correctly.
V		White	
W		Blue	
⏏	Frame ground	Green	The ground terminal for both the motor output and power supply input. Ground to a class-3 ground (to 100 Ω or less) or better.

Note Refer to 3-8 Regenerative Energy Absorption for the methods to calculate regenerative energy.

Terminal Block Current and Wire Sizes

The following table shows the rated effective currents flowing to the Servo Driver and the sizes of the electrical wires.

Servo Drivers with 200-VAC Input (R88D-UP H(A))

Driver (Watts)	R88D-UP02H(A) (30 W)	R88D-UP03H(A) (50 W)	R88D-UP04H(A) (100 W)	R88D-UP08H(A) (200 W)	R88D-UP12H(A) (400 W)	R88D-UP20H(A) (750 W)
Power supply input current (R, T)	1.3 A	1.5 A	2.5 A	4.0 A	6.0 A	11.0 A
Motor output current (U, V, W)	0.42 A	0.6 A	0.87 A	2.0 A	2.6 A	4.4 A
Power supply input terminal wire size	0.75 mm ² or AWG 18 min.				1.25 mm ²	2.0 mm ²
Motor output terminal wire size	0.5 mm ² or AWG 20			AWG 20 (see note) to AWG 18		
	Use OMRON standard cable. The applicable wire size for motor connectors is AWG22 to AWG18.					
Ground terminal wire size	Use 2.0-mm ² external ground wires. Use the same wire as used for the motor output.					

Note If the cable length is 15 meters or longer for a 750-W Servomotor, the momentary maximum torque at rotation speeds of 2,500 r/min or higher may drop by approximately 7%.

Servo Drivers with 100-VAC Input (R88D-UP L(A))

Driver model (Watts)	R88D-UP03L(A) (30 W)	R88D-UP04L(A) (50 W)	R88D-UP10L(A) (100 W)	R88D-UP12L(A) (200 W)	R88D-UP15LA (300 W)
Power supply input current (R, T)	2.0 A	2.6 A	4.5 A	8.0 A	10.0 A
Motor output current (U, V, W)	0.63 A	0.7 A	2.2 A	2.7 A	3.7 A
Power supply input terminal wire size	0.75 mm ² or AWG 18 min.			1.25 mm ²	2 mm ²
Motor output terminal wire size	0.5 mm ² or AWG 20		AWG 20 to AWG 18		
	Use OMRON standard cable. The applicable wire size for motor connectors is AWG22 to AWG18.				
Ground terminal wire size	Use 2.0-mm ² external ground wires. Use the same wire as used for the motor output.				

Wire Sizes and Allowable Current

The following table shows allowable currents when there are three electrical wires. Use values equal to or lower than the specified values.

Heat-resistant Vinyl Wiring, UL1007, Rated Temperature 80°C (Reference Value)

AWG size	Nominal cross-sectional area (mm ²)	Configuration (wires/mm ²)	Conductive resistance (Ω/km)	Allowable current (A) for ambient temperature		
				40°C	50°C	60°C
20	0.5	19/0.18	39.5	6.6	5.6	4.5
---	0.75	30/0.18	26.0	8.8	7.0	5.5
18	0.9	37/0.18	24.4	9.0	7.7	6.0
16	1.25	50/0.18	15.6	12.0	11.0	8.5

2-2-4 Wiring for Noise Resistance

□ Wiring Method

Noise resistance will vary greatly depending on the wiring method used. Resistance to noise can be increased by paying attention to the items described below.

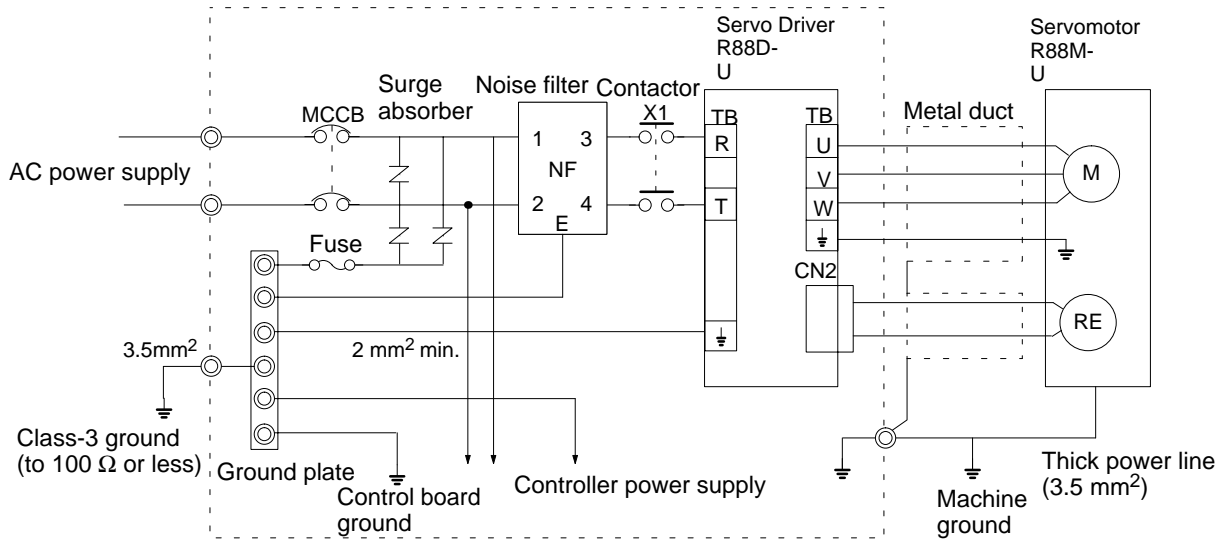

- Ground the motor’s frame to the machine ground when the motor is on a movable shaft.
- Use a grounding plate for the frame ground for each Unit, as shown in the illustration, and ground to a single point.
- Use ground lines with a minimum thickness of 3.5 mm², and arrange the wiring so that the ground lines are as short as possible.
- If no-fuse breakers (MCCB) are installed at the top and the power supply line is wired from the lower duct, use metal tubes for wiring and make sure that there is adequate distance between the input lines and the internal wiring. If input and output lines are wired together, noise resistance will decrease.
- No-fuse breakers (MCCB), surge absorbers, and noise filters (NF) should be positioned near the input terminal block (ground plate), and I/O lines should be isolated and wired using the shortest means possible.
- Wire the noise filter as shown at the left in the following illustration. The noise filter should be installed at the entrance to the control panel whenever possible.

Good: Separate input and output

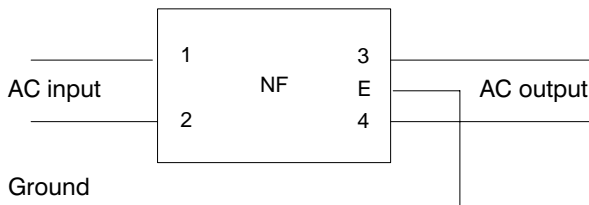

NO: Noise not filtered effectively

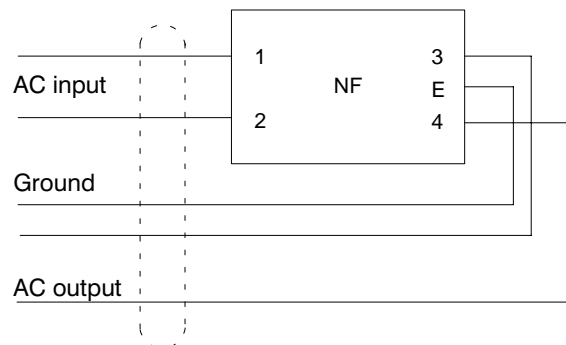

- Use twisted-pair cables for the power supply cables whenever possible, or bind the cables.

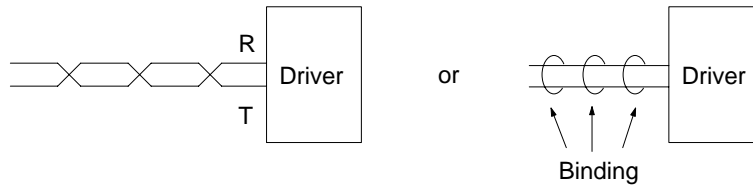

- Separate power supply cables and signal cables when wiring.

□ Selecting Components

This section describes the standards used to select components required to increase noise resistance. Select these components based on their capacities, performances, and applicable ranges.

Recommended components have been listed; refer to the manufacturer of each component for details.

No-fuse Breakers (MCCB)

When selecting no-fuse breakers, take into consideration the maximum input current and the inrush current. The momentary maximum output for a servo system is approximately three times that of the rated output, and a maximum output of three seconds can be executed. Therefore, select no-fuse breakers with an operating time of at least five seconds at 300% of the rated maximum output. General-purpose and low-speed no-fuse breakers are generally suitable. Refer to the table in 2-2-3 *Terminal Block Wiring* for the power supply input currents for each motor, and then add the current consumption for the number of shafts, other controllers, etc., to make the selection.

The Servo Driver inrush current flows at a maximum of 50 A for 20 ms when 200 V is input. With low-speed no-fuse breakers, a inrush current 7 to 8 times the rated current flows for 0.1 second. When making the selection, take into consideration the entire inrush current for the system.

Surge Absorbers

Use surge absorbers to absorb surges from power supply input lines due to lightning, abnormal voltages, etc. When selecting surge absorbers, take into account the varistor voltage, the amount of surge immunity, and the amount of energy resistance. For 200-VAC systems, use a varistor voltage of 470 V. The surge absorbers shown in the following table are recommended.

Maker	Model	Varistor voltage	Max. limit voltage	Surge immunity	Energy resistance	Fuse capacity	Type
Matsushita Electric Parts	ERZV10D471(W)	470 V	775 V	1,250 A	45 J	3 to 5 A	Disk
	ERZV14D471(W)	470 V	775 V	2,500 A	80 J	3 to 10 A	
	ERZV20D471(W)	470 V	775 V	4,000 A	150 J	5 to 15 A	
	ERZC20EK471(W)	470 V	775 V	5,000A	150 J	---	Block
Ishizuka Electronics Co.	Z10L471	470 V	773 V	1,000A	15 W s	3 to 5 A	Disk
	Z15L471	470 V	738 V	1,250 A	20 W s	3 to 5 A	
	Z21L471	470 V	733 V	3,000 A	30 W s	5 to 10 A	
	Z25M471S	470 V	810 V	10,000 A	235 J	---	Block
Okaya Electric Ind.	R-A-V -781BWZ-2A	---	783 V	1,000 A	---	---	Block
	R-A-V -781BXZ-2A	---	783 V	1,000 A	---	---	
	R-A-V -401.621BYR-2	---	620 V	1,000 A	---	---	

Note 1. The (W) Matsushita models are UL and CSA certified.

- Note 2.** Refer to manufacturers documentation for operating details.
- Note 3.** The surge immunity is for a standard impulse current of 8/20 μ s. If pulses are wide, either decrease the current or change to a larger-capacity surge absorber.
- Note 4.** The energy resistance is the value for 2 ms. It may not be possible to retard high-energy pulses at less than 700 V. In that case, absorb surges with an insulated transformer or reactor.

Noise Filters for Power Supply Input

Use a noise filter to attenuate extraneous noise and to diminish noise radiation from the Servo Driver. Select a noise filter with a load current of at least twice the rated current. The following table shows noise filters that reduce by 40 dB noise between 200 kHz and 30 MHz.

Maker	Model	Rated current	Remarks
Token	LF-210N	10 A	For single-phase
	LF-215N	15 A	
	LF-220N	20 A	

To attenuate noise at frequencies of 200 kHz or less, use an insulated transformer and a noise filter. For high frequencies of 30 MHz or more, use a ferrite core and a high-frequency noise filter with a through-type capacitor.

Noise Filters for Motor Output

Use noise filters without built-in capacitors on the Servomotor output lines. Output lines cannot use the same noise filters as the power supply. General-purpose noise filters are made for a power supply frequency of 50/60 Hz; if they are connected to an output of 7.8 to 11 kHz (the Servo Driver PWM frequency), an extremely large leakage current (approx. 100 times normal) will flow to the capacitor in the noise filter. The following table shows the noise filters that are recommended for motor output.

Maker	Model	Rated current	Remarks
Token	LF-310KA	10 A	Three-phase block noise filter
	LF-320KA	20 A	
	ESD-R-47B	---	EMI core for radiation noise
Fuji Electrochemical Co.	RN80UD	---	10-turn for radiation noise

- Note 1.** The Servomotor output lines cannot use the same noise filters used for power supplies.
- Note 2.** Typical noise filters are used with power supply frequencies of 50/60 Hz. If these noise filters are connected to outputs of 7.8 to 11 kHz (the Servo Driver's PWM frequency), a very large (about 100 times larger) leakage current will flow through the noise filter's condenser and the Servo Driver could be damaged.

Surge Killers

Install surge killers for loads that have induction coils, such as relays, solenoids, brakes, clutches, etc. The following table shows types of surge killers and recommended products.

Type	Features	Recommended products
Diode	Diodes are relatively small devices such as relays used for loads when reset time is not an issue. The reset time is increased because the surge voltage is the lowest when power is cut off. Used for 24/48-VDC systems.	Use a fast-recovery diode with a short reverse recovery time. Fuji Electric Co., ERB44-06 or equivalent
Thyristor or Varistor	Thyristor and varistor are used for loads when induction coils are large, as in electromagnetic brakes, solenoids, etc., and when reset time is an issue. The surge voltage when power is cut off is approximately 1.5 times that of the varistor.	Select varistor voltage as follows: 24-VDC system varistor: 39 V 100-VDC system varistor: 200 V 100-VAC system varistor: 270 V 200-VAC system varistor: 470 V
Capacitor + resistor	Use capacitors and resistors for vibration absorption of surge when power is cut off. The reset time can be shortened by proper selection of the capacitor or resistor. Used for 100/200-VAC circuit contactors.	Okaya Electric Ind. CR-50500 0.5 μ F-50 Ω CRE-50500 0.5 μ F-50 Ω S2-A-0 0.2 μ F-500 Ω

Note Thyristors and varistors are made by the following companies. Refer to manufacturers documentation for operating details. Thyristors: Ishizuka Electronics Co.
Varistors: Ishizuka Electronics Co., Matsushita Electric Parts

Contactors

When selecting contactors, take into consideration the circuit’s inrush current and the momentary maximum current. The Servo Driver inrush current is 50 A, and the momentary maximum current is approximately twice the rated current. The following table shows the recommended contactors.

Maker	Model	Rated current	Momentary maximum current	Coil voltage
OMRON	G6C-2BND	10 A	---	24 VDC
	LY2-D	10 A	---	24 VDC
	G7L-2A-BUBJ	25 A	---	24 VDC, 200 to 240 VAC
	J7AN-E3	15 A	120 A	24 VDC
	LC1-D093A60	11 A	200 A	24 VDC, 200/220 VAC, 200 to 240 VAC

Leakage Breakers

Select leakage breakers designed for inverters.

Since switching operations take place inside the Servo Driver, high-frequency current leaks from the armature of the Servomotor. With inverter leakage breakers, high-frequency current is not detected, preventing the breaker from operating due to leakage current.

When selecting leakage breakers, remember to also add the leakage current from devices other than the Servomotor, such as machines using a switching power supply, noise filters, inverters, and so on.

For detailed information about the selection methods of leakage breakers, refer to catalogs provided by manufacturers.

The following table shows the Servomotor leakage currents for each Servo Driver.

Driver	Leakage current (direct) (including high-frequency current)	Leakage current (resistor-capacitor, in commercial power supply frequency range)
R88D-UP02H(A) to -UP08H(A)	80 mA	3 mA
R88D-UP12H(A)	60 mA	4 mA
R88D-UP20H(A)	110 mA	5 mA

Note 1. Leakage current values shown above are for motor power lines of 10 m or less. The values will change depending on the length of power cables and the insulation.

Note 2. Leakage current values shown above are for normal temperatures and humidity. The values will change depending on the temperature and humidity.

Note 3. Leakage current for 100-VAC-input Servomotors is approximately half that of the values shown above.

Improving Encoder Cable Noise Resistance

Signals from the encoder are either A, B, or S phase. The frequency for A- or B-phase signals is 154 kHz max., while the transmission speed for S-phase signals is 616 kbps. Follow the wiring methods outlined below to improve encoder noise resistance.

- Be sure to use dedicated encoder cables.
- If lines are interrupted in the middle, be sure to connect them with connectors, making sure that the cable insulation is not peeled off for more than 50 mm. In addition, be sure to use shielded wire.
- Do not coil cables. If cables are long and are coiled, mutual induction and inductance will increase and will cause malfunctions. Be sure to use cables fully extended.
- When installing noise filters for encoder cables, use ferrite cores. The following table shows the recommended ferrite core models.

Maker	Name	Model
Token	EMI core	ESD-QR-25-1
TDK	Clamp filter	ZCAT2032-0930
		ZCAT3035-1330
		ZCAT2035-0930A

- Do not wire the encoder cable in the same duct as power cables and control cables for brakes, solenoids, clutches, and valves.

Improving Control I/O Signal Noise Resistance

Position can be affected if control I/O signals are influenced by noise. Follow the methods outlined below for the power supply and wiring.

- Use completely separate power supplies for the control power supply (especially 24 VDC) and the external operation power supply. In particular, be careful not to connect two power supply ground wires. Install a noise filter on the primary side of the control power supply.
- Use separate power supplies for control power and for power for the pulse command and deviation counter reset input lines. Do not connect the ground wires for these two power supplies to the same ground.
- We recommend line drivers for the pulse command and deviation counter reset outputs.
- For the pulse command and deviation counter reset input lines, be sure to use twisted-pair shielded cable, and connect both ends of the shield wire to ground.

- If the control power supply wiring is long, noise resistance can be improved by adding 1- μ F laminated ceramic capacitors between the control power supply and ground at the Servo Driver input section and the controller output section.
- For encoder output (A, B, and Z phase) lines, be sure to use twisted-pair shielded cable, and connect both ends of the shield wire to ground.
- Wiring must be 1 m or less when using open-collector outputs.

2-2-5 Peripheral Device Connection Examples

□ Connecting to Peripheral Devices

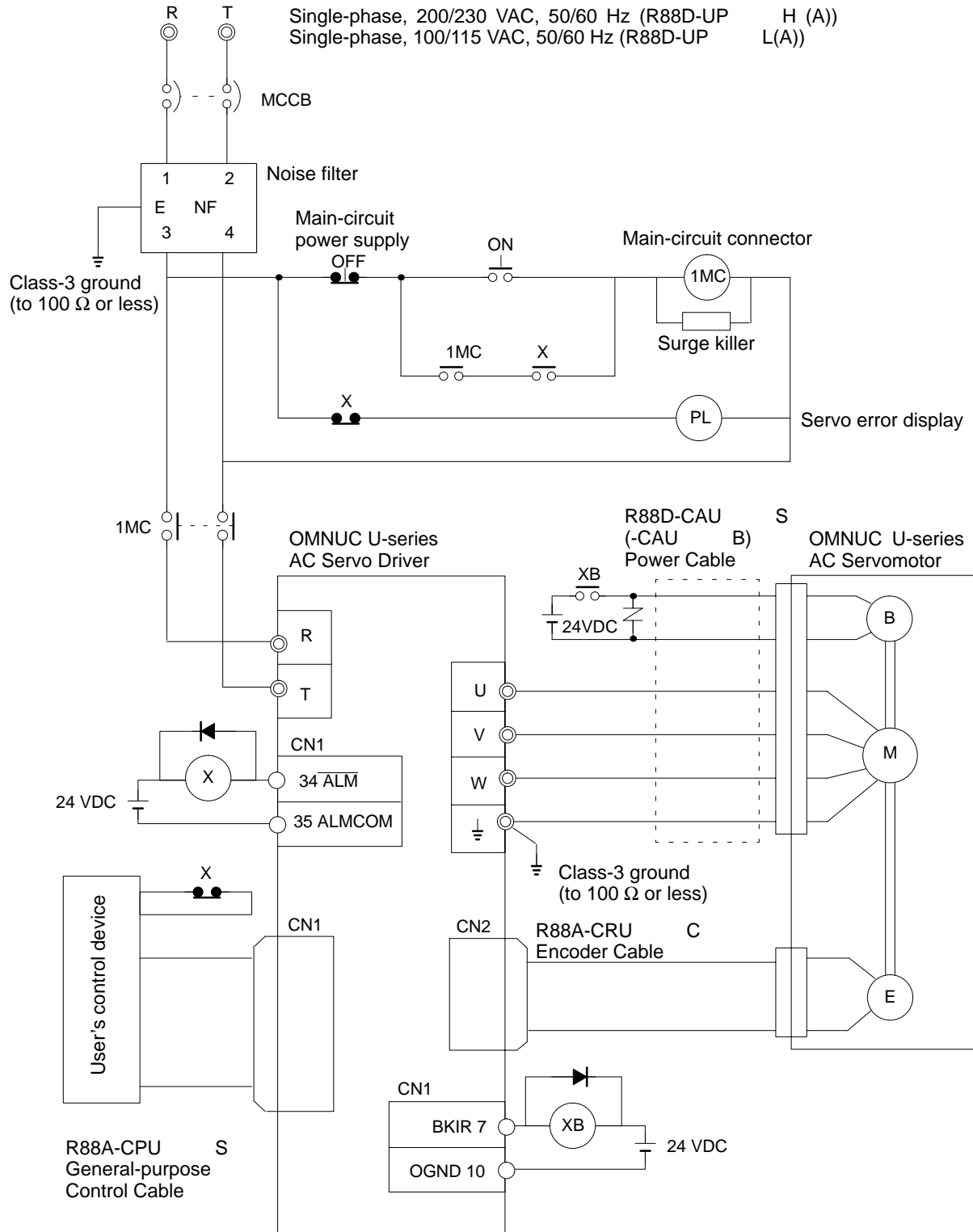

□ Connecting a Regeneration Unit

Single-phase, 200/230 VAC, 50/60 Hz (R88D-UP H(A))
 Single-phase, 100/115 VAC, 50/60 Hz (R88D-UP L(A))

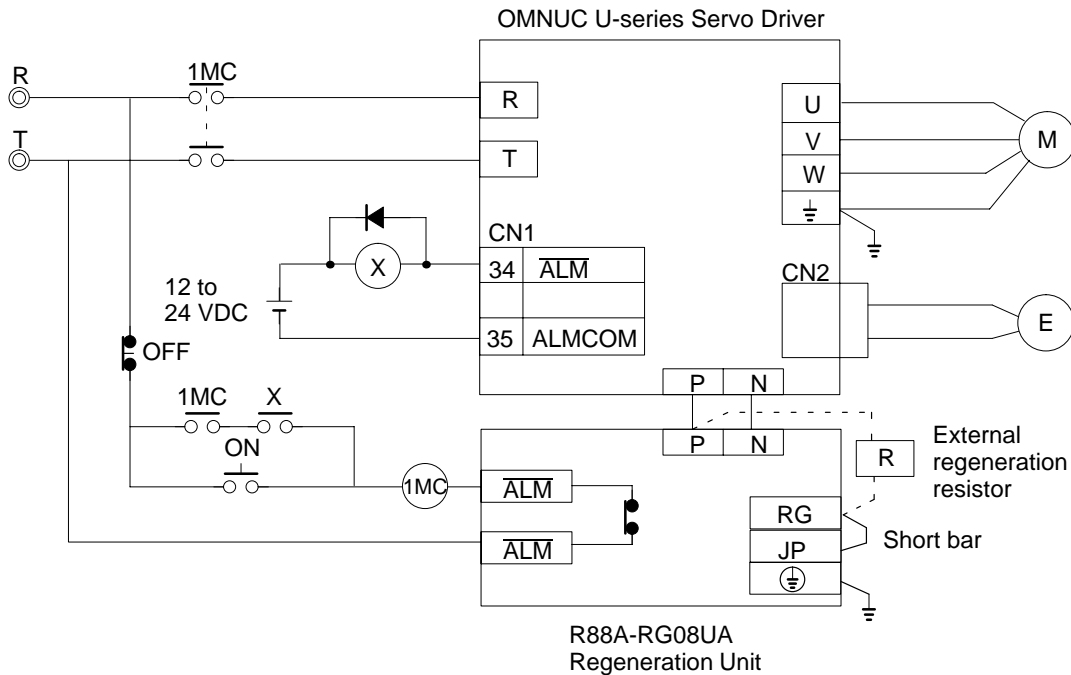

- Note 1.** When using the external regeneration resistor, disconnect the short bar between the RG and JP terminals. The internal circuit may be damaged if the external regeneration resistor is connected with the shortbar still connected between the RG and JP terminals.
- Note 2.** Connect the external regeneration resistor between the P and RG terminals.
- Note 3.** The Regeneration Unit does not conform to EC Directives.
- Note 4.** When connecting the ALM output, form a sequence so that the power supply is shut OFF when the contacts open. The Unit may be damaged if the ALM output is used without forming a power shut-off sequence.

2-3 Wiring Products Conforming to EC Directives

2-3-1 Connecting Servo Controllers

Use general-purpose control cables (purchased separately) to connect U-series AC Servomotors and Servo Drivers to OMRON Servo Controllers.

□ Connecting to a Servo Controller

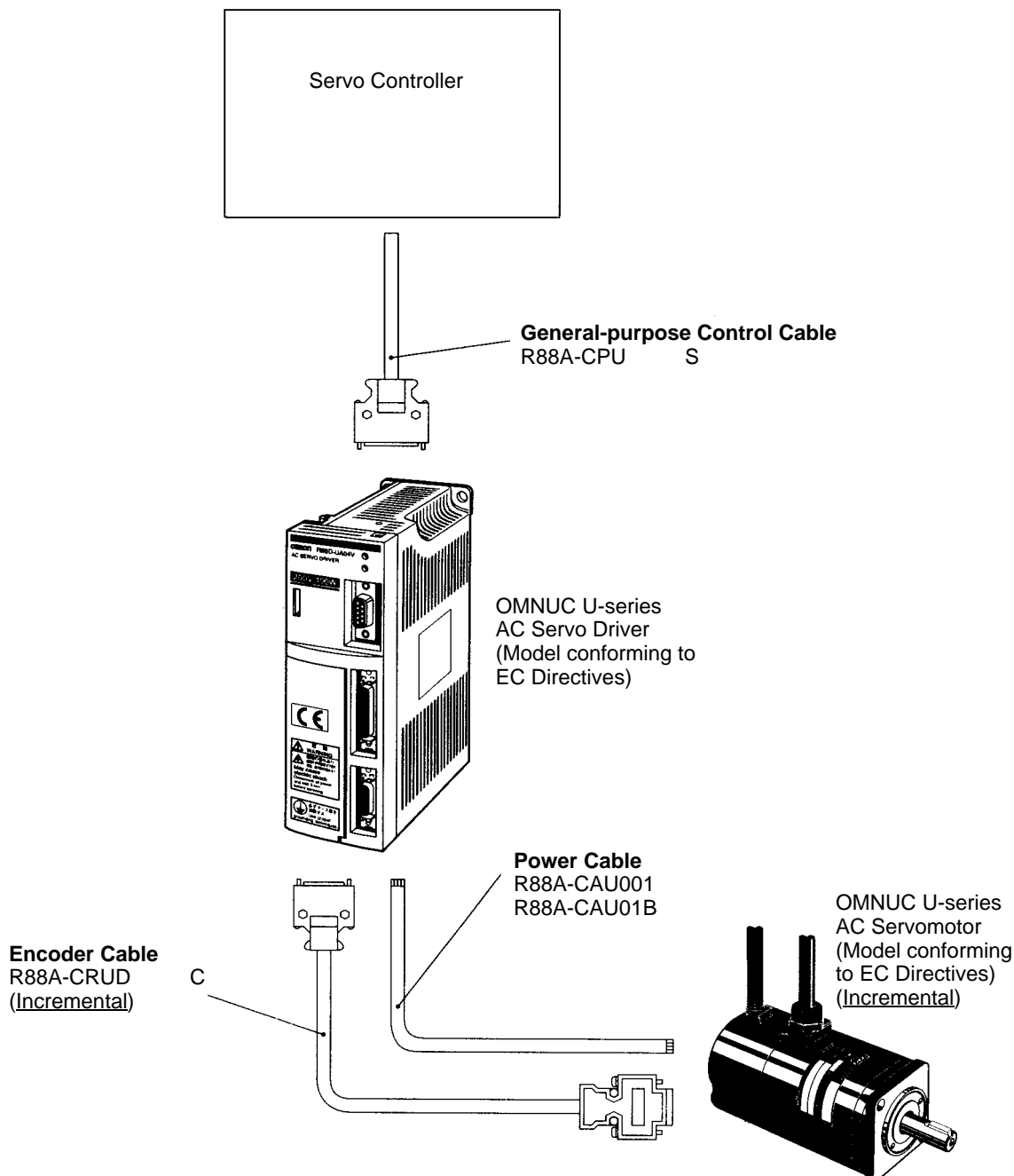

Note Refer to *Chapter 5 Specifications* for connector and cable specifications.

2-3-2 Wiring Servo Drivers

Provide proper wire diameters, ground systems, and noise resistance when wiring terminal blocks.

□ Wiring Terminal Blocks

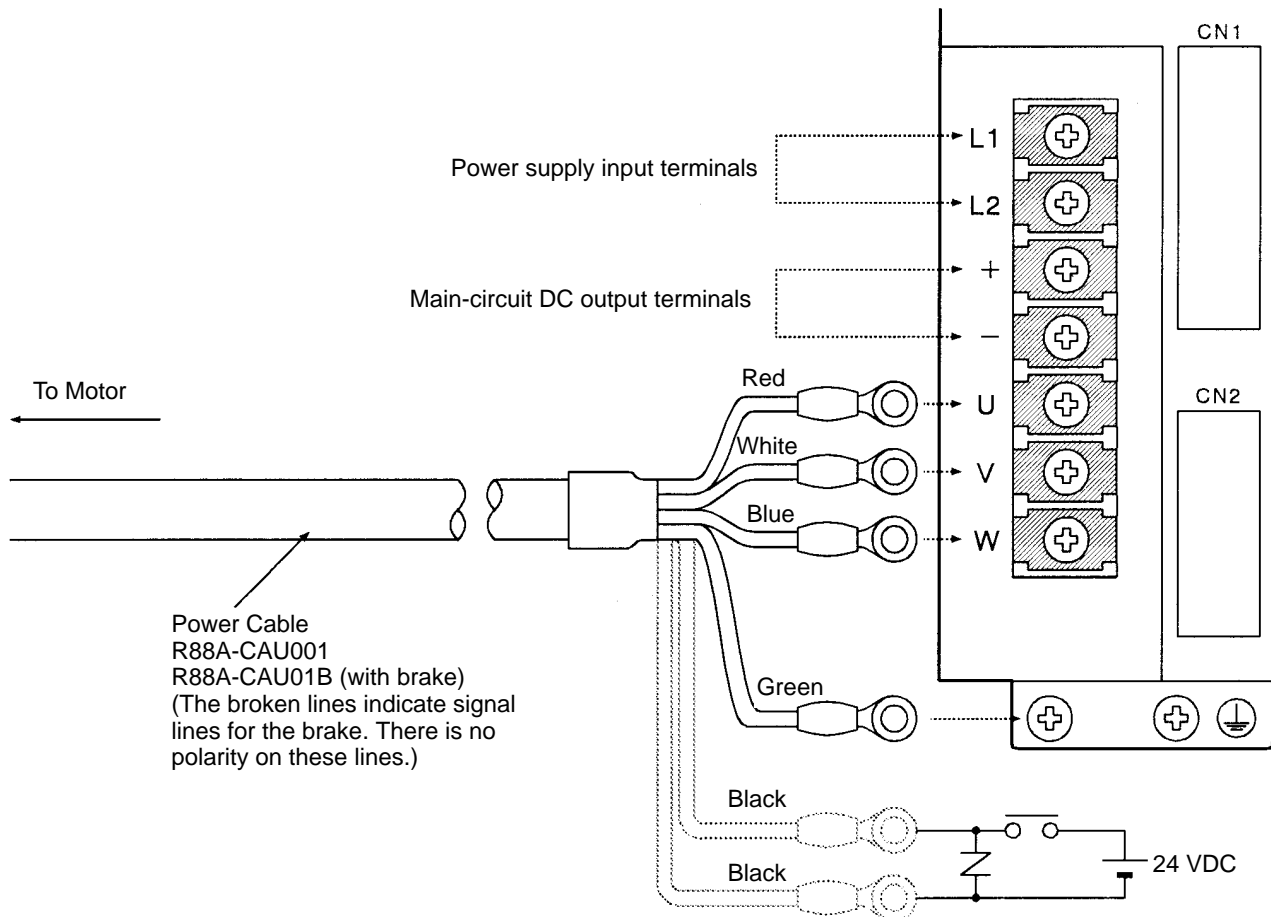

Terminal label	Name	Function	
L1	Power supply input	The commercial power supply input terminals for the main circuit and the control circuitry.	
L2			
+	Main circuit DC output	When there is a high level of regenerative energy in a multi-axis system, the + terminals can be connected together and the – terminals can be connected together to increase the ability to absorb regenerative energy	
–			
U	Motor connection terminals	Red	These are the output terminals to the Servomotor. Be careful to wire them correctly.
V		White	
W		Blue	
⏏	Frame ground	Green	Ground to a class-3 ground (to 100 Ω or less) or better.

Note Refer to 3-8 Regenerative Energy Absorption for the methods to calculate regenerative energy.

Terminal Block Current and Wire Sizes

The following table shows the rated effective currents flowing to the Servo Driver and the sizes of the electrical wires.

Servo Drivers with 200-VAC Input (R88D-UP V)

Driver (Watts)	R88D-UP02V (30 W)	R88D-UP03V (50 W)	R88D-UP04V (100 W)	R88D-UP08V (200 W)	R88D-UP12V (400 W)	R88D-UP20V (750 W)
Power supply input current (L1, L2)	1.3 A	1.5 A	2.5 A	4.0 A	6.0 A	11.0 A
Motor output current (U, V, W)	0.42 A	0.6 A	0.87 A	2.0 A	2.6 A	4.4 A
Power supply input terminal wire size	0.75 mm ² or AWG 18 min.				1.25 mm ²	2.0 mm ²
Motor output terminal wire size	0.5 mm ² or AWG 20			AWG 20 (see note) to AWG 18		
	Use OMRON standard cable. The applicable wire size for motor connectors is AWG22 to AWG18.					
Protective earth terminal wire size	Use 2.0-mm ² external ground wires. Use the same wire as used for the motor output.					

Note If the cable length is 15 meters or longer for a 750-W Servomotor, the momentary maximum torque at rotation speeds of 2,500 r/min or higher may drop by approximately 7%.

Servo Drivers with 100-VAC Input (R88D-UP W)

Driver model (Watts)	R88D-UP03L(A) (30 W)	R88D-UP04L(A) (50 W)	R88D-UP10L(A) (100 W)	R88D-UP12L(A) (200 W)	R88D-UP15LA (300 W)
Power supply input current (L1, L2)	2.0 A	2.6 A	4.5 A	8.0 A	10.0 A
Motor output current (U, V, W)	0.63 A	0.7 A	2.2 A	2.7 A	3.7 A
Power supply input terminal wire size	0.75 mm ² or AWG 18 min.			1.25 mm ²	2 mm ²
Motor output terminal wire size	0.5 mm ² or AWG 20		AWG 20 to AWG 18		
	Use OMRON standard cable. The applicable wire size for motor connectors is AWG22 to AWG18.				
Protective earth terminal wire size	Use 2.0-mm ² external ground wires. Use the same wire as used for the motor output.				

Wire Sizes and Allowable Current

The following table shows allowable currents when there are three electrical wires. Use values equal to or lower than the specified values.

Heat-resistant Vinyl Wiring, UL1007, Rated Temperature 80°C (Reference Value)

AWG size	Nominal cross-sectional area (mm ²)	Configuration (wires/mm ²)	Conductive resistance (Ω/km)	Allowable current (A) for ambient temperature		
				40°C	50°C	60°C
20	0.5	19/0.18	39.5	6.6	5.6	4.5
---	0.75	30/0.18	26.0	8.8	7.0	5.5
18	0.9	37/0.18	24.4	9.0	7.7	6.0
16	1.25	50/0.18	15.6	12.0	11.0	8.5

2-3-3 Wiring Products Conforming to EMC Directives

Models conforming to EC Directive will meet the requirements of the EMC Directives EN55011 Class A Group 1 (EMI) and EN50082-2 (EMS) if they are wired under the conditions described in this section. If the connected devices, wiring, and other conditions cannot be made to fulfill the installation and wiring conditions when the product is incorporated into a machine, the compliance of the overall machine must be confirmed.

The following conditions must be met to conform to EMC Directives.

- The Servo Driver must be installed in a metal case (control panel).
- Noise filters and surge absorbers must be installed on all power supply lines.
- Shielded cables must be used for all I/O signal lines and encoder lines. (Use tin-plated, soft copper wires for the shield weaving.)
- All cables leaving the control panel must be wired in metal ducts or conduits with blades.
- Ferrite cores must be attached to the shielded cable and the shield must be clamped directly to the ground plate to ground it.

□ Wiring Methods

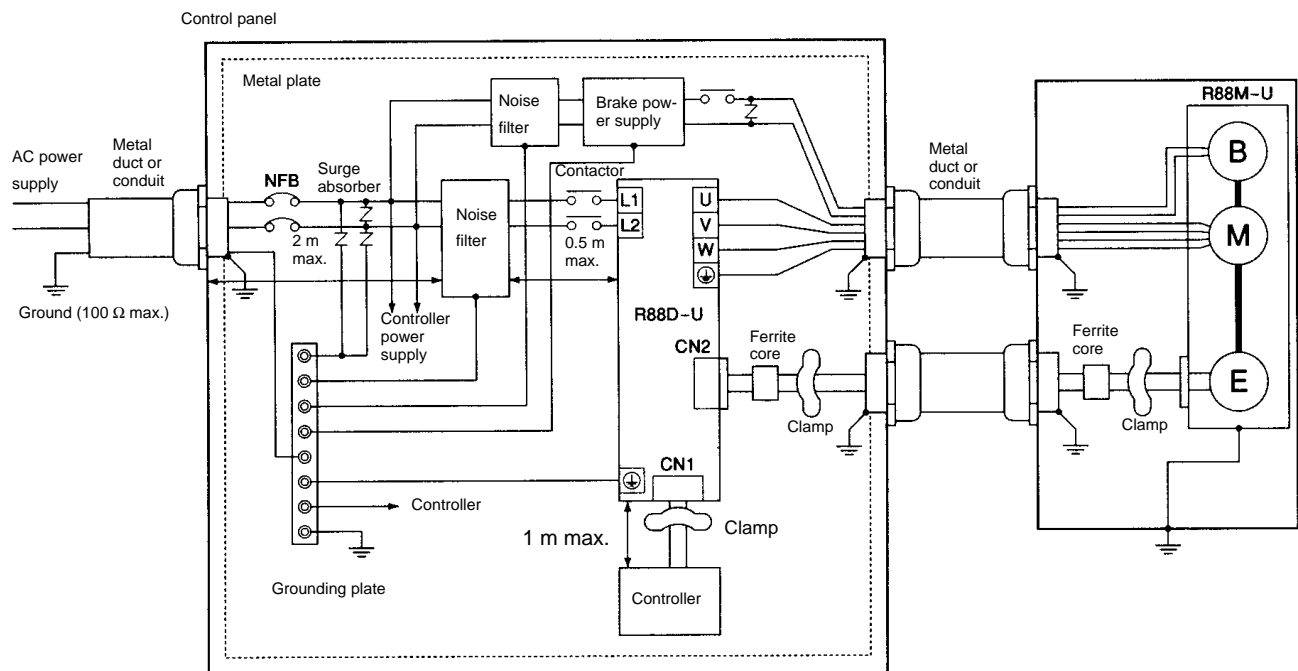

Note 1. The cable winding for the ferrite core must be 1.5 turns.

Note 2. Remove the sheath from the cable and ground it directly to the metal plate at the clamps.

- Ground the motor's frame to the machine ground when the motor is on a movable shaft.
- Use the grounding plate for the protective earth for each Unit, as shown in the illustration, and ground to a single point.
- Use ground lines with a minimum thickness of 3.5 mm², and arrange the wiring so that the ground lines are as short as possible.
- If no-fuse breakers (MCCB) are installed at the top and the power supply line is wired from the lower duct, use metal tubes for wiring and make sure that there is adequate distance between the input lines and the internal wiring. If input and output lines are wired together, noise resistance will decrease.

- No-fuse breakers (MCCB), surge absorbers, and noise filters (NF) should be positioned near the input terminal block (ground plate), and I/O lines should be isolated and wired using the shortest means possible.
- Wire the noise filter as shown at the left in the following illustration. The noise filter should be installed at the entrance to the control panel whenever possible.

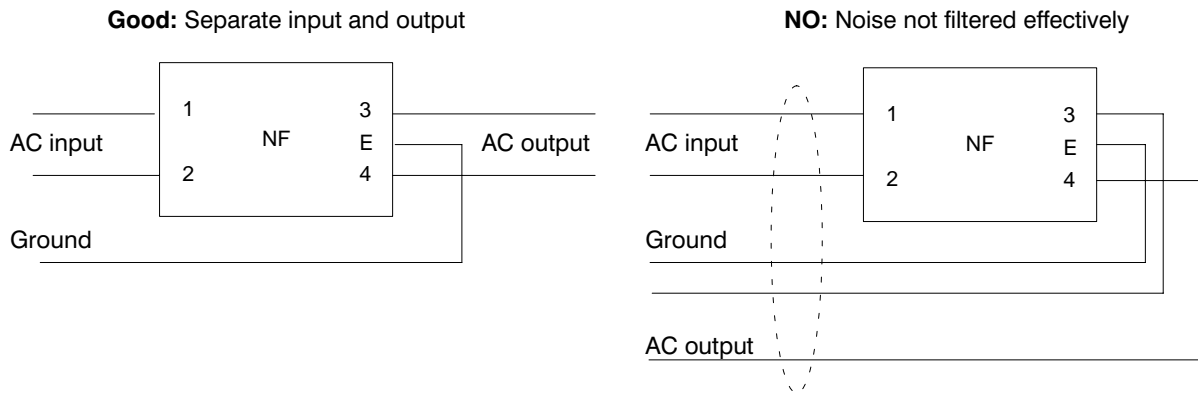

- Use twisted-pair cables for the power supply cables whenever possible, or bind the cables.

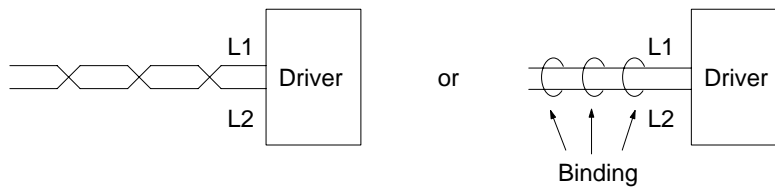

- Separate power supply cables and signal cables when wiring.

☐ Control Panel Structure

Any gaps in the cable entrances, mounting screws, cover, or other parts of a control panel can allow electric waves to leak from or enter the control panel. The items described in this section must be abided by in panel design and selection to ensure that electric waves cannot leak or enter the control panel.

Case Structure

- Use a metal control panel with welded joints on the top, bottom, and all sides. The case must be electrically conductive.
- When assembling the control panel, remove the coating from all joints (or mask the joints when coating) to ensure electrical conductivity.
- Be sure that no gaps are created when installing the control panel, as gaps can be caused by distortion when tightening screws.
- Be sure there are not any electrically conductive parts that are not in electrical contact.
- Ground all Units mounted in the control panel to the panel case.

Cover Structure

- Use a metal cover.
- Use a water-proof structure, as shown in the following diagram, and be sure there are no gaps.
- Use electrically conductive packing between the cover and the case, as shown in the following diagram. (Remove the coating the contact points of the packing (or mask the contact points when coating) to ensure electrical conductivity.)

- Be sure that no gaps are created when installing the cover, as gaps can be caused by distortion when tightening screws.

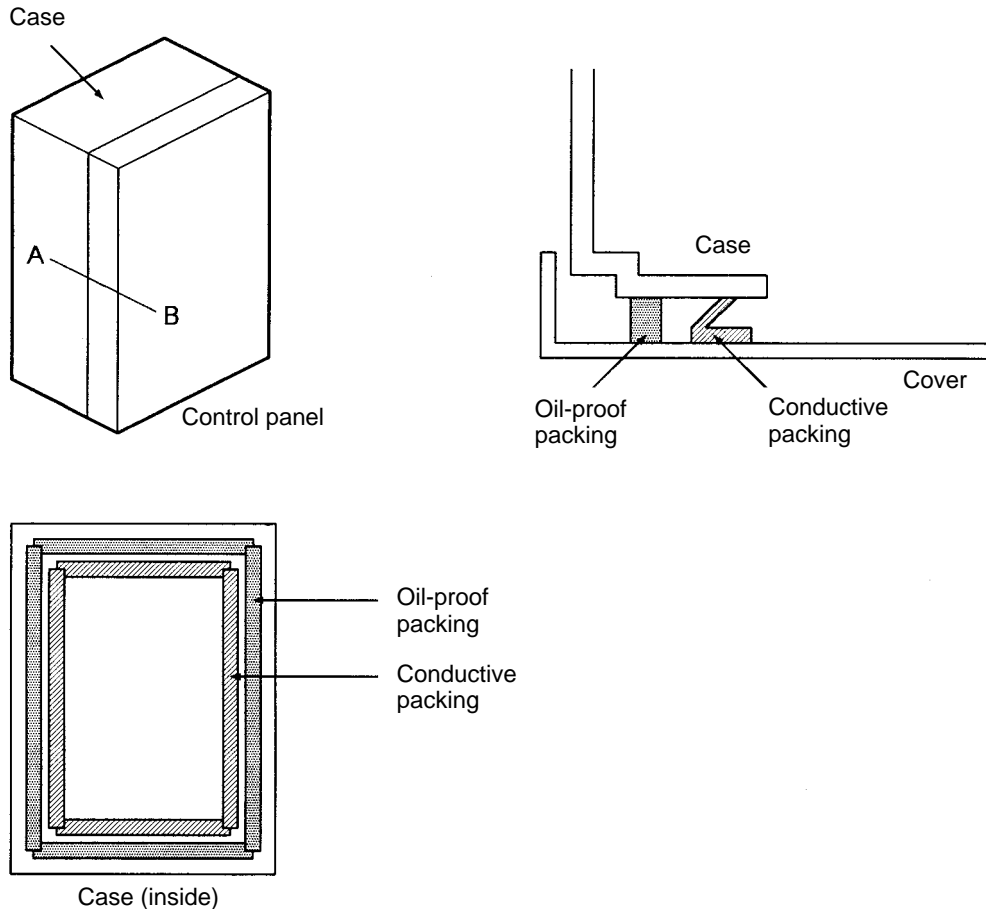

□ Selecting Components

No-fuse Breakers (MCCB)

When selecting no-fuse breakers, take into consideration the maximum output current and the inrush current. The momentary maximum output for a servo system is approximately three times that of the rated output, and a maximum output of three seconds can be executed. Therefore, select no-fuse breakers with an operating time of at least five seconds at 300% of the rated maximum output. General-purpose and low-speed no-fuse breakers are generally suitable. Refer to the table in *2-2-3 Terminal Block Wiring* for the power supply input currents for each motor, and then add the current consumption for the number of shafts, other controllers, etc., to make the selection.

The Servo Driver inrush current flows at a maximum of 50 A for 20 ms when 200 V is input. With low-speed no-fuse breakers, a inrush current 7 to 8 times the rated current flows for 0.1 second. When making the selection, take into consideration the entire inrush current for the system.

Surge Absorbers

Use surge absorbers to absorb surges from power supply input lines due to lightning, abnormal voltages, etc. When selecting surge absorbers, take into account the varistor voltage, the amount of surge immunity, and the amount of energy resistance. For 200-VAC systems, use a varistor voltage of 470 V. The surge absorbers shown in the following table are recommended.

Maker	Model	Max. limit voltage	Surge immunity	Type	Remarks
Okaya Electric Ind.	R.A.V-781BYZ-2	783 V	1,000 A	Block	For power supply line
	R.A.V-781BXZ-4	783 V	1,000 A		For power supply line ground

Note 1. Refer to manufacturers documentation for operating details.

Note 2. The surge immunity is for a standard impulse current of 8/20 μs. If pulses are wide, either decrease the current or change to a larger-capacity surge absorber.

Noise Filters

Use the following noise filters on the power supplies for the Servo Driver and brake. These filters are manufactured by Okaya Electric Ind.

Application	Model	Rated current	Test voltage	Insulation resistance	Leakage current (max.)	Attenuation characteristic	
						Normal (MHz)	Common (MHz)
200 V, 30 to 100 W 100 V, 30 or 50 W Brake power supply	SUP-P5H-EPR-4	5 A	Between terminals: 1,250 V rms, 50/60 Hz, 60 s	Between terminals and case: 6,000 MΩ min. (at 500 VDC)	0.6 mA (at 250 V rms 60 Hz)	0.5 to 30	0.2 to 30
200 V, 200 or 400 W 100 V, 100 W	SUP-P8H-EPR-4	8 A	Between terminals and case: 2,000 V rms, 50/60 Hz, 60 s			0.6 to 30	0.3 to 30
200 V, 750 W 100 V, 200 or 300W	SUP-P10H-EPR-4	10 A				0.7 to 30	0.4 to 30

The appearance of the noise filters is shown below. Screw terminals are used.

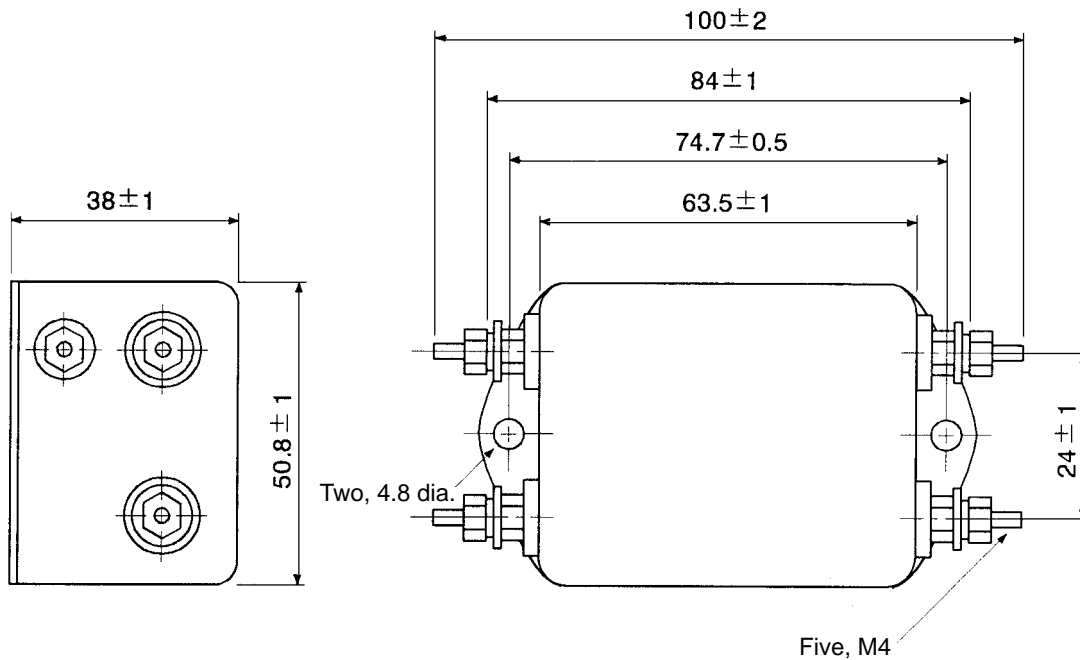

Surge Killers

Install surge killers for loads that have induction coils, such as relays, solenoids, brakes, clutches, etc. The following table shows types of surge killers and recommended products.

Type	Features	Recommended products
Diode	Diodes are relatively small devices such as relays used for loads when reset time is not an issue. The reset time is increased because the surge voltage is the lowest when power is cut off. Used for 24/48-VDC systems.	Use a fast-recovery diode with a short reverse recovery time. Fuji Electric Co., ERB44-06 or equivalent
Thyristor or Varistor	Thyristor and varistor are used for loads when induction coils are large, as in electromagnetic brakes, solenoids, etc., and when reset time is an issue. The surge voltage when power is cut off is approximately 1.5 times that of the varistor.	Select varistor voltage as follows: 24-VDC system varistor: 39 V 100-VDC system varistor: 200 V 100-VAC system varistor: 270 V 200-VAC system varistor: 470 V
Capacitor + resistor	Use capacitors and resistors for vibration absorption of surge when power is cut off. The reset time can be shortened by proper selection of the capacitor or resistor.	Okaya Electric Ind. CR-50500 0.5 μF-50 Ω CRE-50500 0.5 μF-50 Ω S2-A-0 0.2 μF-500 Ω

Note Thyristors and varistors are made by the following companies. Refer to manufacturers documentation for operating details. Thyristors: Ishizuka Electronics Co.
Varistors: Ishizuka Electronics Co., Matsushita Electric Parts

Contactors

When selecting contactors, take into consideration the circuit's inrush current and the momentary maximum current. The Servo Driver inrush current is 50 A, and the momentary maximum current is approximately twice the rated current. The following table shows the recommended contactors.

Maker	Model	Rated current	Momentary maximum current	Coil voltage
OMRON	J7AN-E3	15 A	120 A	24 VDC

Leakage Breakers

- Select leakage breakers designed for inverters.
- Since switching operations take place inside the Servo Driver, high-frequency current leaks from the armature of the Servomotor. With inverter leakage breakers, high-frequency current is not detected, preventing the breaker from operating due to leakage current.
- When selecting leakage breakers, also remember to add the leakage current from devices other than the Servomotor, such as machines using a switching power supply, noise filters, inverters, and so on.
- For detailed information about the selection methods of leakage breakers, refer to catalogs provided by manufacturers.
- The following table shows the Servomotor leakage currents for each Servo Driver.

Driver	Leakage current (direct) (including high-frequency current)	Leakage current (resistor-capacitor, in commercial power supply frequency range)
R88D-UA02V to -UA08V	80 mA	3 mA
R88D-UA12V	60 mA	4 mA
R88D-UA20V	110 mA	5 mA

Note 1. Leakage current values shown above are for motor power lines of 10 m or less. The values will change depending on the length of power cables and the insulation.

Note 2. Leakage current values shown above are for normal temperatures and humidity. The values will change depending on the temperature and humidity.

Note 3. Leakage current for 100-VAC-input Servomotors is approximately half that of the values shown above.

□ Improving Encoder Cable Noise Resistance

The following encoder signals are used: A, B, and S phase. The frequency for A- or B-phase signals is 154 kHz max.; the transmission speed for S-phase signals is 616 kbps.

Follow the wiring methods outlined below to improve encoder noise resistance.

- Be sure to use dedicated encoder cables.
- If lines are interrupted in the middle, be sure to connect them with connectors, making sure that the cable insulation is not peeled off for more than 50 mm. In addition, be sure to use shielded wire.
- Do not coil cables. If cables are long and are coiled, mutual induction and inductance will increase and will cause malfunctions. Be sure to use cables fully extended.
- When installing noise filters for encoder cables, use ferrite cores. The following table shows the recommended ferrite core models.

Maker	Name	Model
Token	EMI core	ESD-QR-25-1
TDK	Clamp filter	ZCAT2032-0930
		ZCAT3035-1330
		ZCAT2035-0930A

- Do not wire the encoder cable in the same duct as power cables and control cables for brakes, solenoids, clutches, and valves.

□ Improving Control I/O Signal Noise Resistance

Position can be affected if control I/O signals are influenced by noise. Follow the methods outlined below for the power supply and wiring.

- Use completely separate power supplies for the control power supply (especially 24 VDC) and the external operation power supply. In particular, be careful not to connect two power supply ground wires. Install a noise filter on the primary side of the control power supply.
- For speed and torque command input lines, be sure to use twisted-pair shielded cable, and connect both ends of the shield wire to ground.
- If the control power supply wiring is long, noise resistance can be improved by adding 1- μ F laminated ceramic capacitors between the control power supply and ground at the Servo Driver input section and the controller output section.
- For encoder output (A, B, and Z phase, plus the absolute encoder signal) lines, be sure to use twisted-pair shielded cable, and connect both ends of the shield wire to ground.

2-3-4 Peripheral Device Connection Examples

□ Connecting to Peripheral Devices

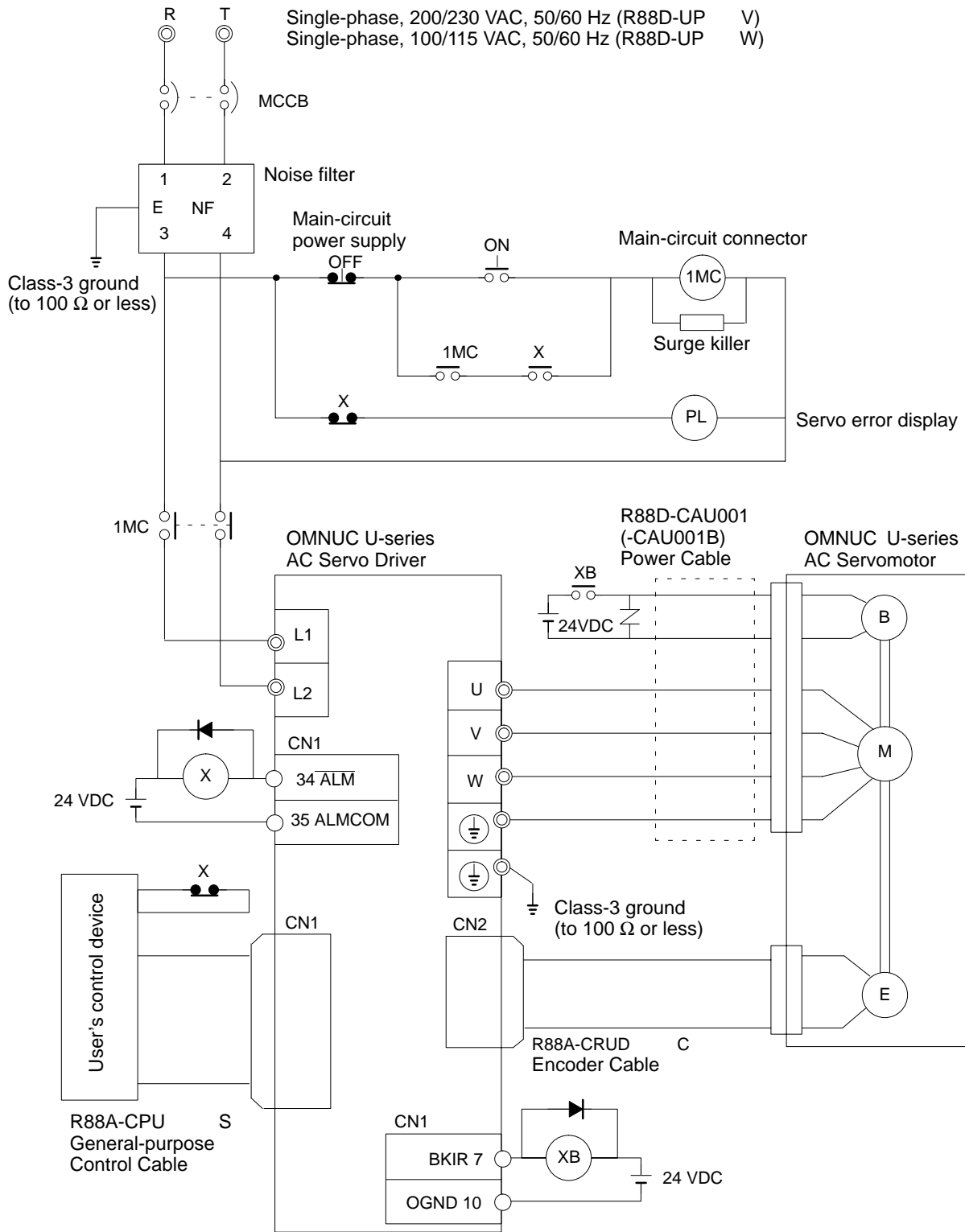

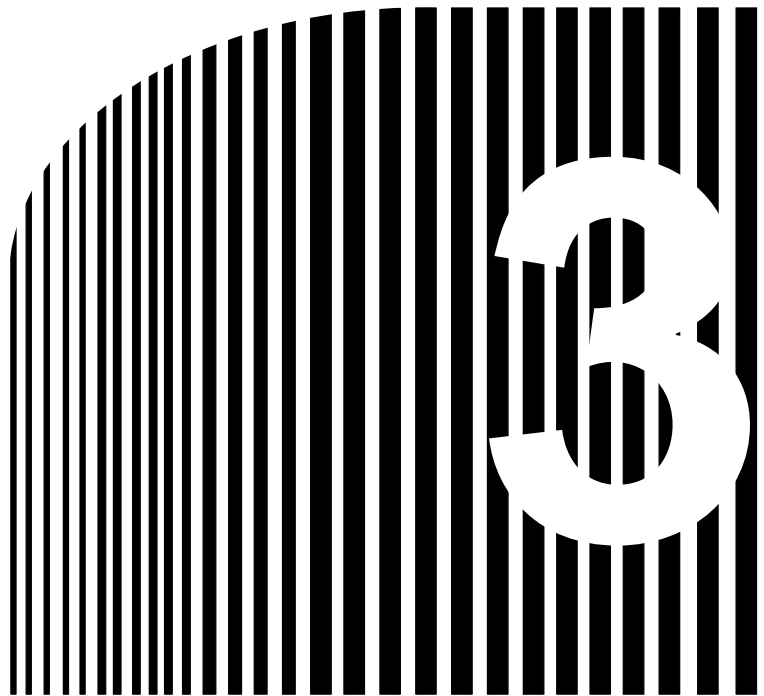



Chapter 3

• Operation •

- 3-1 Operational Procedure
- 3-2 Turning On Power and Checking Displays
- 3-3 Using Parameter Units
- 3-4 Initial Settings: Setup Parameters
- 3-5 Setting Functions: User Parameters
- 3-6 Trial Operation
- 3-7 Making Adjustments
- 3-8 Regenerative Energy Absorption

Operation and Adjustment Precautions

-  **Caution** Check the newly set parameters for proper execution before actually running them. Not doing so may result in equipment damage.

-  **Caution** Do not make any extreme adjustments or setting changes. Doing so may result in unstable operation and injury.

-  **Caution** Separate the Servomotor from the machine, check for proper operation, and then connect to the machine. Not doing so may cause injury.

-  **Caution** When an alarm occurs, remove the cause, reset the alarm after confirming safety, and then resume operation. Not doing so may result in injury.

-  **Caution** Do not come close to the machine immediately after resetting momentary power interruption to avoid an unexpected restart. (Take appropriate measures to secure safety against an unexpected restart.) Doing so may result in injury.

-  **Caution** Do not use the built-in brake of the Servomotor for ordinary braking. Doing so may result in malfunction.

3-1 Operational Procedure

After confirming that the system has been correctly installed and wired, make the initial settings for the Servo Driver. Then, set the functions as required for the application of the Servomotor.

Any incorrect settings in the parameters could cause unexpected motor operation, creating an extremely dangerous situation. Use the procedures provided in this section to carefully set all parameters.

Startup Procedure

1. Mounting and Installation

Install the Servomotor and Servo Driver according to the installation conditions: **Chapter 2, section 2-1.**

2. Wiring and Connections

Connect to power supply and peripheral devices: **Chapter 2, section 2-2, 2-3.**

The specified installation and wiring conditions are particularly important to ensure that models conforming to EC Directives actually conform to the EC Directive in the final system.

3. Turning on Power Supply

Before turning on the power supply, check the necessary items. In order to make the initial settings, turn on an application power supply: **Chapter 3, section 3-2.**

4. Checking Display Status

Check by means of the displays to see whether there are any internal errors in the Servo Driver: **Chapter 3, section 3-2**

5. Initial Settings

Make the settings for the operation setup parameters (initial settings): **Chapter 3, section 3-4.**

6. Function Settings

By means of the user parameters, set the functions according to the operating conditions: **Chapter 3, section 3-5.**

7. Trial Operation

Before performing trial operation, turn the power supply off and then back on so that any parameters that have been set will be valid.

Check to see whether protective functions such as emergency stop and operational limits are working reliably. Check operation at both low speed and high speed: **Chapter 3, section 3-6.**

8. Adjustments

Execute auto-tuning. Manually adjust the gain as required: **Chapter 3, section 3-7.**

9. Operation

Operation can now begin. If any trouble should occur, refer to *Chapter 4 Applications*: **Chapter 4.**

3-2 Turning On Power and Checking Displays

3-2-1 Items to Check Before Turning On Power

Checking Power Supply Voltage

- Check to be sure that the power supply voltage is within the ranges shown below.

R88D-UP H(A) (200 VAC specifications): Single-phase 200/230 VAC (170 to 253 V) 50/60 Hz

R88D-UP L(A) (100 VAC specifications): Single-phase 100/115 VAC (85 to 127 V) 50/60 Hz

R88D-UP V (200 VAC specifications): Single-phase 200/230 VAC (170 to 253 V) 50/60 Hz

R88D-UP W (100 VAC specifications): Single-phase 100/115 VAC (85 to 127 V) 50/60 Hz

Checking Terminal Block Wiring

- The power supply inputs R and T, or L1 and L2, must be properly connected to the terminal block.
- The Servomotor's red (U), white (V), and blue (W) power lines and the green ground wire (⏚) must be properly connected to the terminal block.

Checking the Servomotor

- There should be no load on the Servomotor. (Do not connect to the mechanical system.)
- The power lines and power cables must be securely connected at the Servomotor.

Checking the Encoder Connectors

- The encoder connectors (CN2) at the Servo Driver must be securely connected.
- The encoder connectors at the Servomotor must be securely connected.

Checking the Control Connectors

- The control connectors must be securely connected.
- The Run command must be OFF.

Checking the Parameter Unit Connection

- The Parameter Unit (R88A-PR02U or R88A-PR03U) must be securely connected to connector CN3.

3-2-2 Turning On Power and Confirming the Display

Turning On Power

- Confirm that it is safe to turn on the power supply and then turn on the power supply.

Checking Displays

- When the power is turned on, one of the codes shown below will be displayed.

Normal (Base block)	Error (Alarm Display)										
<table border="1" style="display: inline-table; border-collapse: collapse;"> <tr> <td style="width: 20px; height: 20px; text-align: center;">-</td> <td style="width: 20px; height: 20px;"></td> <td style="width: 20px; height: 20px;"></td> <td style="width: 20px; height: 20px; text-align: center;">b</td> <td style="width: 20px; height: 20px; text-align: center;">b</td> </tr> </table>	-			b	b	<table border="1" style="display: inline-table; border-collapse: collapse;"> <tr> <td style="width: 20px; height: 20px; text-align: center;">-</td> <td style="width: 20px; height: 20px;"></td> <td style="width: 20px; height: 20px; text-align: center;">A.</td> <td style="width: 20px; height: 20px; text-align: center;">0</td> <td style="width: 20px; height: 20px; text-align: center;">2</td> </tr> </table>	-		A.	0	2
-			b	b							
-		A.	0	2							

Note 1. "Base block" means that the Servomotor is not receiving power.

Note 2. The alarm code (the number shown in the alarm display) changes depending on the contents of the error.

- If the display is normal (i.e., no errors), use it as a monitor mode speed display. Manually turn the Servomotor shaft clockwise and counterclockwise, and check to be sure that it agrees with the positive and negative on the speed display. If it does not agree, then the encoder signal line may be wired incorrectly. Check the conductivity of the cable by itself.

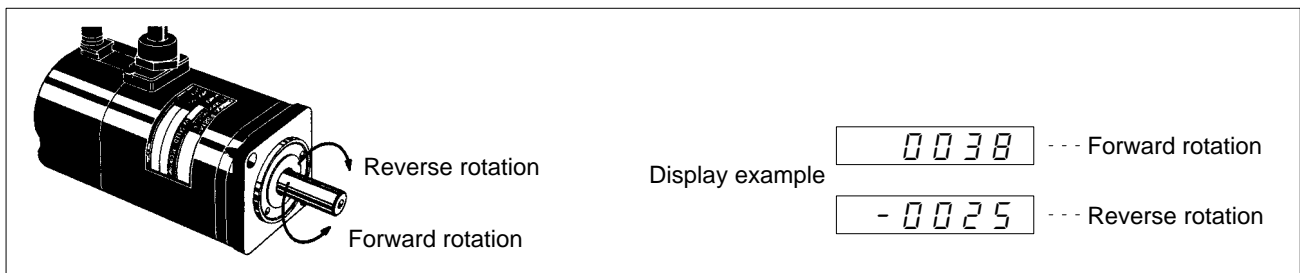

Note To monitor the speed feedback value, press the MODE/SET Key and go into monitor mode

U n - 00. Then press the DATA Key.

- If there is an error, refer to *Chapter 4 Application* and take the necessary countermeasures.

3-3 Using Parameter Units

The key operations for the Hand-held R88A-PR02U Parameter Unit and the Mounted R88A-PR03U Parameter Unit vary depending on the functions used.

3-3-1 Parameter Unit Keys and Functions

Hand-held
Parameter Unit
R88A-PR02U

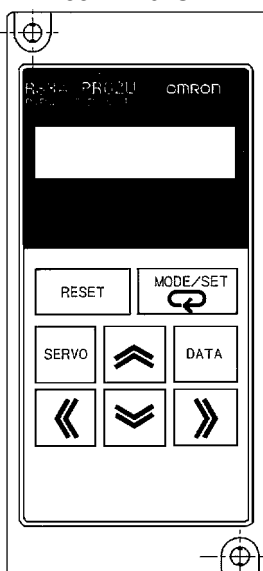

Mounted
Parameter Unit
R88A-PR03U

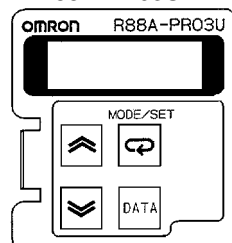

PR02U	PR03U	Function
RESET	⏴ + ⏵	Alarm reset
↻	↻	Mode switching Data memory
SERVO	DATA	Servo ON/OFF during jog operations
DATA	DATA	Switching between parameter display and data display; data memory
⏴	⏴	Increments parameter numbers and data values.
⏵	⏵	Decrements parameter numbers and data values.
⏪	---	Left shift for operation digits
⏩	---	Right shift for operation digits

3-3-2 Modes and Changing Modes

□ Modes

OMNUC U-series AC Servo Drivers have four operating modes, as described in the following table. For example, the Settings Mode is used to set parameters.

Mode	Function
Status display mode	Bit display (indicating internal status via indicators): Power supply ON display, base block, positioning completion, rotation detection and current limit detection, command pulse input Symbol display (indicating internal status via 3-digit 7-segment display): Base block, operating, forward rotation prohibited, reverse rotation prohibited, alarm display
Settings mode	System check: Jog operations, alarm history data clear, motor parameters check, auto-tuning Setting and checking setup parameters Setting and checking user parameters
Monitor mode	Speed feedback, speed commands, torque commands, number of pulses from U-phase, electrical angle, internal status bit display, command pulse speed display, position deviation, input pulse counter (HA/LA/V/W Models)
Alarm history display mode	Displays contents of alarms that have been previously generated (up to a maximum of 10).

□ Changing Modes

To change modes, press the MODE/SET Key.

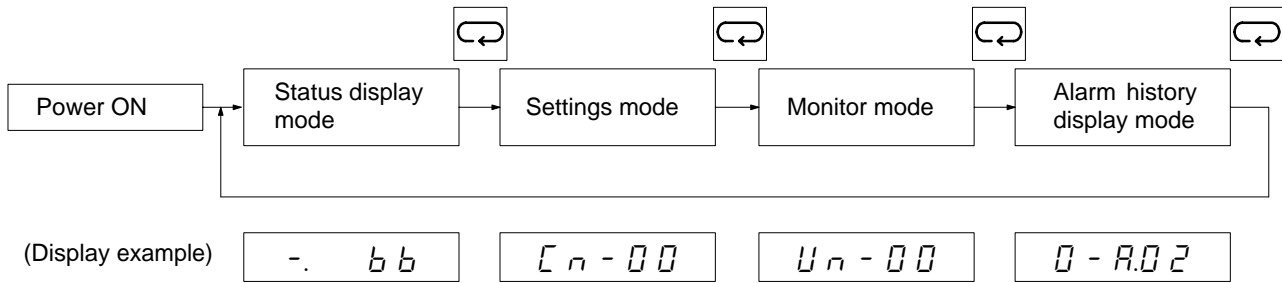

3-3-3 Mode Changes and Display Contents

The following diagram shows the functions and references for each mode.

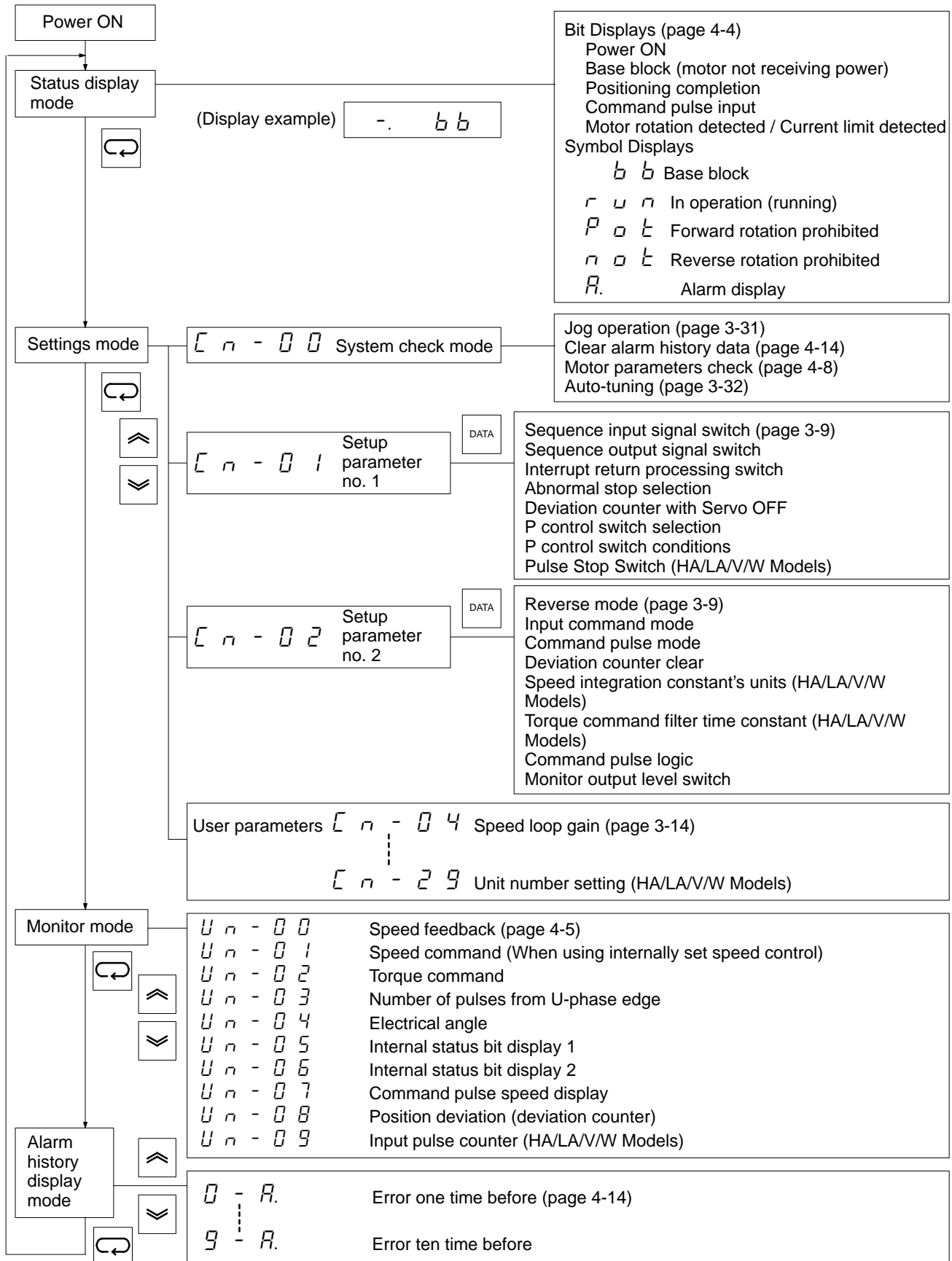

3-4 Initial Settings: Setup Parameters

Setup parameters are parameters that are essential for starting up the system. They include I/O signal function changes, selection of processing for momentary stops and errors, command pulse modes, and so on. Set them to match the user system.

Once the parameters have been set, they become effective when the power supply is turned on again after having been turned off. (Check to see that the LED display has gone off.)

3-4-1 Setting and Checking Setup Parameters (Cn-01, 02)

□ Displaying Setup Parameters

There are two setup parameters: No. 1 (Cn-01) and No. 2 (Cn-02).

To display the contents of setup parameters, execute the following key operations.

1. To go into settings mode (Cn-00), press the MODE/SET Key.
2. To display the setup parameter number (Cn-01 or Cn-02), press the Up and Down keys.
3. To display the contents of the setup parameter, press the DATA key.

To display the setting of setup parameter No. 2, press the Up Key twice at step 2. before pressing the DATA Key.

The contents of the setup parameters are displayed as follows:

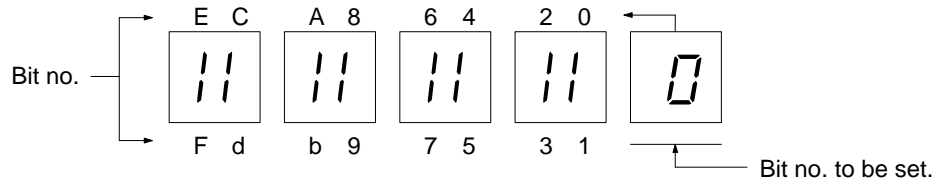

In the leftmost four digits, 16 bits of information are displayed. In the rightmost digit, the bit number that can be set is displayed. It can be checked whether the bit information is “0” (not lit) or “1” (lit), according to the 7-segment display vertical bar. To change the set value, first set the bit number in the rightmost digit, and then set the appropriate bit to “0” or “1.”

□ Setting Setup Parameters

First, display the setting of the setup parameter (No. 1 or No. 2) using the procedure given above. To change a setting, specify the bit to be changed and then set it to “1” or “0.”

Making Settings with Hand-held Parameter Unit (R88A-PR02U)

1. Use the Right and Left Keys to display in the rightmost digit the bit number that is to be set.
2. Using the Up (or Down) Key, reverse the lit/not lit status of the appropriate bit number. For “lit,” set the bit number to “1.” For “not lit,” set it to “0.”
3. Repeat steps 1 and 2 above as required.
4. Save the data in memory by pressing the MODE/SET Key (or the DATA Key).
5. With this, the parameter setting operation is complete. Pressing the DATA Key at this point will bring back the parameter number display.

Making Settings with Mounted Parameter Unit (R88A-PR03U)

1. Use the Up and Down Keys to display in the rightmost digit the bit number that is to be set.
2. Using the MODE/SET Key, reverse the lit/not lit status of the appropriate bit number. For “lit,” set the bit number to “1.” For “not lit,” set it to “0.”

3. Repeat steps 1 and 2 above as required.
4. Save the data in memory by pressing the DATA Key.
5. With this, the parameter setting operation is complete. Pressing the DATA Key at this point will bring back the parameter number display.

3-4-2 Setup Parameter Contents

Setup Parameter No. 1 (Cn-01)

Item	Bit no.	Factory setting	Setting	Explanation	
Sequence input signal switching	0	0	0	Servo turned ON or OFF by Run command (externally input).	
			1	Servo always ON.	
	1	0	---	Not used.	
	2	1	0	Enables forward drive prohibit input (POT).	
			1	Permits always-forward drive.	
	3	1	0	Enables reverse drive prohibit input (NOT).	
1			Permits always -reverse drive.		
Sequence output signal switching	4	0	0	Takes TGON/CLIMT signal as motor rotation detection output.	
			1	Takes TGON/CLIMT signal as current limit detection output.	
Processing at time of recovery from momentary stop	5 (see note 1)	1	0	Servo alarm set at time of recovery from momentary stop.	
			1	Servo alarm automatically cleared at time of recovery from momentary stop.	
Abnormal stop	6	1	0	Motor stopped by dynamic brake.	
			1	Motor stopped with free run.	
	7 (see note 2)	1	0	Dynamic brake OFF after motor stopped.	
			1	Dynamic brake ON after motor stopped.	
	8	0	0	Method for stopping when over-travel occurs depends on bit no. 6 setting.	
			1	When over-travel occurs, motor is stopped at the torque set by user parameter Cn-06 (emergency stop torque).	
	9	0	0	When over-travel occurs, motor comes to deceleration stop and servo turns OFF.	
			1	When over-travel occurs, motor comes to deceleration stop and position is locked. (see note 6)	
	Deviation counter with Servo OFF	A	0	0	Clear counter for alarms occurring while Servo is OFF
				1	Do not clear counter for alarms occurring while Servo is OFF
P control switch selection	b	1	0	Switch control according to bits C and d.	
			1	Do not switch	
P control switch conditions	d, C (see note 3)	0, 0	0, 0	The torque command value (Cn-0C) is taken as the condition.	
			0, 1	The speed command value (Cn-0d) is taken as the condition.	
			1, 0	The acceleration command value (Cn-0E) is taken as the condition.	
			1, 1	The deviation pulse (Cn-0F) is taken as the condition.	
	E	0	---	Not used.	

Item	Bit no.	Factory setting	Setting	Explanation
Pulse stop switching (HA/LA/V/W Models)	F	0	0	Position Control (when bit 2 of Cn-02 is 0) Disables the pulse stop input. (CN1-15 is the gain reduction (MING).) Internal speed control settings (when bit 2 of Cn-02 is 1) Command pulses aren't received when PCL and NCL are OFF.
			1	Position Control (when bit 2 of Cn-02 is 0) Enables the pulse stop input. (CN1-15 is the pulse stop input (IPG).) Internal speed control settings (when bit 2 of Cn-02 is 1) Command pulses aren't received when PCL and NCL are OFF. (Position control is performed with the internal speed control settings and the pulse-train input.)

Note 1. If power is immediately turned back on after having been cut off, a momentary stop alarm may be generated. If bit no. 5 is set to "1," the alarm will be cleared automatically even if it is generated, and operation will resume.

Note 2. If set bit 6 to "1" and bit 8 to "0," the dynamic brake relay will turn OFF after the Servomotor stops, regardless of the setting of bit no. 7.

Note 3. With P control switch conditions, a change from PI control to P control is selected.

Note 4. Do not set bit nos. 1 and E of setup parameter no. 1 (Cn-01).

Note 5. These parameters become effective only after power is reset. Confirm that the indicators go out before turning power back on. (Check to see that the LED display has gone off)

Note 6. The position loop will not be effective when stopping in this mode.

Setup Parameter No. 2 (Cn-02)

Item	Bit no.	Factory setting	Setting	Explanation
Reverse rotation mode	0	0	0	Rotates in the CCW direction with a + command. (See note 3.)
			1	Rotates in the CW direction with a + command.
	1	0	---	Not used.
Input command mode	2	0	0	Position control with pulse-train input: CN1-11 and 12 are used as forward and reverse current limit inputs (PCL, NCL). In the H/L Models, CN1-15 will be the gain reduction (MING). In the HA/LA/V/W Models, CN1-15 will be the gain reduction (MING) if Cn-01 bit F is set to "0" or the pulse stop input (IPG) if Cn-01 bit F is set to "1."
			1	Internal speed control settings: CN1-11 and 12 are used as speed selection commands 1 and 2 inputs (SPD1, SPD2). CN1-15 will be the rotation direction command (RDIR).
Command pulse mode	5, 4, 3	0, 0, 1	0, 0, 0	Feed pulse and Forward/reverse signal
			0, 0, 1	Forward rotation pulse and Reverse rotation pulse
			0, 1, 0	90° phase difference (A/B phase) signal (1X)
			0, 1, 1	90° phase difference (A/B phase) signal (2X)
			1, 0, 0	90° phase difference (A/B phase) signal (4X)
	6	0	---	Not used.
	7	0	---	Not used.
	8	0	---	Not used.
	9	0	---	Not used.
Deviation counter clear	A	1	0	Clears the deviation counter when the signal is high level
			1	Clears the deviation counter on the rising edge of the signal
Speed integration constant's units (HA/LA/V/W Models)	b	0	0	1 ms
			1	0.01 ms
Torque command filter time constant (HA/LA/V/W Models)	c	0	0	Primary filter
			1	Secondary filter
Command pulse logic reversal	d	0	0	Positive logic
			1	Negative logic
Parameter Unit monitor output lever change	E	0	0	Position deviation monitor set for 1 command.
			1	Position deviation monitor set for 100 commands.
	F	0	---	Not used.

Note 1. Do not set bits number 1, 6 to 9, and F of setup parameter no. 2 (Cn-02).

Note 2. These parameters become effective only after power is reset. Confirm that the indicators go out before turning power back on. (Check to see that the LED display has gone off)

Note 3. Counterclockwise direction when viewed from the motor output shaft is CCW and clockwise direction is CW.

3-4-3 Important Setup Parameters (Cn-01 and Cn-02)

This section explains the particularly important setup parameters. If these parameters aren't set properly, the motor might not operate or might operate unpredictably. Set these parameters appropriately for the system being used.

Control Mode Settings

The control mode is determined by the following setup parameters:

- Input command mode: Cn-02 bit 2 (position control by pulse-train input/internal speed control settings)
- Pulse stop switch: Cn-01 bit F (The function of this bit depends on the setting of Cn-02 bit 2.)

The following diagram shows the function of these two bits:

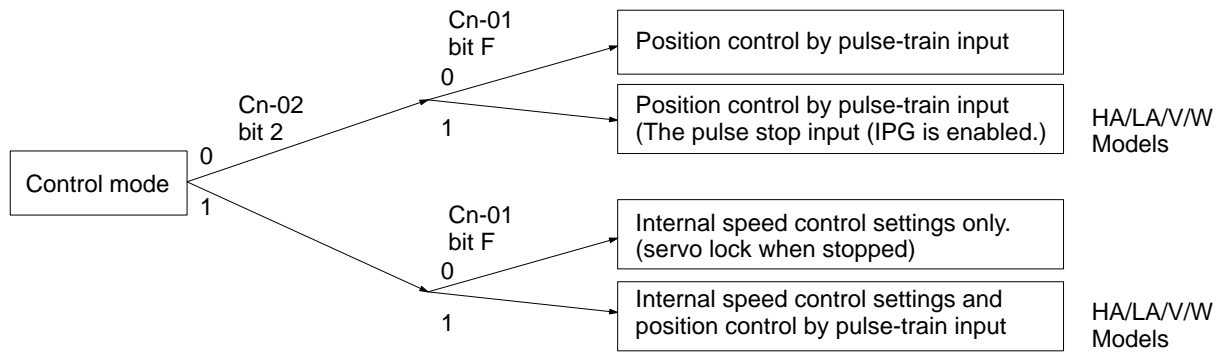

Cn-02 bit 2	Cn-01 bit F	Control mode
0	0	Position control by pulse-train inputs (Factory setting)
	1	Position control by pulse-train inputs (pulse stop input (IPG) enabled)
1	0	Internal speed control settings only. (Servo lock when stopped.)
	1	Internal speed control settings + position control by pulse-train input

Note Cn-01 bit F is effective in the HA/LA/V/W Models only. With H/L Models, use Cn-02 bit 2 to select either “position control by pulse-train inputs” or “internal speed control settings.”

Command Pulses in Position Control

Bits 3, 4, and 5 of Cn-02 specify the kind of command pulse mode used for position control, as shown in the following table.

Cn-02 bit 3	Cn-02 bit 4	Cn-02 bit 5	Selected command pulse mode
0	0	0	Feed pulse (PULS)/Direction signal (SIGN)
1	0	0	Forward pulse (CCW)/Reverse pulse (CW) (Factory setting)
0	1	0	90 differential phase (A/B phase) signal (1×)
1	1	0	90 differential phase (A/B phase) signal (2×)
0	0	1	90 differential phase (A/B phase) signal (4×)

Note One of three multiples can be selected when inputting a 90 differential phase signal (1×, 2×, or 4×). If the 4× multiple is selected, the input pulses are multiplied by a factor of 4, so the number of motor revolutions (speed and angle) are 4 times the number when the 1× multiple is selected.

□ Error Stop Processes

Bits 6, 7, 8, and 9 of Cn-01 specify how the motor will be stopped when the servo goes OFF (the run command is OFF), an alarm is generated, or overtravel occurs. The following diagrams show the function of these four bits:

Stop Process for Servo OFF/Alarm

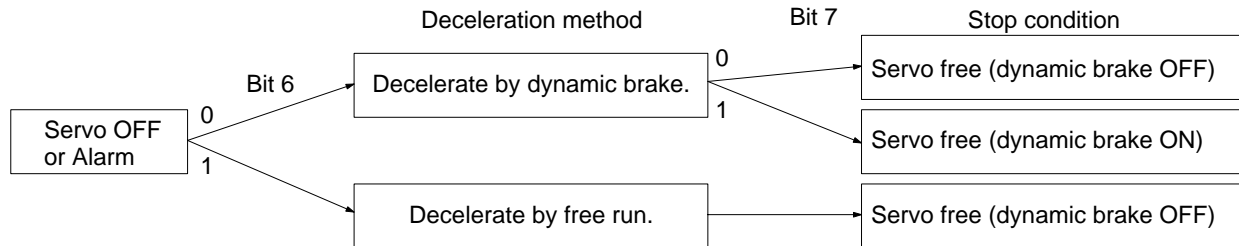

Stop Process for Overtravel

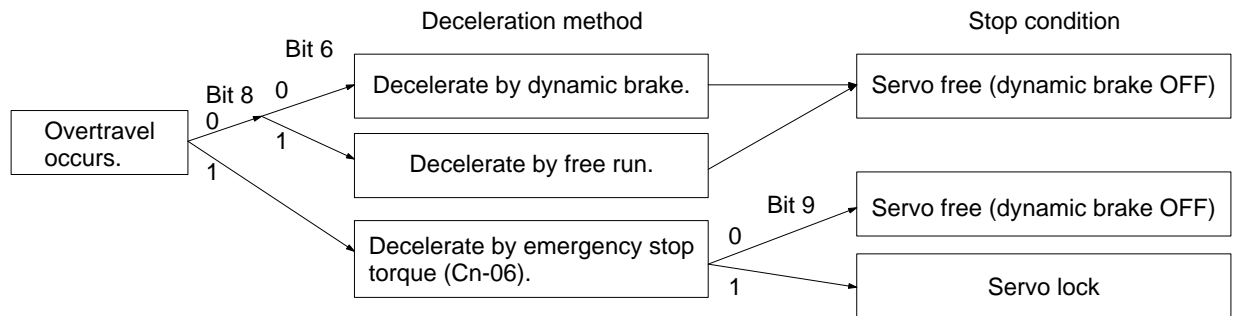

3-5 Setting Functions: User Parameters

Execute the user parameter settings in order as follows:

- Go into settings mode. MODE/SET Key
- Display the pertinent parameter number. Direction Keys (Handy-type)
Up and Down Keys (Mounted-type)
- Display the contents (data) of the parameter. . DATA Key
- Change the data. Direction Keys (Handy-type)
Up and Down Keys (Mounted-type)
- Save the data in memory. MODE/SET and DATA Keys

3-5-1 Setting and Checking User Parameters (Cn-04 to 29)

□ Displaying User Parameters

Perform the following procedures on the Parameter Unit to display the user parameters.

Displaying with Handy-type (R88A-PR02U)

1. Press the MODE/SET Key to go into settings mode ([Cn-]).
2. Press the Direction Keys to display the desired user parameter number.
Press the Right and Left Keys to select the digit to be set. The digit whose value can be set will blink.
Press the Up and Down Keys to increment or decrement the digit.
3. Press the DATA Key to display the setting of the specified parameter.
4. Press the DATA Key again to return to the parameter number display.

Note If only the Up or Down Key is pressed at step 2., the parameter number can be set directly. In this case, the rightmost digit will blink. The number cannot be set if the second digit (the 10s digit) is blinking (i.e., blinking indicates the digit that can be changed).

Displaying with Mounted-type (R88A-PR03U)

1. Press the MODE/SET Key to go into settings mode ([Cn-]).
2. Press the Up and Down Keys to display the desired user parameter number.
The number will be incremented or decremented each time the Up or Down Key is pressed.
3. Press the DATA Key to display the setting of the specified parameter.
4. Press the DATA Key again to return to the parameter number display.

Parameter Display Example

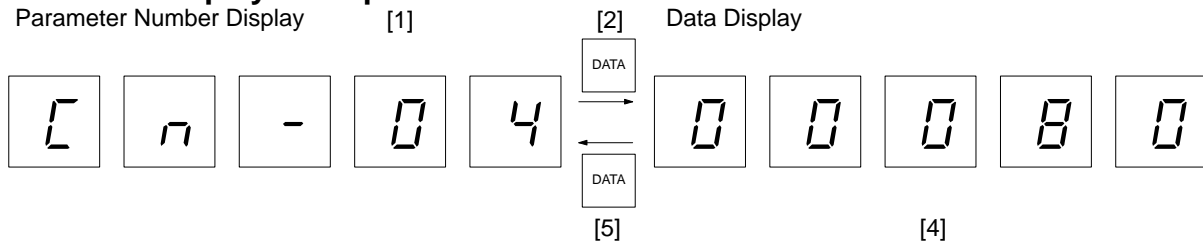

□ Setting User Parameters

First, use the previous procedure to display the settings of the user parameter. Then use the following procedures to set user parameters.

Making Settings with Handy-type (R88A-PR02U)

1. Use the Right and Left Keys to select the digit that is to be set. The digit for which the value can be changed will blink.
2. Press the Up and Down Keys to change the value of the digit.
3. Repeat the previous two steps as required to set the parameter.
4. Press the MODE/SET or DATA Key. The parameter will be set and the display will blink.
5. Press the DATA Key again to return to the parameter number display.

6. Repeat steps 1 through 5 above as required to set other parameters.

Note 1. Settings can also be made by pressing only the Up and Down Keys in stead of using steps 1. and 2. This will enable setting digits higher than the one that is blinking. Use whichever method is faster for the number of digits that need to be set.

Note 2. The Down Key can be pressed when all digits higher than the blinking one are zeros to set the minimum value in the setting range.

Note 3. The fifth digit (i.e., the leftmost digit) cannot be made to blink by pressing the Left Key. The fifth digit can be set from the fourth digit. For example, to set “10000,” press the Left Key to make the fourth digit blink and then press the Up Key again once the fourth digit reaches “9.” The fifth digit will change to “1” and the fourth digit will change to “0.”

Making Settings with Mounted-type (R88A-PR03U)

1. Using the Up and Down Keys, set the data. If the keys are held down, the numbers will change 10 at a time. If the keys are held down even longer, the numbers will change 100 and then 1,000 at a time.
2. Press the MODE/SET Key (or the DATA Key). The parameter will be set and the display will blink.
3. Pressing the DATA Key again will bring back the parameter number display.
4. Repeat steps 1 through 4 above as required to set other parameters.

3-5-2 User Parameter Chart

PRM No.	Parameter name	Factory setting	Unit	Setting range	Explanation
Cn-00	System check mode	---	---	---	Refer to system check mode explanation.
Cn-01	Setup parameter no. 1	---	---	---	Refer to setup parameter no. 1 explanation.
Cn-02	Setup parameter no. 2	---	---	---	Refer to setup parameter no. 2 explanation.
Cn-04	Speed loop gain (See note 1.)	80	Hz	1 to 2,000	Adjusts speed loop response.
Cn-05	Speed loop integration constant	20	ms	2 to 10,000	Speed loop integration const. With the HA/LA/V/W Models, the units can be set with bit b of Cn-02. Bit b=0: 1-ms units Bit b=1: 0.01-ms units
Cn-06	Emergency stop torque	Maximum torque	%	0 to maximum torque	Deceleration torque when abnormality occurs (compared to rated torque).
Cn-07	Software start acceleration time	0	ms	0 to 10,000	Acceleration time setting for software start.
Cn-08	Forward torque limit	Maximum torque	%	0 to maximum torque	Output torque for rotation in forward direction (compared to rated torque).
Cn-09	Reverse torque limit	Maximum torque	%	0 to maximum torque	Output torque for rotation in reverse direction (compared to rated torque).
Cn-0A	Encoder divider rate (See note 2.)	1,000	Pulses/revolution	16 to 2,048	Setting for number of output pulses from Servo Driver.

PRM No.	Parameter name	Factory setting	Unit	Setting range	Explanation
Cn-0b	Rotational speed for motor rotation detection	20	r/min	1 to 4,500	Setting for rotational speed for motor rotor detection output.
Cn-0C	P control switching (torque commands)	200	%	0 to maximum torque	If a torque command exceeds this value, the mode switches from PI to P control.
Cn-0d	P control switching (speed commands)	0	r/min	0 to 4,500	If a speed command exceeds this value, the mode switches from PI to P control.
Cn-0E	P control switching (acceleration commands)	0	10 (r/min)/s	0 to 3,000	If an acceleration command exceeds this value, the mode switches from PI to P control.
Cn-0F	P control switching (deviation pulse)	10	Command units	0 to 1,000	If the deviation pulse exceeds this value, the mode switches from PI to P control.
Cn-10	Jog speed	500	r/min	0 to 4,500	Setting for manual rotational speed
Cn-11	Number of encoder pulses (See notes 2 and 3.)	2,048	Pulses/revolution	2,048	Setting for number of pulses for encoder used.
Cn-12	Brake timing 1	0	10 ms	0 to 50	Delay time setting from brake command until servo turns off.
Cn-15	Brake command speed	100	r/min	0 to 4,500	Sets rotational speed for outputting brake commands.
Cn-16	Brake timing 2	50	10 ms	10 to 100	Waiting time from servo-off to brake command output.
Cn-17	Torque command filter time constant	4	100 μ s	0 to 250	Setting for torque command filter time constant (6.4 to 398 Hz).
Cn-18	Forward rotation external current limit	100	%	0 to maximum torque	Output torque for when forward rotation current limit is input (compared to rated torque).
Cn-19	Reverse rotation external current limit	100	%	0 to maximum torque	Output torque for when reverse rotation current limit is input (compared to rated torque).
Cn-1A	Position loop gain	40	1/s	1 to 500	For position loop response adjustment.
Cn-1b	Positioning completion range	3	Command units	0 to 250	Sets the range for the positioning completion signal output.
Cn-1C	Bias rotational speed	0	r/min	0 to 450	Sets the bias for position control.
Cn-1d	Feed-forward amount	0	%	0 to 100	Position control feed-forward compensation.
Cn-1E	Deviation counter overflow level	1,024	\times 256 commands	1 to 32,767	Sets the level for detection of deviation counter overflow.
Cn-1F	No. 1 internal speed setting	100	r/min	0 to 4,500	Rotational speed, no. 1 internal setting
Cn-20	No. 2 internal speed setting	200	r/min	0 to 4,500	Rotational speed, no. 2 internal setting
Cn-21	No. 3 internal speed setting	300	r/min	0 to 4,500	Rotational speed, no. 3 internal setting

PRM No.	Parameter name	Factory setting	Unit	Setting range	Explanation
Cn-23	Software start deceleration time	0	ms	0 to 10,000	Sets the deceleration time for software starts.
Cn-24	Electronic gear ratio G1 (numerator) (see note 2)	4	---	1 to 65,535	Setting range $1/100 \leq G1/G2 \leq 100$
Cn-25	Electronic gear ratio G2 (denominator) (see note 2)	1	---	1 to 65,535	
Cn-26	Position command acceleration/deceleration time constant	0	× 0.1 ms	0 to 640	Sets the time constant for smoothing.
Cn-27	Feed-forward command filter	0	× 0.1 ms	0 to 640	Sets the feed-forward command filter.
Cn-28	Compensating gain (HA/LA/V/W Models)	0	---	0 to 100	Adjustment gain during position control
Cn-29	Unit number setting (HA/LA/V/W Models)	0	---	0 to 14	Unit number setting used during multi-axis communications

Note 1. Cn-04 (speed loop gain) is factory set for three times the load inertia. Therefore, if the load inertia is extremely small, some oscillation may occur. If it does, then lower Cn-04 to 20 or less.

Note 2. After the settings for Cn-11 (number of encoder pulses), Cn-24 (Electronic gear ratio G1 (numerator)), and Cn-25 (Electronic gear ratio G2 (denominator)) have been made, they become effective when the power is turned on again after having been cut off. (Check to see that the LED display has gone off.)

Note 3. Do not change the setting of Cn-11 (number of encoder pulses). The motor might not operate correctly if the setting is changed.

Note 4. Refer to the *Computer Monitor Software Instruction Manual (I513)* for OMNUC U-series Servo Drivers for more details on Cn-29 (unit number setting).

3-5-3 Internal Speed Control Settings

Function

- This function controls Servomotor speed using the speeds set in the parameters (No. 1, No. 2, and No. 3 internal speed settings).
- The internal speed is selected with control input terminals CN1-11 and CN1-12 (speed selection commands 1 and 2). The direction of rotation is specified with CN1-15 (the rotation direction command).
- When both speed selection commands 1 and 2 are OFF, the motor will decelerate to a stop in the software start deceleration time (specified in Cn-23) and then go into servo lock status. Depending on the parameter settings, it might be possible to perform position control in this status using pulse-train inputs. (HA/LA/V/W Models)

Setup Parameter Settings

- Set bit 2 of setup parameter number 2 (Cn-02) to “1.” When this bit is set to “1,” the internal speed control settings function can be used and CN1-11, 12, and 15 have the following functions:

Control inputs CN1-11 and 12: Speed selection commands 1 and 2 (SPD1 and SPD2)
 Control input CN1-15: Rotation direction command (RDIR)

- The following table shows the combinations of speeds and directions that can be selected with these three control inputs.

CN1-11 SPD1	CN1-12 SPD2	CN1-15 RDIR	Internal speed setting, Rotational direction
OFF	ON	OFF	No. 1 internal speed setting, forward
		ON	No. 1 internal speed setting, reverse
ON	ON	OFF	No. 2 internal speed setting, forward
		ON	No. 2 internal speed setting, reverse
ON	OFF	OFF	No. 3 internal speed setting, forward
		ON	No. 3 internal speed setting, reverse

Internal Speed Control Settings and Position Control (HA/LA/V/W Models)

- When bit F of setup parameter number 1 (Cn-01) is set to “1,” the control mode will be “internal speed control settings and position control.”
- In this control mode, it is possible to perform speed control using the internal speed control settings as well as position control using the pulse-train inputs.
- When both SPD1 and SPD2 are OFF, the motor will be decelerated, the positioning completion output will be output, and the servo will enter servo lock status. It will still be possible to receive pulse command inputs in servo lock status.

Note Input pulse commands after the positioning completion output (INP) is turned ON. The Unit will ignore any pulses input before the positioning completion output goes ON.

□ User Parameter Settings

PRM No.	Parameter name	Factory setting	Unit	Setting range	Explanation
Cn-07	Software start acceleration time	0	ms	0 to 10,000	Sets the time for the motor to accelerate from 0 r/min to 4,500 r/min.
Cn-23	Software start deceleration time	0	ms	0 to 10,000	Sets the time for the motor to decelerate from 4,500 r/min to 0 r/min.
Cn-26	Position command acceleration/deceleration time constant	0	0.1 ms	0 to 640	Sets the time constant for pulse smoothing.
Cn-1F	No. 1 internal speed setting	100	r/min	0 to 4,500	Sets the speed for when SPD1 is OFF and SPD2 is ON.
Cn-20	No. 2 internal speed setting	200	r/min	0 to 4,500	Sets the speed for when SPD1 is ON and SPD2 is ON.
Cn-21	No. 3 internal speed setting	300	r/min	0 to 4,500	Sets the speed for when SPD1 is ON and SPD2 is OFF.

Note 1. The software start acceleration and deceleration times are effective on the internal speed settings.

Note 2. The actual acceleration and deceleration times are found by means of the following formula:

$$\text{Actual acceleration (deceleration) time} = \frac{\text{Internal speed setting (r/min)}}{4,500 \text{ (r/min)}} \times \text{Software start acceleration (deceleration) time}$$

Note 3. The position command acceleration/deceleration time constant is effective on the pulse command.

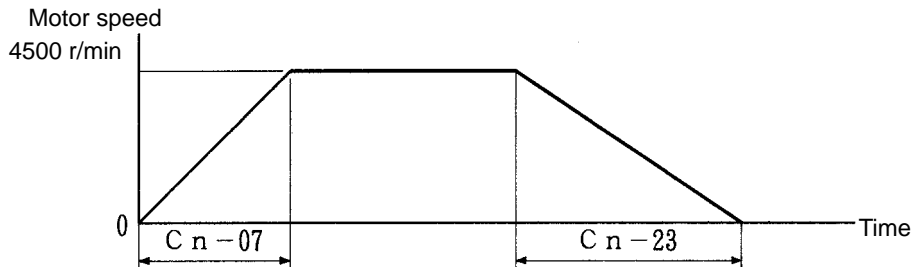

Operation Example

Internal Speed Control Settings + Position Control (HA/LA/V/W Models)

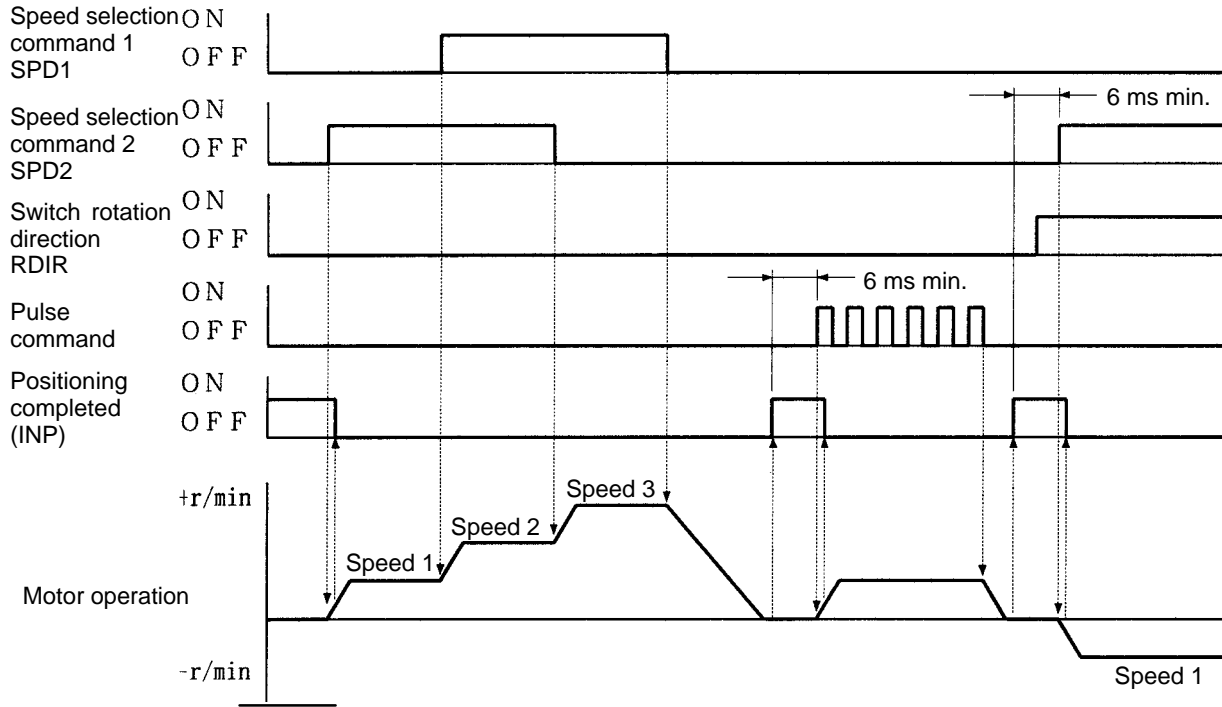

3-5-4 Electronic Gear Function: Position Control

Function

- The motor will be driven with a pulse determined by multiplying the command pulse count by the electronic gear ratio.
- The electronic gear is useful for the following applications:
 - To fine-tune the position and speed of two lines that must be synchronized.
 - When using a positioner with a low command pulse frequency.
 - To set the machine movement per pulse to a specific value, such as 0.01 mm.

Setting User Parameters

- The electronic gear is set as G1 divided by G2 (G1/G2). G1 is set in user parameter Cn-24; G2 is set in Cn-25. The target pulse count is computed as follows:

$$\text{Target pulse count} = \text{Command pulse count} \times \text{G1/G2}$$
- If $G1/G2 = 1$, the motor will turn once for every 8,192 command pulses (driver running at a factor of 4X).
- One pulse for the position deviation (deviation counter) display and positioning completion range will be equivalent to one input pulse (here the unit is said to be the command).

PRM No.	Parameter name	Factory setting	Unit	Setting range	Explanation
Cn-24	Electronic gear ratio G1 (numerator)	4	---	1 to 65,535	Setting range $1/100 \leq G1/G2 \leq 100$
Cn-25	Electronic gear ratio G2 (denominator)	1	---	1 to 65,535	

Note The factory settings will produce turn the motor once for every 2,048 input pulses.

Example

If G1 is set to 8,192 and G2 is set to 1,000, the motor will turn once for every 1,000 input pulses (output as 8,192 pulses). The motor speed will also be 8,192/1,000 times faster.

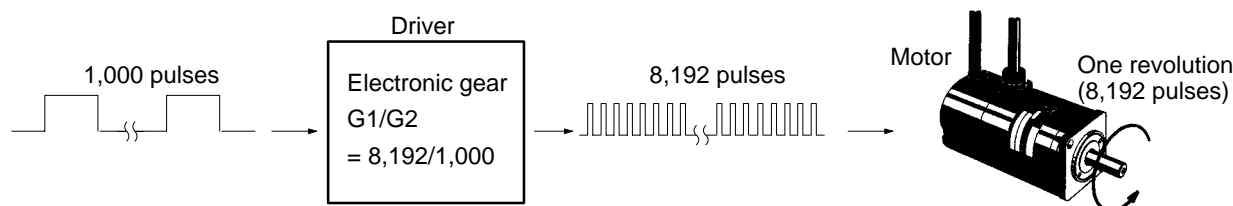

3-5-5 Encoder Dividing Function

Function

- With this function, any number of pulses can be set for encoder signals output from the Servo Driver.
- The number of pulses per Servomotor revolution can be set within a range of 16 to 2,048.
- Use this function for the following applications:
 When connecting to a positioner with a low response frequency.
 When it is desirable to set a pulse rate that is easily understandable.
 (For example, in a mechanical system in which a single Servomotor revolution corresponds to a movement of 10 mm, if the resolution is 5 μm/pulse, set the encoder dividing rate to 2,000 (pulses/revolution)).
- Set the parameters as shown in the following table.

PRM No.	Parameter name	Factory setting	Setting range	Explanation
Cn-0A	Encoder divider rate	1,000 pulses/revolution	16 to 2,048 pulses/revolution	Setting for number of output pulses from Servo Driver.

Note The power must be toggled to enable this parameter (be sure that the indicators go out completely).

□ Operation

- Incremental pulses are output from the Servo Driver through a frequency divider.

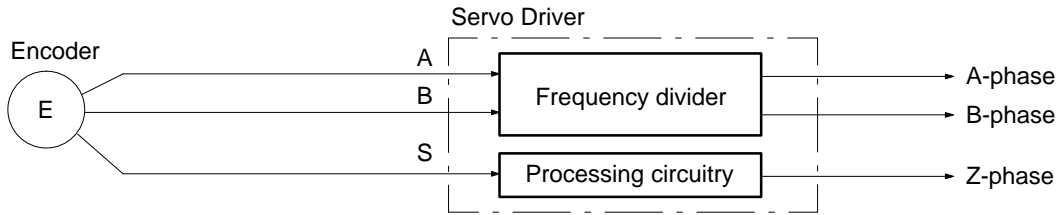

- The output phases of the encoder signal output from the Servo Driver are as shown below (when divider rate $Cn-0A = 2,048$).

Note The width of the Z-phase output pulse is not affected by the divider rate and will remain constant.

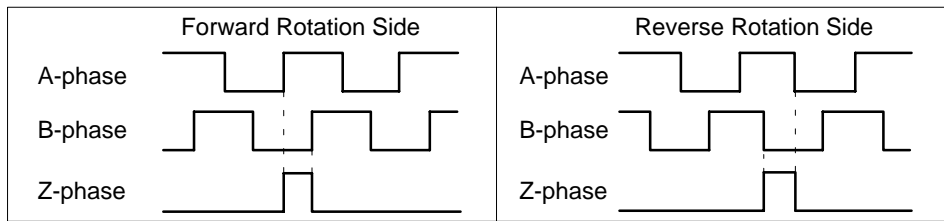

Note When the encoder divider rate is set to other than 2,048, 1024, 512,...., the phase difference for phases A and B is not 90° , but scatters for time T. (See the diagram below.)

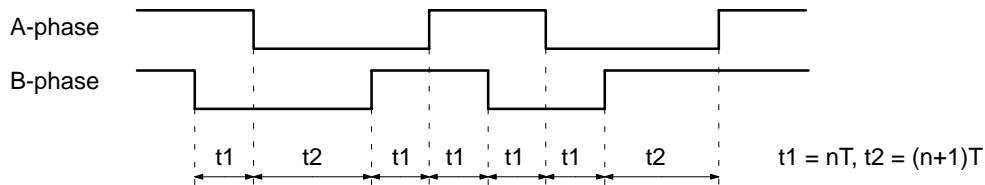

In this diagram, T represents the time between phase A and phase B, and n is an integer that satisfies the following formula (with digits below the decimal point discarded).

$$n = 2,048/\text{encoder divider rate}$$

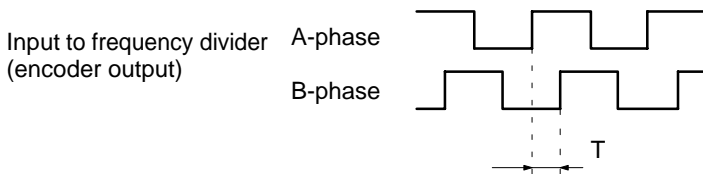

3-5-6 Bias Function: Position Control

The bias function shortens positioning time by adding the bias rotational speed to the speed command when the residual pulses in the deviation counter exceed the positioning completion range.

Function

- When the residual pulses in the deviation counter exceed the positioning completion range (Cn-1b), this function adds the bias rotational speed (Cn-1C) to the speed command. When the pulses are within the positioning completion range, it stops adding the bias rotational speed.

Parameters to be Set

PRM No.	Parameter name	Factory setting	Unit	Setting range	Explanation
Cn-1b	Positioning completion range	3	Command units	1 to 250	Sets the range for positioning completion signal output.
Cn-1C	Bias rotational speed	0	r/min	0 to 450	Sets position control bias.

Note 1. When not using the bias function, set the bias rotational speed to "0."

Note 2. As the bias rotational speed increases, Servomotor rotation becomes more unstable. The optimal value changes depending on the load, gain, and positioning completion range, so observe the response while making the adjustment. Start with the bias rotational speed set to 0 and slowly increase it.

Operation

- When the residual pulses in the deviation counter exceed the positioning completion range (Cn-1b), the bias rotational speed (Cn-1C) is added to the deviation counter output (speed command).
- When the pulses are within the positioning completion range, the bias rotational speed is no longer added to the speed command.
- For internal processing block configuration, refer to the position loop block diagram in 3-7-2 *Manually Adjusting Gain*.

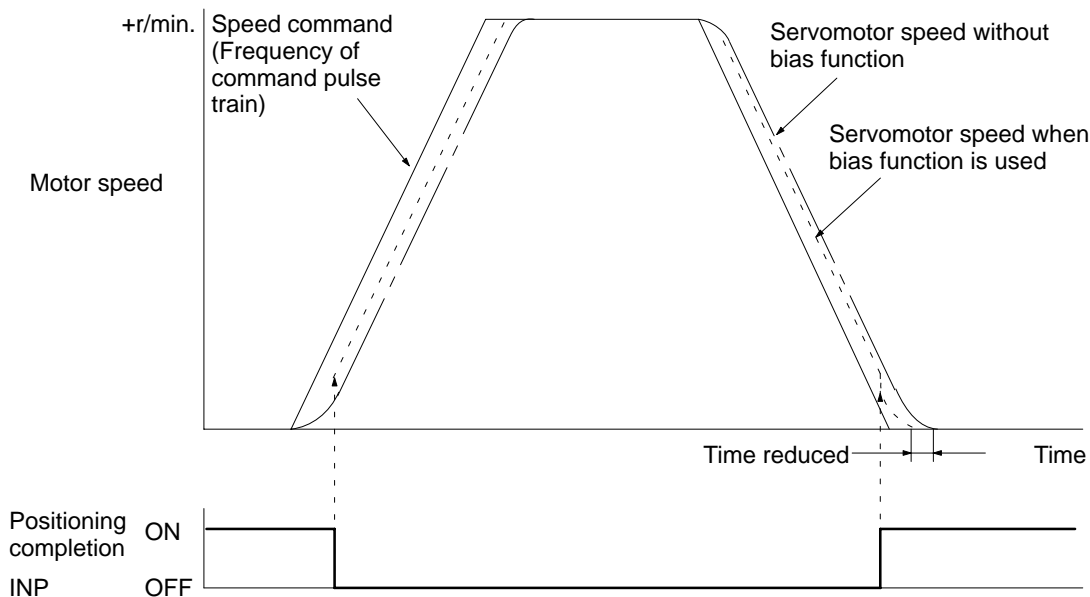

3-5-7 Torque Limit Function

□ Function

- This function limits the Servomotor’s output torque.
- This function can be used to protect the Servomotor and machine system by preventing excessive force or torque on the machine system when the machine (moving part) pushes against the work-piece with a steady force, such as in a bending machine.
- There are two methods for limiting the torque:
 1. Limit the steady force applied during normal operation with user parameters Cn-08 (forward torque limit) and Cn-09 (reverse torque limit).
 2. Limit operation with external signals connected to pins CN1-11 (PCL: forward current limit input) and CN1-12 (NCL: reverse current limit input). Set user parameters Cn-18 (forward rotation external current limit) and Cn-19 (reverse rotation external current limit).

□ Parameter Settings

Method 1: Limiting the Force Applied During Operation

- User Parameter Settings

PRM No.	Parameter name	Factory setting	Unit	Setting range	Explanation
Cn-08	Forward torque limit	Maximum torque	%	0 to maximum torque	This parameter sets the output torque limit for the forward direction (as a percentage of the rated torque).
Cn-09	Reverse torque limit	Maximum torque	%	0 to maximum torque	This parameter sets the output torque limit for the reverse direction (as a percentage of the rated torque).

Note Set these parameters to the maximum torque (the factory setting) when the torque limit function isn’t being used.

Method 2: Limiting Operation with External Signals

- Setup Parameter Settings (Bit 2 of Cn-02 = 0)

Set bit 2 of Cn-02 (the input command mode) to “0.” When bit 2 is “0,” control input terminal CN1-11 will be PCL (forward current limit input), CN1-12 will be NCL (reverse current limit input), and it will be possible to use the external current limit function.

- User Parameter Settings

PRM No.	Parameter name	Factory setting	Unit	Setting range	Explanation
Cn-18	Forward rotation external current limit	100	%	0 to maximum torque	This parameter sets the output torque limit (as a percentage of the rated torque) when the forward rotation current limit is input.
Cn-19	Reverse rotation external current limit	100	%	0 to maximum torque	This parameter sets the output torque limit (as a percentage of the rated torque) when the reverse rotation current limit is input.

3-5-8 Brake Interlock (For Motors with Brakes)

Magnetic Brakes

The magnetic brakes for Servomotors with brakes are specialized holding brakes with non-magnetized operation. Therefore set the parameters so that the brake power supply is turned off after the Servomotor stops. If the brake is applied while the Servomotor is operating, the brake will suffer abnormal wear or even damage, and will quickly become defective.

For wiring methods, refer to *2-2-5 Peripheral Device Connection Examples*.

Function

The output timing of the brake interlock signal (BKIR) that control turning the magnetic brake ON and OFF can be set.

Parameters to be Set

PRM No.	Parameter name	Factory setting	Unit	Setting range	Explanation
Cn-12	Brake timing 1	0	10 ms	0 to 50	Delay time setting from brake command until servo turns off.
Cn-15	Brake command speed	100	r/min	0 to 4,500	Sets rotational speed for outputting brake commands.
Cn-16	Brake timing 2	50	10 ms	10 to 100	Waiting time from servo-off to brake command output.

□ Operation

Timing for Run Command (RUN) (When Servomotor is Stopped)

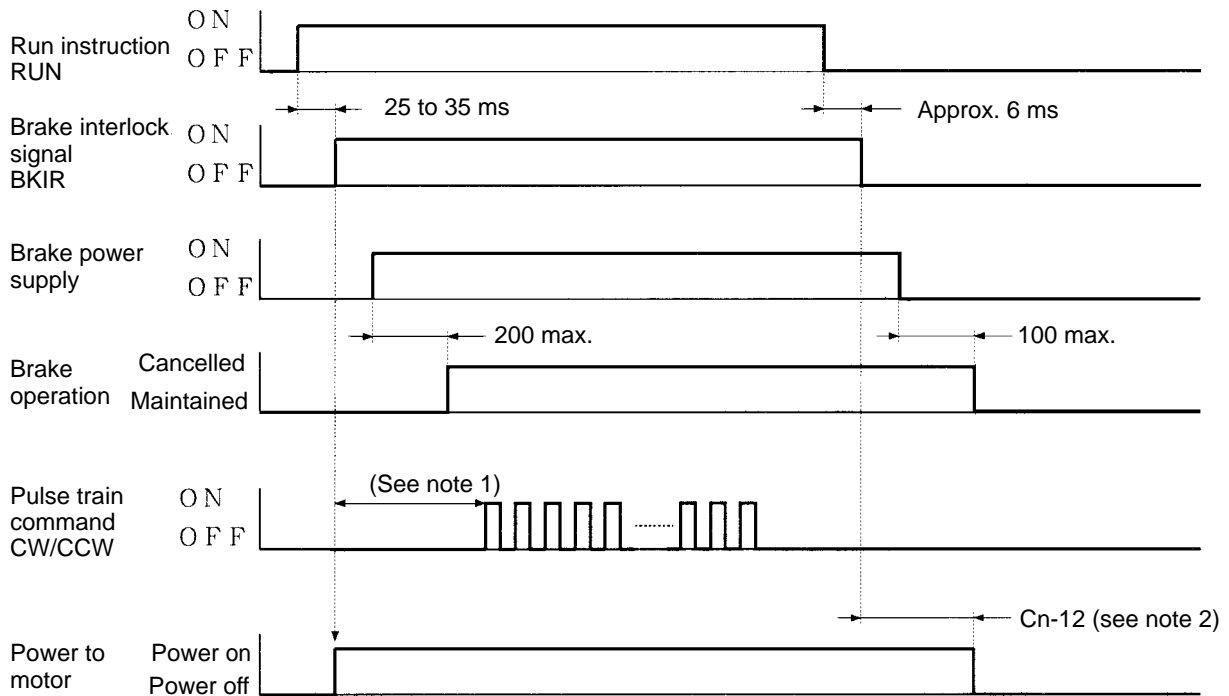

Note 1. It takes up to 200 ms for the brake to be cleared after the brake power supply has been turned on. Taking this delay into account, have the speed command be given after the brake has been cleared.

Note 2. It takes up to 100 ms for the brake to be held after the brake power supply has been turned off. When using it for the vertical shaft, take this delay into account and set brake timing 1 (Cn-12) so that the Servomotor will not receive power until after the brake is held.

Timing for Power Supply (When Servomotor is Stopped)

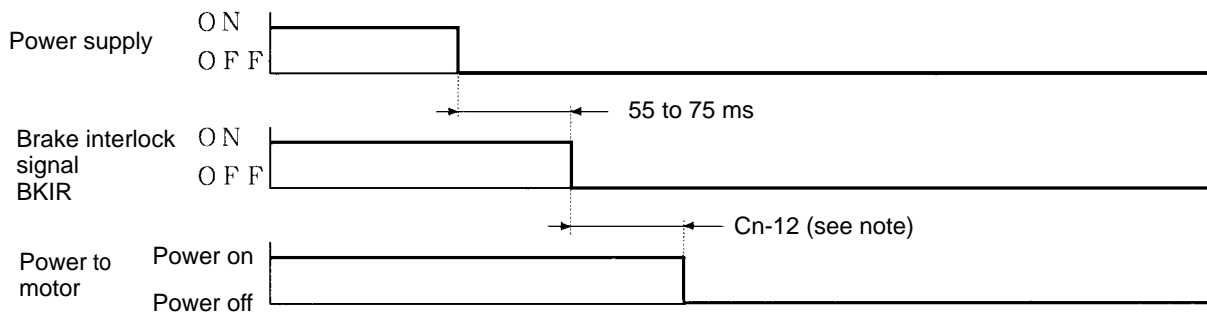

Note It takes up to 100 ms for the brake to be held after the brake power supply has been turned off. When using it for the vertical shaft, take this delay into account and set brake timing 1 (Cn-12) so that the Servomotor will not receive power until after the brake is held.

Timing for Run Command (RUN), Errors, Power Supply: Servomotor Stopped

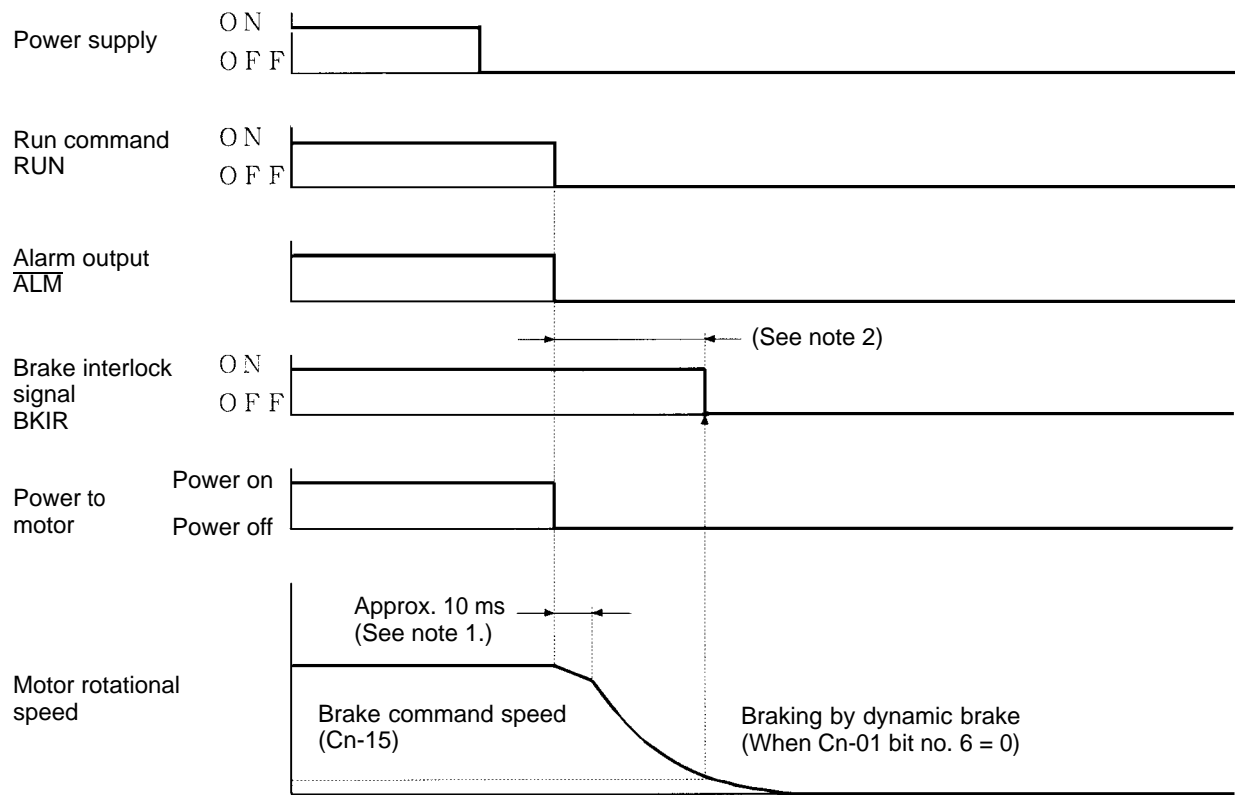

Note 1. For the approximately 10 ms it takes from when the power to the Servomotor turns off until the dynamic brake operates, the Servomotor rotates by momentum.

Note 2. If the Servomotor rotational speed falls below the speed set for the brake command speed (Cn-15), or if the time set for brake timing 2 (Cn-16) elapses after the Servomotor stops receiving power, the brake interlock signal (BKIR) will turn OFF.

3-6 Trial Operation

After the wiring is complete and the parameter settings have been made, conduct a trial operation. First, check with rotation of the motor without connecting a load (i.e., without connecting the mechanical system). Then, connect the mechanical system, auto-tune the system, and confirm that the correct operation pattern is performed.

3-6-1 Preparations for Trial Operation

Preparations

Power Off

The power supply must be toggled to apply some of the parameter settings. Always turn off the power supply before starting.

No Motor Load

Do not connect a load to the motor shaft during trial operation, just in case the motor runs out of control.

Stopping the Motor

Make sure that the power switch can be turned off or the Run command used to stop the motor immediately in case of trouble.

Connecting a Parameter Unit

Connect a Parameter Unit to the CN3 connector on the front of the Servo Driver if one is not already connected.

Actual Trial Operation

(1) Powering Up

- With the run command (RUN) OFF, apply an AC voltage.
- After internal initialization, the mode will be the status display mode.

Display example:



- Set the speed loop gain (Cn-04) to 20 or less. (Match the gain with no load.)
1. Confirm the initial display shown above.
 2. Press the MODE/SET Key to enter the settings mode.
 3. Press the Up Key to specify user parameter Cn-04.
 4. Press the DATA Key to display the setting of Cn-04.
 5. Press the Down Key to change the setting to 20.
 6. Press the DATA Key to record the new setting in memory.

7. Press the DATA Key again to return to the parameter number display.

(2) Jog Operations (See 3-6-2 Jog Operations.)

- Perform jog operations using the Parameter Unit and confirm the following:
Does the motor turn in the correct direction?
Is there any unusual sound or vibration?
Do any error occur?
- If an error occurs, refer to *Chapter 4 Application* for troubleshooting.

(3) Connect a load and auto-tune (See 3-7 Making Adjustments.)

- Connect the motor shaft to the load (mechanical system) securely, being sure to tighten screws so that they will not become loose.
- Perform auto-tuning with the Parameter Unit.

(4) Turning ON the Run command Input

- Turn ON the run command input. The Servomotor will go into servo-ON status.
- Give a speed command, or carry out the following check with a jogging operation.

(5) Low Speed Operation

- Operate at low speed.
Apply a low-frequency pulse command.
The meaning of “low speed” can vary with the mechanical system. Here, “low speed” means approximately 10% to 20% of the actual operating speed.
- Check the following items.
 - Is the emergency stop operating correctly?
 - Are the limit switches operating correctly?
 - Is the operating direction of the machinery correct?
 - Are the operating sequences correct?
 - Are there any abnormal sounds or vibration?
 - Is anything abnormal occurring?
- If anything abnormal occurs, refer to *Chapter 4 Application* and apply the appropriate countermeasures.

(6) Operation Under Actual Load Conditions

- Operate the Servomotor in a regular pattern and check the following items.
 - Is the speed correct? (Use the speed display.)
 - Is the load torque roughly equivalent to the measured value? (Use the torque command display.)
 - Are the positioning points correct?
 - When an operation is repeated, is there any discrepancy in positioning?
 - Are there any abnormal sounds or vibration?
 - Is either the Servomotor or the Servo Driver abnormally overheating?
 - Is anything abnormal occurring?
- If anything abnormal occurs, refer to *Chapter 4 Application* and apply the appropriate countermeasures.

(7) Readjust the gain.

- If the gain could not be adjusted completely using auto-tuning, perform the procedure in *3-7 Making Adjustments* to adjust the gain.

3-6-2 Jog Operations

Jog operations rotate the Servomotor in a forward or reverse direction using the Parameter Unit. Jog operations are made possible when system check mode Cn-00 is set to “00.” The items in parentheses in the following explanation indicate operations using the Handy-type Parameter Unit.

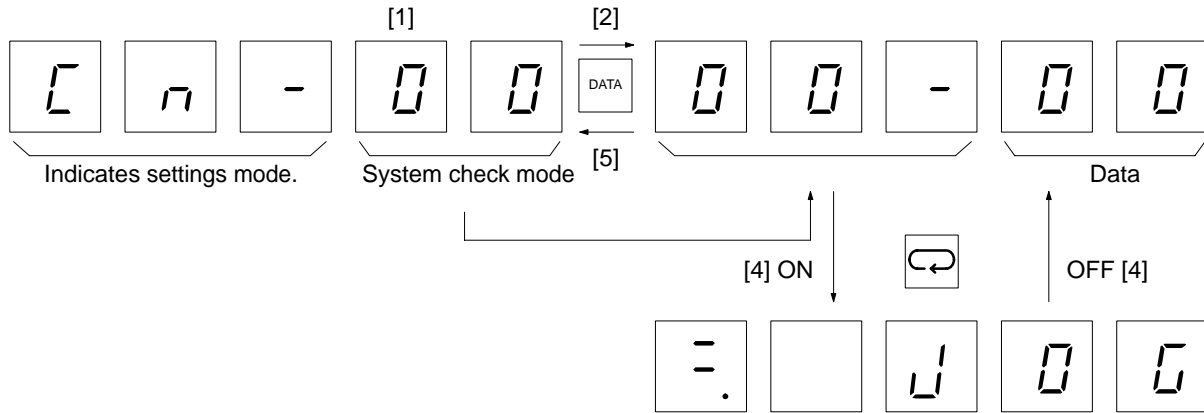

Operating Procedure (Key in Parentheses are for Mounted-type Parameter Units)

1. Confirm that the initial display is shown (–. bb).
2. Press the MODE/SET Key to enter the settings mode.
3. Using the Up and Down Keys, set parameter number “00.” (System check mode)
4. Press the DATA Key to display the setting of Cn-00.
5. Using the Up and Down Keys, set the parameter to “00.” (Jog operation)
6. Press the MODE/SET Key to shift to the jog display.
7. Press the SERVO (DATA) Key to turn on the servo.
8. Press the Up Key to jog forward. Forward operation will continue as long as the key is held down.
9. Press the Down Key to jog in reverse. Reverse operation will continue as long as the key is held down.
10. Press the SERVO (DATA) Key to turn off the servo.
11. Press the MODE/SET Key to return to the data display.
12. Press the DATA Key to return to the settings mode.

User Parameter Settings

The rotational speed during jog operation can be set with user parameter Cn-10, as shown in the following table.

PRM No.	Parameter name	Factory setting	Unit	Setting range	Explanation
Cn-10	Jog speed	500	r/min	0 to 4,500	Speed setting for jog operation

3-7 Making Adjustments

3-7-1 Auto-tuning

Auto-tuning rotates the Servomotor with a load connected (mechanical system), and automatically adjusts the position loop gain, the speed loop gain, and the speed loop integration time constant. When adjustments cannot be made by auto-tuning, refer to 3-7-2 *Manually Adjusting Gain*.

□ Executing Auto-tuning

Make sure that Cn-28 for compensation gain adjustment is set to 0 before performing auto-tuning. Proper gain adjustment may not be possible with auto-tuning if the parameter is not set to 0. This parameter is factory-set to 0.

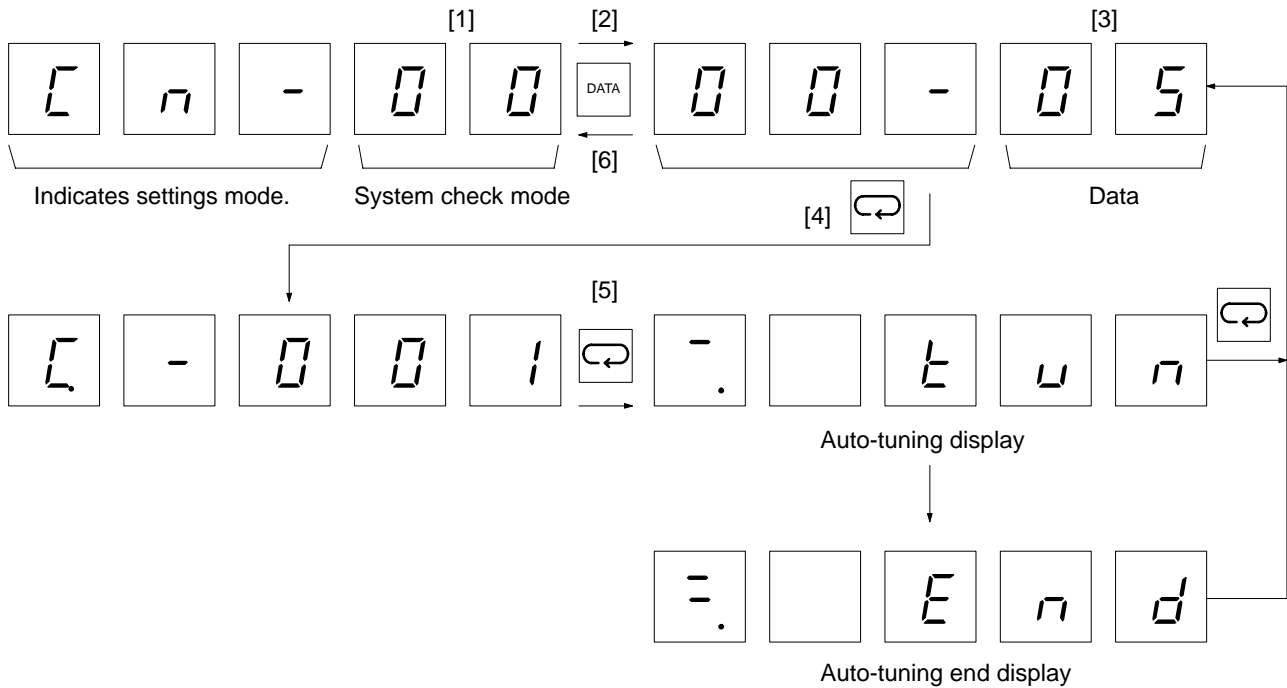

1. Confirm that the initial display is shown (-. bb).
2. Press the MODE/SET Key to enter the settings mode.
3. Using the Up and Down Keys, set parameter number “00.” (System check mode)
4. Press the DATA Key to display the setting of Cn-00.
5. Using the Up and Down Keys, set the parameter to “05.” (Auto-tuning)
6. Press the MODE/SET Key to switch to the mechanical rigidity selection display.
7. Using the Up and Down Keys, adjust the rigidity to the mechanical system.(Refer to *Selecting Mechanical Rigidity* below.)
8. Press the MODE/SET Key to switch to the auto-tuning display.

9. Press the SERVO (DATA) Key to turn on the servo. (This step is not required if the Run Command Input is ON.)
10. Perform auto-tuning, using the Up Key for forward operation and the Down Key for reverse operation. Continue pressing the key until "End" is displayed, indicating that auto-tuning has been completed.
11. Release the key. The data display will return.
12. Press the DATA Key to return to the settings mode.

Selecting Mechanical Rigidity

Select the set value to match the rigidity of the mechanical system.

HA/LA/V/W Models

Response	Set value	Position loop gain (1/s)	Representative applications
Low	001	16	Articulated robots, harmonic drives, chain drives, belt drives, rack and pinion drives, etc.
	002	28	
Medium	003	40	XY tables, Cartesian-coordinate robots, general-purpose machinery, etc.
High	004	56	Ball screws (direct coupling), feeders, etc.
	005	78	
	006	108	
	007	130	

H/L Models

Response	Set value	Position loop gain (1/s)	Representative applications
Low	001	20	Articulated robots, harmonic drives, chain drives, belt drives, rack and pinion drives, etc.
Medium	002	40	XY tables, Cartesian-coordinate robots, general-purpose machinery, etc.
High	003	60	Ball screws (direct coupling), feeders, etc.

Note The higher the rigidity of the mechanical system is, the higher the response becomes.

Auto-tuning

- Auto-tuning will not be complete until at least three operations have been completed. Be sure there is plenty of room for the machine to operate.
- If the auto-tuning is not complete after three operation, operations will be repeat as long as the key is held down.
- The Servomotor rotation speed will be approximately 1/2 that of the jog speed (Cn-10).
- Auto-tuning will automatically change the setting of the user parameter position loop gain (Cn-1A), speed loop gain (Cn-04), and speed loop integration time constant (Cn-05). These values will not be changed, however, until the auto-tuning operation has been completed.

- If auto-tuning does not complete or if the gain set via auto-tuning is not sufficient, adjust the gain manually using the procedure in *3-7-2 Manually Adjusting Gain*.

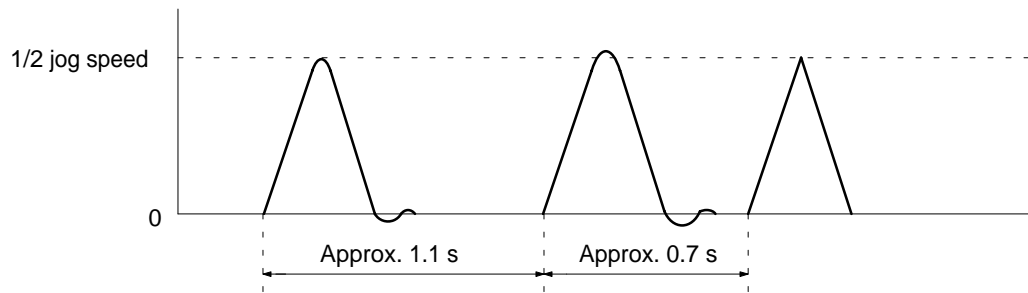

3-7-2 Manually Adjusting Gain

Make sure that Cn-28 for compensation gain adjustment is set to 0 before performing auto-tuning. This parameter is factory-set to 0.

! Caution Never make extreme changes in the setting. Doing so may cause unstable operation or result in injury. Gradually vary the gain setting from the standard value shown below and check motor operation while changing the settings.

□ Gain Adjustment Flowchart

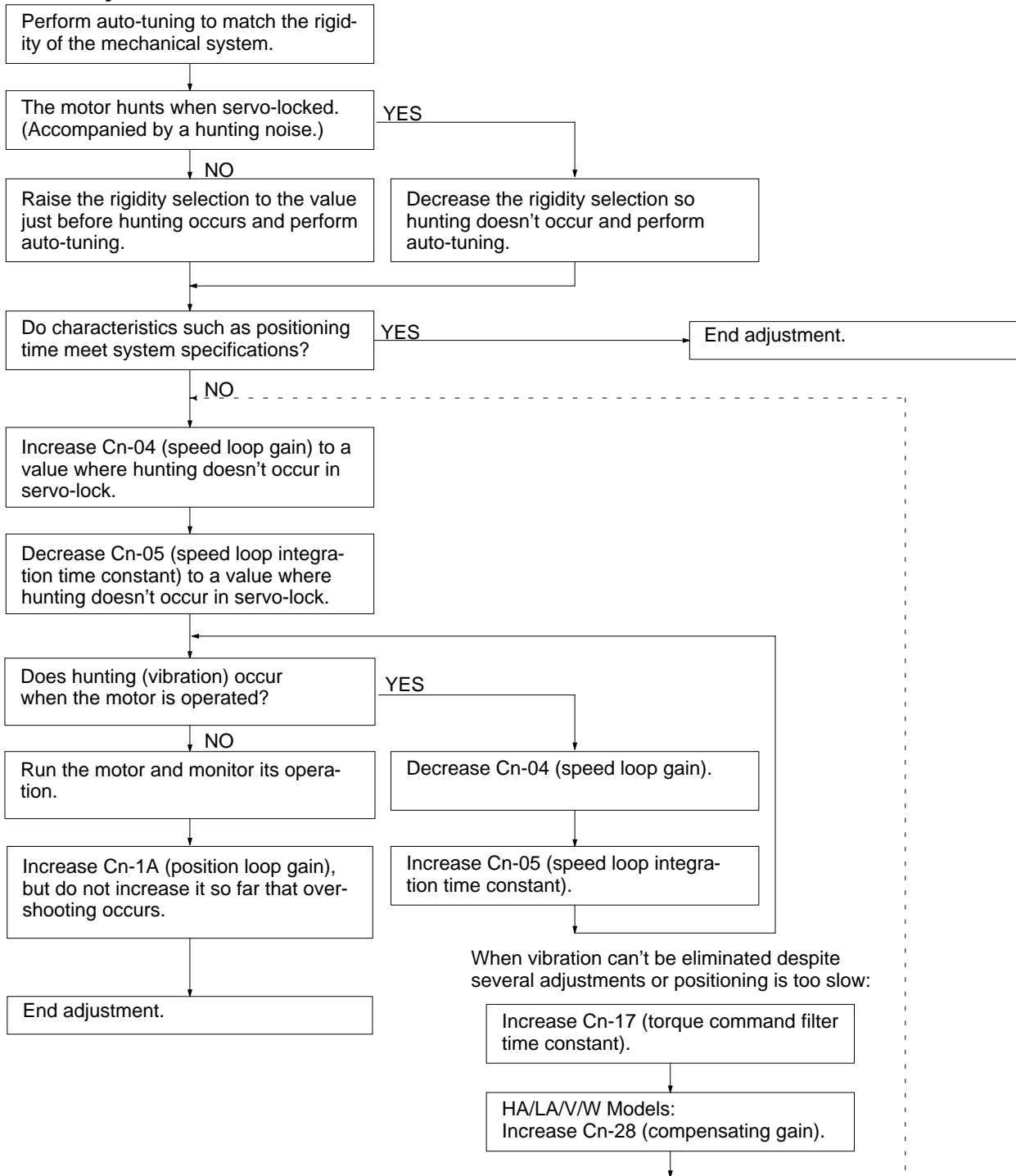

Gain Adjustment Standards

The following table shows reference values for gain adjustment. Adjustments can be made quickly if these values are used as standards. Make the initial gain setting based on the load inertia.

Load inertia factor	Speed loop gain Cn-04 (Hz)	Speed loop integration constant Cn-05 (ms)	Position loop gain Cn-1A (1/s)	Comments
1	80	40	60	High rigidity
3	80	20	40	Factory setting
3	120	30	40	---
10	350	40	40	---
20	420	80	20	Moderate rigidity
20	200	120	10	Low rigidity

Adjustment Parameters

Adjusting Speed Loop Gain

PRM No.	Parameter name	Factory setting	Unit	Setting range	Explanation
Cn-04	Speed loop gain	80	Hz	1 to 2,000	Adjusts the speed loop response. As the gain is increased, the servo rigidity is strengthened. The greater the inertia rate, the higher this is set. If the gain is set too high, oscillation will occur.

When the speed loop gain is manipulated, the response is as shown in the diagram below.

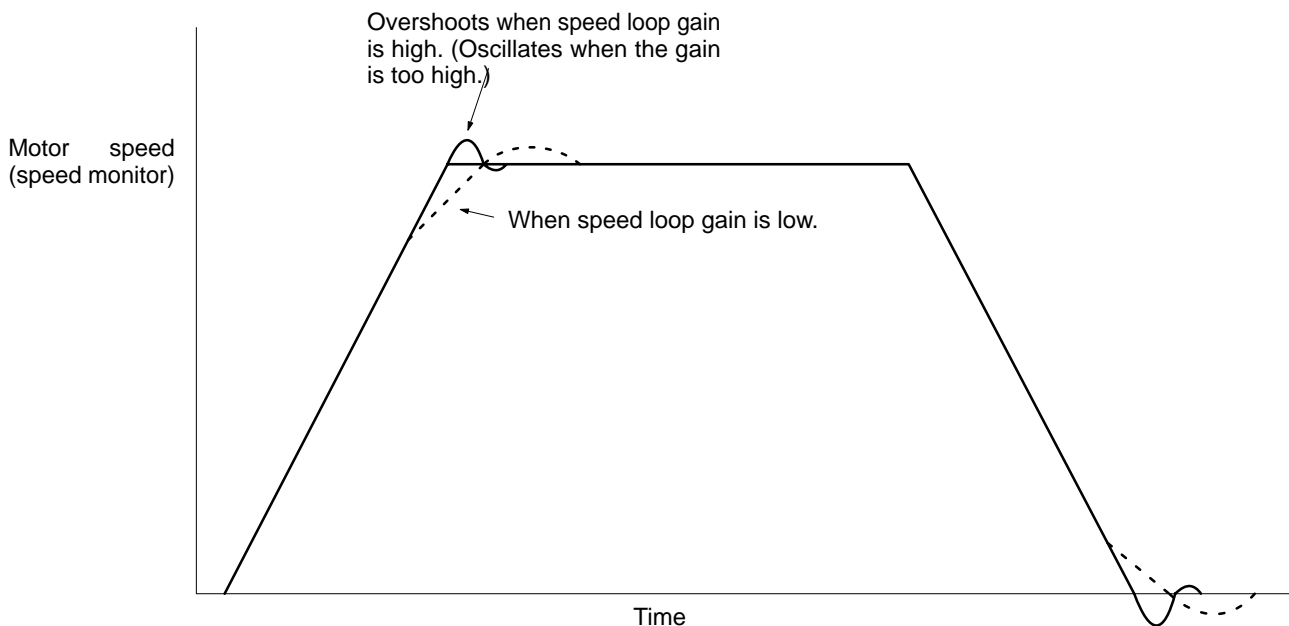

□ Adjusting the Speed Loop Integration Time Constant

PRM No.	Parameter name	Factory setting	Unit	Setting range	Explanation
Cn-05	Speed loop integration constant	20	1 ms/ 0.01 ms	2 to 10,000	Speed loop integration constant. As the constant is increased, the response is shortened and the resiliency toward external force is weakened. If it is set too short, oscillation will occur. The unit set in bit b of Cn-02 (integration constant's unit) is used to set the constant. (HA/LA/V/W Models)

When the speed loop integration time constant is manipulated, the response is as shown in the diagram below.

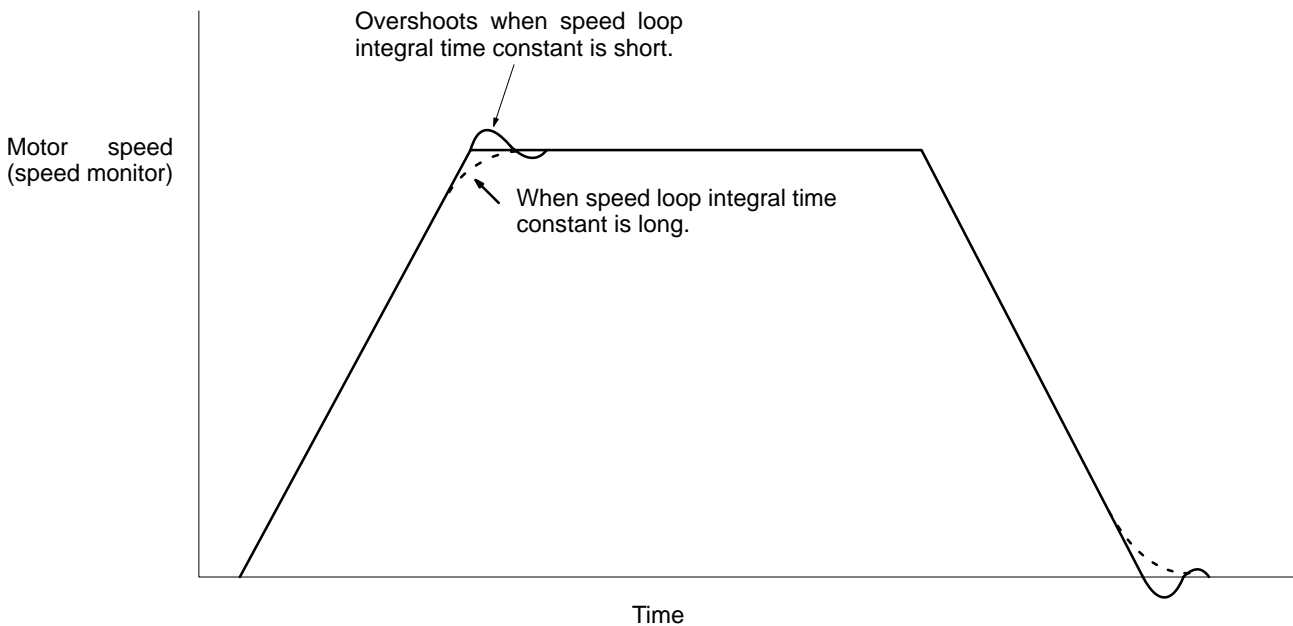

PRM No.	Parameter name	Factory setting	Unit	Setting range	Explanation
Cn-17	Torque command filter time constant	4	0.1 ms	0 to 250	Sets torque command filter time constant. Increase the time constant to reduce oscillation due to machinery resonance frequency. The filter characteristic is switched using the torque command filter time constants. (HA/LA/V/W Models)
Cn-1A	Position loop gain	40	1/s	1 to 500	For servo-lock strength adjustment when position lock function is used. Adjust to match mechanical rigidity.

□ Position Loop Gain

The responsiveness of the servo system is determined by the position loop gain. When a servo system has high position loop gain, the responsiveness is greater and positioning can be faster. In order for position loop gain to be raised, the mechanical rigidity and the characteristic frequency must be increased. For general NC machine tools, the range is 50 to 70 (1/s); for general machinery and assembly devices, it is 30 to 50 (1/s); for industrial robots, it is 10 to 30 (1/s). The factory setting for position loop gain is 40 (1/s), so it should be lowered for systems with low rigidity.

Position loop gain is generally expressed as follows:

$$\text{Position loop gain (Kp)} = \frac{\text{Instruction command frequency (pulses/s)}}{\text{Deviation counter's residual pulse amount (pulses)}} \quad (1/s)$$

In addition, the system response setting is 1/Kp, so in order to increase the responsiveness, it is necessary to increase the position loop gain. If a system has low rigidity or low characteristic frequency, increasing the position loop gain sympathetic vibration of machinery will occur and an alarm will be generated.

If position loop gain is low, positioning time can be improved by using feed-forward control.

In addition to this method, positioning completion can be speeded up by using the bypass function.

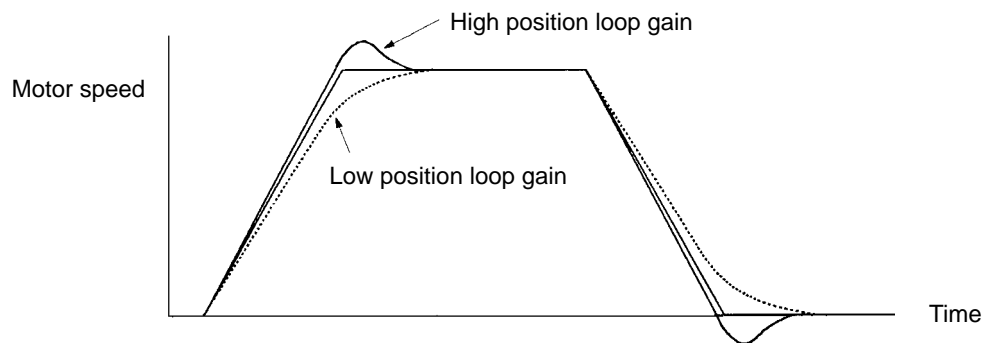

PRM No.	Parameter name	Factory setting	Unit	Setting range	Explanation
Cn-1b	Positioning completion range	3	Command units	0 to 250	Sets the range for the positioning completion signal output. (Generally set according to the precision required by the system.) Increasing the positioning completion range too much can cause the positioning completion output to turn ON during low-speed operation or other times when there are few residual pulses.
Cn-1C	Bias rotational speed	0	r/min	0 to 450	Used to reduce positioning time. Positioning time will be decrease as the bias rotational speed is increased, but will become unstable if it is increased too much. Increase the value gradually from 0 and observe the affect on the system.
Cn-1d	Feed-forward amount	0	%	0 to 100	Position control feed-forward compensation.

□ Feed-forward Amount

The feed-forward amount is effective when the position loop gain is set to less than 25 1/s. It will not be very effective when the position loop gain is higher than 25 1/s.

Increasing the feed-forward amount too much will cause excessive overshooting.

The feed-forward amount is not sent through the deviation counter, but is applied directly to the speed loop. The differential of the deviation counter is thus not applied, causing a faster response when the load response is delayed from the commands.

Be sure that the position loop is completely adjusted and that the speed loop is operating safely before adjusting the feed-forward amount.

Increasing the feed-forward amount too much will cause the speed command to oscillate, resulting in abnormal noise from the motor. Increase the feed-forward amount slowly from 0%, adjusting it so that the positioning completion output is not adversely affected (e.g., turn repeatedly ON and OFF) and so that the speed does not overshoot.

PRM No.	Parameter name	Factory setting	Unit	Setting range	Explanation
Cn-1E	Deviation counter overflow level	1,024	× 256 commands	1 to 32,767	Sets the level for detection of deviation counter overflow. The residual pulses in the deviation counter will equal the command pulse frequency divided by the position loop gain. Divide this value by 256, add a reasonable amount of leeway, and set the deviation counter overflow level to the resulting value.
Cn-26	Position command acceleration/deceleration time constant	0	× 0.1 ms	0 to 640	Sets the time constant for smoothing (position command soft start function). Even if the position command pulses are input in steps, the time constant set here will be used to accelerate/decelerate the motor. The same time will be used for both acceleration and deceleration. Set this parameter to 0 when using a position controller that has an acceleration/deceleration function.
Cn-27	Feed-forward command filter	0	× 0.1 ms	0 to 640	Sets the feed-forward command filter. This parameter acts as a low-pass filter to prevent the feed-forward amount from being applied too quickly when position command pulses are input in steps.
Cn-28	Compensating gain (HA/LA/V/W Models)	0	---	0 to 100	Decreases the speed loop gain by the set value when a large torque is output due to acceleration, deceleration, etc.

Compensating Gain

Increasing the compensating gain will reduce motor vibration and will also enable setting a larger speed loop gain, allowing faster positioning. Increasing the compensating gain too much will delay following accelerations/decelerations.

Adjust the compensating gain only after adjusting the speed loop gain (Cn-04) and the speed loop integration constant (Cn-05).

Depending on the values of the speed loop gain (Cn-04) and the speed loop integration constant (Cn-05), the upper limit of the compensating gain may be 100 or less. An error will occur if the compensating gain is set too high.

Set the compensating gain to 0 when auto-tuning. The gain will not be adjusted correctly if the compensating gain is not set to 0.

□ Position Loop Block Diagram

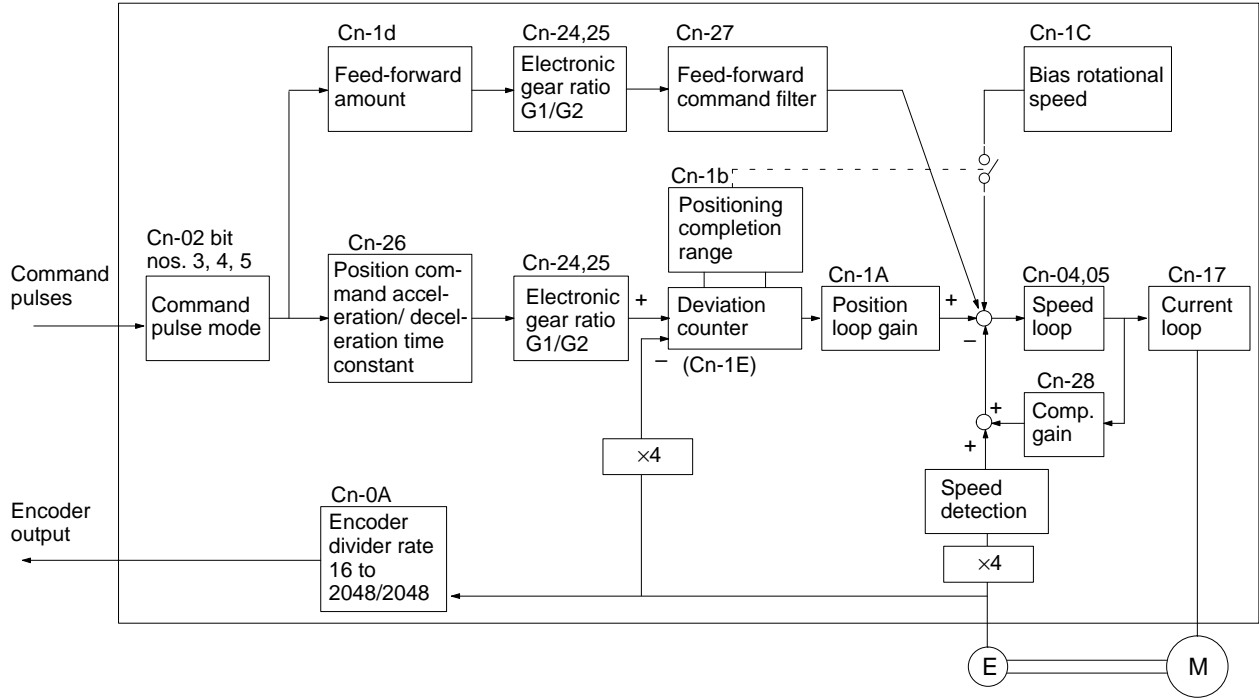

3-8 Regenerative Energy Absorption

Regenerative energy produced at times such as Servomotor deceleration is absorbed by the Servo Driver's internal capacitors, thereby preventing an increase in DC voltage. If the regenerative energy from the Servomotor becomes too large, however, an over-voltage error will occur. In such cases, it is necessary to connect a Regeneration Unit to increase the capacity for absorbing regenerative energy.

3-8-1 Calculating Regenerative Energy

Regenerative energy is produced when the direction of Servomotor rotation or output torque is reversed. The methods for calculating regenerative energy for the horizontal and vertical shafts are explained below.

Horizontal Axle

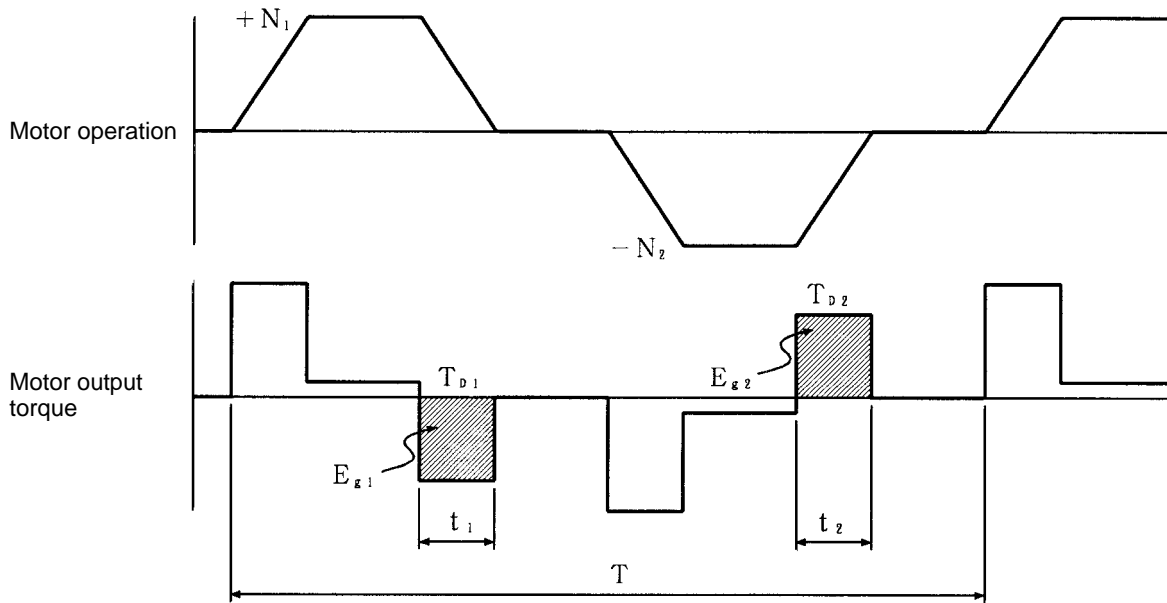

Note In the output torque graph, when the rotation direction and the torque direction match it is shown as positive.

The regenerative energy for each section can be found by means of the following formulas:

$$E_{g1} = 1/2 N_1 T_{D1} t_1 \cdot 0.105 \text{ [J]}$$

$$E_{g2} = 1/2 N_2 T_{D2} t_2 \cdot 0.105 \text{ [J]}$$

N_1, N_2 : Rotation speed at beginning of deceleration [r/min]

T_{D1}, T_{D2} : Deceleration torque [N · m]

t_1, t_2 : Deceleration time [s]

Note There is some loss due to winding resistance, so the actual regenerative energy will be approximately 90% of the figure derived by the formula.

The maximum regenerative energy for the Servo Driver's internal capacitors only can be found by means of the following formula:

$$E_g = (E_{g1}, E_{g2}) \text{ [J]}$$

E_g is the larger of E_{g1} and E_{g2} .

When regenerative energy is absorbed at the Servo Driver only, E_g must not exceed the amount of regenerative energy that can be absorbed at the Servo Driver. In addition, the average regenerative power when a Regeneration Unit is connected can be found by means of the following formula:

$$P_r = (E_{g1} + E_{g2})/T \text{ [W]}$$

T : Operation cycle [s]

E_g must not exceed the maximum regeneration absorption capacity of the Servo Driver when only the Servo Driver is used to absorb regenerative energy. When a Regeneration Unit is connected, the average regenerative power (P_r) must not exceed the regeneration processing power (12 W) of the Regeneration Unit.

Connect an external regeneration resistor when the regeneration processing power of the Regeneration Unit (12 W) is exceeded. Refer to 3-8-3 Absorption of Regenerative Energy with the External Regeneration Resistor for details on external regeneration resistors.

Vertical Axle

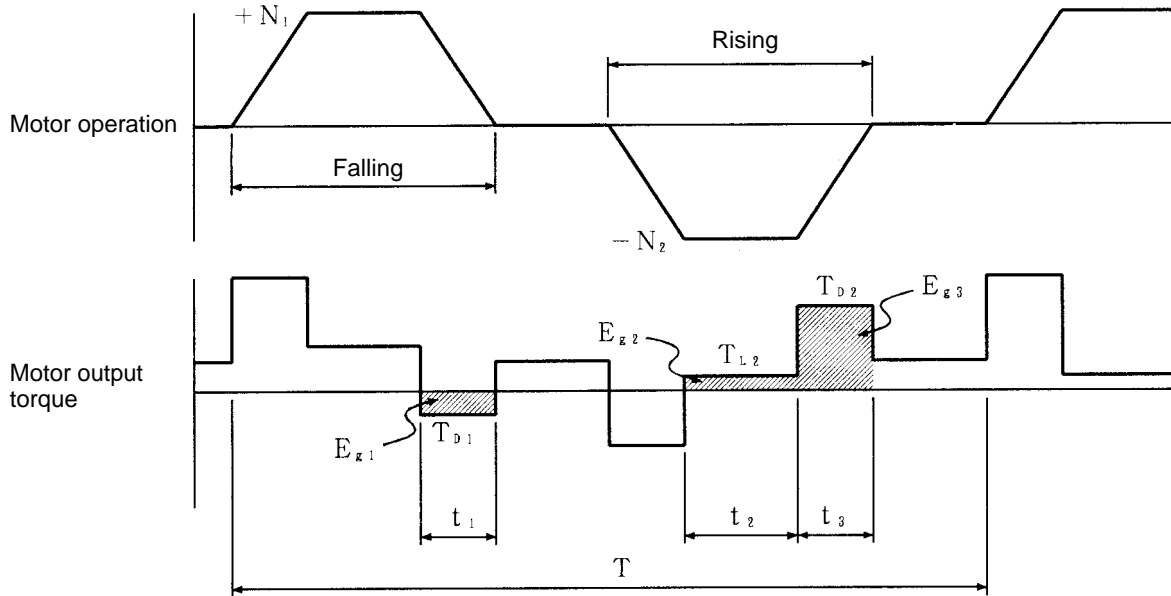

Note In the output torque graph, when the rotation direction and the torque direction match it is shown as positive.

The regenerative energy for each section can be found by means of the following formulas:

$$E_{g1} = 1/2 N_1 T_{D1} t_1 \cdot 0.105 \text{ [J]}$$

$$E_{g2} = N_2 T_{L2} t_2 \cdot 0.105 \text{ [J]}$$

$$E_{g3} = 1/2 N_2 T_{D2} t_3 \cdot 0.105 \text{ [J]}$$

N_1, N_2 : Rotation speed at beginning of deceleration [r/min]

T_{D1}, T_{D2} : Torque when declining [N · m]

T_{L2} : Deceleration torque [N · m]

t_1, t_3 : Travel time equivalent to torque when declining [s]

t_2 : Deceleration time [s]

Note There is some loss due to winding resistance, so the actual regenerative energy will be approximately 90% of the figure derived by the formula.

The maximum regenerative energy for the Servo Driver's internal capacitors only can be found by means of the following formula:

$$E_g \text{ is the larger of } E_{g1}, E_{g2} + E_{g3}.$$

When regenerative energy is absorbed at the Servo Driver only, E_g must not exceed the amount of regenerative energy that can be absorbed at the Servo Driver. In addition, the average regenerative power when a Regeneration Unit is connected can be found by means of the following formula:

$$P_r = (E_{g1} + E_{g2} + E_{g3}) / T \text{ [W]}$$

T: Operation cycle [s]

E_g must not exceed the maximum regeneration absorption capacity of the Servo Driver when only the Servo Driver is used to absorb regenerative energy. When a Regeneration Unit is connected, the average regenerative power (P_r) must not exceed the regeneration processing power (12 W) of the Regeneration Unit.

Connect an external regeneration resistor when the regeneration processing power of the Regeneration Unit (12 W) is exceeded. Refer to 3-8-3 *Absorption of Regenerative Energy with the External Regeneration Resistor* for details on external regeneration resistors.

3-8-2 Servo Driver Absorbable Regenerative Energy

Regenerative Energy Absorbed Internally

The Servo Driver absorbs regenerative energy by means of an internal capacitor. If there is more regenerative energy than can be absorbed by the capacitor, an overvoltage error will be generated and operation cannot continue. The amounts of regenerative energy that can be absorbed by the various Servo Drivers alone are shown in the tables below. If regenerative energy exceeding these values is produced, take the following measures.

- Connect a Regeneration Unit (R88A-RG08UA) (Refer to 3-8-3). (Models Conforming to UL/cUL Standards and Models Not Conforming to Any Standards)
- Lower the operating rotation speed. (The regenerative energy is proportional to the square of the rotation speed.)
- Lengthen the deceleration time. (Reduce the amount of regenerative energy per unit time.)
- When using multiple axes, the + terminals can be connected together and the – terminals can be connected together to use regenerative energy as the drive energy for the other axes (Refer to 3-8-4). (Models Conforming to EC Directives)

200-VAC Input Type

Model	Absorptive regeneration energy (J)	Maximum applicable load inertia (x10 ⁻⁴ kg m ²)	Remarks (see note *3)
R88D-UP02H(A)/UP02V (30 W)	7.0	0.63	Rotor inertia × 30, 4,500 r/min
R88D-UP03H(A)/UP03V (50 W)	8.7	0.78	Rotor inertia × 30, 4,500 r/min
R88D-UP04H(A)/UP04V (100 W)	13.3	1.2	Rotor inertia × 30, 4,500 r/min
R88D-UP08H(A)/UP08V (200 W)	23.9	3.69	Rotor inertia × 30, 3,000 r/min
R88D-UP12H(A)/UP12V (400 W)	21.1	3.8	Rotor inertia × 20, 3,000 r/min
R88D-UP20H(A)/UP20V (750 W)	52.2	13.4	Rotor inertia × 20, 3,000 r/min

Note 1. The input voltage is the value at 200 VAC. As the input voltage is increased, the amount of regenerative energy that can be absorbed is decreased.

Note 2. For Servomotors with brakes, add the brake inertia to the load inertia.

Note 3. This is the applicable range for the horizontal shaft. (No external force should be applied.)

100-VAC Input Type

Model	Absorptive regeneration energy (J)	Maximum applicable load inertia ($\times 10^{-4}$ kg m ²)	Remarks (see note *3)
R88D-UP03L(A)/UP03W (30 W)	7.0	0.63	Rotor inertia \times 30, 4,500 r/min
R88D-UP04L(A)/UP04W (50 W)	8.7	0.78	Rotor inertia \times 30, 4,500 r/min
R88D-UP10L(A)/UP10W (100 W)	13.3	1.2	Rotor inertia \times 30, 4,500 r/min
R88D-UP12L(A)/UP12W (200 W)	23.9	3.69	Rotor inertia \times 30, 3,000 r/min
R88D-UP15LA/UP15W (300 W)	99.5	3.8	Rotor inertia \times 20, 4,500 r/min

Note 1. The input voltage is the value at 100 VAC. As the input voltage is increased, the amount of regenerative energy that can be absorbed is decreased.

Note 2. For Servomotors with brakes, add the brake inertia to the load inertia.

Note 3. This is the applicable range for the horizontal shaft. (No external force should be applied.)

Range for Absorbing Regenerative Energy

The relationship between rotation speed and the load inertia that can be absorbed by a Servo Driver alone is shown in the diagrams below. If a Servo Driver is operated outside of this range, a Regeneration Unit must be connected. These diagrams show the applicable range for the horizontal shaft. If an external force acts in the same direction as the Servomotor rotation, due to factors such as the fall time on the vertical shaft, be sure to measure the regenerative energy and check to see that the amount that can be absorbed is not exceeded.

R88D-UP02H(A)/-UP03H(A)/-UP04H(A)/-UP02V/-UP03V/-UP04V (30 W, 50 W, 100 W)
 R88D-UP03L(A)/-UP04L(A)/-UP10L(A)/-UP03W/-UP04W/-UP10W (30 W, 50 W, 100 W)

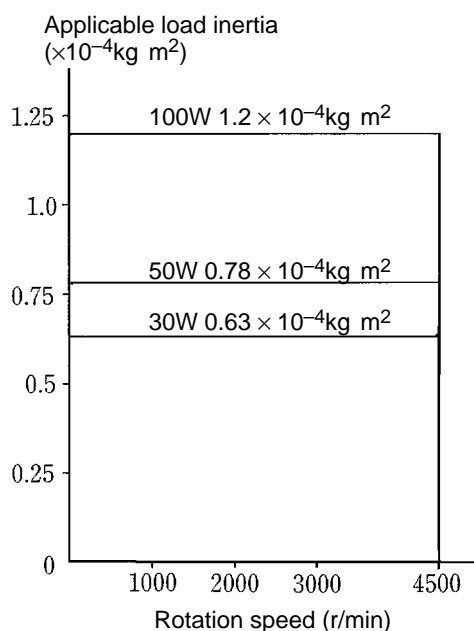

- R88D-UP08H(A)/-UP08V (200 W)
- R88D-UP12L(A)/-UP12W (200 W)

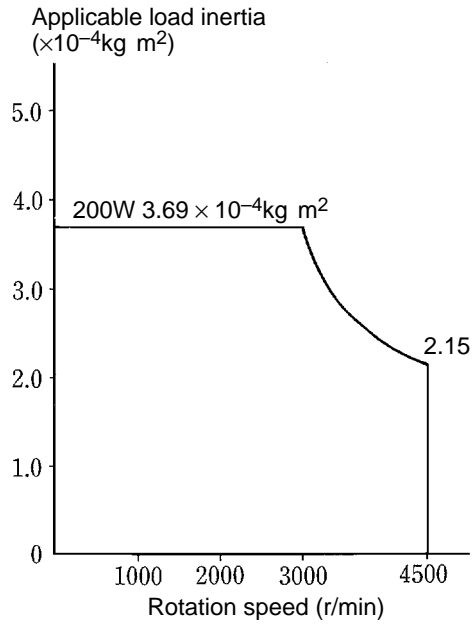

- R88D-UP12H(A)/-UP12V (400 W)
- R88D-UP15LA/-UP15W (300 W)

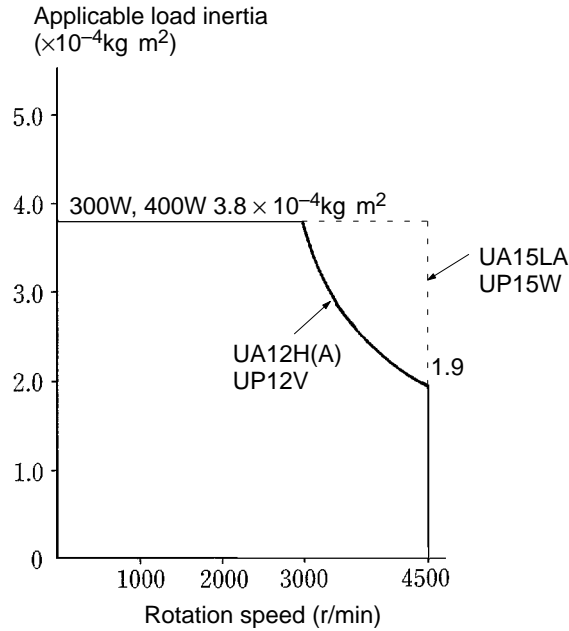

□ R88D-UP20H(A)/UP20V (750 W)

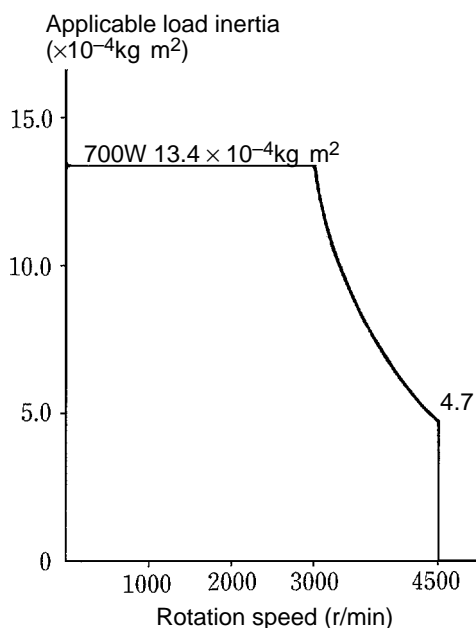

3-8-3 Absorption of Regenerative Energy with the External Regeneration Resistor (Models Conforming to UL/cUL Standards and Models Not Conforming to Any Standards)

Connect one or more external regeneration resistors when a Regeneration Unit (R88A-RG08UA) cannot absorb all of the regenerative energy. Remove the short bar from between the RG and JP terminals on the Regeneration Unit and connect the resistor between the P and RG terminals. Connecting to the wrong terminals may destroy the Regeneration Unit, so connect the resistor carefully. (The Regeneration Unit does not conform to EC Directives.)

The external regeneration resistor will heat to approximately 120 °C. Do not install it near devices or wiring that is sensitive to heat. Install heat radiation plates suitable to the radiation conditions.

External Regeneration Resistors

□ Models

Model	Resistance	Nominal capacity	Regeneration absorption at 120 °C	Heat radiation conditions	Thermal switch output specifications
R88A-RR22047S	47Ω ±5%	220 W	70 W	1.0 × 350 (SPCC)	Operating temperature: 170 °C±5% N.C. contact Rated output: 3 A

☐ Combining External Regeneration Resistors

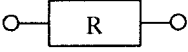
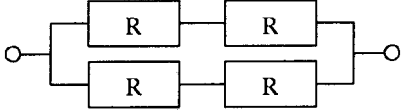
Item	Regeneration absorption capacity	
	70 W	280 W
Combining external regeneration resistors		

Note Use a combination with an absorption capacity larger than the average regenerative power (P_r).

☐ Dimensions (Unit: mm)

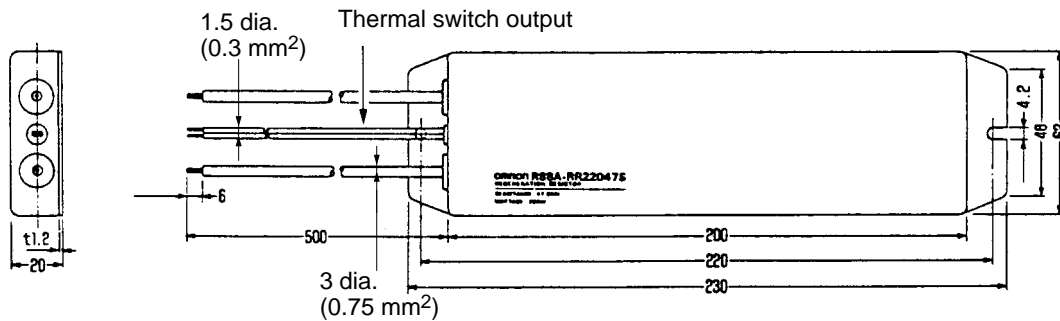

Wiring External Regeneration Resistors

Remove the short bar from between the RG and JP terminals on the Regeneration Unit and connect the resistor(s) between the P and RG terminals.

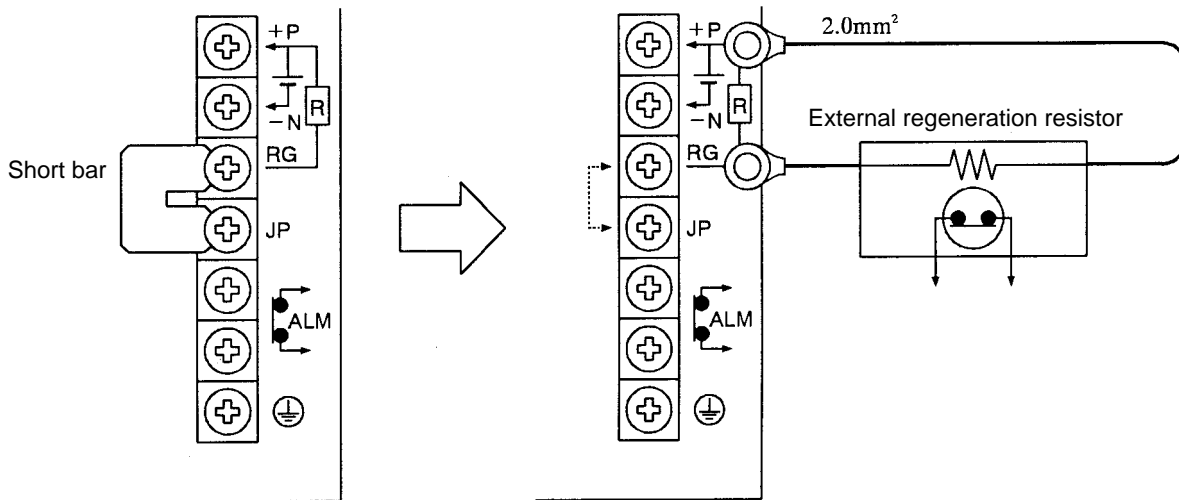

Note The thermal switch output must be connected in the same way as the ALM output from the Regeneration Unit, i.e., so that power supply is shut OFF when the contacts open. The resistor may be damaged if the thermal switch output is used without forming a power shut-off sequence.

3-8-4 Processing Regenerative Energy with Multiple Axes (Models Conforming to EC Directives)

When using multiple axes, the + terminals on the Servo Drivers can be connected together and the – terminals can be connected together to use regenerative energy as the drive energy for the other axes, thus absorbing the energy. Servo Drivers with different power supply voltages, however, cannot be connected. Also, regeneration absorption capacity will not be increased when all axes simultaneously produce regenerative energy.

Wiring Method (Example for 3 Axes)

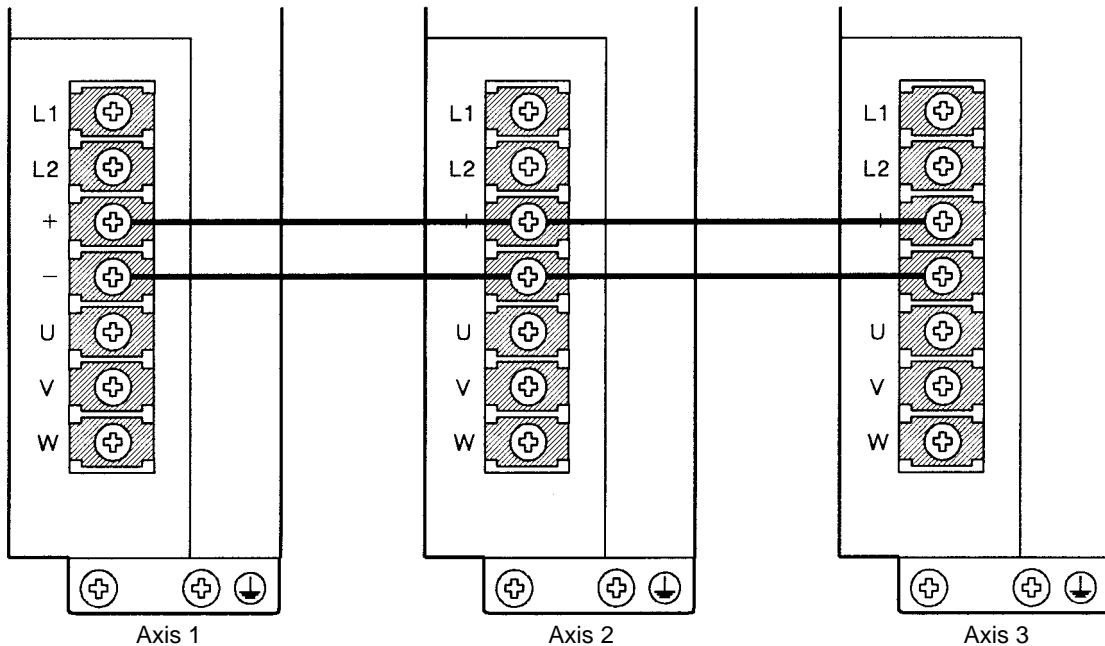

Note 1. Do not open or close the connections between the + or – terminals while power is being supplied. The Units may be destroyed.

Note 2. Do not connect Servo Drivers that are using different power supply voltages. The Units may be destroyed.

Regeneration absorption capacity will not be increased when all axes simultaneously produce regenerative energy. Take one or more of the following methods if this occurs.

- Reduce the number of rotations being used. (Regenerative energy is directly proportional to the square of the number of rotations.)
- Increase the deceleration time. (This will reduce the regenerative energy per unit time.)

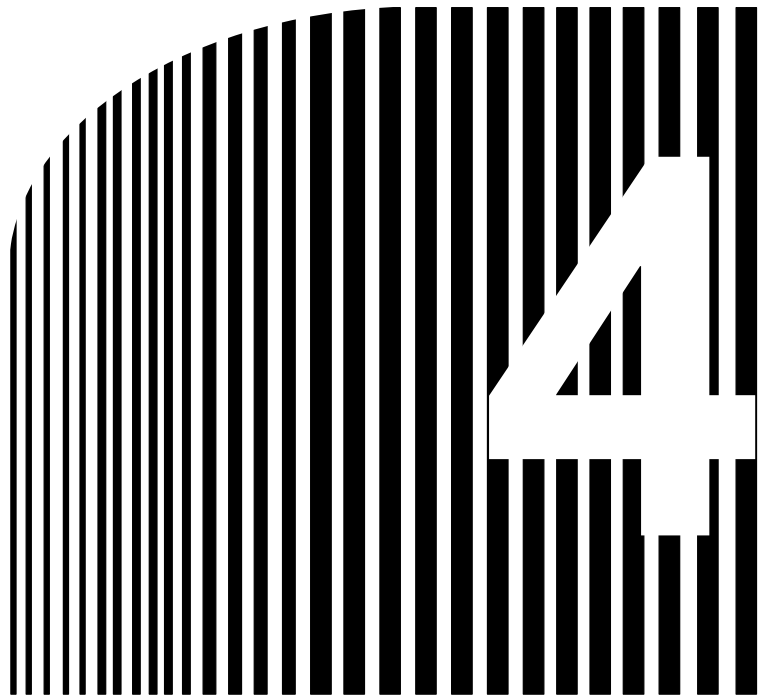

Chapter 4

• Application •

- 4-1 Using Displays
- 4-2 Using the Monitor Output
- 4-3 Protective and Diagnostic Functions
- 4-4 Troubleshooting
- 4-5 Periodic Maintenance

4-1 Using Displays

4-1-1 Display Functions

OMRON U-series AC Servomotors have unique servo software that enables quantitative monitoring in real time, on digital displays, of changes in a variety of characteristics. Use these displays for checking the various characteristics during operation.

□ Servo Driver Displays

There are two LED indicators on the Servo Driver itself. One is for the power supply and another is for alarms.

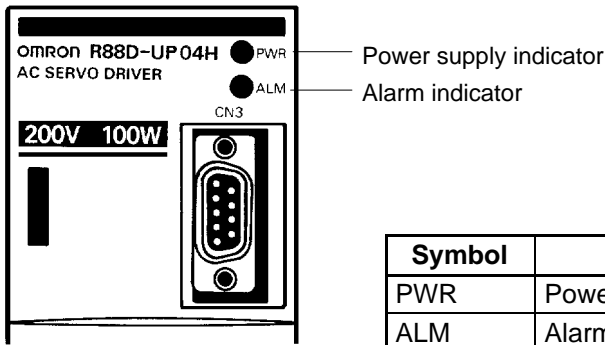

Symbol	Name	Function
PWR	Power supply indicator	Lit when AC power supply is normal.
ALM	Alarm indicator	Lit when error occurs.

If the alarm indicator is lit, connect a Parameter Unit and check the contents of the alarm.





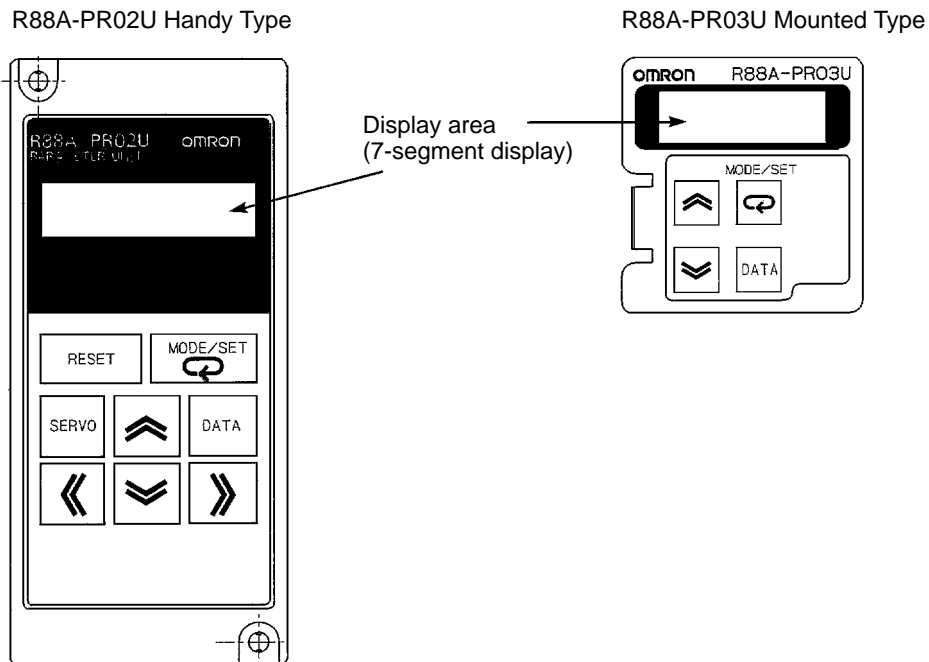









□ Parameter Unit Displays

When a Parameter Unit is connected, monitoring can be conducted by means of a 5-digit 7-segment LED.



Parameter Unit Key Functions

The contents displayed by the Parameter Unit can be changed by key operations.

Handy-type Parameter Unit R88A-PR02U	Mounted Parameter Unit R88A-PR03U	Function
		Alarm reset
		Mode switching; data memory
		Servo ON/OFF during jog operations
		Switching between parameter display and data display; data memory
		Increments parameter numbers and data values.
		Decrements parameter numbers and data values.
	---	Left shift for operation digits
	---	Right shift for operation digits

Types of Modes

There are four types of modes for Parameter Unit displays. The functions in each mode are shown in the following table.

Mode	Function
Status display mode	Bit display (indicating internal status via indicators): Power supply ON display, base block, positioning completed, rotation detection and current limit detection, command pulse input Symbol display (indicating internal status via 3-digit 7-segment display): Base block, operating, forward rotation prohibited, reverse rotation prohibited, alarm display
Settings mode	System check: Jog operations, alarm history data clear, motor parameters check, auto-tuning Setting and checking setup parameters Setting and checking user parameters
Monitor mode	Speed feedback, speed commands, torque commands, number of pulses from U-phase, electrical angle, internal status bit display, command pulse speed, position deviation, and input pulse counter (HA/LA/V/W Models)
Alarm history display mode	Displays contents of alarms that have been previously generated (up to a maximum of 10).

Changing the Mode

Use the MODE/SET Key to change from one mode to another.

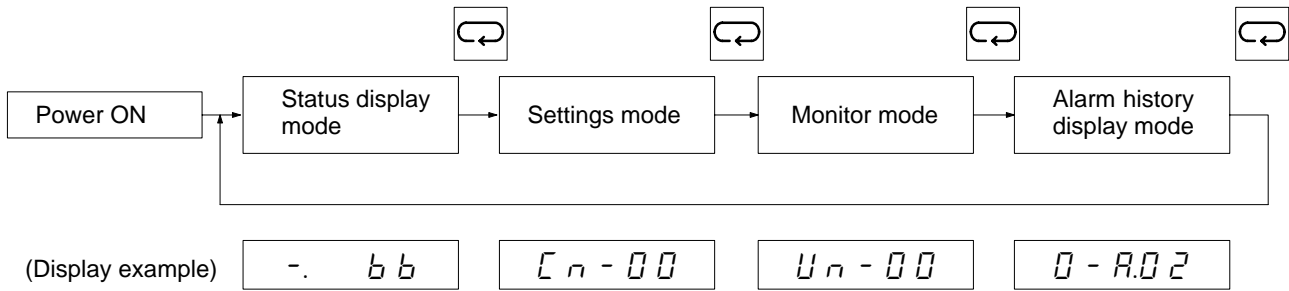

4-1-2 Status Display Mode

The status display mode is entered when powering up or by means of the MODE/SET Key. In the status display mode, Servo Driver status is displayed in two ways: bit data and symbols. These displays are shown in the following illustration.

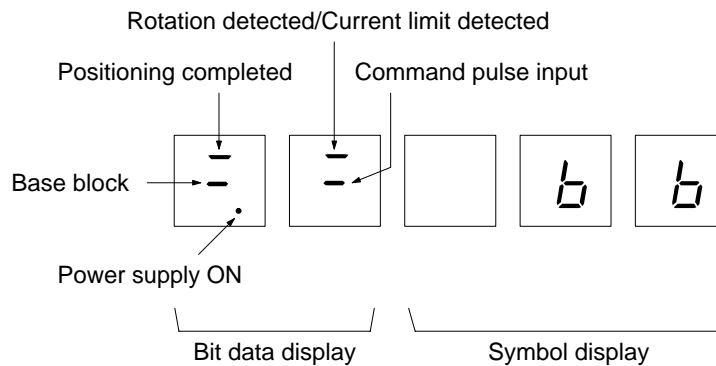

Bit Data Display Contents

Bit data	Contents
Power supply ON	Lit when Servo Driver power supply is ON.
Base block	Lit during base block (no power to motor); dimmed when servo is ON.
Positioning completed	Lit when the pulse count remaining on the deviation counter is equal to or less than the positioning completed range set in Cn-1b.
Rotation detection /current limit detection (See note.)	Lit when the motor rotational speed is equal to or greater than the rotational speed for motor rotation detection (Cn-0b). Lit when a torque command is limited by the torque limit value (Cn-08, 09 or Cn-18, 19).
Command pulse input	Lit when the specified command pulse is being input.

Note The setting of bit no. 4 in setup parameter no. 1 (Cn-01) determines whether rotation detection or current limit detection will be output.

Symbol Display Contents

Symbol display	Contents
<i>bb</i>	Base block (no power to motor)
<i>run</i>	Operating
<i>For</i>	Forward rotation prohibited
<i>Rev</i>	Reverse rotation prohibited
<i>Al.</i>	Alarm display (Refer to alarm table.)

4-1-3 Monitor Mode (Un-)

Types of Monitoring

In monitor mode, ten types of monitoring can be carried out.

Monitor no.	Monitor contents	Unit	Explanation
00	Speed feedback	r/min	Displays actual rotational speed of motor.
01	Speed command	r/min	Displays commands to speed loop when controlling via internally set speeds. "0" will be displayed when controlling with pulse trains.
02	Torque command	%	The command to the current loop is displayed as 100% of the rated torque.
03	Number of pulses from U-phase edge	Pulses	The number of pulses from the U-phase edge is displayed in units of encoder resolution. Displays pulse number with 1/4 turn being 2048 pulses (with an error of approx. ±5 pulses).
04	Electrical angle	Degrees	Displays the electrical angle of the motor.
05	Internal status bit display 1	---	Displays Servo Driver internal information as either lit or not lit.
06	Internal status bit display 2	---	
07	Command pulse speed display	r/min	Displays the command pulse counter converted to a frequency (r/min).
08	Position deviation (deviation counter)	Pulses	Displays the pulse count (position deviation) remaining on the deviation counter in command units (based on input pulses).
09	Input pulse counter	Command units	Counts and displays the input pulses. (HA/LA/V/W Models)

Operation in Monitor Mode

In order to conduct monitoring, first go into monitor mode and then set the monitor number and press the DATA Key. The items in parentheses in the following explanation indicate operations using the Handy-type Parameter Unit.

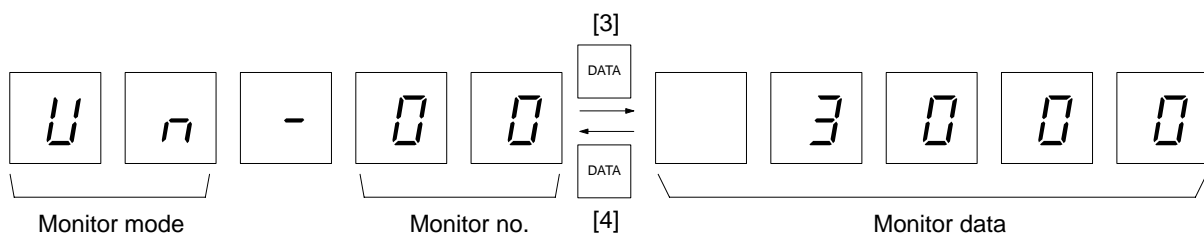

1. Press the MODE/SET Key to go into monitor mode.
2. Using the Up and Down (and Right and Left) Keys, set the monitor number.
3. Press the DATA Key to display the monitor data.
4. Press the DATA Key to return to the monitor number display.
5. Press the MODE/SET Key to move from monitor mode to alarm history display mode.

Internal Status Bit Display (Un-05, Un-06)

Internal status is displayed by 7-segment bit lighting. The bit number allocation is shown in the following diagram.

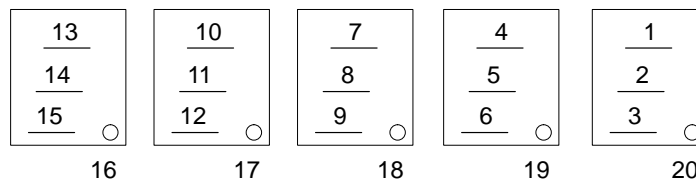

Monitor no.	Bit no.	Symbol	Contents
Un-05	1	ALM	Lit when alarm is generated.
	2	DBON	Lit during dynamic brake operation.
	3	DIR	Lit when in reverse rotation mode (when Cn-02 bit no. 0 = 1).
	4	TGON/ CLIMT	Lit when the motor rotational speed is equal to or greater than the rotational speed for motor rotation detection (Cn-0b). Lit when a torque command is limited by the torque limit value (Cn-08, 09 or Cn-18, 19).
	5	INP	Lit when the motor rotational speed reaches the speed command value.
	6	PCON	Lit when the speed control loop is in P control.
	7	PCL/SPD1	Lit when forward rotation current limit / speed selection command 1 (CN1-11) is ON.
	8	NCL/SPD2	Lit when reverse rotation current limit / speed selection command 2 (CN1-12) is ON.
	9	SVON	Lit when motor is receiving power.
	10	A	Encoder A phase (HA/LA/V/W Models: Lit when there is a signal; H/L Models: Dimmed when there is a signal)
	11	B	Encoder B phase (HA/LA/V/W Models: Lit when there is a signal; H/L Models: Dimmed when there is a signal)
	12	Z	Encoder Z phase (HA/LA/V/W Models: Lit when there is a signal; H/L Models: Dimmed when there is a signal)
	13	PU	Poll sensor U phase
	14	PV	Poll sensor V phase
	15	PW	Poll sensor W phase
	16	RUN	Lit when run command is ON.
	17	MING/ RDIR/IPG	Lit when CN1-15 is ON. (Input signal functions change according to parameter settings.)
	18	POT	Lit when forward drive prohibit input is ON.
	19	NOT	Lit when reverse drive prohibit input is ON.
	20		Not used
Un-06	1	CW	Lit when clockwise command pulses are being input.
	2	CCW	Lit when counterclockwise command pulses are being input.
	3	ECRST	Lit when the deviation counter reset input is ON.
	4 to 20		Not used

4-1-4 Checking Servomotor Parameters (Cn-00 Set to 04)

Servomotor parameters can be checked when system check mode Cn-00 is set to "04." Servomotor parameters are the Servomotor specifications that can be controlled by that Servo Driver. They are not the specifications of the Servomotor that is connected. Use this to check whether the Servo Driver and Servomotor combination is suitable.

□ Servomotor Parameter Checking Operation

The items in parentheses in the following explanation indicate operations using the Handy-type Parameter Unit.

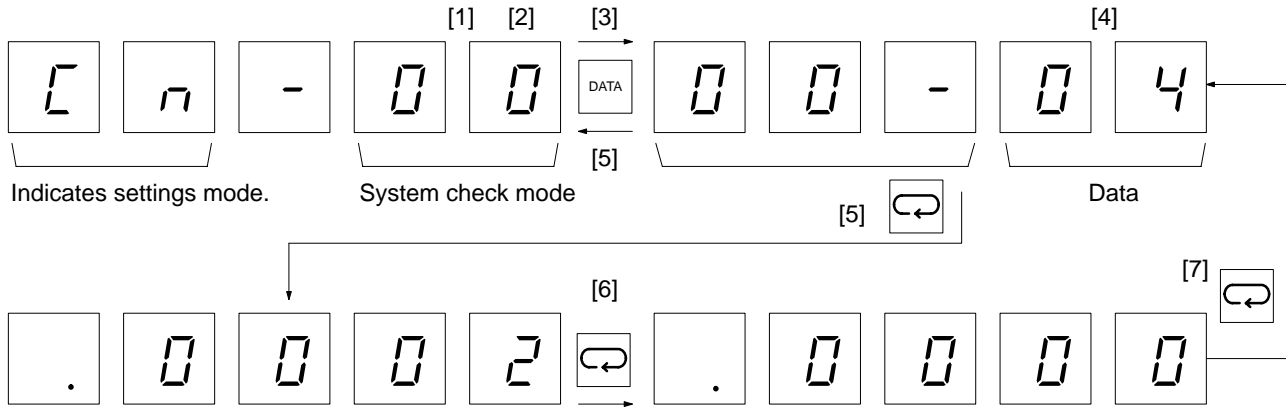

1. Press the MODE/SET Key to switch to the settings mode.
2. Using the Up and Down Keys, set parameter number "00." (System check mode)
3. Press the DATA Key to display the setting of Cn-00.
4. Using the Up and Down Keys, change the setting to "04." (Servomotor parameter check)
5. Press the MODE/SET Key, and check the Servomotor parameters in order.
6. Press the MODE/SET Key to display special specifications in hexadecimal.
7. Press the MODE/SET Key to return to the data display for the system check mode.

□ Parameter Display Contents

Servomotor Parameters

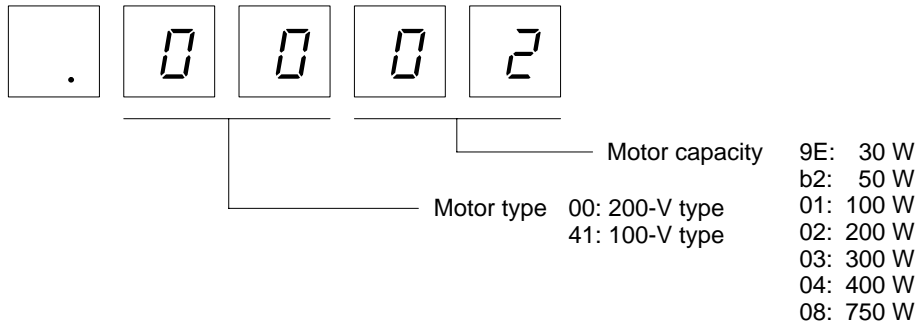

Special Specifications

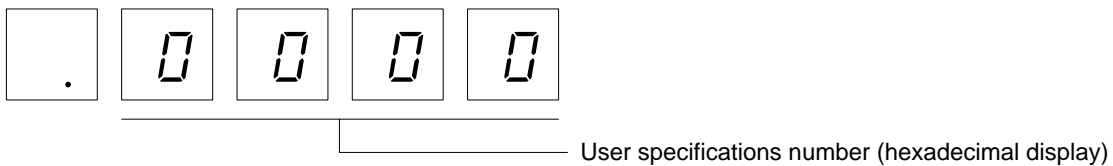

4-2 Using the Monitor Output

The Servo Drive outputs a monitor voltage proportional to the Servomotor rotation speed and current from the monitor output connector (CN4) on the top of the Servo Driver. This output can be used to install a meter in the control panel or to enable more precise gain adjustments.

□ Analog Monitor Output Specifications

Monitor Output Terminals (Top of the Servo Driver)

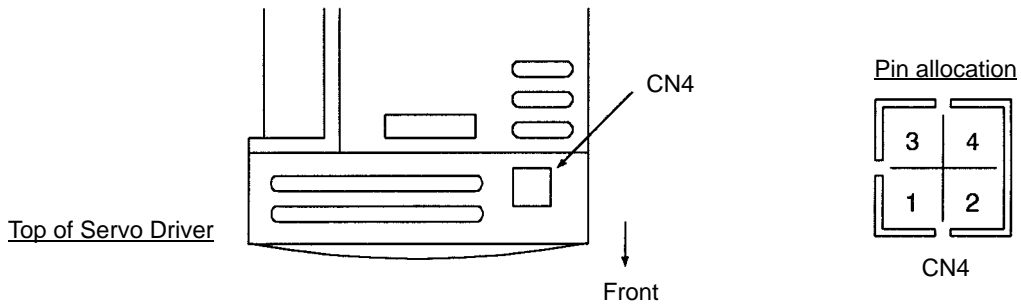

Monitor Output Circuit

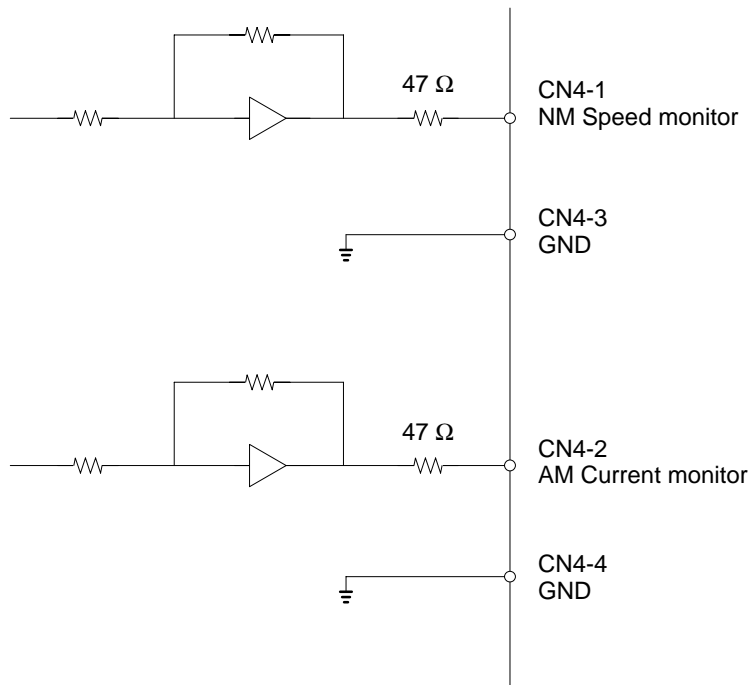

Monitor Output Specifications

Speed monitor	With 0 V as center, voltage output at 0.5 V/(1000 r/min) ratio. Forward rotation: (-) voltage; reverse rotation: (+) voltage Output accuracy: approximately ±10%
Current monitor	With 0 V as center, voltage output at 0.5 V/(rated torque) ratio. Forward acceleration: (-) voltage; reverse acceleration: (+) voltage Output accuracy: approximately ±10%

□ Analog Monitor Cable (R88A-CMW001S)

Use this cable to connect the Servo Driver's Analog Monitor Connector.

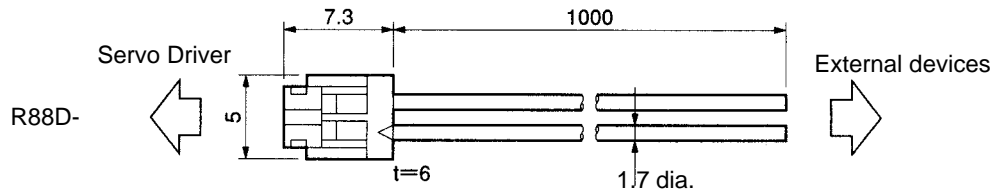

Servo Driver

Symbol	No.
NM	1
AM	2
GND	3
GND	4

- Red Connector socket model
- White DF11-4DS-2C (Hirose)
- Black Connector socket model
- Black DF11-2428SCF (Hirose)

Cable: AWG24 x 4C UL1007

4-3 Protective and Diagnostic Functions

4-3-1 Alarm Displays and Alarm Code Outputs

The Servo Driver has the error detection functions shown below. When an error is detected, the alarm output (ALM) and the alarm code output (AL01-03) are output, the Servo Driver's internal power drive circuit is turned off, and the alarm is displayed.

□ Alarm Table

Dis-play	Alarm code			Alarm ALM	Error detection function	Detection contents
	AL01	AL02	AL03			
R.02	OFF	OFF	OFF	OFF	Parameter corruption	The checksum for the parameters read from the EEPROM does not match.
R.04	OFF	OFF	OFF	OFF	Parameter setting error	Incorrect parameter setting. (HA/LA/V/W Models)
R.10	ON	OFF	OFF	OFF	Overcurrent	Overcurrent or overheating detected.
R.31	ON	ON	OFF	OFF	Deviation counter overflow	The pulses remaining on the deviation counter exceed the deviation counter overflow level set in Cn-1E.
R.40	OFF	OFF	ON	OFF	Overvoltage	Main circuit DC voltage exceeded the allowable value.
R.51	ON	OFF	ON	OFF	Over speed	Detected at 4,950 r/min.
R.52	ON	OFF	ON	OFF	Excessive speed command input	Speed command for 4,700 r/min was input. (H/L Models)
R.70	ON	ON	ON	OFF	Overload	Detected at reverse limit characteristics when the output torque exceeds 120% of the rated torque. (HA/LA/V/W Models)
R.71	ON	ON	ON	OFF	Overload	Detected at reverse limit characteristics when 135% of the rated torque was exceeded. (H/L Models)
R.72	ON	ON	ON	OFF	Overload	Detected at reverse limit characteristics for 120% to 135% of the rated torque. (H/L Models)
R.C1	ON	OFF	ON	OFF	Runaway detected.	Faulty power or encoder wiring.
R.C2	ON	OFF	ON	OFF	Phase error detected.	Connector not properly connected. Encoder not properly wired.
R.C3	ON	OFF	ON	OFF	Encoder A or B phase wire disconnection.	Either Phase A or Phase B signal was disconnected or short circuited.
R.C4	ON	OFF	ON	OFF	Encoder S phase wire disconnection.	Encoder S phase was disconnected or short circuited.
R.3	OFF	ON	OFF	OFF	Momentary power failure alarm	The power supply was re-started within the power retention period.
R.99	OFF	OFF	OFF	ON	Alarm reset power supply turned on.	This is history data only, and is not an alarm.
CP 00	OFF	OFF	OFF	OFF	Parameter Unit transmission error 1	Data could not be transmitted after the power supply was turned on. (It no longer exists in the alarm history.)
CP 01	---	---	---	---	Parameter Unit transmission error 2	Transmission timeout error (It no longer exists in the alarm history.)

Note “---” means indefinite.

4-3-2 Alarm Output

This section describes the timing of alarm outputs when power is turned on and when alarms occur. The method used to clear alarms is also described.

□ Timing Chart

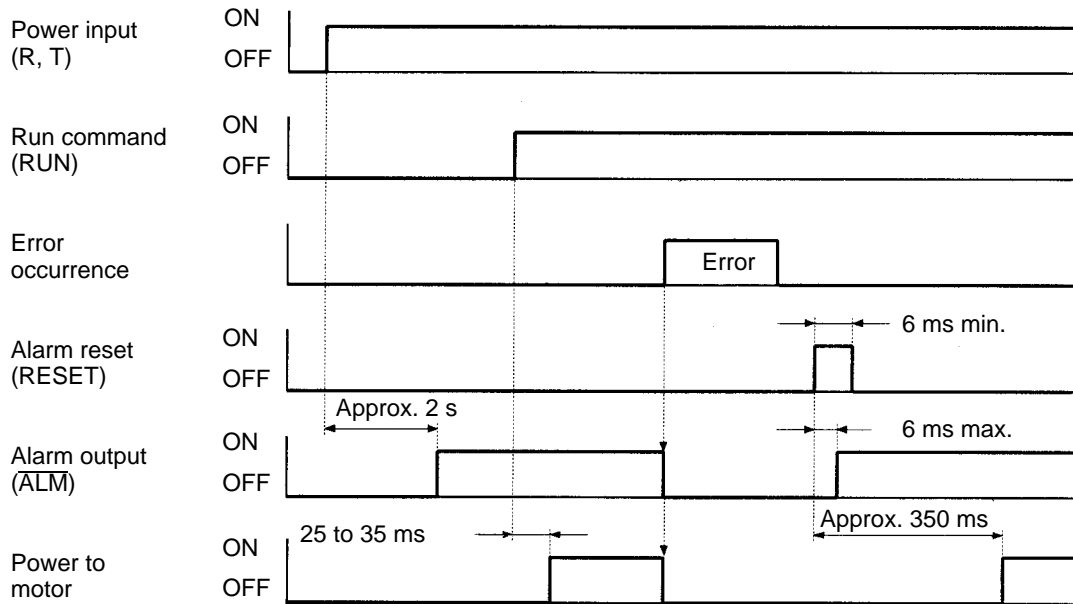

□ Alarm Output Circuit

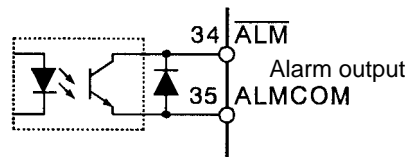

Output specifications: 30 VDC, 50 mA max.
 Normal: Output transistor ON
 Error (alarm): Output transistor OFF

□ Clearing Alarms

- Any of the following methods can be used to clear alarms:
 - Turn ON the alarm reset signal (RESET).
 - Toggle the power supply.
 - Press the Reset Key on the Parameter Unit.

Overcurrent alarms (A.10), however, cannot be cleared by toggling the power supply.

- Operation will start as soon as the alarm is cleared if the alarm is cleared while the Run command (RUN) is ON, possibly creating a dangerous situation. Turn OFF the Run command before clearing alarms. Take adequate safety precautions if an alarm is going to be cleared while the Run command is ON or when the Servo Always ON (Cn-01, bit 0 set to 1) is used.

4-3-3 Overload Characteristics (Electron Thermal Characteristics)

An overload protection function (electron thermal) is built into the Servo Driver to protect against Servo Driver or Servomotor overload. If an overload (A.70 to A.72) does occur, first clear the cause of the error and then wait at least one minute for the Servomotor temperature to drop before turning on the power again. If the power is turned on again too soon, the Servomotor coil may be damaged.

□ Overload Characteristic Graph

The characteristic between the load ratio and the electronic thermal operating time is shown in the following graph.

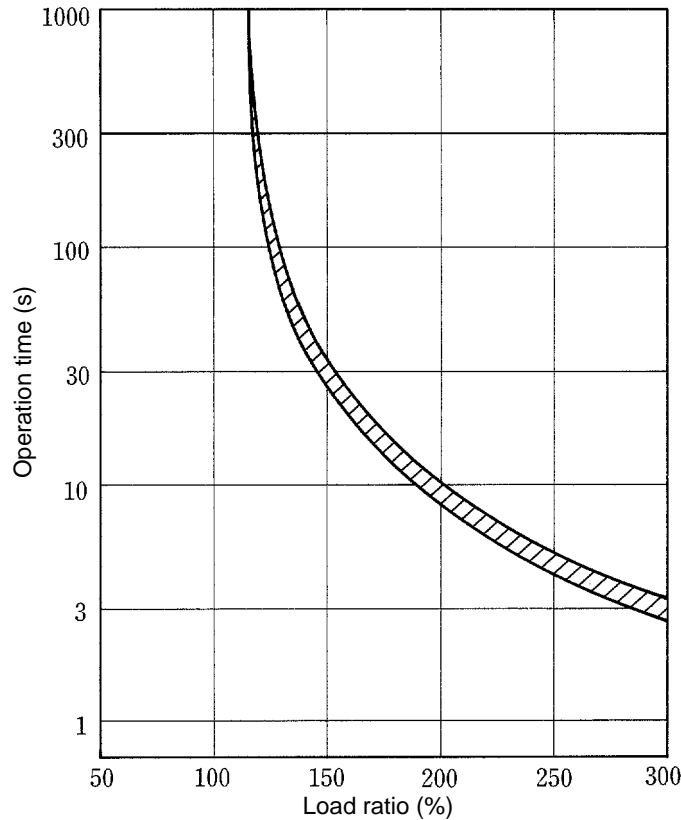

Note 1. The load ratio is calculated in relation to the Servomotor's rated current.

$$\text{Load ratio (\%)} = \frac{\text{Servomotor current}}{\text{Servomotor rated current}} \times 100$$

Note 2. For example, if a current three times the rated motor current is applied continuously, and overload will be detected in approximately 3 s.

4-3-4 Alarm History Display Mode

The Servo Driver stores the history of the 10 most recent alarms that have been generated. The alarm history can be displayed by going into the alarm history display mode and using the Up and Down Keys.

To clear the alarm history, set the system check mode to “02” and press the MODE/SET Key.

□ Displaying the Alarm History

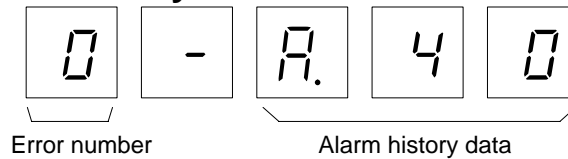

1. Confirm that the initial display is shown (-. bb).
2. Press the MODE/SET Key to go to the alarm history display mode.
3. Use the Up and Down Keys to go up and down through the error occurrence numbers and display the corresponding alarm history data. (The larger the error occurrence number, the less recent the alarm is.)

□ Clearing Alarm History Data

Alarm history data initialization is executed in the system check mode. The items in parentheses in the following explanation indicate operations using the Handy-type Parameter Unit.

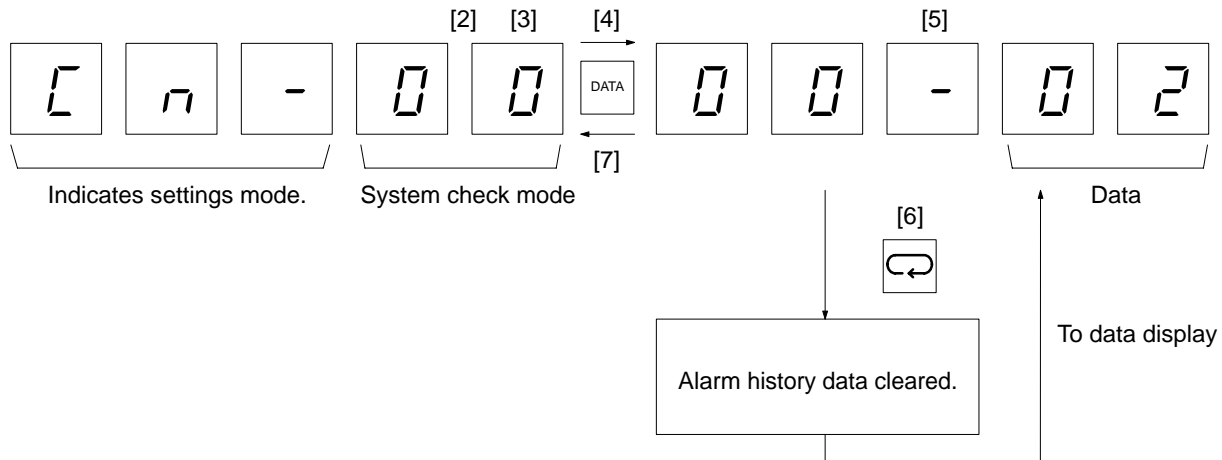

1. Confirm that the initial display is shown (-. bb).
2. Press the MODE/SET Key to enter the settings mode.
3. Using the Up and Down Keys, set parameter number “00.” (System check mode)
4. Press the DATA Key to display the setting of Cn-00.
5. Using the Up and Down Keys, set the parameter to “02.” (Alarm history clear)
6. Press the MODE/SET Key to clear the alarm history data.
7. Press the DATA Key to return to the settings mode.

4-4 Troubleshooting

When an error occurs, check the error contents by means of the operating status and alarm display, investigate the cause and apply the appropriate countermeasures.

□ Error Diagnosis by Means of Operating Status

Symptom	Probable cause	Items to check	Countermeasures
The power supply indicator (PWR) does not light even when the power supply is turned on.	Power supply lines are incorrectly wired.	<ul style="list-style-type: none"> Check the power supply voltage. Check the power supply lines. 	<ul style="list-style-type: none"> Correct the power supply. Correct the wiring.
The motor does not operate even when command pulses are input. (No alarm is output.)	The RUN signal is OFF (when Cn-01 bit no. 0 is "0").	Check the RUN signal's ON and OFF by means of the monitor mode.	<ul style="list-style-type: none"> Input the RUN signal. Correct the wiring.
	The correspondence between the Servo Driver and the Servomotor is incorrect.	Check the models.	Combine models that correspond correctly.
	The POT and NOT signals are OFF (when Cn-01 bit nos. 2 and 3 are "0").	Check whether POT and NOT are displayed in status display mode.	<ul style="list-style-type: none"> Turn ON the POT and NOT signals. If POT and NOT are not being used, set Cn-01 bit nos. 2 and 3 to "1."
	The mode is the internal speed control setting mode.	Check Cn-02 bit no. 2.	Set Cn-02 bit no. 2 to "0" unless internally set speed control is being used.
	The deviation counter reset input (ECRST) is ON.	Check the deviation counter reset signal in monitor mode (internal status bit display).	<ul style="list-style-type: none"> Turn OFF the ECRST signal. Correct the wiring.
	An error occurred with the RESET signal ON.	Check the RESET signal's ON and OFF by means of the monitor mode.	Turn the RESET signal OFF and take measures according to the alarm display.
	The setting for the command pulse mode is not correct (Cn-02 bits 3, 4, 5).	Check positioner's command pulse type and Driver's command pulse mode.	Set according to the controller command pulse type.
The motor operates momentarily, but then it does not operate.	The setting for the number of encoder pulses is incorrect.	Check whether Cn-11 is "2048."	Set Cn-11 to "2048."
	The Servomotor power lines or encoder lines are wired incorrectly.	Check the Servomotor power line U, V, and W phases, and the encoder line wiring.	Correct the wiring.

Symptom	Probable cause	Items to check	Countermeasures
Servomotor operation is unstable.	The Servomotor power lines or encoder lines are wired incorrectly.	Check the Servomotor power line U, V, and W phases, and the encoder line wiring.	Correct the wiring.
	The settings for the bias function are not correct.	---	Adjust bias revolutions and positioning completed range.
	There are eccentricities or looseness in the coupling connecting the Servomotor shaft and the mechanical system, or there are load torque fluctuations according to how the pulley gears are engaging.	<ul style="list-style-type: none"> • Check the machinery. • Try operating the Servomotor without a load. 	Adjust the machinery.
	Gain is wrong.	---	<ul style="list-style-type: none"> • Use auto-tuning. • Adjust the gain manually.
Servomotor is overheating.	The ambient temperature is too high.	Check to be sure that the ambient temperature around the Servomotor is no higher than 40°C.	Lower the ambient temperature to 40°C or lower. (Use a cooler or fan.)
	Ventilation is obstructed.	Check to see whether anything is blocking ventilation.	Ensure adequate ventilation.
	There is an overload.	Check the torque command value by means of monitor mode.	<ul style="list-style-type: none"> • Lighten the load. • Change to a larger capacity Servomotor.
	The correspondence between the Servo Driver and the Servomotor is incorrect.	Check the models.	Combine models that correspond correctly.
There are unusual noises.	The machinery is vibrating.	Inspect the machinery to see whether there are any foreign objects in the movable parts, or whether there is any damage, deformation, or looseness.	Fix any problems causing vibration.
	The speed loop gain adjustment is insufficient.	---	<ul style="list-style-type: none"> • Use auto-tuning. • Adjust the gain manually (speed loop gain).
Vibration is occurring at the same frequency as the applicable power supply.	Inductive noise is occurring.	<ul style="list-style-type: none"> • Check to see whether the Servo Driver control signal lines are too long. • Check to see whether control signal lines and power supply lines are too close to each other. 	<ul style="list-style-type: none"> • Shorten the control signal lines. • Separate control signal lines from power supply lines. • Use a low-impedance power supply for control signals.

Error Diagnosis by Means of Alarm Display (Parameter Unit)

Alarm display	Error content	Condition when error occurred	Probable cause	Countermeasures
<i>A.02</i>	Parameter corruption	Occurred when power was turned on.	Internal memory error	Replace Servo Driver.
<i>A.04</i>	Parameter setting error (HA/LA/V/W Models)	Occurred when power was turned on.	A user parameter was set to a value outside of the setting range previously.	Change the user parameter setting so it is within the setting range.
		Occurred after auto-tuning was executed	Control board defective. The compensating gain (Cn-28) was set a value other than 0 when auto-tuning was executed.	Replace Servo Driver. Using the Handy-type Parameter Unit, set Cn-04 and Cn-05 to their factory default values, set Cn-28 to 0, then execute auto-tuning.
<i>A.10</i>	Overcurrent	Occurred when power was turned on.	Control board defective.	Replace Servo Driver.
		Occurred when Servo was turned on.	<ul style="list-style-type: none"> • Current feedback circuit error • Main circuit transistor module error 	Replace Servo Driver.
			Servomotor power line is short-circuited or grounded.	<ul style="list-style-type: none"> • Correct the power line short-circuiting or grounding. • Measure the insulation resistance at the Servomotor itself. If there is short-circuiting, replace the Servomotor.
			There is faulty wiring at the U, V, or W phase, or the GR.	Correct the wiring.
			Servomotor coil are damaged.	Measure the winding resistance. If the coil are damaged, replace the Servomotor.
	Overheating	Occurred during operation. Occurred even though power was on. If reset is executed after waiting for a time, operation resumes.	The ambient temperature for the Servo Driver is higher than 55°C.	Bring the ambient temperature for the Servo Driver down to 55°C or lower.
		The load torque is too high.	<ul style="list-style-type: none"> • Lighten the load. • Lengthen the acceleration time. • Select another Servomotor. 	

Alarm display	Error content	Condition when error occurred	Probable cause	Countermeasures
R.31	Deviation counter overflow	Occurred when Servomotor did not operate even when command pulse train was input.	Servomotor power lines or encoder lines are wired incorrectly.	Correct the wiring.
			The Servomotor is mechanically locked.	Unlock the Servomotor shaft.
		Occurred at high-speed operation.	Servomotor power lines or encoder lines are wired incorrectly.	Correct the wiring.
		Occurred when a long command pulse was given.	The gain adjustment is insufficient.	Adjust the gain.
			The acceleration/deceleration times are too extreme.	Lengthen the acceleration/deceleration time.
			The load is too large.	<ul style="list-style-type: none"> • Lighten the load. • Select another Servomotor.
			Cn-1E (deviation counter overtravel) is too small.	Increase Cn-1E.
R.40	Overvoltage	Occurred when power was turned on.	The power supply voltage is outside of the allowable range.	<ul style="list-style-type: none"> • The supply voltage must be 170 to 253 VAC when 200 VAC is specified. • The supply voltage must be 85 to 127 VAC when 100 VAC is specified.
			Occurred during Servomotor deceleration.	The load inertia is too large.
		Occurred while lowering (vertical shaft)	The power supply voltage is outside of the allowable range.	<ul style="list-style-type: none"> • The supply voltage must be 170 to 253 VAC when 200 VAC is specified. • The supply voltage must be 85 to 127 VAC when 100 VAC is specified.
			Regeneration Unit error	Replace the Regeneration Unit
		Gravity torque is too large.	<ul style="list-style-type: none"> • Add a counterbalance to the machine, and reduce the gravity torque. • Reduce the lowering speed. • Connect a Regeneration Unit. 	
R.51	Over speed	High-speed rotation occurred when command was input.	The rotational speed exceeded 4,950 r/min due to overshooting.	<ul style="list-style-type: none"> • Adjust the gain. • Lower the maximum speed of the command.
			Encoder is wired incorrectly.	Correct the wiring.
R.52	Excessive speed command input (H/L Models)	High-speed rotation occurred when command was input.	A speed command exceeding 4,700 r/min was input.	<ul style="list-style-type: none"> • Lower the command pulse frequency. • Reduce the electronic gear ratio or increase the command pulses.

Alarm display	Error content	Condition when error occurred	Probable cause	Countermeasures
A.70 A.71 A.72	Overload	Occurred during operation.	Operating at more than 120% of the rated torque. (A.70) HA/LA/V/W Models	<ul style="list-style-type: none"> • If the Servomotor shaft is locked, unlock it. • If Servomotor power lines are incorrectly wired, correct them. • Lighten the load. • Lengthen the acceleration time. • Adjust the gain. • The supply voltage must be 170 to 253 VAC when 200 VAC is specified. • The supply voltage must be 85 to 127 VAC when 100 VAC is specified.
			Operating at more than 135% of the rated torque. (A.71) H/L Models	
			Operating at 120% to 135% of the rated torque. (A.72) H/L Models	
			Power supply voltage dropped.	
A.80	Encoder error	Occurred when the power was turned on.	Cn-01 bit no. E is set to "1."	Set Cn-01 bit No. E to "0."
A.C1	Runaway detected	Some movement occurred at the beginning of operation.	<ul style="list-style-type: none"> • Encoder lines wired incorrectly. • Servomotor power lines wired incorrectly. 	Correct the wiring.
A.C2	Phase error detected	Some movement occurred at the beginning of operation.	<ul style="list-style-type: none"> • Encoder lines disconnected. • Connector contact faulty. 	<ul style="list-style-type: none"> • Correct the wiring. • Insert the connectors correctly.
		Occurred when the power was turned on.	Cn-01 bit no. E is set to "1."	Set Cn-01 bit No. E to "0."
A.C3	Encoder A, B phase wire disconnection.	Some movement occurred at the beginning of operation.	<ul style="list-style-type: none"> • Encoder lines disconnected. • Connector contact faulty. 	<ul style="list-style-type: none"> • Correct any disconnected lines. • Insert connectors correctly.
			Encoder lines wired incorrectly.	Correct the wiring.
			Encoder defective.	Replace the Servomotor.
			Servo Driver defective.	Replace Servo Driver.
		Occurred when the power was turned on.	Cn-01 bit no. E is set to "1."	Set Cn-01 bit No. E to "0."
A.C4	Encoder S phase wire disconnection.	Some movement occurred at the beginning of operation.	<ul style="list-style-type: none"> • Encoder lines disconnected. • Connector contact faulty. 	<ul style="list-style-type: none"> • Correct any disconnected lines. • Insert connectors correctly.
			Encoder lines wired incorrectly.	Correct the wiring.
			Encoder defective.	Replace the Servomotor.
			Servo Driver defective.	Replace Servo Driver.
		Occurred when the power was turned on.	Cn-01 bit no. E is set to "1."	Set Cn-01 bit No. E to "0."
A.3	Momentary power failure alarm		<ul style="list-style-type: none"> • A momentary power failure occurred. • The power supply was restarted within the power retention period. 	<ul style="list-style-type: none"> • Reset and then run again. • Set Cn-01 bit no. 5 to "1" to automatically clear the alarm when the power is restored after a momentary power failure.

Alarm display	Error content	Condition when error occurred	Probable cause	Countermeasures
EP 00	Parameter Unit transmission error 1	Occurred when power was turned on.	• Connector contact faulty.	• Insert connectors correctly.
			• Internal element is malfunctioning.	• Reset and operate again.
			• Servo Driver defective.	• Replace the Servo Driver.
			• Parameter Unit is defective. • Cable is broken (R88A-PR02U).	• Replace the Parameter Unit.
EP 01	Parameter Unit transmission error 2	Occurred while the Parameter Unit was being used.	• Connector contact faulty.	• Insert connectors correctly.
			• Internal element is malfunctioning.	• Reset and operate again.
			• Internal element is damaged.	• Replace the Servo Driver.
			• Cable is broken (R88A-PR02U).	• Replace the Parameter Unit.

4-5 Periodic Maintenance

⚠ WARNING Do not attempt to disassemble, repair, or modify any Units. Any attempt to do so may result in malfunction, fire, or electric shock.

⚠ Caution Resume operation only after transferring to the new Unit the contents of the data required for operation. Not doing so may result in an unexpected operation.

Servo Motors and Drives contain many components and will operate properly only when each of the individual components is operating properly. Some of the electrical and mechanical components require maintenance depending on application conditions. In order to ensure proper long-term operation of Servo Motors and Drivers, periodic inspection and part replacement is required according to the life of the components.

The periodic maintenance cycle depends on the installation environment and application conditions of the Servo Motor or Driver. Recommended maintenance times are listed below for Servo Motors and Drivers. Use these as reference in determining actual maintenance schedules.

Servo Motors

- Recommended Periodic Maintenance

 - Oil Seal: 2,000 hours

 - Bearings: 20,000 hours

Application Conditions: Ambient motor operating temperature of 40 °C, within allowable shaft load, rated operation (rated torque and r/m), installed as described in operation manual.

- The radial loads during operation (rotation) on timing pulleys and other components contacting belts is twice the still load. Consult with the belt and pulley manufacturers and adjust designs and system settings so that the allowable shaft load is not exceeded even during operation. If a motor is used under a shaft load exceeding the allowable limit, the motor shaft can break, the bearings can burn out, and other problems can occur.

Servo Driver and Regeneration Units

- Recommended Periodic Maintenance

 - Aluminum electrolytic capacitors: 50,000 hours

Application Conditions: Ambient driver (regeneration unit) operating temperature of 55 °C, rated operation (rated torque), installed as described in operation manual.

- The life of aluminum electrolytic capacitors is greatly affected by the ambient operating temperature. Generally speaking, an increase of 10 °C in the ambient operating temperature will reduce capacitor life by 50%. We recommend that ambient operating temperature be lowered and the power supply time be reduced as much as possible to lengthen the maintenance times for Servo Drivers and Regeneration Units.
- It is recommended that the Servo Driver and Regeneration Unit be inspected at five-year intervals if they are used under conditions worse than the above or not used over a long time of time. Contact your OMRON representative for inspection and the necessity of any component replacement.

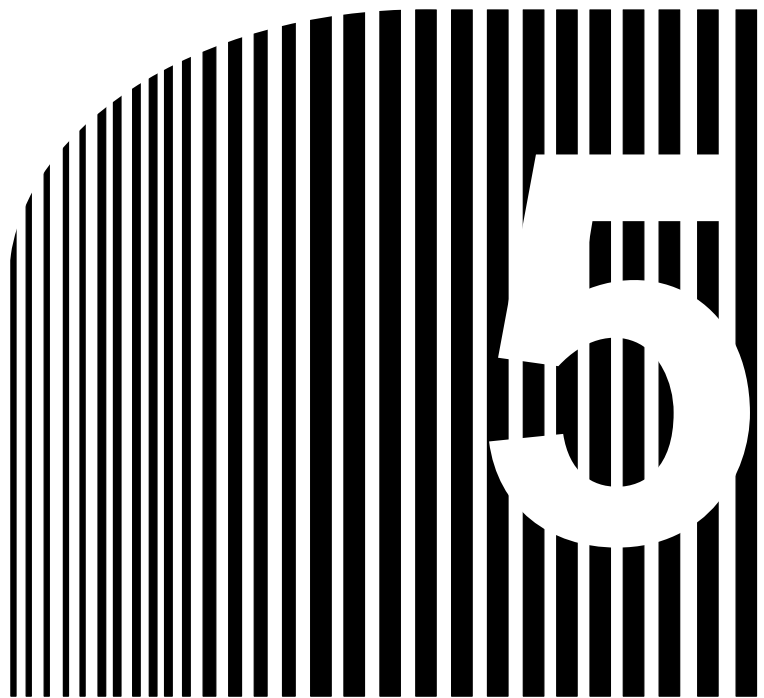

Chapter 5

• Specifications •

- 5-1 Servo Driver Specifications
- 5-2 Servomotor Specifications
- 5-3 Cable Specifications
- 5-4 Parameter Unit Specifications
- 5-5 Regeneration Unit Specifications
- 5-6 Front-surface Mounting Bracket Specifications

5-1 Servo Driver Specifications

5-1-1 General Specifications

Item	Specifications
Operating ambient temperature	0°C to 55°C
Operating ambient humidity	35% to 85% RH (with no condensation)
Storage ambient temperature	-10°C to 75°C
Storage ambient humidity	35% to 85% RH (with no condensation)
Storage and operating atmosphere	No corrosive gasses.
Vibration resistance	10 to 55 Hz in X, Y, and Z directions with 0.10-mm double amplitude; acceleration: 4.9 m/s ² max.; time coefficient: 8 min; 4 sweeps
Impact resistance	Acceleration 19.6 m/s ² max., in X, Y, and Z directions, three times
Insulation resistance	Between power line terminals and case: 5 MΩ min. (at 1,000 VDC)
Dielectric strength	Models Conforming to UL/cUL Standards and Models Not Conforming to Any Standards Between power line terminals and case: 1,000 VAC for 1 min (20 mA max.) at 50/60 Hz Models Conforming to EC Directives Between power line terminals and case: 1,500 VAC for 1 min at 50/60 Hz
Protective structure	Built into panel.

- Note 1.** The above items reflect individual evaluation testing. The results may differ under compounded conditions.
- Note 2.** Absolutely do not conduct a withstand voltage test or a megger test on the Servo Driver. If such tests are conducted, internal elements may be damaged.
- Note 3.** Depending on the operating conditions, some Servo Driver parts will require maintenance. Refer to *4-5 Periodic Maintenance* for details.
- Note 4.** The service life of the Servo Driver is 50,000 hours at an average ambient temperature of 55°C (at the rated torque and the rated rotation speed).

5-1-2 Performance Specifications

200-VAC Input Servo Drivers Conforming to UL/cUL Standards and 200-VAC Input Servo Drivers Not Conforming to Any Standards

Item	R88D-UP02H(A)	R88D-UP03H(A)	R88D-UP04H(A)	R88D-UP08H(A)	R88D-UP12H(A)	R88D-UP20H(A)
Continuous output current (0-P)	0.6 A	0.85 A	1.2 A	2.8 A	3.7 A	6.2 A
Momentary max. output current (0-P)	1.8 A	2.7 A	4.0 A	8.5 A	11.3 A	19.7 A
Input power supply	Single-phase 200/230 VAC (170 to 253 V) 50/60 Hz					
Control method	All-digital servo					
Speed feedback	Optical encoder, 2,048 pulses/revolution					
Applicable load inertia	Maximum of 30 times motor's rotor inertia				Maximum of 20 times motor's rotor inertia	
Inverter method	PWM method based on IGBT					
PWM frequency	11 kHz					7.8 kHz
Applicable Servomotor	R88M-U03030H(A)	R88M-U05030H(A)	R88M-U10030H(A)	R88M-U20030H(A)	R88M-U40030H(A)	R88M-U75030H(A)
Applicable Servomotor wattage	30 W	50 W	100 W	200 W	400 W	750 W
Cable length between motor and driver	20 m max.					
Weight (approximate)	0.9 kg				1.2 kg	1.5 kg
Heating value	15 W	18 W	20 W	35 W	45 W	60 W
Capacity	Maximum pulse frequency	200 kpps				
	Position loop gain	0 to 500 (1/s)				
	Electronic gear	Electronic gear ratio setting range: $0.01 \leq (G1/G2) \leq 100$ (G1, G2 = 1 to 65,535)				
	Positioning completed range	0 to 250 command units				
	Feed-forward compensation	0% to 100% of speed command amount (pulse frequency)				
	Bias setting	0 to 450 r/min				
	Position acceleration/deceleration time constant	0 to 64.0 ms (The same setting is used for acceleration and deceleration.)				
Input signals	Position command pulse input (see note)	TTL, line driver input with photoisolation, input current: 6 mA at 3 V Feed pulse and direction signal, forward pulse and reverse pulse, or 90° differential phase (A and B phases) signal (set via parameter). Pulse width: See note.				
	Deviation counter reset	TTL, line driver input with photoisolation, input current: 6 mA at 3 V				
	Sequence input	24-VDC, 5-mA photocoupler input, external power supply: 24±1 VDC, 50 mA min.				
Output signals	Position feedback output	A-, B-, Z-phase line driver output (EIA RS-422A) A-phase and B-phase (dividing rate setting): 16 to 2,048 pulses/revolution Z-phase: 1 pulse/revolution				
	Speed monitor output	0.5 V/1,000 r/min				
	Current monitor output	0.5 V/rated torque				
	Sequence output	Alarm output, motor rotation detection, brake interlock, positioning completion; open-collector outputs: 30 VDC, 50 mA (except for alarm code output, which is 30 VDC, 20 mA)				
External regeneration processing	Required for regeneration of more than 30 times the motor's rotor inertia.				Required for regeneration of more than 20 times the motor's rotor inertia.	
Protective functions	Overcurrent, grounding, overload, overvoltage, overspeeding, runaway prevention, transmission errors, encoder errors, deviation counter overflow					

Note The input pulse width must meet the following conditions.

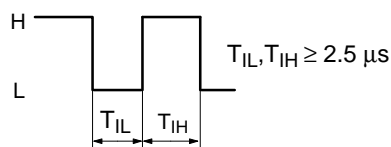

100-VAC Input Servo Drivers Conforming to UL/cUL and 100-VAC Input Servo Drivers Not Conforming to Any Standards

Item	R88D-UP03L(A)	R88D-UP04L(A)	R88D-UP10L(A)	R88D-UP12L(A)	R88D-UP15LA
Continuous output current (0-P)	0.9 A	1.3 A	3.1 A	3.8 A	4.8 A
Momentary max. output current (0-P)	2.8 A	4.1 A	10 A	12 A	15 A
Input power supply	Single-phase 100/115 VAC (85 to 127 V) 50/60 Hz				
Control method	All-digital servo				
Speed feedback	Optical encoder, 2,048 pulses/revolution				
Applicable load inertia	Maximum of 30 times motor's rotor inertia				20 times max.
Inverter method	PWM method based on IGBT				
PWM frequency	11 kHz				7.8 kHz
Applicable Servomotor	R88M-U03030L(A)	R88M-U05030L(A)	R88M-U10030L(A)	R88M-U20030L(A)	R88M-U30030LA
Applicable Servomotor wattage	30 W	50 W	100 W	200 W	300 W
Cable length between motor and driver	20 m max.				
Weight (approximate)	0.9 kg			1.2 kg	1.5 kg
Heating value	17 W	20 W	30 W	47 W	70 W
Capacity	Max. pulse frequency	200 kpps			
	Position loop gain	1 to 500 (1/s)			
	Electronic gear	Electronic gear ratio setting range: $0.01 \leq (G1/G2) \leq 100$ (G1, G2 = 1 to 65,535)			
	Positioning completed range	0 to 250 command units			
	Feed-forward compensation	0% to 100% of speed command amount (pulse frequency)			
	Bias setting	0 to 450 r/min			
	Position acceleration/deceleration time constant	0 to 64.0 ms (The same setting is used for acceleration and deceleration.)			
Input signals	Position command pulse input (see note)	TTL, line driver input with photoisolation, input current: 6 mA at 3 V Feed pulse and direction signal, forward pulse and reverse pulse, or 90 differential phase (A and B phases) signal (set via parameter). Pulse width: See note.			
	Deviation counter reset	TTL, line driver input with photoisolation, input current: 6 mA at 3 V			
	Sequence input	24-VDC, 5-mA photocoupler input, external power supply: 24±1 VDC, 50 mA min.			
Output signals	Position feedback output	A-, B-, Z-phase line driver output (EIA RS-422A) A-phase and B-phase (dividing rate setting): 16 to 2,048 pulses/revolution Z-phase: 1 pulse/revolution			
	Speed monitor output	0.5 V/1,000 r/min			
	Current monitor output	0.5 V/100%			
	Sequence output	Alarm output, motor rotation detection, brake interlock, positioning completion; open collector outputs: 30 VDC, 50 mA (except for alarm code output, which is 30 VDC, 20 mA)			

Item	R88D-UP03L(A)	R88D-UP04L(A)	R88D-UP10L(A)	R88D-UP12L(A)	R88D-UP15LA
External regeneration processing	Required for regeneration of more than 30 times the motor's rotor inertia.				Required for regeneration of more than 20 times the motor's rotor inertia.
Protective functions	Overcurrent, grounding, overload, overvoltage, overspeeding, runaway protection, transmission errors, encoder errors, deviation counter overflow				

Note The input pulse width must be meet the following conditions.

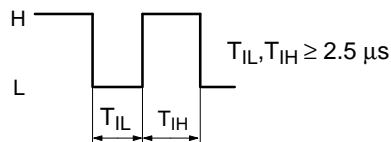

200-VAC Input Servo Drivers Conforming to EC Directives

Item	R88D-UP02V	R88D-UP03V	R88D-UP04V	R88D-UP08V	R88D-UP12V	R88D-UP20V
Continuous output current (0-P)	0.6 A	0.85 A	1.2 A	2.8 A	3.7 A	6.2 A
Momentary max. output current (0-P)	1.8 A	2.7 A	4.0 A	8.5 A	11.3 A	19.7 A
Input power supply	Single-phase 200/230 VAC (170 to 253 V) 50/60 Hz					
Control method	All-digital servo					
Speed feedback	Optical encoder, 2,048 pulses/revolution					
Applicable load inertia	Maximum of 30 times motor's rotor inertia				Maximum of 20 times motor's rotor inertia	
Inverter method	PWM method based on IGBT					
PWM frequency	11 kHz					7.8 kHz
Applicable Servomotor	R88M-U03030VA	R88M-U05030VA	R88M-U10030VA	R88M-U20030VA	R88M-U40030VA	R88M-U75030VA
Applicable Servomotor wattage	30 W	50 W	100 W	200 W	400 W	750 W
Cable length between motor and driver	20 m max.					
Weight (approximate)	0.9 kg				1.2 kg	1.5 kg
Heating value	15 W	18 W	20 W	35 W	45 W	60 W
Capacity	Maximum pulse frequency	200 kpps				
	Position loop gain	0 to 500 (1/s)				
	Electronic gear	Electronic gear ratio setting range: $0.01 \leq (G1/G2) \leq 100$ (G1, G2 = 1 to 65,535)				
	Positioning completed range	0 to 250 command units				
	Feed-forward compensation	0% to 100% of speed command amount (pulse frequency)				
	Bias setting	0 to 450 r/min				
	Position acceleration/deceleration time constant	0 to 64.0 ms (The same setting is used for acceleration and deceleration.)				
Input signals	Position command pulse input (see note)	TTL, line driver input with photoisolation, input current: 6 mA at 3 V Feed pulse and direction signal, forward pulse and reverse pulse, or 90 differential phase (A and B phases) signal (set via parameter). Pulse width: See note.				
	Deviation counter reset	TTL, line driver input with photoisolation, input current: 6 mA at 3 V				
	Sequence input	24-VDC, 5-mA photocoupler input, external power supply: 24±1 VDC, 50 mA min.				

Item		R88D-UP02V	R88D-UP03V	R88D-UP04V	R88D-UP08V	R88D-UP12V	R88D-UP20V
Output signals	Position feedback output	A-, B-, Z-phase line driver output (EIA RS-422A) A-phase and B-phase (dividing rate setting): 16 to 2,048 pulses/revolution Z-phase: 1 pulse/revolution					
	Speed monitor output	0.5 V/1,000 r/min					
	Current monitor output	0.5 V/rated torque					
	Sequence output	Alarm output, motor rotation detection, brake interlock, positioning completion; open-collector outputs: 30 VDC, 50 mA (except for alarm code output, which is 30 VDC, 20 mA)					
External regeneration processing		Required for regeneration of more than 30 times the motor's rotor inertia.				Required for regeneration of more than 20 times the motor's rotor inertia.	
Protective functions		Overcurrent, grounding, overload, overvoltage, overspeeding, runaway prevention, transmission errors, encoder errors, deviation counter overflow					

Note The input pulse width must meet the following conditions.

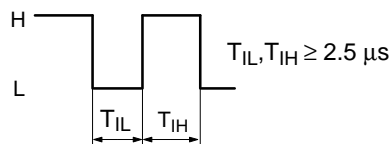

□ 100-VAC Input Servo Drivers Conforming to EC Directives

Item	R88D-UP03W	R88D-UP04W	R88D-UP10W	R88D-UP12W	R88D-UP15W
Continuous output current (0-P)	0.9 A	1.3 A	3.1 A	3.8 A	4.8 A
Momentary max. output current (0-P)	2.8 A	4.1 A	10 A	12 A	15 A
Input power supply	Single-phase 100/115 VAC (85 to 127 V) 50/60 Hz				
Control method	All-digital servo				
Speed feedback	Optical encoder, 2,048 pulses/revolution				
Applicable load inertia	Maximum of 30 times motor's rotor inertia				20 times max.
Inverter method	PWM method based on IGBT				
PWM frequency	11 kHz				7.8 kHz
Applicable Servomotor	R88M-U03030WA	R88M-U05030WA	R88M-U10030WA	R88M-U20030WA	R88M-U30030WA
Applicable Servomotor wattage	30 W	50 W	100 W	200 W	300 W
Cable length between motor and driver	20 m max.				
Weight (approximate)	0.9 kg			1.2 kg	1.5 kg
Heating value	17 W	20 W	30 W	47 W	70 W
Capacity	Max. pulse frequency	200 kpps			
	Position loop gain	1 to 500 (1/s)			
	Electronic gear	Electronic gear ratio setting range: $0.01 \leq (G1/G2) \leq 100$ ($G1, G2 = 1$ to 65,535)			
	Positioning completed range	0 to 250 command units			
	Feed-forward compensation	0% to 100% of speed command amount (pulse frequency)			
	Bias setting	0 to 450 r/min			
	Position acceleration/deceleration time constant	0 to 64.0 ms (The same setting is used for acceleration and deceleration.)			

Item		R88D-UP03W	R88D-UP04W	R88D-UP10W	R88D-UP12W	R88D-UP15W
Input signals	Position command pulse input (see note)	TTL, line driver input with photoisolation, input current: 6 mA at 3 V Feed pulse and direction signal, forward pulse and reverse pulse, or 90° differential phase (A and B phases) signal (set via parameter). Pulse width: See note.				
	Deviation counter reset	TTL, line driver input with photoisolation, input current: 6 mA at 3 V				
	Sequence input	24-VDC, 5-mA photocoupler input, external power supply: 24±1 VDC, 50 mA min.				
Output signals	Position feedback output	A-, B-, Z-phase line driver output (EIA RS-422A) A-phase and B-phase (dividing rate setting): 16 to 2,048 pulses/revolution Z-phase: 1 pulse/revolution				
	Speed monitor output	0.5 V/1,000 r/min				
	Current monitor output	0.5 V/100%				
	Sequence output	Alarm output, motor rotation detection, brake interlock, positioning completion; open collector outputs: 30 VDC, 50 mA (except for alarm code output, which is 30 VDC, 20 mA)				
External regeneration processing		Required for regeneration of more than 30 times the motor's rotor inertia.				Required for regeneration of more than 20 times the motor's rotor inertia.
Protective functions		Overcurrent, grounding, overload, overvoltage, overspeeding, runaway protection, transmission errors, encoder errors, deviation counter overflow				

Note The input pulse width must be meet the following conditions.

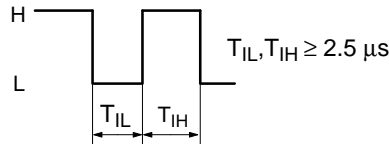

5-1-3 I/O Specifications

Terminal Block Specifications, Models Conforming to UL/cUL Standards and Models Not Conforming to Any Standards

Signal	Function	Condition	
R T	Power supply input	R88D-UP H(A) (200-VAC Units): Single-phase 200/230 VAC (170 to 253 VAC) 50/60 Hz R88D-UP L(A) (100-VAC Units): Single-phase 100/115 VAC (85 to 127 VAC) 50/60 Hz	
P N	Main circuit DC output	These are the connection terminals for the Regeneration Unit (R88A-RG08UA). Connect these when the regeneration energy is high.	
U	Servomotor U-phase output	Red	These are the terminals for outputs to the Servomotor.
V	Servomotor V-phase output	White	
W	Servomotor W-phase output	Blue	
⏏	Frame ground	Green	This is the connection terminal. Use a 100 Ω or less (class-3) or better ground. It is used in common for Servomotor output and power supply input.

Terminal Block Specifications, Models Conforming to EC Directives

Signal	Function	Condition	
L1 L2	Power supply input	R88D-UP V (200-VAC Units): Single-phase 200/230 VAC (170 to 253 VAC) 50/60 Hz R88D-UP W (100-VAC Units): Single-phase 100/115 VAC (85 to 127 VAC) 50/60 Hz	
+ -	Main circuit DC output	When using multiple axes and there is excessive regenerative energy, the + terminals can be connected together and the - terminals can be connected together to increase the regeneration absorption capacity.	
U	Servomotor U-phase output	Red	These are the terminals for outputs to the Servomotor.
V	Servomotor V-phase output	White	
W	Servomotor W-phase output	Blue	
	Protective earth terminal	Green	This is the connection terminal. Use a 100 Ω or less (class-3) or better ground.

□ **CN1: Control I/O Specifications (Common to Models Conforming to UL/cUL Standards, Models Not Conforming to Any Standards, and Models Conforming to EC Directives)**

CN1: Control Input

Pin No.	Signal name	Function	Contents
1	+PULS/CW/A	Feed pulse, reverse pulse, 90 differential phase pulse (A phase)	Line driver input: 6 mA at 3V Open collector input: 15 mA at -5V Switched between feed pulse and direction signal, reverse pulse and forward pulse, and 90 differential phase pulse (A and B phases) using bits 3, 4, and 5 of the Cn-02 setup parameter Maximum frequency: 200 kpps
2	-PULS/CW/A		
3	+SIGN/CCW/B	Direction signal, forward pulse, 90 differential phase pulse (B phase)	
4	-SIGN/CCW/B		
5	+ECRST	Deviation counter reset	Line driver input: 6 mA at 3V ON: Disables command input and resets deviation counter. Operation can be switched between a status signal (high level) and a differential signal (rising edge) using bit A in setup parameter Cn-02.
6	-ECRST		
11	PCL/SPD1	Forward rotation current limit input / Speed selection command 1 input	Forward/reverse rotation current limit (PCL/NCL) when setup parameter Cn-02 bit no. 2 = 0. (ON: Current limit)
12	NCL/SPD2	Reverse rotation current limit input / Speed selection command 2 input	Internal setting speed (Cn-1F, 20, 21) selector switch when setup parameter Cn-02 bit no. 2 = 1.
13	+24VIN	+24-V power supply input for control DC	Power supply for pin nos. 11, 12, 14, 15, 16, 17, 18; +24-V input
14	RUN	Run command input	ON: Servo ON, when setup parameter Cn-01 bit no. 0 = 0. When setup parameter Cn-01 bit no. 0 = 1, this signal is not used. (Automatically set to Servo ON.)
15	MING	Gain deceleration input	ON: Decrease speed loop gain, when setup parameter Cn-02 bit no. 2 = 0 and Cn-01 bit no. F = 0.
	IPG (HA/LA/V/W Models)	Pulse stop input	ON: Stop input command pulses, when setup parameter Cn-02 bit no. 2 = 0 and Cn-01 bit no. F = 1.
	RDIR	Rotation direction command inputs	When setup parameter Cn-02 bit no. 2 = 1, this is the rotation direction command for internal speed settings 1 to 3. (OFF: Forward, ON: Reverse)
16	POT	Forward drive prohibit input	Forward rotation overtravel input (OFF when prohibited). When setup parameter Cn-01 bit no. 2 = 1, this signal is not used.
17	NOT	Reverse drive prohibit input	Reverse rotation overtravel input (OFF when prohibited). When setup parameter Cn-01 bit no. 3 = 1, this signal is not used.
18	RESET	Alarm reset input	ON: Servo alarm status is reset.
28	---	---	Do not connect.
29	---	---	

CN1: Control Output

Pin No.	Signal name	Function	Contents
7	BKIR	Brake interlock output	Outputs external brake interlock signal.
8	INP	Positioning competed output	Turned ON when the pulse count remaining in the deviation counter is equal to or less than the positioning completed range set in user parameter Cn-1b.
9	TGON	Servomotor rotation detection output	When setup parameter Cn-01 bit no. 4 = 0, this turns ON if the Servomotor rotational speed exceeds the value set for the Servomotor rotation detection speed (Cn-0b).
	CLIMT	Current limit detection output	When setup parameter Cn-01 bit no. 4 = 1, this turns ON if the forward/reverse rotation current limit (PCL/NCL) is ON and the output torque reaches either the external current limit (Cn-18, 19) or the level of the lowest value set for the torque limit (Cn-08, -09). If the forward/reverse rotation current limit (PCL/NCL) is OFF, this output turns ON when the output torque reaches the value set for the torque limit (Cn-08, -09).
10	OGND	Output ground common	Output ground common for BKIR, VCMP, INP, TGON/CLIMT
19	EGND	Encoder signal output GND	This is the ground for encoder signal outputs.
20	+A	Encoder A-phase + output	Outputs encoder pulses divided according to user parameter Cn-0A. Line driver output (conforming to RS-422A).
21	-A	Encoder A-phase - output	
22	-B	Encoder B-phase - output	Outputs encoder pulses divided according to user parameter Cn-0A. Line driver output (conforming to RS-422A).
23	+B	Encoder B-phase + output	
24	+Z	Encoder Z-phase + output	Encoder Z-phase output (1 pulse/revolution). Line driver output (conforming to RS-422A).
25	-Z	Encoder Z-phase - output	
26	---	---	Do not connect.
27	---	---	
30	ALO1	Alarm code output 1	When an alarm is generated for the Servo Driver, the contents of the alarm are output in code. Open collector output: 30 VDC, 20 mA max.
31	ALO2	Alarm code output 2	
32	ALO3	Alarm code output 3	
33	ALOCOM	Alarm code output GND	
34	ALM	Alarm output	When an alarm is generated for the Servo Driver, the output is OFF. Open collector output.
35	ALMCOM	Alarm output GND	
36	FG	Frame ground (see note)	Ground terminal for shield wire of cable and FG line.

Note Pin 36 is not used on models conforming to the EC Directives.

Connectors Used (36P)

Sumitomo 3M	Receptacle at Servo Driver	10236-52A2JL
	Soldered plug at cable side	10136-3000VE
	Case at cable side	10336-52A0-008

Pin Arrangement

2	-PULS /CW/A	-feed pulse, reverse pulse, A phase	1	+PULS /CW/A	+feed pulse, reverse pulse, A phase	20	+A	Encoder A-phase + output	19	EGND	Encoder signal output GND
4	-SIGN/ CCW/B	-direction signal, forward pulse, B phase	3	+SIGN/ CCW/B	+direction signal, forward pulse, B phase	22	-B	Encoder B-phase - output	21	-A	Encoder A-phase - output
6	-ECRST	-deviation counter reset	5	+ECRST	+deviation counter reset	24	+Z	Encoder Z-phase + output	23	+B	Encoder B-phase + output
8	INP	Positioning completed output	7	BKIR	Brake interlock output	26			25	-Z	Encoder Z-phase - output
10	OGND	Output ground common	9	TGON/ CLIMT	Motor rotation detection, current control detection	28			27		
12	NCL/ SPD2	Reverse rotation current limit, speed selection command 2	11	PCL/ SPD1	Forward rotation current limit, speed selection command 1	30	ALO1	Alarm code output 1	29		
14	RUN	Run command input	13	+24VIN	Control DC +24-V input	32	ALO3	Alarm code output 3	31	ALO2	Alarm code output 2
16	POT	Forward rotation drive prohibit input	15	MING/ IPG/ RDIR	Gain deceleration, pulse stop input, rotation direction	34	ALM	Alarm output	33	ALOCOM	Alarm code output GND
18	RESET	Alarm reset input	17	NOT	Reverse rotation drive prohibit input	36	FG (see note 2)	Frame ground	35	ALMCOM	Alarm output GND

Note 1. The IPG (pulse stop input) setting for pin number 15 can be selected in HA/LA/V/W Models only.

Note 2. Pin 36 is not used on models conforming to EC Directives.

□ Control Input Interface

The input circuit for the control I/O connector (CN1) is as shown in the following diagram.

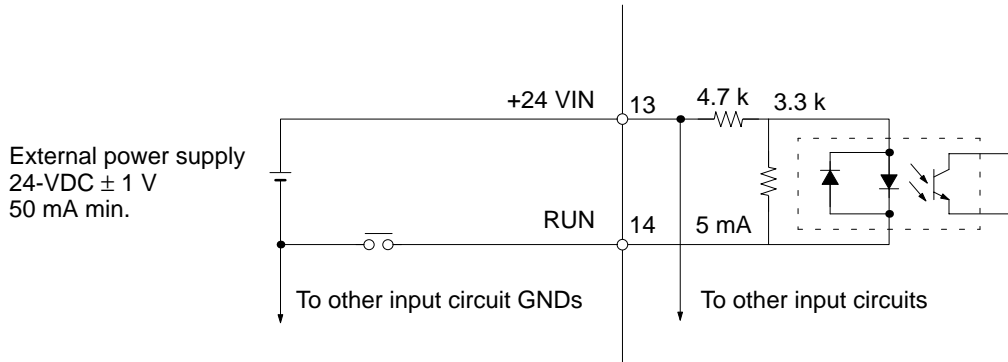

Run Command (14: RUN)

This is the input that turns on the power drive circuit for the main circuit of the Servo Driver. If this signal is not input (i.e., servo-off status), the Servomotor cannot operate. Depending on the setting of setup parameter Cn-01, bit no. 0, this signal can be bypassed. In that case, the servo will be turned on after the power is turned on.

Gain Reduction (15: MING), Pulse Stop (15: IPG), Rotation Direction Command (15: RDIR)

This input signal can be switched among the following three kinds of signals by changing on the settings of bit 2 of setup parameter Cn-02 and bit F of setup parameter Cn-01. Select the signal function required for your application.

• **Gain Reduction (15: MING; Cn-02 Bit No. 2 = 0 and Cn-01 Bit No. F = 0)**

Bit F of Cn-01 can be set in HA/LA/V/W Models only. Input this signal to lower the loop gain for the control loop, and to weaken servo rigidity (repellant force with respect to external force).

When the gain reduction is input, speed loop integration is disabled, decreasing the speed loop gain.

In addition, when parts are inserted after positioning, the insertion operation is made easier because the repellant force with respect to external force is weakened by the inputting of this signal. This cannot be used for the vertical shaft where a gravity load is applied, because position deviation will occur.

• **Pulse Stop (15: IPG; Cn-02 Bit No. 2 = 0 and Cn-01 Bit No. F = 1)**

This signal can be used in HA/LA/V/W Models only. Command signals won't be received internally while this signal is ON.

• **Rotation Direction Command (15: RDIR; Cn-02, Bit No. 2= 1)**

This signal becomes the rotation direction change command for when operation is carried out at the internally set speed (no. 1 through no. 3 internally set speeds). When this signal is not input, the rotation direction is forward; when it is input, the direction is reverse.

Forward Drive Prohibit (16: POT, Cn-01 bit No. 2 = 0)

Reverse Drive Prohibit (17: NOT, Cn-01 bit No. 3 = 0)

These two signals are the inputs for forward and reverse drive prohibit (overtravel). When they are input, driving is possible in the respective directions. When driving is prohibited, movement will stop ac-

According to the settings of bits nos. 6, 8, and 9 of setup parameter no. 1 (Cn-01). Alarm status will not be generated at the Driver. When drive prohibition is not used, clear the function by connecting the respective signal to the external power supply +24-V GND or setting setup parameter Cn-01, bit nos. 2, 3 = 1,1.

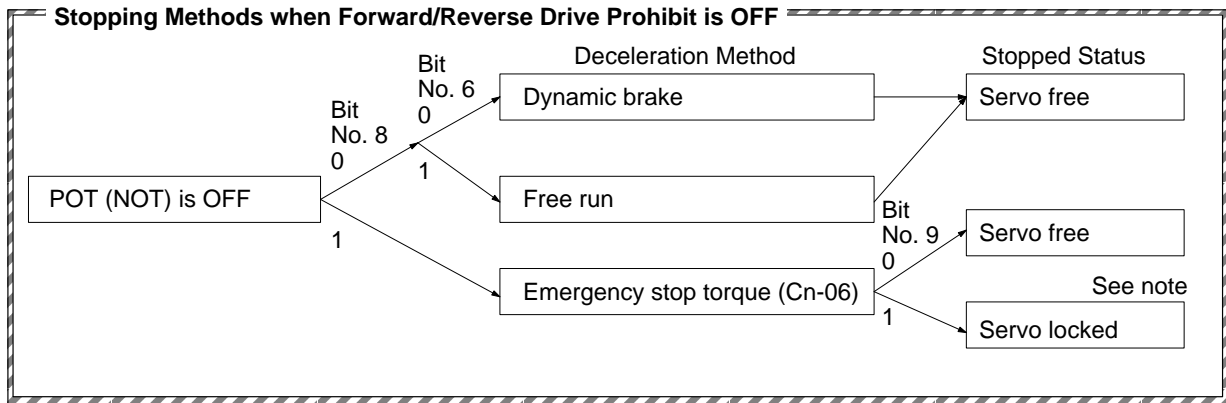

Note The position loop is not valid when stopping with this mode.

Forward/Reverse Rotation Current Limit [11, 12: (PCL/SPD1), (NCL/SPD2)]

These input signals switch between the forward/reverse current limit and the speed selection command signal for the internally set speed, depending on the setting of setup parameter Cn-02 bit no. 2. Set the required functions for using it.

• **Forward/Reverse Rotation Current Limit (11, 12: PCL, NCL)**

When setup parameter Cn-02 bit no. 2 = 0, these input signals become respectively the forward rotation current limit and the reverse rotation current limit, and they limit the current to the Servomotor. The current limit values can be set for the respective directions by means of user parameters Cn-18 and 19.

• **Speed Selection Command (11, 12: SPD1, SPD2)**

When setup parameter Cn-02 bit no. 2 = 1, these input signals become the speed selection command 1 and the speed selection command 2. Depending on the combination, the Servomotor speed can be controlled according to the internally set speeds, nos. 1 through 3, which are set in user parameter Cn-1F, 20, 21. At that time, the CN1-15 pin becomes the rotation direction command (RDIR).

Alarm Reset (18: RESET)

This is the external reset signal input for the servo alarm. The alarm is reset when the signal turns ON. Remove the cause of the alarm and then restart operation. In order to prevent danger, turn OFF the run command before inputting the reset signal.

Command Pulse Inputs and Deviation Counter Reset Inputs

The input circuits for command pulse and deviation counter reset inputs are shown in the following diagram.

Line-driver Input

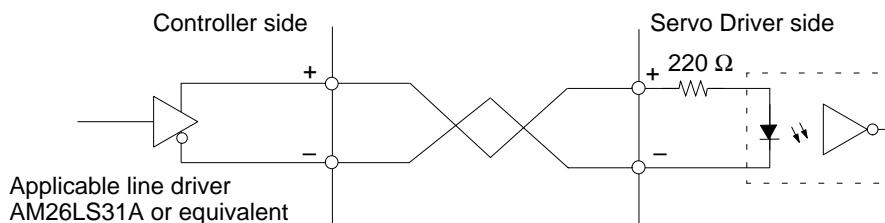

Open-collector Input

When connected with open collector output, insert a current limit resistor as shown below.

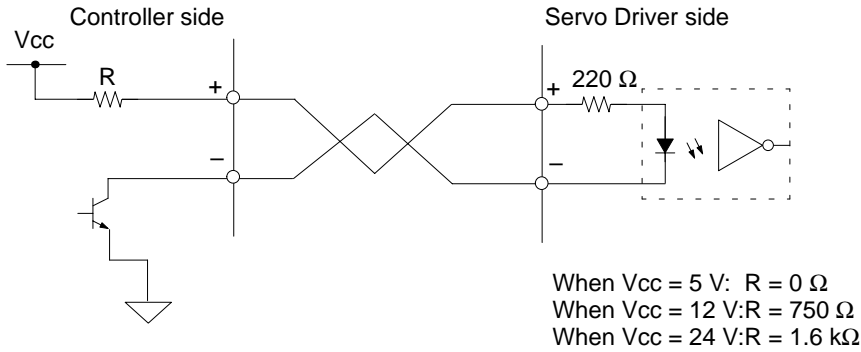

Deviation Counter Reset (5, 6: +ECRST/–ECRST)

The contents of the deviation counter will be reset and the position loop will be disabled when the deviation counter reset signal turns ON.

The deviation counter reset signal must be input for at least 20 μs to be effective. The counter may or may not be reset if the input signal is less than 20 μs .

The setting of Cn-02 bit No. A determines whether setting is performed on the high signal level or on the rising edge of the signal.

- **+Feed Pulse/Reverse Pulse/90° Differential Pulse A Phase (CN1-1: +PULS/+CW/+A)**
- **–Feed Pulse/Reverse Pulse/90° Differential Pulse A Phase (CN1-2: –PULS/–CW/–A)**
- **+Direction Signal/Forward Pulse/90° Differential Pulse B Phase (CN1-3: +SIGN/+CCW/+B)**
- **–Direction Signal/Forward Pulse/90° Differential Pulse B Phase (CN1-4: –SIGN/–CCW/–B)**

The functions of the above pulses depend on the command pulse mode and command pulse logic setting.

• **Command Pulse Mode (Cn-02 bit nos. 5, 4, 3)**

Cn-02 bit nos. 5, 4, 3 = 0, 0, 0	Feed pulses and direction signal
Cn-02 bit nos. 5, 4, 3 = 0, 0, 1	Forward pulse and reverse pulse (factory default)
Cn-02 bit nos. 5, 4, 3 = 0, 1, 0	90° differential phase (A and B phases) signal (1X)
Cn-02 bit nos. 5, 4, 3 = 0, 1, 1	90° differential phase (A and B phases) signal (2x)
Cn-02 bit nos. 5, 4, 3 = 1, 0, 0	90° differential phase (A and B phases) signal (4X)

• **Command Pulse Logic Reversal (Cn-02 bit no. d)**

Cn-02 bit no. d = 0	Positive logic
Cn-02 bit no. d = 1	Negative logic

Logic	Bits			Input factor	Command pulse mode	Input pins	Forward motor commands	Reverse motor commands
	5	4	3					
Positive	0	0	0	---	Forward pulse and direction signal	1: +PULS 2: -PULS 3: +SIGN 4: -SIGN		
	0	0	1	---	Reverse pulse and forward pulse	1: +CW 2: -CW 3: +CCW 4: -CCW		
	0	1	0	×1	90 differential phase signals	1: +A 2: -A 3: +B 4: -B		
	0	1	1	×2				
	1	0	0	×4				
Negative	0	0	0	---	Forward pulse and direction signal	1: +PULS 2: -PULS 3: +SIGN 4: -SIGN		
	0	0	1	---	Reverse pulse and forward pulse	1: +CW 2: -CW 3: +CCW 4: -CCW		
	0	1	0	×1	90 differential phase signals	1: +A 2: -A 3: +B 4: -B		
	0	1	1	×2				
	1	0	0	×4				

Command Pulse Timing

Command pulse mode	Timing
Forward pulse and direction signal Maximum frequency: 200 kpps	<p style="text-align: right;"> $t1 \leq 0.1\mu s$ $\tau \geq 2.5\mu s$ $t2 > 3.0\mu s$ $T \geq 5.0\mu s$ </p>
Reverse pulse and forward pulse Maximum frequency: 200 kpps	<p style="text-align: right;"> $t1 \leq 0.1\mu s$ $\tau \geq 2.5\mu s$ $t2 > 3.0\mu s$ $T \geq 5.0\mu s$ </p>
90 differential phase signals (A and B pulses) Maximum frequency: 200 kpps	<p style="text-align: right;"> $t1 \leq 0.1\mu s$ $\tau \geq 2.5\mu s$ $T \geq 5.0\mu s$ </p>

Note Although the above timing charts show positive logic, the same conditions hold for negative logic.

□ Control Output Interface

The output circuit for the control I/O connector (CN1) is as shown in the following diagram.

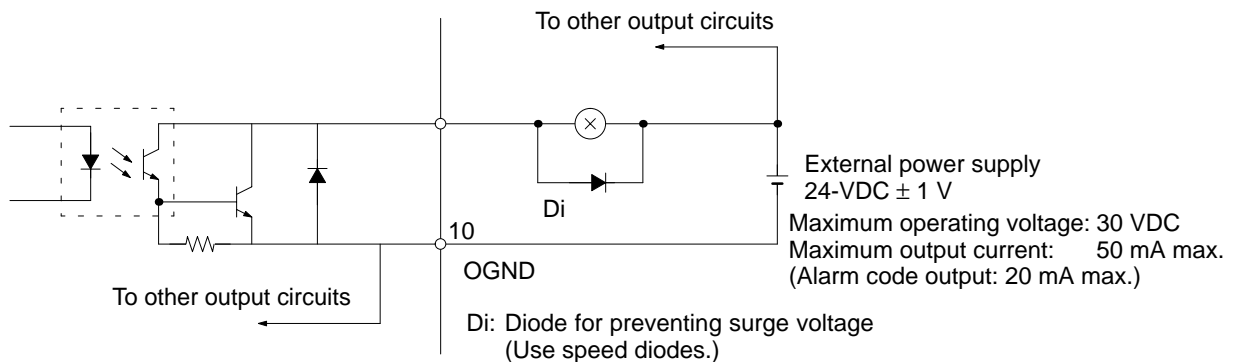

Control Output Sequence

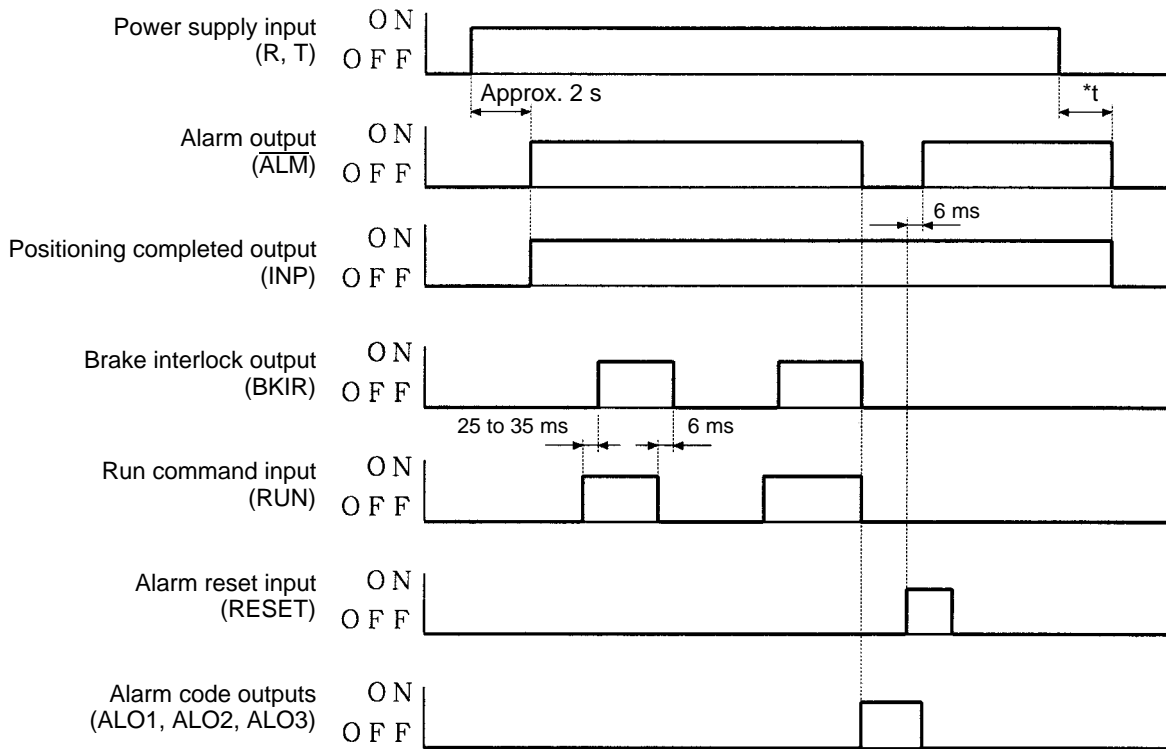

*t = Approx. 6 s: R88D-UP02H(A)/-UP03H(A)/-UP03L(A)
 R88D-UP02V/-UP03V/-UP03W
 Approx. 10 s: R88D-UP04H(A)/-UP08H(A)/-UP12H(A)
 R88D-UP04L(A)/-UP10L(A)/-UP12L(A)
 R88D-UP04V/-UP08V/-UP12V
 R88D-UP04W/-UP10W/-UP12W
 Approx. 15 s: R88D-UP20H(A)/-UP15L(A)
 R88D-UP20V/-UP15W

Brake Interlock (7: BKIR)

This outputs the external brake timing signal set in Cn-12, 15, and 16. Refer to 3-5-8 Brake Interlock (For Motors with Brakes) for details.

Positioning Completed Output (8: INP)

This output is turned ON when the pulse count remaining on the deviation counter is less than the positioning completed range set in user parameter Cn-1b. If the command speed is low and the positioning completed range is large, the positioning completed output will remain ON.

Motor Rotation Detection (9: TGON/CLIMIT)

This output switches between the Servomotor rotation detection output signal and the current limit detection signal depending on the setting of setup parameter Cn-01 bit no. 4.

• Motor Rotation Detection (9: TGON; Setup Parameter Cn-01 Bit No. 4 = 0)

Outputs when the motor rotational speed equals or exceeds the value set for user parameter Cn-0b (rotational speed for motor rotation detection).

• **Current Limit Detection (9: CLIMIT; Setup Parameter Cn-01 Bit No. 4 = 1)**

When the forward current limit (PCL) and the reverse current limit (NCL) are input, this signal is output when the Servomotor's output torque reaches the lower of the two following torque limit values: the torque limit value set for user parameters Cn-18, -19 (forward/reverse rotation external current limit) or the torque limit value set for user parameters Cn-08, -09 (forward/reverse rotation torque limit).

Alarm Output/Alarm Output Ground (34/35: $\overline{\text{ALM}}$ /ALMCOM)

When the Servo Driver detects an error, outputs are turned OFF. At that time, an alarm code (see below) is output according to the contents of the error. This output is OFF at the time of powering up, and turns ON when the power-up processing is completed.

Alarm Code Outputs 1 to 3 and Alarm Code Output Ground (30, 31, 32, 33: AL01 to AL03 and 33: ALOCOM)

When a Servo Driver error is generated, the contents of the error are output in 3-bit code. For details, refer to 4-3-1 Alarm Displays and Alarm Code Outputs.

Encoder A-, B-, and Z-phase Outputs (20, 21: +A, -A; 23, 22: +B, -B, 24, 25: +Z, -Z)

Servomotor encoder signals are output as divided phase-difference pulses according to the user parameter encoder divider rate setting (Cn-0A). The output form is line driver output, and conforms to EIA-RS-422A. Receive with a line receiver or high-speed photocoupler.

• **Output Phase (When Encoder Divider Rate Setting is 2,048)**

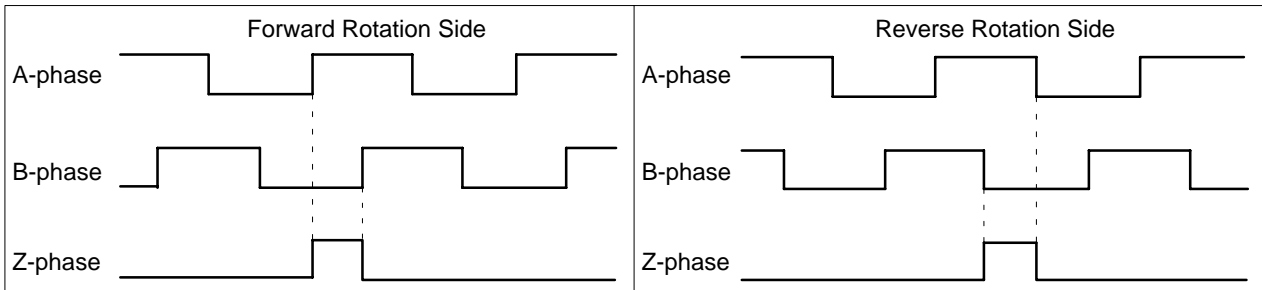

• Output Circuit and Receiving Circuit

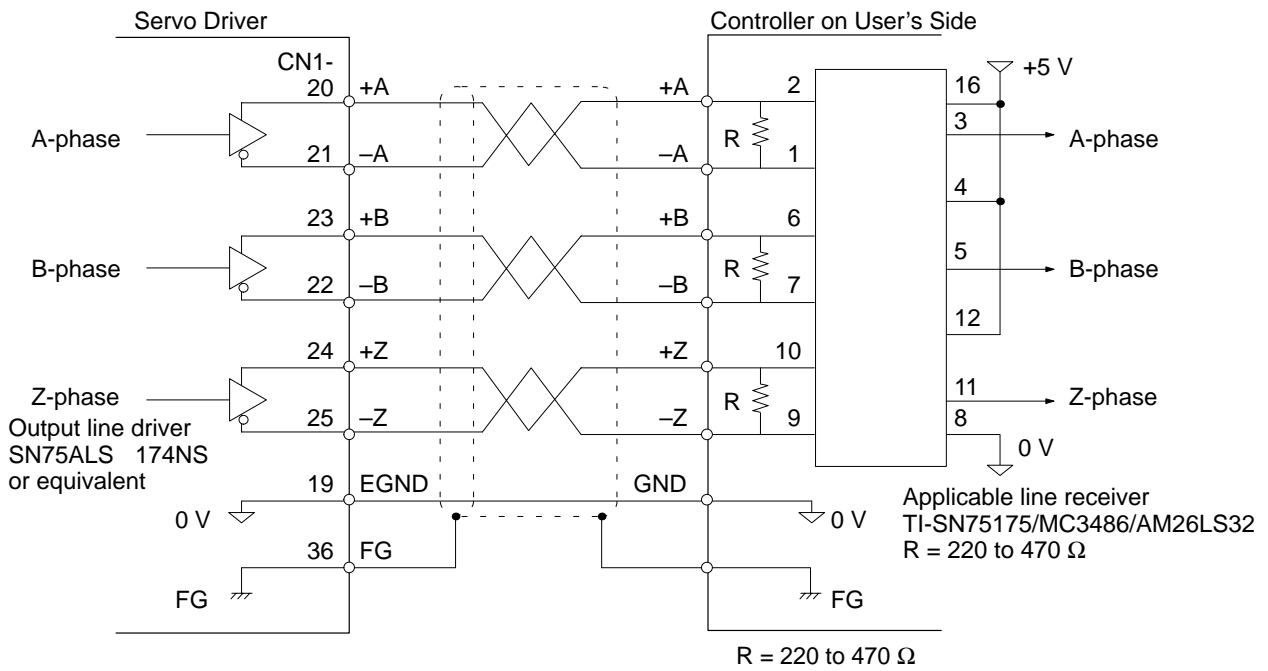

□ Control I/O Signal Connections and External Signal Processing

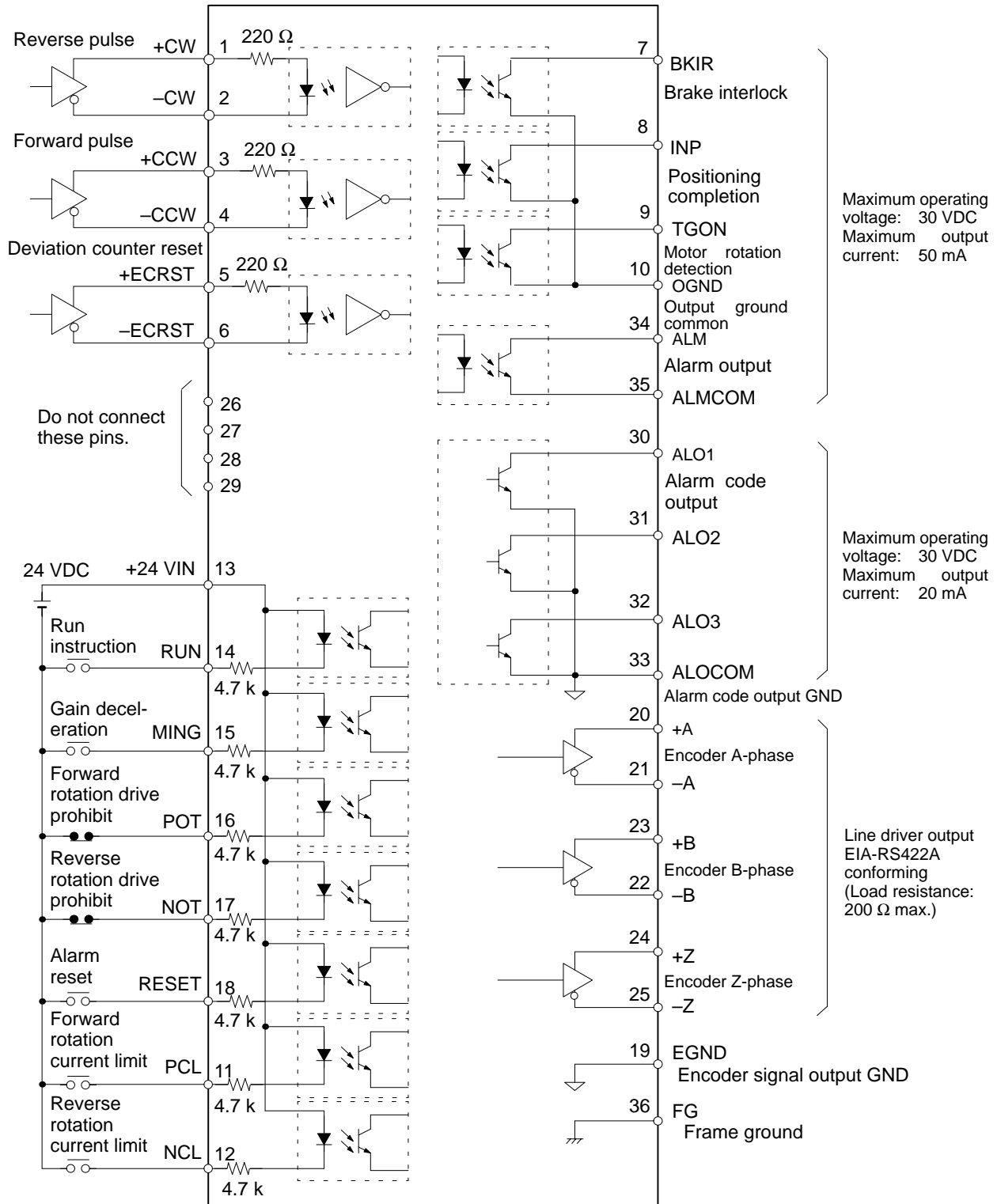

Note Pin 36 is not used with models conforming to EC Directives.

□ **CN2: Encoder Input Specifications**

Pin No.	Signal name	Function	Interface
1, 2, 3	E0V	Encoder power supply GND	Power supply outlet for encoder: 5 V, 120 mA
4, 5, 6	E5V	Encoder power supply +5 V	
7	DIR	Rotation direction switch input	Connects to E0V when reverse rotation is executed by + input.
8, 9	NC	Not used	Do not connect.
10, 11	NC	Not used	Do not connect.
12, 13	NC	Not used	Do not connect.
14	S+	Encoder + S-phase input	Line driver input (conforming to EIA-RS422A) (Input impedance: 220 Ω)
15	S-	Encoder – S-phase input	
16	A+	Encoder + A-phase input	Line driver input (conforming to EIA-RS422A) (Input impedance: 220 Ω)
17	A-	Encoder – A-phase input	
18	B+	Encoder + B-phase input	Line driver input (conforming to EIA-RS422A) (Input impedance: 220 Ω)
19	B-	Encoder – B-phase input	
20 (see note)	FG	Shielded ground	Cable shielded ground

Note Pin 20 is not used on models conforming to EC Directives. Instead, connect the cable shield to the connector plug and ground it directly using a clamp.

Connectors Used (20P)

Sumitomo 3M	Receptacle at Servo Driver	10220-52A2JL
	Soldered plug at cable side	10120-3000VE
	Case at cable side	10320-52A0-008

Pin Arrangement

2	E0V	Encoder power supply GND	1	E0V	Encoder power supply GND	11	NC	
4	E5V	Encoder power supply +5 V	3	E0V	Encoder power supply GND	12	NC	
6	E5V	Encoder power supply +5 V	5	E5V	Encoder power supply +5 V	14	S+	Encoder + S-phase input
8	NC		7	DIR	Rotation direction switch input	16	A+	Encoder + A-phase input
10	NC		9	NC		18	B+	Encoder + B-phase input
						20	FG (see note)	Frame ground
						15	S-	Encoder – S-phase input
						17	A-	Encoder – A-phase input
						19	B-	Encoder – B-phase input

Note Pin 20 is not used with models conforming to EC Directives

Rotation Direction Change (7: DIR)

To set up the mechanical configuration so that a + voltage input causes reverse rotation instead of forward rotation, this terminal can be connected to the E0V terminal for any of pins 1 through 3 (encoder power supply GND terminal). This function carries out the same operation by means of setting setup parameter Cn-02 bit no. 0 to “1.” Use this to prevent runaway when replacing the Servo Driver.

When the rotation direction is changed, the encoder A-phase and B-phase output phases are also changed. When not set, + voltage is for forward rotation and A-phase advance; when set, + voltage if for reverse rotation and A-phase advance (and - voltage is for forward rotation and B-phase advance). Therefore wiring changes are unnecessary for encoder signals to the position controller.

Encoder Pulse Input Signals (A-, B-, S-phase)

Inputs signals output from the Servomotor encoder. In S-phase, servo sensor U-, V-, W-, and Z-phase are transmitted according to A- and B-phase logic.

Encoder Power Supply Grounds (1 to 3: E0V) and Encoder Power Supply 5 V (E5V: 4 to 6)

Outputs +5.2 ±0.1 V as the power supply for the Servomotor encoder. The encoder power supply cannot be used for other purposes.

CN3: Parameter Unit Input Specifications

Pin No.	Signal name	Function	I/O interface
1	TXD+	Transmission data +	This is the send data line-driver output to the Parameter Unit (or a personal computer).
2	TXD-	Transmission data -	
3	RXD+	Reception data +	This is the send data line-driver input from the Parameter Unit (or a personal computer).
4	RXD-	Reception data -	
5	PRMU	Unit switching	This is the switching terminal for a Parameter Unit or personal computer. If the pin is open, it is for a personal computer. If connected to +5V, it is for a Parameter Unit.
6	RT1	Termination resistance enabled/disabled	This is the termination resistance terminal for the line receiver. For 1-to-1 communications or for the final Servo Driver, short-circuit RT1-RT2.
7	RT2		
8	+5V	+5 V output	This is the +5 V output to the Parameter Unit.
9	GND	Ground	

Pin Arrangement

1	TXD+	Transmission data +	6	RT1	Termination resistance on/off
2	TXD-	Transmission data -	7	RT2	
3	RXD+	Reception data +	8	+5V	+5-V output
4	RXD-	Reception data -	9	GND	Ground
5	PRMU	Unit switching			

Connectors Used (D-sub Connector, 9 Pin)

Dai-ichi Denshi Kogyo	Socket at Servo Driver	17LE-13090-27 (D2BC)
	Soldered plug at cable side	17JE-23090-02 (D1)
	Cover at cable side	17JE-09H-15
OMRON	Soldered plug at cable side	XM2A-0901
	Cover at cable side	XM2S-0912

CN4: Speed/Current Monitor Specifications

Pin	Signal name	Function	I/O interface
1	NM	Speed monitor output	Voltage output with a ratio of $\pm 0.5 \text{ V} / (1,000 \text{ r/min})$, centered at 0V. (-) voltage is forward, (+) voltage is reverse, and output accuracy is about $\pm 10\%$.
2	AM	Current monitor output	Voltage output with a ratio of $\pm 0.5 \text{ V} / (\text{rated torque})$, centered at 0V. (-) voltage is forward acceleration, (+) voltage is reverse acceleration. Output accuracy is about $\pm 10\%$.
3, 4	GND	Output ground	This is the output ground mentioned above.

Connectors Used (4 Pin)

Hirose Electric	Pin header at Servo Driver	DF11-4DP-2DS
	Socket at cable side	DF11-4DS-2C
	Socket crimp-type terminal at cable side	DF11-2428 SC

5-1-4 Explanation of User Parameters

Refer to 3-4-2 *Setup Parameter Contents* and 3-5-2 *User Parameter Chart* for a table of user parameters and setup parameters.

Speed Loop Gain: Cn-04

This is the proportional gain for the speed controller. The adjustable range is 1 to 2,000 Hz (the response frequency when equivalent inertia is used). As the number is increased, the gain is increased.

The factory setting is for 80 (Hz). Using the factory setting for the Servomotor alone or with a small load inertia will cause vibration to occur, so set the value to a maximum of 20 (Hz) for operation.

Speed Loop Integration Constant: Cn-05

This is the integration time for the speed controller. The adjustable range is 2 to 10,000 (ms), and it is factory set to 20 (ms). As the number is increased, the gain is decreased. The unit can be changed using the integration time constant setting unit (Cn-02 bit No-b). (HA/LA/V/W Models)

Emergency Stop Torque: Cn-06

When setup parameter Cn-01 bit no. 8 = 1, this sets the braking torque for over-travel stopping (forward/reverse drive prohibit input operation). The setting range is 0 to the maximum torque (a percentage of the braking torque as 100% of the Servomotor rated torque). The factory setting is for the maximum torque.

Software Start Acceleration Time: Cn-07

Software Start Deceleration Time: Cn-23

The Servomotor rotation acceleration time from 0 r/min to 4,500 r/min is set in Cn-07, and the deceleration time from 4,500 r/min to 0 r/min is set in Cn-23. The factory setting is for 0 (ms). Set the acceleration and deceleration times to 0 (ms) unless using the internal speed settings.

Forward Torque Control: Cn-08**Reverse Torque Control: Cn-09**

The Servomotor output torque control value for forward rotation is set in Cn-08, and the value for reverse rotation is set in Cn-09. The setting range is 0 to the maximum torque, and the factory setting is for the maximum torque.

Encoder Divider Rate: Cn-0A

The number of pulses detected (A- and B-pulses) per encoder revolution is converted to the number of pulses set for this parameter and output from the Servo Driver. The setting range is 16 to 2,048 pulses/revolution, and the factory setting is for 1,000 (pulses/revolution).

Rotational Speed for Servomotor Rotation Detection: Cn-0b

This sets the rotational speed for detecting whether or not the Servomotor is rotating. The setting range is 1 to 4,500 r/min. When motor rotation detection has been set for the sequence output signal switch (Cn-01 bit 4 = 0), the Servomotor rotation detection output (TGON: CN1-9) is turned ON if the Servomotor rotational speed meets or exceeds this set value. The factory setting is for 20 (r/min).

P Control Switching (Torque Command): Cn-0C**P Control Switching (Speed Command): Cn-0d****P Control Switching (Acceleration Command): Cn-0E****P Control Switching (Deviation Pulse): Cn-0F**

These set the various points for switching the speed controller from PI control to P control in order to moderate excessive characteristics when an operation such as acceleration or deceleration is executed accompanied by output saturation of the controller. These selections are made by setting the setup parameter Cn-01 bit nos. b, d and C.

Jog Speed: Cn-10

This sets the speed for manual operation. The setting range is 0 to 4,500 r/min. During manual operation, operating commands are given from the Parameter Unit. The factory setting is for 500 (r/min).

Number of Encoder Pulses: Cn-11

This sets the number of pulses per revolution of a connected encoder. Do not change this parameter's setting; the Servomotor might not operate correctly if it is changed. The factory setting is for 2,048 (pulses/revolution).

Brake Timing 1: Cn-12**Brake Command Speed: Cn-15****Brake Timing 2: Cn-16**

These parameters determine the output timing of the brake interlock signal (BKIR), which controls the electromagnetic brake.

Brake timing 1 sets the delay time from the time of brake interlock goes OFF until the servo turns off. The setting range is 0 to 50 ($\times 10$ ms), and the factory setting is for 0 ($\times 10$ ms).

The brake command speed is the speed (r/m) used to turn OFF the brake interlock. The setting range is 0 to 4,500 (r/m) and the factory setting is for 100 (r/m).

Brake timing 2 sets the wait time from when the servo goes OFF until the brake interlock goes OFF. The setting range is 10 to 100 ($\times 10$ ms), and the factory setting is for 50 ($\times 10$ ms).

If the run command turns off, a servo error occurs, or the main-circuit power supply turns off during operation of a Servomotor with a brake, the dynamic brake comes on (setup parameter Cn-01 bit no. 6 = 0) and Servomotor rotation speed is decreased. When the speed drops to the level of the value set for the brake command speed (Cn-15), the brake interlock output (BKIR: CN1-7) turns OFF.

Even if the speed does not drop to the level of the value set for the brake command speed (Cn-15), the brake interlock output (BKIR: CN1-7) turns OFF after the time set for brake timing 2 has elapsed. (This time setting is made for the purpose of preventing damage to machinery or the Servomotor holding brake.)

Torque Command Filter Time Constant: Cn-17

This sets the low-pass filter time constant for the torque command. The setting range is 0 to 250 ($\times 100 \mu\text{s}$), and the factory setting is 4 ($\times 100 \mu\text{s}$).

The relationship between the filter time constant and the cut-off frequency can be found by means of the following formula:

$$f_c \text{ (Hz)} = 1 / (2\pi T) \quad : T = \text{Filter time constant}$$

If $T = 400 \text{ } (\mu\text{s})$, f_c will be approximately 400 (Hz).

When the characteristic vibration of the machinery is within the response frequency of the servo loop, Servomotor vibration will occur. In order to prevent this sympathetic vibration based on the characteristic vibration of the machinery, set the torque filter time constant to a value that will eliminate the vibration (i.e., set it to a high value).

Forward Rotation External Current Limit: Cn-18

Reverse Rotation External Current Limit: Cn-19

These set the Servomotor output torque limits for the forward and reverse directions. They are valid when the forward/reverse current limits (PCL/NCL CN1-11/12) are input. This function can't be used if the input command mode is set to "internal speed control settings." The setting range is 0 to the maximum torque, and the factory setting is for the 100 (%).

Position Loop Gain: Cn-1A

Adjust the position loop gain to the rigidity of the machine. Set to between 50 and 70 (1/s) for general NC machine tools, to between 30 and 50 (1/s) for general and assembly machines, and to 10 to 30 (1/s) for industrial robots.

Load alarms will be caused by machine oscillation if the position loop gain is increased for systems with low rigidity or systems with intrinsically low-frequency vibration.

The setting range is 1 to 500 (1/s), and the factory setting is 40 (1/s).

Positioning Completed Range: Cn-1b

This sets the deviation counter value for outputting the positioning completed output (INP). When the deviation counter value falls below this setting, the positioning completed output turns ON. The setting range is 0 to 250 (command units), and the factory setting is 3 (command units).

Bias Rotational Speed: Cn-1C

This is the setting for position control bias. Use this setting according to the load conditions in order to shorten positioning time. The setting range is 1 to 450 (r/min), and the factory setting is 0 (r/min).

Feed-forward Amount: Cn-1d

This is the feed forward compensation for the position controller. Positioning time is shortened by adding the command pulse differential to the speed command. The setting range is 0 to 100%, and the factory setting is 0%.

Deviation Counter Overflow Level: Cn-1E

This sets the level for detection deviation counter overflow. If the deviation counter value exceeds this set value, a servo alarm will be generated. The setting range is 1 to 32,767 ($\times 256$ command units), and the factory setting is 1,024 ($\times 256$ command units).

No. 1 Internal Speed Setting: Cn-1F (Factory Setting: 100 r/min)

No. 2 Internal Speed Setting: Cn-20 (Factory Setting: 200 r/min)

No. 3 Internal Speed Setting: Cn-21 (Factory Setting: 300 r/min)

Make these settings to control speeds by means of internal settings. The setting range is 0 to 4,500 (r/min). For details, refer to *3-5-3 Setting Internal Speed Control*.

Electronic Gear Ratio G1 (Numerator): Cn-24

Electronic Gear Ratio G2 (Denominator): Cn-25

The motor will be operated by the pulses resulting from the number of command pulses multiplied by the gear ratio (G1/G2).

The setting range for both G1 and G2 is 65,535, and the settings are restricted as follows:
 $(1/100) \leq (G1/G2) \leq 100$.

The factory setting is : G1 =4, G2 = 1 (i.e., an electronic gear ratio of 4/1). At the factory setting, inputting 2,048 pulses will cause one Servomotor revolution.

Position Command Acceleration/Deceleration Time Constant: Cn-26

This executes smoothing processing on command pulses for Servomotor operation. It is valid in the following cases:

- There is no acceleration or deceleration for command pulses.
- The command pulse frequency changes suddenly.
- The electronic gear ratio setting is large ($G1/G2 \geq 10$).

The setting range is 0 to 640 ($\times 0.1$ ms), and the factory setting is 0 ($\times 0.1$ ms).

Feed Forward Command Filter: Cn-27

This is the setting for the low-pass filter so that the feed forward amount is not added suddenly. Using this setting can prevent overshooting in the event of sudden changes in command pulse frequency. The setting range is 0 to 640 ($\times 0.1$ ms), and the factory setting is 0 ($\times 0.1$ ms).

Compensating Gain: Cn-28 (HA/LA/V/W Models)

When outputting a large torque (during acceleration, deceleration, etc.), the speed loop gain is decreased based on this setting. Motor vibration can be reduced by increasing this setting; also, the positioning time can be reduced because the speed loop gain can be set to a higher value.

If this setting is too high, follow-up delays can occur during acceleration and deceleration. The setting range is 0 to 100, and the factory setting is 0.

Adjust the compensation gain after adjusting the speed loop gain with Cn-04 and the speed loop integral time constant with Cn-05.

The compensation gain may not be 100 due to the speed loop gain and speed loop integral time constant set with Cn-04 and Cn-05, in which case increasing the compensation gain will cause an error.

Make sure that the set value is 0 before performing auto-tuning. Proper gain adjustment may not be possible with auto-tuning if the set value is not 0.

Unit Number Setting: Cn-29 (HA/LA/V/W Models)

This setting specifies the Servo Driver's unit number when communicating with a personal computer. Set the unit number to 0 when communicating with a single axis. Set the unit number from 1 to 14 when communicating with multiple axes; in this case, be sure not to use the same unit number for more than one Unit. The Servo Driver or personal computer might be damaged if the same unit number is used for more than one Unit. The setting range is from 0 to 14, and the factory setting is 0.

Refer to the *Computer Monitor Software Instruction Manual (I513)* for OMNUC U-series Servo Drivers for more details on the unit number setting.

5-2 Servomotor Specifications

5-2-1 General Specifications

Item	Specifications
Operating ambient temperature	0°C to 40°C
Operating ambient humidity	20% to 80% RH (with no condensation)
Storage ambient temperature	-10°C to 75°C
Storage ambient humidity	20% to 85% RH (with no condensation)
Storage and operating atmosphere	No corrosive gasses.
Vibration resistance	10 to 150 Hz in X, Y, and Z directions with 0.2-mm double amplitude; acceleration: 24.5 m/s ² max.; time coefficient: 8 min; 4 sweeps
Impact resistance	Acceleration 98 m/s ² max., in X, Y, and Z directions, three times
Insulation resistance	Between power line terminals and case: 10 MΩ min. (500 VDC megger)
Dielectric strength	Between power line terminals and case: 1,500 VAC for 1 min (10 mA max.) at 50/60 Hz (JEC 2121)
Run position	All directions
Insulation grade	Type A (JIS C4004): Models conforming to UL Standards Type B (JIS C4004): All models other than those in Type A
Structure	Totally-enclosed self-cooling
Protective structure	Models Conforming to UL/cUL Standards and Models Not Conforming to Any Standards: IP-42 (JEM1030) Models Conforming to EC Directives: IP-44 (IEC34-5) (excluding shaft opening) (Cannot be used in environment with water-soluble cutting fluids.)
Vibration grade	V-15 (JEC2121)
Mounting method	Flange-mounting

Note 1. Vibration may be amplified due to sympathetic resonance of machinery, so use the Servomotor Driver under conditions which will not exceed 19.6 m/s² over a long period of time.

Note 2. The above items reflect individual evaluation testing. The results may differ under compounded conditions.

Note 3. The Servomotor cannot be used in a misty atmosphere.

Note 4. The drip-proofing specifications for models conforming to UL/cUL Standards and models not conforming to any standards are special specifications covered by IP-44. (Models with drip-proof specifications provide drip-proofing on Servomotors with oil seals.)

5-2-2 Performance Specifications

200 VAC Servomotors

Item	Unit	R88M -U03030H(A) -U03030VA	R88M -U05030H(A) -U05030VA	R88M -U10030H(A) -U10030VA	R88M -U20030H(A) -U20030VA	R88M -U40030H(A) -U40030VA	R88M -U75030H(A) -U75030VA
Rated output (see note)	W	30	50	100	200	400	750
Rated torque (see note)	N m	0.095	0.159	0.318	0.637	1.27	2.39
Rated rotational speed	r/min	3,000	3,000	3,000	3,000	3,000	3,000
Momentary maximum rotational speed	r/min	4,500	4,500	4,500	4,500	4,500	4,500
Momentary maximum torque (see note)	N m	0.29	0.48	0.96	1.91	3.82	7.10
Momentary maximum/rated current ratio	%	310	317	322	300	308	316
Rated current (see note)	A (rms)	0.42	0.60	0.87	2.0	2.6	4.4
Momentary maximum current (see note)	A (rms)	1.3	1.9	2.8	6.0	8.0	13.9
Rotor inertia (GD ² /4)	kg m ²	0.21 × 10 ⁻⁵	0.26 × 10 ⁻⁵	0.40 × 10 ⁻⁵	1.23 × 10 ⁻⁵	1.91 × 10 ⁻⁵	6.71 × 10 ⁻⁵
Torque constant (see note)	N m/A	0.255	0.286	0.408	0.355	0.533	0.590
Induced voltage constant (see note)	mV/(r/min)	8.89	9.98	14.0	12.4	18.6	20.6
Power rate (see note)	kW/s	4.36	9.63	25.4	32.8	84.6	85.1
Mechanical time constant	ms	1.5	0.9	0.5	0.4	0.3	0.3
Winding resistance	Ω	15.8	9.64	6.99	1.34	1.23	0.45
Winding impedance	mH	23.1	16.9	13.2	7.2	7.9	5.7
Electrical time constant	ms	1.5	1.8	1.9	5.4	6.4	13
Weight	kg	Approx. 0.3	Approx. 0.4	Approx. 0.5	Approx. 1.1	Approx. 1.7	Approx. 3.4
Corresponding Servo Driver		R88D-UP02H(A) -UP02V	R88D-UP03H(A) -UP03V	R88D-UP04H(A) -UP04V	R88D-UP08H(A) -UP08V	R88D-UP12H(A) -UP12V	R88D-UP20H(A) -UP20V

Note The values for torque and rotational speed characteristics, are the values at an armature winding temperature of 100°C, combined with the Servo Driver. Other values are at normal conditions (20°C, 65%). The maximum momentary torque is a reference value.

AC Servomotor Heat Radiation Conditions

When an AC Servomotor is continuously operated at the rated conditions, a heat radiation plate equivalent to an rectangular aluminum plate of $t6 \times 250$ mm is required at the Servomotor flange mounting area. (This is for horizontal mounting, with nothing around the Servomotor and no interference from heat convection currents.)

100 VAC Servomotors

Item	Unit	R88M -U03030L(A) -U03030WA	R88M -U05030L(A) -U05030WA	R88M -U10030L(A) -U10030WA	R88M -U20030L(A) -U20030WA	R88M -U30030LA -U30030WA
Rated output (see note)	W	30	50	100	200	300
Rated torque (see note)	N m	0.095	0.159	0.318	0.637	0.954
Rated rotational speed	r/min	3,000	3,000	3,000	3,000	3,000
Momentary maximum rotational speed	r/min	4,500	4,500	4,500	4,500	4,500
Momentary maximum torque (see note)	N m	0.29	0.48	0.96	1.91	3.72
Momentary maximum/rated current ratio	%	317	322	323	311	400
Rated current (see note)	A (rms)	0.63	0.9	2.2	2.7	3.7
Momentary maximum current (see note)	A (rms)	2.0	2.9	7.1	8.4	14.8
Rotor inertia	kg m ² (GD ² /4)	0.21×10^{-5}	0.26×10^{-5}	0.40×10^{-5}	1.23×10^{-5}	1.91×10^{-5}
Torque constant (see note)	N m/A	0.168	0.194	0.156	0.255	0.279
Induced voltage constant (see note)	mV/(r/min)	5.87	6.79	5.43	8.9	9.74
Power rate (see note)	kW/s	4.36	9.63	25.4	32.8	47.3
Mechanical time constant	ms	1.6	0.9	0.6	0.4	0.3
Winding resistance	Ω	7.22	4.34	1.22	0.706	0.435
Winding impedance	mH	9.7	6.9	2.0	4.0	2.3
Electrical time constant	ms	1.3	1.6	1.6	5.7	5.3
Weight	kg	Approx. 0.3	Approx. 0.4	Approx. 0.5	Approx. 1.1	Approx. 1.7
Corresponding Servo Driver		R88D- UP03L(A) -UP03W	R88D- UP04L(A) -UP04W	R88D- UP10L(A) -UP10W	R88D- UP12L(A) -UP12W	R88D- UP15LA -UP15W

Note The values for torque and rotational speed characteristics, are the values at an armature winding temperature of 100°C, combined with the Servo Driver. Other values are at normal conditions (20°C, 65%). The maximum momentary torque is a reference value.

AC Servomotor Heat Radiation Conditions

When an AC Servomotor is continuously operated at the rated conditions, a heat radiation plate equivalent to an rectangular aluminum plate of $t6 \times 250$ mm is required at the Servomotor flange mounting area. (This is for horizontal mounting, with nothing around the Servomotor and no interference from heat convection currents.)

□ Specifications for Servomotors with Magnetic Brakes

The magnetic brakes installed in Servomotors with brakes are status-holding brakes with non-magnetized operation. The magnetic brake is released when a magnetic current (24 VDC) is applied. The magnetic brake is not meant to be used for braking. Using it for braking will damage it. During Servomotor operation, be sure to release the magnetic brake by applying a magnetic voltage. The specifications for Servomotors with brakes are similar to those for Servomotors without brakes, so except for inertia and weight, the various constants are all the same.

Note: The inertia for magnetic brakes is the load inertia.

Specifications for AC Servomotors With Brakes (Specifications in Common for 100 and 200 VAC)

Item	Unit	R88M -U03030 -B	R88M -U05030 -B	R88M -U10030 -B	R88M -U20030 -B	R88M -U30030 -B	R88M -U40030 -B	R88M -U75030 -B
Rotor inertia	kg m ² (GD ² /4)	0.21 × 10 ⁻⁵	0.26 × 10 ⁻⁵	0.40 × 10 ⁻⁵	1.23 × 10 ⁻⁵	1.91 × 10 ⁻⁵	1.91 × 10 ⁻⁵	6.71 × 10 ⁻⁵
Brake inertia	kg m ² (GD ² /4)	0.09 × 10 ⁻⁵			0.58 × 10 ⁻⁵			1.40 × 10 ⁻⁵
Total inertia	kg m ² (GD ² /4)	0.30 × 10 ⁻⁵	0.35 × 10 ⁻⁵	0.49 × 10 ⁻⁵	1.81 × 10 ⁻⁵	2.49 × 10 ⁻⁵	2.49 × 10 ⁻⁵	8.11 × 10 ⁻⁵
Weight (approx.)	kg	0.6	0.7	0.8	1.6	2.2	2.2	4.3
Magnetized voltage	V	24 VDC ±10% (No polarity)						
Power consumption	W (at 20°C)	6		6	6.5		6	
Current consumption	A (at 20°C)	0.25		0.25	0.27		0.25	
Static friction torque	N m	0.2 min.		0.34 min.	1.5 min.		2.5 min.	
Absorption time (see note 1)	ms	(40 max.)		(60 max.)	(100 max.)		(200 max.)	
Release time (see note 1)	ms	(20 max.)		(30 max.)	(40 max.)		(50 max.)	
Backlash	---	(±1°)						
Rating	---	Continuous						
Insulation grade	---	Type F (brake only)						

Note 1. The operation time measurement is the measured value with a surge killer (CR50500, by Okaya Electric Industrial Co.) installed.

Note 2. The items in parentheses are reference values.

5-2-3 Torque and Rotational Speed Characteristics

□ Torque Characteristics (With 3-m Standard Cable and 200-VAC Input)

R88M-U03030H(A)
R88M-U03030VA

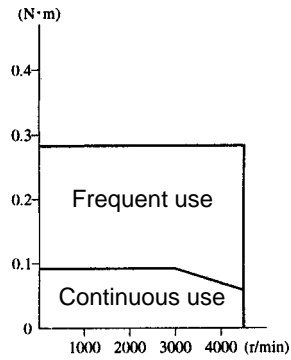

R88M-U05030H(A)
R88M-U05030VA

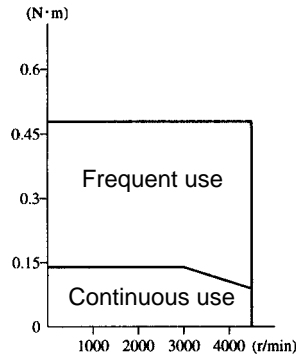

R88M-U10030H(A)
R88M-U10030VA

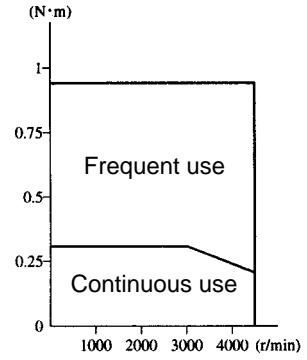

R88M-U20030H(A)
R88M-U20030VA

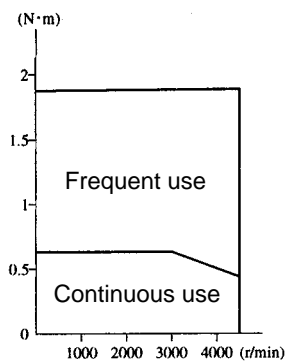

R88M-U40030H(A)
R88M-U40030VA

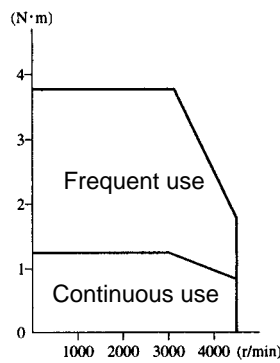

R88M-U75030H(A)
R88M-U75030

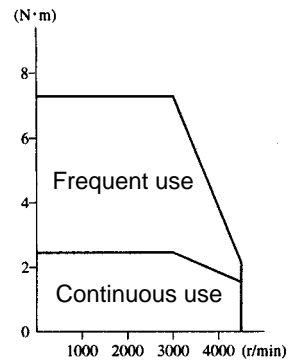

□ Torque Characteristics (With 3-m Standard Cable and 100-VAC Input)

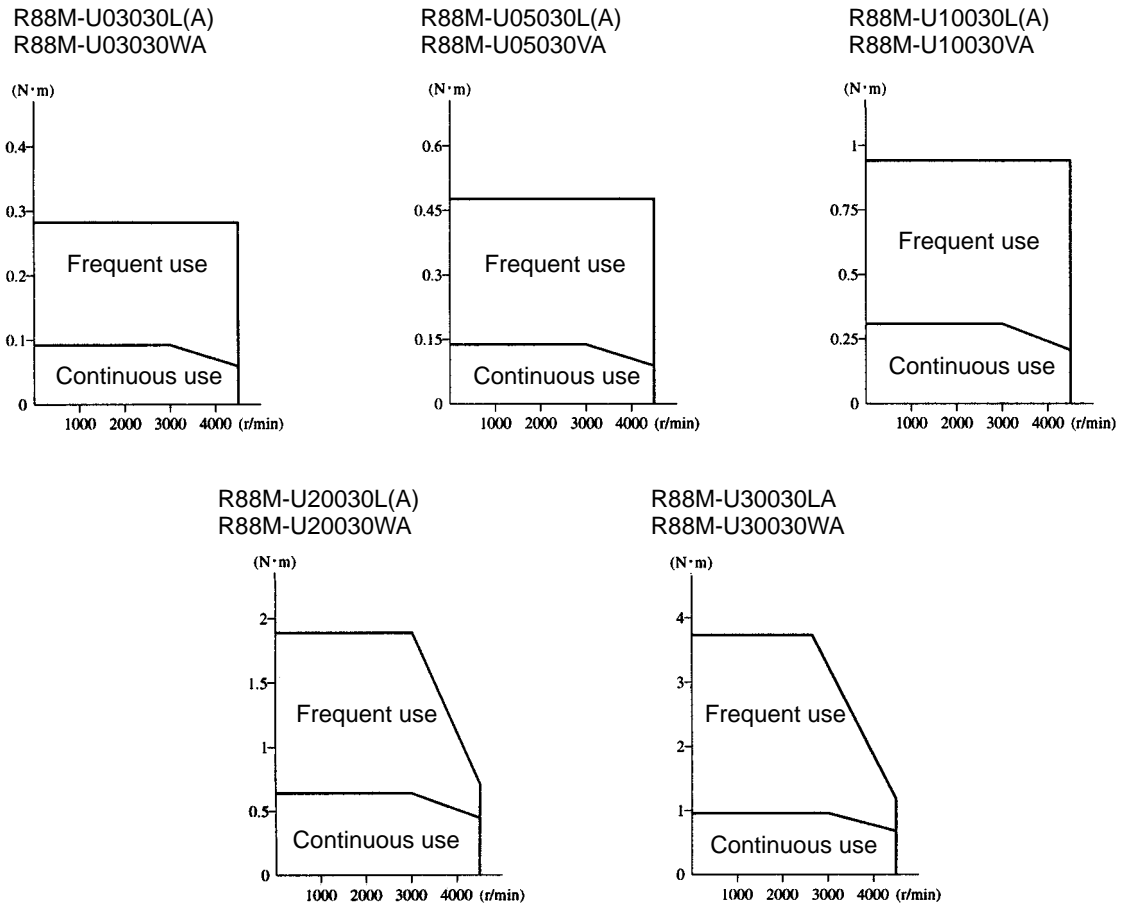

□ Servomotor and Mechanical System Temperature Characteristics

- U-series AC Servomotors use rare earth magnets (neodymium-iron magnets). The temperature coefficient for these magnets is approximately $-0.13\%/^{\circ}\text{C}$. As the temperature drops, the Servomotor's momentary maximum torque increases, and as the temperature rises the Servomotor's momentary maximum torque decreases. When the normal temperature of 20°C and -10°C are compared, the momentary maximum torque increases by approximately 4%. Conversely, when the magnet warms up to 80°C from the normal temperature of 20°C , the momentary maximum torque decreases by approximately 8%.
- Generally, in a mechanical system, when the temperature drops the friction torque increases and the load torque becomes larger. For that reason, overloading may occur at low temperatures. In particular, in systems which use deceleration devices, the load torque at low temperatures may be nearly twice the load torque at normal temperatures. Check with a current monitor to see whether overloading is occurring at low temperatures, and how much the load torque is. Likewise, check to see whether there abnormal Servomotor overheating or alarms are occurring at high temperatures.
- An increase in load friction torque increases the apparent load inertia. Therefore, even if the Servo Driver parameters are adjusted at a normal temperature, there may not be optimal operation at low temperatures. Check to see whether there is optimal operation at low temperatures too.

5-2-4 Allowable Loads on Servomotor Shafts

The allowable loads on Servomotor shafts are shown in the following table. Operate the Servomotor at no more than the allowable radial and thrust loads. At the time of assembly, assemble the Servomotor at no more than the momentary maximum radial and thrust loads (static pressure).

Servomotor	Momentary allowable radial load (static pressure)	Momentary allowable thrust load (static pressure)	Allowable radial load	Allowable thrust load
	N	N	N	N
R88M-U03030	186	127	68	54
R88M-U05030	186	127	68	54
R88M-U10030	186	127	78	54
R88M-U20030	490	176	245	74
R88M-U30030	490	176	245	74
R88M-U40030	490	176	245	74
R88M-U75030	735	392	392	147

Note 1. The allowable loads are the same for motors with brakes.

Note 2. The allowable radial load is the value at a point 5 mm from the end of the shaft.

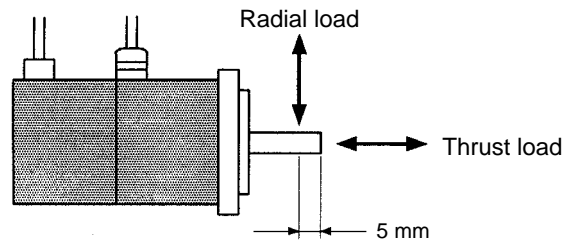

Note 3. The allowable radial and thrust loads are values determined with a service life of 20,000 hours taken as a criteria.

Note 4. The service life of bearing grease is 20,000 hours at a Servomotor ambient temperature of 40°C, and under the rated operating conditions.

Note 5. Absolutely do not impact the Servomotor or the output shaft by striking them with an implement such as a hammer. Doing so will damage the Servomotor and encoder bearings.

Note 6. Make sure that the radial load is within the allowable range when there is a radial load applied. If the Servomotor is operated at more than the allowable radial load, the shaft may suffer damage due to fatigue.

Note 7. Applying an excessive load even once can damage the bearings and eventually cause a breakdown.

5-2-5 Encoder Specifications

Item	Standards
Encoder method	Optical incremental encoder
Number of output pulses	A, B phase: 2,048 pulses/revolution Z phase: 1 pulse/revolution
Power supply voltage	5 VDC \pm 5%
Power supply current	DC, 350 mA (for load resistance of 220 Ω)
Phase characteristics	90° \pm 43.2°
Phase relationship	For rotation in the CW direction, A phase is advanced by 90° compared to B phase.
Maximum rotational speed	4500 r/min
Maximum response frequency	153.6 kHz
Output signals	+A, -A, +B, -B, +S, -S
Output impedance	Conforming to EIA RS-422A. Output based on AM26LS31CN or equivalent.
Serial communications data	Z phase, poll sensor, U, V, W phase
Serial communications method	Combination communications method based on A, B, and S phases.

5-3 Cable Specifications

5-3-1 Controller Connecting Cables

Connector-Terminal Block Conversion Unit Cables

Types of Cable

Model	Length (L)	Outer diameter of sheath
R88A-CTU001N	1 m	9.9 dia.
R88A-CTU002N	2 m	

Connection Configuration

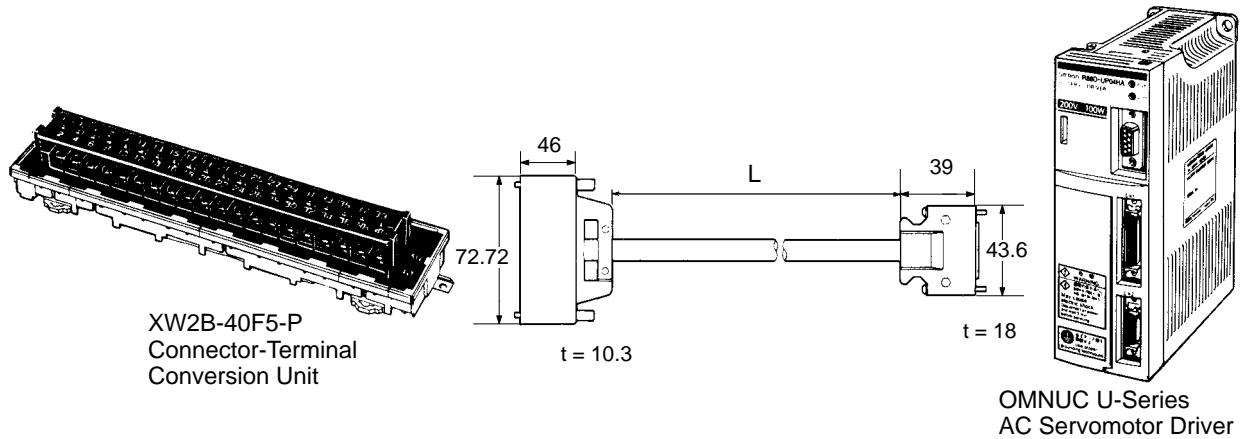

Wiring

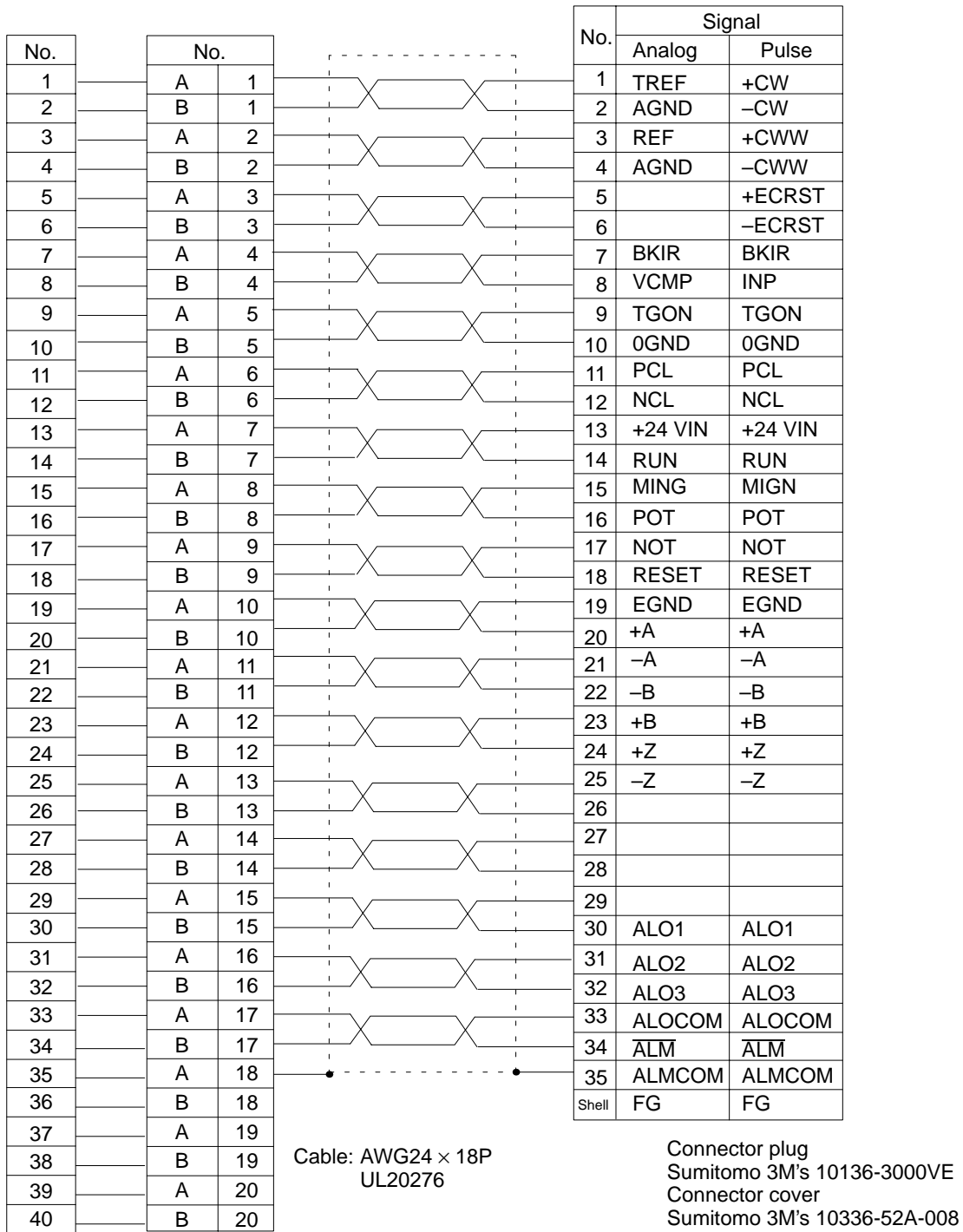

Connector plug: Fujitsu's FCN-361J040-AU
Connector cover: Fujitsu's FCN-360C040-B

□ General-purpose Control Cable

Types of Cable

Model	Length (L)	Outer diameter of sheath
R88A-CPU001S	1 m	9.9 dia.
R88A-CPU002S	2 m	

Connection Configuration

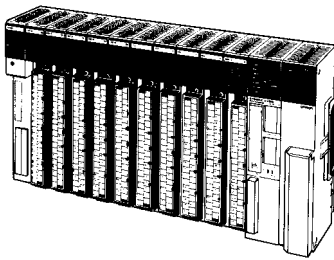

Position Control Unit
mounted on a SYSMAC
C/CV-series PC

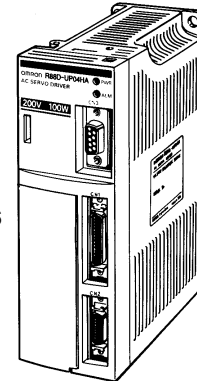
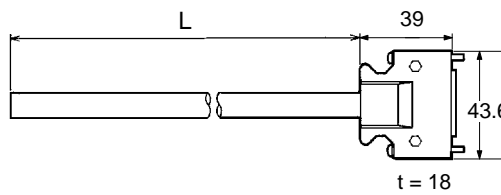

OMNUC U-Series
AC Servomotor Driver

Wiring

No.	Insulation color	Dot mark	Dot mark color	Signal name	
				Analog	Pulse
1	Orange	—	Black	TREF	+CW
2	Orange	—	Red	AGND	—CW
3	Gray	—	Black	REF	+CCW
4	Gray	—	Red	AGND	—CCW
5	White	—	Black		+ECRST
6	White	—	Red		—ECRST
7	Yellow	—	Black	BKIR	BKIR
8	Yellow	—	Red	VCMP	INP
9	Pink	—	Black	TGON	TGON
10	Pink	—	Red	0GND	0GND
11	Gray	--	Black	PCL	PCL
12	Gray	--	Red	NCL	NCL
13	Orange	--	Black	+24VIN	+24VIN
	Orange	--	Red		
14	White	--	Black	RUN	RUN
15	White	--	Red	MING	MING
16	Yellow	--	Black	POT	POT
17	Yellow	--	Red	NOT	NOT
18	Pink	--	Black	RESET	RESET
19	Pink	--	Red	EGND	EGND
20	Orange	----	Black	+A	+A
21	Orange	----	Red	—A	—A
22	Gray	----	Black	—B	—B
23	Gray	----	Red	+B	+B
24	White	----	Black	+Z	+Z
25	White	----	Red	—Z	—Z
26	Yellow	----	Black		
27	Yellow	----	Red		
28	Pink	----	Black		
29	Pink	----	Red		
30	Orange	-----	Black	ALO1	ALO1
31	Orange	-----	Red	ALO2	ALO2
32	Gray	-----	Black	ALO3	ALO3
33	Gray	-----	Red	ALOCOM	ALOCOM
34	White	-----	Black	ALM	ALM
35	White	-----	Red	ALMCOM	ALMCOM
Shell	Shield	---	---	FG	FG

Connector Pin Arrangement

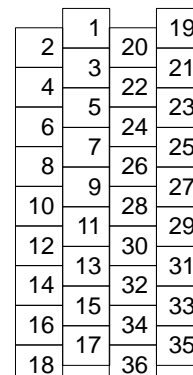

Connector plug model:
10136-3000VE
(Sumitomo 3M)
Connector case model:
10336-52A0-008
(Sumitomo 3M)

Cable: AWG24X18P
UL20276

5-3-2 Encoder Cables

Encoder Cables for Models Conforming to UL/cUL Standards and Models Not Conforming to Any Standards

Types of Cable

Model	Length (L)	Outer diameter of sheath
R88A-CRU003C	3 m	8 dia.
R88A-CRU005C	5 m	
R88A-CRU010C	10 m	
R88A-CRU015C	15 m	
R88A-CRU020C	20 m	

(Up to a maximum of 20 m between the Monitor and the Servo Driver.)

Connection Configuration

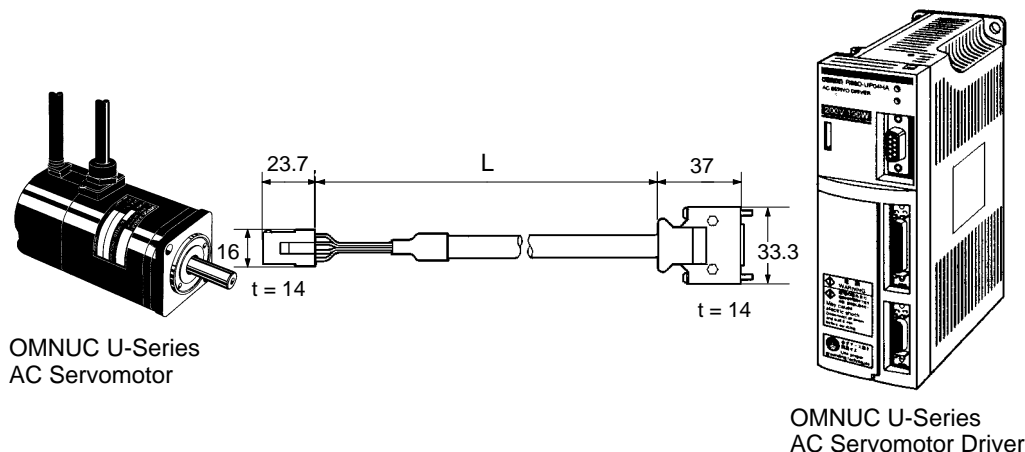

Wiring

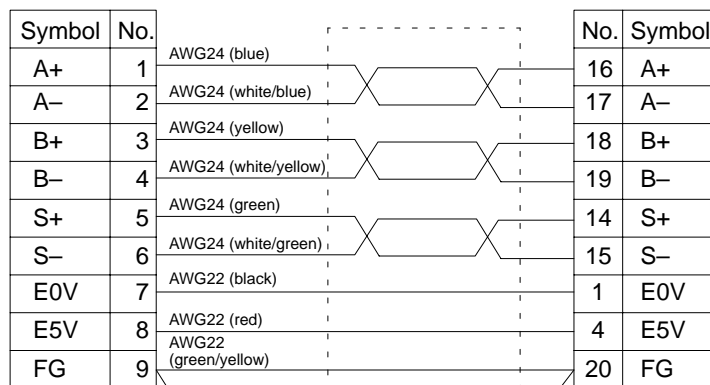

Cable: AWG22 × 3C + AWG24 × 3P
UL2589

<For Cable>

Connector housing model: 172161-1 (Tyco Electronics AMP)
 Connector socket contact model: 170365-1 (Tyco Electronics AMP)
 Crimping tool: 724649-1
 Pulling tool: 724668-2
 Connector plug model: 10120-3000VE (Sumitomo 3M)
 Connector case model: 10320-52A0-008 (Sumitomo 3M)

<For Motor>

Connector plug model: 172169-1 (Tyco Electronics AMP)
 Connector pin contact model: 170359-1 (Tyco Electronics AMP)

Encoder Cables for Models Conforming to EC Directives

Types of Cable

Model	Length (L)	Outer diameter of sheath
R88A-CRUD003C	3 m	8 dia.
R88A-CRUD005C	5 m	
R88A-CRUD010C	10 m	
R88A-CRUD015C	15 m	
R88A-CRUD020C	20 m	

(Up to a maximum of 20 m between the Monitor and the Servo Driver.)

Connection Configuration

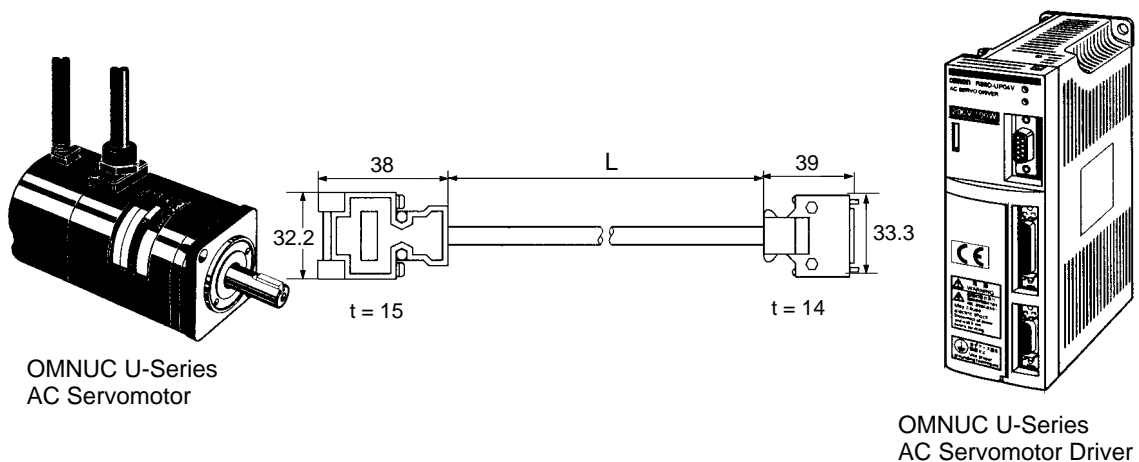

Wiring

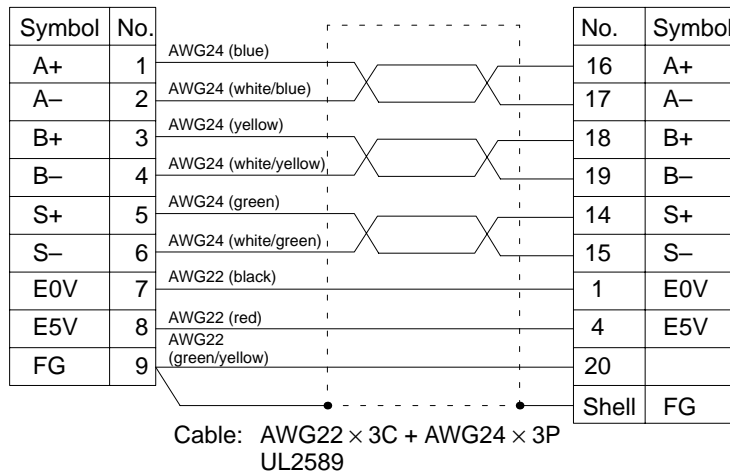

<For Cable>

Connector model: 17J E 13090-02D8A (DDK) Connector plug model: 10120-3000VE (Sumitomo 3M)
 Stud model: 17L-002A1 (DDK) Connector case model: 10320-52A0-008 (Sumitomo 3M)

<For Motor>

Connector: 17JE-23090-02D8A (DDK)

5-3-3 Power Cable

Power Cable for Servomotors Without Brakes, Models Conforming to UL/cUL Standards and Models Not Conforming to Any Standards

Types of Cable

Model	Length (L)	Outer diameter of sheath
R88A-CAU003S	3 m	5.8 dia.
R88A-CAU005S	5 m	
R88A-CAU010S	10 m	
R88A-CAU015S	15 m	
R88A-CAU020S	20 m	

(Up to a maximum of 20 m between the Monitor and the Servo Driver.)

Connection Configuration

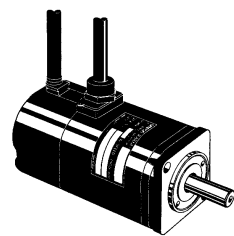

OMNUC U-Series
AC Servomotor

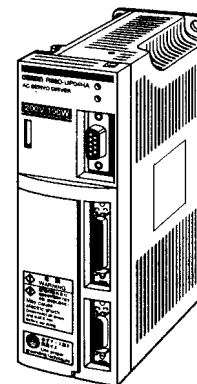
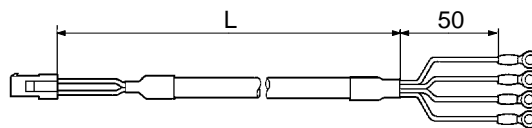

OMNUC U-Series
AC Servomotor Driver

Wiring

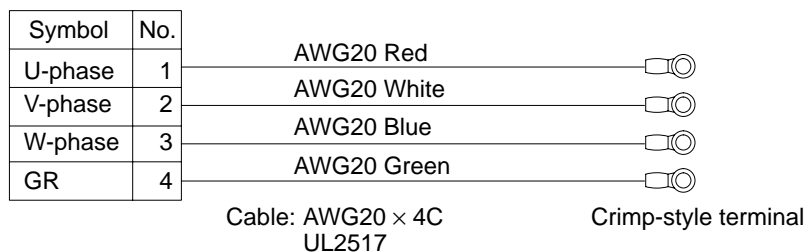

<For Cable>

Connector housing model: 172159-1 (Tyco Electronics AMP)
 Connector socket contact model: 170366-1 (Tyco Electronics AMP)
 Crimping tool: 724651-1
 Pulling tool: 724668-2

<For Motor>

Connector plug model: 172167-1 (Tyco Electronics AMP)
 Connector pin contact model: 170359-1 (Tyco Electronics AMP) for 30 to 100-W models
 170360-1 (Tyco Electronics AMP) for 200 to 750-W models

Power Cable for Servomotors With Brakes, Models Conforming to UL/cUL Standards and Models Not Conforming to Any Standards

Types of Cable

Model	Length (L)	Outer diameter of sheath
R88A-CAU003B	3 m	6.8 dia.
R88A-CAU005B	5 m	
R88A-CAU010B	10 m	
R88A-CAU015B	15 m	
R88A-CAU020B	20 m	

(Up to a maximum of 20 m between the Monitor and the Servo Driver.)

Connection Configuration

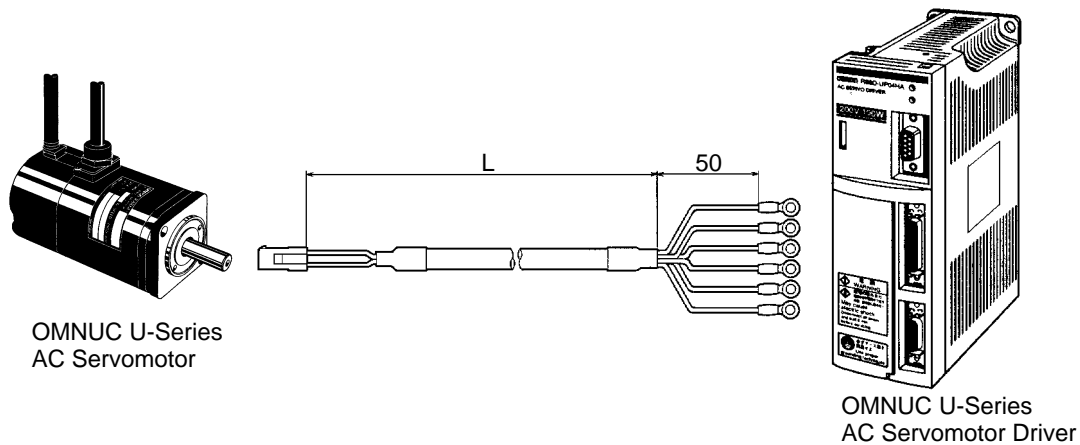

Wiring

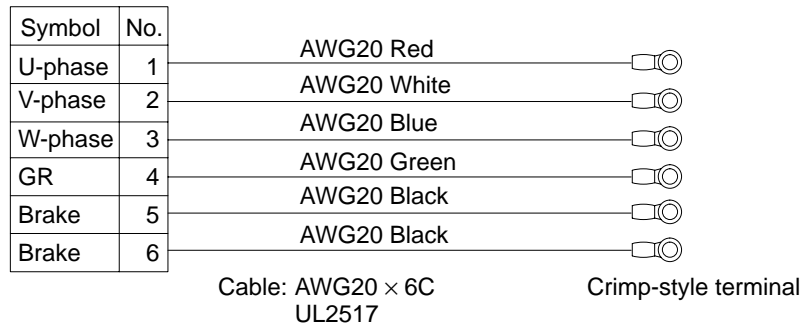

<For Cable>

Connector housing model: 172160-1 (Tyco Electronics AMP)
 Connector socket contact model: 170366-1 (Tyco Electronics AMP)
 Crimping tool: 724651-1
 Pulling tool: 724668-2

<For Motor>

Connector plug model: 172168-1 (Tyco Electronics AMP)
 Connector pin contact model: 170359-1 (Tyco Electronics AMP) 30 to 100-W models
 170360-1 (Tyco Electronics AMP) 200 to 750-W models

Power Cable for Servomotors Without Brakes, Models Conforming to EC Directives

Types of Cable

Model	Length (L)	Outer diameter of sheath
R88A-CAU001	1 m	5.8 dia.

Note 1. Power cables will be cut to the specified length in 1-m increments.

Note 2. The maximum distance between the Servomotor and the Servo Driver is 20 m.

Connection Configuration

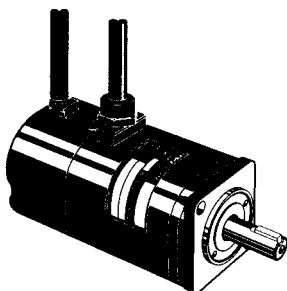

OMNUC U-Series
AC Servomotor

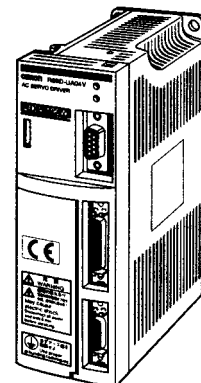
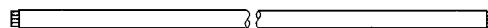

OMNUC U-Series
AC Servomotor Driver

Wiring

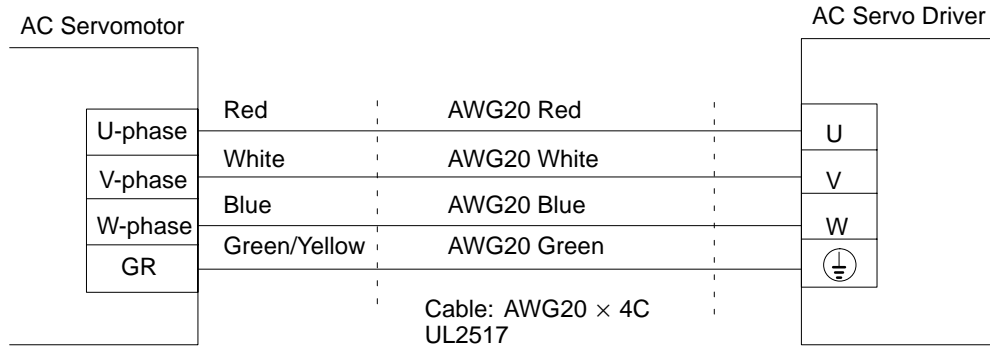

Power Cable for Servomotors With Brakes, Models Conforming to EC Directives

Model	Length (L)	Outer diameter of sheath
R88A-CAU01B	1 m	6.8 dia.

Note 1. Power cables will be cut to the specified length in 1-m increments.

Note 2. The maximum distance between the Servomotor and the Servo Driver is 20 m.

Connection Configuration

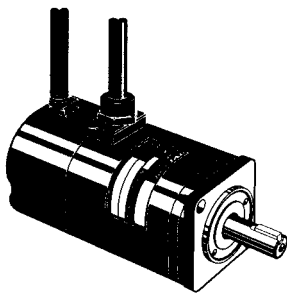

OMNUC U-Series
AC Servomotor

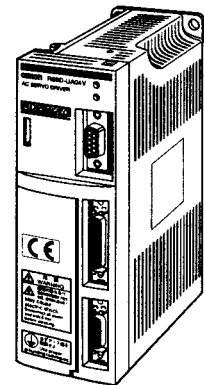
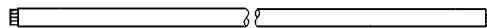

OMNUC U-Series
AC Servomotor Driver

Wiring

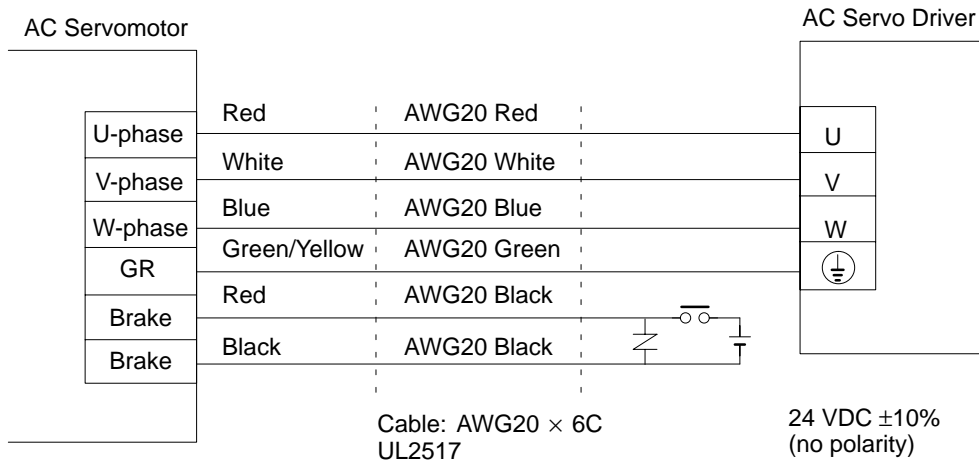

5-4 Parameter Unit Specifications

General Specifications

Item	Standards
Operating ambient temperature	0°C to 55°C
Storage ambient temperature	-10°C to 75°C
Operating ambient humidity	35% to 85% RH (with no condensation)
Storage ambient humidity	35% to 85% RH (with no condensation)
Storage and operating atmosphere	No corrosive gasses.
Vibration resistance	4.9 m/s ² max.
Impact resistance	Acceleration 19.6 m/s ² max.

Performance Specifications

Model		R88A-PR02U	R88A-PR03U
Type		Hand held	Mounted
Accessory cable		1,000 mm	(Connected by connectors.)
Accessory connectors		7910-7500SC (10 pins)	D sub-connector (9 pins)
Display		7-segment LED, 5 digits	
External dimensions		63 × 135 × 18.5 (W × H × D)	54 × 57.5 × 15 (W × H × D)
Communi- cations specifica- tions	Standard	RS-232C	RS-422A
	Communications method	Asynchronous (ASYNC)	
	Baud rate	2,400 bps	
	Start bits	1 bit	
	Data	8 bits	
	Parity	None	
	Stop bits	1 bit	
Errors detected by Parameter Unit	Display	CPF00	Cannot transmit even after 5 seconds have elapsed since power supply was turned on.
		CPF01	A BCC error or faulty reception data has occurred for five consecutive times, or a time overrun (1 s) has occurred for three consecutive times.

5-5 Regeneration Unit Specifications

□ R88A-RG08UA Regeneration Unit

General Specifications

Item	Standards
Operating ambient temperature	0°C to 55°C
Storage ambient temperature	-10°C to 75°C
Operating ambient humidity	35% to 85% RH (with no condensation)
Storage ambient humidity	35% to 85% RH (with no condensation)
Storage and operating atmosphere	No corrosive gasses.
Vibration resistance	4.9 m/s ² max.
Impact resistance	Acceleration 19.6 m/s ² max.

Performance Specifications

Model	R88A-RG08UA
Regeneration operating voltage	380 V _{DC}
Regeneration processing current	8 A _{DC}
Average regeneration power	12 W (internal resistance: 50 Ω, 60 W)
Externally connected regeneration resistance	47 Ω±5%
Error detection function	Regeneration resistance disconnection, regeneration transistor damage, overvoltage
Alarm output	SPST-NC contact (open contact at time of protective function operation) (200 VAC drive possible.)
External dimensions	55 × 160 × 130 (W × H × D)

Indicator LED Specifications

Name	Specifications
POWER	Lit while power flows between P and N terminals.
REGEN	Lit during regeneration operation.
ALARM-REGEN	Lit for regeneration resistance disconnection or regeneration transistor damage.
ALARM-OV	Lit when overvoltage occurs.

- Note 1.** When the error detection function operates, an alarm is output from the Unit.
- Note 2.** Create a sequence so that the power supply (R-T) to the Servo Driver is cut off when an alarm is generated.
- Note 3.** When the error detection function operates and the Servo Driver's power supply is cut off, the Regeneration Unit won't be restored to its normal status until 2 to 3 seconds have elapsed, even if the power supply is turned on again. (Normal status is restored after the electrolytic capacitor in the Servo Driver has been discharged and the voltage between P and N drops.)
- Note 4.** Does not conform to EC Directives.

5-6 Front-surface Mounting Bracket Specifications

The Front-surface Mounting Brackets (R88A-TK01U/TK02U) are used to mount a Servo Driver from the front surface. The model of the Bracket depends on the model of the Servo Driver.

These Mounting Brackets cannot be used with models conforming to EC Directives.

Combinations

Servo Driver			Front-surface Mounting Bracket model
Model	Supply voltage	Power	
R88D-UP02H(A)	200 V	30 W	R88A-TK01U
R88D-UP03H(A)		50 W	
R88D-UP04H(A)		100 W	
R88D-UP08H(A)		200 W	
R88D-UP12H(A)		400 W	
R88D-UP20H(A)		750 W	
R88D-UP03L(A)	100 V	30 W	R88A-TK01U
R88D-UP04L(A)		50 W	
R88D-UP10L(A)		100 W	
R88D-UP12L(A)		200 W	
R88D-UP15LA		300 W	R88A-TK02U

Note The Brackets come with a top bracket, a bottom bracket, and five mounting screws.

□ Dimensions

R88A-TK01U

Top Mounting Bracket

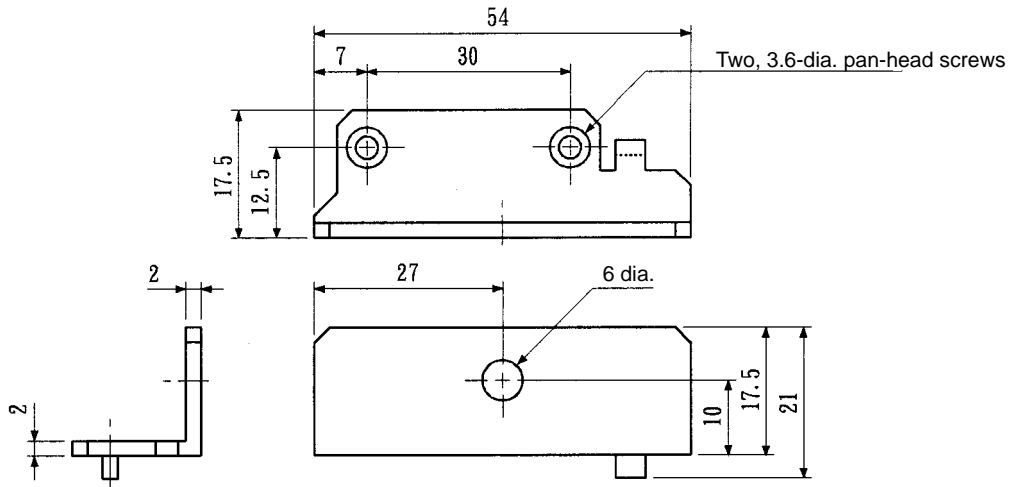

Bottom Mounting Bracket

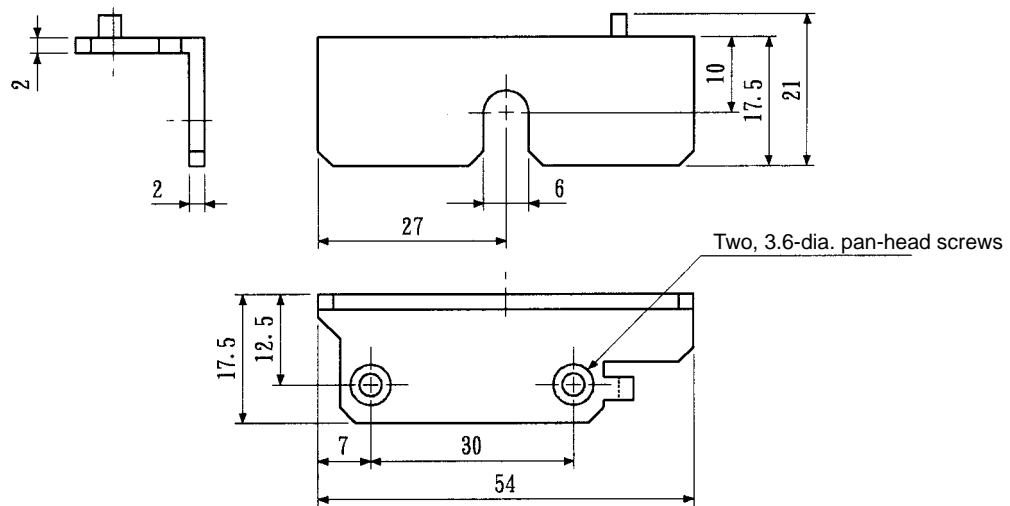

R88A-TK02U

Top Mounting Bracket

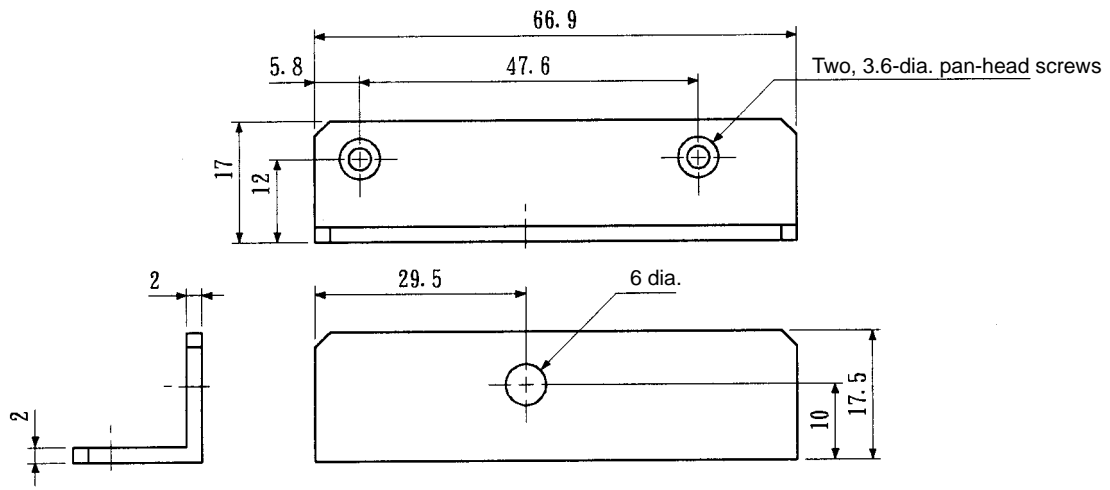

Bottom Mounting Bracket

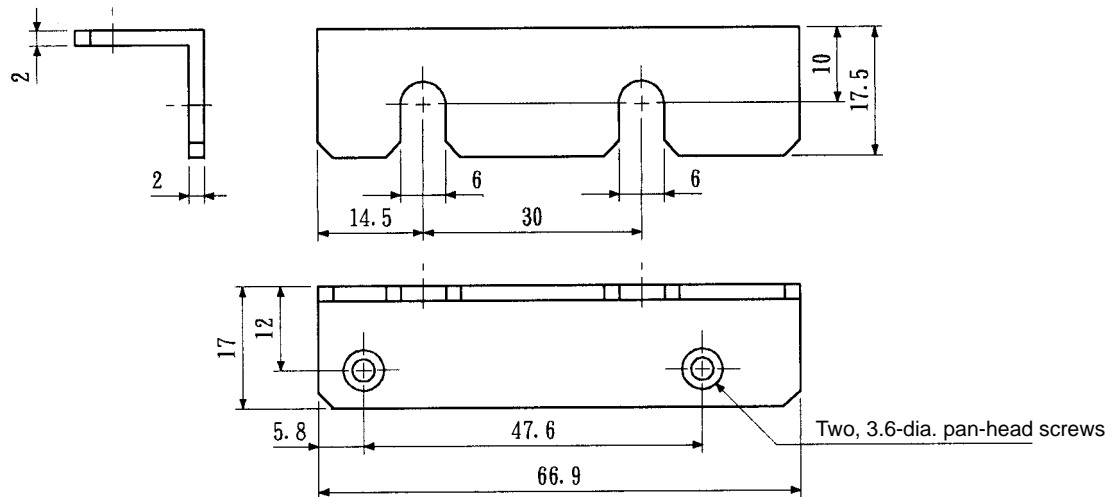

□ Mounting Dimensions

R88A-TK01U

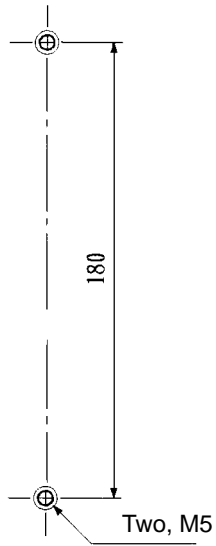

R88A-TK02U

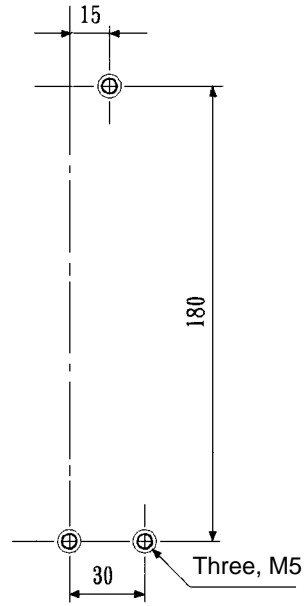

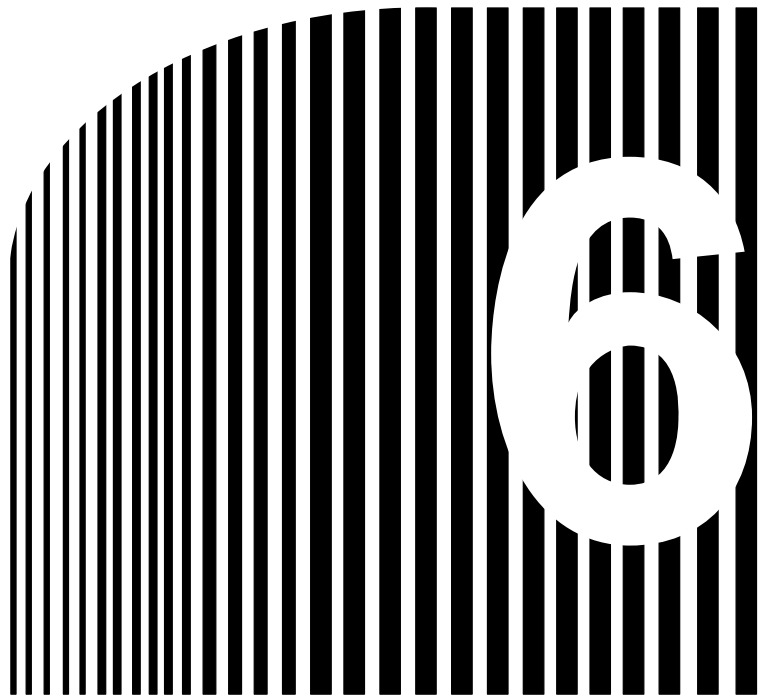

Chapter 6

• **Supplementary Materials** •

- 6-1 Connection Examples
- 6-2 Servo Connector Terminal Connection Unit
- 6-3 OMNUC U-series Standard Models
- 6-4 Parameter Setting Forms

6-1 Connection Examples

□ Connecting to SYSMAC C200H-NC112 Position Control Unit with 5-VDC Power Supply

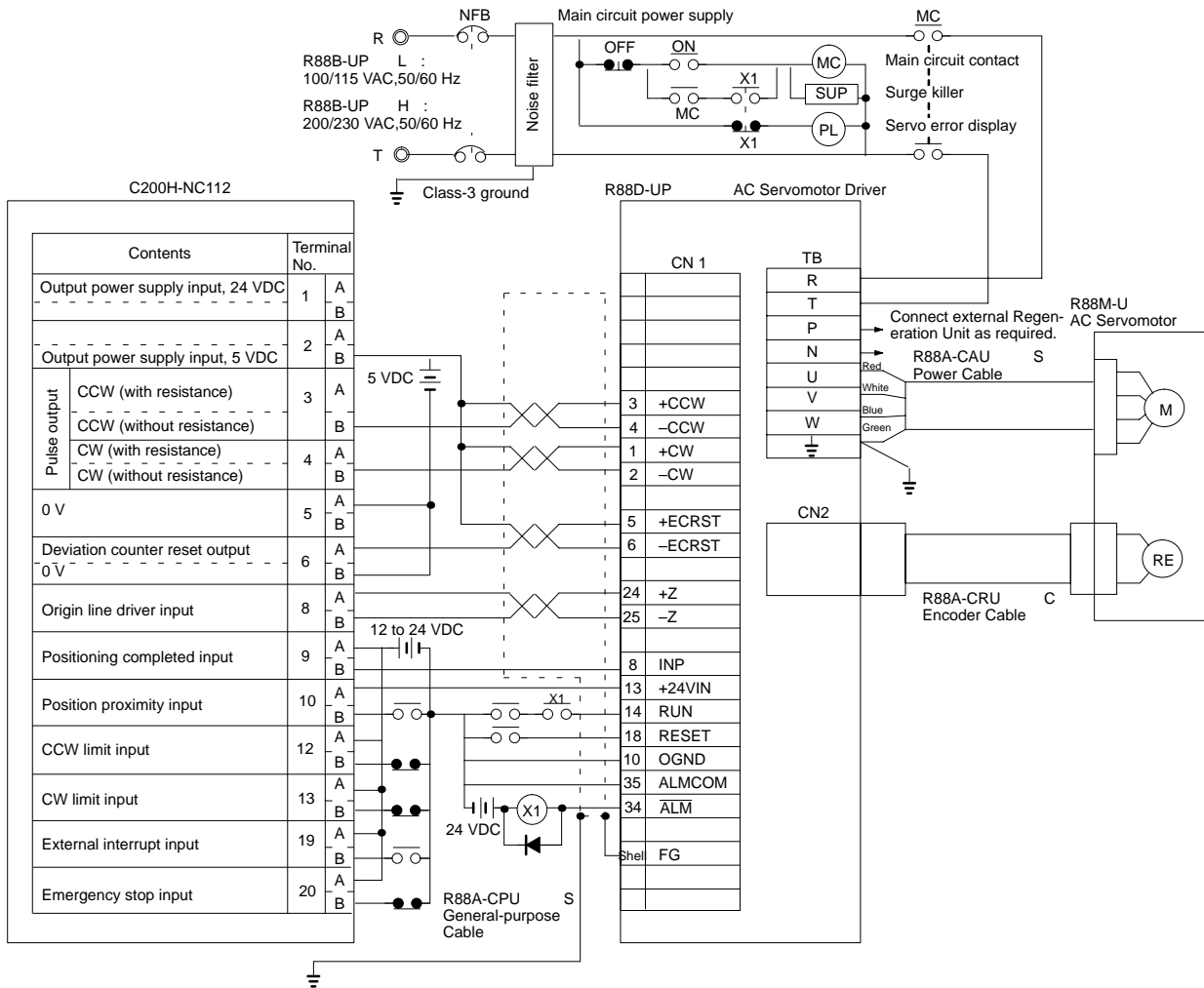

Note 1. Incorrect signal wiring can cause damage to Units and the Servo Driver.

Note 2. Leave unused signal lines open and do not wire them.

Note 3. Use mode 2 for origin search.

Note 4. Use a dedicated power supply (5 VDC) for command pulse signals.

Note 5. ERB44-02 diodes (by Fuji Electric) or equivalent are recommended for surge absorption.

Note 6. Use the RUN signal to set whether the Servo can be turned ON/OFF.

□ Connecting to SYSMAC C200H-NC112 Position Control Unit with 24-VDC Power Supply

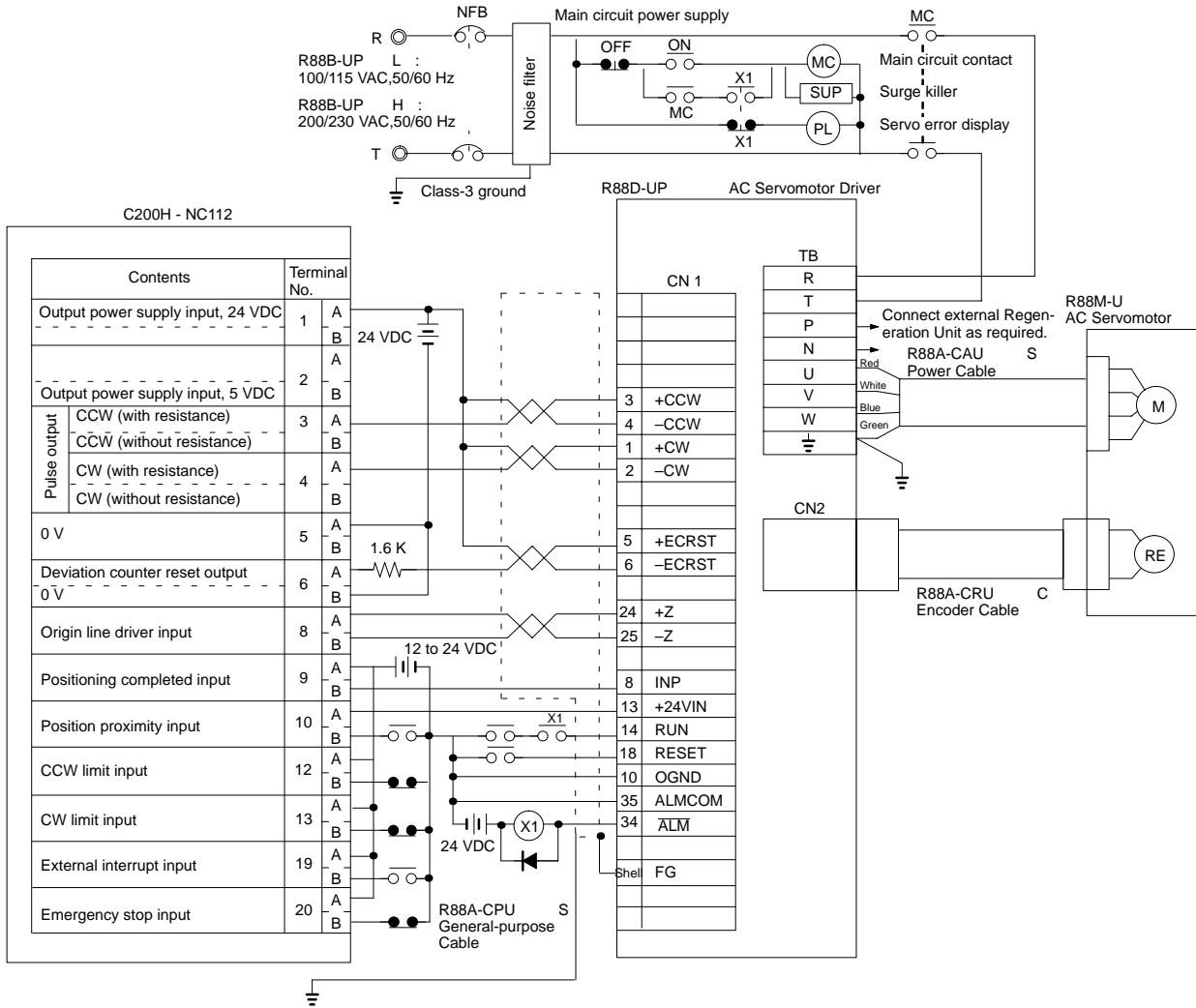

Note 1. Incorrect signal wiring can cause damage to Units and the Servo Driver.

Note 2. Leave unused signal lines open and do not wire them.

Note 3. Use mode 2 for origin search.

Note 4. Use a dedicated power supply (24 VDC) for command pulse signals.

Note 5. ERB44-02 diodes (by Fuji Electric) or equivalent are recommended for surge absorption.

Note 6. Use the RUN signal to set whether the Servo COM can be turned ON/OFF.

□ Connecting to SYSMAC C200H-NC211 and C500-NC113/211 Position Control Unit with 5-VDC Power Supply

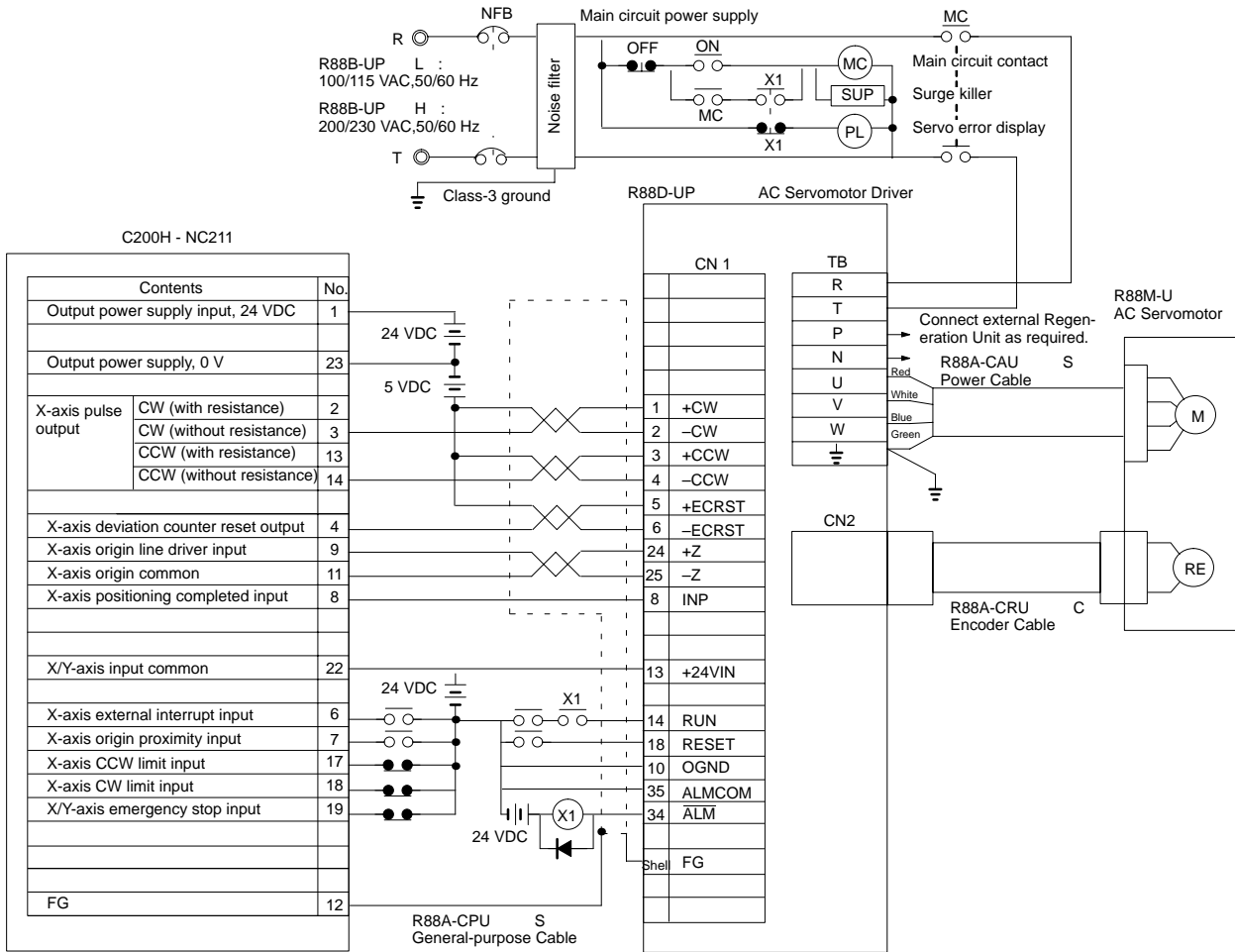

Note 1. Incorrect signal wiring can cause damage to Units and the Servo Driver.

Note 2. Leave unused signal lines open and do not wire them.

Note 3. Use mode 2 for origin search.

Note 4. Use a dedicated power supply (5 or 24 VDC) for command pulse signals.

Note 5. ERB44-02 diodes (by Fuji Electric) or equivalent are recommended for surge absorption.

Note 6. This wiring diagram is an example of X-axis wiring only. If two-axis control is used, the external input and Servo Driver wiring must be done in the same way for the Y axis.

Note 7. Use the RUN signal to set whether the Servo can be turned ON/OFF.

□ Connecting to SYSMAC C200H-NC211 and C500-NC113/211 Position Control Unit with 24-VDC Power Supply

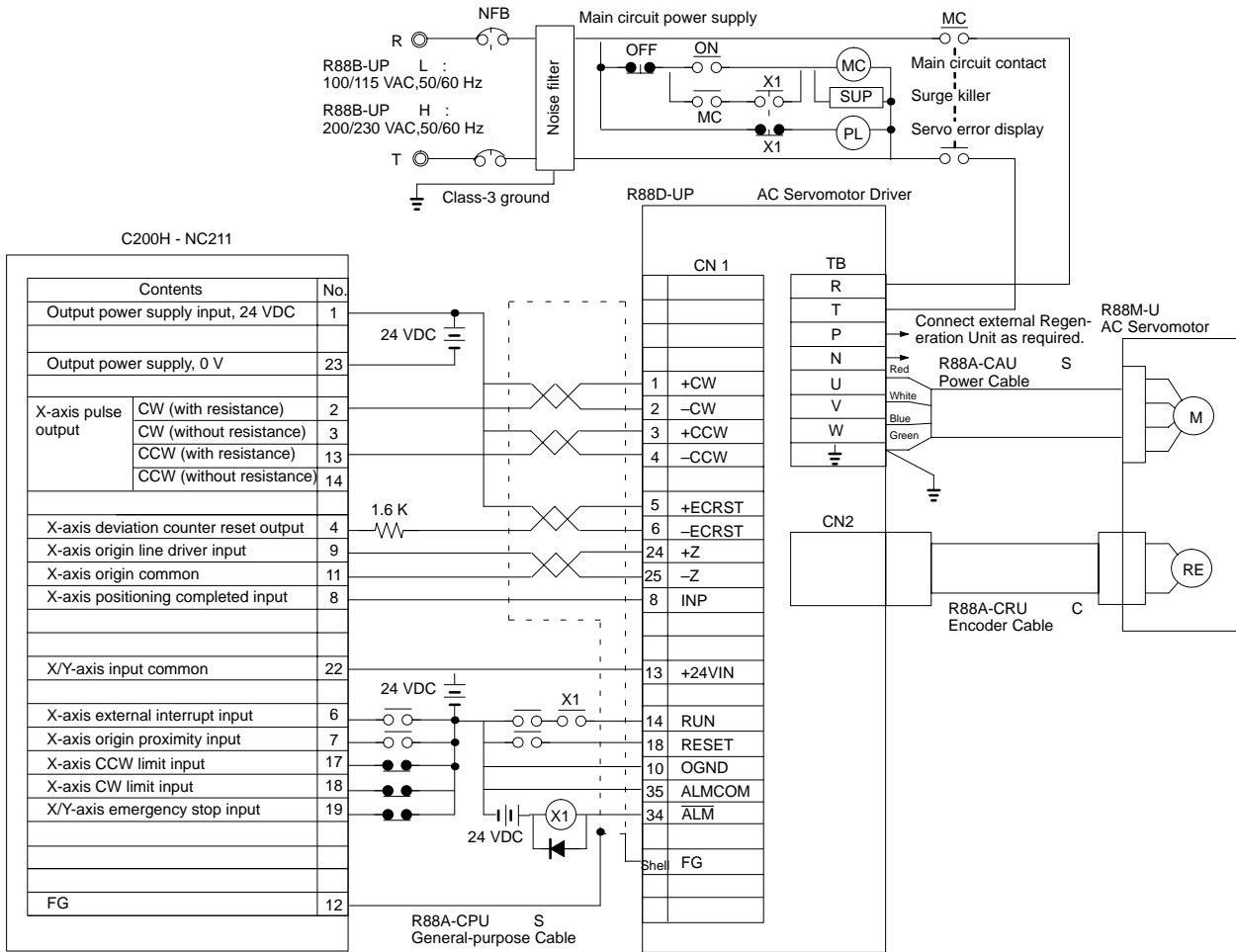

Note 1. Incorrect signal wiring can cause damage to Units and the Servo Driver.

Note 2. Leave unused signal lines open and do not wire them.

Note 3. Use mode 2 for origin search.

Note 4. Use a dedicated power supply (24 VDC) for command pulse signals.

Note 5. ERB44-02 diodes (by Fuji Electric) or equivalent are recommended for surge absorption.

Note 6. This wiring diagram is an example of X-axis wiring only. If two-axis control is used, the external input and Servo Driver wiring must be done in the same way for the Y axis.

Note 7. Use the RUN signal to set whether the Servo can be turned ON/OFF.

□ Connecting to SYSMAC 3G2A5-NC111-EV1 Position Control Unit

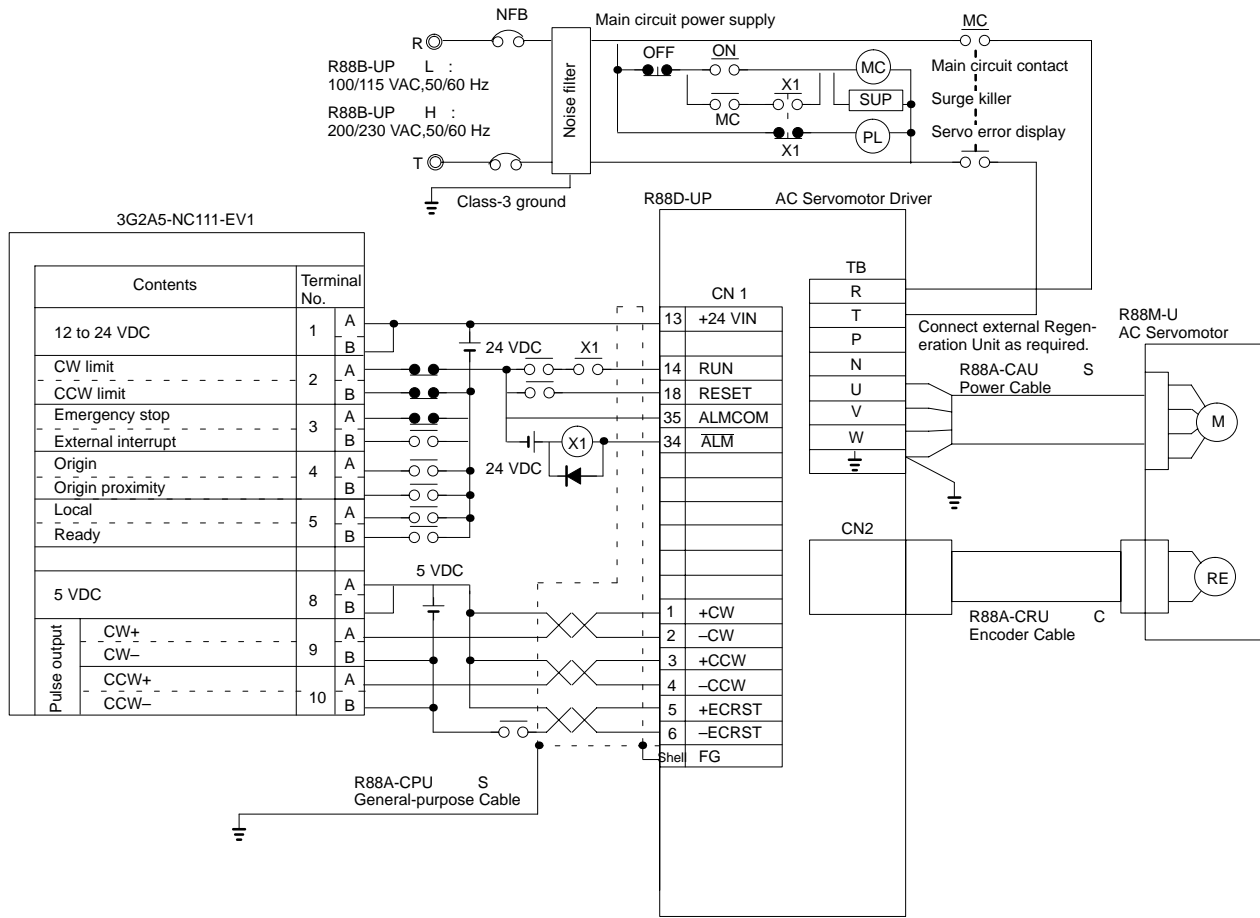

Note 1. Incorrect signal wiring can cause damage to Units and the Servo Driver.

Note 2. Leave unused signal lines open and do not wire them.

Note 3. ERB44-02 diodes (by Fuji Electric) or equivalent are recommended for surge absorption.

Note 4. When using a 3G2A5-NC111-EV1 Position Control Unit, origin search is carried out according to the origin and origin proximity inputs. Set the origin and origin proximity for the mechanical system. Even after the 3G2A5-NC111-EV1 completes the origin search and pulses are stopped, pulses are still accumulated in the deviation counter in the Servo Driver. The Servomotor will move for the amount of residual pulses and then stop, so there may be a discrepancy with the origin. In order to minimize the amount of the discrepancy, set the origin search proximity speed as low as possible.

Note 5. Use the RUN signal to set whether the Servo can be turned ON/OFF.

□ Connecting to SYSMAC C200HW-NC113/213/413 Position Control Units (24-VDC Power Supply)

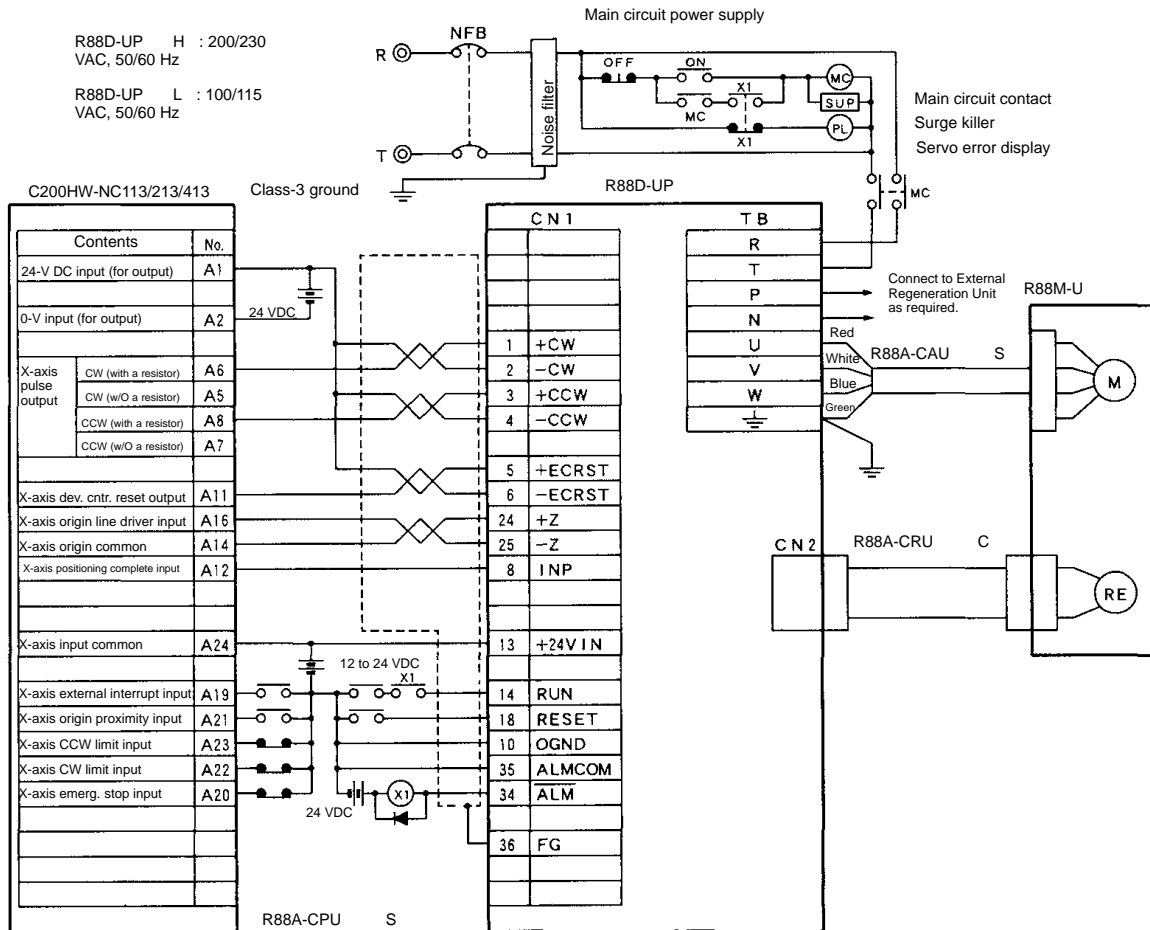

- Note 1.** Incorrect signal wiring can cause damage to Units and the Servo Driver.
- Note 2.** Leave unused signal lines open and do not wire them.
- Note 3.** Use mode 2 for origin search.
- Note 4.** Use the 24-VDC power supply for command pulse signals as a dedicated power supply.
- Note 5.** The diode recommended for surge absorption is the ERB44-02 (Fuji Electric).
- Note 6.** This diagram shows a connection example for the X axis only. For 2-axis control, connect an external input and Servo Driver for the Y axis as well.
- Note 7.** Make the setting so that the Servo can be turned ON and OFF with the RUN signal.
- Note 8.** The maximum response for the pulse command input of the U-series Servo Driver is 200 kpps.

6-2 Servo Connector Terminal Connection Unit

Terminal Connection Unit for C200H-NC112
XW2B-20J6-1B

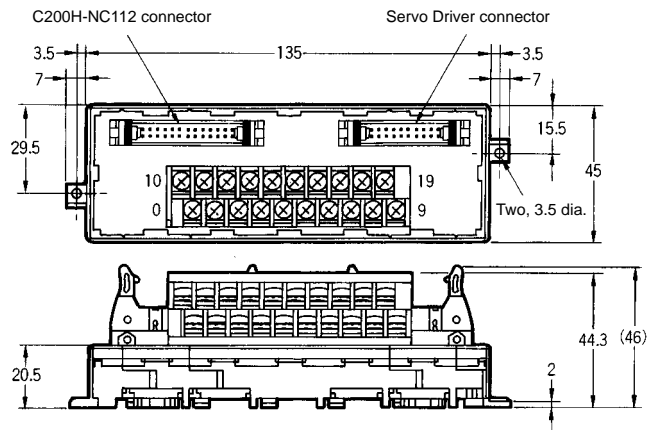
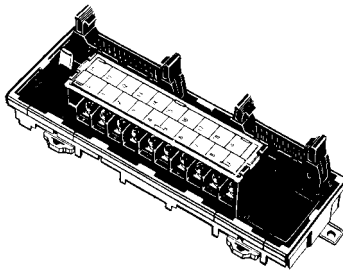

Note: Terminal block pitch: 7.62 mm

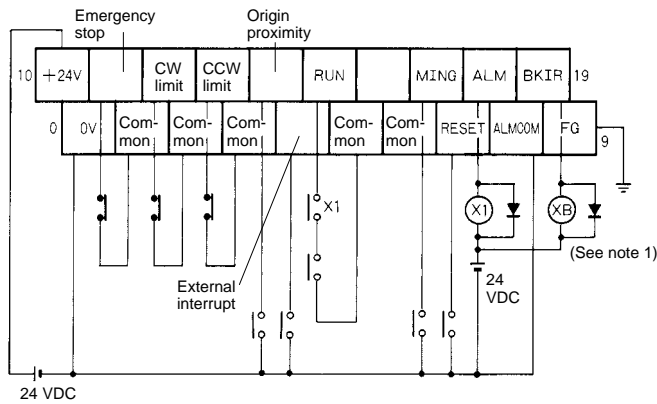

- Note 1.** The XB contact is used to turn ON/OFF the electromagnetic brake.
- Note 2.** Do not connect unused terminals.
- Note 3.** The 0 V terminal is internally connected to the common terminals.
- Note 4.** The following crimp terminal is applicable: R1.25-3 (round with open end).

Terminal Connection Unit for C200H-NC211
XW2B-40J6-2B

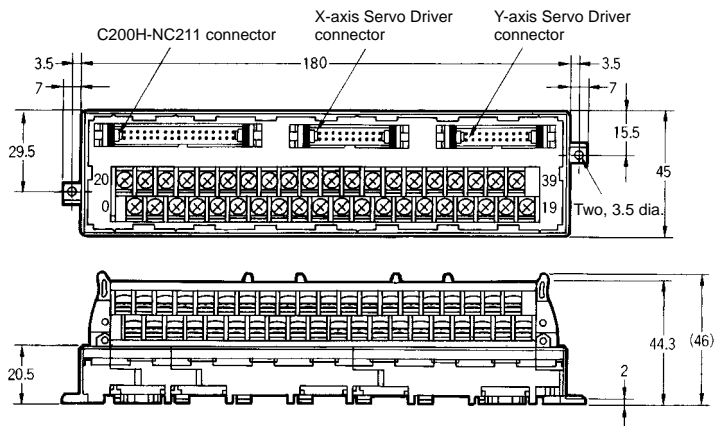
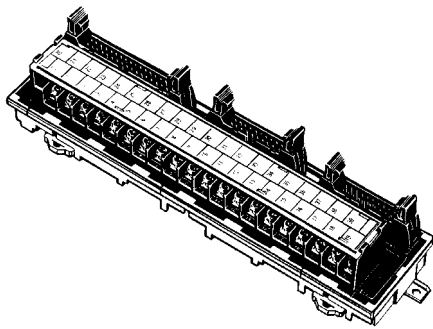

Note: Terminal block pitch: 7.62 mm

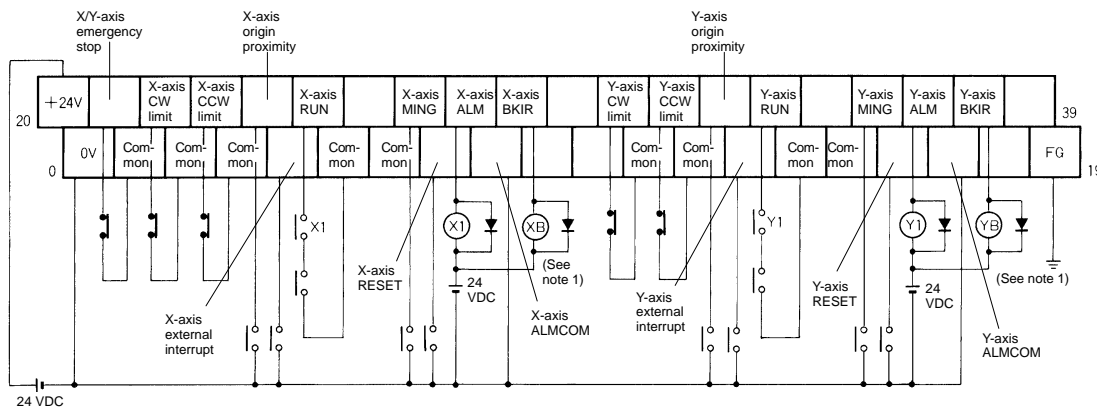

Note 1. The XB contact is used to turn ON/OFF the electromagnetic brake.

Note 2. Connect the CW and CCW limit signals to a common terminal when controlling one axis.

Note 3. Do not connect unused terminals.

Note 4. The 0 V terminal is internally connected to the common terminals.

Note 5. The following crimp terminal is applicable: R1.25-3 (round with open end).

**Terminal Connection Unit for CQM1-CPU43-V1, CQM1H-PLB21
XW2B-20J6-3B**

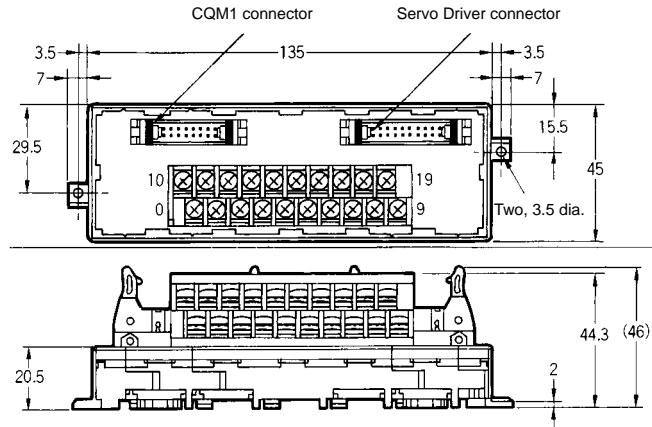
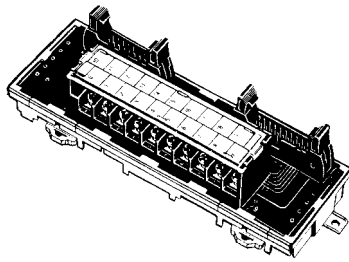

Note: Terminal block pitch: 7.62 mm

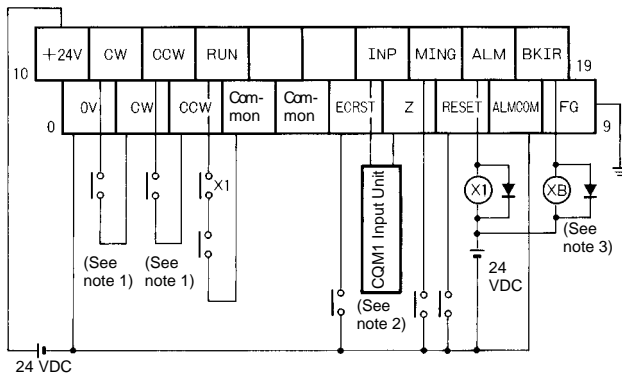

- Note 1.** Inputting this signal will cause the CQM1's output pulse to be returned and input to the high-speed counter.
- Note 2.** Input this output signal to a CQM1's Input Unit.
- Note 3.** The XB contact is used to turn ON/OFF the electromagnetic brake.
- Note 4.** An open-collector output is used for the Z phase.
- Note 5.** Do not connect unused terminals.
- Note 6.** The 0 V terminal is internally connected to the common terminals.
- Note 7.** The following crimp terminal is applicable: R1.25-3 (round with open end).

6-3 OMNUC U-series Standard Models

Models Conforming to UL/cUL Standards and Models Not Conforming to Any Standards

Servomotors

Specification				Model
Straight shaft with no key	Standard (no brake)	200 VAC	30 W	R88M-U03030HA
			50 W	R88M-U05030HA
			100 W	R88M-U10030HA
			200 W	R88M-U20030HA
			400 W	R88M-U40030HA
			750 W	R88M-U75030HA
		100 VAC	30 W	R88M-U03030LA
			50 W	R88M-U05030LA
			100 W	R88M-U10030LA
			200 W	R88M-U20030LA
			300 W	R88M-U30030LA
			With brake	200 VAC
	50 W	R88M-U05030HA-B		
	100 W	R88M-U10030HA-B		
	200 W	R88M-U20030HA-B		
	400 W	R88M-U40030HA-B		
	750 W	R88M-U75030HA-B		
	100 VAC	30 W	R88M-U03030LA-B	
50 W		R88M-U05030LA-B		
100 W		R88M-U10030LA-B		
200 W		R88M-U20030LA-B		
300 W		R88M-U30030LA-B		

Specification			Model	
Straight shafts with keys	Standard (no brake)	200 VAC	30 W	R88M-U03030HA-S1
			50 W	R88M-U05030HA-S1
			100 W	R88M-U10030HA-S1
			200 W	R88M-U20030HA-S1
			400 W	R88M-U40030HA-S1
			750 W	R88M-U75030HA-S1
		100 VAC	30 W	R88M-U03030LA-S1
			50 W	R88M-U05030LA-S1
			100 W	R88M-U10030LA-S1
	With brake	200 VAC	30 W	R88M-U03030HA-BS1
			50 W	R88M-U05030HA-BS1
			100 W	R88M-U10030HA-BS1
			200 W	R88M-U20030HA-BS1
			400 W	R88M-U40030HA-BS1
			750 W	R88M-U75030HA-BS1
		100 VAC	30 W	R88M-U03030LA-BS1
			50 W	R88M-U05030LA-BS1
			100 W	R88M-U10030LA-BS1
		200 W	R88M-U20030LA-BS1	
		300 W	R88M-U30030LA-BS1	

Servo Drivers with Pulse-train Inputs

Specification			Model	
Pulse-train input	200 VAC	30 W	R88D-UP02HA	
		50 W	R88D-UP03HA	
		100 W	R88D-UP04HA	
		200 W	R88D-UP08HA	
		400 W	R88D-UP12HA	
		750 W	R88D-UP20HA	
	100 VAC	30 W	R88D-UP03LA	
		50 W	R88D-UP04LA	
		100 W	R88D-UP10LA	
		200 W	R88D-UP12LA	
		300 W	R88D-UP15LA	

Parameter Unit

Specification	Model
Handy type	R88A-PR02U
Mounted type	R88A-PR03U

Regeneration Unit

Specification	Model
Regeneration processing current: 8 A	R88A-RG08UA

External Regeneration Resistor

Specification	Model
Regeneration capacity: 70 W, 47 Ω	R88A-RR22047S

Encoder Cables

Specification	Model	
Connectors at both ends	3 m	R88A-CRU003C
	5 m	R88A-CRU005C
	10 m	R88A-CRU010C
	15 m	R88A-CRU015C
	20 m	R88A-CRU020C
Cable only	1-m units	R88A-CRU001

Power Cables

Specification	Model		
For standard motors (no brake)	Connector at one end	3 m	R88A-CAU003S
		5 m	R88A-CAU005S
		10 m	R88A-CAU010S
		15 m	R88A-CAU015S
		20 m	R88A-CAU020S
	Cable only	1-m units	R88A-CAU001
For motors with brakes	Connector at one end	3 m	R88A-CAU003B
		5 m	R88A-CAU005B
		10 m	R88A-CAU010B
		15 m	R88A-CAU015B
		20 m	R88A-CAU020B
	Cable only	1-m units	R88A-CAU01B

General-purpose Control Cables

Specification	Model	
For general-purpose controllers, connector at one end	1 m	R88A-CPU001S
	2 m	R88A-CPU002S

Servo Relay Units

Specification		Model	
Servo Relay Unit	C200H-NC112 C200HW-NC113	XW2B-20J6-1B	
	C200H-NC211 C500-NC113/211 C200HW-NC213/413	XW2B-40J6-2B	
	CQM1-CPU43-V1 CQM1H-PLB21	XW2B-20J6-3B	
Servo Driver Cable	1 m	XW2Z-100J-B1	
	2 m	XW2Z-200J-B1	
Position Control Unit Cable	C200H-NC112	0.5 m	XW2Z-050J-A1
		1 m	XW2Z-100J-A1
	C200H-NC211 C500-NC113/211	0.5 m	XW2Z-050J-A2
		1 m	XW2Z-100J-A2
	CQM1-CPU43-V1 CQM1H-PLB21	0.5 m	XW2Z-050J-A3
		1 m	XW2Z-100J-A3
	C200HW-NC113	0.5 m	XW2Z-050J-A6
		1 m	XW2Z-100J-A6
	C200HW-NC213 C200HW-NC413	0.5 m	XW2Z-050J-A7
		1 m	XW2Z-100J-A7

Connectors, Terminal Blocks and Peripheral Cable

Specification		Model
Control cable connector		R88A-CNU01C
Connector terminal block		XW2B-40F5-P
Connection cable for connector terminal block	1 m	R88A-CTU001N
	2 m	R88A-CTU002N
Analog monitor cable		R88A-CMW001S

Front-surface Mounting Brackets

Specification	Model
For the following Servo Drivers 200 VAC: 30 to 400 W 100 VAC: 30 to 200 W	R88A-TK01U
For the following Servo Drivers 200 VAC: 750 W 100 VAC: 300 W	R88A-TK02U

Note HA/LA models: Models manufactured after May 1998 conform to UL/cUL Standards.
H/L models: Do not conform to UL/cUL Standards.

Models Conforming to EC Directives

Servomotors

Specification			Model	
Straight shafts with keys	Standard (no brake)	200 VAC	30 W	R88M-U03030VA-S1
			50 W	R88M-U05030VA-S1
			100 W	R88M-U10030VA-S1
			200 W	R88M-U20030VA-S1
			400 W	R88M-U40030VA-S1
			750 W	R88M-U75030VA-S1
	100 VAC	200 VAC	30 W	R88M-U03030WA-S1
			50 W	R88M-U05030WA-S1
			100 W	R88M-U10030WA-S1
			200 W	R88M-U20030WA-S1
			300 W	R88M-U30030WA-S1
			With brake	200 VAC
	50 W	R88M-U05030VA-BS1		
	100 W	R88M-U10030VA-BS1		
	200 W	R88M-U20030VA-BS1		
	400 W	R88M-U40030VA-BS1		
	750 W	R88M-U75030VA-BS1		
	100 VAC	200 VAC		30 W
50 W				R88M-U05030WA-BS1
100 W				R88M-U10030WA-BS1
200 W				R88M-U20030WA-BS1
300 W				R88M-U30030WA-BS1

Servo Drivers with Pulse-train Inputs

Specification		Model		
Pulse-train inputs	200 VAC	30 W	R88D-UP02V	
		50 W	R88D-UP03V	
		100 W	R88D-UP04V	
		200 W	R88D-UP08V	
		400 W	R88D-UP12V	
		750 W	R88D-UP20V	
	100 VAC	200 VAC	30 W	R88D-UP03W
			50 W	R88D-UP04W
			100 W	R88D-UP10W
			200 W	R88D-UP12W
			300 W	R88D-UP15W

Parameter Units

Specification	Model
Handy type	R88A-PR02U
Mounted type	R88A-PR03U

Encoder Cables

Specification		Model
Connectors at both ends	3 m	R88A-CRUD003C
	5 m	R88A-CRUD005C
	10 m	R88A-CRUD010C
	15 m	R88A-CRUD015C
	20 m	R88A-CRUD020C
Cable only	1-m units	R88A-CRU001

Power Cables (Cables Only)

Specification		Model
For standard motor (no brake)	1-m units	R88A-CAU001
For motor with brake	1-m units	R88A-CAU01B

General-purpose Control Cables

Specification		Model
For general-purpose controller, connector at one end	1 m	R88A-CPU001S
	2 m	R88A-CPU002S

Peripheral Cable

Specification		Model
Analog monitor cable	1 m	R88A-CMW001S

6-4 Parameter Setting Forms

User Parameters

PRM No.	Parameter name	Factory setting	Unit	Setting range	Setting
Cn-04	Speed loop gain (See note 1.)	80	Hz	1 to 2,000	
Cn-05	Speed loop integration constant	20	H/L: ms HA/LA/ V/W: ms or 0.01 ms	2 to 10,000	
Cn-06	Emergency stop torque	Maximum torque	%	0 to maximum torque	
Cn-07	Soft start acceleration time	0	ms	0 to 10,000	
Cn-08	Forward torque limit	Maximum torque	%	0 to maximum torque	
Cn-09	Reverse torque limit	Maximum torque	%	0 to maximum torque	
Cn-0A	Encoder divider rate (See note 2.)	1,000	Pulses/revolution	16 to 2,048	
Cn-0b	Rotation speed for motor rotation detection	20	r/min	1 to 4,500	
Cn-0C	P control switching (torque commands)	200	%	0 to maximum torque	
Cn-0d	P control switching (speed commands)	0	r/min	0 to 4,500	
Cn-0E	P control switching (acceleration commands)	0	10 (r/min)/s	0 to 3,000	
Cn-0F	P control switching (deviation pulse)	10	Command units	0 to 10,000	
Cn-10	Jog speed	500	r/min	0 to 4,500	
Cn-11	Number of encoder pulses (See notes 2 and 3.)	2,048	Pulses/revolution	2,048	2,048
Cn-12	Brake timing 1	0	10 ms	0 to 50	
Cn-15	Brake command speed	100	r/min	0 to 4,500	
Cn-16	Brake timing 2	50	10 ms	10 to 100	
Cn-17	Torque command filter time constant	4	100 μs	0 to 250	
Cn-18	Forward rotation external current limit	100	%	0 to maximum torque	
Cn-19	Reverse rotation external current limit	100	%	0 to maximum torque	
Cn-1A	Position loop gain	40	1/s	1 to 500	
Cn-1b	Positioning completion range	3	Command units	0 to 250	
Cn-1C	Bias rotational speed	0	r/min	0 to 450	
Cn-1d	Feed-forward amount	0	%	0 to 100	
Cn-1E	Deviation counter overflow level	1,024	× 256 commands	1 to 32,767	

PRM No.	Parameter name	Factory setting	Unit	Setting range	Setting
Cn-1F	No. 1 internal speed setting	100	r/min	0 to 4,500	
Cn-20	No. 2 internal speed setting	200	r/min	0 to 4,500	
Cn-21	No. 3 internal speed setting	300	r/min	0 to 4,500	
Cn-23	Soft start deceleration time	0	ms	0 to 10,000	
Cn-24	Electronic gear ratio G1 (numerator) (see note 2)	4	---	1 to 65,535	
Cn-25	Electronic gear ratio G2 (denominator) (see note 2)	1	---	1 to 65,535	
Cn-26	Position command acceleration/deceleration time constant	0	× 0.1 ms	0 to 640	
Cn-27	Feed-forward command filter	0	× 0.1 ms	0 to 640	
Cn-28	Compensating gain (HA/LA/V/W Models)	0	---	0 to 100	
Cn-29	Unit number setting (HA/LA/V/W Models) (See note 4)	0	---	0 to 14	

Note 1. Cn-04 (speed loop gain) is factory-set for three times the load inertia. Therefore, if the load inertia is extremely small, some oscillation may occur. If it does, then lower Cn-04 to 20 or less.

Note 2. After the settings for Cn-11 (number of encoder pulses), Cn-24 (Electronic gear ratio G1 (numerator)), and Cn-25 (Electronic gear ratio G2 (denominator)) have been made, they become effective when the power is turned on again after having been cut off. (Check to see that the LED display has gone off.)

Note 3. Set Cn-11 (number of encoder pulses) according to the number of pulses (resolution) of the encoder. The parameter must be set to 2,048 for an incremental encoder.

Note 4. Refer to the *Computer Monitor Software Instruction Manual (I513)* for OMNUC U-series Servo Drivers for more details on Cn-29 (unit number setting).

Setup Parameters No. 1 (Cn-01)

Item	Bit No.	Factory setting	Setting	Explanation	Setting
Sequence input signal switching	0	0	0	Servo turned ON or OFF by Run command (externally input).	0 =
			1	Servo always ON.	
	1	0	---	No used.	1 = 0
	2	1	0	Enables forward drive prohibit input (POT).	2 =
			1	Permits always-forward drive.	
	3	1	0	Enables reverse drive prohibit input (NOT).	3 =
1			Permits always -reverse drive.		
Sequence output signal switching	4	0	0	Takes TGON/CLIMT signal as motor rotation detection output.	4 =
			1	Takes TGON/CLIMT signal as current limit detection output.	
Processing at time of recovery from momentary stop	5 (see note 1)	1	0	Servo alarm set at time of recovery from momentary stop.	5 =
			1	Servo alarm automatically cleared at time of recovery from momentary stop.	
Abnormal stop	6	1	0	Motor stopped by dynamic brake.	6 =
			1	Motor stopped with free run.	
	7 (see note 2)	1	0	Dynamic brake OFF after motor stopped.	7 =
			1	Dynamic brake ON after motor stopped.	
	8	0	0	Method for stopping when over-travel occurs depends on bit no. 6 setting.	8 =
			1	When over-travel occurs, motor is stopped at the torque set by user parameter Cn-06 (emergency stop torque).	
9	0	0	When over-travel occurs, motor comes to deceleration stop and servo turns OFF.	9 =	
		1	When over-travel occurs, motor comes to deceleration stop and position is locked. (see note 6)		
Deviation counter with Servo OFF	A	0	0	Clear counter for alarms occurring while Servo is OFF.	A =
			1	Do not clear counter for alarms occurring while Servo is OFF.	
P control switch selection	b	1	0	Switch control according to bits C and d.	b =
			1	Do not switch.	
P control switch conditions	d, C (see note 3)	0, 0	0, 0	The torque command value (Cn-0C) is taken as the condition.	C = d =
			0, 1	The speed command value (Cn-0d) is taken as the condition	
			1, 0	The acceleration command value (Cn-0E) is taken as the condition.	
			1, 1	The deviation pulse (Cn-0F) is taken as the condition.	
E	0	---	---	Not used.	E = 0

Item	Bit No.	Factory setting	Setting	Explanation	Setting
Pulse stop switching (HA/LA/V/W Models)	F	0	0	Position Control (Cn-02 bit 2 = 0) Disables the pulse stop input. Internal speed control settings (Cn-02 bit 2 = 1) Command pulses aren't received when PCL and NCL are OFF.	F =
			1	Position Control (Cn-02 bit 2 = 0) Enables the pulse stop input. Internal speed control settings (Cn-02 bit 2 = 1) Command pulses aren't received when PCL and NCL are OFF. (Position control is performed with the internal speed control settings and the pulse-train input.)	

- Note 1.** If power is immediately turned back on after having been cut off, a momentary stop alarm may be generated. If bit no. 5 is set to "1," the alarm will be cleared automatically even if it is generated, and operation will resume.
- Note 2.** If set bit 6 to "1" and bit 8 to "0," the dynamic brake relay will turn OFF after the Servomotor stops, regardless of the setting of bit no. 7.
- Note 3.** With P control switch conditions, a change from PI control to P control is selected.
- Note 4.** Do not change the setting of bits 1 and E of setup parameter no. 1 (Cn-01) when a Servomotor with an incremental encoder is being used.
- Note 5.** These parameters become effective only after power is reset. Confirm that the indicators go out before turning power back on. (Check to see that the LED display has gone off.)
- Note 6.** The position loop will not be effective when stopping in this mode.

Setup Parameters No. 2 (Cn-02)

Item	Bit no.	Factory setting	Setting	Explanation	Setting
Reverse rotation mode	0	0	0	Rotates in CCW direction with a + command. (See note 3.)	0 =
			1	Rotates in CW direction with a + command.	
Origin error mask	1	0	---	No used.	1 = 0
Input command mode (see note 2)	2	0	0	Position control with pulse-train input: CN1-11 and 12 are used as forward and reverse current command inputs (PCL, NCL). In the H/L Models, CN1-15 will be the gain reduction (MING). In the HA/LA/V/W Models, CN1-15 will be the gain reduction (MING) if Cn-01 bit F is set to "0" or the pulse stop input (IPG) if Cn-01 bit F is set to "1."	2 =
			1	[Internal speed control settings] CN1-11 and 12 are used as speed selection command 1 and 2 inputs (SPD1, SPD2). CN1-15 is used as rotation direction command (RDIR).	
Command pulse mode	5, 4, 3	0, 0, 1	0, 0, 0	Feed pulse and Forward/reverse signal	3 = 4 = 5 =
			0, 0, 1	Forward rotation pulse and Reverse rotation pulse	
			0, 1, 0	90° phase difference (A/B phase) signal (1X)	
			0, 1, 1	90° phase difference (A/B phase) signal (2X)	
			1, 0, 0	90° phase difference (A/B phase) signal (4X)	
	6	0	---	Not used	6 = 0
	7	0	---	Not used	7 = 0
	8	0	---	Not used	8 = 0
	9	0	---	Not used	9 = 0
Deviation counter clear	A	1	0	Clears the deviation counter when the signal is high level	A =
			1	Clears the deviation counter on the rising edge of the signal	
Speed integration constant's units (HA/LA/V/W Models)	b	0	0	1 ms	b =
			1	0.01 ms	
Torque command filter time constant (HA/LA/V/W Models)	C	0	0	Primary filter	C =
			1	Secondary filter	
Command pulse logic reversal	d	0	0	Positive logic	d =
			1	Negative logic	
Parameter Unit monitor output lever change	E	0	0	Position deviation monitor set for 1 command.	E =
			1	Position deviation monitor set for 100 command.	
	F	0	---	Not used	F = 0

Note 1. Do not set bit nos. 1, 6 to 9, F of setup parameter no. 2 (Cn-02).

Note 2. These parameters become effective only after power is reset. Confirm that the indicators go out before turning power back on. (Check to see that the LED display has gone off.)

Note 3. Counterclockwise direction viewed from the motor output shaft is CCW.