

TECHNICAL SPECIFICATIONS SUPERVISION

VER. 1.0

FLEXMOD™

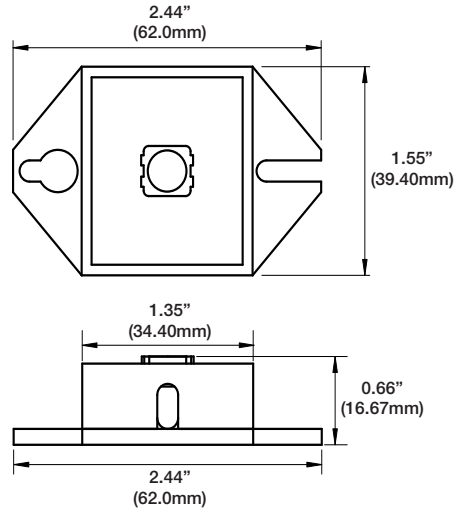

PROJECT:	_____
TYPE:	_____
VOLTAGE:	_____
NOTES:	_____

FLEXMOD™

DESCRIPTION

5 VDC Flexible LED module system for lighting large channel letters, signage and coves.
Open channel letter ready - waterproof and corrosion resistant
Sold by the Foot (2 Modules per foot)

SPECIFICATION FEATURES

Features:

- Easy to install flexible modules-shipped in rolls per requirements
- Water-proof and corrosion resistance
- Modules can be cut to length in the field
- High brightness LED
- IP 68- Wet outdoor location

The Flex-MOD system:

- The Flex-MOD LED's - two modules per foot
- 5V 100 W 120/240 power supply
- Easy installation with adhesive back or screw mount

Energy Efficient:

- 2.4 watts per foot
- With standard 100 watt power supply:
 - 52 modules
 - 4 runs of 13 modules
 - * maximum distance from power supply to first module: 50 feet (15m)

* For 150' (45m) contact factory

Standards:

- UL/cUL (tested to UL48)
- IP68 rated

Module Voltage: 5VDC

LED Type: High power 350mA

Cable Wiring Gauge: #14Awg standard

Optical Data: 120° beam spread

Environmental Specs: (-65°F to 130°F (-53°C to 54°C), 0-100% humidity

Colors: white, warm white, red, orange, amber, blue, and green

Dimensions: 1.35" x 1.55" x 0.04"H
(34.4mm x 39.4mm x 15.33mm)
2.44" Overall Width

ORDERING INFORMATION

FLEXMOD	
FLEX-MOD-W	Cool White
FLEX-MOD-WW	Warm White
FLEX-MOD-R	Red
FLEX-MOD-O	Orange
FLEX-MOD-A	Amber
FLEX-MOD-B	Blue
FLEX-MOD-G	Green
FLEX-MOD-PS100W	Power Supply

ROLL LENGTH
Available by the foot (2 modules per foot)

