

SaVi SHO LIGHT FIXTURE



Specifications:

Application:	Wet / Dry Location
Location Listing:	ETL, CE Certified
IP Rating:	IP 66
Dimensions:	13.0"L x 5.7"W x 9.5"H 330.2mm 133.8mm 239.6mm
Beam Angles:	30 and 45 Degree Angles
Lamps:	12 RGB High Density Array Light Engines
Operating Temperature:	-4° F ~ +104° F / -20° C ~ +40° C
Operating Voltage:	115-240 VAC 50/60 Hz.
Current:	2A Max.
Weight:	21 LBS. / 4.1 Kg.
Available Colors:	Black (Standard), White & Silver - Special Order
Warranty:	2 Years

INSTALLATION MANUAL

Table of Contents

	Page
1.0 General Information	4
2.0 Mounting Instructions.....	5
2.0 Mounting Instructions (cont.)	6
3.0 Introduction to DMX	7
4.0 Cable Connections	7
4.0 Cable Connections (cont.)	8
5.0 DMX / AC Wiring.....	9
6.0 System Operation	10
7.0 Fixture Power / Normal Operation	10
8.0 DMX Addressing	10
8.0 DMX Addressing (cont.)	11
9.0 Test Modes	11
10.0 Termination of DMX Control Run	12
11.0 Trouble Shooting	13
12.0 Warranty	14

1.0 General Information

SaVi Flood Fixture Should Only Be Installed By a Qualified Electrician:

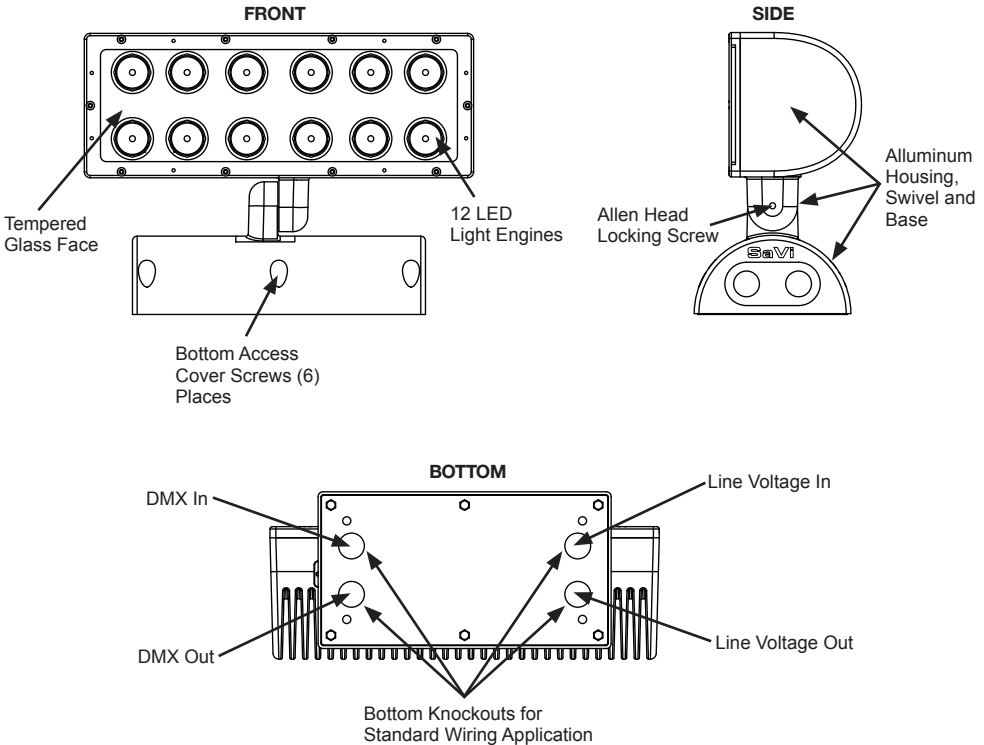

The SaVi SHO fixture uses a total of 12 Light Engines as a source of illumination. This RGB LED technology will display up to 16.7 million color variations. The SaVi SHO fixture is a 115-240 VAC free standing fixture, that is energy efficient and easy to install. Simply connect this fixture to any 115-240 VAC 50/60Hz power source and a Standard DMX512 controller, to provide a wide range of wash and effect lighting. This fixture is constructed of a cast aluminum alloy with a tempered glass face plate. This fixture is completely sealed to keep it free from dust, dirt, water and moisture. The SaVi SHO fixture is articulated between the head and base which allows 180 degrees of angular adjustments to meet most any lighting application. A special effect slot is provided in the fixture face to add a special diffuser to achieve an even wider array of effects. Super Vision International, backs each SaVi SHO fixture with a full two year warranty.

2.0 MOUNTING INSTRUCTIONS

SaVi™

SUPER VISION
INTERNATIONAL

2.0 Mounting Instructions

The SaVi SHO fixture is designed to be mounted in many positions, it can be mounted to a wall or on the floor, it can even be mounted to a pole.

To mount this fixture first pick where you want to run the wiring each fixture come with eight possible knockouts, four on the sides and four on the bottom. After you pick the best wiring method for your application, please knock out the appropriate knockouts and attach 1/2" conduit fittings for wiring.

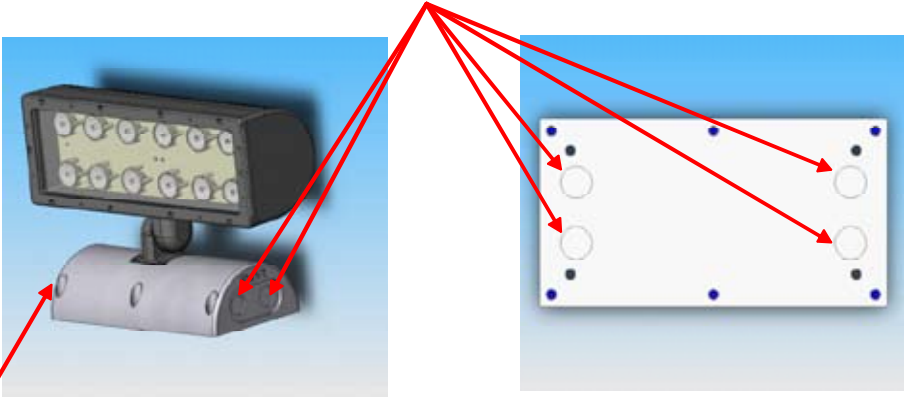

Note: There are two more conduit fitting on the left side

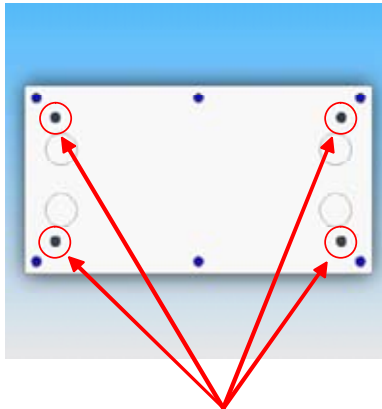

Next you need to mount the base plate, please use the four thru holes located on corners. Use 1/4" hardware to support fixture.

Note: For outdoor mounting all four mounting locations must be sealed with silicon to prevent water from entering into the fixture.

2.0 Mounting Instructions (cont.)

Wall Mount

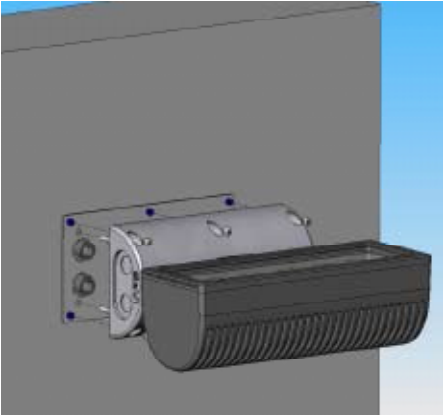

Floor Mount

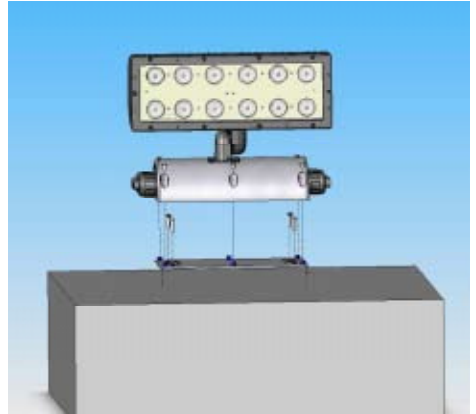

For outdoor mounting, fixture must be mounted at least 6" above the ground to keep the fixture from being exposed to possible water damage.

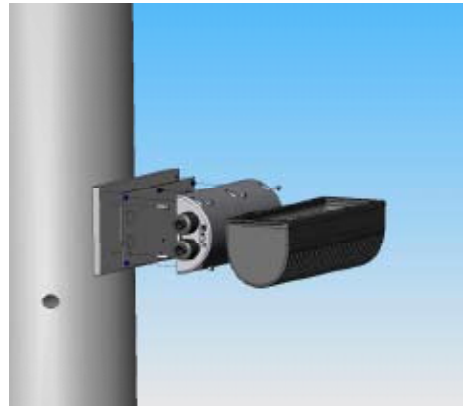
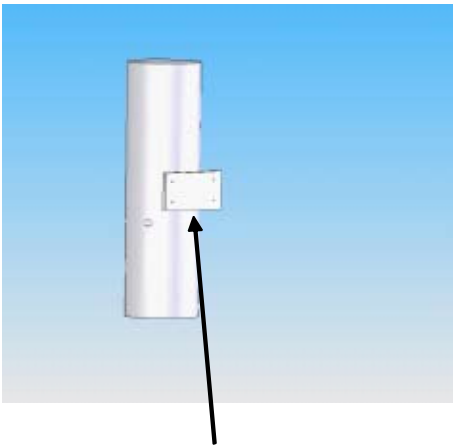

For pole mount, you must first weld a plate to the pole, then you can attach the fixture base plate with 1/4" hardware.

3.0 Introduction to DMX

The DMX512/1990 protocol was introduced in the 1986 by a committee of the United States Institute of Theater Technology (USITT) as a standard method for controlling dimmers for lighting consoles. Since then, the practice has been widely adopted by many manufactures, making it the most universally accepted controlled procedure in the lighting industry today. Super Vision's SaVi SHO fixture brings DMX capabilities to the world. This fixture can be controlled from any standard lighting console or computer with DMX512/1990 compliant output.

Numerous SaVi SHO fixtures can be linked to the same DMX signal cable in a daisy-chain configuration to achieve synchronized operation and/or individual control of every fixture in the system. With the use of an external DMX signal distributors, hundreds of fixtures can be connected and controlled simultaneously. (Ref. Page 4) (For DMX Termination Ref. Page 8)

DMX IN	
Pin 1	Shield
Pin 2	Data (-)
Pin 3	Data (+)

DMX OUT	
Pin 1	Shield
Pin 2	Data (-)
Pin 3	Data (+)

4.0 Cable Connections

DMX512/1990 use a sophisticated, high speed digital communication system. The use of a high quality data cable and professional grade connectors is critical to the systems reliability and dependability. The interconnecting cables must be rated for EIA-485 use and with one or more shielded wire twisted pairs and characteristic impedance near 120 ohms.

Any cable rated by the manufacturer that compiles with the EIA-485 use may be substituted. Examples: Suitable cables include Belden 9841 or 9842, Proplex PC22P or PC224P and Alpha 9817. The SaVi Flood fixture includes two port connectors for the DMX data signal, looking at the rear of the fixture, the left port is "DMX IN" and right port is "DMX OUT". This configuration allows the user to use multiple fixtures simultaneously. (Ref. Page 4)

Note: When using fixtures in an outdoor application, prior to installing DMX cables permanently, it is necessary to slide shrink wrap tubing, which is supplied in kit, over each outdoor connection and shrink down over fittings using heat gun for water and moisture protection.

4.0 Cable Connections (cont.)

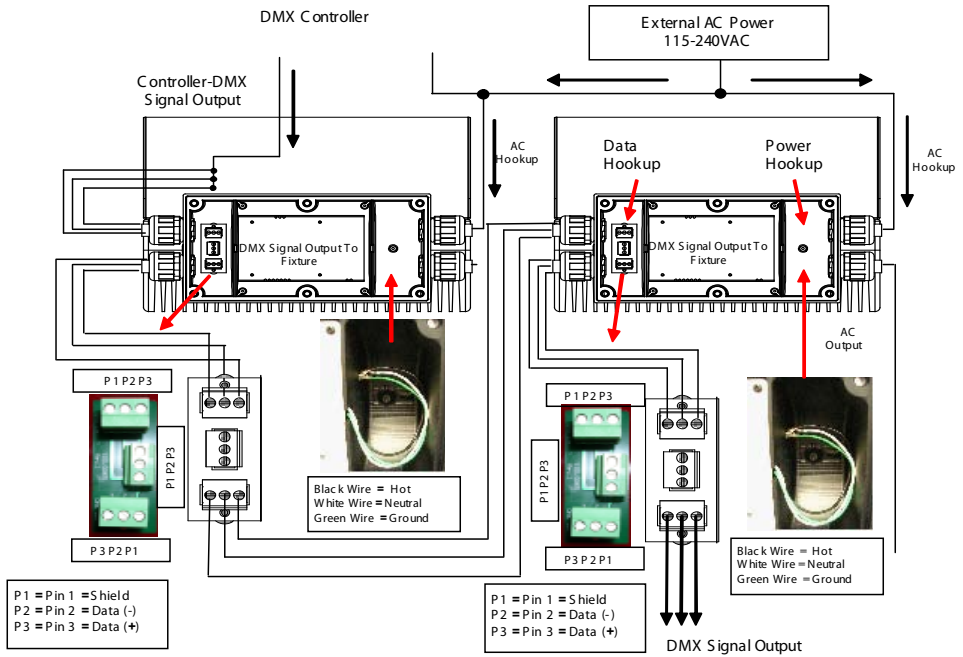

Below each fixture there is a access plate. Remove 6 screws and plate. Inside each of your units there is a Connector Board. Each board has three Data Cable Connectors that are used to link your lighting fixtures together. Each connector has three connection screws, they are P1(S),P2(-), P3(+). Strip back the jacket on the Data Cable approximately 2 inches, inside the cable their are three smaller wires, strip back the wires approximately 1/4 inch on both ends of the cable. These three wires will be used to connect your fixtures together. Insert the three wires into the first fixture P1(S), P2(-) and P3(+) as shown, make sure the Braided Shield wire is always connected to the (P1) connector, tighten down screws firmly. Take the other end of your Data Cable and insert the wires into the second fixture connector as shown. **Note:** It is imperative that the wires you place into the P1, P2 and P3 connector on each fixture are the same wire ends. Continue to connect all units, using the same method.

Note: Any cable rated by the manufacturer that compiles with the EIA-485 may be substituted. Examples: Suitable cables include Belden 9841 or 9842, Proplex PC22P or PC224P and Alpha 9817.

5.0 DMX / AC WIRING

SaVi™



SUPER VISION
INTERNATIONAL

5.0 DMX / AC Wiring

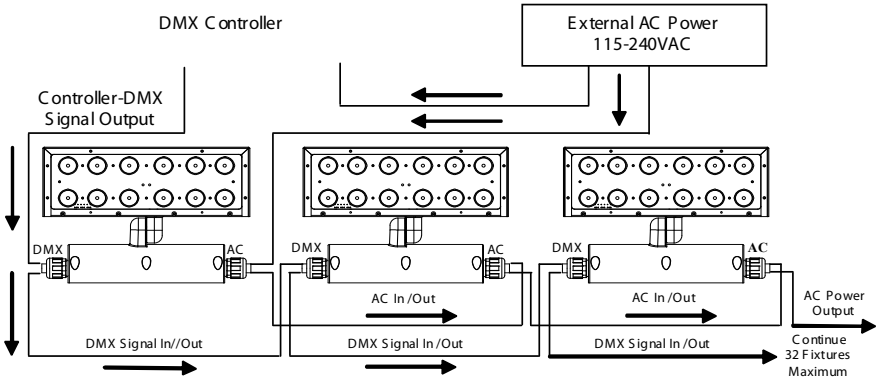

“Main Power” Continuous Row Mounting: 7 Fixtures is the maximum you can daisy chain
“Data” Continuous Row Mounting: 32 Fixtures is maximum you can daisy chain

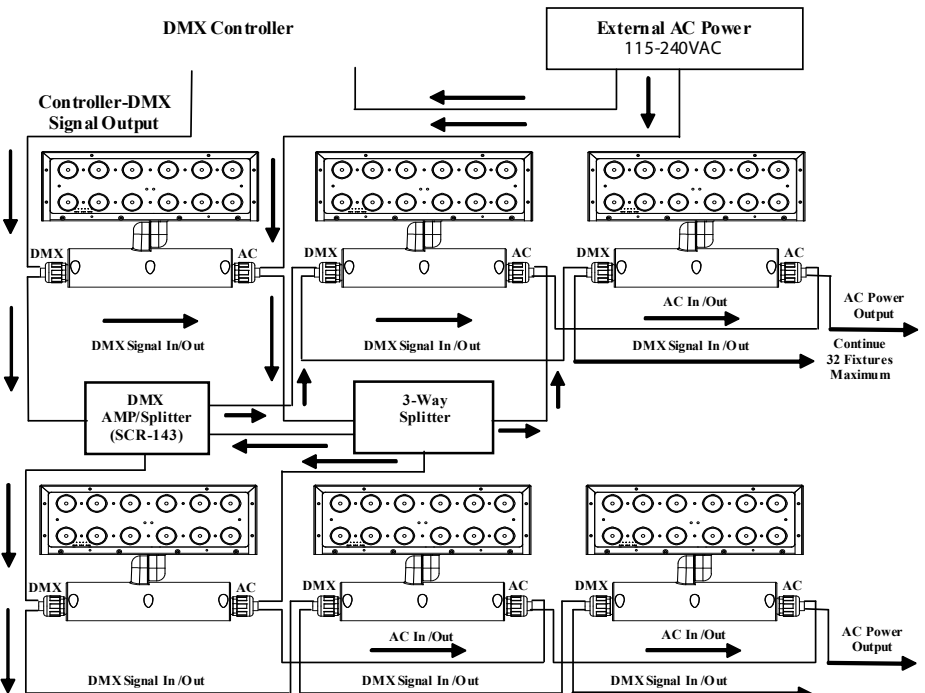

“Main Power” Continuous Row Mounting: 7 Fixtures is the maximum you can daisy chain
“Data” Continuous Row Mounting: 32 Fixtures is maximum you can daisy chain

6.0 System Operation

Each SaVi SHO fixture contains 12 RGB Light Engines, each color consumes 1 channel.

Channel # 1 Controls Red

Channel # 2 Controls Green

Channel # 3 Controls Blue

The use of a DMX terminator is highly recommended with long DMX cable runs to prevent reflections along the data chain. (Ref. Page 8)

7.0 Fixture Power Up / Normal Operation

If power is supplied to your SaVi SHO fixture when there is no DMX signal present no light will illuminate from the fixture. Once the DMX signal is present, the light will follow intensity commands as prescribed from the DMX signal source. Each SaVi SHO fixture will respond to only one DMX address. The SaVi SHO fixture addressing requires that the power be cycled "On/Off " before a new DMX address can be recognized.

8.0 DMX Addressing

To select DMX addressing on your SaVi SHO fixture. Look at the left rear of your fixture, there is a small rectangular cover, remove the covers and there is three rotary switch's that are used to select the address for this particular fixture.

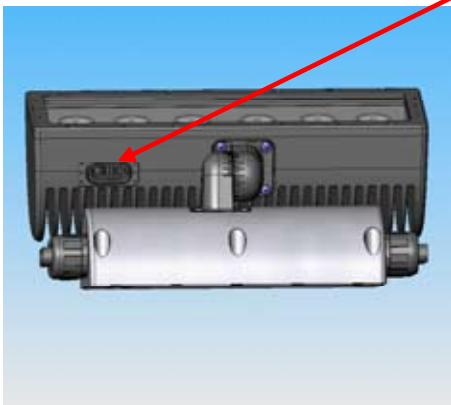

8.0 DMX ADDRESSING (cont.)

SaVi™

SUPER VISION
INTERNATIONAL

8.0 DMX Addressing (cont.)

To set an address there is a multiplier associated with each switch, the left right switch is multiplied by a factor of 1, the middle switch is multiplied by a factor of 10, and the left switch is multiplied by a factor of 100. The switch values are then added together, to form the complete base address. For example if you want to set the fixture to DMX channel 1

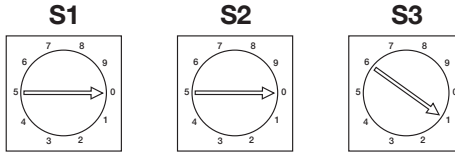

You can set the base address between 1 and 509 (Note, the base address plus the two

9.0 Test Modes

To test the fixture without using DMX, set the Address Switch's to the following settings.

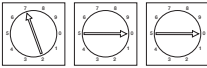

S1	S2	S3	
x100	x10	x1	
7	0	0	Slow Color Fade - All Colors
7	0	1	Fast Color Snap - All Colors
7	0	2	White - Static
7	0	3	Blue - Static
7	0	4	Green - Static
7	0	5	Red - Static
7	0	6	Yellow - Static
7	0	7	Purple - Static
7	0	8	Cyan - Static
7	0	9	Fast Fade - Red, White, Blue

10.0 Termination of DMX Control Run

Why is it necessary to terminate the end of a DMX512 control run? In Recommended Practice for DMX512 by Adam Bennette, Mr. Bennette states “Incorrect or missing termination is probably the single most common reason for faulty DMX512 systems.”

Reflections: DMX512 signals have electrical components in the Radio Frequency (RF) range. Cables carrying radio frequencies are called Transmission Lines and have a special set of rules and formulas that describe their behavior. One of these rules describes what happens to a signal traveling down the cable (at over half the speed of light) when it hits the end of the cable. No, the cable doesn’t bulge or explode. Instead a percentage of the signal is “reflected” back up the cable. The way to prevent this reflected energy is to absorb it. To absorb the maximum amount of energy, a resistor which matches the “characteristic impedance” of the cable is placed across the data line. The DMX512 specification states the cable should have a characteristic impedance of 120 ohms (although most DMX512 technicians agree a value between 100 and 120 ohms is satisfactory). A value of 120 ohms is usually specified for proper DMX512 termination.

Why are reflections a problem? The signals travel down the cable at roughly 60% of the speed of light. Although fast, this is not instantaneous. The DMX512 data is digital. Each digit is placed on the line for only 4 millionths of a second (abbreviated 4uS). The receiving device looks at the value of the digit in the center of the 4uS. That is 2uS after the digit is placed on the line. In 2uS a signal can travel down and back about 590 feet of cable. If a device is sitting on a cable such that it receives the reflected signal as well as the initial signal, it sees two numbers at once. It gets confused! There has been DMX512 problems, which were corrected by termination, on cables much shorter than 590 feet. Although it can easily replicated, there are DMX512 problems with cable lengths over 500 feet. The following are some possible explanations:

1. The cable they were using was “slow” with the signals traveling at much less than 60% of the speed of light.
2. Reflections can occur at both ends of the cable. Perhaps the delayed signal had been reflected up and down the line several times causing a 2uS delay on shorter cables. A weak signal from the console may aggravate this problem. The problem was not caused by reflections, but by noise or signal distortion. The low resistance of the terminator helps to clean up the signal. (See Below)

Cable Capacitance and Inductance: In looking at DMX512 signals on the oscilloscope I’ve noticed signal distortion on relatively short lines. Some distortion is caused by the fact that all cables have capacitance and inductance. This causes “ringing” (oscillation at the beginning or end of a digit) and rounding of the edges of the digit. Although any low value resistor across the end of the line will lower the effect of cable capacitance and inductance, using the proper termination resistance is differently recommended.

Noise: Low impedance cabling systems pick up less electrical noise than high impedance systems. By adding the proper termination, the susceptibility of the system to noise is reduced.

DMX Terminator: All DMX lines must be correctly terminated if reliable operation is to be obtained. Make sure that only the last item in the chain has a terminator connector on it. If the last item (**Farthest from data source**) does not have a terminator, then one is needed. To make one you will need the following parts :

- 1 Male 5 Pin XLR or Male 3 pin XLR connector.
- 1 120 ohm 0.5W resistor.

3 pin XLR connector, with 120 Ohm resistor soldered between pins #2 and #3.



11.0 Troubleshooting

The fixture does not operate:

- Make sure the fixture is wired properly. Check for the application of both the correct voltage as well as a DMX signal.

All LED's are lit, their is no response to any DMX command:

- Check for DMX Signal between the Control Desk and the fixture. Once this is verified, check the fixture's DMX address. Cycle the power to the fixture to insure that it is recognizing the address that is currently on the digital display.

The fixture will not respond to any given command:

- Check for DMX signal between the Control Desk and the fixture. Once this is verified, check the fixture's DMX address. Cycle the power to the fixture to insure that the address is recognized and is currently on the digital display.

One color responds to a DMX Signal, but the other colors will not respond to a given command from the Control Desk:

- Check the fixture by removing the DMX cable from the fixture, and cycle the power "On/Off ". If the failure persists, check the patch in the DMX Control Desk for the proper channel assignments. Re-address the fixture to another address, re-try the test. If the fixture is still not working correctly check the DMX cable for missing signals or broken conductors. Once the root trouble is isolated, re-address the fixture to the original setting and re-try the test.

All LED's are lit, the output appears to be dim:

- Check the DMX command levels for all three channels controlling the fixture in question. Check the Grand Master fader of the DMX Control Desk. Bring these levels to full (255, or 100%) Verify that the power supplied to the fixture is not being supplied by a dimmable circuit, and that the full 115-240 VAC is present, at the SaVi SHO fixture power supply.

SuperVision International, maintains a full staff of highly qualified technicians who are available to assist you with any technical issue that may arise from the use of the SaVi SHO fixture.

LIMITED WARRANTY

Super Vision International, Inc. warrants its products, excluding lamps, to be free from defects in material and/or workmanship, under normal condition, use and service, for a period of two (2) years from the original invoice date (Five (5) Years for Red, Amber and Orange FlexLED and Border Light LED products and one (1) Year for Non-UL Listed Power Supplies). If proof of purchase is provided, Super Vision will warranty the product for two (2) years from date of the purchase (Five (5) Years for Red, Amber and Orange FlexLED and Border Light products and one (1) Year for Non-UL Listed Power Supplies).

TERMS AND CONDITIONS:

This warranty only applies when Super Vision products are properly wired and installed together as a system; and operated within the electrical values shown on the Super Vision specification sheets; used in lighting equipment designed and approved for the application and environmental conditions (temperature, humidity) within the normal specified operating range of the system. This warranty does not apply to any abnormal use in violation of any applicable standard, code or instructions for use in installations including those contained in the latest National Electrical Code (NEC), the Standards for Safety of Underwriters Laboratory, Inc. (UL), Standards for the American National Standards Institute (ANSI), in Canada, the Canadian Standards Association (CSA), Europe (CE), Australia (C-Tick). This warranty will not apply in the event of conditions demonstrating abnormal use or stress, including under/over voltage conditions, excessive switching cycles, excessive operating hours, alterations, accident, theft, misuse, abuse and damaged caused by negligent installation, improper maintenance or where adequate care has not been taken to prevent damage to the lighting system. Replacement of Super Vision components with any other manufacturer will void the entire warranty.

WARRANTY SERVICE CLAIMS:

Super Vision must issue a Return Material Authorization (RMA) number for all requests for warranty review. To expedite service, please contact Super Vision Customer Representative: 1-407-857-9900. If you are unsure whether a situation exists that is covered by this warranty, please contact Super Vision Customer Service for assistance. In the event of a defect in material or workmanship during the warranty period, Super Vision will repair or replace (at its own discretion) its products under the conditions of the warranty.

RETURN OF DEFECTIVE PRODUCT:

After contacting Super Vision and receiving the RMA#, the purchaser / user shall promptly return the product after receiving instructions regarding if, when and where to ship product. Product must be returned within 30 days of receiving RMA#, Shipping box must be clearly marked with RMA#. Failure to follow this procedure shall void this warranty. Super Vision will cover expenses for material but will not cover shipping costs. Products returned without an RMA# will be refused and returned to sender at the senders expense.

REPLACEMENT OF PRODUCT, LIMITS OF LIABILITY:

The foregoing shall constitute the exclusive remedy of the purchaser and the sole liability of Super Vision International regarding its products and component warranty. **NO WARRANTY OF MERCHANTABILITY OR FITNESS FOR A PARTICULAR PURPOSE IS MADE OR IS TO BE IMPLIED.** In no event shall Super Vision be liable for any other costs or damages including labor charges, lost profits or revenues, incidental, special or consequential damages. Total liability shall not exceed the total extended purchase price for the product. Super Vision reserves the right to examine all failed Super Vision products and components to determine the cause of failure and patterns of usage and reserves the right to be the sole judge as to whether any product or component is defective and covered under this warranty.

March 30, 2005 Rev. 0



SUPER | VISION
INTERNATIONAL

SaViTM
architectural LED lighting