

LED-*drive* for the Lighting Industry

Standard and special solutions

Electronic Power Supply for
POWER-LEDs from 350 – 1000 mA output current

Product Overview



LED – Power Supply Technology

Optimal solutions for all applications

New installation ideas in lighting technology engineering call for modern and customized power supplies in the range of LED applications.

The increasing number of types in lighting technology require power supplies that can be easily and effortlessly integrated in overall solutions. The demand for custom-tailored solutions is increasing constantly. For this reason the power supply has many important functions in many ranges of the LED technology, such as DALI and DMX interfaces as well as RGB control (three-channel devices):

- Safe connection of the LED to the mains supply
- Interface between mains and LED application via control inputs
- Interconnection of the control inputs via active interfaces (e.g. analog input 1-10V)
- Adjustment control of the dimming input via semiconductor components (PWM)
- Control of the luminaire temperature via external sensors (PTC connection)

All ranges of lighting technology provide examples for these functions:

- In the range of illumination technique, the light intensity can be controlled via LED luminaires and LED objects.
- In the range of lighting equipment for shows and stages, LED-drive provides for secure and reliable power supplies, even under extreme conditions.
- Other applications are e.g. automotive engineering, traffic light installations, digital image processing as well as medical engineering.

Being a very flexible power supply system, the various device types of LED-drive allow for very different applications. Schiederwerk meets this challenge by increasingly developing devices in customer specific design.

This overview is presenting the Schiederwerk product "LED-drive" and its use in the whole lighting technology.

Page	Power Supply Devices "LED-drive"
3	Applications and device types
4	Features
5	AC design in one-channel technology
6	Applications and dimensions
7	Basic circuit diagram and technical data
8	AC design in three-channel technology and technical data
9	Dimensions and basic circuit diagram
10	Range of products and order data of the AC devices
11	DC design in one-channel technology (DC converter)
12	Dimensions
13	Basic circuit diagram and technical data
14	Range of products and order data of the DC devices

Electronic Power Supply LED-drive

Applications and device types

LED-drive – the ideal solution for

- Power LEDs, e.g. *LUXEON* (LUMILEDS)
- Standard LEDs (luminescence diodes)
- LED SMD modules, e.g. INSTA, OSRAM

The LED-drive devices are primarily intended to be used for the power supply of Power LEDs with output currents of 350, 700 or 1000 mA.

Applications in the Power LED range normally require a constant current of 350 mA for Luxeon I, 700 mA for Luxeon III and V or 1000 mA for Luxeon III. They can be dimmed via a pulse width modulation (PWM) of 5-100 % and a control (1-10 V DC).

For the time being, the LED-drive devices are up to following standards:

1. Housing devices in AC-design, without dimming function, in 350, 700 or 1000 mA version
2. Housing devices in AC-design, with output voltage DC 48V (high voltage version) and with dimming function, in 350 mA for connecting up to 12 LEDs (1W)
3. Housing devices in AC-design, with output voltage DC 28V and dimming function in 350, 700 or 1000 mA version for connecting up to 7 LEDs (1W)
4. Housing devices in AC-design with three-channel output and individual dimming function for RGB-applications (3x350 mA) for connecting up to 4 LEDs (1W) per channel
5. Housing devices in DC-design, 12-30 V, with dimming function, in 350, 700 or 1000 mA version
6. OPEN-Frame devices (PCB type), in DC-design, in 350, 700 or 1000 mA version

Additional device types are both being scheduled and developed.

Please note:

For standard LEDs and SMD modules, a modified version with a constant voltage output such as DC 24 V is available.

Another possible application for Luxeon-LEDs is to wire a DC converter (page 11) with a central feeder (e.g. transformer with suitable rectifier circuit DC 12-30V). Due to smaller dimensions, this measure allows for minimizing the space required in the application.

Features

- Optimal adaption to *Luxeon* Power light sources
- Efficient energy saving via power electronics
- High efficiency resulting in reduction of the power consumption
- Current regulation providing uniform light efficiency by means of a built-in PWM dimming module for low-loss brightness control
- Dimming function realised by connecting an external potentiometer (conventional or electronic) or an analogue input 1-10 V DC
- Dimming does not require changes of the light temperature
- Designed for the use of up to 12 Luxeon I (1W) in parallel connection
- Multichannel type (three-channel), equipped with individual control (analog input DC 1-10V) for RGB use and colour control
- Input for temperature control available
- Long durability (>50.000 h)
- Integrated short-circuit and overload protection
- Safety provided by extra-low voltage (SELV)
- High dielectric strength of 3,75 KV between L, N and secondary (according to DIN EN 61046) is complied with
- Compact constructional structure (AC-device:103x67x30 mm/ DC-device: 49x48x28 mm)
- Wide range of operating temperature
- Potted devices for outdoor applications available
- Wide range of products, customer specific applications are feasible

LED-drive in AC-design Product description and device function

The LED-drive-35 LR/ -70 LR/ -100 LR are switchable devices without dimming function which are used for the power supply of Power LEDs.

The LED-drive-35 RU/ -70 RU/ -100 RU are switchable devices which are used both for the power supply and for the brightness control of Power LEDs.



Via the feeder clamps, the LED-drive is directly connected to the 230 V mains supply. Irrespective of the number of Power LEDs, the output current is being re-adjusted to a constant value. Nevertheless, the specified maximum output power must not be exceeded. Depending on their type, the devices supply the required constant current at the output. Compliance with the guidelines for SELV current circuits is ensured. The device is short-circuit-proof and resistant against overtemperatures, no-load and overload conditions.

The brightness control of the LEDs works with an integrated PWM module with a 1-10 V control input. These control inputs may alternatively be operated with an electronic potentiometer (1-10 V), a conventional potentiometer or a DC control voltage 1-10 V.

The devices may work with e.g. following number of Power LEDs (in each case with simultaneous consideration of the maximum output power of the particular device, in case of nominal values: maximum power and maximum brightness of LEDs). Another factor to be considered is the LED type (light colour):

- LED-drive-35 (350 mA): 1...7 x 1 W (Luxeon I) in series
- LED-drive-70 (700 mA): 1...3 x 5 W (Luxeon V) in series
- LED-drive-100 (1000 mA): 1... 6 x 3 W (Luxeon III) in series
- LED-drive-70 (700 mA): 1...6 x 3 W (Luxeon III) in series

The devices are equipped with a separate input designed for a temperature control. A NTC resistor (e.g. NTC 47 k Ω , Siemens B 57621-C 473-J62 or the like) may be connected. In case the specified temperature is exceeded, the device adjusts the current or switches off in order to prevent damages. For this purpose, the NTC resistor is being connected to clamps 4 and 6.

Application notice

Following numbers of *Luxeon* may be operated with the devices (considering the maximum output power of the particular device). The number of *Luxeon* used depends as well of the used LEDs (light colours):

- | | |
|-------------------------------------|---|
| 1. LED-drive-35 (HV-type) (350 mA): | 1...12 x 1 W (Luxeon I) in series |
| 2. LED-drive-35 (350 mA): | 1... 7 x 1 W (Luxeon I) in series |
| 3. LED-drive-70 (700 mA): | 1... 3 x 5 W (Luxeon V) in series |
| 4. LED-drive-100 (1000 mA): | 1... 6 x 3 W (Luxeon III) in series |
| 5. LED-drive-70 (700 mA): | 1... 6 x 3 W (Luxeon III) in series |
| 6. LED-drive-3x35 (3x350 mA): | 1... 4 x 1 W (Luxeon I) in series per channel |

Please note:

Given that the wiring is adequate, it is feasible to operate up to 14 *Luxeon* (1W, 350 mA) with the LED-drive-70 (700 mA). For this purpose, 2 lines may be connected in parallel with 7 *Luxeon* I in series at a time.

Example of an application with Luxeon Power LEDs:

1. LED-drive-35 RU HV: connection of up to 12 pcs. type Luxeon Emitter, 350 mA, colour white
2. LED-drive-35 RU: connection of up to 7 pcs. type Luxeon Emitter, 350 mA, colour white
3. LED-drive-70 RU: connection of up to 1 x Luxeon Line, 700 mA, colour white
4. LED-drive-70 RU: connection of up to 1 x Luxeon Ring-Up (12-er) / 2 x Luxeon Ring-Up (six), 700 mA
5. LED-drive-3x35 UR: connection of up to 4 pcs. per channel, type Luxeon Emitter, 350 mA, colour white

Dimensions

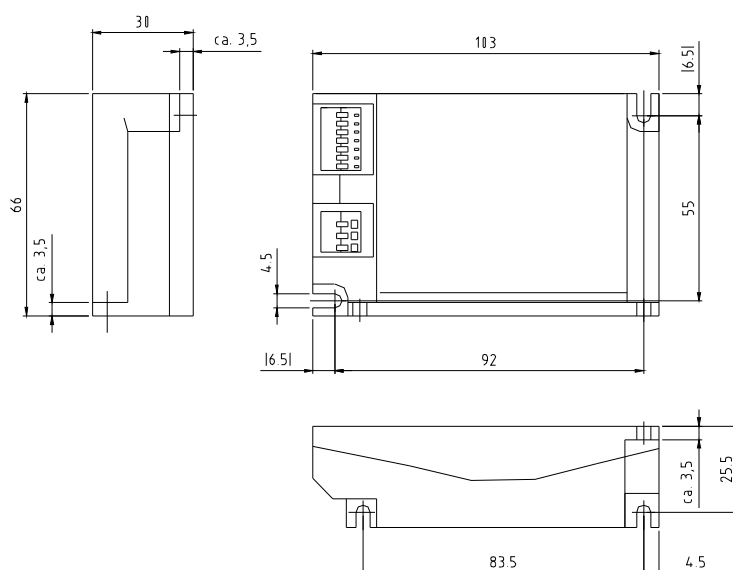

Basic Circuit Diagram

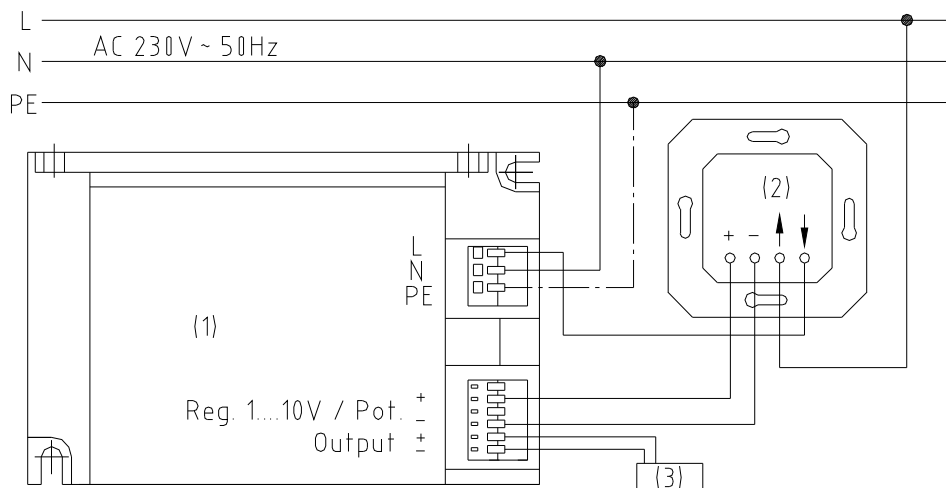

Technical Data

Nominal voltage:	230 V AC, $\pm 10\%$ 50/60 Hz 220 V DC, $\pm 10\%$
Power range:	0 – 9 W with 350 mA 0 – 17 W with 700 mA 0 – 17 W with 1000 mA
No-load voltage U_0 :	28 V DC $\pm 10\%$
Output current:	350 mA + 5% / - 10% (LED-drive-35) 700 mA + 5% / - 10% (LED-drive-70) 1000 mA + 5% / - 10% (LED-drive-100)
Constant current in the output voltage range:	2V – 25V 2V – 45V (HV type) with 1000 mA (2V-20V)
Length of secondary line:	max. 15 m
Protection class	I
Ambient temperature:	0-50 °C (350 mA), 0-45 °C (700 mA)
Housing temperature T_c :	max. 75 °C
Terminal cross section:	min. 0,5 mm ² max. 1,5 mm ²
Dimming range PWM 1-10 V DC	0...100%
Control voltage	0 - 0,7V Lamp OFF 1-10V Dimming 5 % to 100 %
Max. control current:	1 mA (source)
Temperature control input (connection clamps 4 and 6)	external NTC *
Standards complied with	EN 55015 / EN 61547 / EN 61347-2-2
Dimensions (LxBxH) / mm:	103 x 66 x 30

* NTC 47k Ω , e. g. Siemens B 57621-C 473-J62 or the like

LED-drive in AC design (three-channel-device)

For colour mixtures (RGB control), **three-channel devices** with 3 x 350mA output current and dimming function are available. The brightness control works with an integrated PWM module with a 1-10V control input. These control inputs may alternatively be operated with an electronic potentiometer (1-10 V), a conventional potentiometer (10kOhm) or a DC control voltage 1-10 V. This power supply enables you to continuously adjust your individual colour mixture. In addition, the device is equipped with an internal thermic protection which shuts off power when temperature is becoming too high.

The electronics is being mounted in a potted housing. The connection is made via 2 wires (mains and control cable). The device is suited for outdoor applications.



Technical Data of the three-channel device

Nominal voltage	230 V AC, $\pm 10\%$ 50/60 Hz 220 V DC, $\pm 10\%$
Number of LEDs per channel	1 ... 4 x 1W (Luxeon I) in series (350 mA)
No-load voltage U_0 per channel	28 V $\pm 10\%$
Output current per channel	350 mA + 5% / - 10%
Constant current in the output voltage range:	2 V - 27 V
Length of secondary line:	max. 15 m
Protection class:	I
Maximum ambient temperature	40 °C
Maximum control current per channel	1 mA (source)
Dimming range per channel (PWM)	0-100 %
Control voltage	0 - 0,7V Lamp OFF 1-10V Dimming 5 % to 100 %
Connecting cables	Mains cable: UL 3xAWG 18 (H05VV-F/SJT) Control cable: round non-metallic sheathed cable UL 7xAWG 22 AWM style 2464
Standards complied with:	EN 55015 / EN 61547 / EN 61347-2-2
Dimensions (LxBxH) / mm:	103 x 66 x 30

Dimensions

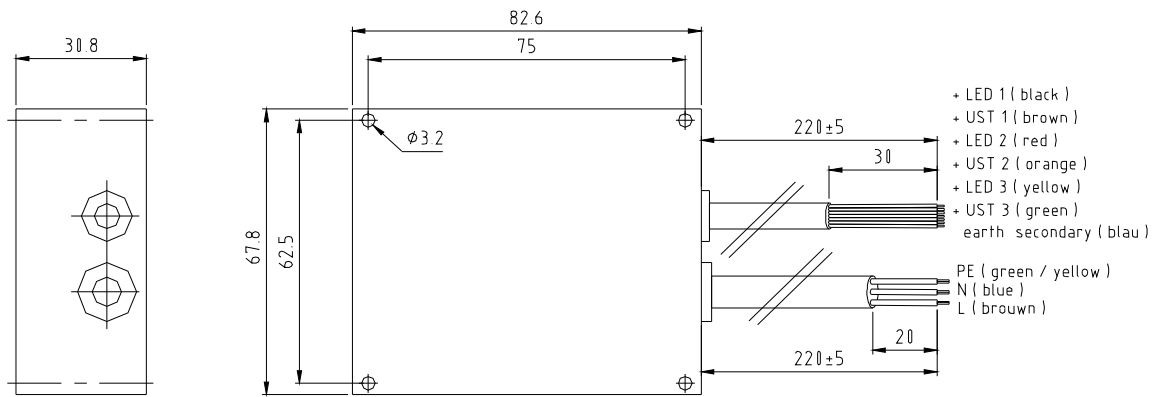

Basic circuit diagram

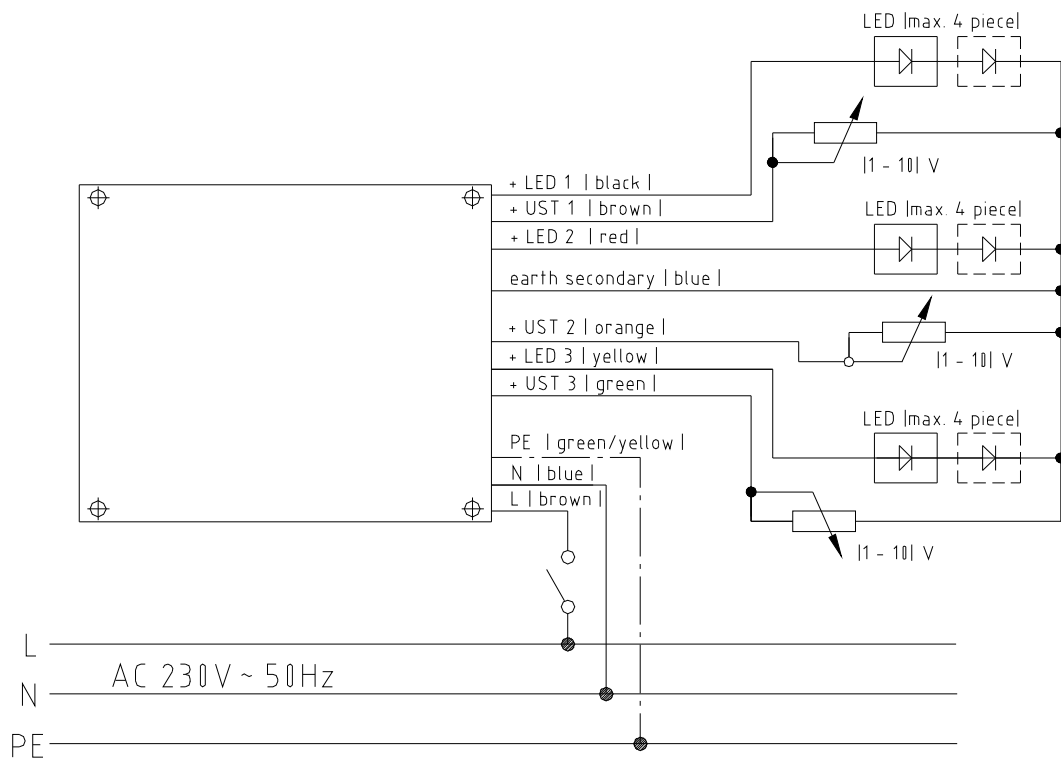

LED-drive in AC-design

Range of products and order data

AC-Housing devices	Output current	Article number
Without dimming function:		
LED <i>drive</i> -35 RL	350 mA	32 648 1000
LED <i>drive</i> -70 RL	700 mA	32 648 1700
LED <i>drive</i> -100 RL	1000 mA	32 648 1100
With dimming function: U _{out} = DC 28V for connection of max. 7 LEDs (1W) Potentiometer (mechanical/ electronic) or Dim input 1-10V DC		
LED <i>drive</i> -35 RU	350 mA	32 649 1000
LED <i>drive</i> -70 RU	700 mA	32 649 1700
LED <i>drive</i> -100 RU	1000 mA	32 649 1100
With dimming function: U _{out} = DC 48V for connection of max. 12 LEDs (1W) Potentiometer (mechanical/ electronic) or Dim input 1-10V DC		
LED-drive-35 RU HV	350 mA	32 644 1000
Three-channel-design, suitable for dimming: (e.g. for RGB-control)		
LED <i>drive</i> -3x35 UR	350 mA	32 820 1000

LED-drive in DC-design (DC converter)

The LED-drive-35/ -70 DC 24 are switchable devices with dimming function which are used for the power supply of Power LEDs with nominal currents of 350/700 mA..

The DC converter has an input voltage range of DC 12-30 V and supplies a maximum output of $U_{out}=0,8 \times U_{in}$.

Two types of devices suitable for dimming are available:

- control input 1-10 V DC:

The brightness control of the LEDs works with the an integrated PWM module with a 1-10V control input. These control inputs may alternatively be operated with an electronic potentiometer (1-10 V), a conventional potentiometer or a DC control voltage 1-10 V.

- control input external PWM signal (rectangle):

The brightness control works by feeding an external rectangular PWM signal (40 Hz...10 KHz, 3,5...10 V) to the control input +Ust.

The LED-drive in DC design (12-30V) is available both as housing device (closed with connecting leads) and as open-frame assembly (PCB version) (see range of products and order data).

The connection is made either via 4 lines or with clamps on the PCB.



Dimensions

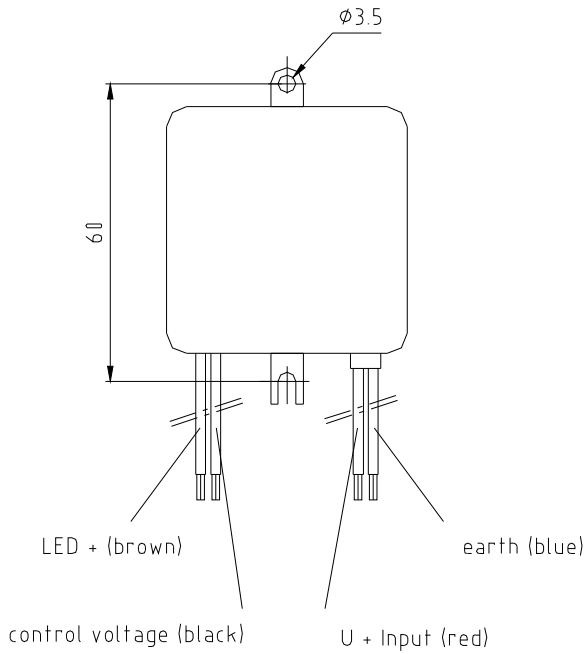

Closed housing with connecting leads

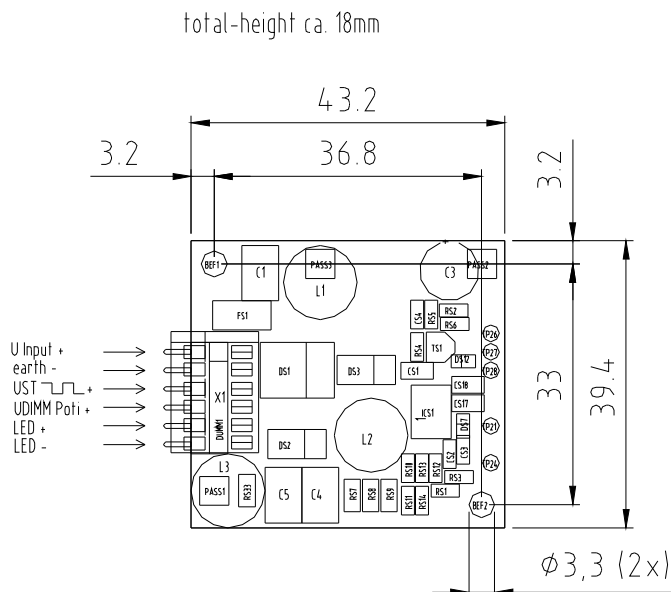

Pin assignment of the DC converter (LED-drive-... DC 24, PCB version)

Basic Circuit Diagram (example)

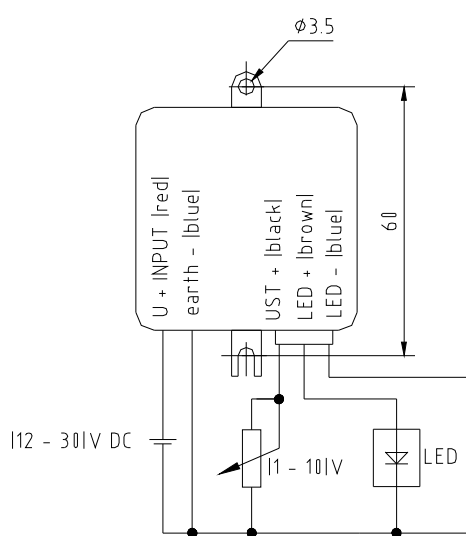

Connecting diagram LED *drive-35 / 70* DC

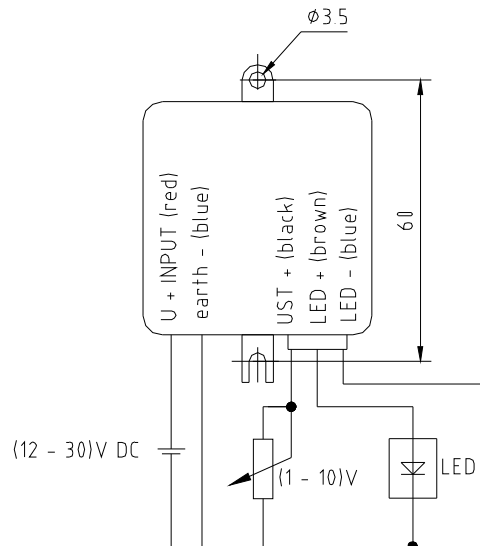

Connecting diagram LED *drive - 100* DC

Technical data

Input voltage:	12 ... 30 V DC
Power range:	0 – 9 W with 350 mA 0 – 19 W with 700 mA
No-load voltage	28,5 V ± 10%
Output voltage:	0,8 x U _{in}
Output current::	350 mA (LED- <i>drive-35</i>) 700 mA (LED- <i>drive-70</i>)
Constant current in the output voltage range:	2 V - 27 V
Length of secondary line:	max. 15 m
Protection class:	III
Number of LEDs with maximum input voltage 30V (example)	1...7 x 1 W (Luxeon I) in series (350 mA) 1...3 x 5 W (Luxeon V) in series (700 mA) 1...6 x 3 W (Luxeon III) in series (1000 mA) 1...6 x 3 W (Luxeon III) in series (700 mA)
Ambient temperature:	0 - 45 °C
Control voltage	0 - 0,7V Lamp OFF 1-10V Dimming 5 % to 100 %
Max. control current:	1 mA (source)
Dimming range PWM rectangle * Dimming range 1-10 V DC **	0 – 100 %
Dimensions (LxBxH) / mm:	49 x 48 x 28 (housing, closed) 43x40x18 (PCB version)

* External PWM signal (rectangle) required (40Hz ... 10kHz), 3,5 ... 10V

** External Dim Input (Ust 1-10V DC) required

LED-drive in DC-design

Range of products and order data

DC-Housing devices	Output current and colour coding on PCB	Article Number
With dimming function: External potentiometer (mechanical / electronic) or Dim input 1-10V DC (closed housing with connecting leads)		
LED <i>drive</i> -35 DC 24 RU	350 mA (yellow)	32 805 1352
LED <i>drive</i> -70 DC 24 RU	700 mA (red)	32 805 1020
LED <i>drive</i> -100 DC 24 RU *	1000 mA (blue)	planned

DC-PCB version	Output current and colour coding on PCB	Article Number
With dimming function: External potentiometer (mechanical / electronic) or Dim input 1-10V DC		
LED <i>drive</i> -35 DC 24 D	350 mA (yellow)	32 810 1350
LED <i>drive</i> -70 DC 24 D	700 mA (red)	32 810 1000
LED <i>drive</i> -100 DC 24 D *	1000 mA (blue)	32 811 1000
With dimming function: External PWM-signal (rectangle)		
LED <i>drive</i> -35 DC 24	350 mA (yellow)	32 800 1350
LED <i>drive</i> -70 DC 24	700 mA (red)	32 800 1000

Subject to technical changes without prior notice.

06/05