

QUADRATURE CLOCK CONVERTER

FEATURES:

- x1, x2 and x4 resolution
- Programmable output pulse width (200ns to 140µs)
- Excellent regulation of output pulse width
- TTL and low voltage CMOS compatible I/Os
- +3V to +5.5V operation (VDD - VSS)
- LS7183, LS7184 (DIP);
LS7183-S, LS7184-S (SOIC) - See Figure 1

DESCRIPTION:

The LS7183 and LS7184 are CMOS quadrature clock converters. Quadrature clocks derived from optical or magnetic encoders, when applied to the A and B inputs of the LS7183/LS7184, are converted to strings of Up Clocks and Down Clocks (LS7183) or to a Clock and an Up/Down direction control (LS7184). These outputs can be interfaced directly with standard Up/Down counters for direction and position sensing of the encoder.

INPUT/OUTPUT DESCRIPTION:

RBIAS (Pin 1)

Input for external component connection. A resistor connected between this input and Vss adjusts the output clock pulse width (Tow).

VDD (Pin 2)

Supply Voltage positive terminal.

Vss (Pin 3)

Supply Voltage negative terminal.

A, B (Pin 4, Pin 5)

Quadrature Clock inputs A and B. Directional output pulses are generated from the A and B clocks according to Fig. 2. A and B inputs have built-in immunity for noise signals less than 50ns duration (Validation delay, T_{VD}). The A and B inputs are inhibited during the occurrence of a directional output clock (UPCK or DNCK), so that spurious clocks resulting from encoder dither are rejected.

MODE (Pin 6)

MODE is a 3-state input to select resolution x1, x2 or x4. The input quadrature clock rate is multiplied by factors of 1, 2 and 4 in x1, x2 and x4 mode respectively in producing the output UP/DN clocks (See Fig. 2). x1, x2 and x4 modes selected by the MODE input logic levels are as follows:

- Mode = 0 : x1 selected
- Mode = 1 : x2 selected
- Mode = Float : x4 selected

PIN ASSIGNMENT - TOP VIEW

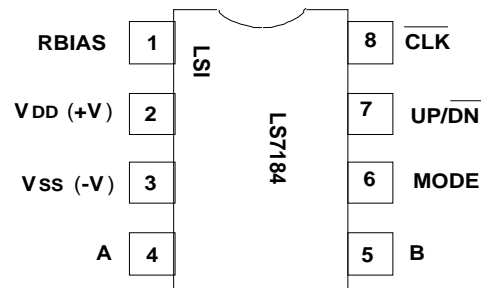
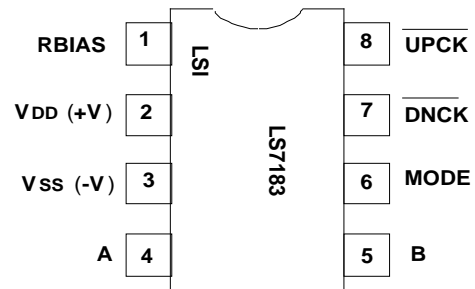

FIGURE 1

LS7183 - $\overline{\text{DNCK}}$ (Pin 7)

In LS7183, this is the DOWN Clock Output. This output consists of low-going pulses generated when A input lags the B input.

LS7184 - $\overline{\text{UP/DN}}$ (Pin 7)

In LS7184, this is the count direction indication output. When A input leads the B input, the UP/DN output goes high indicating that the count direction is UP. When A input lags the B input, UP/DN output goes low, indicating that the count direction is DOWN.

LS7183 - $\overline{\text{UPCK}}$ (Pin 8)

In LS7183, this is the UP Clock output. This output consists of low-going pulses generated when A input leads the B input.

LS7184 - $\overline{\text{CLK}}$ (Pin 8)

In LS7184, this is the combined UP Clock and DOWN Clock output. The count direction at any instant is indicated by the UP/DN output (Pin 7).

NOTE: For the LS7184, the timing of $\overline{\text{CLK}}$ and $\overline{\text{UP/DN}}$ requires that the counter interfacing with LS7184 counts on the rising edge of the CLK pulses.

ABSOLUTE MAXIMUM RATINGS:

PARAMETER	SYMBOL	VALUE	UNITS
DC Supply Voltage	$V_{DD} - V_{SS}$	7.0	V
Voltage at any input	V_{IN}	$V_{SS} - 0.3$ to $V_{DD} + 0.3$	V
Operating temperature	T_A	-20 to +85	°C
Storage temperature	T_{STG}	-55 to +150	°C

DC ELECTRICAL CHARACTERISTICS:(Unless otherwise specified $V_{DD} = 3V$ to $5V$ and $T_A = -20^{\circ}C$ to $+85^{\circ}C$)

PARAMETER	SYMBOL	MIN	TYPE	MAX	UNITS	CONDITON
Supply Voltage	V_{DD}	3.0	-	5.5	V	-
Supply current	I_{DD}	-	30	45	μA	$V_{DD} = 3V$
	I_{DD}	-	110	150	μA	$V_{DD} = 5V$
MODE input:						
Logic 0	V_{ml}	-	-	0.6	V	-
Logic 1	V_{mh}	$V_{DD} - 0.6$	-	-	V	-
Logic float	V_{mf}	$(V_{DD}/2) - 0.5$	$V_{DD}/2$	$(V_{DD}/2) + 0.5$	V	-
Logic 0 input current	I_{ml}	-	3.0	5.0	μA	$V_{DD} = 3V$
	I_{ml}	-	12.0	16.0	μA	$V_{DD} = 5V$
Logic 1 input current	I_{mh}	-	-3.0	-5.0	μA	$V_{DD} = 3V$
	I_{mh}	-	-12.0	-16.0	μA	$V_{DD} = 5V$
A,B inputs:						
Logic 0	V_{ABI}	-	-	$0.3V_{DD}$	V	-
Logic 1	V_{ABh}	$0.7V_{DD}$	-	-	V	-
Input current	I_{ABik}	-	0	10	nA	-
RBIAS input:						
External resistor	R_B	5k	-	10M	ohm	-
All outputs:						
Sink current	I_{ol}	-1.2	-1.8	-	mA	$V_o = 0.5V, V_{DD} = 3V$
	I_{ol}	-2.5	-3.5	-	mA	$V_o = 0.5V, V_{DD} = 5V$
Source current	I_{oh}	1.2	1.8	-	mA	$V_o = 2.5V, V_{DD} = 3V$
	I_{oh}	2.5	3.5	-	mA	$V_o = 4.5V, V_{DD} = 5V$

TRANSIENT CHARACTERISTICS

(TA = -20°C to +85°C)

PARAMETER	SYMBOL	MIN	TYPE	MAX	UNITS	CONDITON
Output Clock Pulse Width	T_{OW}	190	-	-	ns	See Fig. 2
A,B inputs:						
Validation Delay	T_{VD}	-	25	50	ns	$V_{DD} = 5V$
	T_{VD}	-	50	100	ns	$V_{DD} = 3V$
Phase Delay	T_{PS}	$T_{VD} + T_{OW}$	-	Infinite	s	-
Pulse Width	T_{PW}	$2T_{PS}$	-	Infinite	s	-
Frequency	$f_{A,B}$	-	-	$1/(2T_{PW})$	Hz	-
Inupt to Output Delay	T_{DS}	-	200	270	ns	$V_{DD} = 3V$
	T_{DS}	-	110	150	ns	$V_{DD} = 5V$

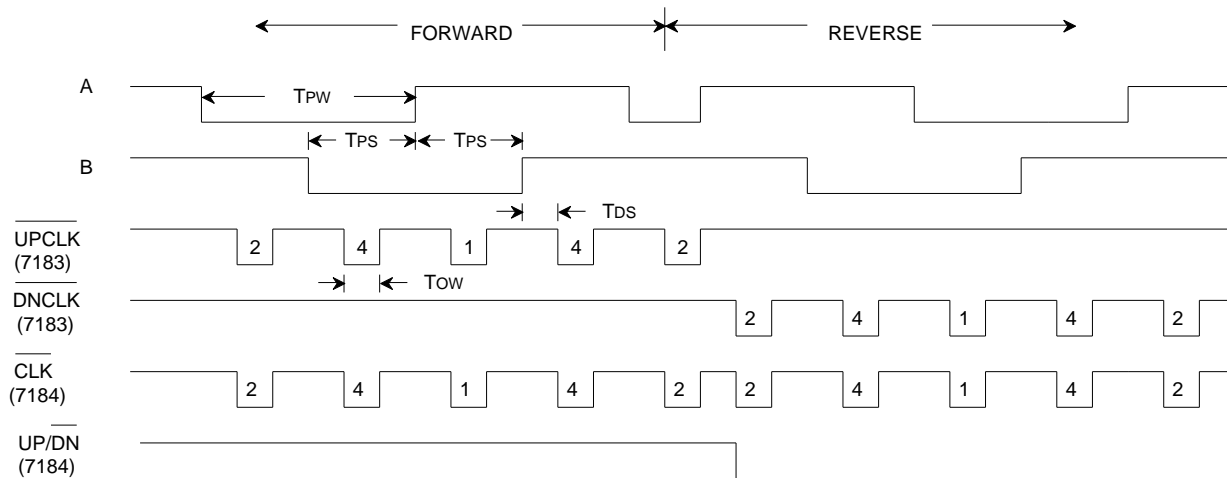

NOTE: Output clocks labelled 1, 2 and 4 have the following interpretations.
 1: Generated in x1, x2 and x4 modes
 2: Generated in x2 and x4 modes only
 4: Generated in x4 mode only

FIGURE 2. LS7183, LS7184 INPUT/OUTPUT TIMING

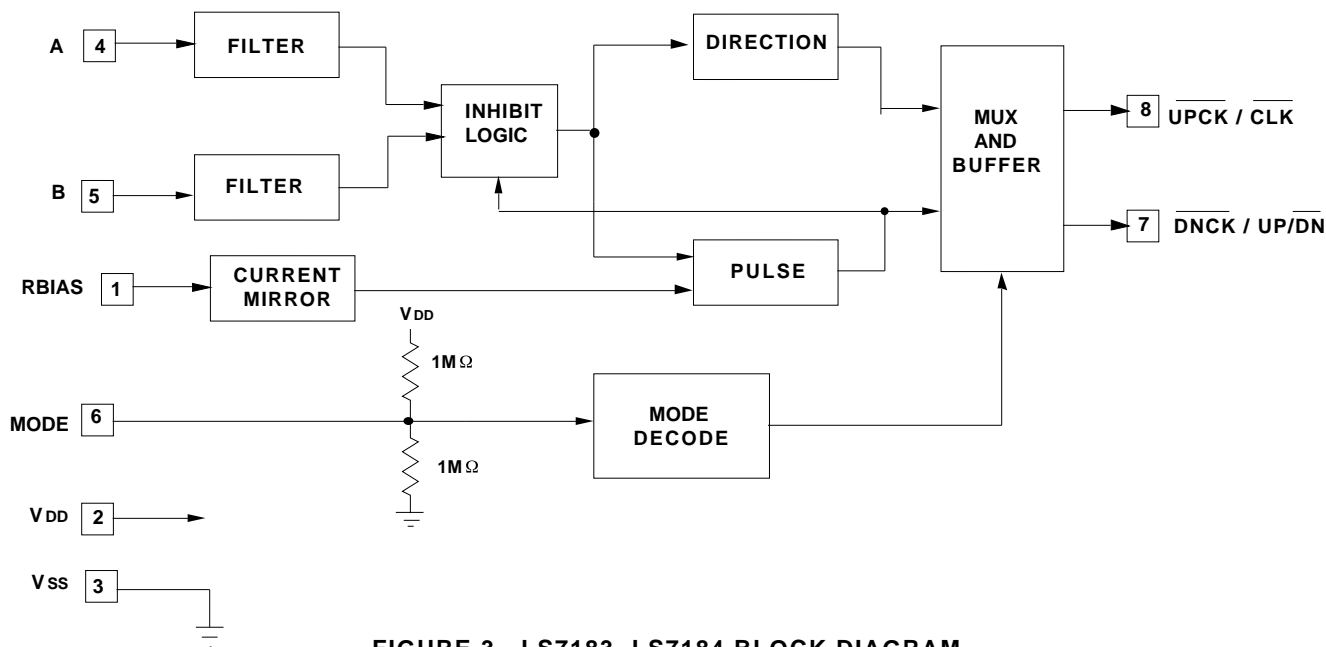

FIGURE 3. LS7183, LS7184 BLOCK DIAGRAM

The information included herein is believed to be accurate and reliable. However, LSI Computer Systems, Inc. assumes no responsibilities for inaccuracies, nor for any infringements of patent rights of others which may result from its use.

RBIAS vs Tow

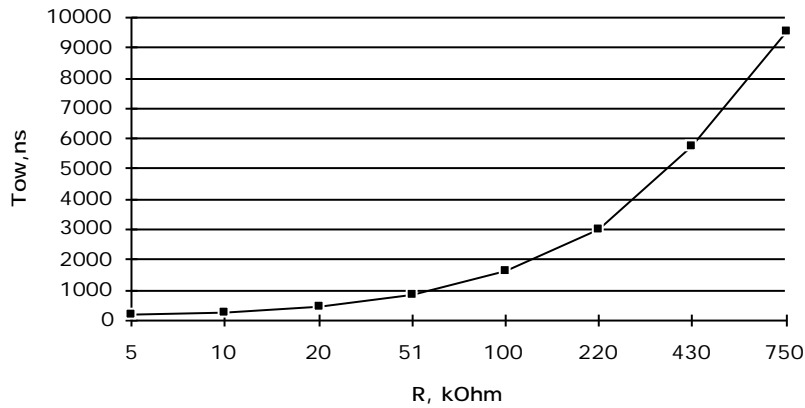

Figure 4. Bias resistance vs pulse width. R in kΩ.

RBIAS vs Tow

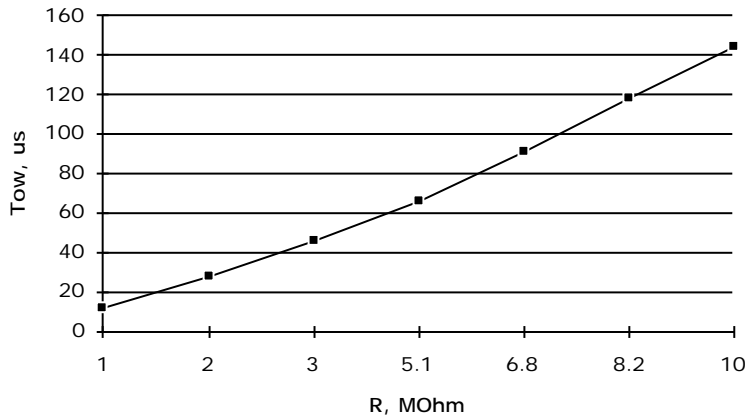

Figure 5. Bias resistance vs pulse width. R in kOhms.

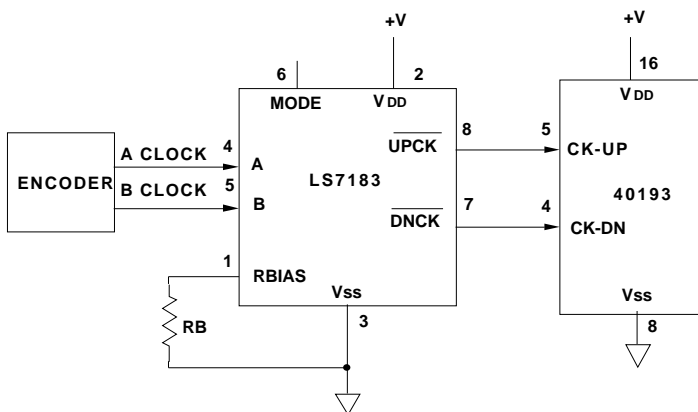

FIGURE 6A. TYPICAL APPLICATION FOR LS7183 IN x4 MODE

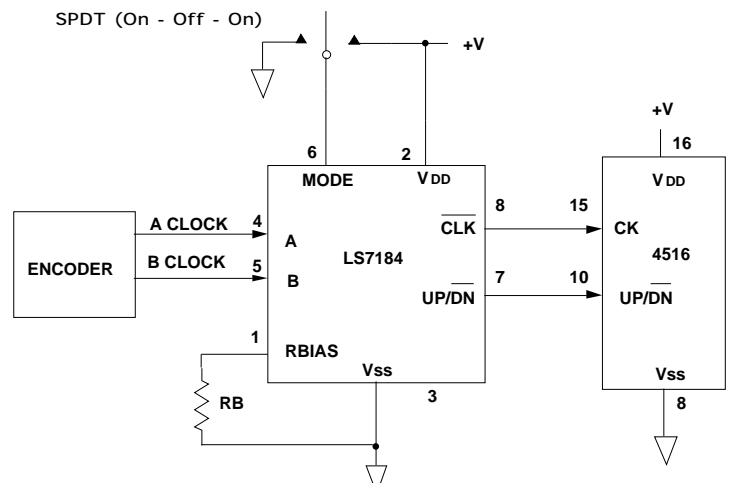

FIGURE 6B. TYPICAL APPLICATION FOR LS7184 WITH MODE SELECTION

Note: The CLK Output of LS7184 can be applied directly to the Clock Input of counters that advance on the positive edge of the Clock Input. If the Counter advances on the negative edge of the Clock Input, an inverter must be added between the CLK Output of LS7184 and the Clock Input of the Counter.