



Microstep stepping motor driver HP 5056

Soft- und Hardware Langenfeld, Stiftstr. 3, 86866 Mickhausen
Tel.: 082041281, Fax: 082041675
E-Mail: Langenfeld@pro-tos.de Homepage: <http://www.pro-tos.de>



Safety advice



The stepping motor output stage is a module without certain function but is assigned to be part of a system. During operation, the module can cause electromagnetic interferences. The assembly must comply strictly with the directions given in app. A and is to be carried out by special personnel. The occurring interference intensity depends on a number of factors, such as cable length, cable quality, current, motor rotation speed. Therefore - and in order to comply with EN 89/336(EMV law) - the system is to be inspected under normal operation conditions.

Before branching off connectors, make sure to

- disconnect power supply
- wait 10 seconds for discharge of the capacitor

Attention! With the motor disconnected the clamps are loaded with maximum voltage(depending on the power supply, up to 50 V).

Functions

- Microstep 15 step accuracy.
- Very quiet motor operation
- Very low heat development of motor and module
- Opto-coupled inputs
- Automatic lowering of current during stand-by(sleep)
- Excess voltage and short-circuit protection
- Current DIP-switch adjustable

Protection functions

- Excess voltage protection is activated when reaching 52 V and is indicated by red LED. With voltage falling beyond 20 V the function of the module is not guaranteed. P
- Protection against short-circuit between coil and GND. Once activated, the red LED is lighted.
- The protection mechanism avoids damage to the module.

Current adjustment by DIP-switch 1-3

Motor current (peak)	Motor current (RMS)	SW 1	SW 2	SW 3
1,4	1,0	OFF	OFF	OFF
2,1	1,5	ON	OFF	OFF
2,7	1,9	OFF	ON	OFF
3,2	2,3	ON	ON	OFF
3,8	2,7	OFF	OFF	ON
4,3	3,1	ON	OFF	ON
4,9	3,5	OFF	ON	ON
		ON	ON	ON

Select a setting that complies with the specifications of your stepping motor. In case a value is not available select the closest value from the table. Select the next lower value in favor of smooth operation and lower heat.

Automatic lowering of current

In order to reduce heat development of motor and module, the automatic current lowering function can be activated by SW 4 OFF. With the motor stopped the motor current is reduced to 50% 1 second after the last pulse. This reduction is automatically nullified before the following pulse.

Microstep Setting by DIP-switch 5 - 8

Micro step	Step / rev.with 1,8 deg. motors	SW 5	SW 6	SW 7	SW 8
2	400	OFF	ON	ON	ON
4	800	ON	OFF	ON	ON
8	1600	OFF	OFF	ON	ON
16	3200	ON	ON	OFF	ON
32	6400	OFF	ON	OFF	ON
64	12800	ON	OFF	OFF	ON
128	25600	OFF	OFF	OFF	ON
5	1000	ON	ON	ON	OFF
10	2000	OFF	ON	ON	OFF
20	4000	ON	OFF	ON	OFF
25	5000	OFF	OFF	ON	OFF
40	8000	ON	ON	OFF	OFF
50	10000	OFF	ON	OFF	OFF
100	20000	ON	OFF	OFF	OFF
125	25000	OFF	OFF	OFF	OFF

Output stage connectors, P1, P2

Signal input

Signal	Function
PUL + (+5V)	Step pulse. With the rising edge a step is actuated. The pulse width should be $>1,2\mu\text{S}$.
PUL - (PUL)	
DIR + (+5V)	Direction signal. High or Low level. Direction signal must be $2\mu\text{S}$ before step pulse.
DIR - (DIR)	
ENA + (+5V)	Enable Signal. This signal stops the current supply to the module. (f.ex. emergency exit). Normally set to high level, otherwise not connected.
ENA - (ENA)	

Motor voltage and motor connection

Pin Nr.	Signal	Function
1	GND	Motor voltage minus (ground)
2	+ V	Motors voltage + max 50V
3,4	Phase A	Motor coil phase A (A+ and A-)
5,6	Phase B	Motor coil phase B (B+ and B-)

Do never change the polarity of the motor voltage, this would damage the module!

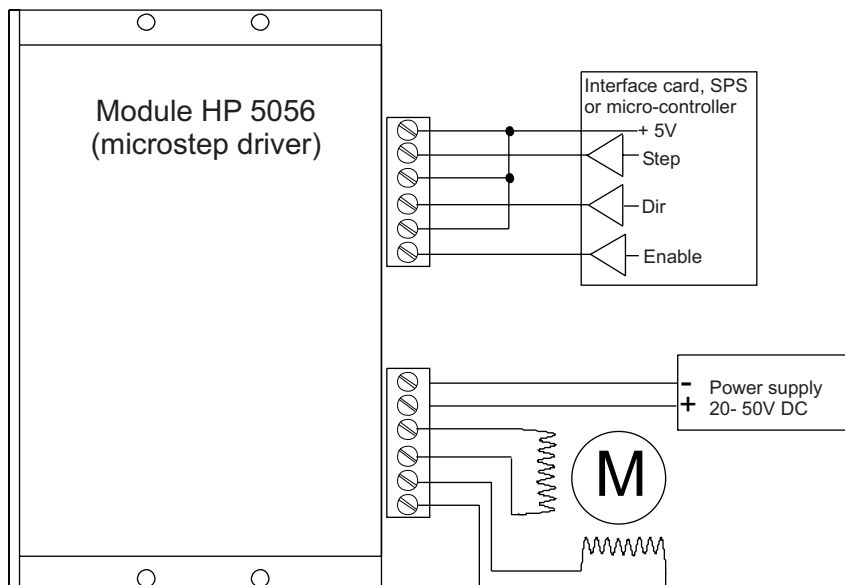

Appendix A

Elektromagnetic interference

During operation, module, motor and cable produce electromagnetic waves that interfere with other devices. In order to meet requirements of EN 89/339 it is necessary to follow the installation instructions(see also pic. 1):

- Module, power supply and all electronic parts needed for control are recommended to be combined in one shielded and earthed (metal-)casing.
- Earth cable must be short and low resistant.
- Outside the cover, the connecting cable for module and motor must be shielded. The shield is earthed inside the cover.
- A line filter must be switched between line cable and transformer. It should be positioned close to the cable cover entrance.

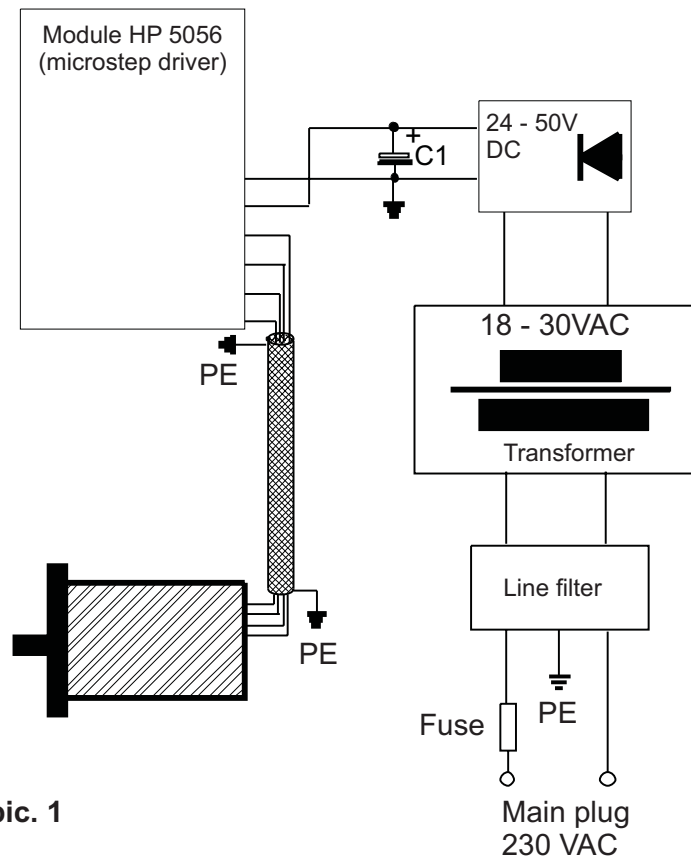

pic. 1