

TOSHIBA

Motor Drivers

Meet the new generation...

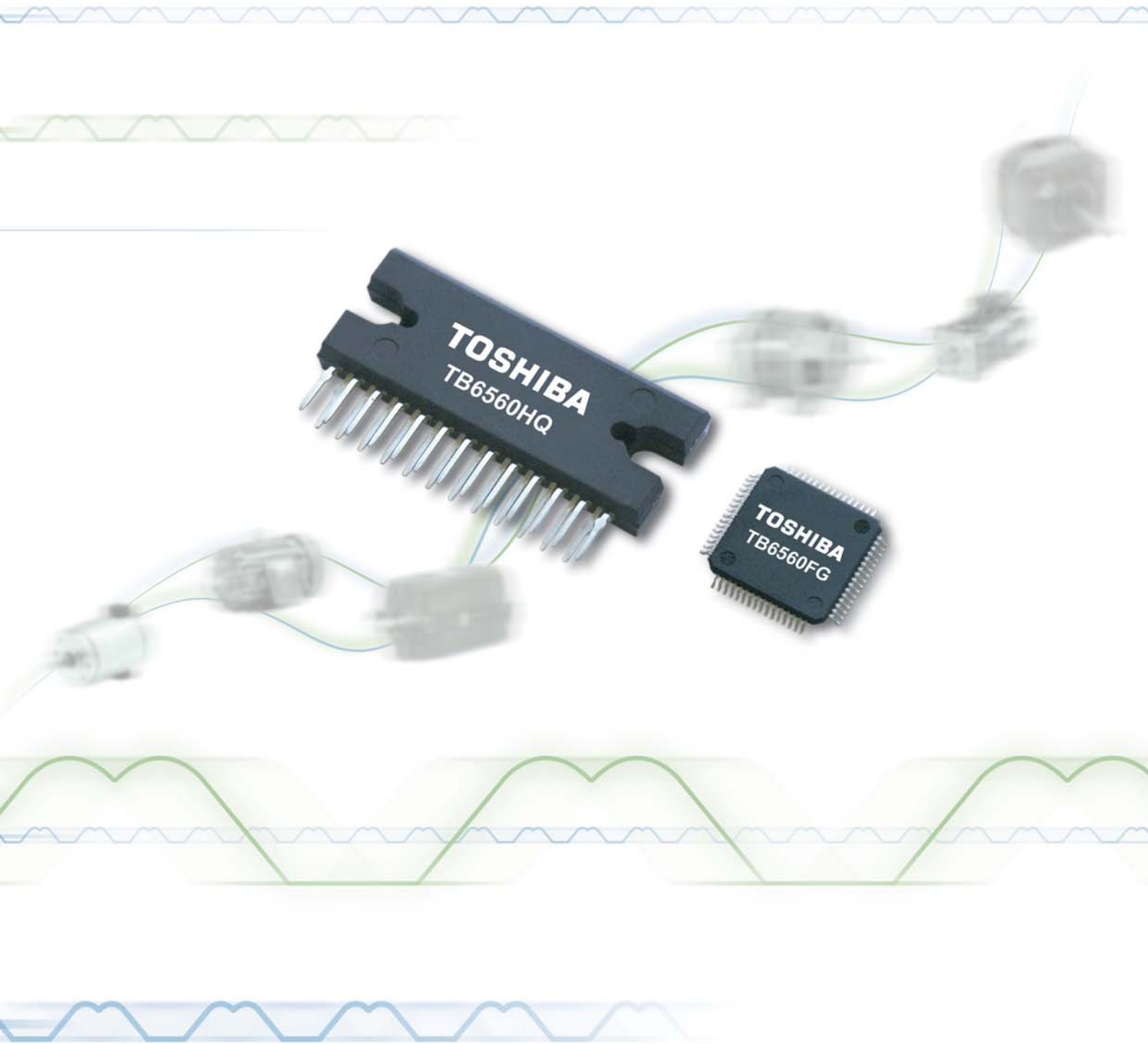

Meet the new generation...

Introduction

From office automation equipment to industrial pumps and fans, and from vending machines to home appliances, implementing efficient, reliable, accurate and cost-effective motion control systems has become an increasingly important aspect of modern application design. At the same time, the choice of motor technologies available to the designer has expanded to meet the increasingly sophisticated requirements of today's motion control applications.

To help engineers implement motion control systems that are optimised to the target application, Toshiba Electronics has developed a comprehensive range of motor drive and control ICs for brushed DC, brushless DC and stepper motor designs. By offering high levels of on-board functionality and performance in compact packaging, these ICs can help designers of motor-based applications to significantly reduce component count, PCB space and development time without compromising product performance.

Whether it's a single-bridge driver for a brushed motor design, a sensorless solution for a brushless DC motor, or a microstepping control system for a stepper motor, the information on this CD-ROM provides the information needed to identify and select the optimum Toshiba product to simplify and speed your application design.



BiCD the benefits

Toshiba's BiCD process (Integration of Bipolar transistors, CMOS FET and high-voltage and high-electric-current DMOS) allows for much larger power dissipation from ever smaller semiconductors. Devices that historically would need to be housed in leaded packages and heatsinked can now be replaced by surface mount devices. Obviously this is down to heat dissipation and the BiCD process is particularly effective at reducing the output saturation voltage resulting in much lower dissipated losses for any given current.

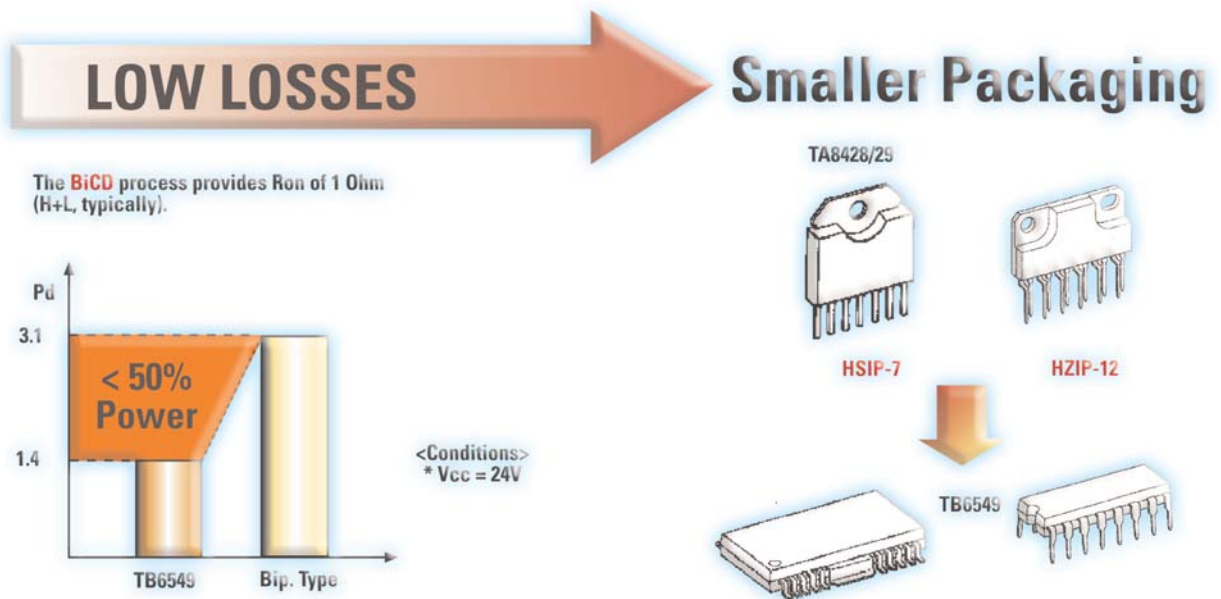

Meet the new generation...

Constant Current PWM

Given a constant PWM duty cycle, the current in the motor coils varies when the bridge voltage (the voltage applied to the supply terminal of the power H-bridge) changes. The bridge voltage is mainly influenced by battery voltage or on the type of load and in the presence of an AC rectifier it can show considerable 50/60Hz ripple. Levelling out these changes by a speed control loop e.g. through an external micro can prove difficult to implement as the speed control loop will typically operate on longer time constant. As such, it is generally recommended to use a voltage regulator to stabilise the bridge voltage with constant PWM or direct PWM systems.

A different approach is the constant current PWM topology realised increasingly in modern motor PWM controllers/drivers. The motor driver generates the PWM on chip and achieves the constant current by appropriate modulation of the PWM duty. In this case there is a feedback loop with a short time constant that is able to minimise the effects of power supply ripple and other voltage fluctuations. If required an external micro can additionally control speed by varying the target current at the motor driver input.

Using this topology the - expensive, high current - voltage regulator for the bridge voltage can be omitted altogether. This saves cost and - especially in the case of linear voltage regulators - improves overall system efficiency.





Brushed DC Motor Drivers

Offering mature and low cost motion control, brushed DC motors are a proven and reliable option for a wide variety of applications including toys, office automation products, industrial X-Y tables and medical equipment.

Toshiba's range of ICs for brushed DC motor motion control applications includes robust single and dual full-bridge drivers that combine high-precision speed and positioning control with protection and other integrated functionality. Low on-resistance (R_{DSon}) options deliver maximum efficiency and reduced heat dissipation in battery-powered designs, while PWM options support enhanced design flexibility.

DC brushed Drivers	Peak motor bridge voltage [V]	Ron Ω Typ. (H + L) [#]	Output peak current [A]	Nr. of brushed DC motors	PWM support	Input Interface	Package	Comment
TA8428FG/K	30	-	2,4 / 3	1	No	Logical 2 Bit	HSOP20/HZIP-7	Matured robust driver
TA8429HQ	30	-	4.5	1	No	Logical 2 Bit	HZIP12	Matured robust driver
TB62300FG	40	0.7	2.5	2	Yes	Serial	HSOP36	Mixed decay, several PWM modes, low count of external components
TB6549FG/PG/HQ	30	1	3,5 / 4,5	1	Yes	Logical 2 Bit	HSOP20/DIP16/HZIP25	3 package versions cover a wide power range
TB6552FG/FNG/FLG	15	1.5	1,5 / 1/1	2	Yes	Logical 2 Bit	HSOP16/SSOP16/QON24	Low R _{DSon} reduces dissipated heat and is particularly useful for battery powered applications
TB6555FLG	15	1.5	0.8	4	Yes	Logical 2 Bit	QUON36	Low R _{DSon} reduces dissipated heat and is particularly useful for battery powered applications
TB6558FLG	15	1.5	0.8	2	Yes	Logical 2 Bit	QUON24	Low R _{DSon} reduces dissipated heat and is particularly useful for battery powered applications
TB6559FG	50	1.5	2.5	1	Yes	Logical 3 Bit/Bridge	HSOP16	2 PWM driving schemes available, constant current on chip or direct PWM control from outside
TB6561FG/NG *)	40	1.5	1.5	2	Yes	Logical 2	SSOP30/NDIP24 Bit/Bridge	Low R _{DSon} reduces dissipated heat and is particularly useful for battery powered applications
TB6590FTG	6	2.5	0.5	2	Yes	Logical 2 Bit	VQON16	Small package (3x3mm)
TB6592FLG	6	1.5	0.8	2	Yes	Logical 2 Bit	QUON24	Low R _{DSon} reduces dissipated heat and is particularly useful for battery powered applications
TB6593FNG	6	0.35	3.2	1	Yes	Logical 2 Bit	SSOP20	Lowest Ron with small package, ideal for low voltage battery powered equipment
TB6594FLG	6	1.5	0.8	2	Yes	Logical 2 Bit	QUON26	2 H-bridges 5V, DC DC converter
TB6595FLG	6	1.5	0.8	4	Yes	Logical 2 Bit	QUON24	Low R _{DSon} reduces dissipated heat and is particularly useful for battery powered applications
TB6612FNG	15	0.5	3.2	2	Yes	Logical 2 Bit	SSOP24	Low R _{DSon} reduces dissipated heat and is particularly useful for battery powered applications

*) SOP version under development

Combined resistance of upper and lower parts of the bridge

Meet the new generation...

Brushed DC Motor Drivers - Block Diagrams

TB6592 - low $R_{ds(on)}$ 3A H-bridge driver for DC motors

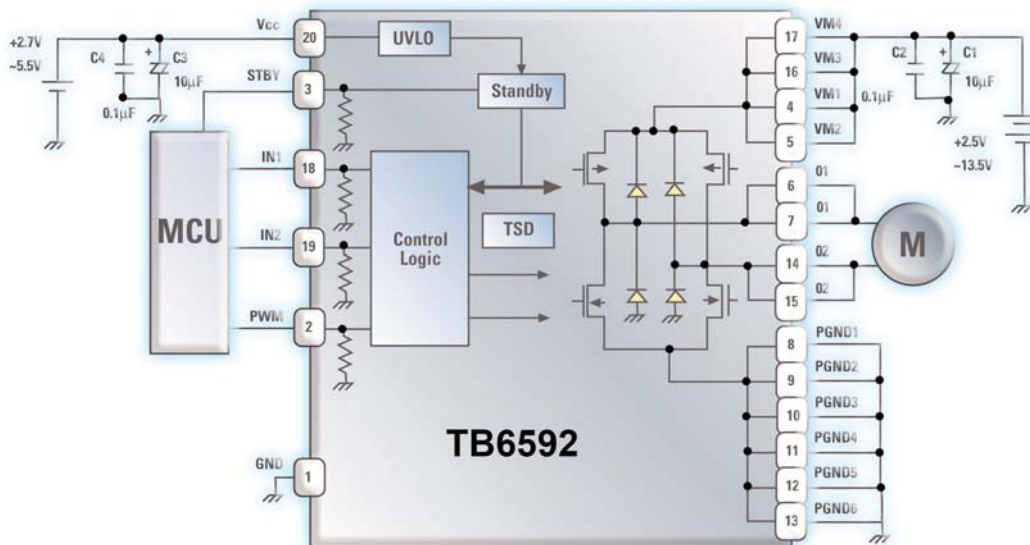

TB6561 - dual 1.5A H-bridge driver for DC motors

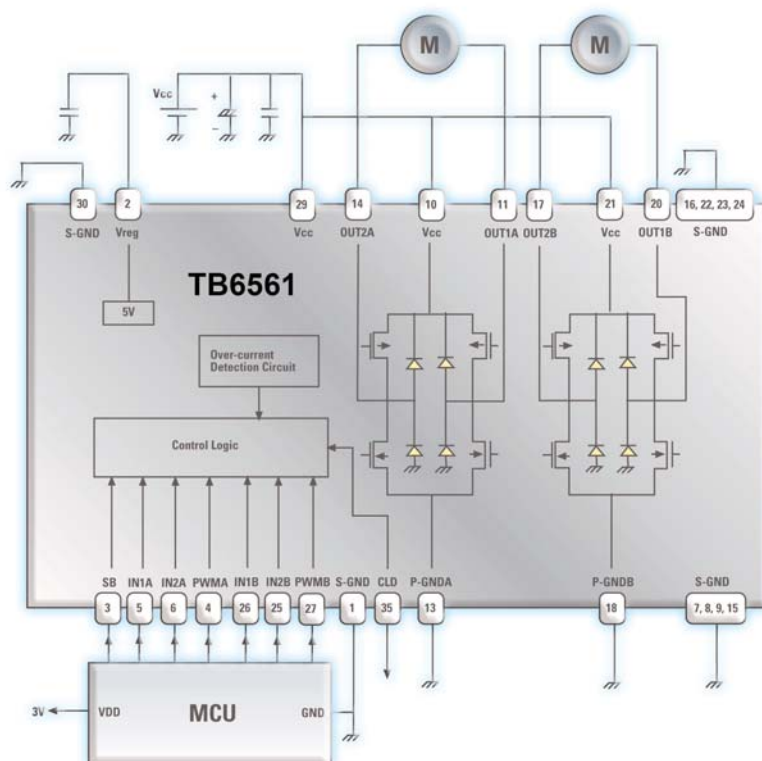

Brushed DC Motor Drivers - Block Diagrams

TB6559 - 2.5A H-bridge driver with two PWM schemes selectable

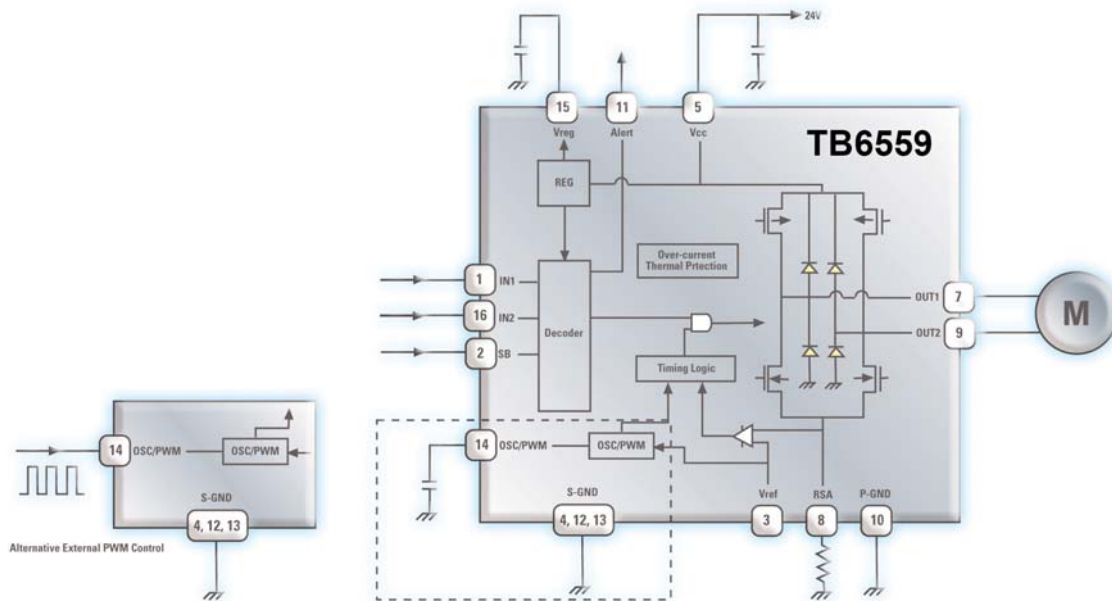

TB6549 - 3.5/4.5A H-bridge driver, 3 package choices

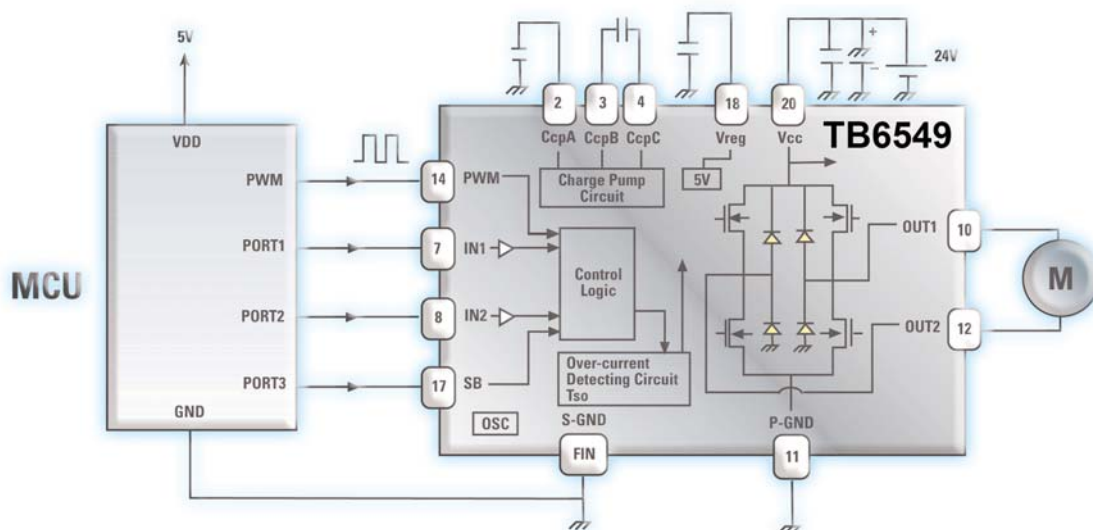

Meet the new generation...

Brushed DC Motor Drivers - Block Diagrams

TB62300 - 2.5A H-bridge driver with serial input

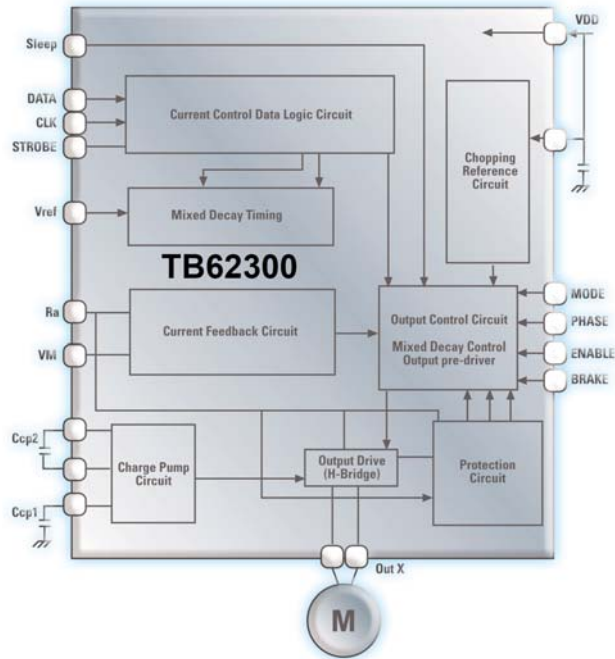

TB62300 - Typical application circuit

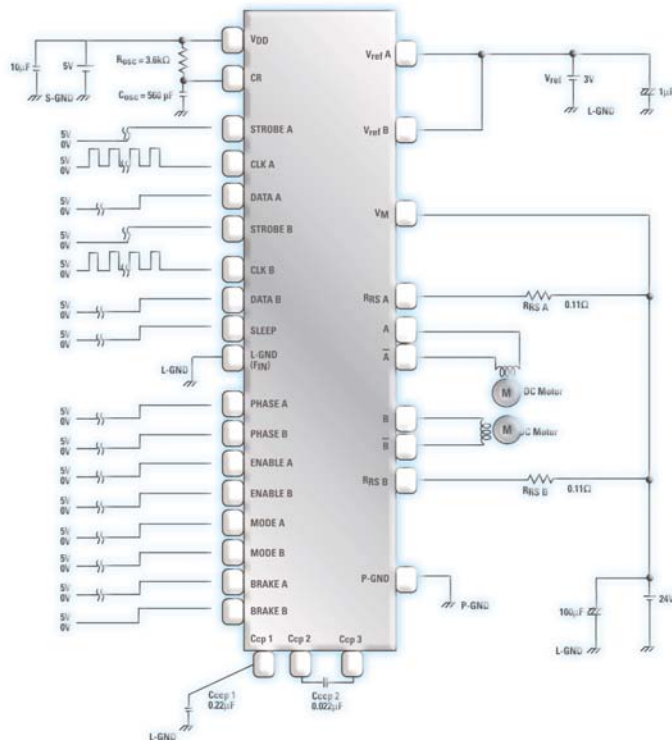

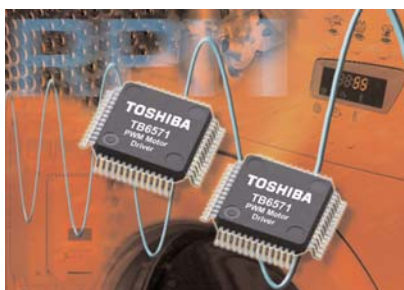

BLDC Controllers and Drivers

Demand for brushless DC (BLDC) motors is growing, fuelled by a combination of their inherent reliability and dynamic response, commercial, environmental and legislative pressure for improved efficiencies, and ongoing decreases in the cost of BLDC technology.

Featuring on-chip PWM support for optimum efficiency and sine wave options to minimise acoustic and electrical noise, Toshiba's comprehensive range of IC drivers and controllers for BLDC motors provides for sensor-based and sensorless control and offers peak output currents from 2mA to 2.5A. For ultimate integration levels, Toshiba's TB6581 inverter/driver can provide a complete 230VAC/1A sinewave BLDC driver in a single package.

BLDC Controller/Driver	Peak motor bridge voltage [V]	Ron Ω Typ. (H + L) [#]	Output peak current [mA]	Nr. of BLDC motors	PWM support	BLDC System	Package	Comment
TB6537FG/PG	5.5	-	20	1	Yes	Sensorless	SSOP24/DIP18	Sensorless controller/predriver with direct PWM type input control
TB6539FG/NG	18	-	20	1	Yes	3 Hall IC/ Sinewave	SSOP30/NDIP24	Same function as TB6551 but higher Output Voltage and current, DIL package
TB6551FG	12	-	2	1	Yes	3 Hall IC/ Sinewave	SSOP24	Shrink version of TB6539, low cost
TB6556FG	12	-	2	1	Yes	3 Hall IC/ Sinewave	SSOP24	Function like TB6551 plus auto lead angle function
TB6571FG	30	-	20	1	Yes	3 Hall sensors/ Sinewave	QFP52	Same function as TB6556 plus gate driver and alternative PCB pattern coil based speed signal generator, speed control loop included
TB6575FNG	5.5	-	20	1	Yes	Sensorless	SSOP24	Sensorless controller/predriver with on chip PWM generation
TB6581HG	500	2.8	1000	1	Yes	3 Hall IC/ Sinewave	HZIP25	TB6551 and 1A/500V single chip inverter in one package, complete 230Vac/1A sinewave BLDC driver in 1 package
TB6588FG *)	42	0.5	2500	1	Yes	Sensorless	HSOP36	Function of TB6575 but combined with complete driver, monolithic

*) Under development; published data in the table could be revised for the final product

Combined resistance of upper and lower parts of the bridge

Meet the new generation...

BLDC Controllers and Drivers - Block Diagrams

TB6571 - hall sensor based sine wave BLDC controller predriver

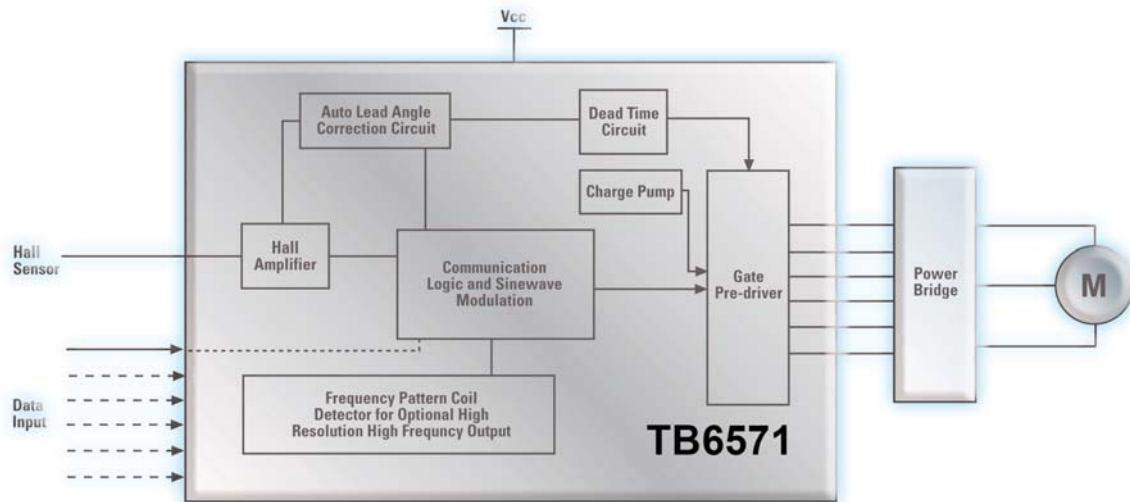

TB6581 - complete 3 phase BLDC 500V/1A sine wave system in a package

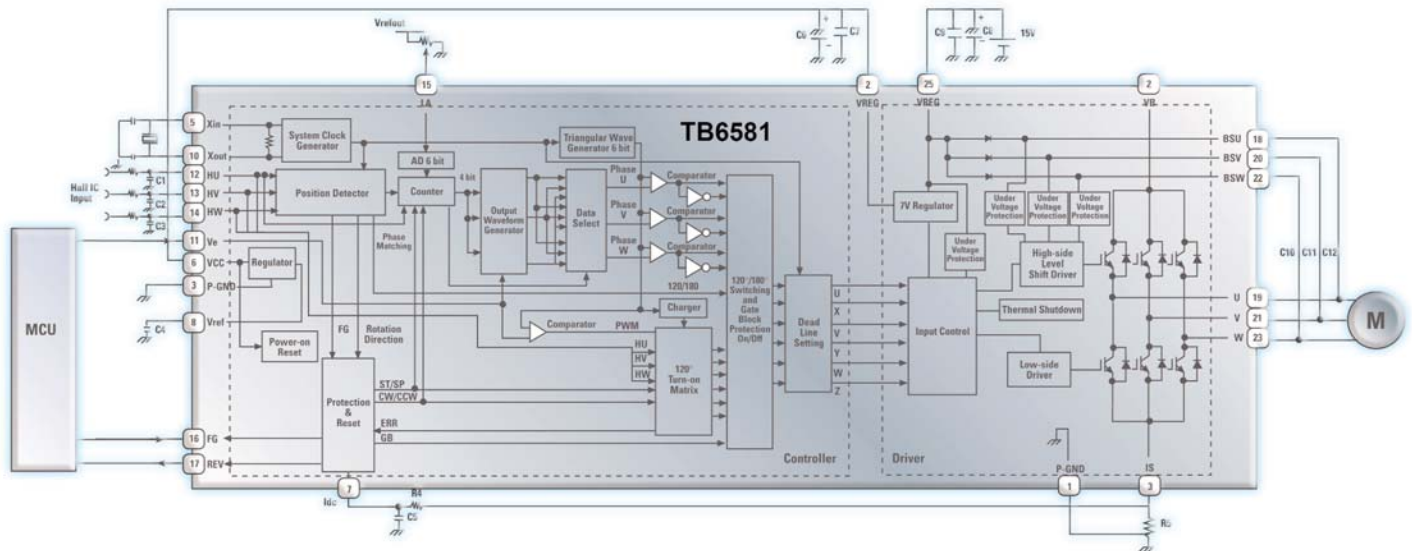

BLDC Controllers and Drivers - Block Diagrams

TB6539 - 3 phase BLDC sine wave controller with 20MHz gate predriver

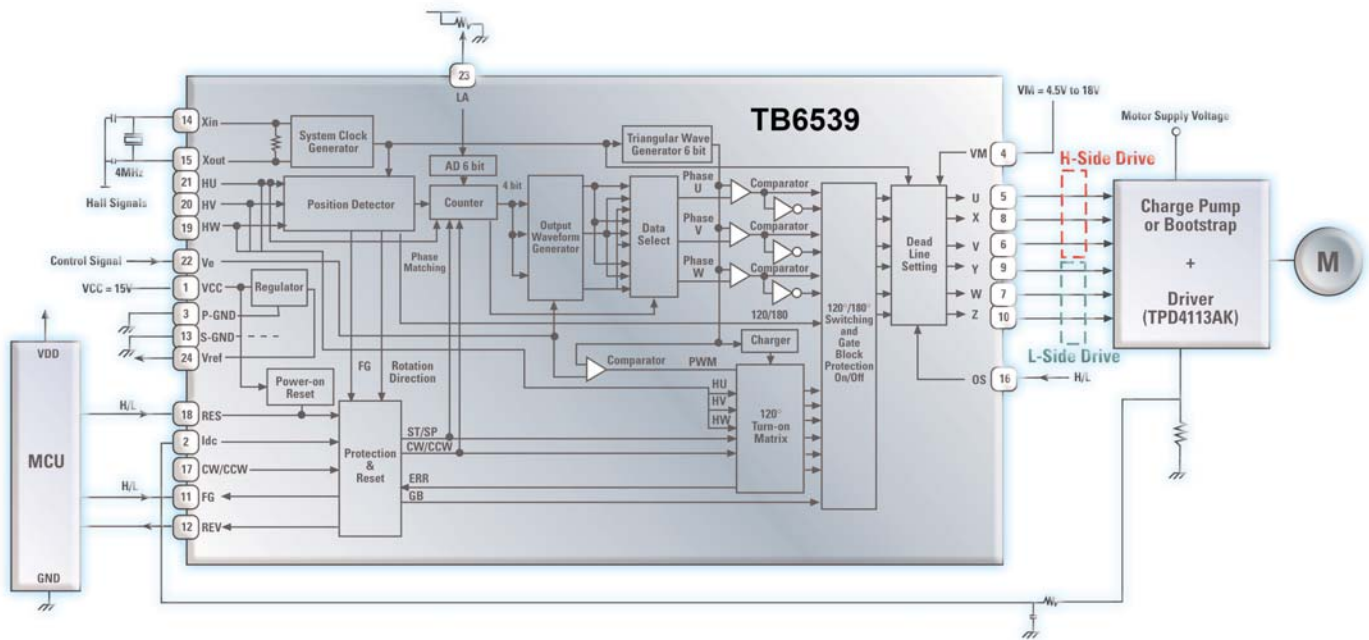

TB6575 - 3 phase BLDC sensorless controller with PWM generation on chip

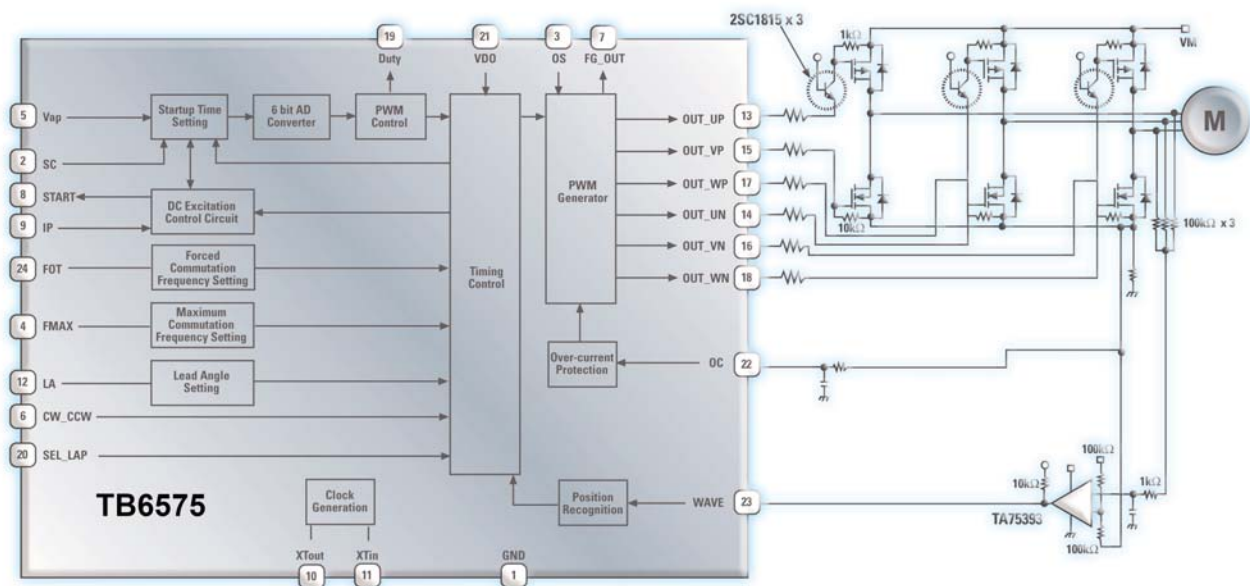

Meet the new generation...

Stepper Drivers

Stepper motors have become the motor of choice in a variety of open loop applications where accuracy, repeatability and maintenance-free operation rather than high speed and acceleration are key.

Toshiba's stepper motor ICs combine drive capability with functions that allow control overhead to be offloaded from the host microcontroller. The devices feature internal PWM current control and offer drive modes for 1/2, 1/8 and 1/16 step operation. Parts with selectable mixed decay modes allow designers to minimise both audible noise and vibration by minimising PWM ripple on the microstepping output.



Stepper Drivers	Peak motor bridge voltage [V]	Ron Ω Typ. (H + L)*	Output peak current [A]	Nr. of stepper motors	PWM support	Input Interface	Package	Comment
TA84002FG	35	-	1	1	Yes	Phase	HSOP20	Multichip 4 PMOS FETs and 1 controller chip, Phase input (2Bit per phase)
TA8435HQ	50	-	2.5	1	Yes	Clock-In	HZIP25	1/8 step, lead free finish (some lead used inside)
TB62206FG	40	1.1	1.8	1	Yes	Phase	HSOP20	1/2 step, mixed decay, separate Vref for each phase
TB62201AFG	40	1.1	1	2	Yes	Serial	HSOP36	1/16 step, mixed decay
TB62202AFG	40	2.5	1.5	2	Yes	Serial	HSOP36	1/16 step, mixed decay
TB62207BFG	37	1.4	"2,5/1,3"	2	Yes	Serial	HSOP36	1/16 step, mixed decay
TB62209FG	40	1.1	1.8	1	Yes	Clock-In	HSOP36	1/16 step, mixed decay
TB62227AFG *)	40	1.4	2.5	2	Yes	Serial	THQFP64	1/16 step, mixed decay
TB6560HQ/FG	40	0.6	3.5	1	Yes	Clock-In	HZIP25/THQFP64	1/8 step, mixed decay
TB6562ANG/AFG	40	1.5	1.5	1	Yes	Phase	NDIP24/SSOP30	Separate Vref for each phase
TB6598FNG	15	1.5	0.8	1	Yes	Logical	SSOP16	1-2phase, constant current PWM
TB6608FNG	13	1.5	0.8	1	Yes	Clock-In	SSOP20	μ -stepping, 2W1-2phase and more driving schemes, mixed decay, constant current chopping

*) successor under development

Combined resistance of upper and lower parts of the bridge

The advantages of Micro Stepping

Micro stepping has three benefits.

1. It allows a stepping motor to stop and hold its position between the full or half-step positions.
2. It largely eliminates the noise at intermediate speeds and also the jerky character of low speed operation.
3. Reduction of resonance problems.



Stepper Drivers - Block Diagrams

TB6562 - 1.5A stepper driver with external V_{ref} input for optional external control

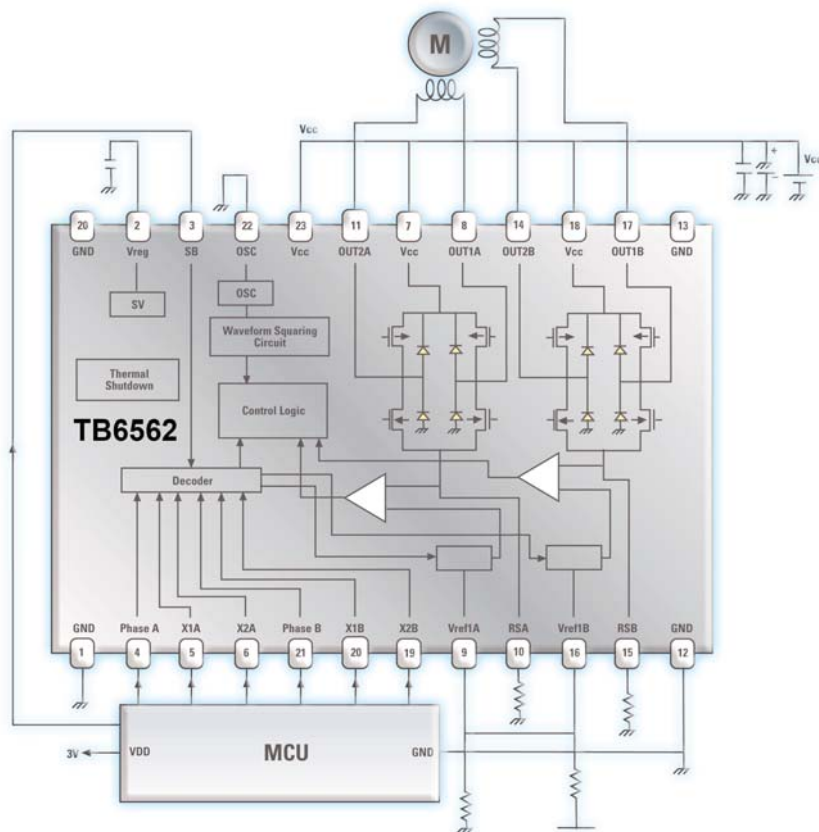

TB6598 - 0.8A stepper driver with constant PWM drive and operation from battery voltages

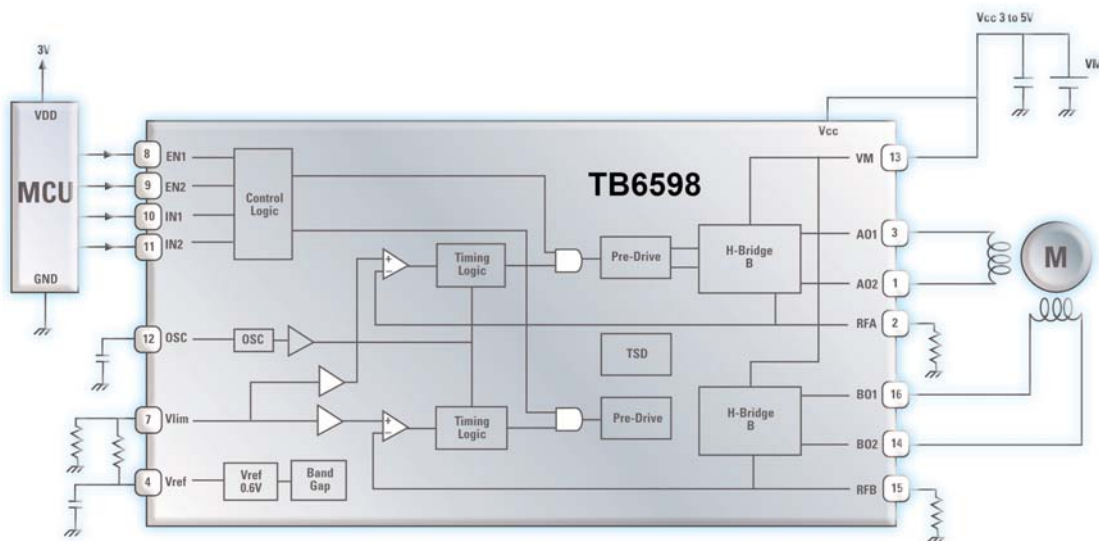

Meet the new generation...

Stepper Drivers - Block Diagrams

TB6560 - 3.5A/0.6Ω stepper driver with micro step generation on chip

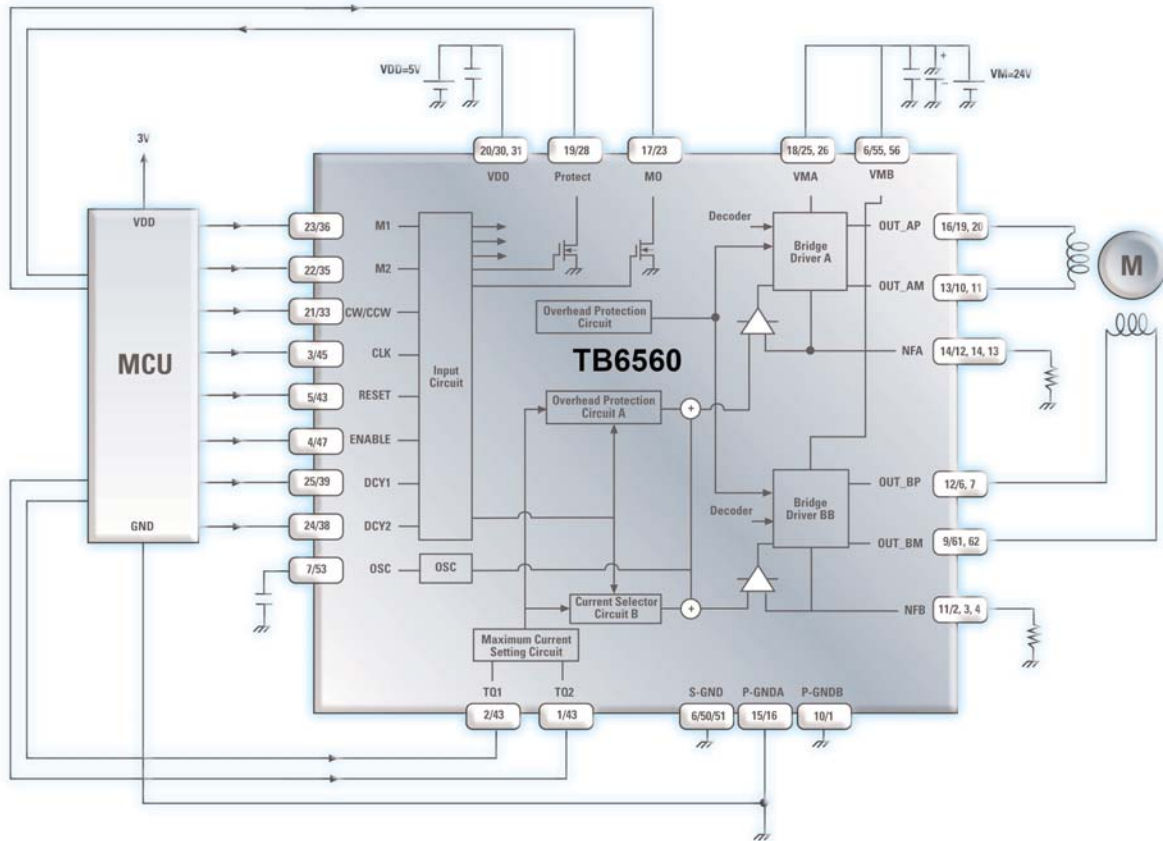

Typical block diagrams/application circuits

TB62209/1 - 1 Ω , 1A microstepper driver - System diagram for fully featured control

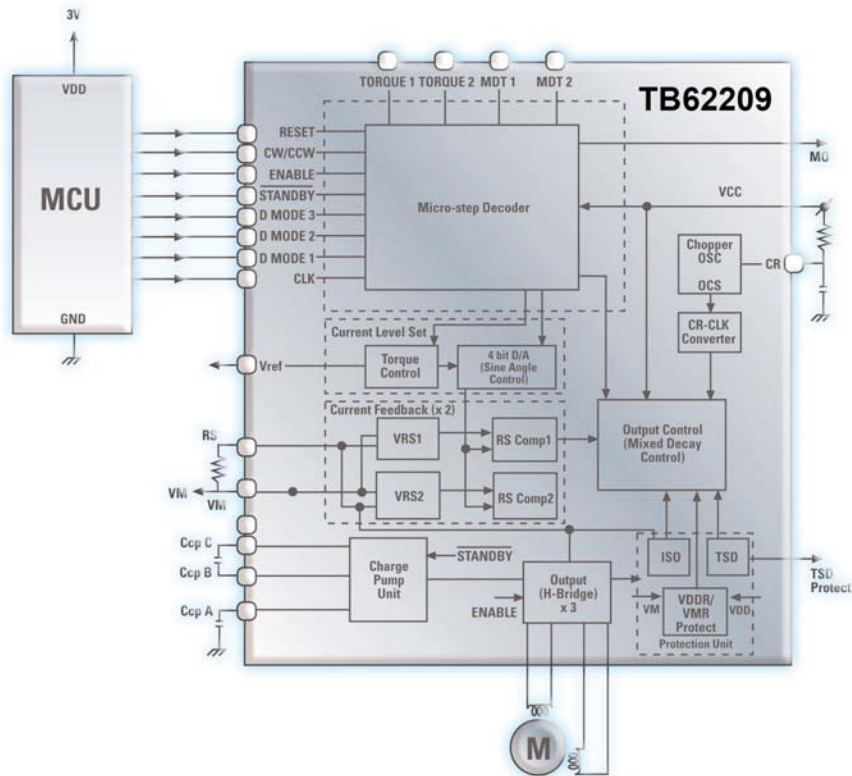

TB62209/2 - 1 Ω , 1A microstepper driver - Example of alternative system configuration with locally hard wired features and simple remote control via clock

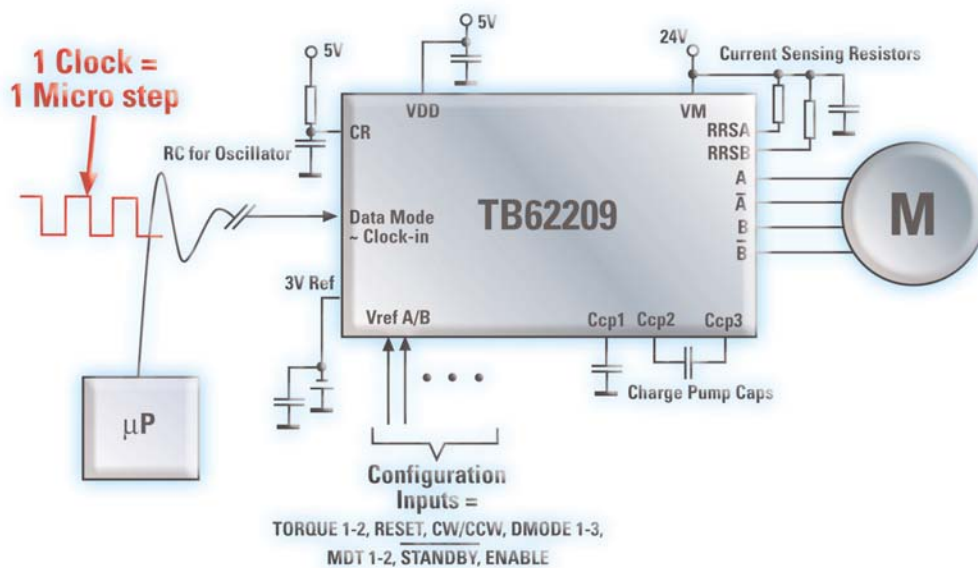

Toshiba Offices in Europe

GERMANY DÜSSELDORF

Hansaallee 181
40549 Düsseldorf
Germany
Tel.: +49-211-5296-0
Fax: +49-211-5296-400

MUNICH

Hofmannstr. 52
81379 München
Germany
Tel: +49-89-7485950
Fax: +49-89-74859542

FRANCE

Les Jardins du Golf
6 rue de Rome
93561 Rosny-sous-Bois
Cedex
France
email: contacttef@toshiba-components.com

ITALY

Centro Direzionale Colleoni
Palazzo Perseo 3
20041 Agrate Brianza MI
Italy
Tel: +39-039-68701
Fax: +39-039-6870205

SPAIN

Parque Empresarial, San Fernando
Edificio Europa, 1a Planta
E-28830, Madrid
Spain
Tel: +34-916-606792
Fax: +34-916-606799

SCANDINAVIA

Gustavslundsv. 18, 5th Floor
S-16715 Bromma
Sweden
Tel: +46-8-704-0900
Fax: +46-8-80-8459

UK

Riverside Way, Camberley
Surrey GU15 3YA
United Kingdom
Tel: +44-1276-694600
Fax: +44-1276-69-4800

<http://www.toshiba-components.com>

TOSHIBA is continually working to improve the quality and reliability of its products. Nevertheless, semiconductor devices in general can malfunction or fail due to their inherent electrical sensitivity and vulnerability to physical stress. It is the responsibility of the buyer, when utilizing TOSHIBA products, to comply with the standards of safety in making a safe design for the entire system, and to avoid situations in which a malfunction or failure of such TOSHIBA products could cause loss of human life, bodily injury or damage to property. In developing your designs, please ensure that TOSHIBA products are used within specified operating ranges as set forth in the most recent TOSHIBA products specifications. Also, please keep in mind the precautions and conditions set forth in the "Handling Guide for Semiconductor Devices," or "TOSHIBA Semiconductor Reliability Handbook" etc..

The Toshiba products listed on this document are intended for usage in general electronics applications (computer, personal equipment, office equipment, measuring equipment, industrial robotics, domestic

appliances, etc.). These Toshiba products are neither intended nor warranted for usage in equipment that requires extraordinarily high quality and/or reliability or a malfunction or failure of which may cause loss of human life or bodily injury ("Unintended Usage"). Unintended Usage include atomic energy control instruments, airplane or spaceship instruments, transportation instruments, traffic signal instruments, combustion control instruments, medical instruments, all types of safety devices, etc.. Unintended Usage of Toshiba products listed in this document shall be made at the customer's own risk.

The products described in this document may include products subject to the foreign exchange and foreign trade laws.

The information contained in this document is presented only as a guide for the applications of our products. No responsibility is assumed by TOSHIBA for any infringements of patents or other rights of the third parties which may result from its use. No license is granted by implication or otherwise under any patent or patent rights of TOSHIBA or others.