

POWERMAX II®

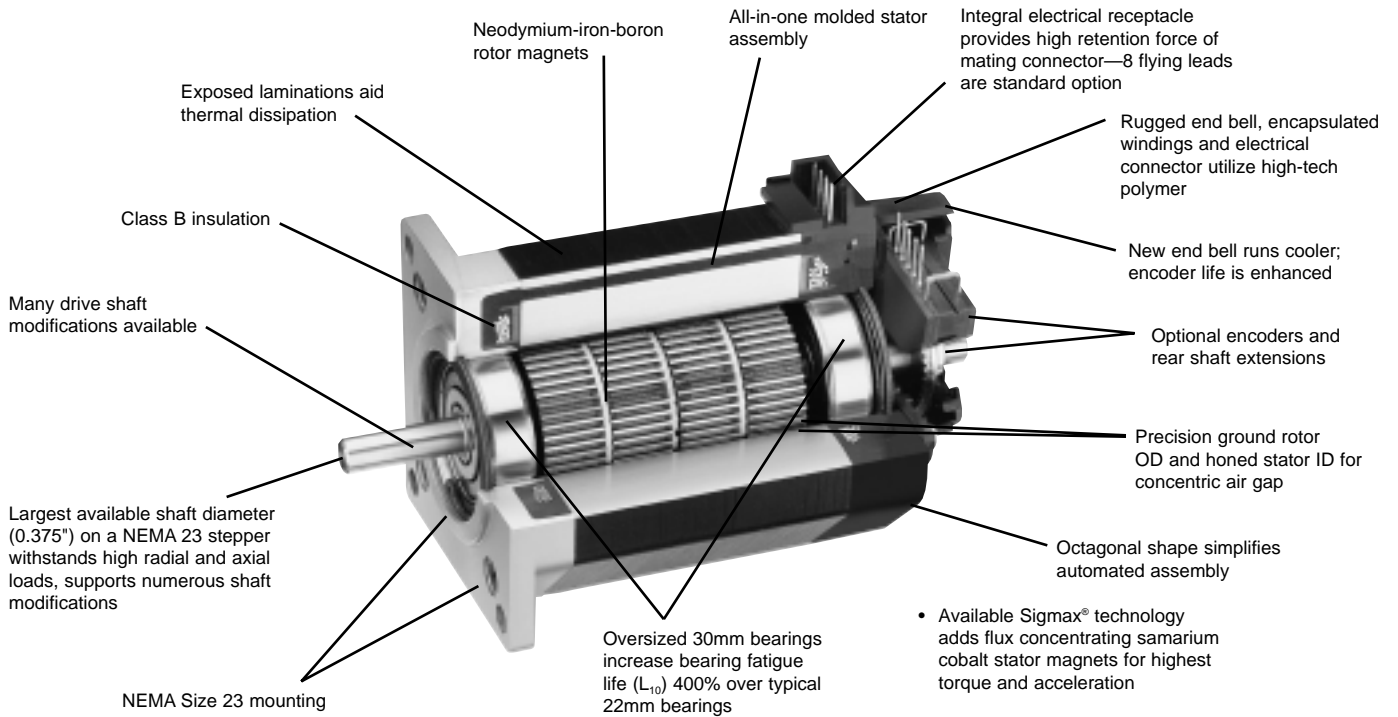

MODEL NUMBER CODE POWERMAX II® motors

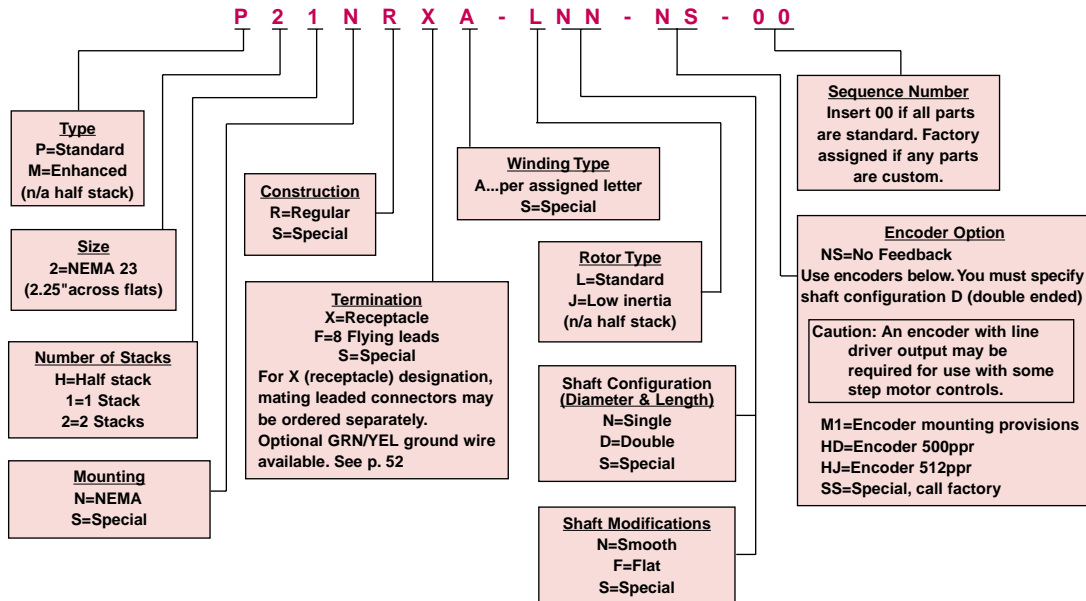

The example model number above indicates a standard NEMA 23 frame motor with a one stack rotor. This motor is equipped with a standard NEMA mount, regular construction, receptacle and an A winding. It also has a standard rotor, a smooth single-ended shaft and no encoder or encoder mounting provisions.

HOW TO ORDER

Review the Motor Model Number Code to assure that all options are designated. Dimensions, connections and phasing diagrams start on page 49. Encoder mounting options are on page 53.

POWERMAX II®



POWERMAX II® sets the world performance standard for NEMA 23 step motors. At up to 253 oz-in. holding torque, you won't find a more powerful two inch stepper.

With POWERMAX II you also gain the cost advantages of design for manufacturability (DFM) and North America's most advanced step motor manufacturing line.

That makes POWERMAX II economical without sacrificing features - such as long life bearings, high temperature insulation and quality magnet materials.

Plus DFM means we can build POWERMAX II to your specifications, in the volumes you need, according to your JIT or other delivery schedule.

Standard

Standard POWERMAX II motors come in half, single and two stacks that provide holding torques from 42 to 253 oz-in.

Custom

POWERMAX II proves that an economical step motor doesn't have to limit your options. It's just the opposite, thanks to flexible manufacturing.

Whether you require a simple drive shaft flat or an integral lead screw, POWERMAX II motors are made to order.

FEATURES

Two Year Warranty

New Polymer Encapsulated Stator

New Polymer End Bell with Threaded Inserts

Largest Available Shaft Diameter on a NEMA 23 Stepper

Oversized 30mm Bearings

Sigma[®] Technology

Optional Low Inertia Rotor

Optional Solid Rotor

Precision Ground Rotor OD and Honed Stator ID for Concentric Air Gap in an Economical Motor Design

Exposed Laminations Aids Thermal Dissipation

High Performance Gearheads



BENEFITS

High quality, dependable operation

Exceptional thermal dissipation

End bell runs cooler, provides greater flexibility in mounting encoder and brake options

Withstands high radial and axial loads. Supports numerous shaft modifications.

Increases bearing fatigue life (L_{10}), extends motor life, reduces downtime

Increases available torque

Produces the highest acceleration rate possible

High low speed torque, fast settling, superior stiffness and damping

High quality performance in an economical motor design.

Improved heat dissipation extends motor life, reduces downtime.

Increases torque range in a reliable, complete package

POWERMAX II® MOTOR TECHNOLOGY

Pacific Scientific developed POWERMAX II® to be the best cost/performance value available in hybrid step motors.

That's why you'll find so many standard POWERMAX II models in the universal NEMA 23 frame size. With POWERMAX II, you can tailor motor torque, acceleration and inertia to every axis of your design. And you can do this economically too, using a single mounting configuration and the driver of your choice.

Does your application require that extra measure of performance? Then consider the POWERMAX II M Series, featuring the patented Sigmax® technology.*

Samarium cobalt magnets in M Series motors concentrate magnetic flux at desired points between the rotor and stator. Sigmax technology optimizes flux paths to increase torque production and current utilization over conventional hybrid designs.

P SERIES STANDARD HYBRID

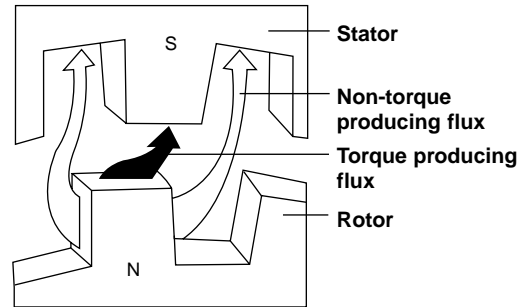

Typical paths of flux transfer in an energized conventional hybrid step motor. Some flux leakage occurs in normal operation.

M SERIES ENHANCED HYBRID SIGMAX® TECHNOLOGY

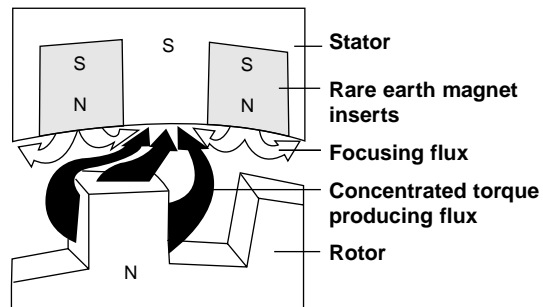

Patented Sigmax® technology* redirects magnetic flux to inhibit leakage and optimize torque production.

* Sigmax® technology is covered by U.S. patents 4,712,028, 4,713,470, 4,763,034 and 4,827,164.

TECHNICAL OVERVIEW

Types

POWERMAX II M Series	Hybrid step motors with rare earth magnets in the stator teeth
POWERMAX II P Series	Hybrid step motors

Rotor construction

POWERMAX II M and P Series; with "L" rotor designates	Laminated (high speed efficiency)
POWERMAX II M and P Series; with "J" rotor designates	Low mass/low inertia (fast start/stop, high acceleration)

Windings

A, B, C, D, E, F, G	Standard winding to match any application
---------------------	---

Phases

	2
--	---

Full steps per revolution

	200
--	-----

Full step angle

	1.8°
--	------

Angular accuracy

POWERMAX II M and M "J"	±1.5% of one step, no load, non-cumulative
POWERMAX II P and P "J"	±3% of one step, no load, non-cumulative

Operating temperature

	-20 to 40°C
--	-------------

Insulation

	NEMA Class B, 130°C
--	---------------------

Insulation resistance

	100 Megohms @500V dc and 25°C
--	-------------------------------

Shaft load ratings

Max. radial load (at center of std. shaft extension)	20 lb.
Max. axial load (on front shaft extension toward motor)	13 lb.

Bearing life

Since large bearings (30 mm) are used, life is typically about 4 times that of 22 mm or smaller bearings used on other NEMA Size 23 motors. POWERMAX II bearing fatigue life (L₁₀) exceeds 10,000 hours at any rotational speed up to 10,000 full steps/second if operated within the max. radial and axial loads specified above.

Encoder options

See page 53.

POWERMAX II® HYBRIDS

NEMA 23 FRAME (2.3")—Ratings and Characteristics

Review the Model Number Code on page 39 to assure that all options are designated. Dimensions, connections and phasing diagrams are on page 49. In addition to those below, motors with characteristics for specific performance requirements are offered. Contact factory for more details.

Motor Model Number	Connection [△]			Holding Torque [△]	Rated Current/Phase [△]	Phase Resistance (ohms) [△]	Phase Inductance [△]	Detent Torque [△]	Thermal Resistance [△]	Rotor Inertia [△]	Weight
	Parallel	Series	Unipolar	(2 phases on) oz-in (Nm) ±10%	(amps DC)	±10%	(mH) Typical	oz-in (Nm)	(°C/watt)	oz-in-S ² (kgm ² x 10 ⁻³)	lbs (kg)
Torque range: 42-61 oz-in. .29-.43 Nm											
P2HNXXH-LXX-XX-00	•			59 (0.42)	5.2	0.22	0.5				
P2HNXXH-LXX-XX-00		•		59 (0.42)	2.6	0.90	1.9				
P2HNXXH-LXX-XX-00			•	42 (0.29)	3.68	0.44	0.5				
STANDARD P2H Series 1/2 rotor stack											
P2HNXXB-LXX-XX-00	•			59 (0.42)	2.6	0.76	1.9				
P2HNXXB-LXX-XX-00		•		59 (0.42)	1.3	3.04	7.6				
P2HNXXB-LXX-XX-00			•	42 (0.29)	1.84	1.52	1.9	2.5 (0.018)	6.6	0.0010 (0.007)	1.0 (0.45)
P2HNXXC-LXX-XX-00	•			61 (0.43)	2.5	0.84	2.3				
P2HNXXC-LXX-XX-00		•		61 (0.43)	1.25	3.36	9.2				
P2HNXXC-LXX-XX-00			•	43 (0.30)	1.77	1.68	2.3				
P2HNXXF-LXX-XX-00	•			60 (0.42)	1.61	1.92	5.1				
P2HNXXF-LXX-XX-00		•		60 (0.42)	0.80	7.68	20.4				
P2HNXXF-LXX-XX-00			•	42 (0.30)	1.10	3.84	5.1				

All ratings typical and at 25°C unless otherwise noted.

- △ An "X" in the Model Number Code indicates an undefined option. Colored letter indicates winding. See Model Number Code on page 39.
- △ See Model Number Code on page 39, optional leaded connectors on page 52 and connection information on page 52.
- △ With rated current applied. Windings at 130°C and motor unmounted and in still air at 40°C (without heat sink).

△ Windings at 130°C and motor in still air at 40°C (without heat sink). Operation of these motors above rated current may cause demagnetization. Contact factory.

△ Small signal inductance as measured with impedance bridge at 1kHz, 1 amp.

△ Thermal resistance measured with motor hanging in still air (unmounted).

POWERMAX II® HYBRIDS

NEMA 23 FRAME (2.3")—Ratings and Characteristics (Con't)

Review the Model Number Code, page 39, to assure that all options are designated. Dimensions, connections and phasing diagrams are on page 49. In addition to those below, motors with characteristics for specific performance requirements are offered. Contact factory for more details.

Rated Currents are in descending order	Motor Model Number Δ	Connection Δ			Holding Torque Δ (2 phases on) oz-in (Nm) $\pm 10\%$	Rated Current/Phase Δ (amps DC)	Phase Resistance (ohms) $\pm 10\%$	Phase Inductance Δ (mH) Typical	Detent Torque oz-in (Nm)	Thermal Resistance Δ (°C/watt)	Rotor Inertia oz-in-S ² (kgm ² x 10 ⁻³)	Weight lbs (kg)
		Parallel	Series	Unipolar								
Torque range: 95-144 oz-in. .67-1.02 Nm	M21NXXA-LXX-XX-00	•			142 (1.00)	5.6	0.23	0.7	↑	↑	↑	↑
	M21NXXA-LXX-XX-00		•		142 (1.00)	2.8	0.92	2.8				
	M21NXXA-LXX-XX-00			•	100 (0.71)	4.0	0.46	0.7				
SIGMAX® M21 Series 1 rotor stack	M21NXXB-LXX-XX-00	•			137 (0.97)	4.6	0.32	1.0	9.4 (0.066)	5.5	0.0017 (0.012)	1.5 (0.68)
	M21NXXB-LXX-XX-00		•		137 (0.97)	2.3	1.28	4.0				
	M21NXXB-LXX-XX-00			•	97 (0.68)	3.3	0.64	1.0				
	M21NXXC-LXX-XX-00	•			144 (1.02)	3.5	0.53	2.0				
	M21NXXC-LXX-XX-00		•		144 (1.02)	1.75	2.12	8.0				
	M21NXXC-LXX-XX-00			•	102 (0.72)	2.5	1.06	2.0				
M21NXXD-LXX-XX-00	M21NXXD-LXX-XX-00	•			135 (0.95)	1.51	2.61	8.7	↓	↓	↓	↓
	M21NXXD-LXX-XX-00		•		135 (0.95)	0.76	10.4	34.8				
	M21NXXD-LXX-XX-00			•	95 (0.67)	1.07	5.22	8.7				
Torque range: 77-116 oz-in. .54-.82 Nm	P21NXXA-LXX-XX-00	•			114 (0.81)	5.6	0.23	0.8	↑	↑	↑	↑
	P21NXXA-LXX-XX-00		•		114 (0.81)	2.8	0.92	3.2				
	P21NXXA-LXX-XX-00			•	81 (0.57)	4.0	0.46	0.8				
STANDARD P21 Series 1 rotor stack	P21NXXB-LXX-XX-00	•			111 (0.79)	4.6	0.32	1.1	4 (0.028)	5.5	0.0017 (0.012)	1.5 (0.68)
	P21NXXB-LXX-XX-00		•		111 (0.79)	2.3	1.28	4.4				
	P21NXXB-LXX-XX-00			•	79 (0.55)	3.3	0.64	1.1				
	P21NXXC-LXX-XX-00	•			116 (0.82)	3.5	0.53	2.3				
	P21NXXC-LXX-XX-00		•		116 (0.82)	1.75	2.12	9.2				
	P21NXXC-LXX-XX-00			•	82 (0.58)	2.5	1.06	2.3				
P21NXXD-LXX-XX-00	P21NXXD-LXX-XX-00	•			109 (0.77)	1.51	2.61	10.3	↓	↓	↓	↓
	P21NXXD-LXX-XX-00		•		109 (0.77)	0.76	10.4	41.2				
	P21NXXD-LXX-XX-00			•	77 (0.54)	1.07	5.22	10.3				

All ratings typical and at 25°C unless otherwise noted.

- Δ An "X" in the Model Number Code indicates an undefined option. Colored letter indicates winding. See Model Number Code on page 39.
- Δ See Model Number Code on page 39, optional leaded connectors on page 52 and connection information on page 52.
- Δ With rated current applied. Windings at 130°C and motor unmounted and in still air at 40°C (without heat sink).

- Δ Windings at 130°C and motor in still air at 40°C (without heat sink). Operation of these motors above rated current may cause demagnetization. Contact factory.
- Δ Small signal inductance as measured with impedance bridge at 1kHz, 1 amp.
- Δ Thermal resistance measured with motor hanging in still air (unmounted).

POWERMAX II® HYBRIDS

NEMA 23 FRAME (2.3")—Ratings and Characteristics (Con't.)

Review the Model Number Code, page 39, to assure that all options are designated. Dimensions, connections and phasing diagrams are on page 49. In addition to those below, motors with characteristics for specific performance requirements are offered. Contact factory for more details.

Motor Model Number [△]	Connection [△]			Holding Torque [△]	Rated Current/Phase [△]	Phase Resistance (ohms) [△]	Phase Inductance [△]	Detent Torque oz-in (Nm)	Thermal Resistance [△] (°C/watt)	Rotor Inertia oz-in-S ² (kgm ² x 10 ⁻³)	Weight lbs (kg)
	Parallel	Series	Unipolar	(2 phases on) oz-in (Nm) ±10%	(amps DC)	±10%	(mH) Typical				
Torque range: 161-253 oz-in. 1.13-1.79 Nm	M22NXXA-LXX-XX-00	•		230 (1.62)	6.5	0.21	0.7	↑ 17 (0.12) ↓	↑ 4.5 ↓	↑ 0.0036 (0.025) ↓	↑ 2.5 (1.13) ↓
	M22NXXA-LXX-XX-00		•	230 (1.62)	3.3	0.84	2.8				
	M22NXXA-LXX-XX-00			163 (1.15)	4.6	0.42	0.7				
SIGMAX® M22 Series 2 rotor stack	M22NXXB-LXX-XX-00	•		253 (1.79)	4.6	0.38	1.7				
	M22NXXB-LXX-XX-00		•	253 (1.79)	2.3	1.52	6.8				
	M22NXXB-LXX-XX-00			179 (1.26)	3.3	0.76	1.7				
	M22NXXC-LXX-XX-00	•		238 (1.68)	3.1	0.78	3.1				
	M22NXXC-LXX-XX-00		•	238 (1.68)	1.55	3.12	12.4				
	M22NXXC-LXX-XX-00			168 (1.19)	2.2	1.56	3.1				
M22NXXD-LXX-XX-00	•		238 (1.68)	2.5	1.22	5.0					
M22NXXD-LXX-XX-00		•	238 (1.68)	1.25	4.88	20.0					
M22NXXD-LXX-XX-00			168 (1.19)	1.77	2.44	5.0					
M22NXXE-LXX-XX-00	•		227 (1.60)	1.64	2.71	10.1					
M22NXXE-LXX-XX-00		•	227 (1.60)	0.82	10.8	40.4					
M22NXXE-LXX-XX-00			161 (1.13)	1.16	5.42	10.1					
Torque range: 138-214 oz-in. .97-1.51 Nm	P22NXXA-LXX-XX-00	•		197 (1.39)	6.5	0.21	0.8	↑ 7 (0.049) ↓	↑ 4.5 ↓	↑ 0.0036 (0.025) ↓	↑ 2.5 (1.13) ↓
	P22NXXA-LXX-XX-00		•	197 (1.39)	3.3	0.84	3.2				
	P22NXXA-LXX-XX-00			139 (0.98)	4.6	0.42	0.8				
STANDARD P22 Series 2 rotor stack	P22NXXB-LXX-XX-00	•		214 (1.51)	4.6	0.38	2.1				
	P22NXXB-LXX-XX-00		•	214 (1.51)	2.3	1.52	8.4				
	P22NXXB-LXX-XX-00			151 (1.07)	3.3	0.76	2.1				
	P22NXXC-LXX-XX-00	•		203 (1.43)	3.1	0.78	3.9				
	P22NXXC-LXX-XX-00		•	203 (1.43)	1.55	3.12	15.6				
	P22NXXC-LXX-XX-00			144 (1.01)	2.2	1.56	3.9				
P22NXXD-LXX-XX-00	•		203 (1.43)	2.5	1.22	6.2					
P22NXXD-LXX-XX-00		•	203 (1.43)	1.25	4.88	24.8					
P22NXXD-LXX-XX-00			144 (1.01)	1.77	2.44	6.2					
P22NXXE-LXX-XX-00	•		195 (1.38)	1.64	2.7	12.6					
P22NXXE-LXX-XX-00		•	195 (1.38)	0.82	10.8	50.4					
P22NXXE-LXX-XX-00			138 (0.97)	1.16	5.4	12.6					

All ratings typical and at 25°C unless otherwise noted.

△ An "X" in the Model Number Code indicates an undefined option. Colored letter indicates winding. See Model Number Code on page 39.

△ See Model Number Code on page 39 optional leaded connectors on page 52 and connection information on page 52.

△ With rated current applied. Windings at 130°C and motor unmounted and in still air at 40°C (without heat sink).

△ Windings at 130°C and motor in still air at 40°C (without heat sink). Operation of these motors above rated current may cause demagnetization. Contact factory.

△ Small signal inductance as measured with impedance bridge at 1kHz, 1 amp.

△ Thermal resistance measured with motor hanging in still air (unmounted).

POWERMAX II®

HYBRIDS WITH LOW INERTIA ROTORS

ROTOR INERTIA CHARACTERISTICS . . . POWERMAX II® motors

Single and double stack POWERMAX II® motors are available with both standard and low inertia rotors. Choose low inertia to produce the highest acceleration rates possible.

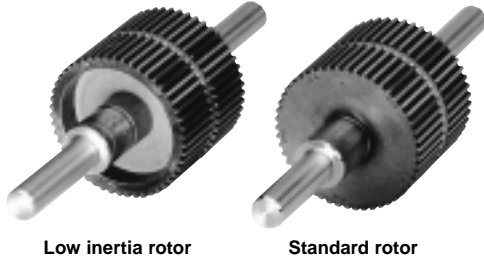

ACCELERATION COMPARISON

	Model	Rotor Type	△ Inertia oz-in-S ² x 10 ⁻³ / kgm ² x 10 ⁻³	Theoretical Normalized △ Acceleration comparison
Single Stack	P21NRXX-L	Standard	1.68/0.010	1
	P21NRXX-J	Low inertia	1.30/0.008	1.27
	M21NRXX-L	Standard	1.68/0.010	1.23
	M21NRXX-J	Low inertia	1.30/0.008	1.59
Double Stack	P22NRXX-L	Standard	3.57/0.022	1
	P22NRXX-J	Low inertia	2.59/0.016	1.30
	M22NRXX-L	Standard	3.57/0.022	1.18
	M22NRXX-J	Low inertia	2.59/0.016	1.63

△ Low inertia rotors not offered for half stack models

△ Comparative values for normalized acceleration of unloaded motors. Base value is standard hybrid motor with standard rotor, indicated for single and double stack lengths.

Actual acceleration capability depends on load, velocity profile and driver power. Comparisons made with 90°C temperature rise using bipolar driver.

NEMA 23 FRAME (2.3")—Ratings and Characteristics

Review the Model Number Code, page 39, to assure that all options are designated. Dimensions, connections and phasing diagrams start on page 49. In addition to those below, all 1 and 2 stack "L" construction windings, page 59, and custom windings for specific performance requirements are available with low inertia rotors. Contact factory for more details.

Motor Model Number △	Connection △			Holding Torque △ (2 phases on) oz-in (Nm) ±10%	Rated Current/ Phase △ (amps DC)	Phase Resistance (ohms) ±10%	Phase Inductance △		Detent Torque oz-in (Nm)	Thermal Resistance △ (°C/watt)	Rotor Inertia oz-in-S ² (kgm ² x 10 ⁻³)	Weight lbs (kg)
	Parallel	Series	Unipolar				(mH) Typical					
Torque range: 99-140 oz-in. .70-.99 Nm												
M21NXXA-JXX-XX-00	•			140 (0.99)	5.6	0.23	0.7		9.4	↑	↑	↑
M21NXXA-JXX-XX-00	•			140 (0.99)	2.8	0.92	2.8					
M21NXXA-JXX-XX-00		•		99 (0.70)	4.0	0.46	0.7	(0.066)				
SIGMAX® M21 Series 1 rotor stack												
Torque range: 79-111 oz-in. .55-.78 Nm												
P21NXXA-JXX-XX-00	•			111 (0.78)	5.6	0.23	0.9		4	↓	↓	↓
P21NXXA-JXX-XX-00	•			111 (0.78)	2.8	0.92	3.6					
P21NXXA-JXX-XX-00		•		79 (0.55)	4.0	0.46	0.9	(0.028)				
STANDARD P21Series 1 rotor stack												
Torque range: 178-252 oz-in. 1.26-1.78 Nm												
M22NXXB-JXX-XX-00	•			252 (1.78)	4.6	0.38	1.5		17	↑	↑	↑
M22NXXB-JXX-XX-00	•			252 (1.78)	2.3	1.52	6.0					
M22NXXB-JXX-XX-00		•		178 (1.26)	3.3	0.76	1.5	(0.12)				
SIGMAX® M22 Series 2 rotor stack												
Torque range: 142-201 oz-in. 1.00-1.42 Nm												
P22NXXB-JXX-XX-00	•			201 (1.42)	4.6	0.38	1.8		7	↓	↓	↓
P22NXXB-JXX-XX-00	•			201 (1.42)	2.3	1.52	7.2					
P22NXXB-JXX-XX-00		•		142 (1.00)	3.3	0.76	1.8	(0.049)				
STANDARD P22 Series 2 rotor stack												

All ratings typical and at 25°C unless otherwise noted.

△ An "X" in the Model Number Code indicates an undefined option. Colored letter indicates winding. See Model Number Code on page 39.

△ See Model Number Code on page 39, optional leaded connectors on page 52 and connection information on page 52.

△ With rated current applied. Windings at 130°C and motor unmounted and in still air at 40°C (without heat sink).

△ Windings at 130°C and motor in still air at 40°C (without heat sink). Operation of these motors above rated current may cause demagnetization. Contact factory

△ Small signal inductance as measured with impedance bridge at 1kHz, 1 amp.

△ Thermal resistance measured with motor hanging in still air (unmounted).

DIMENSIONS... (POWERMAX II® HYBRIDS) $\frac{\text{in.}}{\text{mm}}$ (metric dim. for ref. only)

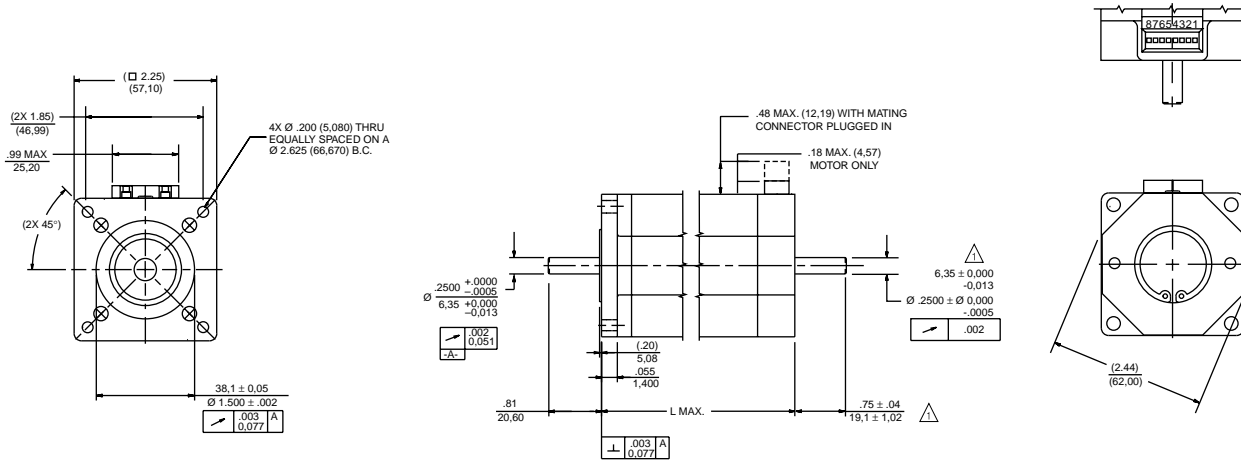

Motor Model	L Max.
P2H	1.60 40,7
P or M21	2.06 52,3
P or M22	3.10 78,7

STANDARD SHAFT OPTIONS

1. Shaft modifications also available. See page 39.
2. Optional flat available on front shaft as shown.

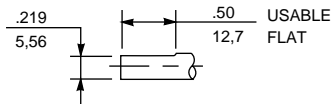

△ Optional rear shaft extension available as shown. Same diameter as front shaft extension.

ENCODER OPTION

See page 53 for encoder/mounting specifications.

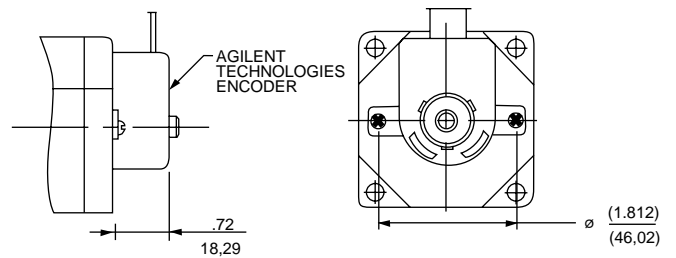

CONNECTION INFORMATION... Terminations and phase sequencing

NOTE: Phase sequencing direction of rotation as viewed from mounting end of motor.

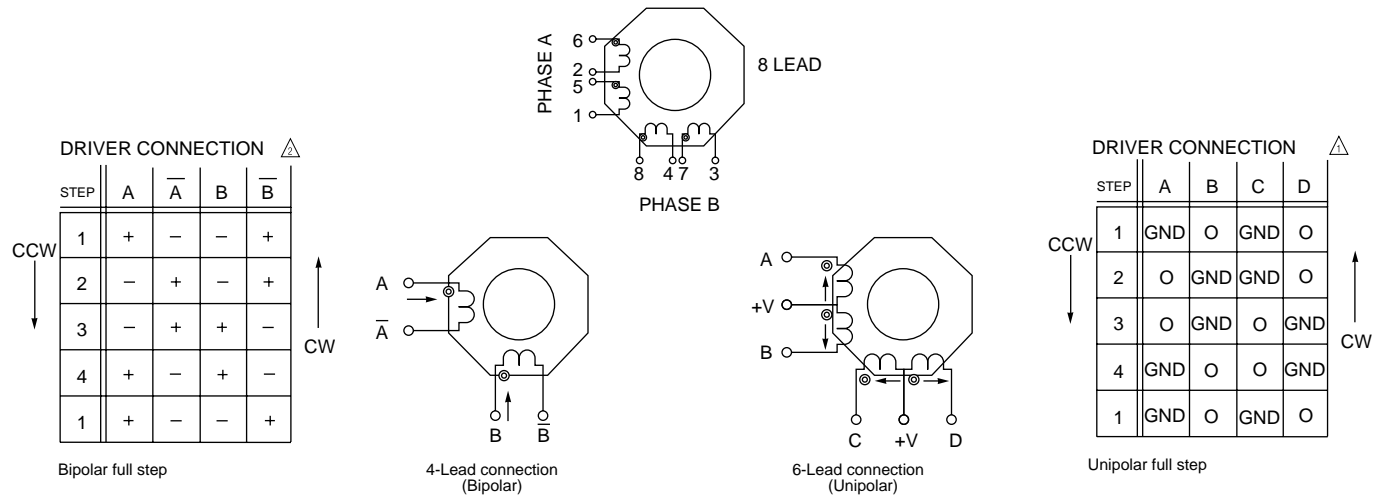

△ Notes:

- 0 = off or open
- + = positive current flow
- = negative current flow
- GND = ground

POWERMAX II® Flying Lead Motor Connection Informations

CONNECTION	LEAD COLOR	DRIVER CONNECTION
4-LEAD BIPOLAR	BLK	A
BIPOLAR	ORG	\bar{A}
SERIES	RED	B
	YEL	\bar{B}
	WHT/BLK & WHT/ORG	—
	WHT/RED & WHT/YE	—
	WHT/RED & WHT/YEL	—
4-LEAD BIPOLAR	BLK & WHT/ORG	\bar{A}
BIPOLAR	ORG & WHT/BLK	A
PARALLEL	RED & WHT/YEL	\bar{B}
	YEL & WHT/RED	B
6-LEAD UNIPOLAR	BLK	A
UNIPOLAR	ORG	B
	RED	C
	YEL	D
	WHT/BLK & WHT/ORG	+V
	WHT/RED & WHT/YEL	+V

CONNECTION INFORMATION . . . Terminations and phase sequencing

NOTE: Phase sequencing direction of rotation as viewed from mounting end of motor.

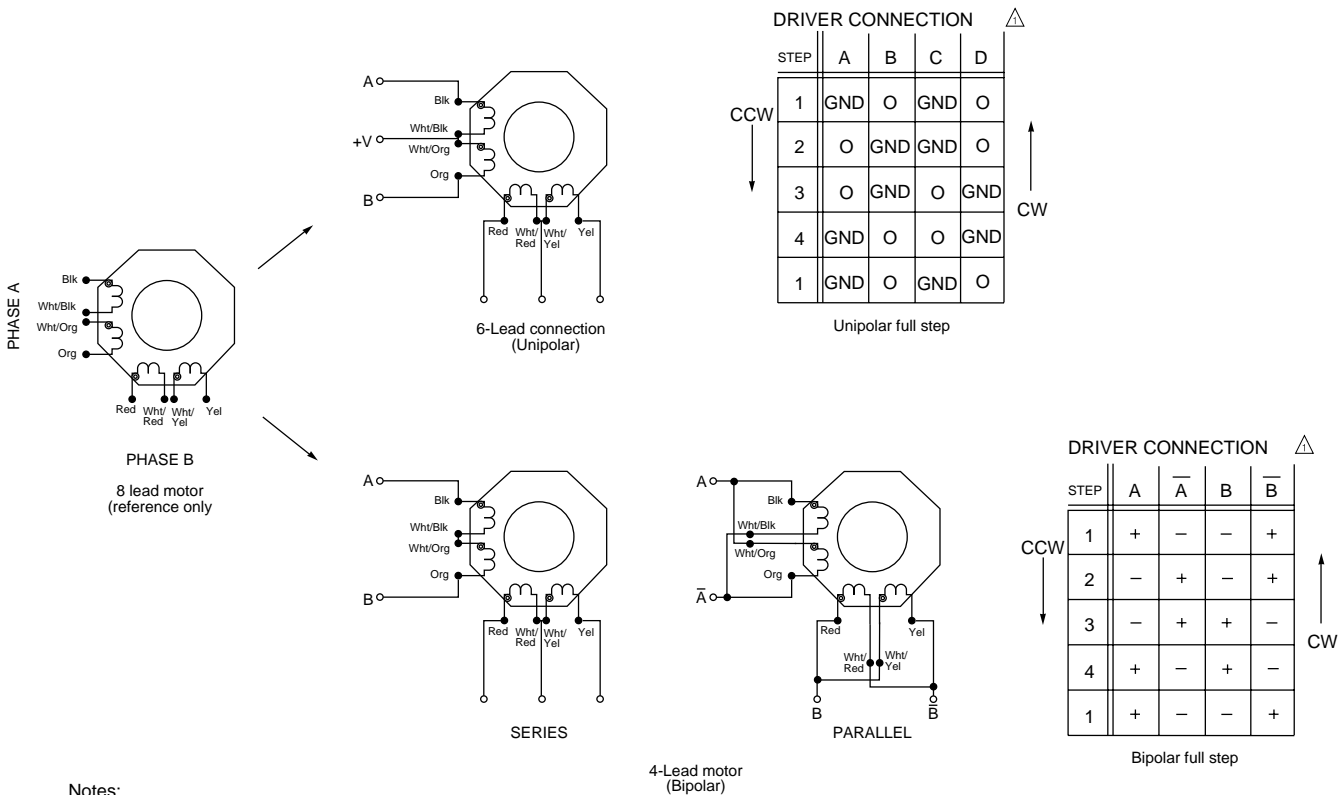

Notes:

- △ 0 = off or open
- + = positive current flow
- = negative current flow
- GND = ground

POWERMAX II® CONNECTION INFORMATION . . .

. . . Optional leaded connectors

Four different leaded connectors are available from Pacific Scientific. Order the "GW" part number as a separate item.

Part Number	Phase Connection	Pin No.	Connector/Leadwire Assembly Lead Colors	Driver Connection
GW0000F (8 Lead)	bipolar series	6	Black	A
		1	Orange	\bar{A}
		8	Red	B
		3	Yellow	\bar{B}
		2 & 5	Wht/Blk & Wht/Org	none
		4 & 7	Wht/Red & Wht/Yel	none
	bipolar parallel	6 & 5	Blk & Wht/Org	A
		1 & 2	Org & Wht/Blk	\bar{A}
		8 & 7	Red & Wht/Yel	B
		3 & 4	Yel & Wht/Red	\bar{B}
	unipolar	6	Black	A
		1	Orange	B
		8	Red	C
		3	Yellow	D
		2 & 5	Wht/Blk & Wht/Org	+ V
		4 & 7	Wht/Red & Wht/Yel	+ V
GW0000E (6 Lead)	unipolar	6	Black	A
		1	Orange	B
		8	Red	C
		3	Yellow	D
		2 & 5	Wht/Blk & Org	+ V
		4 & 7	Wht/Red & Yel	+ V
		GW0000H (4 Lead)	bipolar parallel	6 & 5
1 & 2	Orange			\bar{A}
8 & 7	Red			B
3 & 4	Yellow			\bar{B}
GW0000L (4 Lead)	bipolar series	6	Black	A
		1	Orange	\bar{A}
		8	Red	B
		3	Yellow	\bar{B}

Typical leaded connector (4-lead shown)

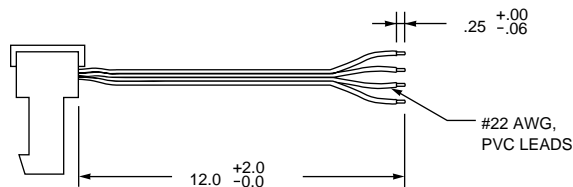

. . . Optional mating connector only

A separate mating connector housing and strain relief cover are available from Pacific Scientific or AMP. The user attaches leads to the connector.

ITEM	PACIFIC SCIENTIFIC	AMP
STANDARD HOUSING	GP00012	641653-8
STANDARD COVER	GP00013	643077-8

Optional Ground Wire

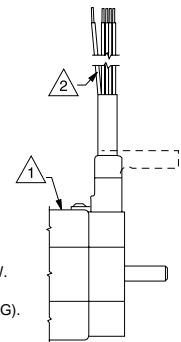

NOTES:

- GROUND LABEL PLACED IN FRONT OF GROUND SCREW.
- GREEN/YELLOW SAFETY EARTH CONDUCTOR (18AWG).

See page 39 for ordering information.

ENCODER OPTIONS

NEMA 23 ENCODER OPTION

The standard encoder offered on the NEMA 23 motor is the Agilent Technologies HEDS 5600 series.

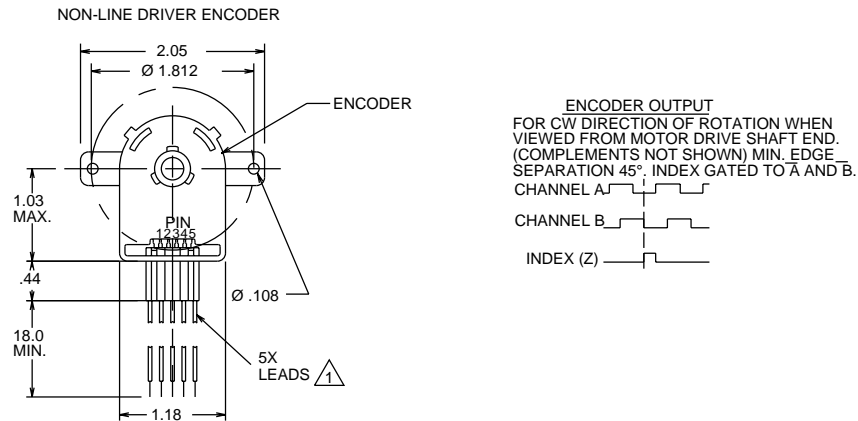

PIN	COLOR	FUNCTION
1	BLACK	GROUND
2	BLUE	Z
3	WHITE	A
4	RED	+5V
5	BROWN	B

PARAMETERS Δ	NON-LINE DRIVER	
	INCREMENTAL	
ENCODER OPTION	HD	HJ
PULSES PER REVOLUTION	500	512
SUPPLY VOLTAGE	+5V \pm 10% @ 85 mA MAX.	
OUTPUT FORMAT	DUAL CHANNEL QUADRATURE AND INDEX	
OUTPUT TYPE	SQUARE WAVE TTL COMPATIBLE	
FREQUENCY RESPONSE:		
DATA	100 kHz	
INDEX	100 kHz	
ROTOR INERTIA	5×10^{-7} lb-in-S ²	
WEIGHT	0.08 lb.	

ENCODER MOUNTING PROVISION ONLY = M1

FOR AGILENT TECHNOLOGIES HEDS 5600 SERIES OR SIMILAR.

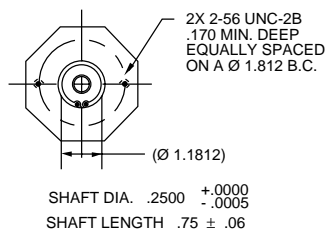

NOTES:

- Δ Leads are terminated with Agilent Technologies HEDS-8903 connector.
- Δ TYPICAL @ 25° C