

# MECHATRONICS

## 3 AND 4 AXIS MICRO STEPPER MOTOR DRIVER DATASHEET

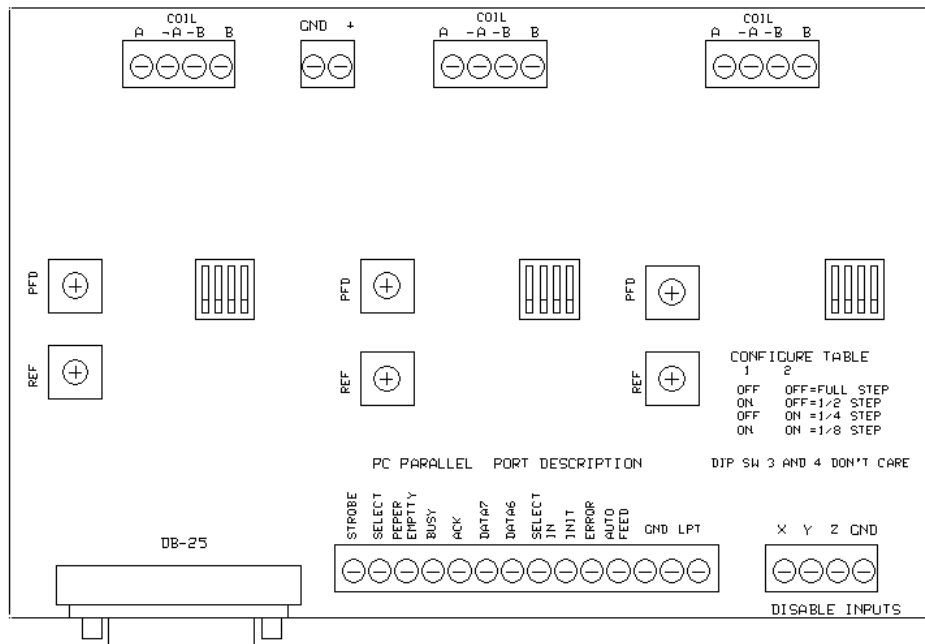

### FEATURES

- Two phases bipolar driver (PWM Technology)
- Resolution: Full 1/2, 1/4, 1/8, selectable via DIP switch per axis, you can get 1600 steps per revolution with 1.8° common stepper motor.
- Individual axis enable/disable via optocoupler input terminal (it can be used as limit axis switch)
- Adjustable stepper motor current via potentiometer on board
- Adjustable PFD (Percent Fast Decay)
- DB25 male connector on board for PC Parallel port
- All inputs signals are optocoupled for PC Parallel port protection
- Full access to all unused DB25 port pins via terminal block
- 24VDC input voltage
- Individual heatsink per axis
- 4 Wire, 6 Wire and 8 Wire (NEMA17, NEMA23 and NEMA34) stepper motors can be used with stepper motor driver
- Fuse per axis integrated for driver board protection
- 2.5 AMPS/PHASE per axis

## PARALLEL PORT CONNECTION TO DRIVER BOARD

A DB25 male-female extension should be used to interconnect the driver board to your PC; this connection should have no any kind of adapters, no hubs.

If your computer is a laptop it is probably you don't have access to a parallel port, if that is the case you must install a PCMCIA parallel port card. The DB25 connector pin description of the driver board is the following:

DB25 CONNECTOR PIN NUMBER	USE IN DRIVER BOARD	USE IN PROTOTYPING TERMINAL BLOCK
1		Strobe
2	Step X	
3	Dir X	
4	Step Y	
5	Dir Y	
6	Step Z	
7	Dir Z	
8	Step A (available only in 4 axis board)	Data 6 (available only in 3 axis board)
9	Dir A (available only in 4 axis board)	Data 7 (available only in 3 axis board)
10		ACK
11		Busy
12		Paper empty
13		Select
14		Auto Feed
15		Error
16		Init
17		Select in
18-to-25	Ground for Step and Dir	LPT Ground

## DIP SWITCH RESOLUTION SELECTION

The dip switch on board is used in the driver step resolution configuration. i.e., If you have a 1.8° stepper motor and select full step, you will get 200 steps each 360° turn, with a 1/8 step resolution you will get 1600 steps each 360° turn.

You can change the step resolution when the power is ON or OFF without fear of risk the driver board.

Resolution	DIP SWITCH POSITION		Steps number per 360° turn
	1	2	
Full step	OFF	OFF	200
1/2 step	ON	OFF	400
1/4 step	OFF	ON	800
1/8 step	ON	ON	1600

## BASIC SCHEMATICS OF STEPPER MOTOR

### 4 WIRE STEPPER MOTOR DIAGRAM

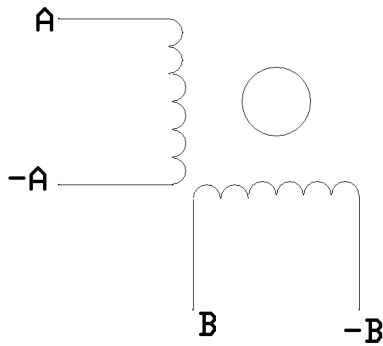

Connect each wire to the terminal block as shows you. i.e., The **-B** wire of the stepper motor must be connected to the **-B** screw in the terminal block.

### 6 WIRE STEPPER MOTOR DIAGRAM (SERIES WIRING)

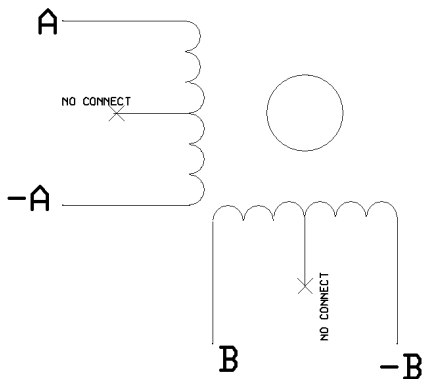

Do not connect the middle wire of each coil; don't forget to insulate the connection and the middle wire.

Connect each wire to the terminal block as shows you. i.e., The **-B** wire of the stepper motor must be connected to the **-B** screw in the terminal block.

### 8 WIRE STEPPER MOTOR DIAGRAM (SERIES WIRING)

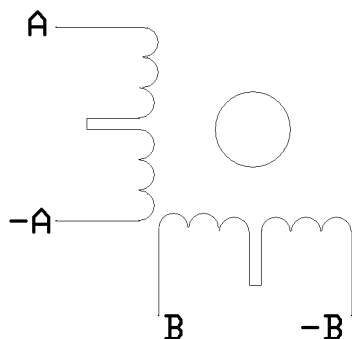

Both centre wires of each coil must be connected; don't forget to insulate the connections.

Connect each wire to the terminal block as shows you. i.e., The **-B** wire of the stepper motor must be connected to the **-B** screw in the terminal block.

It is suggested you must have the diagram of the stepper motor that you are going to use, this helps you to avoid short circuits, damage the board or something similar.

Don't worry if you have not the diagram, you can get the properly configuration with a multimeter, in the ohm section, take a wire as reference, then, measure the resistance between this and the other wires, when you get a smaller resistance (less than 10 ohm) you have found a coil (Most of the stepper motors has a resistance lower than 10 ohm per coil).

## ADJUSTMENT OF THE STEPPER MOTOR CURRENT

**DO NOT CONNECT OR DISCONNECT ANY MOTORS OR ANY MOTOR'S WIRE WHILE POWER IS ON, THE DRIVER BOARD CAN BE DAMAGED IMMEDIATELY**

Every axis current must be adjusted in the V-REF potentiometer using a multimeter in the volts section otherwise use a voltmeter; connect the black test probe to the power supply GND, the red test probe to the Test Point 1 (TP1), adjust the potentiometer until you get the desired current. Follow this formula:

$$V_{REF} = 2 * (\text{desired current})$$

i.e., For a desired current of 1.8 Amp you will adjust the V-REF potentiometer until you get 3.6VDC in the voltmeter.

There is no problem if you adjust the V-REF potentiometer when the power is on and the stepper motor is connected to the board, just be sure that current increase slowly. If you realize an overheating in the motor it means that the motor's current is high.

**NOTE: THE MAXIMUM VOLTAGE FOR VREF IS 5.0VDC PER AXIS**

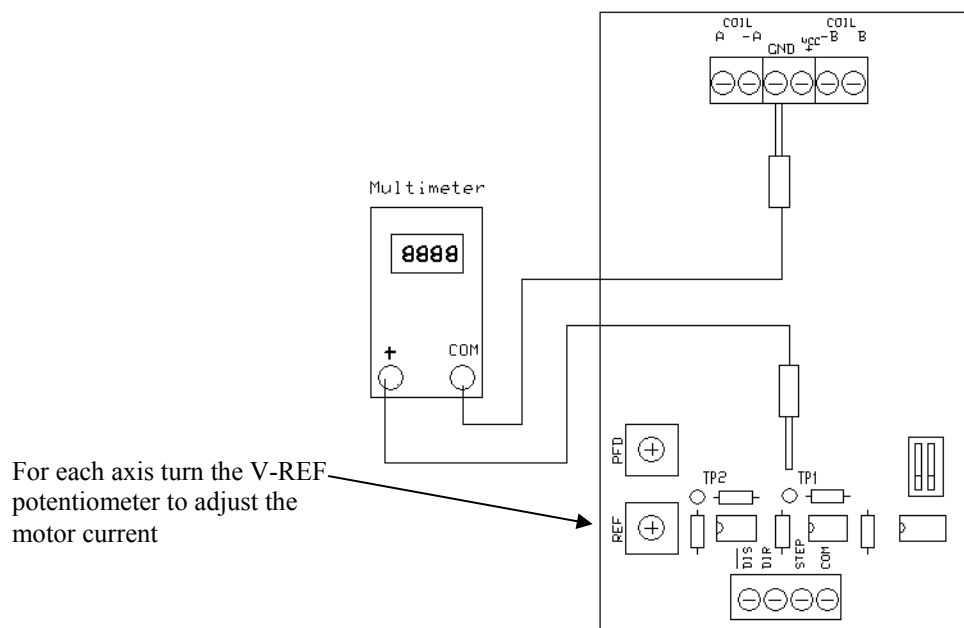

If you use 6 or 8 wire motor use the series wiring, it reduces the amperage rating in 50%. i.e., A 3Amp motor wired in this way should be considered as 1.5Amp motor.

Every axis can give you 2.5Amp per phase. If your application doesn't need the 100% of the torque you can adjust the current to a conservative value (70-80%), this can give you good results without needing a fan cooling.

## ADJUSTMENT OF PFD VOLTAGE

The voltage in TP2 is adjusted by the PFD (Percent Fast Decay) potentiometer, this voltage tells the driver the output current decay, when the PWM circuit switches the control current, you can adjust the PFD voltage value in order to decrease the resonance noise in the stepper motor.

It is normal that you hear a little resonance noise in the motors, this is caused by the current pulse control, in fact, it is imperceptible in high quality motors. For most of these stepper motors a PFD = 2.5VDC is a good reference to make any adjustment.

There is no any risk of damage if you adjust the PFD voltage when the power is on and the stepper motor is connected to the board.

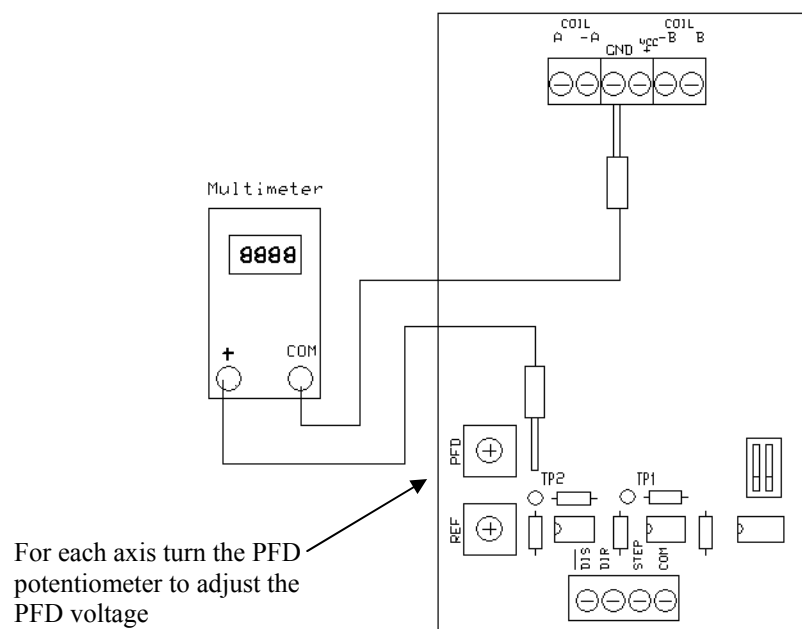

## WARNING

- **DOUBLE CHECK ALL CONNECTIONS BEFORE TO CONNECT TO POWER SUPPLY, THEN, TURN ON THE POWER SUPPLY**
- **DO NOT CONNECT OR DISCONNECT ANY MOTOR OR ANY MOTOR'S WIRE WHILE POWER IS ON, THE DRIVER BOARD CAN BE DAMAGED IMMEDIATELY**
- **RECOMMENDED POWER SUPPLY:  
24VDC@7A FOR 3 AXIS BOARD  
24VDC@10A FOR 4 AXIS BOARD**
- **MINIMUM POWER SUPPLY:  
12VDC@7A FOR 3 AXIS BOARD  
12VDC@10A FOR 4 AXIS BOARD**
- **MAXIMUM POWER SUPPLY:  
32VDC@7A FOR 3 AXIS BOARD  
32VDC@10A FOR 4 AXIS BOARD**
- **RECOMMENDED FUSE 2.5AMP MAX.**
- **LTP GND AND POWER SUPPLY GND ARE INDEPENDENT, FOR ANY REASON THESE TERMINALS SHOULD NOT BE INTERCONNECTED**

## BASIC CONNECTION

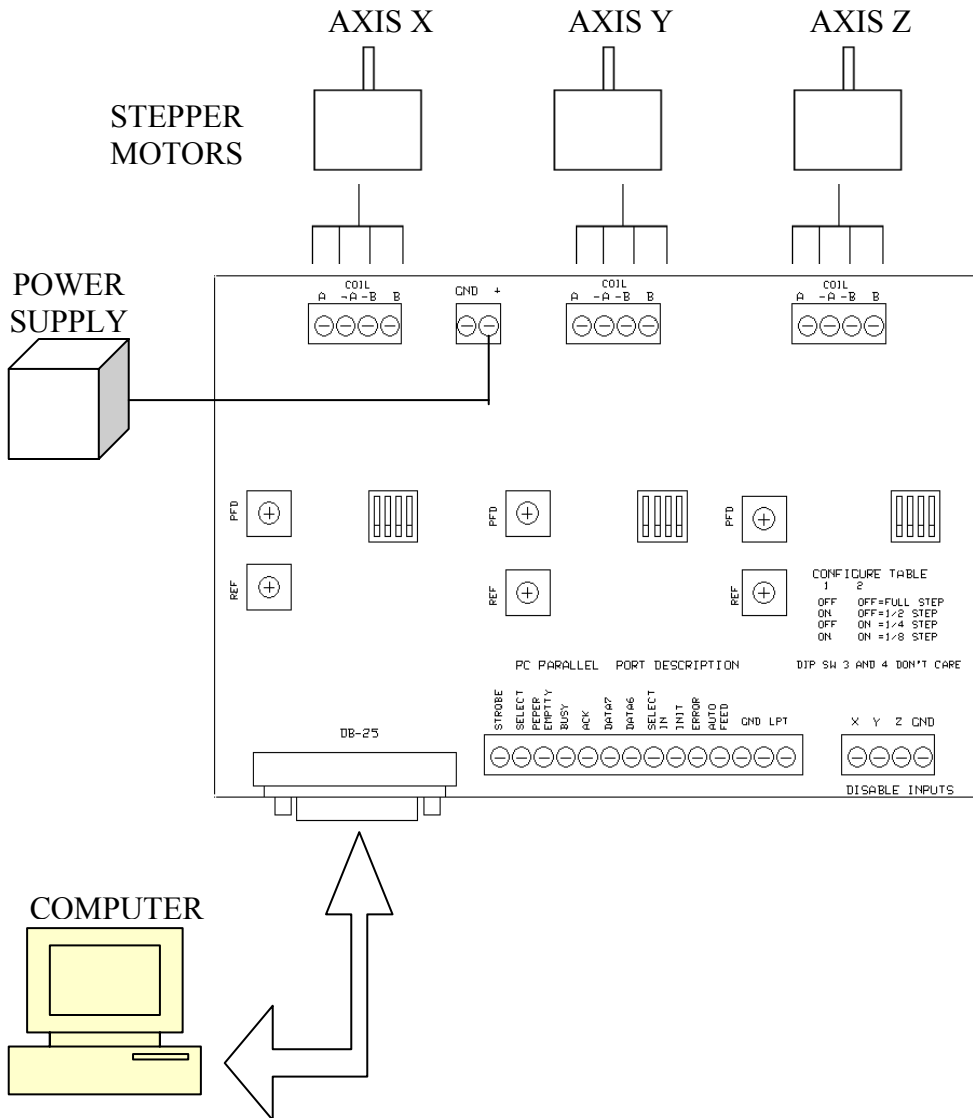

## LIMIT SWITCH CONNECTIONS

The limit switches are used to disable the electrical current in the stepper motor, avoiding incidental damages in the mechanical axes; you can wire them each one to a mechanical switch in you machine.

They are placed in both extreme of each axis, if the mechanical system active one of these switches the corresponding motor will be automatically disabled, you need to deactivate the switch to move again the motor.

**Note: The power supply GND disable the limit switches, for any reason this terminal should not be interconnected to the LPT GND.**

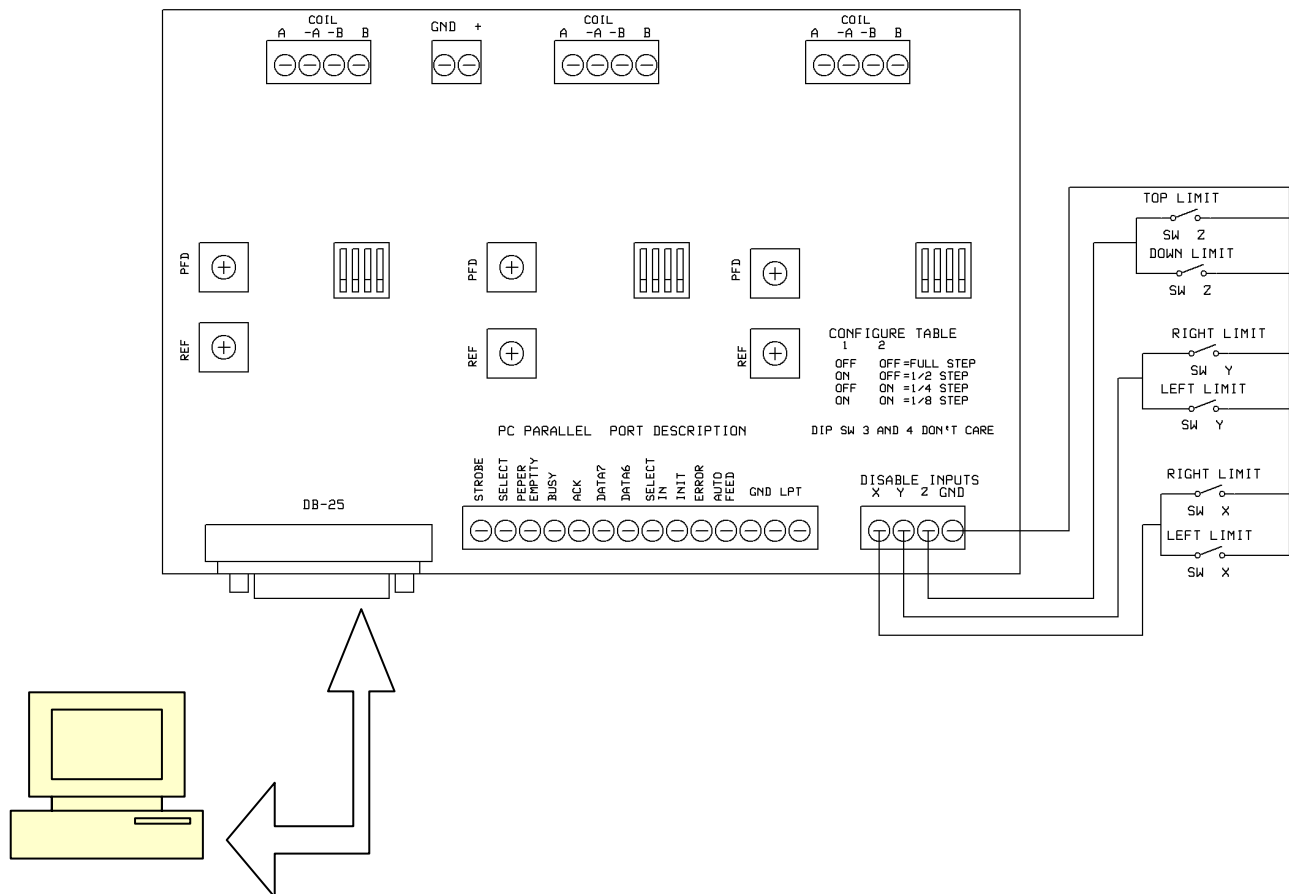



## ADDITIONAL SINGLE AXIS DRIVER

The single axis board works exactly as the 3 axis board driver, the control signals (DIR and STEP) must be wired to the DB25 breakout terminal and configure your CAM software.

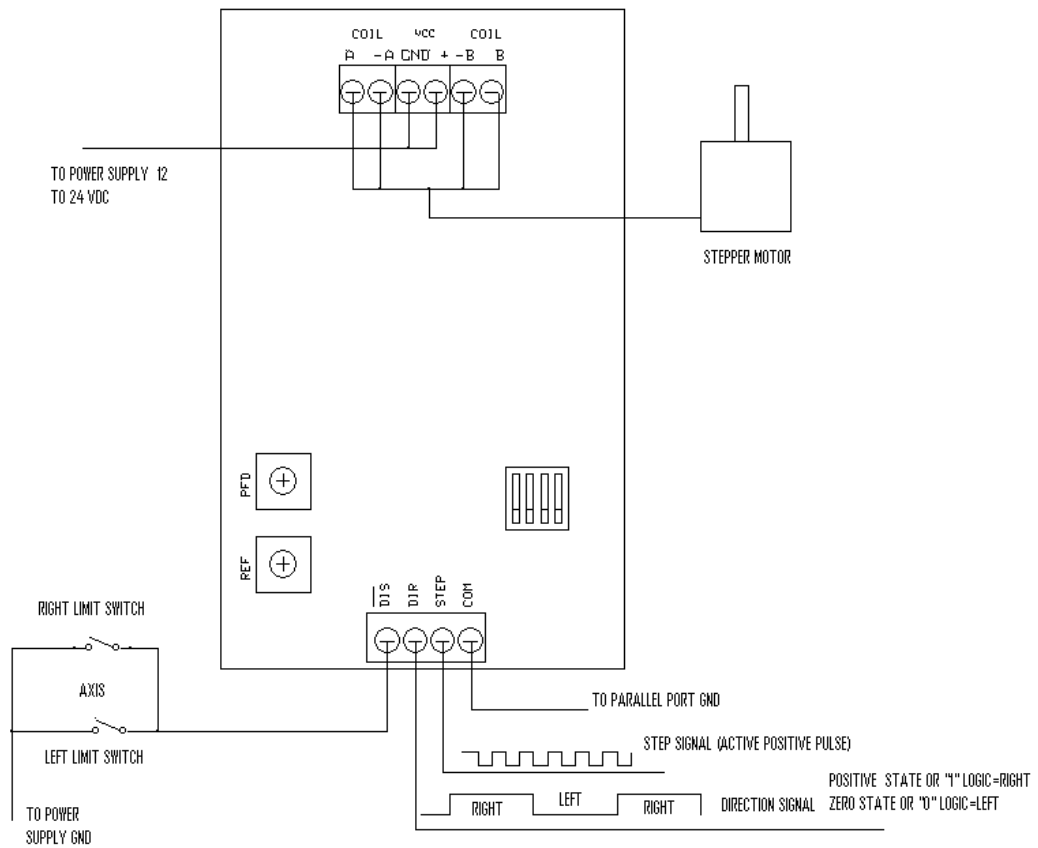

**Note: LPT GND and power supply GND are independent, for any reason these terminals should not be interconnected, otherwise, the parallel port protection doesn't work properly.**

## CONNECTING THE 4<sup>TH</sup> OR "A" AXIS

You can add a fourth axis to your system, is it common called "A" axis, this extra axis works exactly and has the same features than the 3 axis board driver the control signals (DIR and STEP) must be wired to the DB25 breakout terminal and configure your CAM software.

The COM signal of the single axis board must be wired to the LPT GND of the 3 axis board. A pair of limit switches must be wired to the DIS (Disable Current Axis) signal of the single axis board.

You should wire the DIR and STEP signal to some of the following parallel port pins: 1, 9, 8, 14, 16 or 17. Whichever the pins you have choose remember to configure them in your favourite CAM software. Be aware that the following parallel port pins: 10, 11, 12, 13 and 15 are used **ONLY** as input parallel port signals.

