

Stepping Motor Drives

The stepper drive delivers electrical power to the motor in response to low-level signals from the control system.

The motor is a torque-producing device, and this torque is generated by the interaction of magnetic fields. The driving force behind the stator field is the magneto-motive force (MMF), which is proportional to current and to the number of turns in the winding. This is often referred to as the amp-turns product. Essentially, the drive must act as a source of current. The applied voltage is only significant as a means of controlling the current.

Input signals to the stepper drive consist of step pulses and a direction signal. One step pulse is required for every step the motor is to take. This is true regardless of the stepping mode. So the drive may require 200 to 101,600 pulses to produce one revolution of the shaft. The most commonly-used stepping mode in industrial applications is the half-step mode in which the motor performs 400 steps per revolution. At a shaft speed of 1800 rpm, this corresponds to a step pulse frequency of 20kHz. The same shaft speed at 25,000 steps per rev requires a step frequency of 750 kHz, so motion controllers controlling microstep drives must be able to output a much higher step frequency.

Fig. 2.1 Stepper drive elements

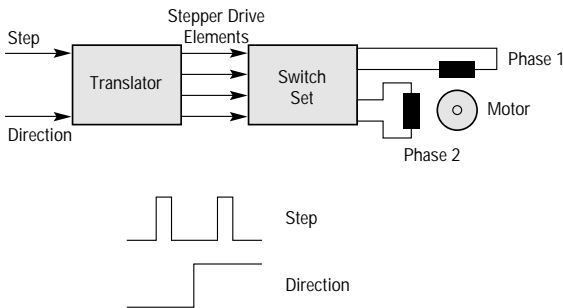

The logic section of the stepper drive is often referred to as the translator. Its function is to translate the step and direction signals into control waveforms for the switch set (see Fig. 2.1). The basic translator functions are common to most drive types, although the translator is necessarily more complex in the case of a microstepping drive. However, the design of the switch set is the prime factor in determining drive performance, so we will look at this in more detail.

The simplest type of switch set is the unipolar arrangement shown in Fig. 2.2. It is referred to as a unipolar drive because current can only flow in one direction through any particular motor terminal. A bifilar-wound motor must be used since reversal of the stator field is achieved by transferring current to the second coil. In the case of this very simple drive, the current is determined only by the motor winding resistance and the applied voltage.

Fig. 2.2 Basic unipolar drive

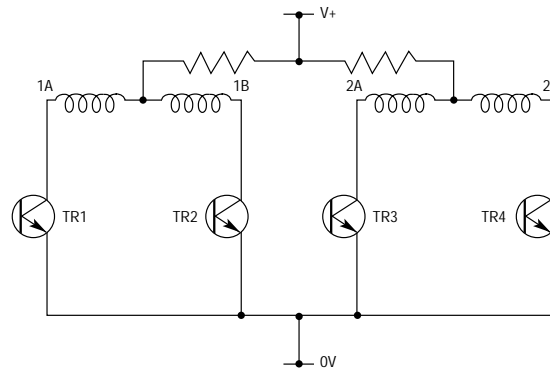

Such a drive will function perfectly well at low stepping rates, but as speed is increased, the torque will fall off rapidly due to the inductance of the windings.

Inductance/Water Analogy

For those not familiar with the property of inductance, the following water analogy may be useful (Fig. 2.3). An inductor behaves in the same way as a turbine connected to a flywheel. When the tap is turned on and pressure is applied to the inlet pipe, the turbine will take time to accelerate due to the inertia of the flywheel. The only way to increase

the acceleration rate is to increase the applied pressure. If there is no friction or leakage loss in the system, acceleration will continue indefinitely for as long as the pressure is applied. In a practical case, the final speed will be determined by the applied pressure and by friction and the leakage past the turbine blades.

Fig. 2.3 Inductance water analogy

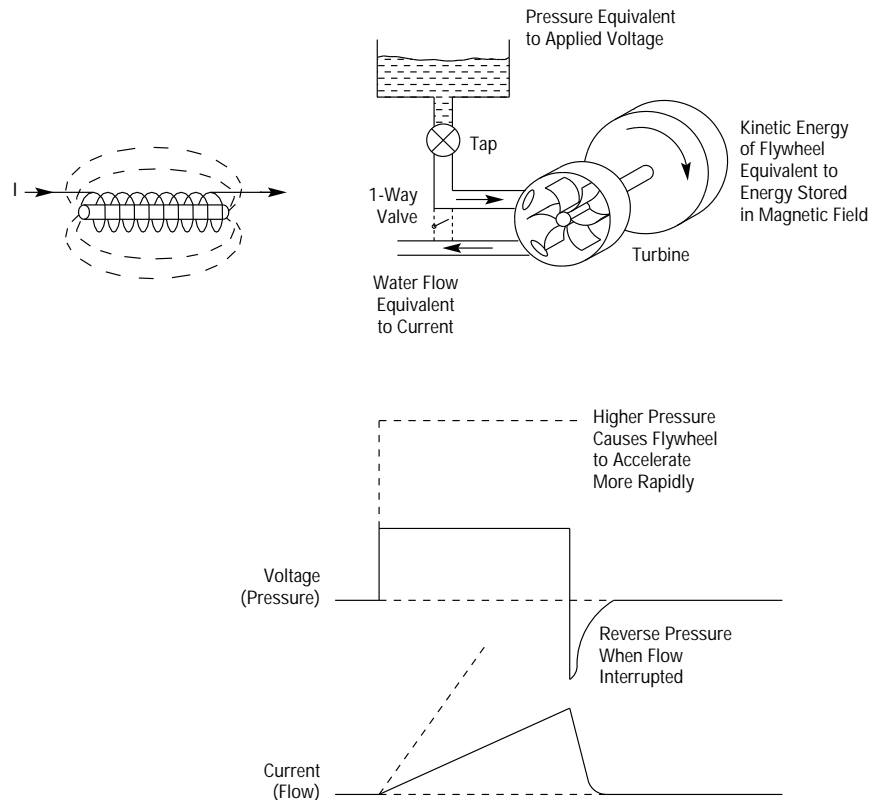

Applying a voltage to the terminals of an inductor produces a similar effect. With a pure inductance (i.e., no resistance), the current will rise in a linear fashion for as long as the voltage is applied. The rate of rise of current depends on the inductance and the applied voltage, so a higher voltage must be applied to get the current to rise more quickly. In a practical inductor possessing resistance, the final current is determined by the resistance and the applied voltage.

Once the turbine has been accelerated up to speed, stopping it again is not a simple matter. The kinetic energy of the flywheel has to be dissipated, and as soon as the tap is turned off, the flywheel drives the turbine like a pump and tries to keep the water flowing. This will set up a high pressure across the inlet and outlet pipes in the reverse direction. The equivalent energy store in the inductor is the magnetic field. As this field collapses, it tries to maintain the current flow by generating a high reverse voltage.

By including a one-way valve across the turbine connections, the water is allowed to continue circulating when the tap is turned off. The energy stored in the flywheel is now put to good use in maintaining the flow. We use the same idea in the recirculating chopper drive, in which a diode allows the current to recirculate after it has built up.

Going back to our simple unipolar drive, if we look at the way the current builds up (Fig. 2.4) we can see that it follows an exponential shape with its final value set by the voltage and the winding resistance. To get it to build up more rapidly, we could increase the applied voltage, but this would also increase the final current level. A simple way to alleviate this problem is to add a resistor in series with the motor to keep the current the same as before.

R-L Drive

The principle described in the Inductance/Water Analogy (p. A24) is applied in the resistance-limited (R-L) drive see Fig. 2.4. Using an applied voltage of 10 times the rated motor voltage, the current will reach its final value in one tenth of the time. If you like to think in terms of the electrical time constant, this has been reduced from L/R to $L/10R$, so we'll get a useful increase in speed. However we're paying a price for this extra performance. Under steady-state conditions, there is 9 times as much power dissipated in the series resistor as in the motor itself, producing a significant amount of heat. Furthermore, the extra power must all come from the DC power supply, so this must be much larger. R-L drives are therefore only suited to low-power applications, but they do offer the benefits of simplicity, robustness and low radiated interference.

Fig. 2.4 Principle of the R-L drive

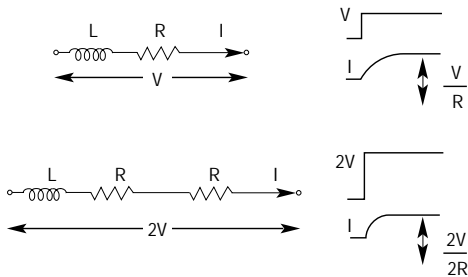

Unipolar Drive

Fig. 2.5 Basic unipolar drive

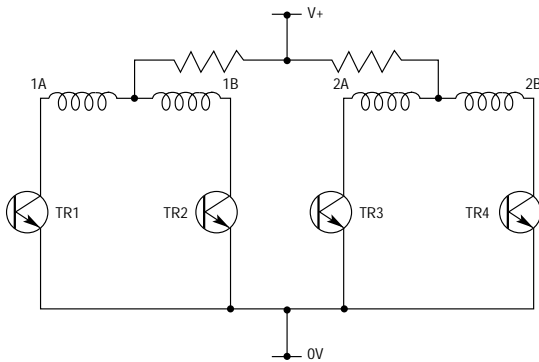

A drawback of the unipolar drive is its inability to utilize all the coils on the motor. At any one time, there will only be current flowing in one half of each winding. If we could utilize both sections at the same time, we could get a 40% increase in amp-turns for the same power dissipation in the motor.

To achieve high performance and high efficiency, we need a bipolar drive (one that can drive current in either direction through each motor coil) and a better method of current control. Let's look first at how we can make a bipolar drive.

Bipolar Drive

An obvious possibility is the simple circuit shown in Fig. 2.6, in which two power supplies are used together with a pair of switching transistors. Current can be made to flow in either direction through the motor coil by turning on one transistor or the other. However, there are distinct drawbacks to this scheme. First, we need two power supplies, both of which must be capable of delivering the total current for both motor phases. When all the current is coming from one supply the other is doing nothing at all, so the power supply utilization is poor. Second, the transistors must be rated at double the voltage that can be applied across the motor, requiring the use of costly components.

Fig. 2.6 Simple bipolar drive

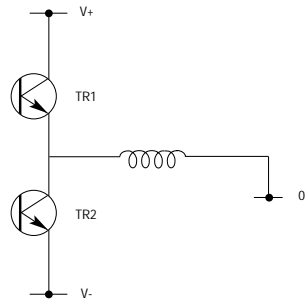

The standard arrangement used in bipolar motor drives is the bridge system shown in Fig. 2.7. Although this uses an extra pair of switching transistors, the problems associated with the previous configuration are overcome. Only one power supply is needed and this is fully utilized; transistor voltage ratings are the same as that available for driving the motor. In low-power systems, this arrangement can still be used with resistance limiting as shown in Fig. 2.8.

Fig. 2.7 Bipolar bridge

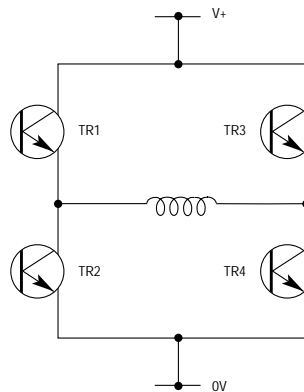
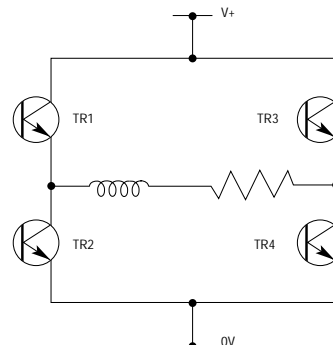

Fig. 2.8 Bipolar R-L drive



Recirculating Chopper Drive

The method of current control used in most stepper drives is the recirculating chopper (Fig. 2.9). This approach incorporates the four-transistor bridge, recirculation diodes, and a sense resistor. The resistor is of low value (typically 0.1 ohm) and provides a feedback voltage proportional to the current in the motor.

Fig. 2.9 Recirculating chopper drive

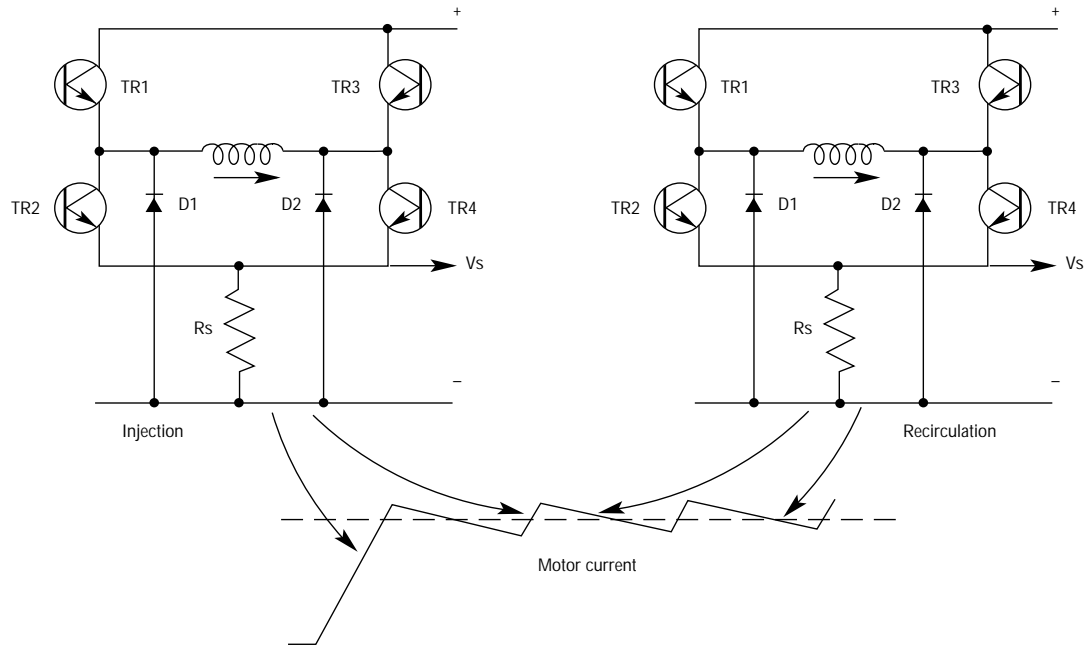

Current is injected into the winding by turning on one top switch and one bottom switch, and this applies the full supply voltage across the motor. Current will rise in an almost linear fashion and we can monitor this current by looking across the sense resistor. When the required current level has been reached, the top switch is turned off and the stored energy in the coil keeps the current circulating via the bottom switch and the diode. Losses in the system cause this current to slowly decay, and when a pre-set lower threshold is reached, the top switch is turned back on and the cycle repeats. The current is therefore maintained at the correct average value by switching or "chopping" the supply to the motor.

This method of current control is very efficient because very little power is dissipated in the switching transistors other than during the transient switching state. Power drawn from the power supply is closely related to the mechanical power delivered by the shaft (unlike the R-L drive, which draws maximum power from the supply at standstill).

A variant of this circuit is the regenerative chopper. In this drive, the supply voltage is applied across the motor winding in alternating directions, causing the current to ramp up and down at approximately equal rates. This technique tends to require fewer components and is consequently lower in cost, however, the associated ripple current in the motor is usually greater and increases motor heating.

Regeneration and Power Dumping

Like other rotating machines with permanent magnets, the step motor will act as a generator when the shaft is driven mechanically. This means that the energy imparted to the load inertia during acceleration is returned to the drive during deceleration. This will increase the motor current and can damage the power switches if the extra current is excessive. A threshold detector in the drive senses this increase in current and momentarily turns off all the bridge transistors (Fig. 2.10). There is now a path for the regenerated current back to the supply capacitor, where it increases the supply voltage. During this phase, the current is no longer flowing through the sense resistors, so the power switches must be turned on again after a short period (typically $30\mu\text{s}$) for conditions to be reassessed. If the current is still too high, the drive returns to the regenerative state.

Fig. 2.10 Current flow during regeneration

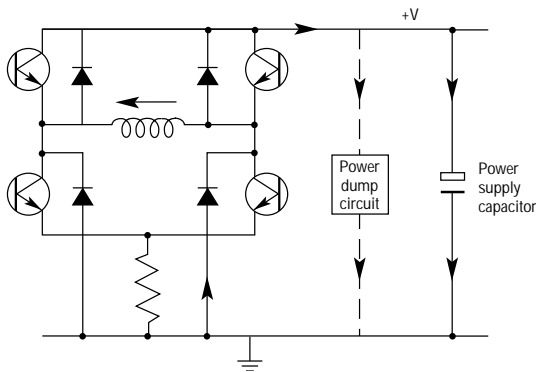

A small increase in supply voltage during regeneration is acceptable, but if the rise is too great the switches may be damaged by over-voltage rather than excessive current. To resolve this problem, we use a power dump circuit that dissipates the regenerated power.

The circuit of a simple power dump is shown in Fig. 2.11. A rectifier and capacitor fed with AC from the supply transformer provide a reference voltage equal to the peak value of the incoming AC. Under normal conditions this will be the same as the drive supply voltage. During excess regeneration, the drive supply voltage will rise above this reference, and this will turn on the dump transistor connecting the 33-ohm resistor across the power supply. When the supply voltage has decreased sufficiently, the transistor is turned back off. Although the instantaneous current flowing through the dump resistor may be relatively high, the average power dissipated is usually small since the dump period is very short. In applications where the regenerated power is high, perhaps caused by frequent and rapid deceleration of a high inertia, a supplementary high-power dump resistor may be necessary.

Fig. 2.11 Power dump circuit

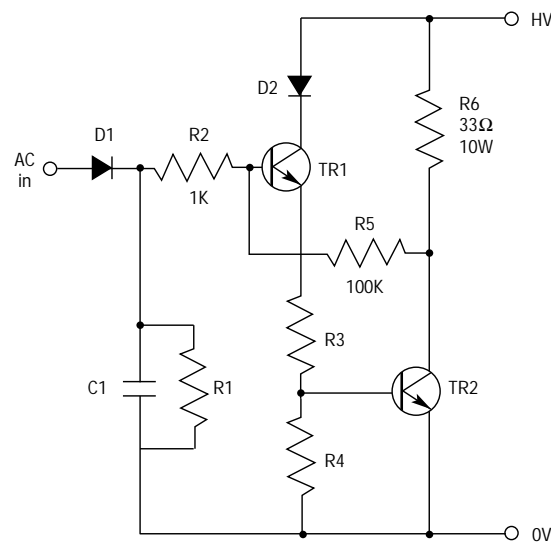

Stepper Drive Technology Overview

Within the various drive technologies, there is a spectrum of performance. The uni-polar resistance-limited (R-L) drive is a relatively simple design, but it lacks shaft power performance and is very inefficient. A uni-polar system only uses half of the motor winding at any instant. A bi-polar design allows torque producing current to flow in all motor windings, using the motor more efficiently, but increasing the complexity of the drive. A bi-polar R-L drive improves shaft performance, but is still very inefficient—generating a lot of wasted heat. An alternative to resistance-limiting is to control current by means of chopper regulation. A chopper regulator is very efficient since it does not waste power by dropping voltage through a resistor. However, good current control in the motor is essential to deliver optimum shaft power. Pulse width modulation (PWM) and threshold modulation are two types of chopper regulation techniques. PWM controls the average of the motor current and is very good for precise current control, while threshold modulation controls current to a peak level. Threshold modulation can be applied to a wider range of motors, but it does suffer greater loss of performance than PWM when the motor has a large resistance or long motor cables are used. Both chopper regulation techniques can use recirculating current control, which improves the power dissipation in the motor and drive and overall system efficiency. As system performance increases, the complexity and cost of the drive increases.

Stepper drive technology has evolved—being driven by machine builders that require more shaft power in smaller packages, higher speed capability, better efficiency, and improved accuracy. One trend of the technology is towards microstepping, a technique that divides each full step of the motor into smaller steps. This is achieved electronically in the drive by proportioning the current between the motor windings. The higher the resolution, the more precision is required in the current control circuits. In its simplest form, a half-step system increases the resolution of a standard 1.8° full-step motor to 400 steps/rev. Ministepping drives have more precise current control and can increase the resolution to 4,000 steps/rev. Microstep drives typically have resolutions of 50,000 steps/rev, and in addition to improved current control, they often have adjustments to balance offsets between each phase of the motor and to optimize the current profile for the particular motor being used.

Full-Step and Half-Step Systems

Full-step and half-step systems do not have the resolution capability of the ministepping or microstepping systems. However, the drive technology is not as complex and the drives are relatively inexpensive. Full-step and half-step systems will not have the same low-speed smoothness as higher resolution systems.

An inherent property of a stepper motor is its low-speed resonance, which may de-synchronize a motor and cause position loss. Full-step and half-step drives are more prone to resonance effects and this may limit their application in low-speed systems. Full-step and half-step systems can be operated at speeds above the motor's resonant speed without loss of synchronization. For this reason, full-step and half-step systems are normally applied in high-speed, point-to-point positioning applications. In these types of applications, the machine designer is primarily concerned with selecting a motor/drive system capable of producing the necessary power output.

Since power is the product of torque and speed, a high-torque system with low-speed capability may not produce as much power as a low-torque, high-speed system. Sizing the system for torque only may not provide the most cost-effective solution, selecting a system based on power output will make the most efficient use of the motor and drive.

Step motor systems typically require the motor to accelerate to reach high speed. If a motor was requested to run instantaneously at 3000 rpm, the motor would stall immediately. At slow speeds, it is possible to start the motor without position loss by applying unramped step pulses. The maximum speed at which synchronization will occur without ramping is called the *start/stop velocity*. The start/stop velocity is inversely proportional to the square-root of the total inertia. The start/stop capability provides a benefit for applications that require high-speed point-to-point positioning—since the acceleration to the start/stop velocity is almost instantaneous, the move-time will be reduced. No additional time is required to accelerate the motor from zero to the start/stop velocity. While the move-time can be reduced, it is generally more complicated for the controller or indexer to calculate the motion profile and implement a start/stop velocity. In most applications, using start/stop velocities will eliminate the need to run the motor at its resonant frequency and prevent de-synchronization.

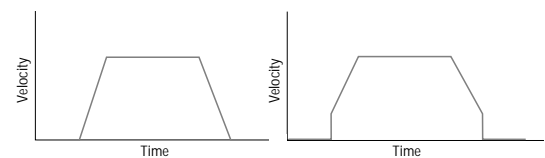

Ministep Systems

Applications that require better low-speed smoothness than a half-step system should consider using a microstepping or ministepping solution. Microstepping systems, with resolutions of 50,000 steps/rev, can offer exceptional smoothness, without requiring a gear-reducer. Ministepping systems typically do not have wave-trimming capability or offset adjustment to achieve the optimum smoothness, but offer a great improvement over full-step and half-step systems. Ministepping systems have resolutions between 1,000 and 4,000 steps/rev.

The motor is an important element in providing good smoothness. Some motor designs are optimized for high-torque output rather than smooth rotation. Others are optimized for smoothness rather than high torque. Ministepping systems are typically offered with a motor as a “packaged” total solution, using a motor that has been selected for its premium smoothness properties.

Ministep systems are sometimes selected to improve positional accuracy. However, with an open-loop system, friction may prevent the theoretical unloaded accuracy from being achieved in practice.