



BI-POLAR CHOPPER STEPPER MOTOR CONTROL MODULE

Features

- Develops maximum possible motor torque by using dual coil-current sensing & control loop circuits
- Allows use of drive voltage beyond rated motor specification for enhanced torque & speed
- Chopper drive circuitry is current adjustable up to 2 Amps/coil using dual internal 5W sense resistors
- Motor supply voltage 0V to 46V
- Integral heatsink system and thermal potting compound eliminate need for an auxiliary heatsink or fan
- Eight internal 3A Schottky clamp diodes and large filter capacitors for enhanced noise suppression
- Two modes of current chopping provide efficient operation of both large and small stepper motors
- Internally generated voltage source for easily setting maximum coil current
- Primary drive circuit thermal overload protection
- Standard 24 pin DIP pin spacing for easy PCB placement & prototyping
- Threaded mounting coupler allows secure mount to PCB in rugged applications
- Chopping frequency generated internally; externally generated frequency may also be used

Overview

The EDE12400 stepper motor control module offers designers a compact, reliable stepper motor control system. Engineered with internal and external heatsinks and a highly thermally conductive potting compound, the need for cooling fans (known for short lifetimes) or a large heatsink plate is eliminated. An integrated chopper drive circuit safely provides the maximum motor torque for a given drive voltage, even one many times over the manufacture-specified voltage, offering tremendous torque and speed improvements over traditional stepper motor control circuits. Maximum coil current is easily set using a potentiometer or voltage divider, and can be dynamically adjusted. The highly efficient design of the EDE12400 drive circuitry combined with its unique PowerCube™ package makes it the ideal motor control solution for nearly any application.

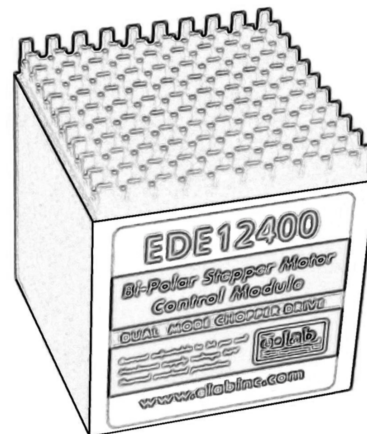

Specification Summary

- Max. motor voltage 46V
- Max. current 2 Amps per coil
- Full/half stepping and direction control
- Complete stepper motor control unit
- Based on the proven L297/L298™ chipset

Typical Applications

- CNC / Milling Machines
- Robotics
- Industrial Equipment
- Remote-Positioning Equipment
- Scientific Apparatus
- Valve Controls

Module Pinout

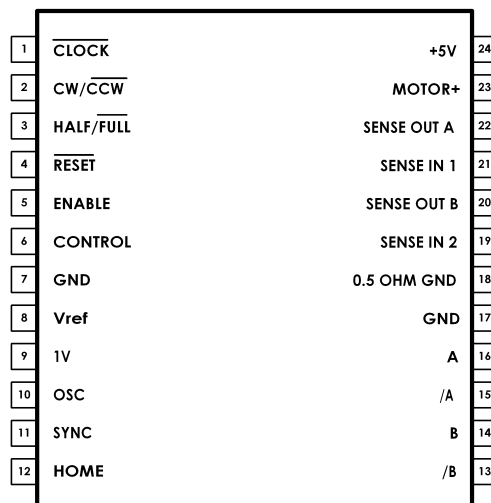

Pin#	Pin Name	Description
1	$\overline{\text{CLOCK}}$	Step clock. An active low pulse on this input advances the motor one increment. The step occurs on the rising edge of this signal.
2	$\overline{\text{CW/CCW}}$	Clockwise/Counterclockwise direction control input. Physical direction of motor rotation also depends on connection of windings. Direction can be changed at any time.
3	$\overline{\text{HALF/FULL}}$	Half/full step select input. When high selects half step operation, when low selects full step operation. One-phase-on full step mode is obtained by selecting FULL when the translator is at an even-numbered state. Two-phase-on full step mode is set by selecting FULL when the translator is at an odd numbered position. (The home position is designated state 1).
4	$\overline{\text{RESET}}$	Reset input. An active low pulse on this input restores the translator to the home position (state 1, ABCD = 0101).
5	ENABLE	Chip enable input. When low (inactive) INH1, INH2, A, B, C, and D are brought low.
6	CONTROL	Control input that defines action of chopper. When low chopper acts on INH1 and INH2; when high chopper acts on phase lines ABCD.
7	GND	Ground connection.
8	Vref	Reference voltage input for chopper circuit. A voltage applied to this pin determines the peak load current. When using internal 0.5 Ohm current sense resistors, do not exceed 1V (sets 2 Amps).
9	1V	1V output voltage. May be used to feed a voltage divider circuit to set Vref input voltage. Using this output to drive a potentiometer or other voltage divider that sets Vref prevents (desirably) the possibility of sending a voltage higher than 1V into Vref.
10	OSC	RC oscillator to set chopper rate. In ordinary operation this pin may be left unconnected to use the internal RC oscillator. If multiple modules are to be utilized and their chopper outputs are to be synchronized, this pin should be grounded on all but one module. The module with the ungrounded OSC pin provides the chopper clock to the other modules via the SYNC pin.
11	SYNC	Output of the chopper oscillator. In ordinary operation this pin may be left unconnected. If an external chopper clock source is to be used it is injected at this pin. If multiple modules must have their chopper frequencies synchronized their SYNC pins should be connected.
12	HOME	Open collector output that indicates when the controller is in its initial state (ABCD = 0101). The output transistor is open when the signal is active.
13	/B	Motor phase 4 output drive signal. Connected to same coil as B.
14	B	Motor phase 3 output drive signal. Connected to same coil as /B.
15	/A	Motor phase 2 output drive signal. Connected to same coil as A.
16	A	Motor phase 1 output drive signal. Connected to same coil as /A.
17	GND	Ground connection.
18	0.5 Ohm Ground	Ordinarily connected to Ground if internal current sense resistors are to be used. If external current sense resistors are used, leave this pin floating.
19	Sense In 2	Input for load current sense resistor for coil across B and /B. For standard operation connect to Sense Out B.
20	Sense Out B	Output drive to load current sense resistor for coil across B and /B.
21	Sense In 1	Input for load current sense resistor for coil across A and /A. For standard operation connect to Sense Out A.
22	Sense Out A	Output drive to load current sense resistor for coil across A and /A.
23	MOTOR+	Motor power supply input. Maximum 46VDC.
24	+5V	Regulated +5V input.

Table One: Pin Functionality

Introduction

The EDE12400 Stepper Motor Control Module is built upon the L297/L298 chopper drive chipset manufactured by ST-Microelectronics. Support circuitry is incorporated to provide a complete bipolar chopper stepper motor interface. This datasheet may be used in conjunction with the L297 Datasheet, L298 Datasheet, and L297 Application Note for greater detail. These three documents are available from the E-Lab website (www.elabinc.com), the St-Microelectronics website (www.st.com), or the E-Lab Datasheet CD. As illustrated in Figure One, minimal external components are required to implement a full-featured chopper drive stepper motor control system.

Operational Overview

The EDE12400 contains all necessary circuitry for controlling a bipolar stepper motor at coil currents up to 2 Amps. Full & half stepping, directional control, motor enable/disable, and automatic current regulation provide a powerful, easy-to-use motion control system. The built-in chopper frequency generation and current sensing circuitry drives the motor at a presettable coil current which is determined by the voltage fed to the Vref input (pin 8).

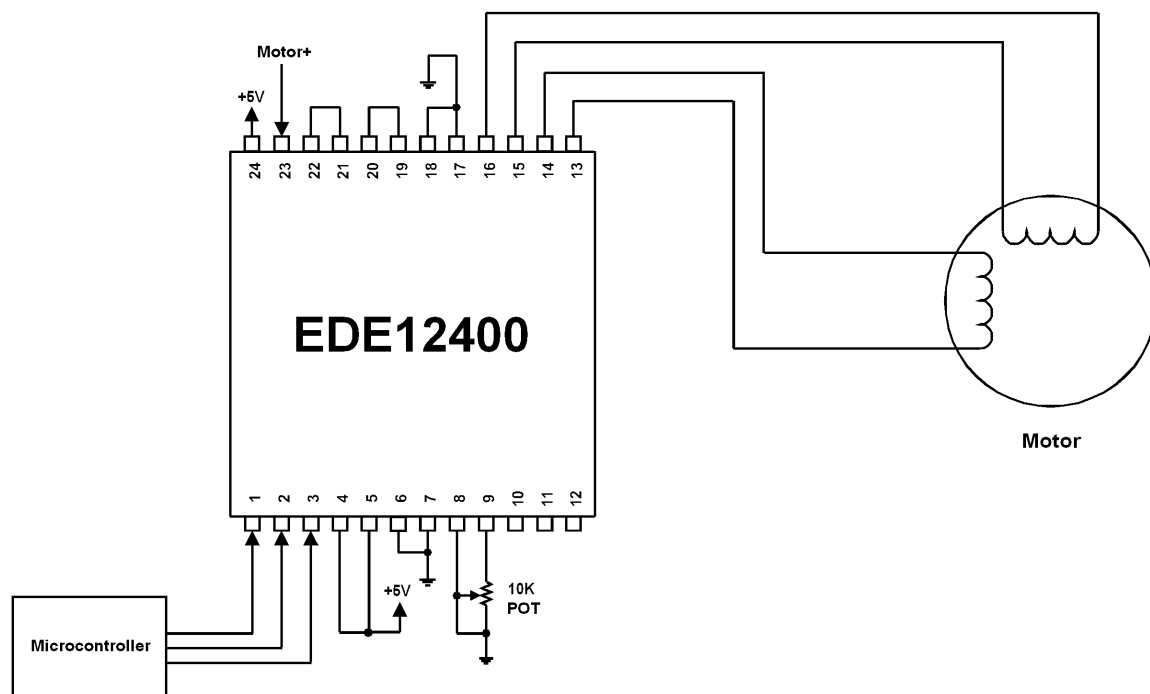

Figure One: Standard Module Hookup

When connected as shown in Figure One, the EDE12400 module will operate the motor based upon the inputs of the CLOCK, CW/CCW, HALF/FULL, and RESET pins. With the RESET pin high (its inactive state), a low-going (+5V to 0V) pulse on the CLOCK input will cause the motor to rotate one step at the low-to-high transition of the pulse. The CW/CCW pin determines the direction of shaft rotation. The HALF/FULL pin determines whether the module uses a standard full-step drive sequence (providing a 1.8°/per step rotation on a 1.8°/per step motor) or a half-step drive sequence (providing a 0.9°/per step rotation on a 1.8°/per step motor).

The drive outputs (A, /A, B, /B) that connect to the motor coils (see Figure One) cycle through one set of the following states depending upon whether full or half-stepping is selected. State 1, termed the 'Home' state, is the default power-on and reset state. The open-collector output HOME (pin 12) is active when the module is in state 1. Further discussion of output states may be found beginning page 5 of the L297 datasheet.

STATE	A	/A	B	/B
1	0	1	0	1
3	1	0	0	1
5	1	0	1	0
7	0	1	1	0

Table Two: Full Step Output States

STATE	A	/A	B	/B
1	0	1	0	1
2	0	0	0	1
3	1	0	0	1
4	1	0	0	0
5	1	0	1	0
6	0	0	1	0
7	0	1	1	0
8	0	1	0	0

Table Three: Half-Step Output States

Chopper Drive Fundamentals

Stepper motor torque is inversely proportional to motor rotation speed due to the inductance of the motor's coils. As rotational speed increases, it is more difficult to push the required amount of current into (and pull out of) the coils in the shorter period of time they are driven per step. As coil current decreases, so does motor torque. To overcome this, it is desirable to increase the drive voltage beyond the motor's rated voltage to increase current flow. Doing so leads to a problem, however, in that at lower speeds an overcurrent situation develops and the motor quickly overheats. The use of a chopper drive system, which places a higher voltage across the coils until the desired current setpoint is reached, allows coil current to remain at a desired level for both high and low speeds without the fear of overheating the motor or overdriving the coils. The EDE12400 applies motor input power to the coils as a square wave with varying duty cycle to dynamically control coil current. The drive frequency is set to 20KHz by an internal RC oscillator.

When connected as shown in Figure One, coil current is passed through internal 0.5 Ohm power resistors and then flows to ground. By measuring the voltage across these resistors the coil current may be determined. Following Ohm's law ($i = v/r$), the current through a resistor is equal to the voltage across the resistor divided by resistance, in this case 0.5 Ohms. As an example, if the voltage across one of the 0.5 Ohm sense resistors is 0.5 Volts, one Amp of current is flowing through the resistor, and therefore through the motor coil as well. When the EDE12400 detects that there is less current flowing through the coil than there should be it connects the Motor+ (pin 23) voltage input to the coil. As current begins to flow, the voltage across the sense resistor increases. When the increasing sense resistor voltage becomes equal to the Vref input voltage, the Motor+ voltage is

removed from the coil until the next chopper cycle (at 20KHz, the PWM period is 50us). Because the maximum module current is 2 Amps per coil, care should be taken to ensure that the maximum voltage applied to the Vref input is 1 Volt; otherwise current will exceed 2 Amps per coil and damage to the module may occur. To aid in usage, a 1V output (pin 9) is available to drive a voltage divider or potentiometer. Using this 1V signal (as opposed to +5V or more) ensures that the Vref current control input stays within the 0-1 Volt range. A simple voltage divider arrangement uses two resistors in series with one end connected to the 1V output from the module and the other end to ground. The connection point between the two resistors is then connected to the Vref input as the input voltage for the current limit. As an example, to limit current flow to .5 Amps (500mA) per coil one would need to place a voltage of 0.25V onto the Vref pin. This may be accomplished using a 5K and a 20K resistor in series, with the 5K resistor connected to ground on one end. A potentiometer may also be used as a voltage divider; one end connected to the 1V output of the module, the other to Ground, and the wiper to the module's Vref input. This arrangement is illustrated in Figure One.

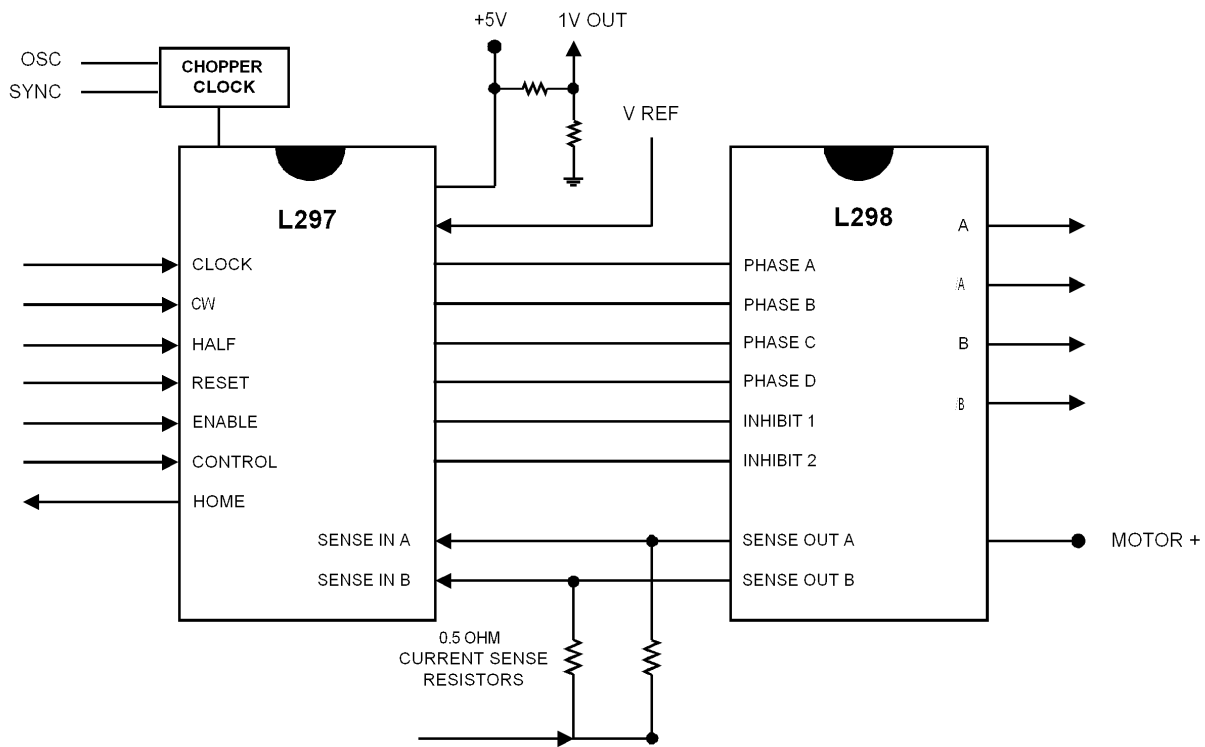

Figure Two: Internal 297-298 Connection Block Diagram

As illustrated by Figure Two, connection to the internal current sense resistors is available externally to the module at pin 18, the '0.5 Ohm GND' pin. Ordinarily, when using the internal sense resistors, Sense Out A (pin 22) is connected to Sense In 1 (pin 21), Sense Out B (pin 20) is connected to Sense In 2 (pin 19), and 0.5 Ohm GND (pin 18) is connected to GND. If the use of external sense resistors is desired instead (for instance, to reduce power consumption), one leg of each of the two external sense resistors should be connected to Sense Out A and Sense Out B with the other two legs grounded. The 0.5 Ohm GND (pin 18) should be left floating, and Sense In 1 & Sense In 2 should be connected to sense Out A & Sense Out B, respectively. Care should be taken to ensure that if external resistors are used they are capable of carrying the maximum coil current.

Synchronizing Multiple Modules

The SYNC pin (pin 11) makes the output of the chopper drive clock available externally. If multiple EDE12400 modules are to be used in a system (see Figure Three), the SYNC pins should be tied together and all but one OSC pin (pin 10) connected to Ground. The module with the ungrounded OSC pin generates the clock frequency.

NOTE: Although they may be operated independently, synchronizing EDE12400 Modules as illustrated in Figure Three reduces the possibility of noise interference between the chopper drivers of the modules.

If a module (or modules) are to be given an external chopper drive signal (for instance, to use a frequency other than 20KHz), all the OSC pins should be connected to ground and the desired signal input into the SYNC pin(s) as a 0-5V square wave. This drive frequency should not exceed 40MHz.

In applications where the chopper drivers are to be disabled, The Sense Out A, Sense Out B, Sense In 1, and Sense In 2 pins must all be connected to ground. The Vref input should be connected to ground as well, and the 0.5 Ohm GND pin may be left unconnected. It is important to remember that with the chopper driver deactivated the motor supply voltage must not exceed the motor's rated voltage.

For additional details on coil current sensing or driver synchronization, please refer to the L297 datasheet and the L297 Application Note.

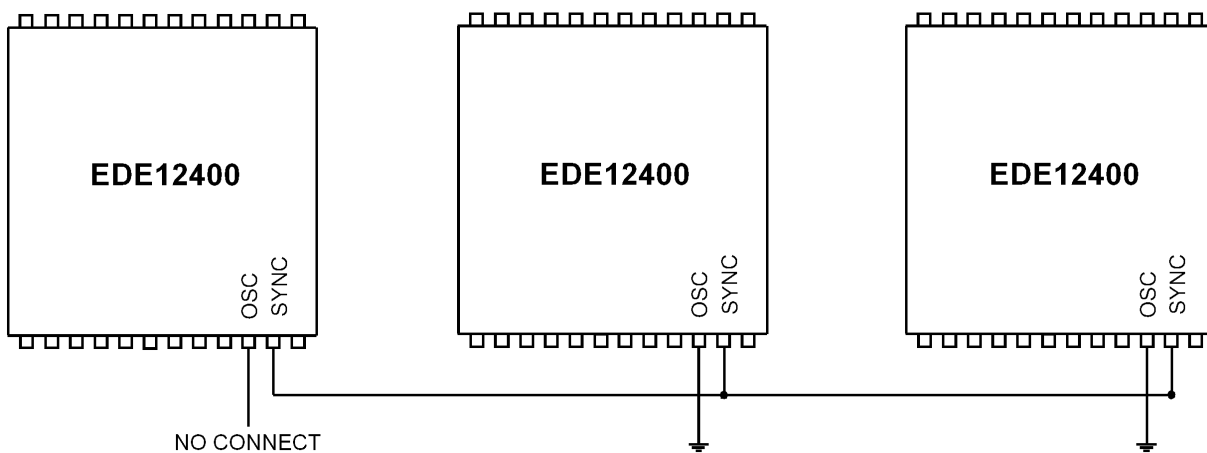
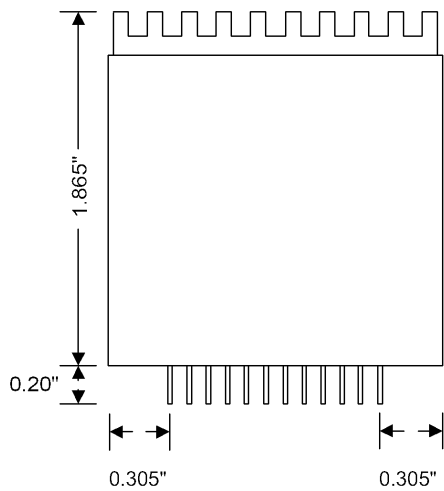

Figure Three: Synchronizing the Chopper Drivers of Multiple EDE12400's

Phase vs. Enable Chopping

The CONTROL input (pin 6) selects one of two types of chopping that is performed by the module. When CONTROL is low the chopper acts on INH1 and INH2; when high it acts on phase lines ABCD. When the chopper acts on inhibit lines INH1 and INH2, coil current decay is accelerated due to current recirculation through the active output transistors & clamp diodes. Ordinarily the CONTROL input should be connected to ground to provide maximum motor speeds, but in some instances (especially with small motor coils that are not able to store much energy) it is advantageous to chop phase lines ABCD instead (CONTROL input high) to enhance available torque. For a complete discussion of the two types of chopping please refer to pages 8-12 of the L297 Application Note.

Mechanical Dimensions



Front View

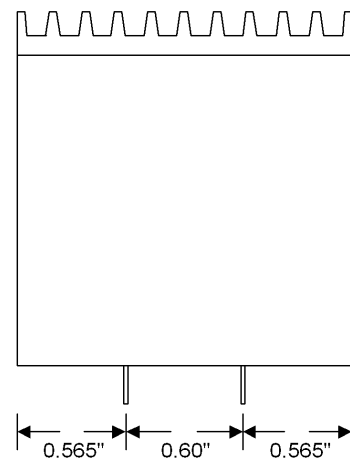

Side View

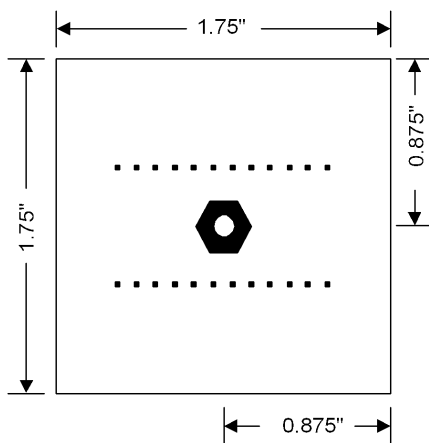

Bottom View

- Notes:**
1. Connection pins are in a standard 24 pin wide DIP arrangement, 600 (0.6") mil wide.
 2. Pin spacing is 100 mil (0.1")
 3. Pins require 45 mil (0.45") diameter PCB hole
 4. Allow minimum 1/8" clearance on all four sides of module for ventilation.
 5. Center mounting coupler is female 4-40 thread, 1/4" deep.



IMPORTANT NOTICE

E-LAB Digital Engineering, Inc. (E-LAB), reserves the right to change products or specifications without notice. Customers are advised to obtain the latest versions of product specifications, which should be considered when evaluating a product's appropriateness for a particular use.

THIS PRODUCT IS WARRANTED TO COMPLY WITH E-LAB'S SPECIFICATION SHEET AT THE TIME OF DELIVERY. BY USING THIS PRODUCT, CUSTOMER AGREES THAT IN NO EVENT SHALL E-LAB BE LIABLE FOR ANY DIRECT, INDIRECT, SPECIAL, INCIDENTAL OR CONSEQUENTIAL DAMAGES AS A RESULT OF THE PERFORMANCE, OR FAILURE TO PERFORM, OF THIS PRODUCT.

E-LAB MAKES NO OTHER WARRANTIES, EXPRESSED OR IMPLIED, INCLUDING ANY IMPLIED WARRANTIES OF MERCHANTABILITY OR FITNESS FOR A PARTICULAR PURPOSE.

COPYRIGHT NOTICE

This product may not be duplicated. E-LAB Digital Engineering, Inc. holds all copyrights on schematic, with all rights reserved. Unauthorized duplication of this device will be subject to penalty under state and/ or federal law.

EDE12400 and the E-LAB logo are trademarks of E-LAB Digital Engineering, Inc. All other trademarks and registered trademarks are property of their respective owners.

All modules are tested and certified 100% operational prior to shipment. E-Lab's warranty responsibility is limited to manufacturing defects and does not cover damage or malfunctions resulting from misuse, abuse, modification, or attempted repairs. Manufacturing defects must be reported to E-Lab within 30 days of delivery to be covered under warranty.

E-LAB'S PRODUCTS ARE NOT AUTHORIZED FOR USE AS CRITICAL COMPONENTS IN LIFE SUPPORT DEVICES. Life support devices or systems are those which are intended to support or sustain life and whose failure to perform can be reasonably expected to result in a significant injury or death to the user. Critical components are those whose failure to perform can be reasonably expected to cause failure of a life support device or system or affect its safety or effectiveness.

E-LAB Digital Engineering, Inc.
Carefree Industrial Park
1600 N. 291 Hwy. #330
Independence, MO 64056

Telephone: (816) 257-9954
FAX: (816) 257-9945

Internet:
www.elabinc.com



E-Mail:
support@elabinc.com