

4-Q PWM Servo – 10 A

For Brushless-Commutated DC Motors up to 700 W

SCA-B4-70-10



- Servo amplifier in a rugged aluminium housing
- Different methods of mounting for fast installation
- Inputs and outputs via screw terminals
- Operation mode setting with jumpers
- User adjustable current limit
- Wide range supply voltage between +11 and +70 VDC for different kinds of DC-power supplies
- Protected against overtemperature and over-current
- MOSFet-technology, efficiency 95%
- Continuous current up to 10 A

Basic drive description: The SCA-B4-70-10 servo amplifiers are designed to drive DC brushless type motors. They require a single DC power supply for operation. The drives are to be used with a single motor. They have the functionality to operate as an independent speed control or high performance servo. The drives are protected against short circuits, under voltage, over temperature, and over current. It has multiple modes of operation and serves as a reliable choice for your motion control needs.

Table of Contents

1. Safety & Installation	3
2. Specifications:	4
3. Drive Overview	7
4. Wiring.....	10
5. Explanation of Terminals, Potentiometers & Jumpers	19
6. Glossary	23
7. Description of Inputs and Outputs.....	29
8. Basic Troubleshooting.....	33
9. Accessories & Options	34
10. Warranties & Disclaimers	35
11. Dimensions	36
12. Mounting Din rail adapter	37

Used Symbols



Indicates a warning or caution concerning operations that may lead to death or injury to persons, or damage to property if not performed correctly. In order to use the drive safely, always pay attention to these warnings.



Indicates a clarification of an operation, or contains additional explanations, or operational requirements for a procedure. Reading these notes is much recommended.

1. Safety & Installation



The SCA-B4-70-10 requires installation by qualified personal which must pay attention to significant safety and other regulatory standards. They should be thoroughly familiar with the entire system before beginning installation.



Before final operation of machine be sure to test hookup with motor disconnected from the load. Improper wiring could cause a “motor run away” condition, and cause serious injury or damage to the machine and personal.



Before starting installation of the SCA-B4-70-10, be sure that main power is disconnected. After powering the drive it should not be touched by hand or risk shock.



Take care that in case of regeneration or in brake operation the energy recovery must be buffered by the power supply and / or a braking module. Ensure with electronically stabilized power supplies that protection circuit isn't react.

Don't switch off the power supply while the motor is turning, in this case the drive could be destroyed by regeneration.

We recommend connecting a capacitor of 1000 μ F per each ampere output current close to power input, in parallel.



Do not repair or open drives enclosure. Result would result in personal injury and would void all warranties.



The SCA-B4-70-10 complies with the European directive EN61800-3 (1996). The followings points must followed:

- A metal mounting plate with correct grounding is mandatory.
- For installation purposes, tooth lock washers have to be used.
- For most wiring schemes, only shielded cables are admissible, to suppress interference with other devices. Damaged items have to be replaced.
- Provide for a large contact area between shields and mounting plate.
- The motor has to be grounded.
- The drive is an Electrostatic Sensitive Device (ESD). Electrostatic discharge needs to be avoided



NOTE:

Certain applications may involve special requirements. Consult Factory!

2. Specifications:

2.1 Electrical Data

Power Supply Voltage	+11 to +70 VDC (Residual ripple <5 %) (The lower limit is monitored by integrated undervoltage trip) WARNING: Do not exceed 70V. Overvoltage will damage the drive.
Nominal Current	10 A
Peak Current	20 A
Maximum Power (only achievable with additional heatsink & proper mounting, see accessories.)	700 W
Switching Frequency	49 kHz
Efficiency	95 %
Induction Specification & caution for low inductance motors	Optional choke modules are often an economical solution for low inductance or other motors, if an overheating situation occurs in regular intervals. Contact factory service for details.
Power terminals	The diameter must be suited for the current load. The recommendation for the drive is 1,5 mm ² (AWG16). Maximum wire diameter with respect to the terminal is 2,5 mm ² (AWG14) or 1,5 mm ² (AWG16) for stranded wires. Strip the wire insulation of the cables on a length of maximal 8 mm. For stranded wire, use end sleeves with the corresponding length.
Signal terminals	The recommendation is 0,5 mm ² (AWG21), the min. is 0,14 mm ² (AWG26) and the max. is 1,5 mm ² (AWG16). Strip the wire insulation of the cables on a length of maximal 7 mm. For stranded wire, use end sleeves with the corresponding length.

2.2 Mechanical Data

Mechanical Dimensions L x W x H	180 x 100 x 40 mm
Weight	580 g
Mounting	M4 screws or Din Rail Mounting

2.3 Ambient Conditions

Operation Temperature	-10 to +45 °C
Storage Temperature	-40 to +85 °C
Humidity (Non Condensing)	20 % to 80 % RH
Overtemperature Protection	+80 °C

2.4 Digital and Analog Inputs

<i>Enable</i>	8...+30 VDC; Resistance = 4,7 kOhm
<i>Hall A, B, C</i>	TTL, +5 VDC; Resistance = 1 kOhm
<i>Encoder A, B</i>	TTL, +5 VDC; Resistance = 1 kOhm; max. 100 kHz
<i>-Set value -- +Set value</i>	Analog -10 – +10 VDC ; Resistance = 20 kOhm

2.5 Outputs

Auxiliary Voltage Outputs +5V	+5 V / 100 mA
Auxiliary Voltage Output +15V	+15 V / 20 mA
Auxiliary Voltage Output -15V	-15 V / 20 mA
<i>Ready/Error</i>	Open Collector / +30 VDC; max. 20 mA
<i>Monitor I</i>	Analog 0 – +10 VDC with = 0,5 V / A Resistance = 10 kOhm
<i>Monitor n</i>	Analog 0 – +10 VDC ; Resistance = 10 kOhm

2.6 Control LEDs

<i>OK</i>	LED green The LED is lit when the drive is ready to work.	
<i>Fault</i>	LED red The lamp is lit if the overtemperature, the undervoltage, the overvoltage or the overcurrent protection circuit have been initiated.	

3. Drive Overview

3.1 Block Diagram

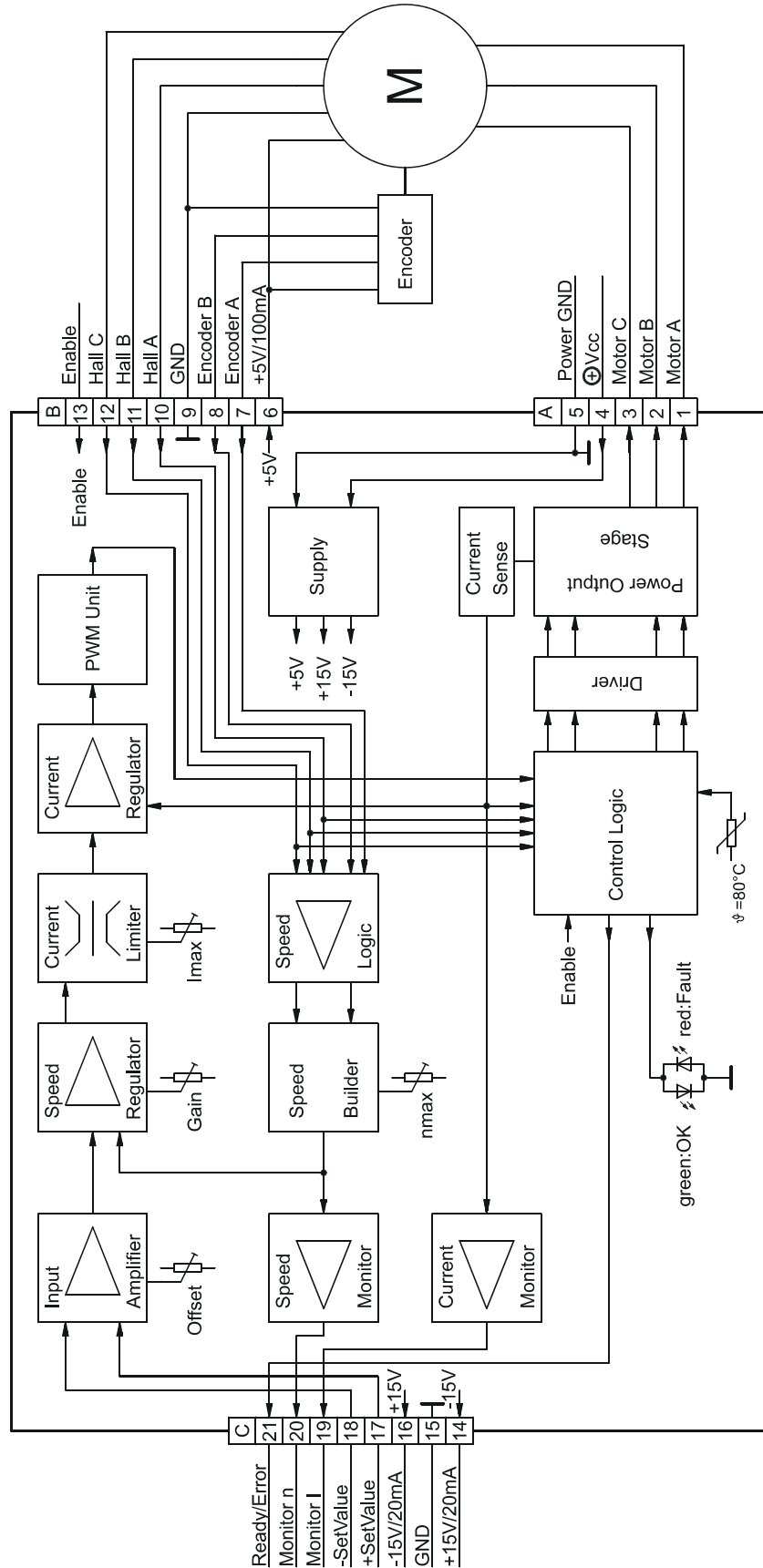

3.2 Input & Output Schematics

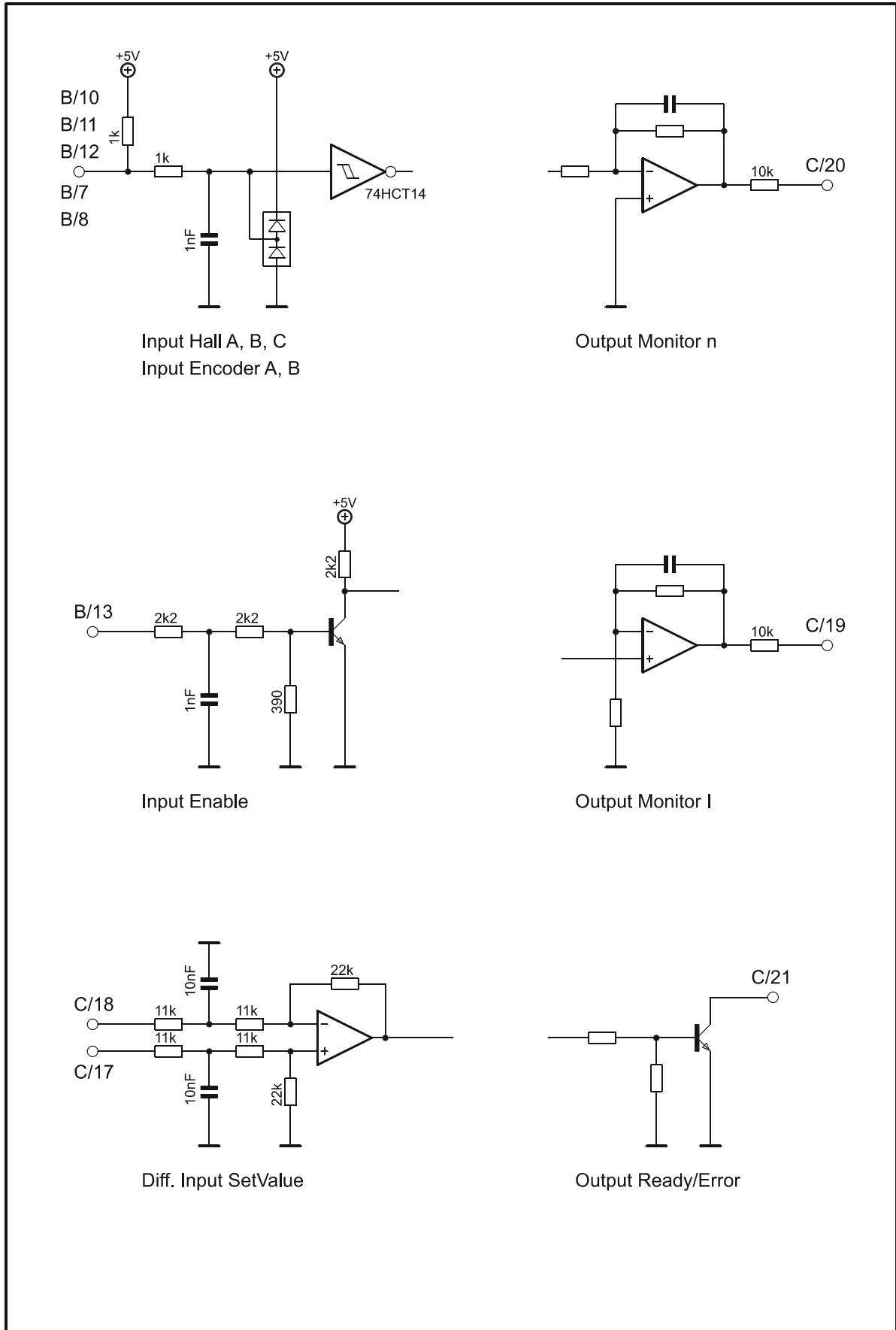

3.3 Control Elements

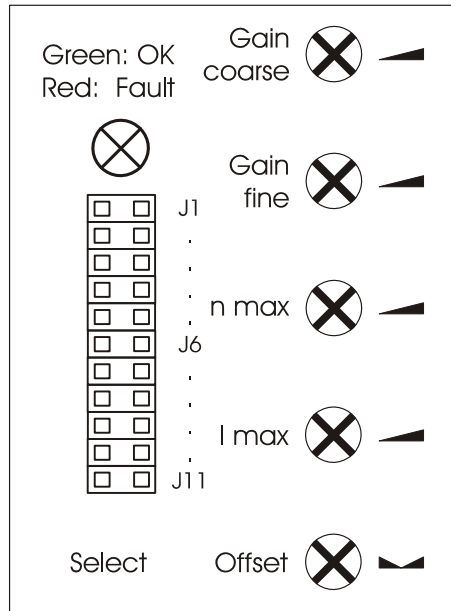

3.4 Operation Modes

Hall Mode

At hall mode the feedback information is coming from hall switches which are mounted in the motor or a hall encoder which is mounted at the motor. The speed regulation is good at each load condition and qualified for each application to control the speed of a system also for high speed application.

Encoder Mode

At encoder mode feedback information is coming from the encoder signals. The encoder is mounted at the motor. The speed regulation has got a high performance at each load condition and qualified for each application to control exactly the speed of a system especially for low speed application. The maximum achievable speed in this mode is limited through the encoder input frequency.

Torque Mode

At torque mode the drive does only control the current of the motor. This control loop is very fast but the speed is moving with the load due to the constant current. This mode is used in application with force control or as a fast power amplifier for positioning systems.

4. Wiring

According to the safety directives, a correct cable selection is mandatory. Regular inspection is advisable. Damaged, burned or kinked items have immediately to be exchanged.

Power ($\oplus V_{cc}$ - *Power GND*)

- Normally no shielding required.
- When connecting several amplifiers to the same supply pack, use star point wiring.

Motor Wiring (> 30 cm)

- Only shielded cables are recommended.
- Connect the shield to the ground lug of the servo amplifier.
- A separate cable has to be used.
- Choke modules are useful to reduce PWM-pulses.

Connection to hall and encoder (> 30 cm)

- Only shielded cables are recommended.
- Connect the shield to the controller.
- A separate cable has to be used.

Analog Signals (*I max*, *+Set value*, *-Set value*, *Monitor I*, *Monitor n*)

- In most cases no shielding required. This may be different for low level signals or in an environment with strong magnetic interference.
- Connect the shield on either end of the cable. For 50/60 Hz interference, remove the shield on one side.

Digital Signals (*Enable*, *Ready/Error*)

- No shielding required.

To verify a trouble-free operation and the conformity to CE regulation, it makes only sense to test the system as a whole, with all components installed (motor, amplifier, supply pack, EMC filters cables etc.).



Note: To improve the noise immunity, always connect unused logical inputs to a fix potential.

4.1 Wiring Example I – Hall Mode

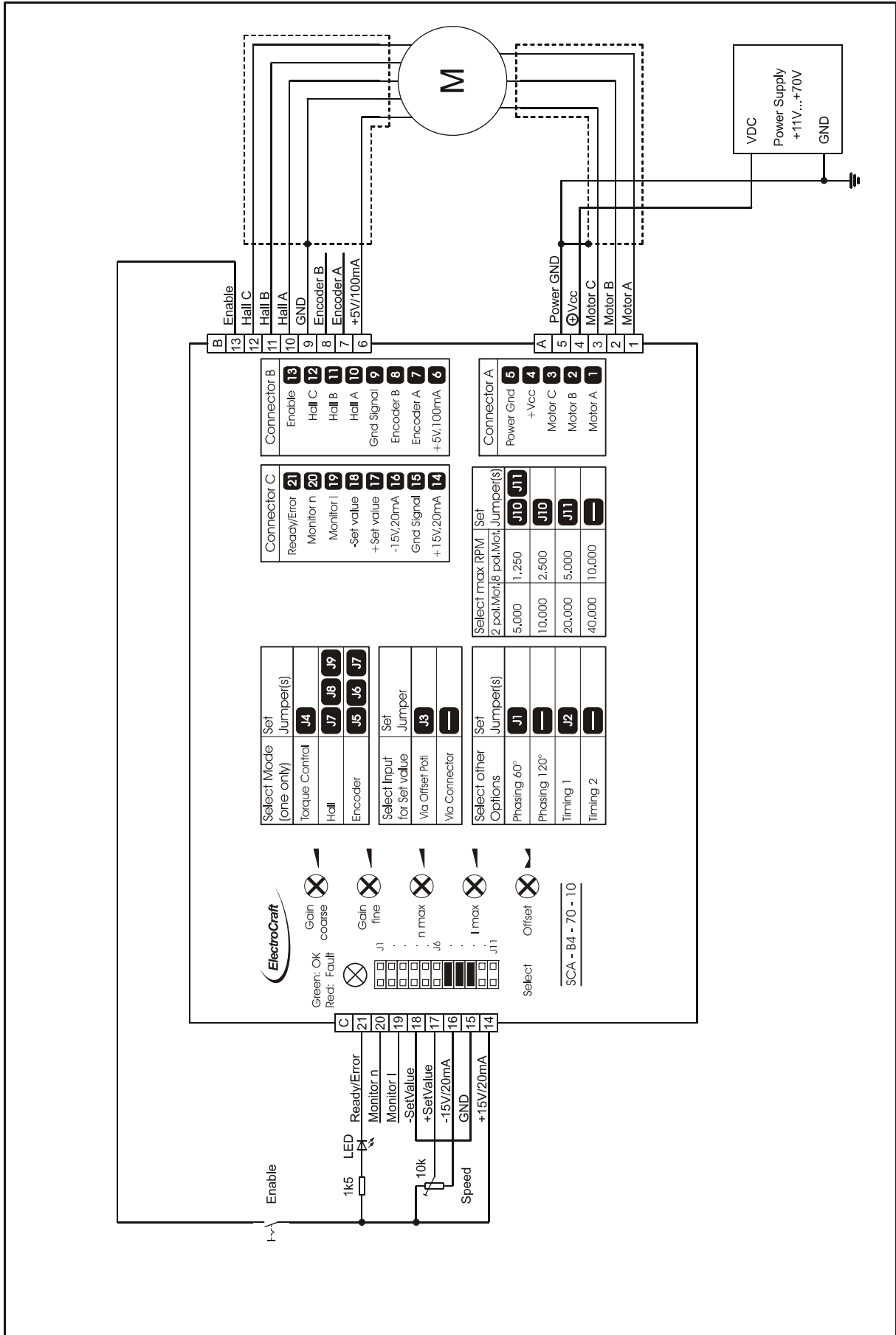

4.1.1 Setting of the Jumpers

Phasing		Timing		Select max. RPM				Set Value via	
60°	120°	1	2	1/1	1/2	1/4	1/8	Offset-pot	Connector



Note: Advanced information's about the jumpers refer chapter 5.3.

4.1.2 Adjustment procedure for *Hall* mode

1. Potentiometer pre setting refer chapter 5.2.
2. After setting of the jumpers set the *Enable* input to HI. Choose the maximum set value (e.g. 10 V). Turn the potentiometer *n max*, until the desired maximum speed is reached.
3. Adjust the current limiter to a value requested by you with the *I max* potentiometer. It is of major importance that this value is lower than the maximum admissible constant current (see motor data sheet). To measure the motor current use the *Monitor I* output, or a current probe in one of the motor cables with a oscilloscope or a multimeter.
4. Set the *Gain fine* potentiometer to the middle, than slowly raise the value of the *Gain coarse* potentiometer. If the motor begins to work unsteadily, to vibrate or to cause excessive noise, carefully lower the gain factor again, until the instability symptoms have disappeared for all load selections. Fine adjusting is possible with *Gain fine* potentiometer.
5. Set the set value to zero and adjust the *Offset* potentiometer until motor is standing still.

4.2 Wiring Example II – Encoder Mode

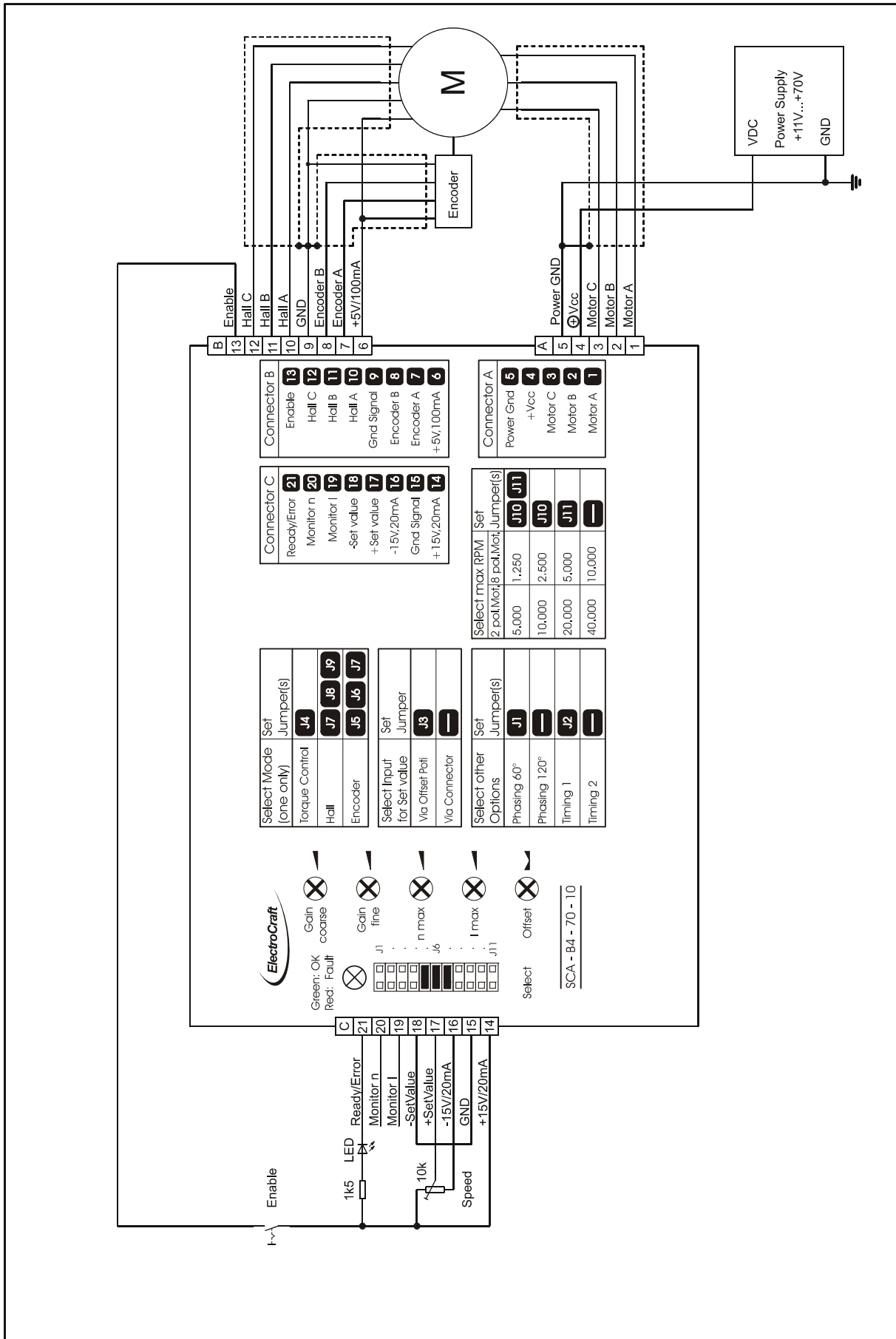

4.2.1 Setting of the Jumpers

Phasing		Timing		Select max. RPM				Set Value via	
60°	120°	1	2	1/1	1/2	1/4	1/8	Offset-pot	Connector



Note: Advanced information's about the jumpers refer chapter 5.3.

4.2.2 Adjustment procedure for *Encoder* mode

1. Potentiometer pre setting refer chapter 5.2.
2. After setting of the jumpers set the *Enable* input to HI. Choose the maximum set value (e.g. 10 V). Turn the potentiometer *n max*, until the desired maximum speed is reached.
3. Adjust the current limiter to a value requested by you with the *I max* potentiometer. It is of major importance that this value is lower than the maximum admissible constant current (see motor data sheet). To measure the motor current use the *Monitor I* output, or a current probe in one of the motor cables with a oscilloscope or a multimeter.
4. Set the *Gain fine* potentiometer to the middle, than slowly raise the value of the *Gain coarse* potentiometer. If the motor begins to work unsteadily, to vibrate or to cause excessive noise, carefully lower the gain factor again, until the instability symptoms have disappeared for all load selections. Fine adjusting is possible with *Gain fine* potentiometer.
5. Set the set value to zero and adjust the *Offset* potentiometer until motor is standing still.

4.3 Wiring Example III – Torque Mode

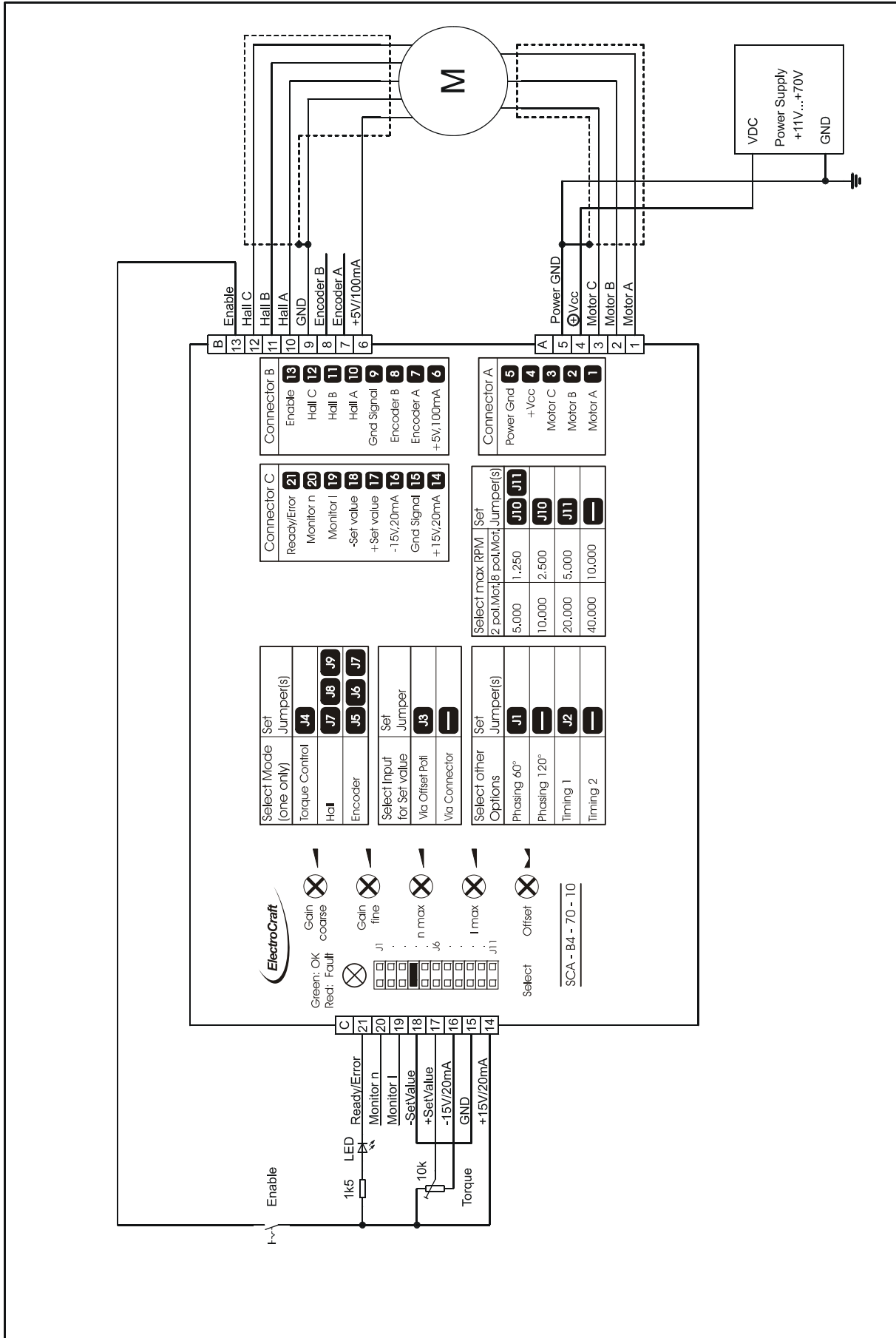

4.3.1 Setting of the Jumpers

Phasing		Timing		Set Value via	
60°	120°	1	2	Offset-pot	Connector



Note: Advanced information's about the jumpers refer chapter 5.3.

4.3.2 Adjustment procedure for *Torque* mode

1. Potentiometer pre setting refer chapter 5.2.
2. After setting of the jumpers set the *Enable* input to HI. Choose the maximum set value (e.g. 10 V). Adjust the current limiter to a value requested by you with the *I max* potentiometer. It is of major importance that this value is lower than the maximum admissible constant current (see motor data sheet). To measure the motor current use the *Monitor I* output, or a current probe in one of the motor cables with a oscilloscope or a multimeter.
3. Set the set value to zero and adjust the *Offset* potentiometer, to the standstill of the motor.

4.4 Wiring Example IV – Minimal Mode

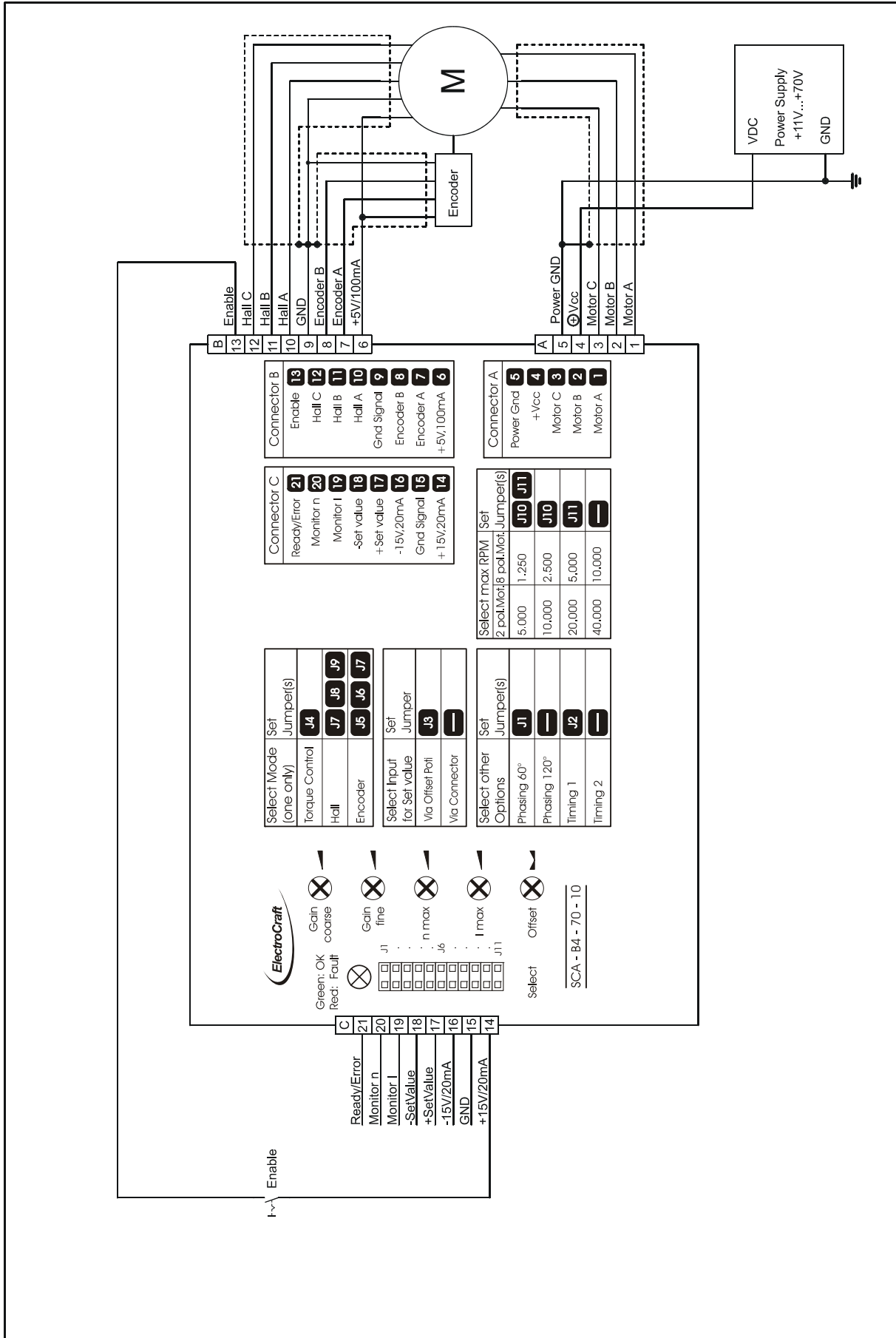

4.5 Wiring Example V

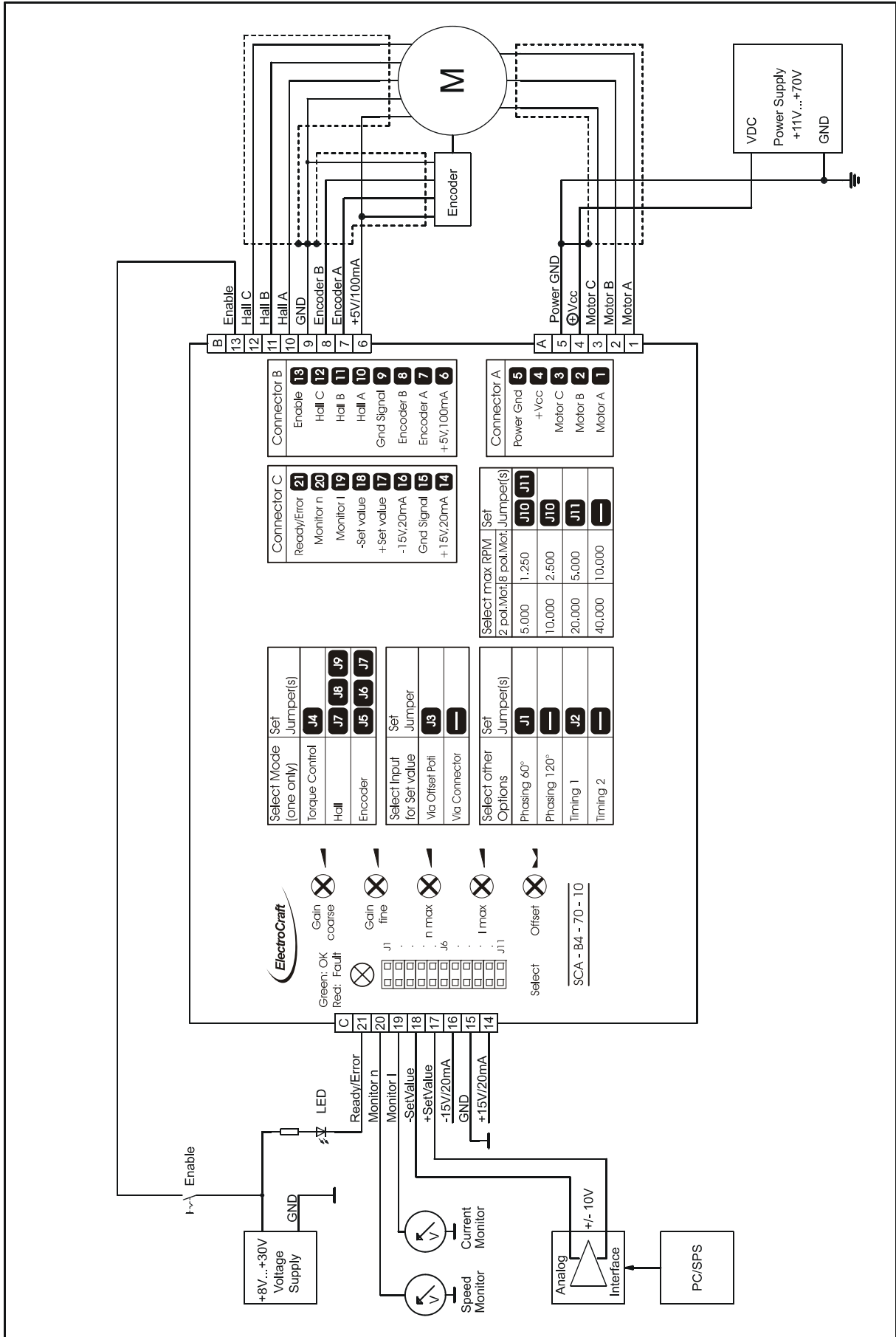

5. Explanation of Terminals, Potentiometers & Jumpers

5.1 Terminals

Terminal	Label	Description
XA	Connector A	Pin 1 & 2 connect to power supply. Pin 3 & 4 & 5 connect to motor.
	Power Gnd 5	
	+Vcc 4	
	Motor C 3	
	Motor B 2	
	Motor A 1	
XB	Connector B	Pin 6 voltage output +5 VDC. Pin 7 & 8 input encoder feedback. Pin 9 signal GND. Pin 10 & 11 & 12 input for hall signals. Pin 13 input <i>Enable</i> .
	Enable 13	
	Hall C 12	
	Hall B 11	
	Hall A 10	
	Gnd Signal 9	
	Encoder B 8	
	Encoder A 7	
	+5V,100mA 6	
XC	Connector C	Pin 14 voltage output +15 VDC. Pin 15 signal GND. Pin 16 voltage output -15 VDC. Pin 17 & 18 input set value. Pin 19 voltage output for current. Pin 20 voltage output speed monitor. Pin 21 output signal <i>Ready/Error</i> .
	Ready/Error 21	
	Monitor n 20	
	Monitor l 19	
	-Set value 18	
	+Set value 17	
	-15V,20mA 16	
	Gnd Signal 15	
	+15V,20mA 14	

5.2 Potentiometers

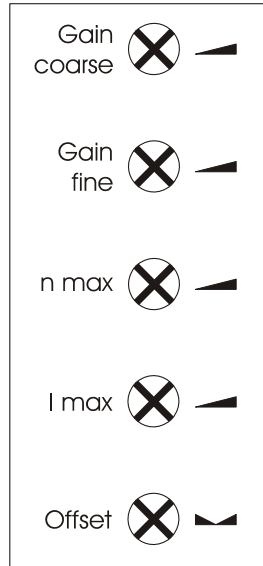

Potentiometer	Function	Turning to the Left (ccw)	Turning to the Right (cw)
<i>Gain coarse</i>	Gain	Factor lowered	Factor raised
<i>Gain fine</i>	Gain	Factor lowered	Factor raised
<i>n max</i>	Definition of max. number of revolutions	Value is decreased	Value is increased
<i>I max</i>	Set value for max. current	Upper limit lowered	Upper limit raised
<i>Offset</i>	Zero Offset (motor stands still)	Motor rotates counterclockwise	Clockwise rotation

Potentiometer setting for start up:

<i>Gain coarse</i>	<i>Gain fine</i>	<i>n max</i>	<i>I max</i>	<i>Offset</i>
Left stop	Middle	Middle	Middle	Middle

5.3 Jumpers

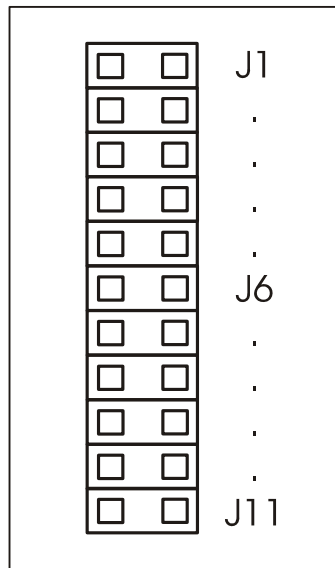

J1	Phasing	Setting of the Hall arrangement
Open	<i>Phase 120°</i>	The halls in the motor have an arrangement of 120°.
Set	<i>Phase 60°</i>	The halls in the motor have an arrangement of 60°.

J2	Timing	Setting of the hall sensor timing
Open	<i>Timing 2</i>	Sets the timing to one of the two possible options. This setting has to be used if it isn't possible to control the motor.
Set	<i>Timing 1</i>	Changes direction of rotation for the electrical field in motor to the opposite of <i>Timing 1</i> .

J3	Set value.	Methods of entering the set value
Open	<i>Set val. extern</i>	External selection using a voltage between XC/16 and XC/17.
Set	<i>Set val. intern</i>	The internal <i>Offset</i> potentiometer is used.

J4	J5	J6	J7	J8	J9	Function Mode
Open	Open	Open	Set	Set	Set	Speed Control by Hall
Open	Set	Set	Set	Open	Open	Speed Control by Encoder
Set	Open	Open	Open	Open	Open	Torque Control

J10	J11	Select max. RPM
Open	Open	Maximum speed range of e.g. 40000 rpm at a 2-pol motor.
Open	Set	Maximum speed is set to 1/2.
Set	Open	Maximum speed is set to 1/4.
Set	Set	Maximum speed is set to 1/8.

6. Glossary

Gain coarse; Gain fine

The dynamical behaviour of the servo amplifier must be compatible to the particular connected motor. The adjusting procedure is performed using the *Gain* potentiometers. A bad adaptation (i.e. if the *Gain* value has been selected too high) can be easily recognized by excessive motor vibration or noise. Consequential mechanical damages cannot be excluded; furthermore an overtemperature situation may arise, due to high currents inside the motor.

When setting the gain value during a stop, the result most probably will have to be accommodated one more time, because the dynamical reaction of the motor at a higher speed will not be sufficient.

Always remember that these potentiometers do not only act on the gain itself, but also on the frequency of the entire control loop.

n max

Use this potentiometer to adapt the desired maximum speed to the amplitude of the present set value. For Example: if maximum of 5V is to be used for maximum Speed then send 5V and adjust that maximum with the *n max* potentiometer.

Take care not to exceed meaningful limits. An exaggerated value may entail problems for the control of the servo amplifier, making it impossible e.g. to line-up the system in speed control operation under load.

I max

The following action requires the motor to be operated with maximum load. The motor current may be measured e.g. using current probe with effective value display, or by means of an ammeter located in the motor line.

I max decide the maximum possible motor current.

The following limits have to be observed:

- Left stop: 5 % of rated current of 10A
- Right stop: 100 % of rated current + (0 – +10 %)

Note:



Do not overheat the motor. For this reason, the *I max* limit should always be selected lower than the maximum admissible constant current.

Offset

There are two distinct functions for the *Offset*-Potentiometer:

1. Levelling the position at which the motor stands still.
2. Selection of the Set Value. This task requires the jumper J3 (*Set value.*) is set. In any mode, this feature is available and offers the possibility of a quick functional test.

It is advisable to begin the subsequent levelling procedure with an idle run of the motor. However you cannot expect this calibration to be stable in the long term, because the motor as well as the controller are always subject to thermal influences.

Hall mode

This is a closed loop speed mode which is using the hall signals as a feedback input for the speed.

Encoder mode

This is a closed loop speed mode that receives the speed information from the encoder. The advantage of a better speed regulation is given especially at lower speed.

Torque mode

In this mode the driver controls only the current into the motor. The speed of the motor depends on the load because only the output force of the motor is regulated.

Brushless motor

A Class of motors that operate using electronic commutation of phase currents, rather than electromechanical (brush-type) commutation. Brushless motors typically have a permanent magnet rotor and a wound stator.

Commutation

Is a term which refers to the action of steering currents or voltages to the proper motor phases so as to produce optimum motor torque. In brush type motors, commutation is done electromechanically via the brushes and commutator. In brushless motors, commutation is done by the switching electronics using rotor position information obtained by Hall sensors.

Hall sensor

Is a feedback device which is used in a brushless servo system to provide information for the amplifier to electronically commutate the motor. The device uses a magnetized wheel and hall effect sensors to generate the commutation signals.

Encoder

Is a feedback device which converts mechanical motion into electronic signals. The most commonly used, rotary encoders, output digital pulses corresponding to incremental angular motion. For example, a 1000-line encoder produces 1000 pulses every mechanical revolution. The encoder consists of a glass or metal wheel with alternating transparent and opaque stripes, detected by optical sensors to produce the digital outputs.

Back EMF

The voltage generated when a permanent magnet motor is rotated. This voltage is proportional to motor speed and is present regardless of whether the motor winding(s) are energized or de-energized.

Closed loop

This is broadly applied term, relating to any system in which the output is measured and compared to the input. The output is then adjusted to reach the desired condition. In motion control, the term typically describes a system utilizing a velocity and/or position transducer to generate correction signals in relation to desired parameters.

Cogging

A term used to describe non-uniform angular velocity. Cogging appears as jerkiness, especially at low speeds.

Continuous rated current

The maximum allowable continuous current a motor can handle without exceeding the motor temperature limits

Continuous stall torque

Is the amount of torque at zero speed, which a motor can continuously deliver without exceeding its thermal rating. To determined by applying DC current through two windings

with locked rotor, while monitoring temperature. It's specified with motor windings at maximum rated temperature and 25 °C ambient temperature, motor mounted to a heat sink. Refer to individual specs for heat sink size.

Controller

This term describes a functional block containing an amplifier, power supplies, and possibly position-control electronics for operating a servomotor or step motor.

Demag current

Is the current level at which the motor magnets will start to be demagnetized. This is an irreversible effect, which will alter the motor characteristics and degrade performance.

Drive

It's an electronic device that controls torque, speed and/or position of an AC or brushless motor. Typically a feedback device is mounted in or on the motor for closed-loop control of velocity and position.

Driver

Is the electronics which convert step and direction inputs to high power currents and voltages to drive a step motor. The step motor driver is analogous to the servomotor amplifier's logic.

Efficiency

The ratio of power output to power input.

Feedback

It is a signal which is transferred from the output back to the input for use in a closed loop system.

Four quadrants

Refers to a motion system which can operate in all four quadrants; i.e., velocity in either direction and torque in either direction. This means that the motor can accelerate, run, and decelerate in either direction.

Inductance

The electrical equivalent to mechanical inertia; that is, the property of a circuit, which has a tendency to resist current flow when no current is flowing, and when current is flowing has a tendency to maintain that current flow.

NTC - Negative Temperature Coefficient

A negative temperature coefficient thermistor is used to detect and protect a motor winding from exceeding its maximum temperature rating it is also used in a servo amplifier. Resistance of the device decreases with an increase in temperature.

Open-loop

A system in which there is no feedback. Motor motion is expected to faithfully follow the input command. Stepping motor systems are an example of open-loop control.

Pulse Width Modulation (PWM)

1. A PWM controller (amplifier) switches DC supply voltage on and off at fixed frequencies. The length of the on/off interval or voltage waveform is variable.
2. Pulse width modulation (PWM), describes a switch-mode (as opposed to linear) control technique used in amplifiers and drivers to control motor voltage and current. PWM offers greatly improved efficiency compared to linear techniques.

Regeneration

The action during motor braking, in which the motor acts as a generator and takes kinetic energy from the load, converts it to electrical energy, and returns it to the amplifier.

Resonance

Oscillatory behavior caused by mechanical limitations.

Ringling

Is an oscillation of a system following a sudden change in state.

Speed

Describes the linear or rotational velocity of a motor or other object in motion.

Tachometer

A small generator normally used as a rotational speed sensing device. The tachometer feeds its signal to a control which adjusts its output to the motor accordingly (called "closed loop feedback" control).

Thermal protection

A thermal sensing device mounted to the motor to protect it from overheating. This is accomplished by disconnecting the motor phases from the drive in an over temperature condition.

Torque

Is a measure of angular force which produces rotational motion. This force is defined by a linear force multiplied by a radius; e.g. lb-in or Nm. Torque is an important parameter of any motion control system.

Two Quadrants

Refers to a motion system which can operate in two quadrants by changing the direction of the motor speed ore in one quadrant with active accelerate and decelerate.

Watt

One horsepower equals 746 watts.

7. Description of Inputs and Outputs

7.1 Digital Inputs

Enable: Activating or Disabling the Output Stage

If the *Enable* input is at GND potential or not wired at all, the output stage remains in the locked state. The motor stands still or slow down without brake. To reactivate the output stage, a voltage signal $>8\text{ V}$ to the *Enable* input XB/13 is necessary.

Additional information about the schematic refer chapter 3.2.

Range of Input Voltage	0 to +30 VDC
Input Impedance	4.7 kOhm to GND
<i>Enable</i> activated	$>8\text{ VDC}$
<i>Enable</i> disabled	open or connected to GND

Hall A / B / C: Hall Feedback of the Motor

The hall inputs XB/10, XB/11 and XB/12 are connected to the hall signal of the motor. The supply voltage is given by the +5V output at XB/6 to GND. The drive needs the signals to do the commutation and control the speed.

Additional information about the schematic refer chapter 3.2.

Range of Input Voltage	0 to +5 VDC
Input Impedance	1 kOhm to +5V
Permanent Input Protection	-5 to +10 VDC
High level	$>2,4\text{ VDC}$
Low level	$<1\text{ VDC}$

Encoder A / B: Encoder Feedback of the Motor

The encoder inputs XB/7 and XB/8 are connected to the encoder output of the motor. The supply voltage is given by the +5V output at XB/6 to GND. The drive needs the signals control the speed.

Additional information about the schematic refer chapter 3.2.

Range of Input Voltage	0 to +5 VDC
Input Impedance	1 kOhm to +5V
Input Frequency	max. 100 kHz
Permanent Input Protection	-5 to +10 VDC
High level	>2,4 VDC
Low level	<1 VDC

7.2 Digital Outputs

Ready/Error: Monitoring Output

Whenever a system failure occurs (i.e. overtemperature), the *Ready/Error* output responds (LO position), and the green LED on the front panel is switch off. The drive output stage is switched off and the error will not reset until the user resets the drive by switching the enable input. If the error occurs again the problem still exists.

The output is an open-collector output and via an external pull-up resistor adaptable to the most industrial logics, up to +30 V.

Additional information about the schematic refer chapter 3.2.

Range of Output Voltage	min. 0.4 V at LO – max. 30 V at HI
Output Impedance	>100 Ohm at LO
Permanent Output Current	20 mA max.

Note:



The logical state of this output is clearly visible by the green/red *OK/Fault* LED on the front panel.

7.3 Analog Inputs

+Set value –Set value: Inputs for Set Values

An external +10/-10 V analog signal for speed or for current is entered using +Set value and –Set value inputs. If the effective voltage is 0V, the motor stops. If the effective voltage is positive, the motor moves in one direction. If the input is negative, the motor consequently will be move in the opposite direction.

These inputs are given in form of a differential amplifier, so each of them can be related to ground. This offers the possibility to preset the level control in only one direction.

Additional information about the schematic refer chapter 3.2.

Range of Input Voltage	-10 V to +10 V
Input Impedance	20 kOhm
Permanent Input Protection	-30 V to +30 V



Remark:

To use the internal *Offset* potentiometer as *Set value* source set jumper J3.

As an alternative, the set value can be entered using an external potentiometer (10 kOhm). For this purpose, connect the slide resistance to +Set value, the left stop to -15V and the right stop to +15V. This procedure requires the -Set value input to be bridged to GND.

The admissible range for the set value is limited by the programmed *n max* speed value. In this case, the desired maximum speed can be selected according to the maximum input voltage. If the motor does not stop at input voltage = 0 V, fine tuning has to be performed using *Offset* potentiometer.

7.4 Analog Outputs

Monitor n: Motor Speed Output

This feature shows the motor speed as a voltage signal. The maximum output voltage depends on the setting of the jumpers J10 and J11 and *n max* potentiometer. After adjusting the *n max* potentiometer at maximum *Set value* (refer chapters 4.x.2) the output goes to 10 V if the maximum speed is reached.

Additional information about the schematic refer chapter 3.2.

Range of Output Voltage	-10 V to +10 V
Output Impedance	10 kOhm
Permanent Output Current	100 μ A max., source and sink

Monitor I: Motor Current Output

Monitor I delivers a result representing the actual value of the peak motor current. The proportionality factor is fixed to 0.5V per 1A motor current.

Additional information about the schematic refer chapter 3.2.

Range of Output Voltage	-10 V to +10 V
Output Impedance	10 kOhm
Permanent Output Current	100 μ A max., source and sink

8. Basic Troubleshooting

The servo amplifier has included some different protective functions. Over voltage, under voltage, over temperature, and over current are monitored and shown with the duo-LED at the front side.



Important:

The motor starts only by resetting the *Enable*. Before resetting an error by resetting the *Enable* make sure that the cause of the failure is eliminated.

Motor oscillates

- The gain of the servo amplifier is too high.

Motor runaway

- Logic of the hall connection is permuted.
- The feedback loop is open. Check wiring.
- No load in torque mode.
- Reduce the maximal speed with pot *n max*.
- Input frequency of feedback has been exceeded.

Motor noise

- Reduce gain with gain pot.
- Use additional choke in the motor

Motor has no torque

- Increase the admissible current with *I max* pot.

Motor drifts at standstill

- Adjust the offset with the offset pot.
- The input value for the set value isn't stable.

Motor is going hot at standstill

- Use an additional choke in series with the motor (see accessories).

Motor speed too low

- Increase the range with pot *n max*.
- Increase the admissible current with *I max* pot.
- Supply voltage too low.
- Encoder input frequency is too high, use an encoder with a lower resolution.

No motion even though the drive is enabled

- Check power supply and the wiring.
- Overheating protection is active.
- Check the timing.
- Is the phasing (120° or 60°) of the hall correct?
- The polarity of the motor windings or hall signals is permuted.
- The feedback loop is open. Check wiring.

Over temperature

- Use an additional heatsink (see accessories).
- Reset the amplifier.

Note:



Beware that the maximal working temperature of 80°C in the driver is not reached; otherwise the drive will be switched off.

9. Accessories & Options

- Mounting adaptor for Din rail ASX-RM-01-01
- Choke modules IA3100 (with 3 x 50 µH)
and IA3101 (with 3 x 100 µH)
- Braking module ASO-BM-70-30

10. Warranties & Disclaimers

- Contents are subject to change without notice.
- Electrocraft will not be liable in any way for direct, indirect, incidental, or consequential damages caused by the use of this product or document.
- Per Electrocraft's Terms & Conditions, the user of Electrocraft's accepts all responsibility and risks involved with applying this product into their machinery and indemnifies Electrocraft against all damages.
- Any reproduction of this product and document is strictly prohibited!

Limited Warranty:

Electrocraft products unless otherwise stated in specifications, are warranted for a period of 18 months from date of shipment, to be free from defects in materials, workmanship, and to conform to the specifications. Liability under this warranty shall be limited to the repair or replacement but not to the installation of any defective product at Seller's option. Products will be repaired or replaced at the Seller's option. Under no circumstance shall the user repair or modify the product. Failure to adhere to this will void all warranty.

For Warranty, Repair, or Technical Assistance contact:

Customer Support, North America / USA & Canada

Motion Control Technologies: (800) 697-6715

Email: info@electrocraft.com

Customer Support, Europe (except Germany), Middle East, Africa, Australia, Central & South America

Customer service at +44 (0) 127 050 8800

Email: EMEAsales@electrocraft.com

Customer Support, Germany

Customer service at +49 (0) 711 727205 0

Email: info@electrocraft.de

11. Dimensions

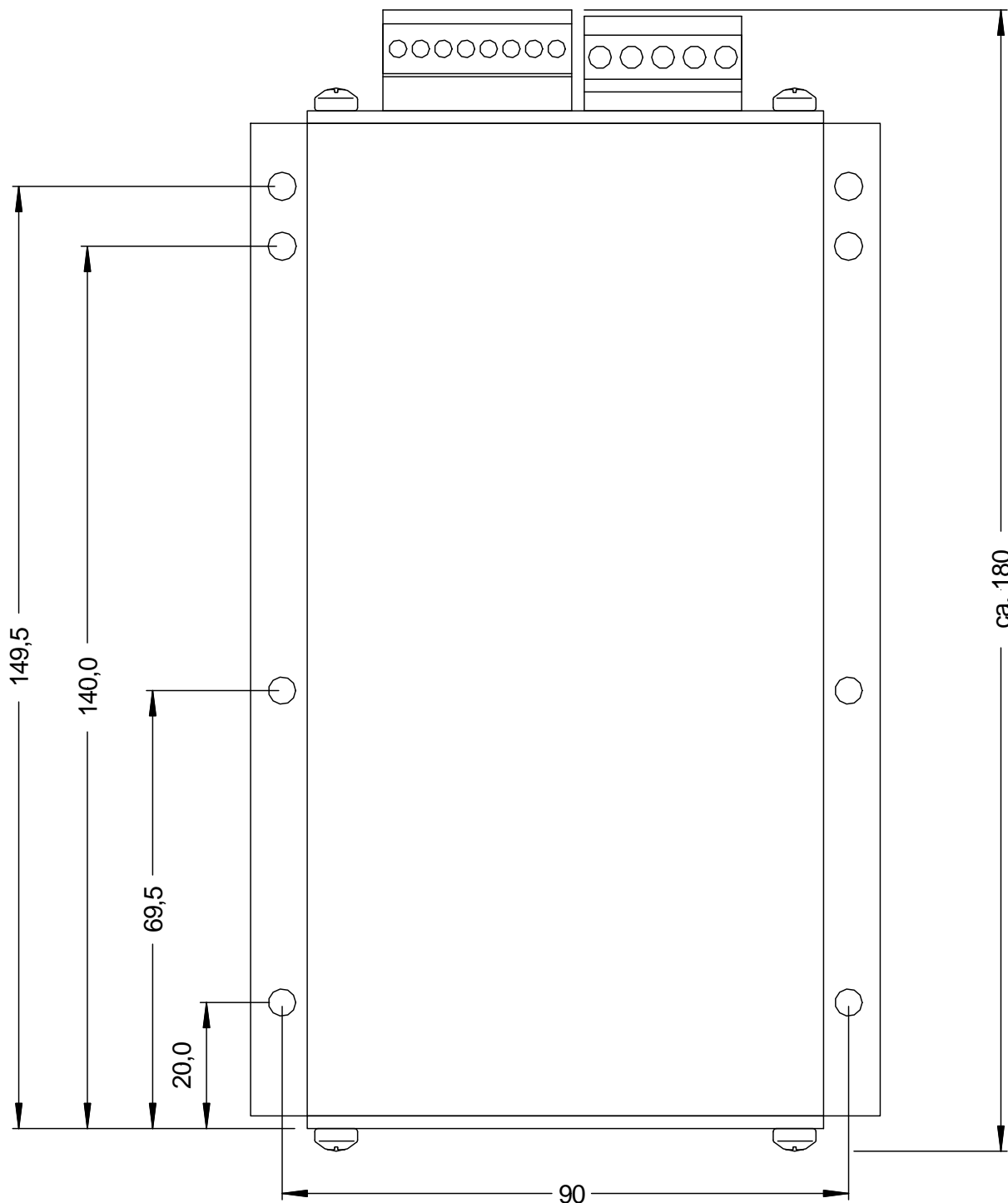

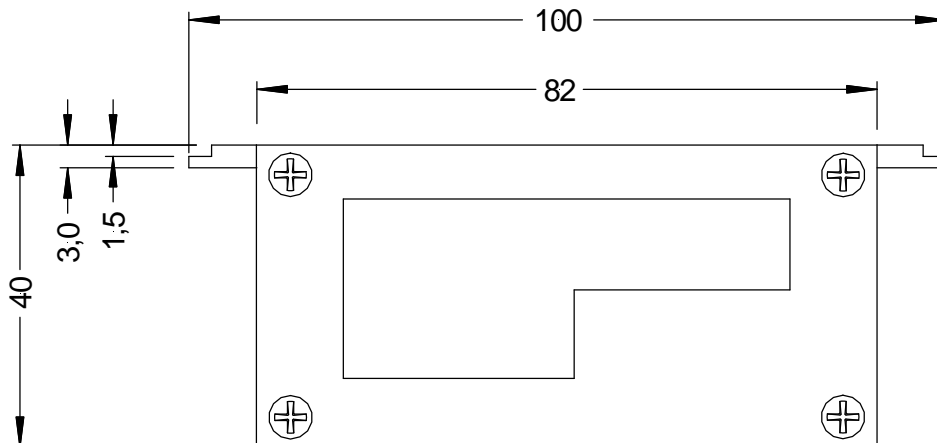

All dimensions in mm.

12. Mounting Din rail adapter

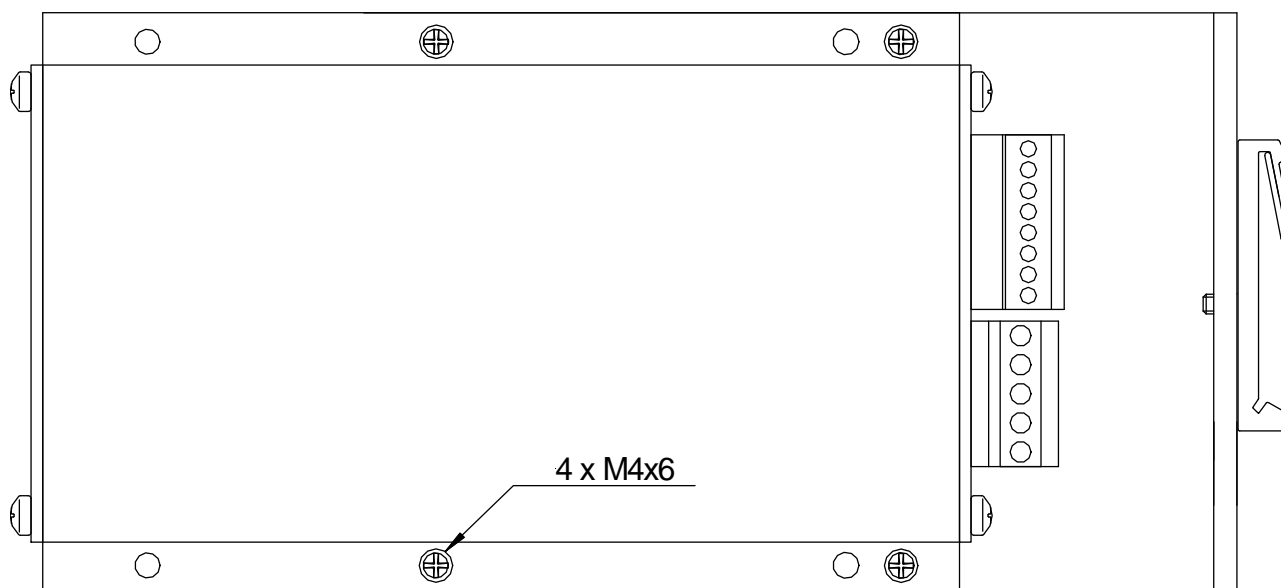

SCO-B4-70-10_E09 Subject to change without prior notice.