

# **ELEKTROWRZECIONA**

**Elementy budowy maszyn i urządzeń przemysłowych**

**[www.akcesoria.cnc.info.pl](http://www.akcesoria.cnc.info.pl)**

**Akcesoria CNC**







**16-300 Augustów**

**ul. Klubowa 4**

**e-mail: [biuro@cnc.info.pl](mailto:biuro@cnc.info.pl)**

**tel/fax: +48 87 644 36 76**

**tel: 602 726 995**

Page	Type	INDICE <i>Index</i>	Range di potenza (Kw)	Range di velocità (rpm)
3		<b>Serie KNS21</b>	0.10 ÷ 0.55	6000 ÷ 18000
5		<b>Serie STK21</b>	0.13 ÷ 0.75	6000 ÷ 18000
7		<b>Serie EVS31/40</b>	0.13 ÷ 2.20	3000 ÷ 18000
10		<b>Serie PE0 TMPE0</b>	0.10 ÷ 0.40	6000 ÷ 24000
12		<b>Serie PE1-2 TM PE1-2</b>	0.10 ÷ 0.75	3000 ÷ 24000
16		<b>Serie PE3 TM PE3</b>	0.15 ÷ 2.20	3000 ÷ 24000
20		<b>Serie PE4 TM PE4</b>	0.65 ÷ 5.60	3000 ÷ 24000
24		<b>Serie PE5 TM PE5</b>	1.25 ÷ 7.00	3000 ÷ 24000
27		<b>Serie TM PE6</b>	3.40 ÷ 9.50	3000 ÷ 18000
29		<b>BIALBERO</b> <i>Double ended shaft</i>	0.15 ÷ 7.00	3000 ÷ 18000
34		<b>Serie SQUADRATICI</b> <i>Panel Sizing</i>	0.65 ÷ 16.00	3000 ÷ 6000
40		<b>Motori SERIE S</b> <i>Seghe Circolari</i> <i>Circular Saws</i>	2.90 ÷ 19.00	1500 ÷ 6000
45		<b>Serie Elettromandrini TMA</b> <i>Cambio utensile automatico</i> <i>Automatic tool change</i> <i>electric spindles</i>	3.60 ÷ 11.00	12000 ÷ 30000
50		<b>Serie AF</b> <i>Eletr. raffreddati a liquido</i> <i>Liquid cooled electric spindles</i>	0.25 ÷ 8.50	24000 ÷ 40000
65		<b>Serie Convertitori Statici</b> <i>Inverter</i>	0.55 ÷ 60.00	
73		<b>RICAMBI</b> <i>Spare Parts</i>		

## Bilanciatura Balance

- **Bilanciatura Standard con 1/2 chiavetta per utensile ad una cava**

*Standard balance with half key for one slot tool.*

- **A richiesta bilanciatura con chiavetta intera per utensile a due cave**

*On request balance with full key for two slot tool.*

- **Si raccomanda l'uso di utensili bilanciati**

*We strictly recommend the use of balanced tools.*

- **Tutti i motori vengono forniti privi di pressacavo**

*All motors are supplied without the plastic gland.*

- **È importante in sede d'ordine specificare il tipo di motore completo di Tensione, Frequenza, Potenza.**

*When ordering please specify the Voltage, Frequency and Power of the motor.*

- **In tutti i motori sono montati cuscinetti per alte velocità ingrassati a vita.**

*All motors have bearings for high speeds and do not require any additional lubrication.*

- **Tutti i motori sono a normativa europea (marchio CE).**

*All motors conform to the European CE standard.*

- **Direttiva macchine (89/392/CEE).**

*All motors conform to the "machines" directive (89/392/CEE).*

- **Direttiva compatibilità elettromagnetica EMC (89/336/CEE).**

*All motors conform to the electromagnetic compatibility directive EMC (89/336/CEE).*

- **Direttiva bassa tensione (73/23/CEE).**

*All motors conform to the "low voltage directive" 73/23/CEE.*

- **Tutti i motori (a specifica richiesta) possono essere documentati con bollettini di collaudo funzionale, in fase di certificazione finale.**

*(On request) all motors can be supplied with a functional test certificate, during the final phase of certification.*

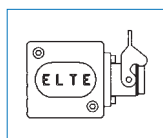

**A richiesta coprimorsettiera in alluminio 57x57 con connettore esterno come da disegno.**

*On request aluminium cable box 57x57 with external connector.*

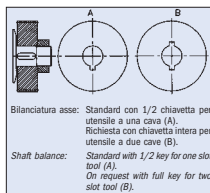

Bilanciatura asse: Standard con 1/2 chiavetta per utensile a una cava (A).  
Richiesta con chiavetta intera per utensile a due cave (B).  
Shaft balance: Standard with 1/2 key for one slot tool (A).  
On request with full key for two slot tool (B).

## Serie KNS

TIPO TYPE	TENSIONE VOLTAGE (VOLT)		FREQU. (HZ)	GIRI (rpm)	POT. RESA OUT. POW. (KW)	ASSORB. ABSORB. (amp)		COS φ	PESO WEIGHT (Kg)		
	Standard	a richiesta on request				Standard	a richiesta on request				
KNS21 6/2	380	220	220/380	100	6000	0.09	0.40	0.7	0.7/0.40	0.65	1.8
KNS21 6/2	220	380	220/380	200	12000	0.16	1.10	0.64	1.10/0.64	0.70	1.8
KNS21 6/2	380	220	220/380	300	18000	0.22	1.00	1.73	1.73/1.00	0.70	1.8
KNS21 7/2	380	220	220/380	100	6000	0.11	0.49	0.85	0.85/0.49	0.65	2
KNS21 7/2	220	380	220/380	200	12000	0.22	1.50	0.85	1.50/0.85	0.70	2
KNS21 7/2	380	220	220/380	300	18000	0.33	1.20	2.10	2.10/1.20	0.70	2
KNS21 8.5/2	380	220	220/380	100	6000	0.22	0.86	1.50	1.50/0.86	0.65	2.5
KNS21 8.5/2	220	380	220/380	200	12000	0.37	2.30	1.30	2.30/1.30	0.70	2.5
KNS21 8.5/2	380	220	220/380	300	18000	0.55	1.85	3.20	3.20/1.85	0.70	2.5

- Per Tensioni 230/400 VOLT l'assorbimento amperometrico va moltiplicato per 0.95.
- For Voltages 230/400 the amps ABS. has to be multiplied by 0.95.

## Motori KNS21

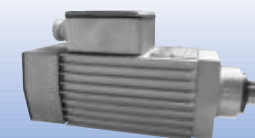
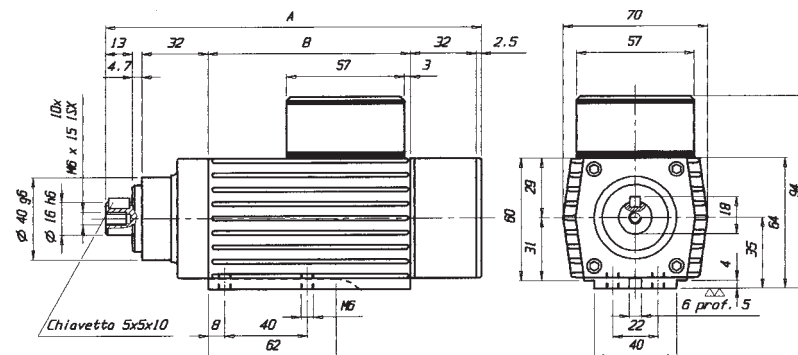

TIPO Type	A	B
KNS21 6/2	182	98
KNS21 7/2	182	98
KNS21 8.5/2	217	133

**Sporgenza SC**  
Nose type SC



## Motori KNS21

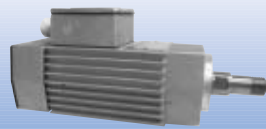
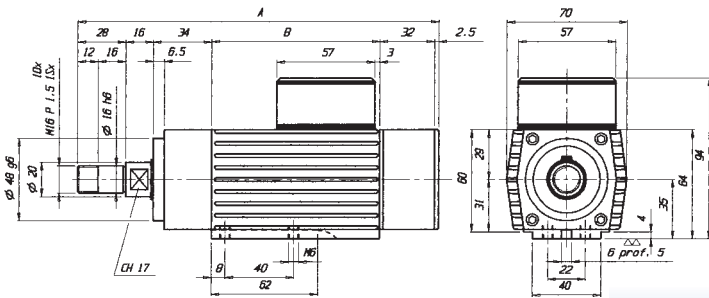

TIPO Type	A	B
KNS21 6/2	210.5	98
KNS21 7/2	210.5	98
KNS21 8.5/2	245.5	133

**Sporgenza SF**  
Nose type SF

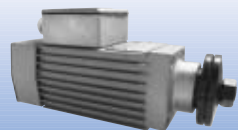
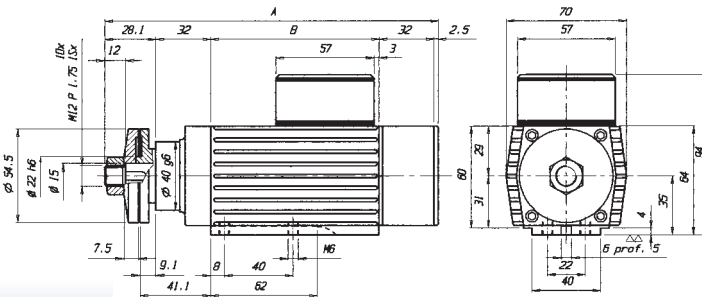

TIPO Type	A	B
KNS21 6/2	192.5	98
KNS21 7/2	192.5	98
KNS21 8.5/2	227.5	133

**Sporgenza SCF**  
Nose type SCF



## Serie STK

TIPO TYPE	TENSIONE VOLTAGE (VOLT)		FREQU. (HZ)	GIRI (rpm)	POT. RESA OUT. POW. (KW)	ASSORB. ABSORB. (amp)		COS $\phi$	PESO WEIGHT (Kg)		
	Standard	a richiesta on request				Standard	a richiesta on request				
STK21 6.5/2	380	220	220/380	100	6000	0.13	0.58	1.00	1.00/0.58	0.63	1.8
STK21 6.5/2	220	380	220/380	200	12000	0.35	2.00	1.16	2.00/1.16	0.69	1.8
STK21 6.5/2	380	220	220/380	300	18000	0.41	1.27	2.20	2.20/1.27	0.70	1.8
STK21 9/2	380	220	220/380	100	6000	0.22	0.85	1.47	1.47/0.85	0.65	2
STK21 9/2	220	380	220/380	200	12000	0.55	2.55	1.50	2.55/1.50	0.70	2
STK21 9/2	380	220	220/380	300	18000	0.75	2.14	3.70	3.70/2.14	0.71	2

- Per Tensioni 230/400 VOLT l'assorbimento amperometrico va moltiplicato per 0.95.
- For Voltages 230/400 the amps ABS. has to be multiplied by 0.95.

## Motori STK21

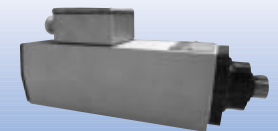
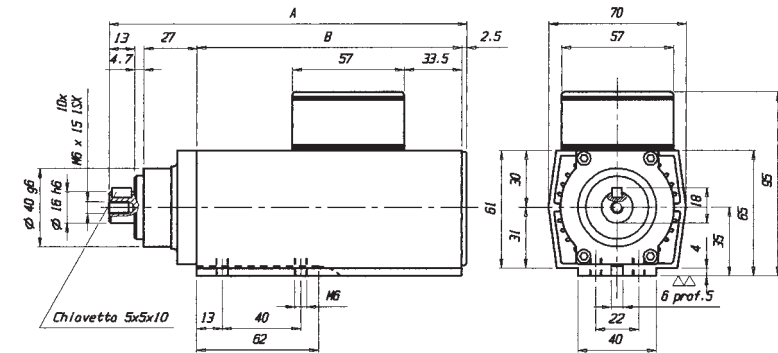

TIPO Type	A	B
STK21 6.5/2	182	135
STK21 9/2	217	170

**Sporgenza SC**  
Nose type SC





## Motori EVS31

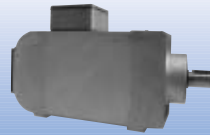
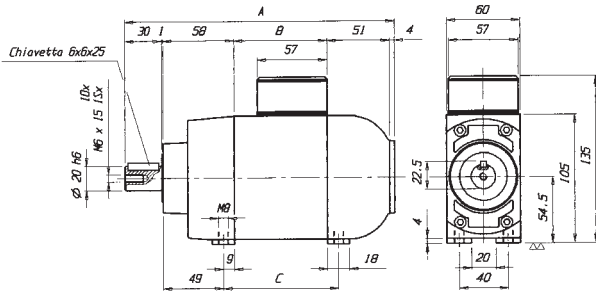

TIPO Type	A	B	C
EVS31 6.5/2	215	71	90
EVS31 9/2	245	101	120

**Sporgenza SC**  
Nose type SC



## Motori EVS40

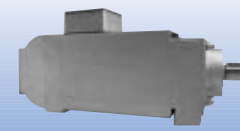
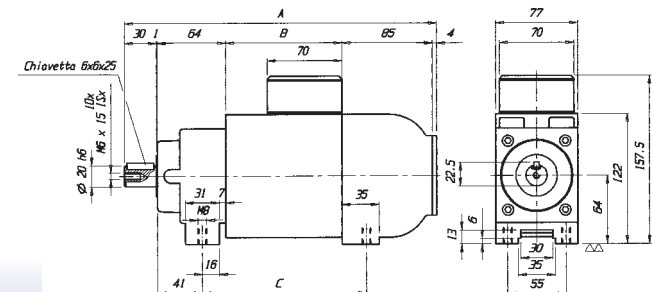

TIPO Type	A	B	C
EVS40 9/2	288	104	150
EVS40 12/2	348	164	210
EVS40 14/2	348	164	210

**Sporgenza SC**  
Nose type SC

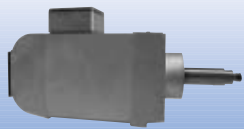
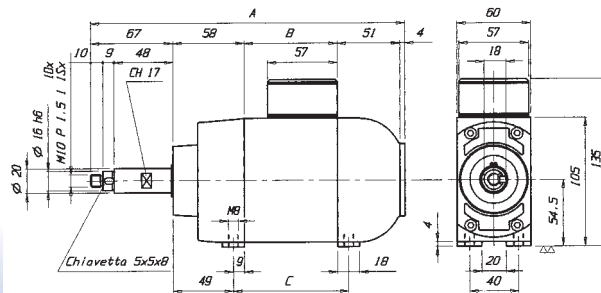

TIPO Type	A	B	C
EVS31 6.5/2	251	71	90
EVS31 9/2	281	101	120

**Sporgenza SLF**  
Nose type SLF

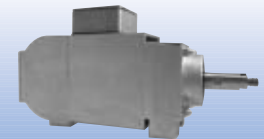
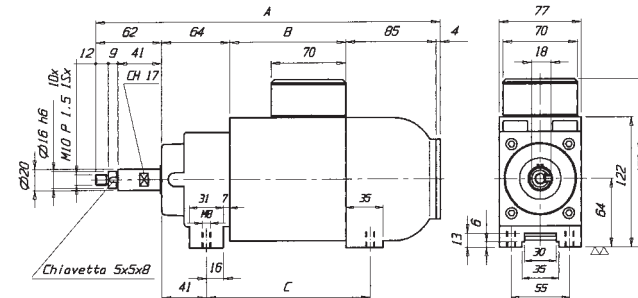

TIPO Type	A	B	C
EVS40 9/2	319	104	150
EVS40 12/2	379	164	210
EVS40 14/2	379	164	210

**Sporgenza SLF**  
Nose type SLF



## .Serie PEO TMPEO

TIPO TYPE	TENSIONE VOLTAGE (VOLT)			FREQU. (HZ)	GIRI (rpm)	POT. RESA OUT. POW. (KW)		ASSORB. ABSORB. (amp)		COS φ	PESO WEIGHT (Kg)
	Standard	a richiesta on request				Standard	a richiesta on request				
PEO 3.5/2	220	380	220/380	200	12000	0.08	0.60	0.34	0.60/0.34	0.65	1.2
PEO 3.5/2	380	220	220/380	300	18000	0.12	0.45	0.78	0.78/0.45	0.69	1.2
PEO 6/2	380	220	220/380	100	6000	0.05	0.26	0.45	0.45/0.26	0.61	1.5
PEO 6/2	220	380	220/380	200	12000	0.15	0.80	0.45	0.80/0.45	0.68	1.5
PEO 6/2	380	220	220/380	300	18000	0.30	1.00	1.70	1.70/1.00	0.70	1.5
PEO 7.5/2	380	220	220/380	100	6000	0.07	0.32	0.55	0.55/0.32	0.61	1.8
PEO 7.5/2	220	380	220/380	200	12000	0.18	1.20	0.69	1.20/0.69	0.64	1.8
PEO 7.5/2	380	220	220/380	300	18000	0.35	1.00	1.70	1.70/1.00	0.70	1.8

Per frequenze superiori contattare ns. ufficio tecnico.  
For higher frequencies please contact our technical dept.

TMPEO 3.5/2	220	380	220/380	200	12000	0.08	0.60	0.34	0.60/0.34	0.65	1.4
TMPEO 3.5/2	380	220	220/380	300	18000	0.12	0.45	0.78	0.78/0.45	0.69	1.4
TMPEO 3.5/2	380	220	220/380	400	24000	0.15	0.52	0.90	0.90/0.52	0.70	1.4
TMPEO 6/2	380	220	220/380	100	6000	0.05	0.26	0.45	0.45/0.26	0.61	1.7
TMPEO 6/2	220	380	220/380	200	12000	0.15	0.80	0.45	0.80/0.45	0.68	1.7
TMPEO 6/2	380	220	220/380	300	18000	0.30	1.00	1.70	1.70/1.00	0.70	1.7
TMPEO 6/2	380	220	220/380	400	24000	0.35	1.10	1.90	1.90/1.10	0.70	1.7
TMPEO 7.5/2	380	220	220/380	100	6000	0.07	0.32	0.55	0.55/0.32	0.61	2
TMPEO 7.5/2	220	380	220/380	200	12000	0.18	1.20	0.69	1.20/0.69	0.64	2
TMPEO 7.5/2	380	220	220/380	300	18000	0.35	1.00	1.70	1.70/1.00	0.70	2
TMPEO 7.5/2	380	220	220/380	400	24000	0.40	1.20	2.10	2.10/1.20	0.70	2

- Per Tensioni 230/400 VOLT l'assorbimento amperometrico va moltiplicato per 0.95.
- For Voltages 230/400 the amps ABS. has to be multiplied by 0.95.

## .Motori PEO

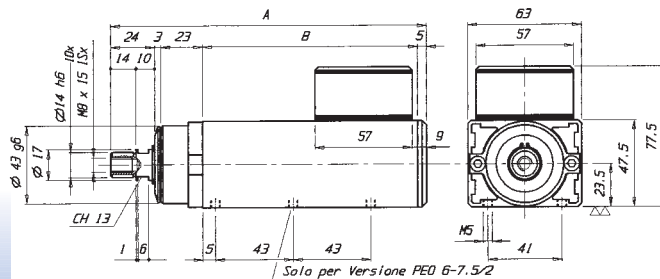

## .Motori PEO

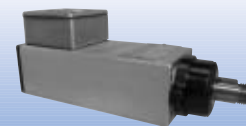
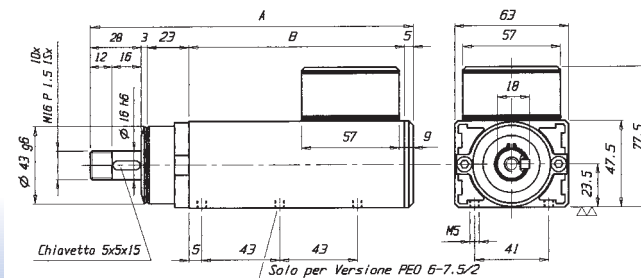

TIPO Type	A	B
PEO 3.5/2	178	119
PEO 6/2	203	144
PEO 7.5/2	218	159

Sporgenza SF  
Nose type SF

## Motori TM PEO

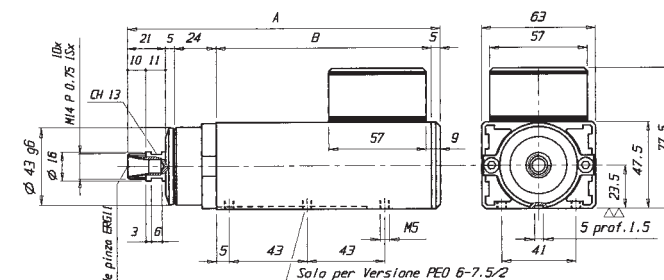

Ghiera ER 11  
Ring nut ER 11

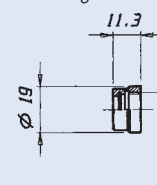

Pinza ER 11  
Collet ER 11

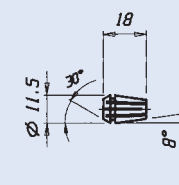

Diametro Min. 1 Max. 7 mm.  
Diameter Min. 1 Max. 7 mm.

NB: Pinza e ghiera vengono fornite a richiesta.  
NB: Collet and ring nut only on your request.

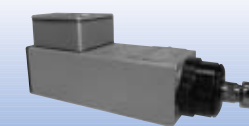

TIPO Type	A	B
TMPEO 3.5/2	174	119
TMPEO 6/2	199	144
TMPEO 7.5/2	214	159

Sporgenza per pinza  
ER 11  
Nose type for collet ER 11



## Serie PE1-2 TM PE1-2.

TIPO TYPE	TENSIONE VOLTAGE (VOLT)		FREQU. (HZ)	GIRI (rpm)	POT. RESA OUT. POW. (KW)	ASSORB. ABSORB. (amp)		COS φ	PESO WEIGHT (Kg)		
	Standard	a richiesta on request				Standard	a richiesta on request				
PE1 6/2	380	220	220/380	100	6000	0.07	0.25	0.43	0.43/0.25	0.70	2.5
PE1 6/2	220	380	220/380	200	12000	0.16	1.35	0.78	1.35/0.78	0.70	2.5
PE1 6/2	380	220	220/380	300	18000	0.22	1.25	2.20	2.20/1.25	0.70	2.5
PE1 7/2	380	220	220/380	100	6000	0.10	0.40	0.70	0.70/0.40	0.70	2.8
PE1 7/2	220	380	220/380	200	12000	0.22	1.65	0.95	1.65/0.95	0.70	2.8
PE1 7/2	380	220	220/380	300	18000	0.33	1.40	2.40	2.40/1.40	0.70	2.8
PE1 8.5/2	380	220	220/380	100	6000	0.22	0.78	1.35	1.35/0.78	0.68	3.1
PE1 8.5/2	220	380	220/380	200	12000	0.37	2.00	1.15	2.00/1.15	0.69	3.1
PE1 8.5/2	380	220	220/380	300	18000	0.55	1.73	3.00	3.00/1.73	0.70	3.1
PE2 9/2	220/380	220	380	50	3000	0.10	0.85/0.50	0.85	0.50	0.60	3.5
PE2 9/2	380	220	220/380	100	6000	0.22	0.85	1.47	1.47/0.85	0.65	3.5
PE2 9/2	220	380	220/380	200	12000	0.55	2.60	1.50	2.60/1.50	0.73	3.5
PE2 9/2	380	220	220/380	300	18000	0.75	2.15	3.70	3.70/2.15	0.71	3.5
Per frequenze superiori contattare ns. ufficio tecnico. For higher frequencies please contact our technical dept.											
TMPE1 6.5/2	380	220	220/380	100	6000	0.10	0.40	0.70	0.70/0.40	0.70	3.3
TMPE1 6.5/2	220	380	220/380	200	12000	0.22	1.65	0.95	1.65/0.95	0.70	3.3
TMPE1 6.5/2	380	220	220/380	300	18000	0.33	1.40	2.40	2.40/1.40	0.70	3.3
TMPE1 6.5/2	380	220	220/380	400	24000	0.40	1.4	2.40	2.40/1.40	0.72	3.3
TMPE2 9/2	220/380	220	380	50	3000	0.10	0.85/0.50	0.85	0.50	0.60	3.7
TMPE2 9/2	380	220	220/380	100	6000	0.20	0.85	1.47	1.47/0.85	0.65	3.7
TMPE2 9/2	220	380	220/380	200	12000	0.55	2.60	1.50	2.60/1.50	0.73	3.7
TMPE2 9/2	380	220	220/380	300	18000	0.75	2.15	3.70	3.70/2.15	0.71	3.7
TMPE2 9/2	380	220	220/380	400	24000	0.75	2.40	4.1	4.1/2.40	0.71	3.7

- Per Tensioni 230/400 VOLT l'assorbimento amperometrico va moltiplicato per 0.95.
- For Voltages 230/400 the amps ABS. has to be multiplied by 0.95.



## Motori PE1-2

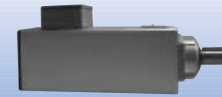
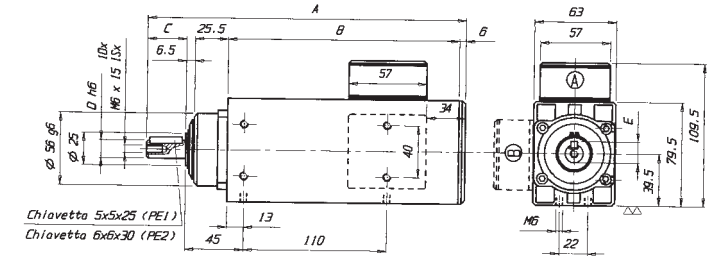

TIPO Type	A	B	C	D	E
PE1 6/2	246	178	30	14	16
PE1 7/2	246	178	30	14	16
PE1 8.5/2	246	178	30	14	16
PE2 9/2	275	197	40	20	22.5

**Sporgenza SC**  
Nose type SC

**NB:** Posizione morsetteria standard come da posizione "A" con forature lato stretto. Su richiesta in posizione "B" con forature lato largo.

**NB:** Standard terminal box in "A" position with fixing holes on narrow part. On request terminal box in "B" position with fixing holes on wide part.

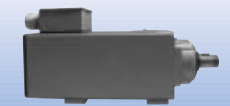
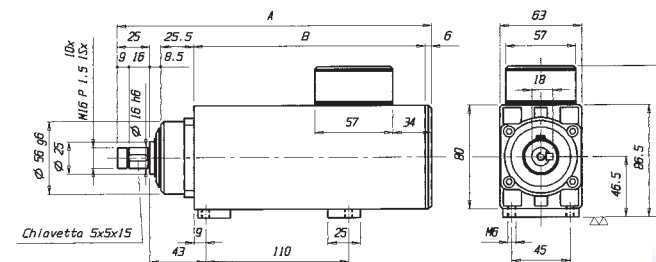

TIPO Type	A	B
PE1 6/2	243	178
PE1 7/2	243	178
PE1 8.5/2	243	178
PE2 9/2	262	197

**Sporgenza SF**  
Nose type SF





## Motori PE1-2

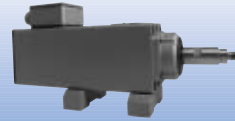
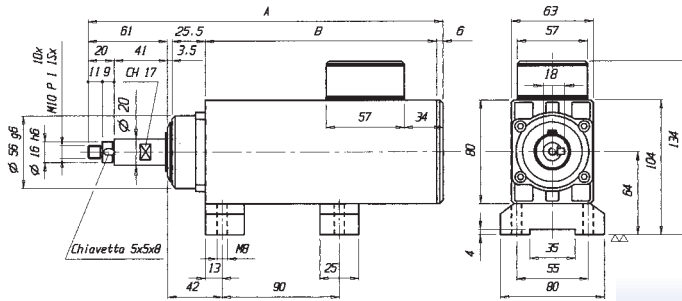

TIPO Type	A	B
PE1 6/2	274	178
PE1 7/2	274	178
PE1 8.5/2	274	178
PE2 9/2	293	197

**Sporgenza SLF**  
Nose type SLF



## Motori TM PE1-2

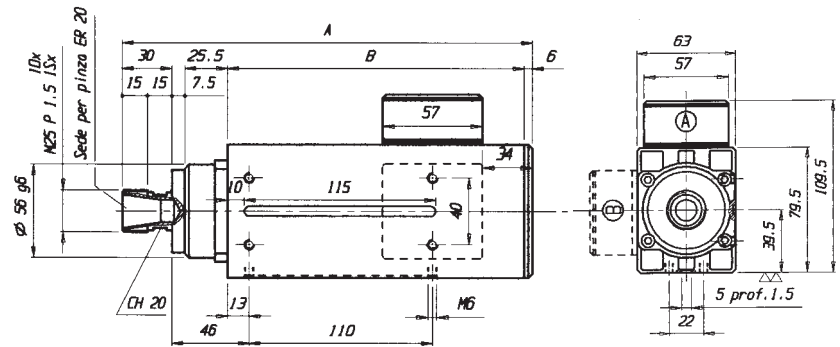

**NB:** Posizione morsetteria standard come da posizione "A" con forature lato stretto. Su richiesta in posizione "B" con forature lato largo.

**NB:** Standard terminal box in "A" position with fixing holes on narrow part. On request terminal box in "B" position with fixing holes on wide part.

**Ghiera ER 20**  
Ring nut ER 20

19

**Pinza ER 20**  
Collet ER 20

31

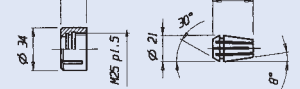

**Diametro Min. 1 Max. 13 mm.**  
Diameter Min. 1 Max. 13 mm.

**NB: Pinza e ghiera vengono fornite a richiesta.**  
NB: Collet and ring nut only on your request.

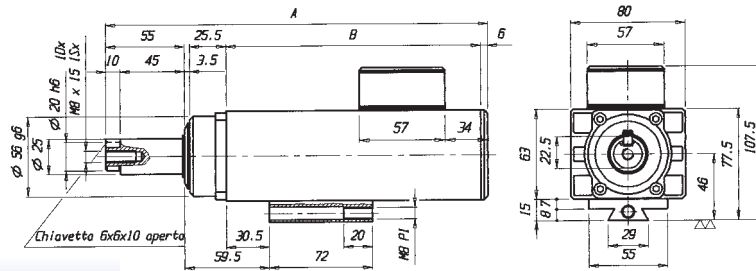

TIPO Type	A	B
PE1 6/2	268	178
PE1 7/2	268	178
PE1 8.5/2	268	178
PE2 9/2	287	197

**Sporgenza SL**  
Nose type SL

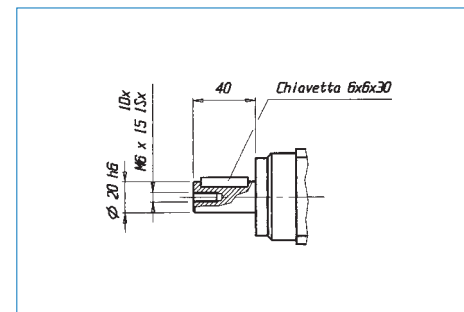

**Versione TM PE1-2 con sporgenza d'albero SC**  
TM PE1-2 version with nose type SC

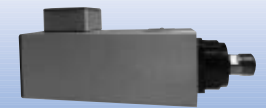

TIPO Type	A	B
TMPE1 6.5/2	254	185
TMPE2 9/2	274	205

**Sporgenza per pinza ER 20**  
Nose type for collet ER 20



## Serie PE3 TM PE3

TIPO TYPE	TENSIONE VOLTAGE (VOLT)		FREQU. (HZ)	GIRI (rpm)	POT. RESA OUT. POW. (KW)	ASSORB. ABSORB. (amp)		COS φ	PESO WEIGHT (Kg)
	Standard	a richiesta on request				Standard	a richiesta on request		
PE3 7/2	220/380	220 380	50	3000	0.15	1.35/0.78	0.35 0.78	0.68	3.7
PE3 7/2	380	220 220/380	100	6000	0.30	1.00	1.73 1.73/1.00	0.68	3.7
PE3 7/2	220	380 220/380	200	12000	0.60	3.41	1.97 3.41/1.97	0.68	3.7
PE3 7/2	380	220 220/380	300	18000	0.85	2.70	4.60 4.60/2.70	0.70	3.7
PE3 9/2	220/380	220 380	50	3000	0.20	1.50/0.90	1.50 0.90	0.70	4.8
PE3 9/2	380	220 220/380	100	6000	0.45	1.40	2.40 2.40/1.40	0.75	4.8
PE3 9/2	220	380 220/380	200	12000	0.75	4.00	2.30 4.00/2.30	0.75	4.8
PE3 9/2	380	220 220/380	300	18000	1.00	3.20	5.50 5.50/3.20	0.75	4.8
PE3 12/2	220/380	220 380	50	3000	0.30	1.70/1.00	1.70 1.00	0.70	6.5
PE3 12/2	380	220 220/380	100	6000	0.75	1.90	3.30 3.30/1.90	0.75	6.5
PE3 12/2	220	380 220/380	200	12000	1.50	6.30	3.60 6.30/3.60	0.79	6.5
PE3 12/2	380	220 220/380	300	18000	2.00	5.20	9.00 9.00/5.20	0.80	6.5
PE3 14/2	220/380	220 380	50	3000	0.45	2.78/1.60	2.78 1.60	0.68	7.5
PE3 14/2	380	220 220/380	100	6000	0.95	2.52	4.36 4.36/2.52	0.73	7.5
PE3 14/2	220	380 220/380	200	12000	1.80	8.20	4.70 8.20/4.70	0.70	7.5
PE3 14/2	380	220 220/380	300	18000	2.20	5.80	10.00 10.00/5.80	0.73	7.5

Per frequenze superiori contattare ns. ufficio tecnico.  
For higher frequencies please contact our technical dept.

TMPE3 9/2	220/380	220 380	50	3000	0.20	1.50/0.90	1.50 0.90	0.70	5.5
TMPE3 9/2	380	220 220/380	100	6000	0.45	1.40	2.40 2.40/1.40	0.75	5.5
TMPE3 9/2	220	380 220/380	200	12000	0.75	4.00	2.30 4.00/2.30	0.75	5.5
TMPE3 9/2	380	220 220/380	300	18000	1.00	3.20	5.50 5.50/3.20	0.75	5.5
TMPE3 9/2	380	220 220/380	400	24000	1	3.20	5.50 5.50/3.20	0.75	5.5
TMPE3 12/2	220/380	220 380	50	3000	0.30	1.70/1.00	1.70 1.00	0.70	8
TMPE3 12/2	380	220 220/380	100	6000	0.75	1.90	3.30 3.30/1.90	0.75	8
TMPE3 12/2	220	380 220/380	200	12000	1.50	6.30	3.60 6.30/3.60	0.79	8
TMPE3 12/2	380	220 220/380	300	18000	2.00	5.20	9.00 9.00/5.20	0.80	8
TMPE3 12/2	380	220 220/380	400	24000	2.2	5.50	9.50 9.50/5.50	0.80	8

- Per Tensioni 230/400 VOLT l'assorbimento amperometrico va moltiplicato per 0.95.
- For Voltages 230/400 the amps ABS. has to be multiplied by 0.95.

## Motori PE3

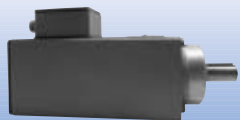

TIPO Type	A	B	C
PE3 7/2	261	180	150
PE3 9/2	281	200	170
PE3 12/2	321	240	170
PE3 14/2	321	240	170

**Sporgenza SC**  
Nose type SC

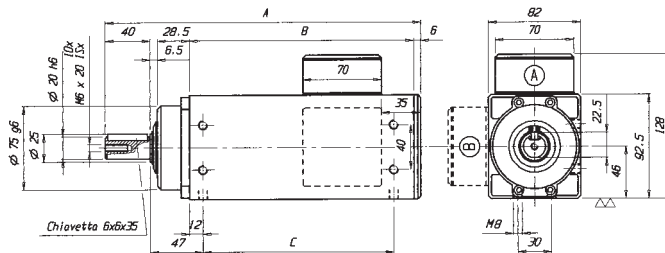

**NB:** Posizione morsettieria standard come da posizione "A" con forature lato stretto. Su richiesta in posizione "B" con forature lato largo.  
NB: Standard terminal box in "A" position with fixing holes on narrow part. On request terminal box in "B" position with fixing holes on wide part.



## Motori Serie PE3

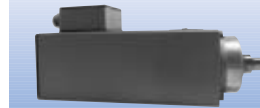
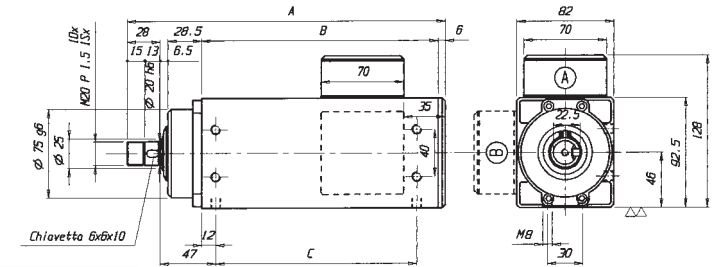

TIPO Type	A	B	C
PE3 7/2	249	180	150
PE3 9/2	269	200	170
PE3 12/2	309	240	170
PE3 14/2	309	240	170

**Sporgenza SF**  
Nose type SF

**NB:** Posizione morsettieria standard come da posizione "A" con forature lato stretto. Su richiesta in posizione "B" con forature lato largo.

NB: Standard terminal box in "A" position with fixing holes on narrow part. On request terminal box in "B" position with fixing holes on wide part.

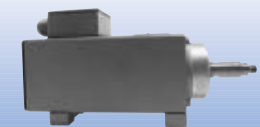
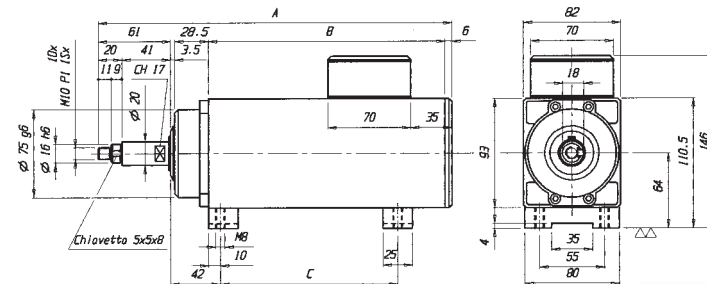

TIPO Type	A	B	C
PE3 7/2	249	180	90
PE3 9/2	299	200	150
PE3 12/2	339	240	150
PE3 14/2	339	240	150

**Sporgenza SLF**  
Nose type SLF



## Motori PE3

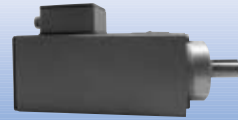
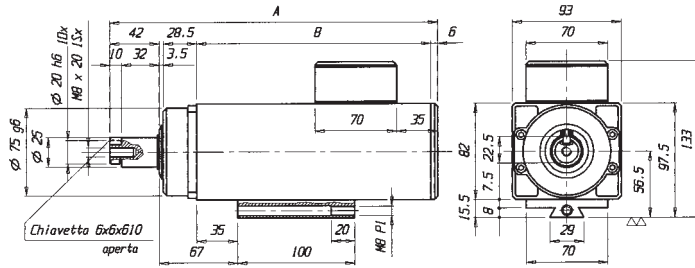

TIPO Type	A	B
PE3 7/2	260	180
PE3 9/2	280	200
PE3 12/2	320	240
PE3 14/2	320	240

**Sporgenza SL**  
Nose type SL

## Motori TM PE3

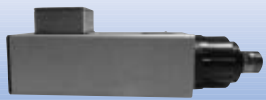
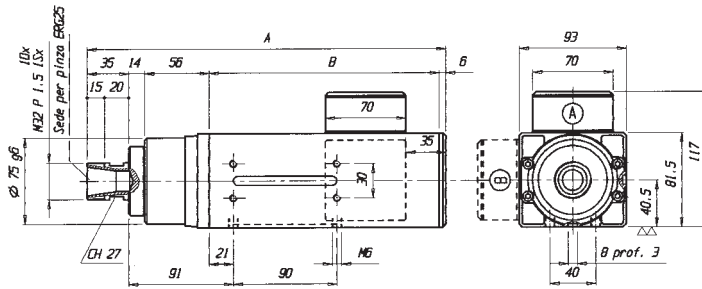

TIPO Type	A	B
TMPE3 9/2	311	200
TMPE3 12/2	351	240

**Sporgenza per pinza ER25**  
Nose type for collet ER 25

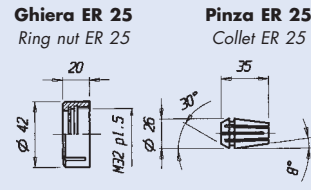

**Ghiera ER 25** Ring nut ER 25  
**Pinza ER 25** Collet ER 25  
Diametro Min. 1 Max. 16 mm.  
Diameter Min. 1 Max. 16 mm.

**NB: Pinza e ghiera vengono fornite a richiesta.**  
NB: Collet and ring nut only on your request.



## Motori TM PE3

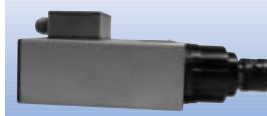
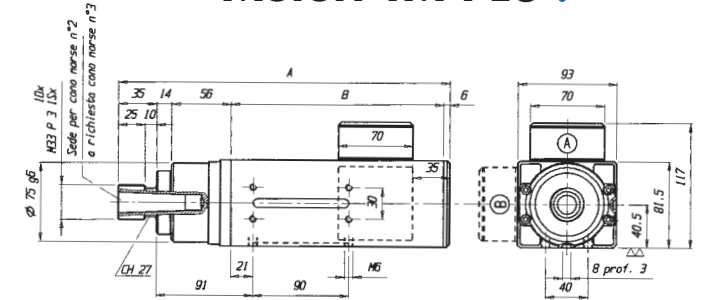

TIPO Type	A	B
TMPE3 9/2	311	200
TMPE3 12/2	351	240

**Sporgenza per Cono Morse 2-3**  
Nose type for MK 2-3

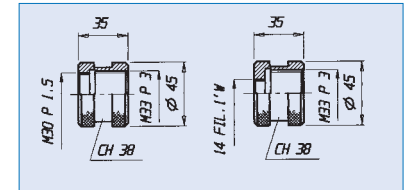

**Ghiera per Cono Morse n° 2-3**  
Collet for MK 2-3

**NB: Pinza e ghiera vengono fornite a richiesta.**  
NB: Collet and ring nut only on your request.

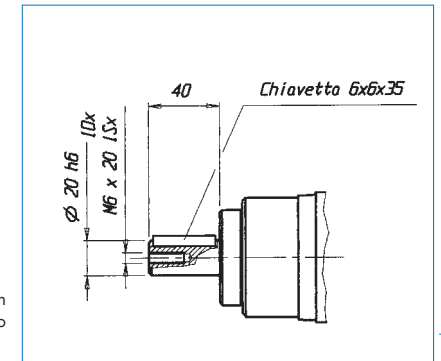

**Versione TM PE3 con sporgenza d'albero SC**  
TM PE3 version with nose type SC

**NB:** Posizione morsetti standard come da posizione "A" con forature lato largo. Su richiesta in posizione "B" con forature lato stretto.

**NB:** Standard terminal box on "A" position with fixing holes on wide part. On request terminal box in "B" position with fixing holes on narrow part.

# Serie PE4 TM PE4

TIPO TYPE	TENSIONE VOLTAGE (VOLT)		FREQU. (HZ)	GIRI (rpm)	POT. RESA OUT. POW. (KW)	ASSORB. ABSORB. (amp)		COS φ	PESO WEIGHT (Kg)	
	a richiesta on request					Standard	a richiesta on request			
	Standard									
PE4 10/2	220/380	220 380	50	3000	0.65	3.30/1.90	3.30 1.90	0.72	9	
PE4 10/2	380	220 220/380	100	6000	1.10	2.80	4.90 4.90/2.80	0.77	9	
PE4 10/2	220	380 220/380	200	12000	2.20	9.70	5.60 9.70/5.60	0.77	9	
PE4 10/2	380	220 220/380	300	18000	3.30	7.90	13.70 13.70/7.90	0.80	9	
PE4 11/2	220/380	220 380	50	3000	0.75	3.50/2.00	3.50 2.00	0.74	9.8	
PE4 11/2	380	220 220/380	100	6000	1.50	3.80	6.60 6.60/3.80	0.75	9.8	
PE4 11/2	220	380 220/380	200	12000	2.60	10.40	6.00 10.40/6.00	0.83	9.8	
PE4 11/2	380	220 220/380	300	18000	3.30	7.80	13.40 13.40/7.80	0.82	9.8	
PE4 13/2	220/380	220 380	50	3000	1.00	4.90/2.85	4.90 2.85	0.77	11.2	
PE4 13/2	380	220 220/380	100	6000	2.00	4.45	7.70 7.70/4.45	0.82	11.2	
PE4 13/2	220	380 220/380	200	12000	3.00	12.50	7.20 12.50/7.20	0.80	11.2	
PE4 13/2	380	220 220/380	300	18000	4.00	9.50	16.40 16.40/9.50	0.80	11.2	
PE414/2	220/380	220 380	50	3000	1.10	5.50/3.15	5.50 3.15	0.72	12	
PE4 14/2	380	220 220/380	100	6000	2.20	5.50	9.50 9.50/5.50	0.77	12	
PE4 14/2	220	380 220/380	200	12000	3.70	15.00	8.70 15.00/8.70	0.78	12	
PE4 14/2	380	220 220/380	300	18000	5.60	11.50	20.00 20.00/11.5	0.85	12	

Per frequenze superiori contattare ns. ufficio tecnico.  
For higher frequencies please contact our technical dept.

TMPE4 10/2	220/380	220 380	50	3000	0.65	3.30/1.90	3.30 1.90	0.72	11.5
TMPE4 10/2	380	220 220/380	100	6000	1.10	2.80	4.90 4.90/2.80	0.77	11.5
TMPE4 10/2	220	380 220/380	200	12000	2.20	9.70	5.60 9.70/5.60	0.77	11.5
TMPE4 10/2	380	220 220/380	300	18000	3.30	7.90	13.70 13.70/7.90	0.80	11.5
TMPE4 10/2	380	220 220/380	400	24000	3.30	7.90	13.70 13.70/7.90	0.80	11.5
TMPE4 14/2	220/380	220 380	50	3000	1.10	5.50/3.15	5.50 3.15	0.72	13.5
TMPE4 14/2	380	220 220/380	100	6000	2.20	5.50	9.50 9.50/5.50	0.77	13.5
TMPE4 14/2	220	380 220/380	200	12000	3.70	15.00	8.70 15.00/8.70	0.78	13.5
TMPE4 14/2	380	220 220/380	300	18000	5.60	11.50	20.00 20.00/11.5	0.85	13.5
TMPE4 14/2	380	220 220/380	400	24000	5.60	11.50	20.00 20.00/11.5	0.85	13.5

- Per Tensioni 230/400 VOLT l'assorbimento amperometrico va moltiplicato per 0.95.
- For Voltages 230/400 the amps ABS. has to be multiplied by 0.95.

# Motori PE4

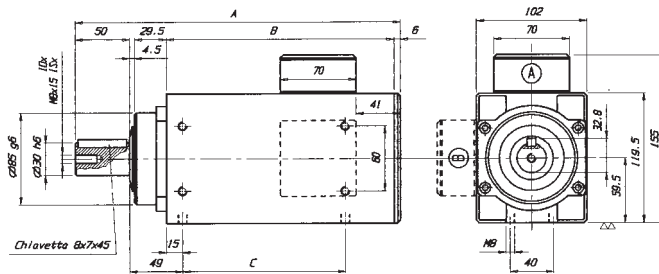

TIPO Type	A	B	C
PE4 10/2	300	210	150
PE4 11/2	340	250	200
PE4 13/2	340	250	200
PE4 14/2	340	250	200

**Sporgenza SC**  
Nose type SC

**NB:** Posizione morsettiere standard come da posizione "A" con forature lato stretto. Su richiesta in posizione "B" con forature lato largo.  
NB: Standard terminal box in "A" position with fixing holes on narrow part. On request terminal box in "B" position with fixing holes on wide part.

# Motori PE4

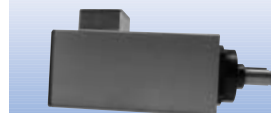
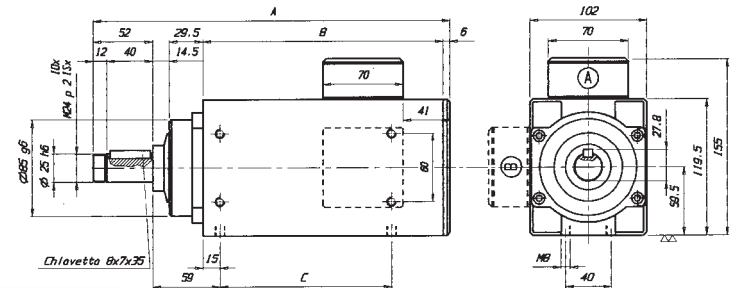

TIPO Type	A	B	C
PE4 10/2	312	210	150
PE4 11/2	352	250	200
PE4 13/2	352	250	200
PE4 14/2	352	250	200

**Sporgenza SF**  
Nose type SF

**NB:** Posizione morsettiere standard come da posizione "A" con forature lato stretto. Su richiesta in posizione "B" con forature lato largo.

NB: Standard terminal box in "A" position with fixing holes on narrow part. On request terminal box in "B" position with fixing holes on wide part.

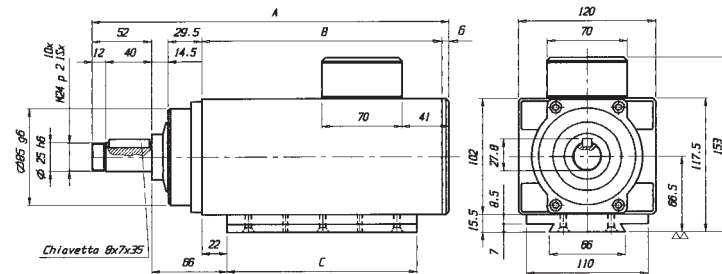

TIPO Type	A	B	C
PE4 10/2	312	210	165
PE4 11/2	352	250	205
PE4 13/2	352	250	205
PE4 14/2	352	250	205

**Sporgenza SFC**  
Nose type SFC



## Motori TM PE4

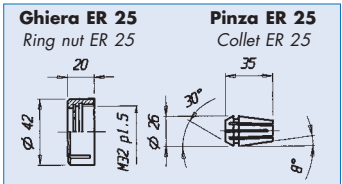
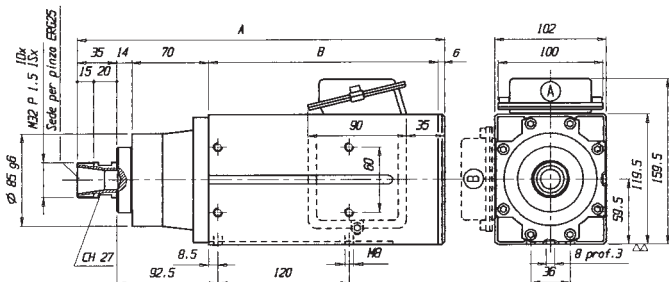

**Ghiera ER 25**  
Ring nut ER 25

**Pinza ER 25**  
Collet ER 25

Diametro Min. 1 Max. 16 mm.  
Diameter Min. 1 Max. 16 mm.

**NB:** Posizione morsettieria standard come da posizione "A" con forature lato stretto. Su richiesta in posizione "B" con forature lato largo.

NB: Standard terminal box in "A" position with fixing holes on narrow part. On request terminal box in "B" position with fixing holes on wide part.



**TIPO**  
Type

	A	B
TM PE4 10/2	335	210
TM PE4 14/2	375	250

**Sporgenza per pinza ER 25**

Nose type for collet ER 25

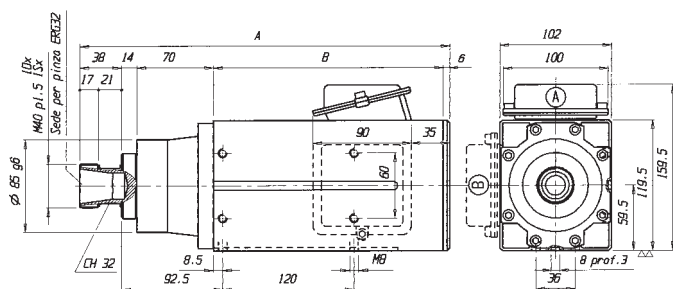

**Ghiera ER 32**  
Ring nut ER 32

**Pinza ER 32**  
Collet ER 32

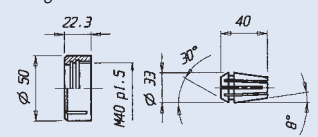

Diametro Min. 1 Max. 20 mm.  
Diameter Min. 1 Max. 20 mm.

**NB:** Pinza e ghiera vengono fornite a richiesta.  
NB: Collet and ring nut only on your request.



## Motori TM PE4

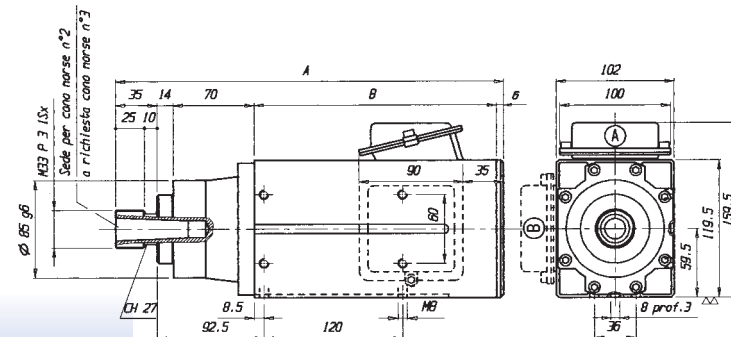

**TIPO**  
Type

	A	B
TMPE4 10/2	335	210
TMPE4 14/2	375	250

**Sporgenza per cono morse 2-3**

Nose type for MK 2-3

**NB:** Posizione morsettieria standard come da posizione "A" con forature lato stretto. Su richiesta in posizione "B" con forature lato largo.

NB: Standard terminal box in "A" position with fixing holes on narrow part. On request terminal box in "B" position with fixing holes on wide part.

**NB:** Pinza e ghiera vengono fornite a richiesta.  
NB: Collet and ring nut only on your request.

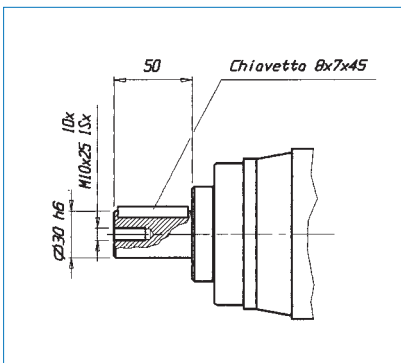

**Versione TM PE4 con sporgenza d'albero SC**  
TM PE4 version with nose type SC

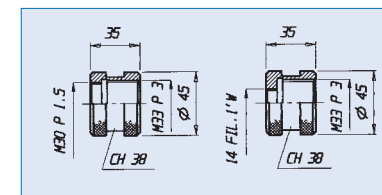

**Ghiera per Cono Morse n° 2-3**  
Ring nuts for MK n° 2-3

## Serie PE5 TM PE5

## Motori PE5

TIPO TYPE	TENSIONE VOLTAGE (VOLT)		FREQU. (HZ)	GIRI (rpm)	POT. RESA OUT. POW. (KW)	ASSORB. ABSORB. (amp)		COS φ	PESO WEIGHT (Kg)
	Standard	a richiesta on request				Standard	a richiesta on request		
PE5 10/2	220/380	220 380	50	3000	1.25	5.60/3.20	5.60 3.20	0.78	12
PE5 10/2	380	220 220/380	100	6000	1.90	4.35	7.55/4.35	0.83	12
PE5 10/2	220	380 220/380	200	12000	3.00	12.3	7.10 12.3/7.10	0.80	12
PE5 10/2	380	220 220/380	300	18000	4.50	10	18 18/10	0.81	12
PE5 14/2	220/380	220 380	50	3000	3.00	11.5/6.60	11.50 6.60	0.82	19.5
PE5 14/2	380	220 220/380	100	6000	3.30	7.40	12.80/7.40	0.82	19.5
PE5 14/2	220	380 220/380	200	12000	4.50	18.2	10.60 18.2/10.60	0.85	19.5
PE5 14/2	380	220 220/380	300	18000	7.00	14.50	25.00 25.0/14.50	0.86	19.5

Per frequenze superiori contattare ns. ufficio tecnico.  
For higher frequencies please contact our technical dept.

TMPE5 10/2	220/380	220 380	50	3000	1.25	5.60/3.20	5.60 3.20	0.78	12
TMPE5 10/2	380	220 220/380	100	6000	1.90	4.35	7.55/4.35	0.83	12
TMPE5 10/2	220	380 220/380	200	12000	3.00	12.3	7.10 12.3/7.10	0.80	12
TMPE5 10/2	380	220 220/380	300	18000	4.50	10	18 18/10	0.81	12
TMPE5 10/2	380	220 220/380	400	24000	4.50	10	18 18/10	0.91	12
TMPE5 14/2	220/380	220 380	50	3000	3.00	11.5/6.60	11.50 6.60	0.82	19.5
TMPE5 14/2	380	220 220/380	100	6000	3.30	7.40	12.80/7.40	0.82	19.5
TMPE5 14/2	220	380 220/380	200	12000	4.50	18.2	10.60 18.2/10.60	0.85	19.5
TMPE5 14/2	380	220 220/380	300	18 000	7.00	14.50	25.00 25.0/14.50	0.86	19.5
TMPE5 14/2	380	220 220/380	400	24000	7.00	14.50	25 25.0/14.50	0.86	19.5

- Per Tensioni 230/400 VOLT l'assorbimento amperometrico va moltiplicato per 0.95.
- For Voltages 230/400 the amps ABS. has to be multiplied by 0.95.

## Motori PE5

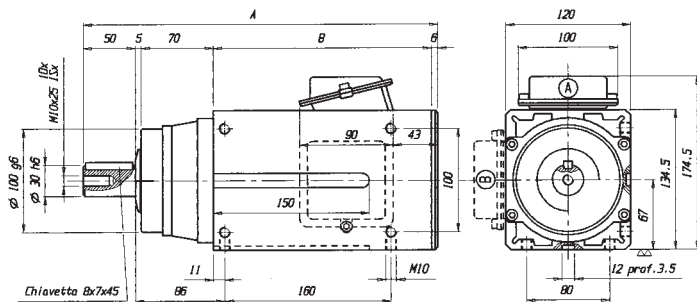

TIPO Type	A	B
PE5 10/2	341	210
PE5 14/2	381	250

**Sporgenza SC**  
Nose type SC

NB: Posizione morsettieria standard come da posizione "A" con forature lato stretto. Su richiesta in posizione "B" con forature lato largo.  
NB: Standard terminal box in "A" position with fixing holes on narrow part. On request terminal box in "B" position with fixing holes on wide part.

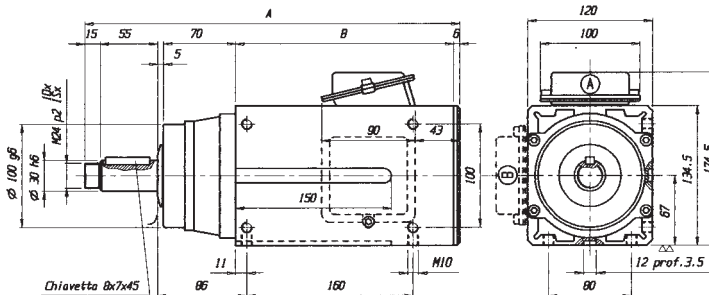

TIPO Type	A	B
PE5 10/2	361	210
PE5 14/2	401	250

**Sporgenza SF**  
Nose type SF

## Motori TM PE5

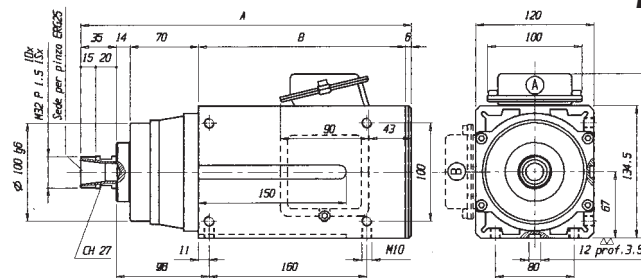

**Ghiera ER 25**  
Ring nut ER 25

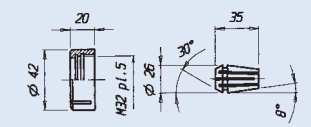

**Pinza ER 25**  
Collet ER 25

**Diametro Min. 1 Max. 16 mm.**  
Diameter Min. 1 Max. 16 mm.

**NB: Pinza e ghiera vengono fornite a richiesta.**  
NB: Collet and ring nut only on your request.



TIPO Type	A	B
TMPE5 10/2	335	210
TMPE5 14/2	375	250

**Sporgenza per pinza ER 25**  
Nose type for collet ER 25





## Motori TM PE5

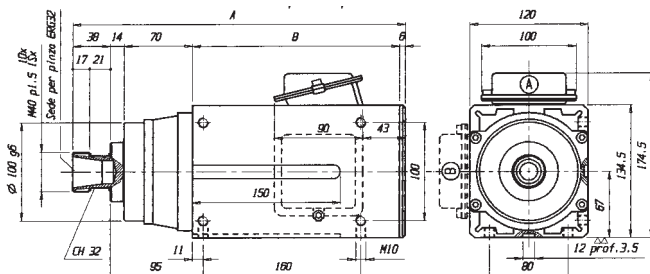

**Ghiera ER 32**  
Ring nut ER 32

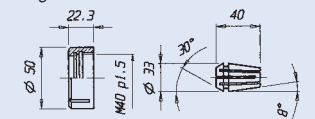

**Pinza ER 32**  
Collet ER 32

**Diametro Min. 1 Max. 20 mm.**  
Diameter Min. 1 Max. 20 mm.

**NB:** Posizione morsettiera standard come da posizione "A" con forature lato stretto. Su richiesta in posizione "B" con forature lato largo.

**NB:** Standard terminal box in "A" position with fixing holes on narrow part. On request terminal box in "B" position with fixing holes on wide part.

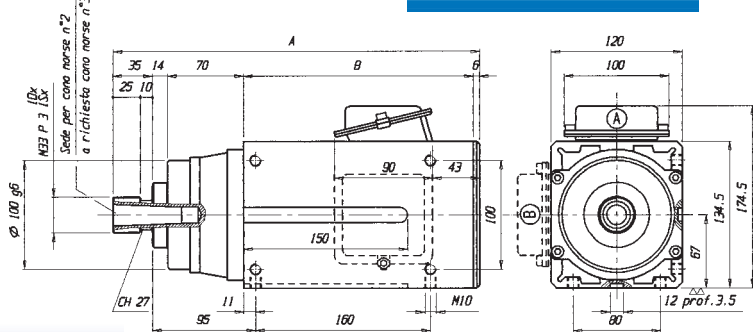

**TIPO**  
Type

	A	B
TMPE5 10/2	338	210
TMPE5 14/2	378	250

**Sporgenza per pinza ER 32**

Nose type for collet ER 32

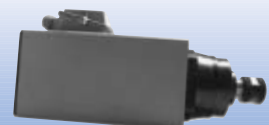

**TIPO**  
Type

	A	B
TMPE5 10/2	335	210
TMPE5 14/2	375	250

**Sporgenza per cono morse 2-3**

Nose type for MK 2-3

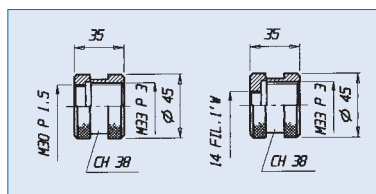

**Ghiera per Cono Morse n° 2-3**  
Collet for MK n° 2-3

**NB:** Pinza e ghiera vengono fornite a richiesta.  
**NB:** Collet and ring nut only on your request.



## Motori TM PE6

TIPO TYPE	TENSIONE VOLTAGE (VOLT)		FREQU. (HZ)	GIRI (rpm)	POT. RESA OUT. POW. (KW)	ASSORB. ABSORB. (amp)		COS $\phi$	PESO WEIGHT (Kg)
	Standard	a richiesta on request				Standard	a richiesta on request		
TMPE6 15/2	220/380	220 380	50	3000	3.40	13.6/7.8	13.6 7.8	0.83	28
TMPE6 15/2	380	220 220/380	100	6000	5.60	11.5	19.9 19.9/11.5	0.84	28
TMPE6 15/2	220	380 220/380	200	12000	8.50	32.7	18.9 32.7/18.9	0.84	28
TMPE6 15/2	380	220 220/380	300	18000	9.50	21.00	36.40 36.40/21.0	0.84	28

- Per Tensioni 230/400 VOLT l'assorbimento amperometrico va moltiplicato per 0.95.
- For Voltages 230/400 the amps ABS. has to be multiplied by 0.95.

## Motori TM PE6

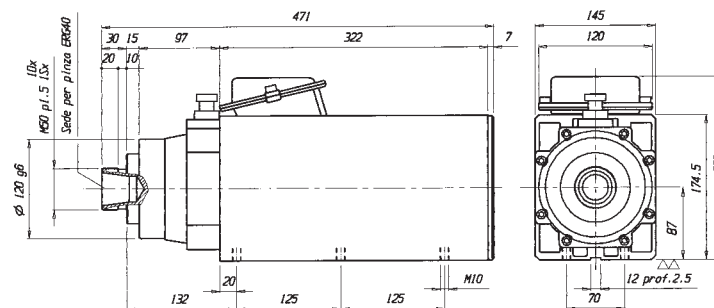

**Pinza ER 40**  
Collet ER 40

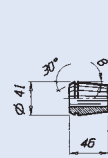

**Ghiera ER 40**  
Ring nut ER 40

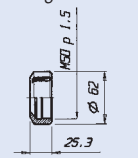

**Diametro Min. 3 Max. 30 mm.**  
Diameter Min. 3 Max. 30 mm.

**NB:** Pinza e ghiera vengono fornite a richiesta.  
**NB:** Collet and ring nut only on your request.



**Sporgenza per pinza ER 40**

Nose type for collet ER 40



## Motori TM PE6

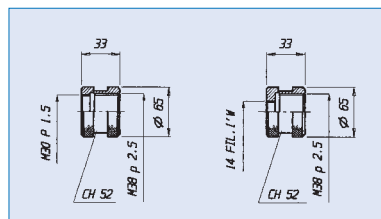
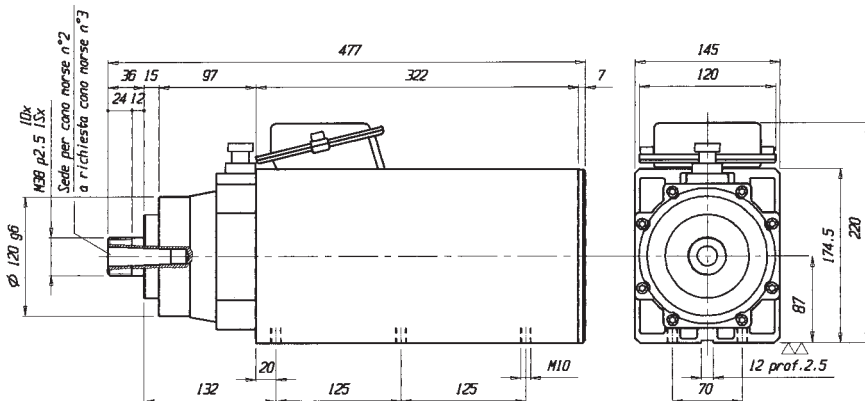

Ghiera per Cono Morse n° 2-3  
Collet for MK n° 2-3

**NB: Pinza e ghiera vengono fornite a richiesta.**  
NB: Collet and ring nut only on your request.

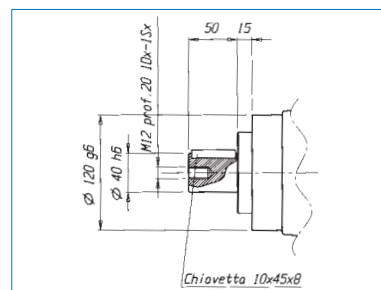

A richiesta sporgenza SC  
Only on request with nose type SC



Sporgenza per cono morse 2-3  
Nose type for MK 2-3



## BIALBERO Double shaft exit

TIPO TYPE	TENSIONE VOLTAGE (VOLT)		FREQU. (HZ)	GIRI (rpm)	POT. RESA OUT. POW. (KW)	ASSORB. ABSORB. (amp)		COS φ	PESO WEIGHT (Kg)		
	Standard	a richiesta on request				Standard	a richiesta on request				
TMPEO 6/2	220	380	220/380	200	12000	0.15	0.80	0.45	0.80/0.45	0.70	2
TMPEO 6/2	380	220	220/380	300	18000	0.16	0.70	1.20	1.20/0.70	0.70	2

• Per Tensioni 230/400 VOLT l'assorbimento amperometrico va moltiplicato per 0.95.  
• For Voltages 230/400 the amps ABS. has to be multiplied by 0.95.

## Motori TM PE0 6/2

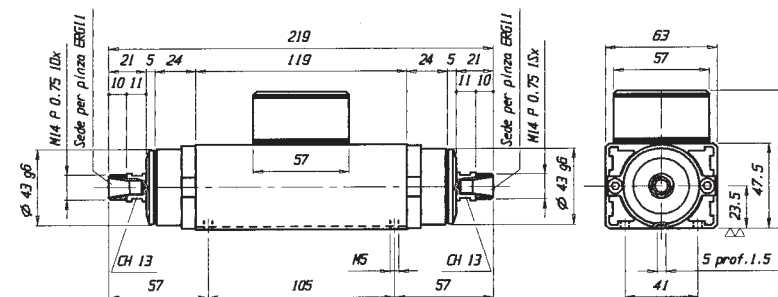

Ghiera ER 11 Ring nut ER 11  
Pinza ER 11 Collet ER 11

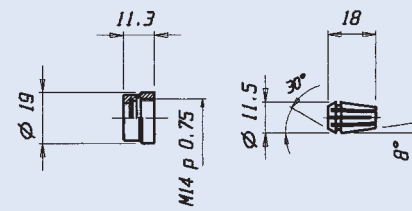

Diametro Min. 1 Max. 7 mm.  
Diameter Min. 1 Max. 7 mm.

**NB: Motore senza ventilazione**  
NB: Engine without ventilation

**NB: Pinza e ghiera vengono fornite a richiesta.**  
NB: Collet and ring nut only on your request.







## BIALBERO Double shaft exit

TIPO TYPE	TENSIONE VOLTAGE (VOLT)			FREQ. (HZ)	GIRI (rpm)	POT. RESA OUT. POW. (KW)	ASSORB. ABSORB. (amp)			COS $\phi$	PESO WEIGHT (Kg)
	Standard	a richiesta on request					Standard	a richiesta on request			
	TMPE2 9/2	220	380				220/380	200	12000		
TMPE2 9/2	380	220	220/380	300	18000	0.30	1.05	1.80	1.80/1.05	0.73	4.5

- Per Tensioni 230/400 VOLT l'assorbimento amperometrico va moltiplicato per 0.95.
- For Voltages 230/400 the amps ABS. has to be multiplied by 0.95.

### Motori TM PE2 9/2

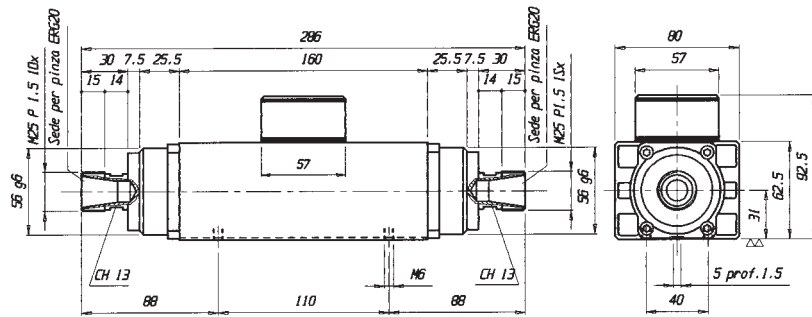

**Ghiera ER 20**  
Ring nut ER 20

**Pinza ER 20**  
Collet ER 20

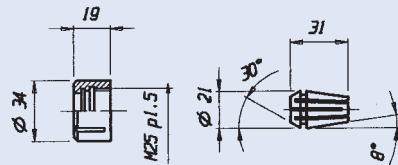

**Diametro Min. 1 Max. 13 mm.**  
Diameter Min. 1 Max. 13 mm.

**NB: Motore senza ventilazione**  
NB: Engine without ventilation

**NB: Pinza e ghiera vengono fornite a richiesta.**  
NB: Collet and ring nut only on your request.



## BIALBERO Double shaft exit

TIPO TYPE	TENSIONE VOLTAGE (VOLT)			FREQ. (HZ)	GIRI (rpm)	POT. RESA OUT. POW. (KW)	ASSORB. ABSORB. (amp)			COS $\phi$	PESO WEIGHT (Kg)
	Standard	a richiesta on request					Standard	a richiesta on request			
	TMPE3 9/2	220/380	220				380	50	3000		
TMPE3 9/2	380	220	220/380	100	6000	0.45	1.40	2.40	2.40/1.40	0.75	7.5
TMPE3 9/2	220	380	220/380	200	12000	0.75	4.00	2.30	4.00/2.30	0.75	7.5
TMPE3 9/2	380	220	220/380	300	18000	1.00	3.20	5.50	5.50/3.20	0.75	7.5
TMPE3 12/2	220/380	220	380	50	3000	0.30	1.70/1.00	1.70	1.00	0.70	9
TMPE3 12/2	380	220	220/380	100	6000	0.75	1.90	3.30	3.30/1.90	0.75	9
TMPE3 12/2	220	380	220/380	200	12000	1.50	6.30	3.60	6.30/3.60	0.80	9
TMPE3 12/2	380	220	220/380	300	18000	2.00	5.20	9.00	9.00/5.20	0.80	9

- Per Tensioni 230/400 VOLT l'assorbimento amperometrico va moltiplicato per 0.95.
- For Voltages 230/400 the amps ABS. has to be multiplied by 0.95.

### Motori TM PE3

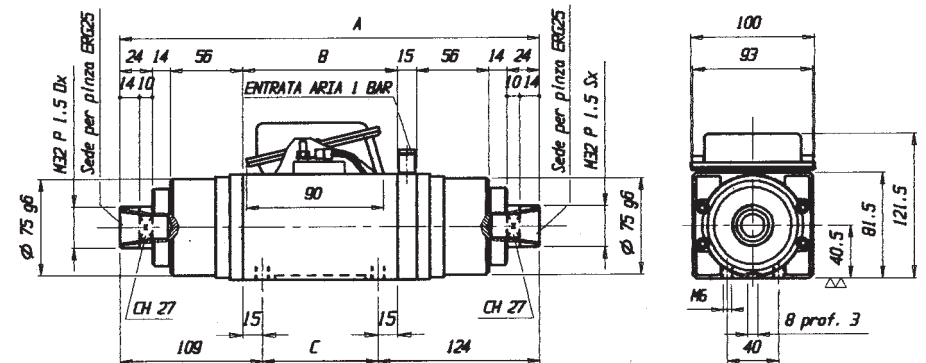

**Ghiera ER 25**  
Ring nut ER 25

**Pinza ER 25**  
Collet ER 25

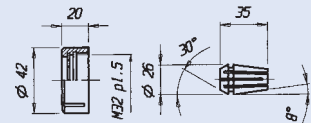

**Diametro Min. 1 Max. 16 mm.**  
Diameter Min. 1 Max. 16 mm.

**NB: Raffreddamento ad aria compressa**  
NB: Compressed air cooling

**NB: Pinza e ghiera vengono fornite a richiesta.**  
NB: Collet and ring nut only on your request.



TIPO Type	A	B	C
TMPE3 9/2	323	120	90
TMPE3 12/2	353	150	120



## BIALBERO Double shaft exit

TIPO TYPE	TENSIONE VOLTAGE (VOLT)		FREQU. (HZ)	GIRI (rpm)	POT. RESA OUT. POW. (KW)	ASSORB. ABSORB. (amp)		COS φ	PESO WEIGHT (Kg)
	Standard	a richiesta on request				Standard	a richiesta on request		
	TMPE4 10/2	220/380				220 380	50		
TMPE4 10/2	380	220 220/380	100	6000	1.10	2.80	4.90/2.80	0.77	14.5
TMPE4 10/2	220	380 220/380	200	12000	2.20	9.70	5.60/9.70/5.60	0.77	14.5
TMPE4 10/2	380	220 220/380	300	18000	3.30	7.90	13.70/7.90	0.80	14.5
TMPE4 14/2	220/380	220 380	50	3000	1.10	5.50/3.15	5.50 3.15	0.72	16
TMPE4 14/2	380	220 220/380	100	6000	2.20	5.50	9.50/5.50	0.77	16
TMPE4 14/2	220	380 220/380	200	12000	3.70	15.00	8.70/15.00/8.70	0.78	16
TMPE4 14/2	380	220 220/380	300	18000	5.60	11.5	20.00/11.5	0.85	16

- Per Tensioni 230/400 VOLT l'assorbimento amperometrico va moltiplicato per 0.95.
- For Voltages 230/400 the amps ABS. has to be multiplied by 0.95.

### Motori TM PE4

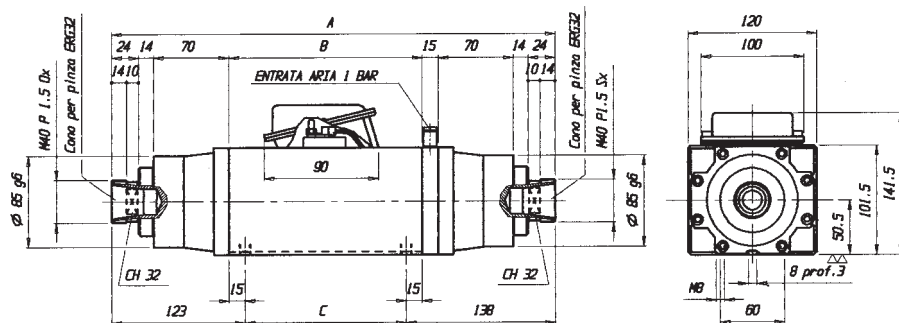

**Ghiera ER 32**  
Ring nut ER 32

**Pinza ER 32**  
Collet ER 32

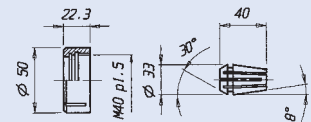

**Diametro Min. 1 Max. 20 mm.**  
Diameter Min. 1 Max. 20 mm.

**NB: Raffreddamento ad aria compressa**  
NB: Compressed air cooling

**NB: Pinza e ghiera vengono fornite a richiesta.**  
NB: Collet and ring nut only on your request.



## BIALBERO Double shaft exit

TIPO TYPE	TENSIONE VOLTAGE (VOLT)		FREQU. (HZ)	GIRI (rpm)	POT. RESA OUT. POW. (KW)	ASSORB. ABSORB. (amp)		COS φ	PESO WEIGHT (Kg)
	Standard	a richiesta on request				Standard	a richiesta on request		
	TMPE5 10/2	220/380				220 380	50		
TMPE5 10/2	380	220 220/380	100	6000	1.90	4.40	7.55/4.40	0.83	17.5
TMPE5 10/2	220	380 220/380	200	12000	3.00	12.30	7.10/12.30/7.10	0.80	17.5
TMPE5 10/2	380	220 220/380	300	18000	4.50	10.5	18.00/10.5	0.81	17.5
TMPE5 14/2	220/380	220 380	50	3000	3.00	11.5/6.60	11.5 6.60	0.82	20.5
TMPE5 14/2	380	220 220/380	100	6000	3.30	7.40	12.80/7.40	0.82	20.5
TMPE5 14/2	220	380 220/380	200	12000	4.50	18.20	10.6/18.20/10.6	0.85	20.5
TMPE5 14/2	380	220 220/380	300	18000	7.00	14.50	25.00/14.50	0.86	20.5

- Per Tensioni 230/400 VOLT l'assorbimento amperometrico va moltiplicato per 0.95.
- For Voltages 230/400 the amps ABS. has to be multiplied by 0.95.

### Motori TM PE5

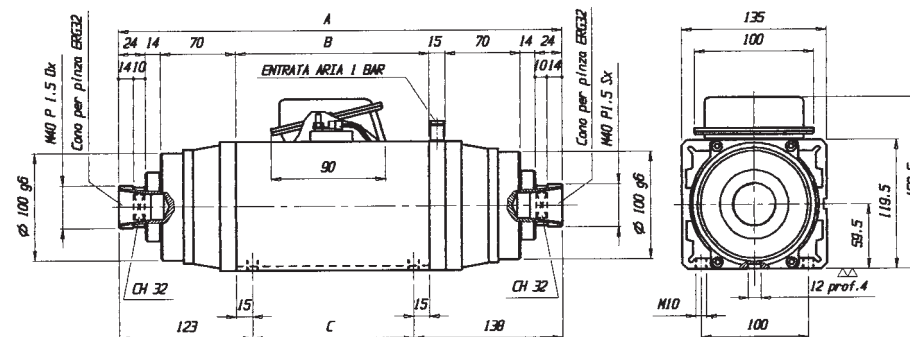

**Ghiera ER 32**  
Ring nut ER 32

**Pinza ER 32**  
Collet ER 32

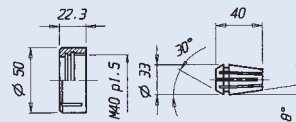

**Diametro Min. 1 Max. 20 mm.**  
Diameter Min. 1 Max. 20 mm.

**NB: Raffreddamento ad aria compressa**  
NB: Compressed air cooling

**NB: Pinza e ghiera vengono fornite a richiesta.**  
NB: Collet and ring nut only on your request.



TIPO Type	A	B	C
TMPE4 10/2	371	140	110
TMPE4 14/2	411	180	150



TIPO Type	A	B	C
TMPE5 10/2	371	140	110
TMPE5 14/2	411	180	150



## Serie SQUADRATICI Squaring machines

TIPO TYPE	TENSIONE VOLTAGE (VOLT)	FREQU. (HZ)	GIRI (rpm)	POT. RESA OUT. POW. (KW)	ASSORB. ABSORB. (amp)	COS $\phi$	PESO WEIGHT (Kg)
PE5 10/2	220/380 (380Δ)	50/100	3000/6000	1.25/1.90	5.60/3.20 (4.35Δ)	0.78	10
PE5 14/2	220/380 (380Δ)	50/100	3000/6000	3.00/3.30	11.5/6.6 (7.40Δ)	0.82	17

### Solo a richiesta tensioni 230/400

Only on request voltages 230/400

- Per Tensioni 230/400 VOLT l'assorbimento amperometrico va moltiplicato per 0.95.
- For Voltages 230/400 the amps ABS. has to be multiplied by 0.95.

## Motori PE5

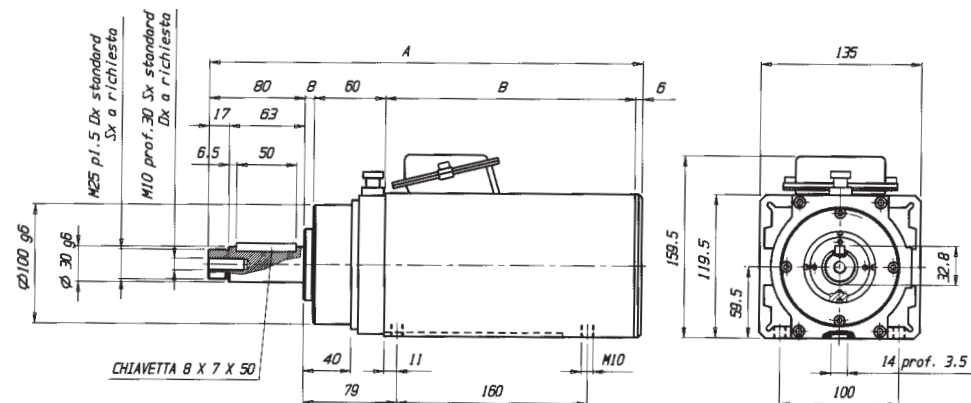

## Serie SQUADRATICI Squaring machines

TIPO TYPE	TENSIONE VOLTAGE (VOLT)	FREQU. (HZ)	GIRI (rpm)	POT. RESA OUT. POW. (KW)	ASSORB. ABSORB. (amp)	COS $\phi$	PESO WEIGHT (Kg)
PE6 11/2	220/380 (380Δ)	50/100	3000/6000	2.3/4.0	9.5/5.5 (9.1Δ)	0.82	22
PE6 15/2	220/380 (380Δ)	50/100	3000/6000	3.4/5.6	3.50/2 (11.5Δ)	0.83	30

### Solo a richiesta tensioni 230/400

Only on request voltages 230/400

- Per Tensioni 230/400 VOLT l'assorbimento amperometrico va moltiplicato per 0.95.
- For Voltages 230/400 the amps ABS. has to be multiplied by 0.95.

## Motori PE6

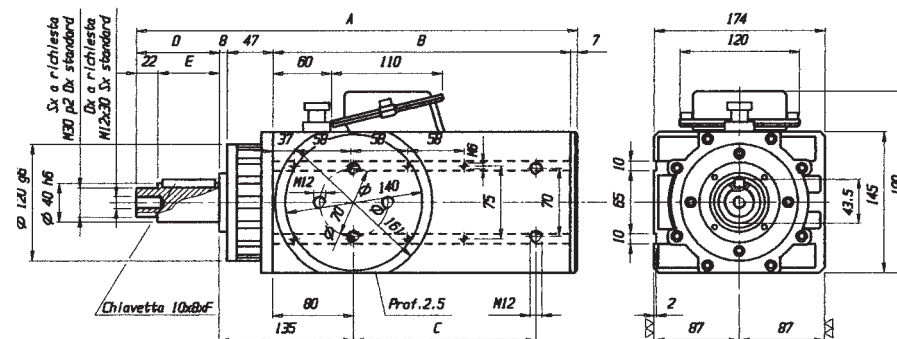

TIPO Type	A	B
PE5 10/2	364	210
PE5 14/2	404	250

Solo su richiesta/Only on request

Albero/Shaft  $\varnothing$  40



TIPO Type	A	B	C	D	E	F
PE6 11/2	452	305	170	85	63	50
PE6 11/2	482	305	170	115	93	80
PE6 11/2	507	305	170	140	118	100
PE6 15/2	495	348	230	85	63	50
PE6 15/2	525	348	230	115	93	80
PE6 15/2	550	348	230	140	118	100





## Serie SQUADRATICI Squaring machines

TIPO TYPE	TENSIONE VOLTAGE (VOLT)	FREQU. (HZ)	GIRI (rpm)	POT. RESA OUT. POW. (KW)	ASSORB. ABSORB. (amp)	COS $\phi$	PESO WEIGHT (Kg)
TMPE6 13/2	220/380 (380Δ)	50/100	3000/6000	2.90/4.8	11.45/6.60 (10.90Δ)	0.82	28
TMPE6 15/2	220/380 (380Δ)	50/100	3000/6000	3.40/5.60	13.6/7.8 (11.5Δ)	0.83	32
TMPE6 17/2	220/380 (380Δ)	50/100	3000/6000	3.80/6.65	14.90/8.60 (14.90Δ)	0.83	36

### Solo a richiesta tensioni 230/400

Only on request voltages 230/400

- Per Tensioni 230/400 VOLT l'assorbimento amperometrico va moltiplicato per 0.95.
- For Voltages 230/400 the amps ABS. has to be multiplied by 0.95.

## Motori TMPE6

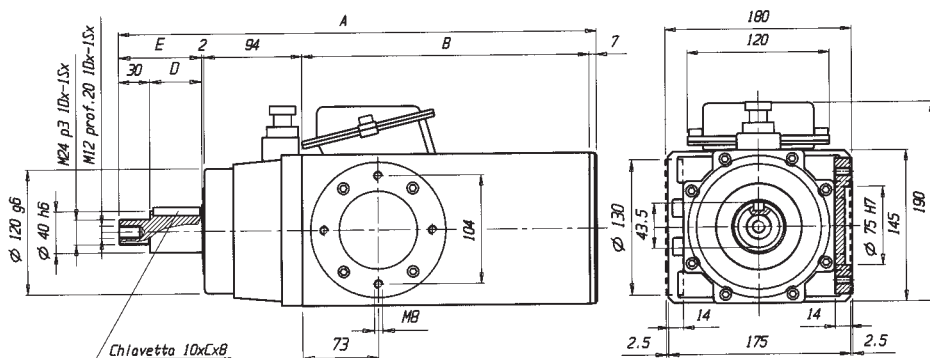

## Serie SQUADRATICI Squaring machines

TIPO TYPE	TENSIONE VOLTAGE (VOLT)	FREQU. (HZ)	GIRI (rpm)	POT. RESA OUT. POW. (KW)	ASSORB. ABSORB. (amp)	COS $\phi$	PESO WEIGHT (Kg)
TMPE8 10/2	220/380 (380Δ)	50/100	3000/6000	8.2/11.2	29.3/16.9 (25.5Δ)	0.87	60
TMPE8 13/2	220/380 (380Δ)	50/100	3000/6000	11.2/16.4	37.3/21.5 (32.6Δ)	0.90	63

### Solo a richiesta tensioni 230/400

Only on request voltages 230/400

- Per Tensioni 230/400 VOLT l'assorbimento amperometrico va moltiplicato per 0.95.
- For Voltages 230/400 the amps ABS. has to be multiplied by 0.95.

## Motori TMPE8

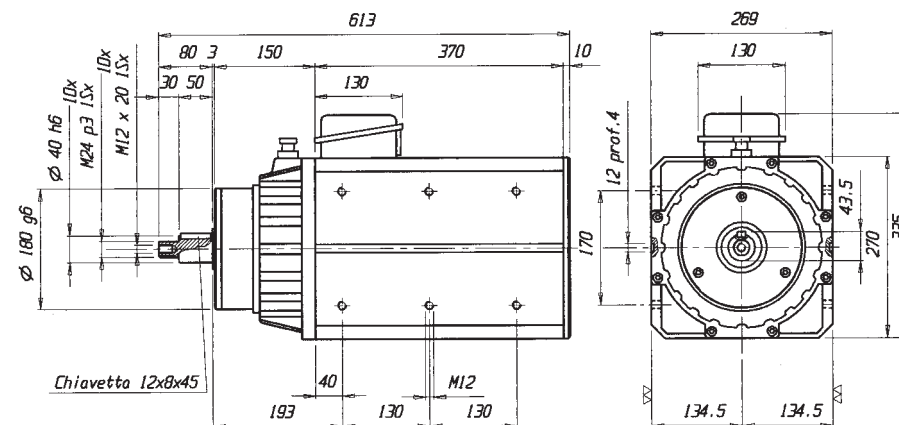

TIPO Type	A	B	C	D	E
TMPE6 13/2	459	276	45	50	80
TMPE6 13/2	499	276	80	90	120
TMPE6 15/2	505	322	45	50	80
TMPE6 15/2	545	322	80	90	120
TMPE6 17/2	555	372	45	50	80
TMPE6 17/2	595	372	80	90	120

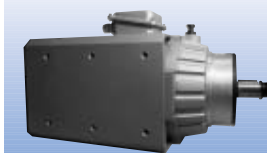



## Motori Serie S



## Motori S1

TIPO TYPE	TENSIONE VOLTAGE (VOLT)	FREQU. (HZ)	GIRI (rpm)	POT. RESA OUT. POW. (KW)	ASSORB. ABSORB. (amp)	COS $\phi$	PESO WEIGHT (Kg)
S1 12/2	220/380	50	3000	2.90	11.5/6.6	0.83	25
	380Δ	100	6000	4.80	10.90	0.83	
S1 14/2	220/380	50	3000	4.00	15.5/8.90	0.83	27
	380Δ	100	6000	6.65	14.9	0.84	
S1 13/4	220/380	50	1500	2.20	9.3/5.3	0.80	25
	380Δ	100	3000	3.60	8.2	0.82	
S1 17/4	220/380	50	1500	3.00	11.8/6.80	0.80	27
	380Δ	100	3000	4.50	10.2	0.82	
S2 12/2	220/380	50	3000	5.20	20.0/11.4	0.82	45
	380Δ	100	6000	7.30	16.2	0.83	
S2 15/2	220/380	50	3000	7.00	27.0/15.6	0.82	60
	380Δ	100	6000	9.20	20.0	0.83	
S2 12/4	220/380	50	1500	3.70	14.9/8.6	0.80	45
	380Δ	100	3000	5.40	12.0	0.82	
S2 14/4	220/380	50	1500	4.50	17.7/10.2	0.80	60
	380Δ	100	3000	6.35	14.0	0.82	
S3 9/2	220/380	50	3000	5.50	20.1/11.6	0.86	55
	380Δ	100	6000	8.50	17.8	0.86	
S3 12/2	220/380	50	3000	7.10	26.0/15.0	0.87	57
	380Δ	100	6000	11.3	23.5	0.87	
S3 14/2	220/380	50	3000	8.80	32.5/18.8	0.87	60
	380Δ	100	6000	12.6	26.5	0.87	
S3 16/2	220/380	50	3000	10.5	39.0/22.5	0.87	62
	380Δ	100	6000	14.3	30	0.87	
S3 20/2	220/380	50	3000	14.2	53.7/31.0	0.87	65
	380Δ	100	6000	19.0	40	0.87	
S3 12/4	220/380	50	1500	5.20	20.8/12.0	0.83	57
	380Δ	100	3000	6.30	14	0.83	
S3 16/4	220/380	50	1500	7.10	27.7/16.0	0.83	60
	380Δ	100	3000	8.40	18.5	0.84	
S3 18/4	220/380	50	1500	8.50	34.6/20	0.83	62
	380Δ	100	3000	10.2	23	0.84	
S3 20/4	220/380	50	1500	10.5	41.6/24.0	0.83	65
	380Δ	100	3000	12.2	26.9	0.84	

- Per Tensioni 230/400 VOLT l'assorbimento amperometrico va moltiplicato per 0.95.
- For Voltages 230/400 the amps ABS. has to be multiplied by 0.95.

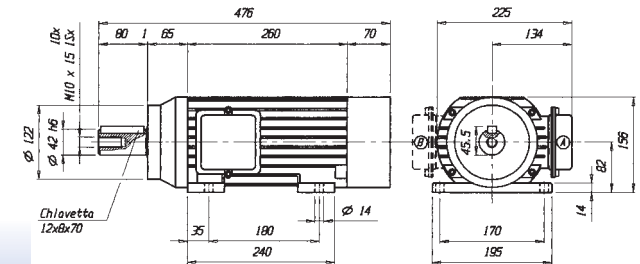

Sporgenza SC  
Nose type SC

**NB:** Posizione morsetteria standard come da posizione "A" con forature lato destro. Su richiesta in posizione "B" con forature lato sinistro.

**NB:** Standard terminal box in "A" position with fixing holes on right side. On request terminal box in "B" position with fixing holes on left side.

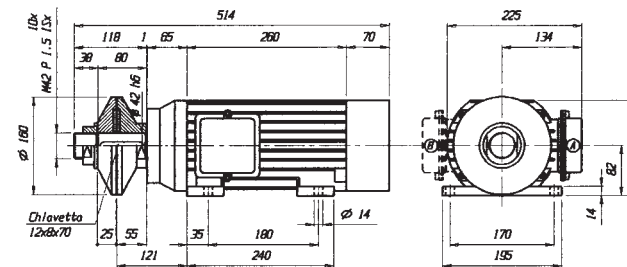

Sporgenza SCF  
e Flange  
Nose type SCF with flanges





## Motori S2

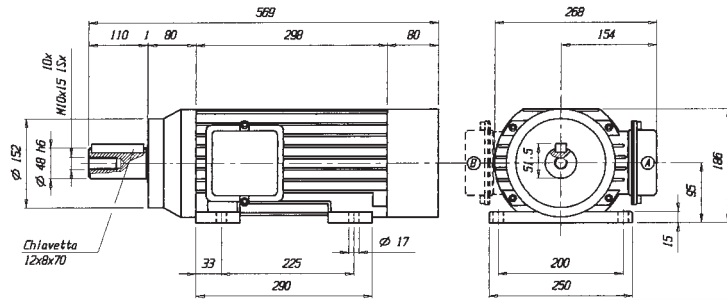

**Sporgenza SC**  
Nose type SC

**NB:** Posizione morsettieria standard come da posizione "A" con forature lato destro. Su richiesta in posizione "B" con forature lato sinistro.

*NB: Standard terminal box in "A" position with fixing holes on right side. On request terminal box in "B" position with fixing holes on left side.*



## Motori S3

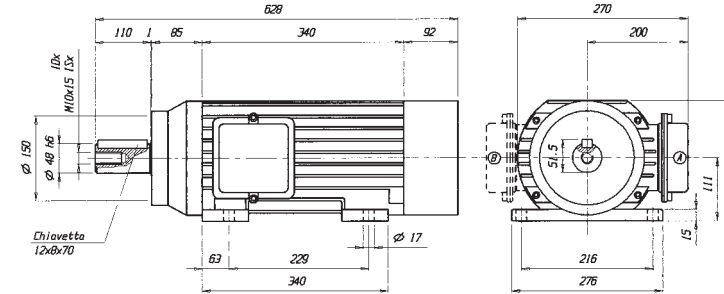

**Sporgenza SC**  
Nose type SC

**NB:** Posizione morsettieria standard come da posizione "A" con forature lato destro. Su richiesta in posizione "B" con forature lato sinistro.

*NB: Standard terminal box in "A" position with fixing holes on right side. On request terminal box in "B" position with fixing holes on left side.*

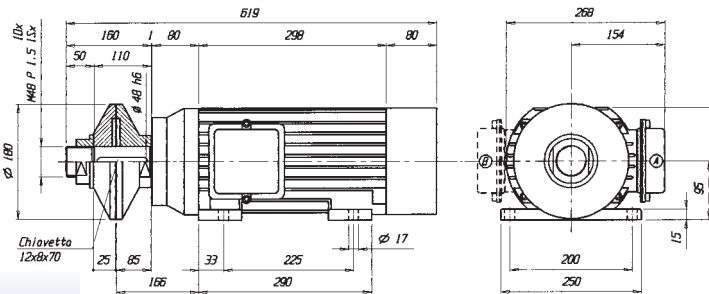

**Sporgenza SCF**  
e Flange  
Nose type SCF with flanges

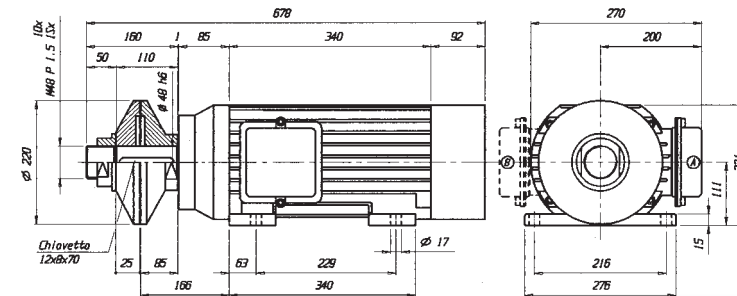

**Sporgenza SCF**  
e Flange  
Nose type SCF with flanges

## Bilanciatura

### Balance

- **Bilanciatura Standard con 1/2 chiavetta per utensile ad una cava**

*Standard balance with half key for one slot tool.*

- **A richiesta bilanciatura con chiavetta intera per utensile a due cave**

*On request balance with full key for two slot tool.*

- **Si raccomanda l'uso di utensili bilanciati**

*We strictly recommend the use of balanced tools.*

- **Tutti i motori vengono forniti privi di pressacavo**

*All motors are supplied without the plastic gland.*

- **È importante in sede d'ordine specificare il tipo di motore completo di Tensione, Frequenza, Potenza.**

*When ordering please specify the Voltage, Frequency and Power of the motor.*

- **In tutti i motori sono montati cuscinetti per alte velocità ingrassati a vita.**

*All motors have bearings for high speeds and do not require any additional lubrication.*

- **Tutti i motori sono a normativa europea (marchio CE).**

*All motors conform to the European CE standard.*

- **Direttiva macchine (89/392/CEE).**

*All motors conform to the "machines" directive (89/392/CEE).*

- **Direttiva compatibilità elettromagnetica EMC (89/336/CEE).**

*All motors conform to the electromagnetic compatibility directive EMC (89/336/CEE).*

- **Direttiva bassa tensione (73/23/CEE).**

*All motors conform to the "low voltage directive" 73/23/CEE.*

- **Tutti i motori (a specifica richiesta) possono essere documentati con bollettini di collaudo funzionale, in fase di certificazione finale.**

*(On request) all motors can be supplied with a functional test certificate, during the final phase of certification.*

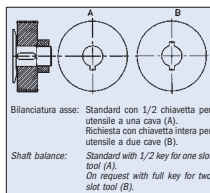

## Serie Elettromandrini TMA

### cambio utensile automatico

### automatic tool change

TIPO TYPE	TENSIONE VOLTAGE (VOLT)	FREQU. (HZ)	GIRI (rpm)	POT. RESA OUT. POW. (KW)	ASSORB. ABSORB. (amp)	COS φ	PESO WEIGHT (Kg)
TMA 4 10/2	350	400/500	24000/30000	3.6	8.6	0.82	16
ISO 20							

**Solo a richiesta tensioni 230 o 400**

*Only on request voltages 230 or 400*

- Per Tensioni 230 o 400 VOLT l'assorbimento amperometrico va moltiplicato per 0.95.
- For Voltages 230 or 400 the amps ABS. has to be multiplied by 0.95.

## Elettromandrini TMA4 ISO 20

**Raffreddato ad aria compressa**

*Compressed air cooling*

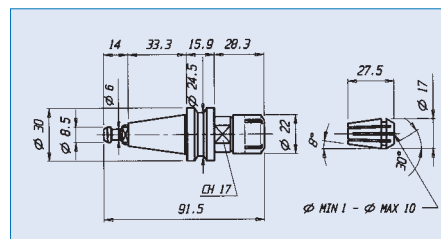
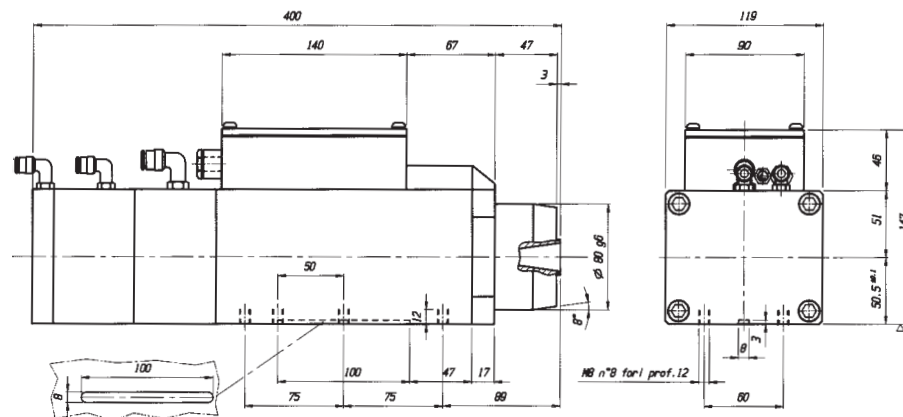

**Cono ISO 20 con attacco per pinza ER 16 e ghiera ER 16 mini**  
*ISO 20 taper for collet ER 16 and ring nut ER 16 mini*

**NB: La versione a 24000 giri richiede l'utilizzo di cuscinetti ceramici.**  
*Important: ceramic ball-bearings required for 24000 rpm.*

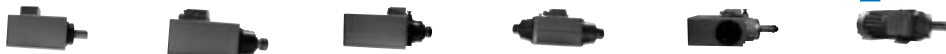





## Serie Elettromandrini TMA

### cambio utensile automatico

### automatic tool change

TIPO TYPE	TENSIONE VOLTAGE (VOLT)	FREQU. (HZ)	GIRI (rpm)	POT. RESA OUT. POW. (KW)	ASSORB. ABSORB. (amp)	COS $\phi$	PESO WEIGHT (Kg)
TMA 4 10/2	350	200/300	12000/18000	3.6	8.6	0.82	16
TMA 4 10/2	350	200/400	12000/24000	3.6	8.6	0.82	16

Solo a richiesta tensioni 230 o 400

Only on request voltages 230 or 400

- Per Tensioni 230 o 400 VOLT l'assorbimento amperometrico va moltiplicato per 0.95.
- For Voltages 230 or 400 the amps ABS. has to be multiplied by 0.95.

## Elettromandrini TMA4 ISO 30

Raffreddato ad aria compressa

Compressed air cooling

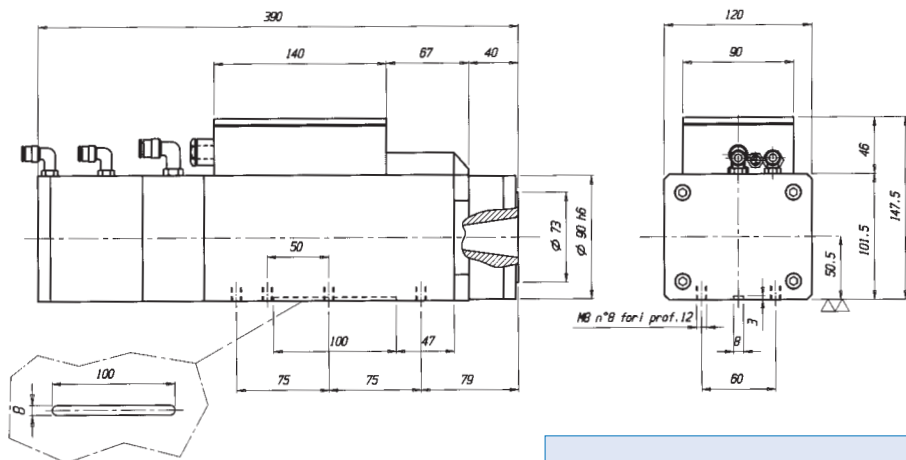

Diametro Min. 1  
Max 20 mm.  
Diameter Min. 1  
Max 20 mm.

Cono ISO 30 con attacco per pinza ER 32  
ISO 30 taper for collet ER 32

NB: La versione a 24000 giri richiede l'utilizzo di cuscinetti ceramici.  
Important: ceramic ball-bearings required for 24000 rpm.



## Serie Elettromandrini TMA

### cambio utensile automatico

### automatic tool change

TIPO TYPE	TENSIONE VOLTAGE (VOLT)	FREQU. (HZ)	GIRI (rpm)	POT. RESA OUT. POW. (KW)	ASSORB. ABSORB. (amp)	COS $\phi$	PESO WEIGHT (Kg)
TMA 5 14/2	350	200/300	12000/18000	7	16	0.85	25
TMA 5 14/2	350	200/400	12000/24000	7	16	0.82	25

Solo a richiesta tensioni 230 o 400

Only on request voltages 230 or 400

- Per Tensioni 230 o 400 VOLT l'assorbimento amperometrico va moltiplicato per 0.95.
- For Voltages 230 or 400 the amps ABS. has to be multiplied by 0.95.

## Elettromandrini TMA5 ISO 30

Raffreddato ad aria compressa

Compressed air cooling

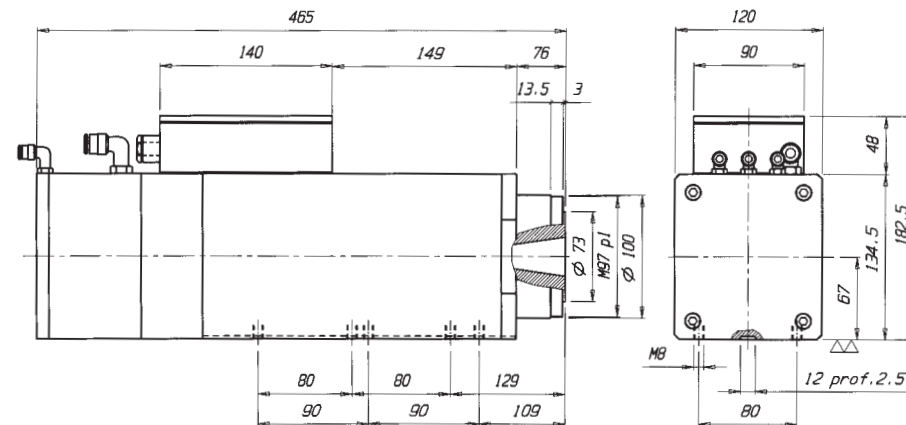

Diametro Min. 1  
Max 20 mm.  
Diameter Min. 1  
Max 20 mm.

Cono ISO 30 con attacco per pinza ER 32  
ISO 30 taper for collet ER 32

NB: La versione a 24000 giri richiede l'utilizzo di cuscinetti ceramici.  
Important: ceramic ball-bearings required for 24000 rpm.





## Serie Elettromandri TMA

### cambio utensile automatico

### automatic tool change

TIPO TYPE	TENSIONE VOLTAGE (VOLT)	FREQU. (HZ)	GIRI (rpm)	POT. RESA OUT. POW. (KW)	ASSORB. ABSORB. (amp)	COS φ	PESO WEIGHT (Kg)
<b>TMA 6 17/2</b>	350	200/300	12000/18000	11	26	0.85	42

**Solo a richiesta tensioni 230 o 400**

*Only on request voltages 230 or 400*

- Per Tensioni 230 o 400 VOLT l'assorbimento amperometrico va moltiplicato per 0.95.
- For Voltages 230 or 400 the amps ABS. has to be multiplied by 0.95.

## Elettromandri TMA6 ISO 40

**Raffreddato ad aria compressa**

*Compressed air cooling*

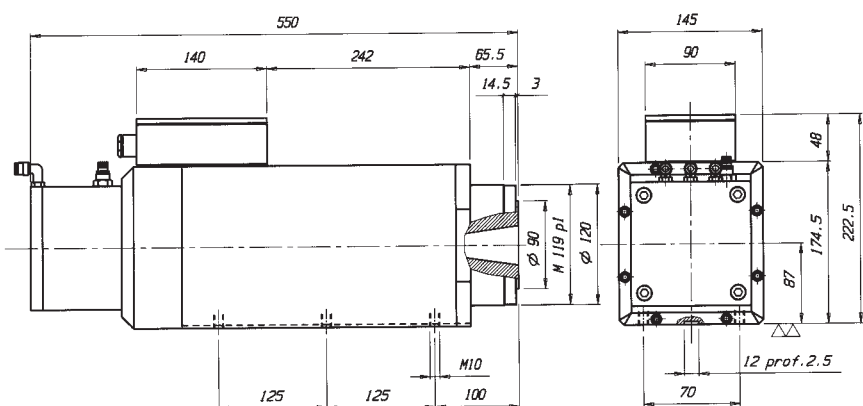

**Diametro Min. 3  
Max 30 mm.**  
Diameter Min. 3  
Max 30 mm.

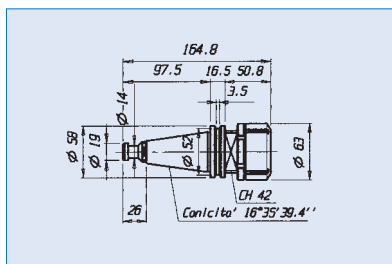

**Cono ISO 40 con attacco per pinza ER 40**  
*Iso 40 taper for collet ER 40*



## Serie Elettromandri TMA

### cambio utensile automatico

### automatic tool change

TIPO TYPE	TENSIONE VOLTAGE (VOLT)	FREQU. (HZ)	GIRI (rpm)	POT. RESA OUT. POW. (KW)	ASSORB. ABSORB. (amp)	COS φ	PESO WEIGHT (Kg)
<b>TMA 6 12/4</b>	350	400/600	18000	8.8	21.6	0.80	38
<b>TMA 6 17/4</b>	350	400/600	18000	12	28.5	0.82	43

**Solo a richiesta tensioni 230 o 400**

*Only on request voltages 230 or 400*

- Per Tensioni 230 o 400 VOLT l'assorbimento amperometrico va moltiplicato per 0.95.
- For Voltages 230 or 400 the amps ABS. has to be multiplied by 0.95.

## Elettromandri TMA6 HSK F63

**Raffreddato mezzo elettroventola**

*Cooled by electric fan*

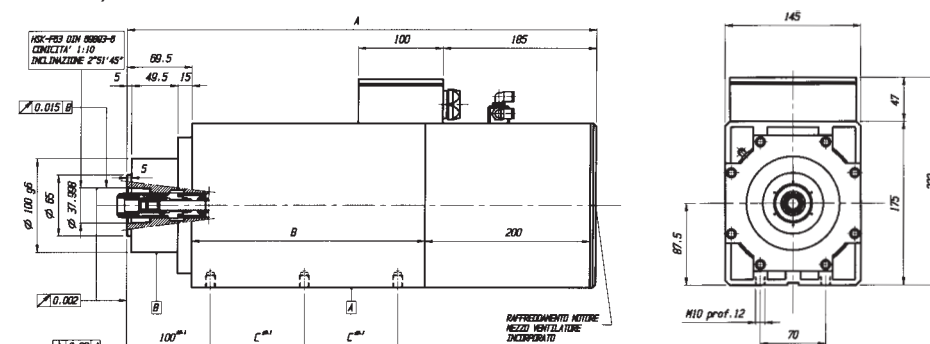

PRESSACAVI PER ALIMENTAZIONE MOTORE

CONNETTORE A BASSA TENSIONE V. 24 VCC PER CONTROLLO SICUREZZA

ENTRATA ARIA PER PRESSURIZZAZIONE COPPIA ANTERIORE 3 Bar

CORSA PISTONE AVANTI

ENTRATA ARIA PER PULIZIA CONO

CORSA PISTONE INDIETRO

CONO HSK F63 DIN69893

**Cono porta utensile HSK F63 Din. 69893**  
*Tool holder taper HSK F636 Din. 69893*



TIPO Type	A	B	C
12/4	523	248.5	100
17/4	573	298.5	125

## Serie AF Raffreddato a liquido Liquid Cooled

TIPO TYPE	TENSIONE VOLTAGE (VOLT)	FREQU. (HZ)	GIRI (rpm)	POT. RESA OUT. POW. (KW)	ASSORB. ABSORB. (amp)	COS $\phi$	PESO WEIGHT (Kg)
AF60 2.5/2	220	400	24000	0.25	1.8	0.70	2
AF60 2.5/2	380	400	24000	0.25	1.0	0.70	2
AF60 2.5/2	220	670	40000	0.25	1.8	0.70	2
AF60 2.5/2	380	670	40000	0.25	1	0.70	2
AF60 6/2	220	400	24000	0.55	2.6	0.75	2.5
AF60 6/2	380	400	24000	0.55	1.5	0.75	2.5
AF60 6/2	220	670	40000	0.55	2.6	0.75	2.5
AF60 6/2	380	670	40000	0.55	1.5	0.75	2.5

### Elettromandrini AF60 2.5-6/2

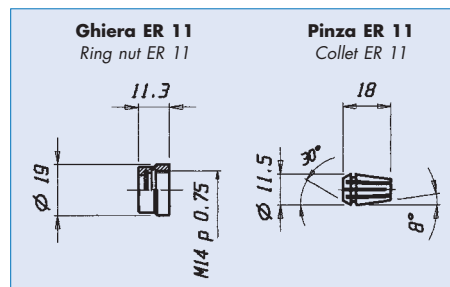
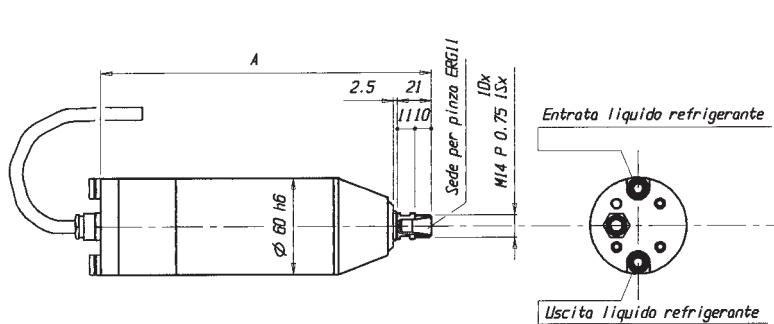

Diametro Min. 1 Max. 7 mm.  
Diameter Min. 1 Max. 7 mm.

NB: Pinza e ghiera vengono fornite a richiesta.  
NB: Collet and ring nut only on your request.



TIPO Type	A
AF60 2.5/2	167.5
AF60 6/2	202.5

## Serie AF Raffreddato a liquido Liquid Cooled

TIPO TYPE	TENSIONE VOLTAGE (VOLT)	FREQU. AL GINOCCHIO (HZ)	FREQU. (HZ)	GIRI (rpm)	POT. RESA OUT. POW. (KW)	ASSORB. ABSORB. (amp)	COS $\phi$	PESO WEIGHT (Kg)
AF80 9/2	220	300	400	24000	1.1	5.2	0.75	6.5
AF80 9/2	380	300	400	24000	1.1	3.0	0.75	6.5
AF80 9/2	220	400	670	40000	1.4	5.8	0.75	6.5
AF80 9/2	380	400	670	40000	1.4	3.3	0.75	6.5

### Elettromandrini AF80 9/2

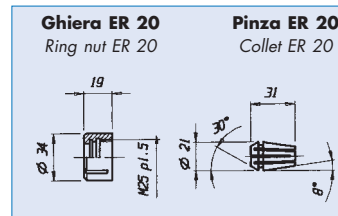
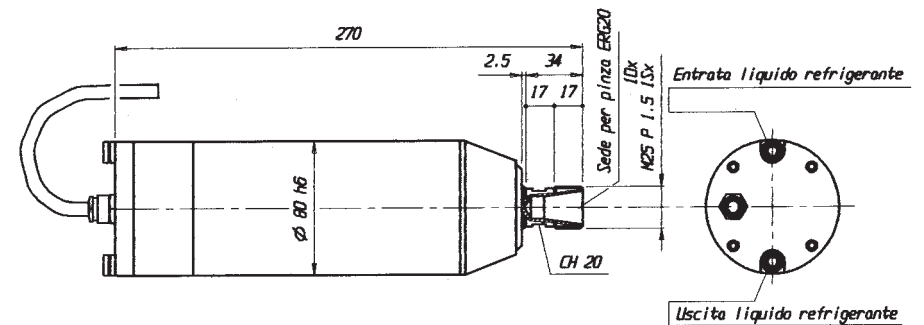

Diametro Min. 1 Max 13 mm.  
Diameter Min. 1 Max 13 mm.

NB: Pinza e ghiera vengono fornite a richiesta.  
NB: Collet and ring nut only on your request.



# AF80

## Serie AF Raffreddato a liquido Liquid Cooled

TIPO TYPE	TENSIONE VOLTAGE (VOLT)	FREQU. AL GINOCCHIO (HZ)	FREQU. (HZ)	GIRI (rpm)	POT. RESA OUT. POW. (KW)	ASSORB. ABSORB. (amp)	COS $\phi$	PESO WEIGHT (Kg)
AF80 9/2 CU	220	300	400	24000	1.1	5.2	0.75	8.5
AF80 9/2 CU	380	300	400	24000	1.1	3.0	0.75	8.5
AF80 9/2 CU	220	400	670	40000	1.4	5.8	0.75	8.5
AF80 9/2 CU	380	400	670	40000	1.4	3.3	0.75	8.5

### Elettromandri AF80 9/2 CU

Elettromandrino AF80 CU con cambio utensile automatico ISO 20  
Electric spindle AF80 CU with automatic tool change ISO 20

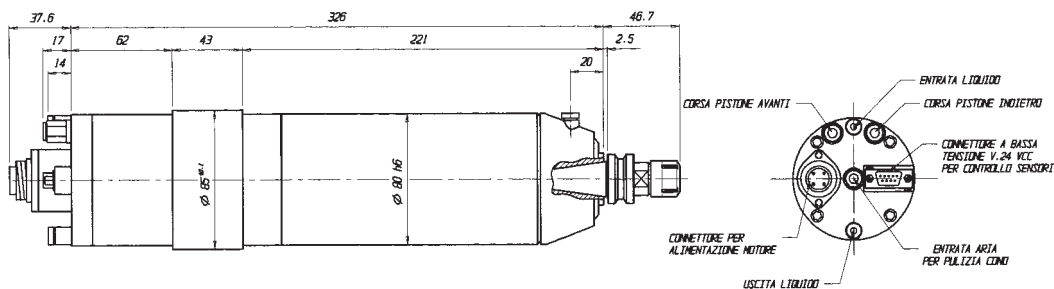

## Serie AF Raffreddato a liquido Liquid Cooled

TIPO TYPE	TENSIONE VOLTAGE (VOLT)	FREQU. AL GINOCCHIO (HZ)	FREQU. (HZ)	GIRI (rpm)	POT. RESA OUT. POW. (KW)	ASSORB. ABSORB. (amp)	COS $\phi$	PESO WEIGHT (Kg)
AF100 7/2	220	300	400	24000	1.8	7.8	0.80	8
AF100 7/2	380	300	400	24000	1.8	4.5	0.80	8
AF100 7/2	220	400	670	40000	2.2	8.5	0.80	8
AF100 7/2	380	400	670	40000	2.2	4.9	0.80	8

### Elettromandri AF100 7/2 Electric spindles AF100 7/2

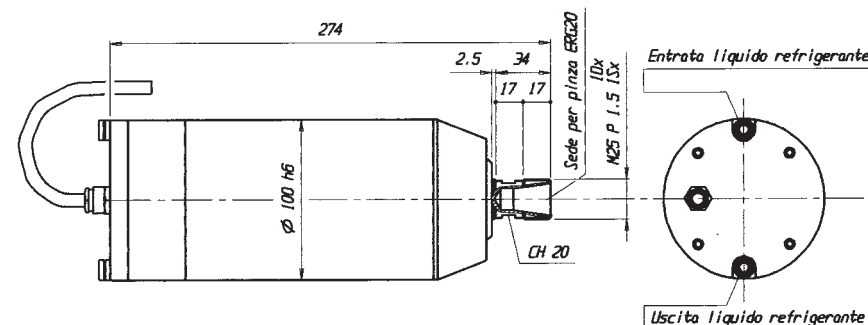

**Ghiera ER 20** Ring nut ER 20  
**Pinza ER 20** Collet ER 20

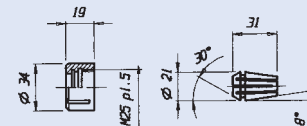

**Diametro Min. 1 Max 13 mm.**  
Diameter Min. 1 Max 13 mm.

**NB: Pinza e ghiera vengono fornite a richiesta.**  
NB: Collet and ring nut only on your request.



**AF80 CU**

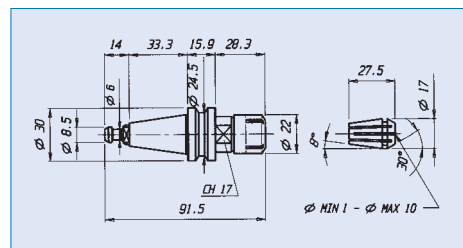

**Cono ISO 20 con attacco per pinza ER 16 e ghiera ER 16 mini**  
Iso 20 taper for collet ER 16 and ring nut ER 16 mini



**AF100**

## Serie AF Raffreddato a liquido Liquid Cooled

TIPO TYPE	TENSIONE VOLTAGE (VOLT)	FREQU. AL GINOCCHIO (HZ)	FREQU. (HZ)	GIRI (rpm)	POT. RESA OUT. POW. (KW)	ASSORB. ABSORB. (amp)	COS $\phi$	PESO WEIGHT (Kg)
AF100 7/2 CU	220	300	400		1.8	7.8	0.80	12
AF100 7/2 CU	380	300	400		1.8	4.5	0.80	12
AF100 7/2 CU	220	400	670		2.2	8.5	0.80	12
AF100 7/2 CU	380	400	670		2.2	4.9	0.80	12

### Elettromandri AF100 7/2 CU

Elettromandrino AF100 7/2 CU con cambio utensile automatico ISO 20  
Electric spindle AF100 7/2 CU with automatic tool change ISO 20

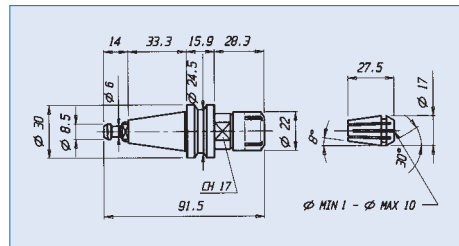
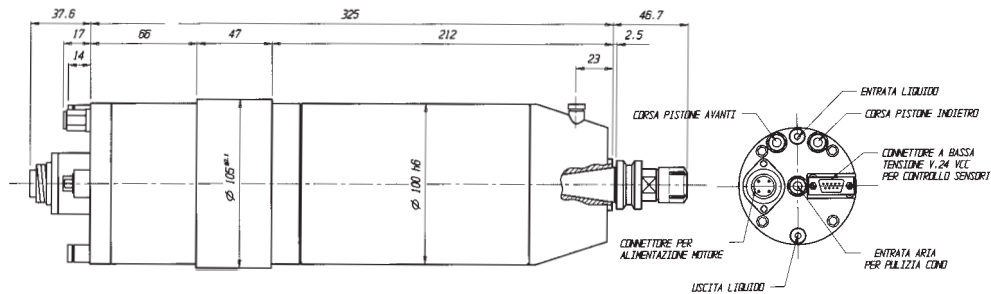

Cono ISO 20 con attacco per pinza ER 16 e ghiera ER 16 mini  
ISO 20 taper for collet ER 16 and ring nut ER 16 mini

## Serie AF

Dimensioni dei supporti  
per mandrini  
Dimensions of the spindles  
holders

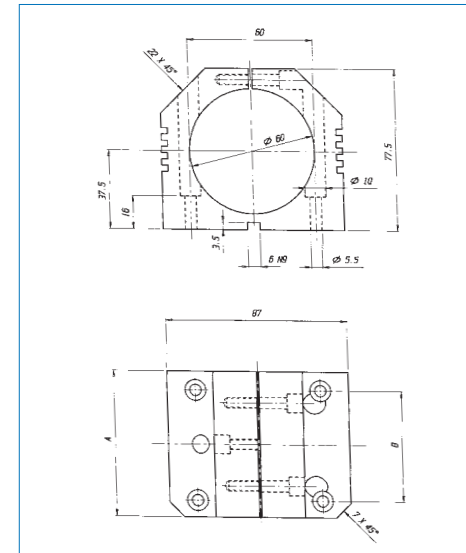

AF60

TIPO TYPE	A	B
AF60 2.5/2	50	33
AF60 6/2	70	53

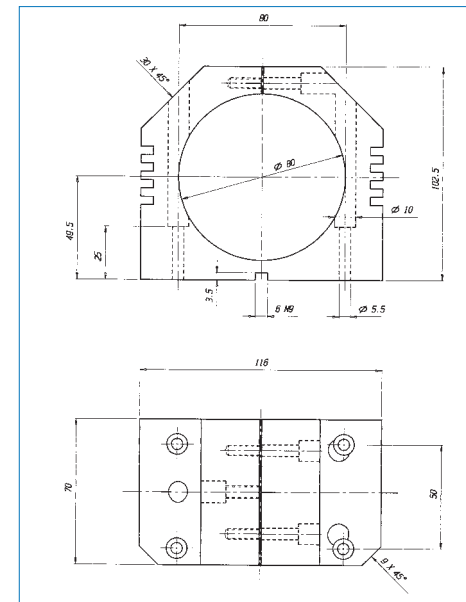

AF 80 - AF 80CU

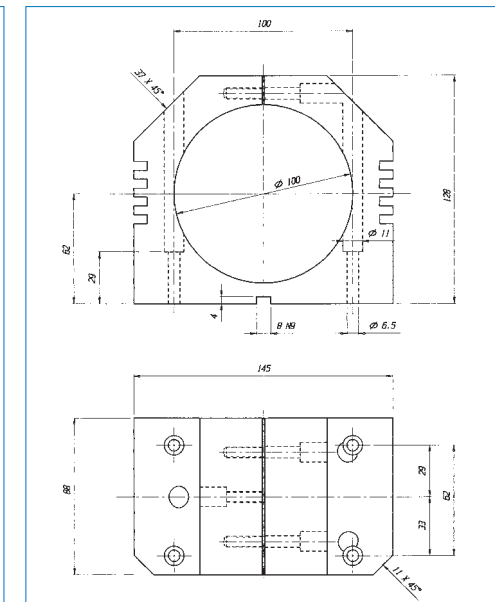

AF 100 - AF 100CU

## Serie AF Raffreddato a liquido Liquid Cooled

TIPO TYPE	TENSIONE VOLTAGE (VOLT)	FREQU. AL GINOCCHIO (HZ)	FREQU. (HZ)	GIRI (rpm)	POT. RESA OUT. POW. (KW)	ASSORB. ABSORB. (amp)	COS $\phi$	PESO WEIGHT (Kg)
AF90 10/2	380	200	300	18000	4	8.7	0.81	14
	380	300	400	24000	4.6	11.4	0.82	14

### Elettromandrini AF90 10/2 Electric spindles AF90 10/2

Sporgenza per pinza ER 25  
Nose type for collet ER 25

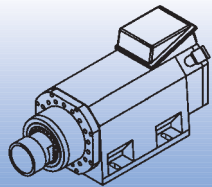
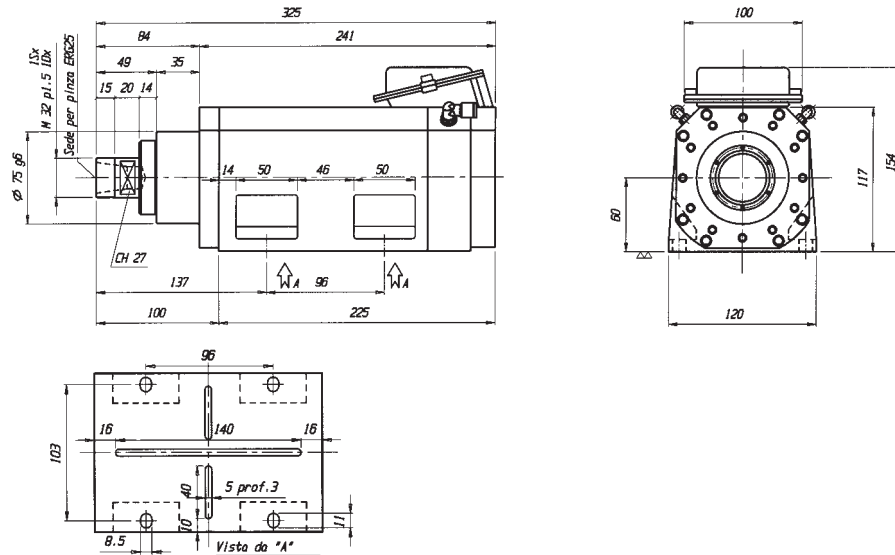

**AF90**

**Ghiera ER 25**      **Pinza ER 25**  
Ring nut ER 25      Collet ER 25

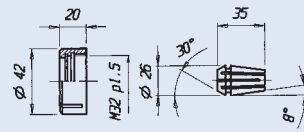

**Diametro Min. 1 Max. 16 mm.**  
Diameter Min. 1 Max. 16 mm.

**NB: Pinza e ghiera vengono fornite a richiesta.**  
NB: Collet and ring nut only on your request.

## Serie AF Raffreddato a liquido Liquid Cooled

TIPO TYPE	TENSIONE VOLTAGE (VOLT)	FREQU. AL GINOCCHIO (HZ)	FREQU. (HZ)	GIRI (rpm)	POT. RESA OUT. POW. (KW)	ASSORB. ABSORB. (amp)	COS $\phi$	PESO WEIGHT (Kg)
AF90 10/2 CU	350	400	500	30000	4	9.4	0.80	18
ISO 20								

### Elettromandrini AF90 10/2 CU Electric spindles AF90 10/2 CU

Versione con cono ISO 20  
ISO 20 taper version

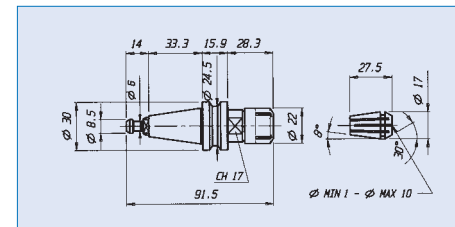
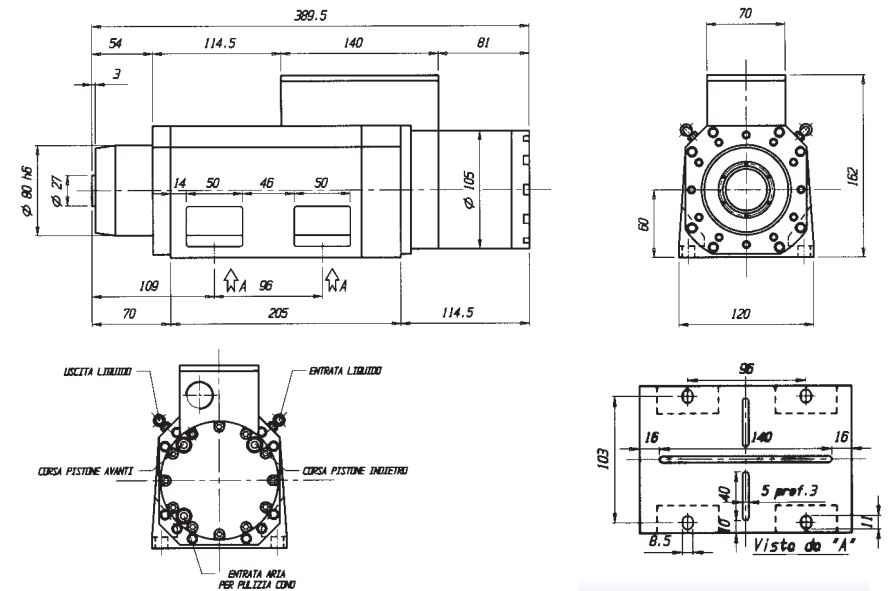

**Cono ISO 20 con attacco per pinza ER 16 e ghiera ER 16 mini**  
ISO 20 taper for collet ER 16 and ring nut ER 16 mini

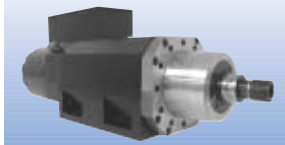

**AF90 CU  
ISO 20**

## Serie AF Raffreddato a liquido Liquid Cooled

TIPO TYPE	TENSIONE VOLTAGE (VOLT)	FREQU. AL GINOCCHIO (HZ)	FREQU. (HZ)	GIRI (rpm)	POT. RESA OUT. POW. (KW)	ASSORB. ABSORB. (amp)	COS $\phi$	PESO WEIGHT (Kg)
AF90 10/2 CU	350	300	400	24000	4	9.4	0.80	18
ISO 30								

### Elettromandrini AF90 10/2 CU Electric spindles AF90 10/2 CU

Versione con cono ISO 30  
ISO 30 taper version

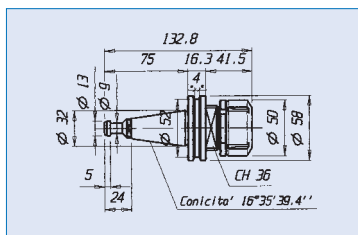
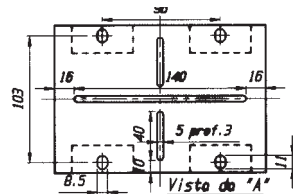
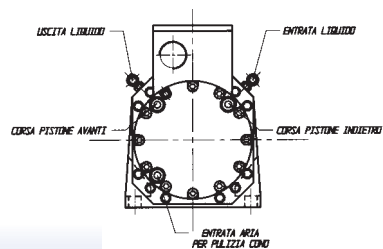
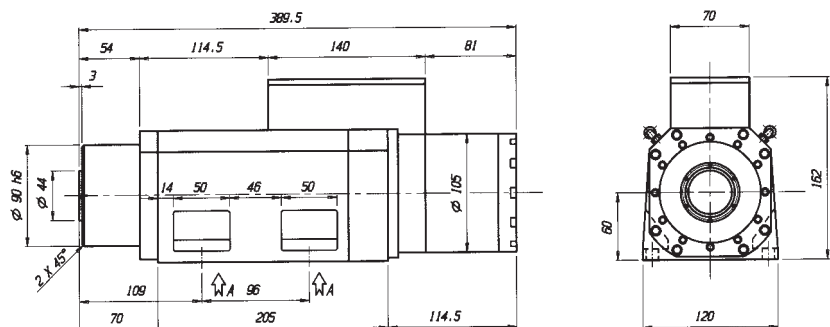

Diametro Min. 1  
Max 20 mm.  
Diameter Min. 1  
Max 20 mm.

Cono ISO 30 con attacco per pinza ER 32  
Iso 30 taper for collet ER 32

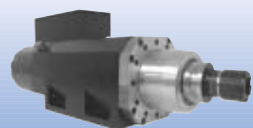

**AF90 CU**  
**ISO 30**

## Serie AF Raffreddato a liquido Liquid Cooled

TIPO TYPE	TENSIONE VOLTAGE (VOLT)	FREQU. AL GINOCCHIO (HZ)	FREQU. (HZ)	GIRI (rpm)	POT. RESA OUT. POW. (KW)	ASSORB. ABSORB. (amp)	COS $\phi$	PESO WEIGHT (Kg)
AF110 14/2	380	200	300	18000	7.5	16.8	0.85	28
	380	300	400	24000	8.5	19.4	0.82	28

### Elettromandrini AF110 14/2 Electric spindles AF110 14/2

Sporgenza per pinza ER 32  
Nose type for collet ER 32

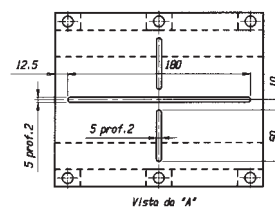
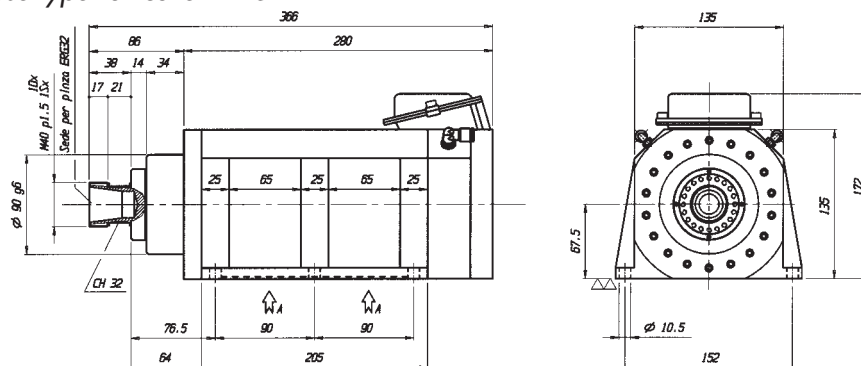

Ghiera ER 32  
Ring nut ER 32

Pinza ER 32  
Collet ER 32

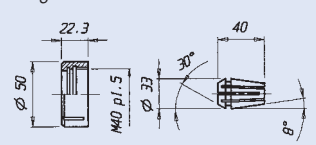

Diametro Min. 1 Max. 20 mm.  
Diameter Min. 1 Max. 20 mm.

NB: Pinza e ghiera vengono fornite a richiesta.  
NB: Collet and ring nut only on your request.

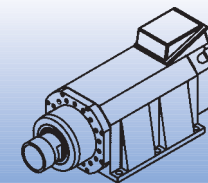

**AF110**



## Serie AF Raffreddato a liquido Liquid Cooled

TIPO TYPE	TENSIONE VOLTAGE (VOLT)	FREQU. AL GINOCCHIO (HZ)	FREQU. (HZ)	GIRI (rpm)	POT. RESA OUT. POW. (KW)	ASSORB. ABSORB. (amp)	COS $\phi$	PESO WEIGHT (Kg)
AF110 14/2	380	100	200	12000	5	10	0.82	28
	380	200	300	18000	7.5	16.8	0.85	28

### Elettromandrini AF110 14/2 Electric spindles AF110 14/2

Sporgenza per pinza ER 40  
Nose type for collet ER 40

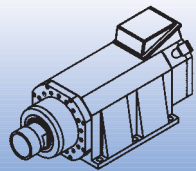
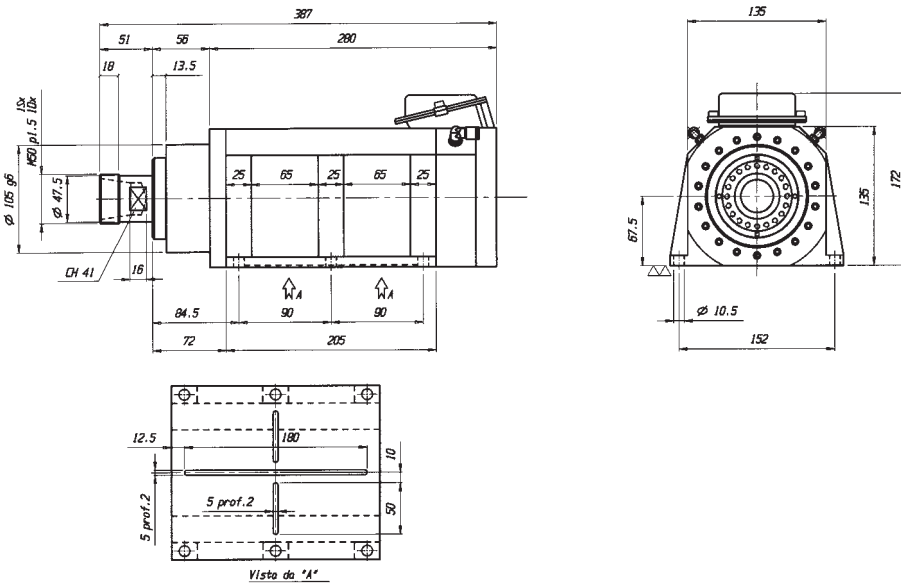

**AF110**

**Ghiera ER 40**  
Ring nut ER 40

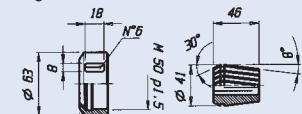

**Pinza ER 40**  
Collet ER 40

**Diametro Min. 3 Max. 30 mm.**  
Diameter Min. 3 Max. 30 mm.

NB: Pinza e ghiera vengono fornite a richiesta.  
NB: Collet and ring nut only on your request.

## Serie AF Raffreddato a liquido Liquid Cooled

TIPO TYPE	TENSIONE VOLTAGE (VOLT)	FREQU. AL GINOCCHIO (HZ)	FREQU. (HZ)	GIRI (rpm)	POT. RESA OUT. POW. (KW)	ASSORB. ABSORB. (amp)	COS $\phi$	PESO WEIGHT (Kg)
AF110 14/2 CU	350	200	300	18000	7.5	18	0.85	32
ISO 30	350	300	400	24000	8.5	19.9	0.82	32

### Elettromandrini AF110 14/2 CU Electric spindles AF110 14/2 CU

Versione con cono ISO 30  
ISO 30 taper version

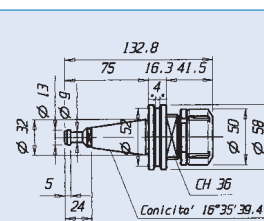
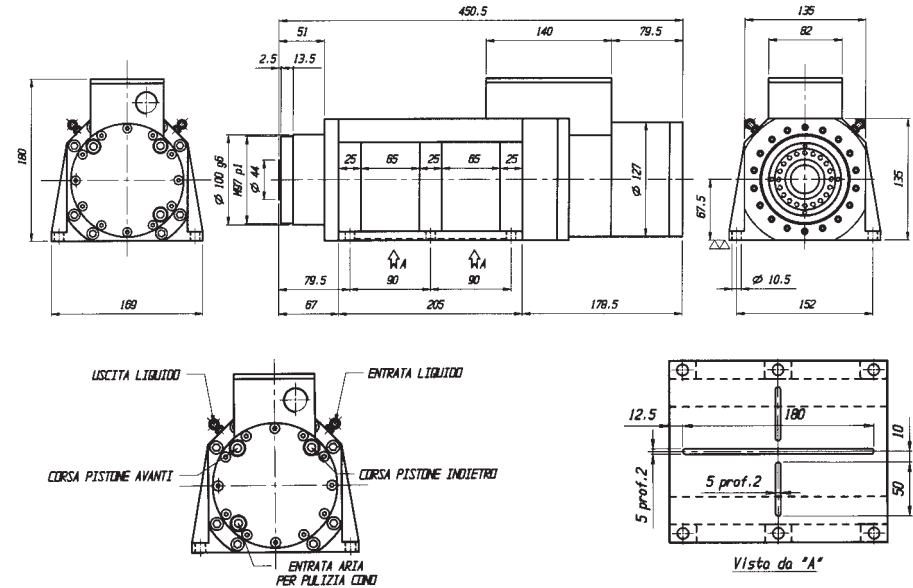

**Cono ISO 30 con attacco per pinza ER 32**  
Iso 30 taper for collet ER 32

**Diametro Min. 1  
Max 20 mm.**  
Diameter Min. 1  
Max 20 mm.



**AF110 CU  
ISO 30**



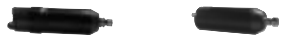

## Serie AF

### Scambiatore di calore aria-acqua

*Air-water heat exchanger*

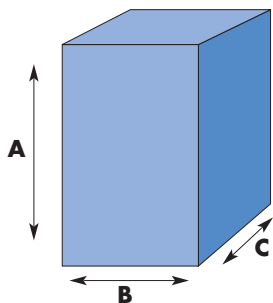

RF.005.3R.VE



TIPO Type	A	B	C
AF60			
AF80	40	48	23

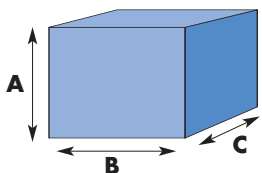

RF.01.4R.VE



TIPO Type	A	B	C
AF100			
AF80 CU	41	65	40

## Refrigeratore d'acqua con vasca e pompa

*Water chiller unit with tank and pump*

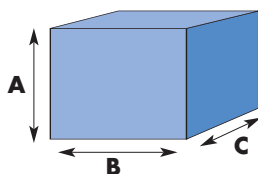

KRA 10 AF  
KRA 15 AF

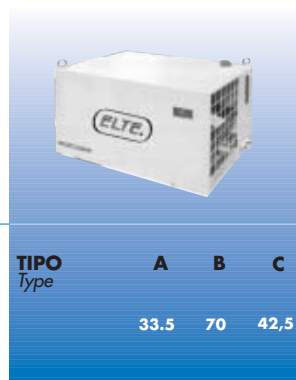

TIPO Type	A	B	C
KRA 10 AF	33,5	70	42,5
KRA 15 AF			

## SERIE ELETTROMANDRINI SEMIAUTOMATICI CON INVERTER INCORPORATO

Serie di elettromandrini con scheda inverter integrata per azionamenti a velocità variabile (mediante potenziometro), questa tipologia assicura semplicità di alimentazione ed economicità di applicazione. Vengono notevolmente ridotti anche i costi di cablaggio, acquisto inverter e cavi schermati.

### Specifiche tecniche:

- Alimentazione monofase 230V (+20%) frequenza 45-65Hz
- Regolazione della velocità mediante potenziometro
- Tensione frequenza e uscita già tarate
- Controllo della presenza di alimentazione dell'inverter
- Controllo delle fasi in uscita (mancanza fase, assorbimento elevato)
- Protezione per sovra temperatura
- Inversione del senso di rotazione mediante jumper
- Frequenza in uscita da 40 a 400 Hz
- Potenza massima disponibile 1Kw

### È disponibile inoltre una scheda opzionale con le seguenti funzionalità:

- Comando di velocità con segnale analogico 0/+10V isolato
- Comando inversione marcia con segnale isolato
- Comando start/stop con segnale isolato
- Uscita optoisolata denominata drive-ok per segnale inverter in anomalia
- Uscita optoisolata per segnalazione frequenza raggiunta

Offriamo la nostra disponibilità per valutare ulteriori richieste ed eventuali modifiche su specifiche del cliente.

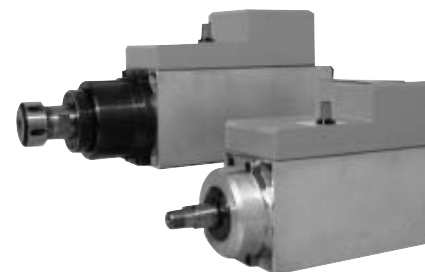

**N.B.** La realizzazione di questa nuova serie di elettromandrini con inverter integrato e' possibile su tutte le nostre serie con potenza max di 1KW e frequenza variabile da 50 a 400 HZ. Siamo in fase di progettazione anche per potenze superiori.

## SET OF ELECTRIC SEMIAUTOMATIC SPINDLES WITH INCORPORATED INVERTER

Set of electric spindles with integrated inverter card for operations at variable speeds (by means of a potentiometer), this type of electric spindles guarantee simplicity of feeding and economic application. Consequently also the harness costs are dramatically reduced with no need to buy the inverter and the shielded cables.

### Technical features:

- Single phase input 230 V (+/-20%) frequency 45-65Hz
- Speed regulation by means of a potentiometer
- Voltage and output frequency are already set
- Checkout of the presence of the inverter feeding
- Checkout of the output phases (missing phase, high absorption)
- Over temperature protection
- Reversal of the direction of rotation by means of a jumper
- Output frequency from 40 to 400 Hz
- Max power available 1 Kw

### Optional card with the following functionalities:

- Speed control with insulated analog signal 0/+10V
- Reverse control with insulated signal
- Start/stop control with insulated signal
- Optoinsulated exit called drive-ok to signal defect inverter
- Optoinsulated exit to signal reached frequency

We are at your disposal to value further requests and possible modifications based on customer's specifications.

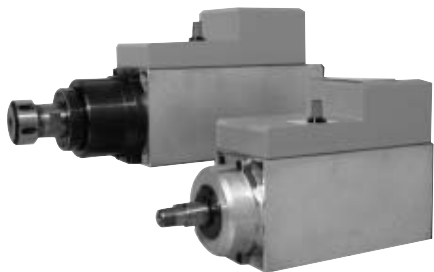

**Important:** It is possible to carry out this new brand of electric spindles with incorporated inverter on all our series with max power 1 Kw and frequency variable from 50 to 400 Hz. We are working on the same project also for higher power.



## Serie Convertitori statici da 0.55 Kw a 60Kw Inverter

TESTATO E MARCATO **ELTE** CHE GARANTISCE IL FUNZIONAMENTO ALLE MASSIME PRESTAZIONI CON I PROPRI MANDRINI

### Tecnologia affidabile, compatto, robusto facile da usare.

#### Caratteristiche:

Inverter vettoriale con calcolo del vettore in automatico ogni millisecondo verso il motore, calcolando anche i relativi cavi di connessione, utilizzando i valori istantanei misurati. Il processore Vacon si basa sul controllo vettoriale Sensorless con modello matematico di simulazione e sul circuito ASIC. Il controllo vettoriale avviene sfruttando il sistema di coordinate del flusso magnetico di statore. Il calcolo rimane così insensibile alle variazioni delle grandezze elettriche del motore.

- L'errore sulla velocità in situazione stazionaria è inferiore a 0.5 %.
- Il tempo di risposta della coppia è inferiore a 10 ms.
- Non c'è oscillazione di coppia.
- Non è sensibile a vibrazioni di risonanza.
- Coppia di spunto elevata: 200 %.
- Corrente di spunto elevata: 2.5 x ict.
- Adatto anche a sistemi multi- motore.
- Massima frequenza d'uscita 1.000 Hz.
- Filtro doppia gabbia per compatibilità "EMC" EN50081-2 (interno).
- Reattanza di linea trifase a pacco lamellare a.c (interna). Diminuisce le armoniche verso rete del 30%, protegge l'Inverter da extracorrenti e impurità di linea, diminuisce la corrente d'ingresso, etc.
- Filtro lato motore (interno).
- Chopper di frenatura (interno) dimensionato per frenare fino al 150 % in frequenza massima d'uscita fino a 1.000 Hz.

- Frequenza di commutazione verso il motore da 1 a 16 KHz tarabile linearmente da tastiera, rende silenzioso il motore fornendo un'onda sinusoidale senza creare problemi di disturbi.
- Disponibili due relè configurabili con contatti da 3° 220 / 240 Vca.
- Tastiera alfanumerica estraibile multi-lingua (Tedesco- Italiano – Francese – Inglese- Spagnolo, etc).
- Seriale RS 232 per programmazione/diagnostica da tastiera PC.
- Possibilità di tarare il motore con tensione e frequenze d'uscita a scelta (es. Inverter alimentato a 380Vca può alimentare uno o più mandrini a 220Vca 800 Hz, etc) reimpostandole all'interno dell' Inverter fino al massimo di 8 tipi diversi.
- Possibilità di mantenere costante nel tempo il valore di tensione in uscita, anche con variazioni di tensioni d'ingresso (alimentazione rete).
- Applicazione multi- tabella per gestire fino a 8 motori diversi con un unico Inverter.
- Software per gestione con controllo P.I. interno.
- L'Inverter permette di usare cavi motore con lunghezza massima fino a 200 mt senza usare nessuna reattanza esterna per l'abbassamento del fattore capacitivo dei cavi.
- Possibilità di avere l'Inverter sia in versione IP-20 che IP-54 con tensioni trifasi da 208 % - 15 % fino a 690 Vca +15.
- Tutti gli Inverter Vacon sono marchiati CE UL e c- UL standard produttivo ISO- 9001 (soddisfa in termini di sicurezza EN50178, EN60204-1, FI, GOST R).

TIPO	MONOFASE		TRIFASE		PESO (Kg)	Induttanza di linea trifase filtro e toroide per EMS unità di frenata interna
	Potenza (Kw)	Corrente motore (A)	Potenza (Kw)	Corrente motore (A)		
<b>NXS00072</b>	0.75	4.8	1.1	6.6	5	INCLUSO
<b>NXS00082</b>	1.1	6.6	1.5	7.8	5	INCLUSO
<b>NXS00112</b>	1.5	7.8	2.2	11	5	INCLUSO
<b>NXS00122</b>	2.2	11	3	12.5	5	INCLUSO
<b>NXS00172</b>	3	12.5	4	17.5	8.1	INCLUSO
<b>NXS00252</b>	4	17.5	5.5	25	8.1	INCLUSO
<b>NXS00312</b>	5.5	25	7.5	31	8.1	INCLUSO

- **ALIMENTAZIONE 208-230 VOLT Hz 50/60 3~.**
- **USCITA INVERTER 220 VOLT Hz 1000.**

TIPO	TRIFASE		PESO (Kg)	Induttanza di linea trifase filtro e toroide per EMS unità di frenata interna	TAGLIA
	Potenza (Kw)	Corrente motore (A)			
<b>NXS00035</b>	1.1	3.6	5	INCLUSO	FR 4
<b>NXS00045</b>	1.5	4.7	5	INCLUSO	FR 4
<b>NXS00055</b>	2.2	6.2	5	INCLUSO	FR 4
<b>NXS00075</b>	3	8.4	5	INCLUSO	FR 4
<b>NXS00095</b>	4	9.9	5	INCLUSO	FR 4
<b>NXS00125</b>	5.5	13.2	5	INCLUSO	FR 4
<b>NXS00165</b>	7.5	17.6	8.1	INCLUSO	FR 5
<b>NXS00225</b>	11	25	8.1	INCLUSO	FR 5
<b>NXS00315</b>	15	34	8.1	INCLUSO	FR 5
<b>NXS00385</b>	18.5	42	18.5	INCLUSO	FR 6
<b>NXS00455</b>	22	51	18.5	INCLUSO	FR 6

- **ALIMENTAZIONE 380-400 VOLT Hz 50/60 3~.**
- **USCITA INVERTER 380-400 VOLT Hz 1000.**

La **ELTE** s.r.l. utilizza, oltre la serie sopra indicata, Inverters sperimentati sui propri mandrini e risultanti di ottima qualità della **EUROTHERM DRIVES** e **BERGES** i quali possono essere normalmente forniti su richiesta.

## Raffreddamento

Per assicurare una efficace circolazione dell'aria lo spazio libero attorno all'inverter deve avere determinate dimensioni (vedi Tab. 1). Qualora si volessero montare unità multiple una sopra l'altra la distanza deve essere uguale a b+c.

### Spazio di installazione e dimensioni di montaggio

DIMENSIONI	FR4	FR5	FR6	FR7	FR8	FR9	FR10
A - Altezza	327	419	558	630	755	1150	1130
B - Larghezza	128	144	195	237	285	476	471
C - Profondità	190	214	237	257	312	362	420
Quote di fissaggio							
A - Altezza	313	406	541	614	732	1120	833
B - Larghezza	100	100	148	190	255	400	380
C - Diametro	M6	M6	M8	M8	M8	M8	M10

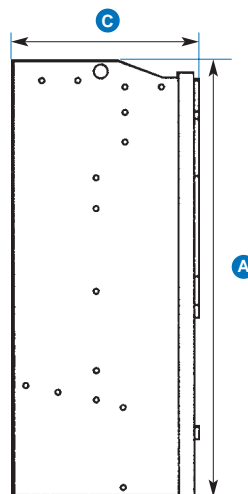
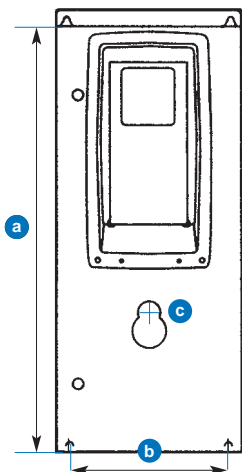
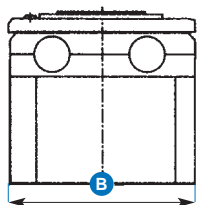

## Static frequency converters (Inverters) 0.55 Kw up to 60 Kw

TESTED AND MARKED **ELTE** WHICH ENSURES THE OPERATION AT THE MAXIMUM PERFORMANCES WITH ITS OWN ELECTRIC SPINDLES



### RELIABLE TECHNOLOGY, COMPACT, STRONG, EASY TO USE

#### Operating features:

Vectorial inverter with automatic calculation of the Vector each millisecond to the motor, calculating also the related connection cables, by using the instantaneous values measured. The Vacon processor is based on the vectorial control Sensorless with mathematic model of emulation and on the ASIC circuit. The vectorial control is made by exploiting the coordinates system of the magnetic flow of the stator. In this way the calculation remains insensitive to the variation of the electric magnitude of the motor.

- The on speed error under fixed situation is lower than 0.5.
- The response time of the torque is lower than 10 ms.
- No torque oscillation.
- No sensitive to resonance vibrations.
- High starting torque: 200 %.
- High breakaway starting current: 2.5 x ict.
- Suitable also for multi-motor systems.
- Maximum output frequency 1.000 hz.
- Double cage filter for compatibility to "EMC" EN50081-2 (Internal).
- Three phase line reactance by a.c lamellar packet (internal). It reduces the harmonics to the mains by 30%, protects the inverter against extra-currents and line impurities, it reduces the input current etc.
- Filter on the motor side (internal).
- Braking chopper (internal) sized to brake up to 150%.

- Maximum frequency up to 1.000 Hz.
- Commutation frequency to the motor from 1 to 16 KHz which can be calibrated linearly from the keyboard; it makes the motor silenced, providing a sinusoidal wave with no interferences.
- Two configurable relays with contacts from 3a 220/240 Vca are available.
- Multilingual detachable alphanumeric keyboard (German-Italian-French-English-Spanish, etc.).
- Serial RS 232 for programming/diagnostics from keyboard to PC.
- Possibility to calibrate the motor with output voltages and frequencies by choice (ex. An inverter supplied at 380 Vac may supply one or more spindles at 220 Vac 800 Hz, etc.) presetting them inside the inverter up to maximum of 8 different types.
- Possibility to keep constant along the time the value of the output voltage, also with variations of the input voltages (mains power supply).
- Management software with an internal P.I control.
- The Inverter allows to use motor cables with maximum length up to 200 m without using any external reactance to reduce the capacitive factor of the cables.
- Possibility to receive the inverter either in Version IP-20 or IP-54 with three-phase voltages from 208 – 15% up to 690 Vca +15.
- All Vacon inverters are marked CE UL and c-UL., manufacturing standard ISO-9001 (it meets the safety terms EN50178, EN60204-1, FI, GOST R).

TYPE	SINGLE PHASE		THREE PHASE		WEIGHT (Kg)	Three-Phase inductance filter and toroid for EMS internal braking
	Power (Kw)	Current motor (A)	Power (Kw)	Current motor (A)		
<b>NXS00072</b>	0.75	4.8	1.1	6.6	5	INCLUDED
<b>NXS00082</b>	1.1	6.6	1.5	7.8	5	INCLUDED
<b>NXS00112</b>	1.5	7.8	2.2	11	5	INCLUDED
<b>NXS00122</b>	2.2	11	3	12.5	5	INCLUDED
<b>NXS00172</b>	3	12.5	4	17.5	8.1	INCLUDED
<b>NXS00252</b>	4	17.5	5.5	25	8.1	INCLUDED
<b>NXS00312</b>	5.5	25	7.5	31	8.1	INCLUDED

- **INPUT 208-230 VOLT Hz 50/60 3~.**
- **OUTPUT INVERTER 220 VOLT Hz 1000.**

TYPE	THREE PHASE		WEIGHT (Kg)	Three-Phase inductance filter and toroid for EMS internal braking	FRAME SIZE
	Power (Kw)	Current motor (A)			
<b>NXS00035</b>	1.1	3.6	5	INCLUDED	FR 4
<b>NXS00045</b>	1.5	4.7	5	INCLUDED	FR 4
<b>NXS00055</b>	2.2	6.2	5	INCLUDED	FR 4
<b>NXS00075</b>	3	8.4	5	INCLUDED	FR 4
<b>NXS00095</b>	4	9.9	5	INCLUDED	FR 4
<b>NXS00125</b>	5.5	13.2	5	INCLUDED	FR 4
<b>NXS00165</b>	7.5	17.6	8.1	INCLUDED	FR 5
<b>NXS00225</b>	11	25	8.1	INCLUDED	FR 5
<b>NXS00315</b>	15	34	8.1	INCLUDED	FR 5
<b>NXS00385</b>	18.5	42	18.5	INCLUDED	FR 6
<b>NXS00455</b>	22	51	18.5	INCLUDED	FR 6

- **INPUT 380-400 VOLT Hz 50/60 3~.**
- **OUTPUT INVERTER 380-400 VOLT Hz 1000.**

For assuring proper cooling air circulation the space around the Inverter should have determinate dimensions. See under mentioned table for dimensions. If multiple units are to be installed above each other, the dimensions must be B + C and air from outlet lower unit must be directed away from inlet of the upper unit.

## Installation space dimensions e mounting dimensions

DIMENSIONS	FR4	FR5	FR6	FR7	FR8	FR9	FR10
A - Height	327	419	558	630	755	1150	1130
B - Width	128	144	195	237	285	476	471
C - Depth	190	214	237	257	312	362	420
FASTENING DIM.							
A - Height	313	406	541	614	732	1120	833
B - Width	100	100	148	190	255	400	380
C - Fastening bolt size	M6	M6	M8	M8	M8	M8	M10

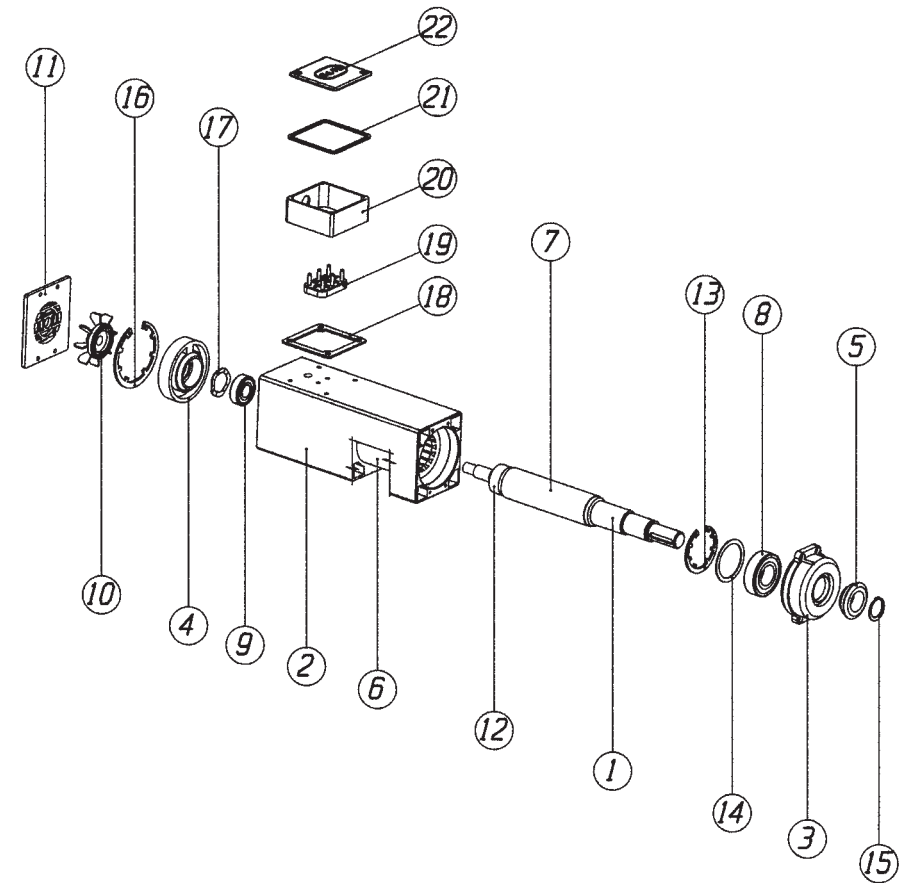
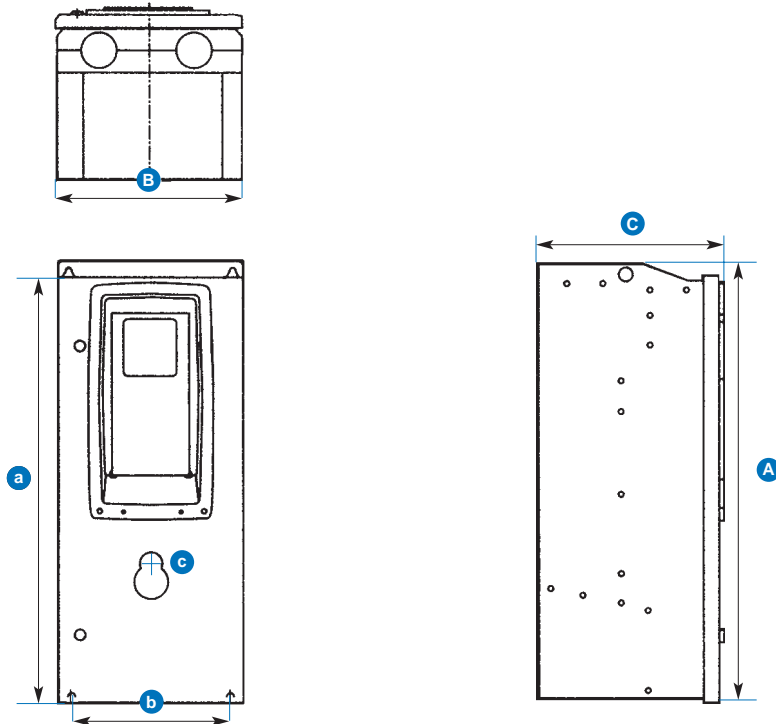

POS.	DESCRIZIONE
1	ALBERO
2	CARASSA
3	COPERCHIO ANTERIORE
4	COPERCHIO POSTERIORE
5	LABIRINTO
6	STATORE AVVOLTO
7	ROTORE
8	CUSCINETTO ANTERIORE
9	CUSCINETTO POSTERIORE
10	VENTOLA
11	PIASTRINA COPRIVENTOLA
12	BUSSOLA DI BILANCIATURA
13	SEEGER PER INTERNI
14	DISTANZIALE
15	SEEGER
16	SEEGER PER INTERNI
17	MOLLA DI COMPENSAZIONE
18	GUARNIZIONE BASE
19	MORSETTIERA
20	COPRIMORSETTIERA
21	GUARNIZIONE COPERCHIO
22	COPERCHIO COPRIMORSETTIERA

POS.	DESCRIPTION
1	SHAFT
2	FRAME
3	FRONT COVER
4	REAR COVER
5	LABYRINTH SEAL
6	WOUND STATOR
7	ROTOR
8	FRONT BEARING
9	REAR BEARING
10	FAN
11	FAN COVER PLATE
12	BALANCING BUSH
13	"0" RING
14	DISTANCE RING
15	"0" RING
16	"0" RING
17	COMPENSATION SPRING
18	GASKET
19	TERMINAL BOARD
20	TERMINAL COVER
21	COVER GASKET
22	TERMINAL BOARD COVER

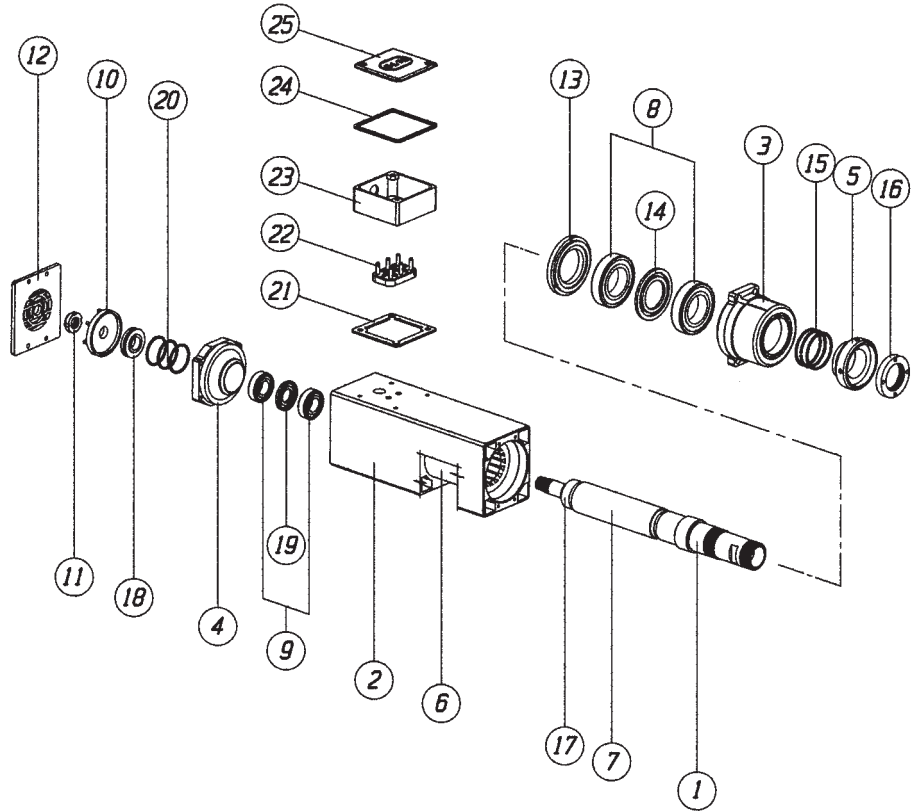

POS.	DESCRIZIONE
1	ALBERO
2	CARCASSA
3	COPERCHIO ANTERIORE
4	COPERCHIO POSTERIORE
5	LABIRINTO
6	STATORE AVOIUTO
7	ROTORE
8	COPPIA CUSCINETTO ANTERIORE
9	COPPIA CUSCINETTO POSTERIORE
10	VENTOLA
11	GHIERA AUTOBLOCCANTE
12	PIASTRINA COPRIVENTOLA
13	GHIERA BLOCCA COPPIA
14	DISTANZIALE
15	SEGMENTI LAMELLARI
16	CONTROGHIERA ANTERIORE
17	BUSSOLA DI BILANCIATURA
18	GHIERA BLOCCA COPPIA
19	DISTANZIALE
20	SEGMENTI LAMELLARI
21	GUARNIZIONE BASE
22	MORSETTIERA
23	COPRIMORSETTIERA
24	GUARNIZIONE COPERCHIO
25	COPERCHIO COPRIMORSETTIERA

POS.	DESCRIPTION
1	SHAFT
2	FRAME
3	FRONT COVER
4	REAR COVER
5	LABIRYNTH SEAL
6	WOUND STATOR
7	ROTOR
8	FRONT PAIR OF BEARINGS
9	REAR PAIR OF BEARINGS
10	FAN
11	SELFLOCKING NUT
12	FAN COVER PLATE
13	BEARINGS PAIR - LOCKING NUT
14	DISTANCE RING
15	LAMELLAR SEGMENTS
16	FRONT NUT
17	BALANCING BUSH
18	BEARINGS PAIR - LOCKING NUT
19	DISTANCE RING
20	LAMELLAR SEGMENTS
21	GASKET
22	TERMINAL BOARD
23	TERMINAL COVER
24	COVER GASKET
25	TERMINAL BOARD COVER

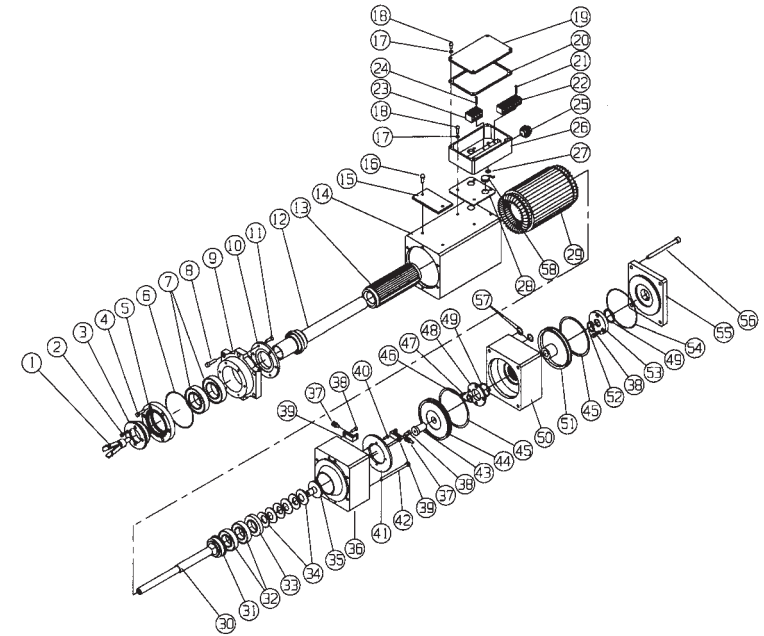

POS.	DESCRIZIONE	POS.	DESCRIZIONE	POS.	DESCRIZIONE
1	PINZA CAMBIO RAPIDO	21	VITE M3x16	41	FLANGIA CHIUSURA ARIA
2	VITE M4x14	22	MORSETTO MK3/8	42	VITE M6x80
3	GHIERA LABIRINTO	23	VITE M3x20	43	PERNO BLOCC. PISTONE
4	VITE M5x20	24	MORSETTO BK4	44	PISTONE INFERIORE
5	FLANGIA ANTERIORE	25	PRESSACAVO NYLON 3/4"	45	GUARNIZIONE OR 6375
6	GUARNIZIONE OR 2350	26	CORPO BASETTA MOTORE	46	GUARNIZIONE OR 2068
7	CUSCINETTI	27	GUARNIZIONE OR 109	47	VITE M4x12
8	VITE M6x20	28	GUARNIZIONE SCATOLA MORSETTIERA	48	FLANGIA TEFLON DM.30
9	CORPO CALOTTA INFERIORE	29	STATORE	49	GUARNIZIONE OR 3118
10	FLANGIA POSTERIORE	30	ALBERINO BLOCC., SBLOCC.	50	CALOTTA DOPPIA CILINDRO SBLOCC.
11	VITE M5x16	31	DISTANZIALE ROTORE	51	PISTONE SUPERIORE
12	ALBERO MOTORE FRESA	32	CUSCINETTO	52	GUARNIZIONE OR 3081
13	ROTORE	33	GHIERA BLOCCAGGIO CUSCINETTO	53	GUARNIZIONE IN TEFLON
14	CARCASSA MOTORE	34	MOLLA A TAZZA	54	GUARNIZIONE OR 2400
15	TARGA IDENTIFICAZIONE MOTORE	35	PERNO MOLLE	55	CALOTTA CILINDRO SBLOCCAGGIO
16	RIVETTO	36	COPERCHIO POSTERIORE	56	VITE M10x100
17	RONDELLA DENTELLATA	37	INTER. DI PROSSIMITA' MB5 26 PFAKL	57	GUARNIZIONE OR 2021
18	VITE M5x14	38	VITE M5x12	58	SONDA TERMICA
19	COPERCHIO MORSETTIERA	39	STAFFA INTERRUTTORE		
20	GUARNIZIONE COPERCHIO MORSETTIERA	40	VITE M4x10		

POS.	DESCRIPTION	POS.	DESCRIPTION	POS.	DESCRIPTION
1	SPRING COLLET	21	SCREW M3x16	41	AIR FLANGE CHOKING
2	SCREW M4x14	22	TERMINAL MK3/8	42	SCREW M6x80
3	LOCK NUT	23	SCREW M3x20	43	PISTON CLAMPING NUT
4	SCREW M5x20	24	TERMINAL BK4	44	LOWER PISTON
5	FRONT FLANGE	25	GLAND	45	"O" RING 6375
6	"O" RING 2350	26	TERMINAL BOARD CASING	46	"O" RING 2068
7	PAIR OF AC BEARINGS	27	"O" RING 109	47	SCREW M4x12
8	SCREW M6x20	28	TERMINAL BOARD GASKET	48	TEFLON FLANGE
9	FRONT BEARINGS SUPPORT	29	STATOR	49	"O" RING 3118
10	REAR FLANGE	30	CLAMPING COLLET INTR. SHAFT	50	TOP CYLINDER
11	SCREW M5x16	31	ROTOR SPACER	51	PISTON
12	SHAFT	32	BEARING	52	"O" RING 3081
13	ROTOR	33	BEARING CLAMPING NUT	53	GASKET
14	MOTOR CASING	34	WASHER	54	"O" RING 2400
15	NAMEPLATE	35	SPRINGS PIN	55	COVER
16	RIVET	36	REAR COVER	56	SCREW M10x100
17	WASHER	37	SENSOR	57	"O" RING 2021
18	SCREW M5x14	38	SCREW M5x12	58	PNP THERMAL PROTECTION
19	TERMINAL BOARD COVER	39	SWITCH BRACKET		
20	TERMINAL BOARD GASKET	40	SCREW M4x10		



# www.akcesoria.cnc.info.pl

Akcesoria CNC

16-300 Augustów

ul. Klubowa 4

e-mail: [biuro@cnc.info.pl](mailto:biuro@cnc.info.pl)

tel/fax: +48 87 644 36 76

tel: 602 726 995

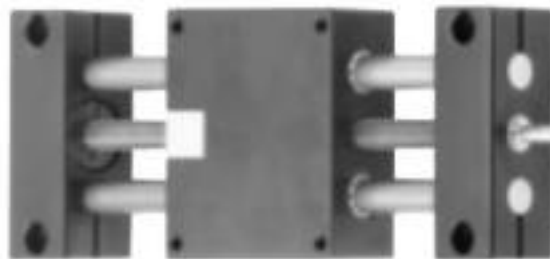

## Elementy budowy maszyn i urządzeń przemysłowych

Elementy do budowy:  
frezarek, tokarek, wypalarek plazmowych  
i innych obrabiarek numerycznych

silniki krokowe , sterownie **cnc**

sterowniki silników krokowych

serwomotory i sterowniki serwo

**elektrowrzeciona**

łożyska liniowe i inne

przewodnice liniowe - szynowe

listwy i koła zębate

pasy zębate oraz koła do pasów zębatach

śruby i nakrętki trapezowe

sprężła

falowniki

aluminiowe profile konstrukcyjne

elementy elektroniczne

przeguby, wałki, wielokliny

łańcuchy rolkowe i tulejkowe,

wysokojakościowe IWIS, w wykonaniu

specjalnym oraz akcesoria

przewodnice łańcucha, napinacze oraz koła

wałki zębate

pasy zębate do przenośników pokryte NFT,

NFB, Linatex, Tenatex, PU, Porol, HC,

Neopren, i innymi

pasy klinowe w różnym wykonaniu oraz koła

do pasów klinowych

pasy i koła Micro -V

tuleje mocujące samocentrujące i zwykłe,

Taper lock

