

## **SANYO DENKI® P3 and P5 Series Brushless motor with Hall pulses For Copley Xenus Amplifier**



### **Features**

- Smooth AC Sinusoidal Commutation
- P3 Low inertia and P5 Medium inertia.
- Rated 3000rpm from 30 to 1k Watt
- Commutating Encoder 2000 line count (8000cpr).
- P3 and P5 Metric mounting
- P5 NEMA mounting options.
- 24V Brake and IP45 shaft seal options

**P3**

Stall Torque Oz-in (Nm)	rpm	Buss Voltage	Watts	Flange in (mm)	Motor Model	Amplifier Model
15.3 (.108)	3000	200	30	1.57 (40)	P30B04003DXKST	XSL-230-18
22.2 (0.157)	3000	200	50	1.57 (40)	P30B04005DXKST	XSL-230-18
45.3 (0.32)	3000	200	100	1.57 (40)	P30B04010DXKST	XSL-230-18
97 (0.686)	3000	200	200	2.36 (60)	P30B06020DXKST	XSL-230-18
180 (1.27)	3000	200	400	2.36 (60)	P30B06040DXKST	XSL-230-18
361 (2.55)	3000	200	750	3.15 (80)	P30B08075DXKST	XSL-230-36

**P5**

Stall Torque Lb-in (Nm)	rpm	Buss Voltage	Watts	Flange in (mm)	Motor Model	Amplifier Model
1.5 (0.16)	3000	200	50	2.13 (54)	P50B05005DXKSN	XSL-230-18
1.8 (0.2)	3000	200	60	1.65 (42)	P50B04006DXKSN	XSL-230-18
2.7 (0.3)	3000	200	100	2.13 (54)	P50B05010DXKSN	XSL-230-18
5.6 (0.63)	3000	200	200	2.99 (76)	P50B07020DXKSN	XSL-230-18
8.4 (0.95)	3000	200	300	2.99 (76)	P50B07030DXKSN	XSL-230-18
11.2 (1.27)	3000	200	400	2.99 (76)	P50B07040DXKSN	XSL-230-18
14 (1.58)	3000	200	500	3.39 (86)	P50B08050DXKSN	XSL-230-18
27 (3)	3000	200	750	3.39 (86)	P50B08075DXKSN	XSL-230-36
34.7 (3.92)	3000	200	1000	3.39 (86)	P50B08100DXKSN	XSL-230-36

P3 & P5 Options: D 200V, P or V 100V; X no Brake, C 24V Brake; ST no Key, SN Key. P5 Option: B Metric flange, N NEMA

**Dimensions**

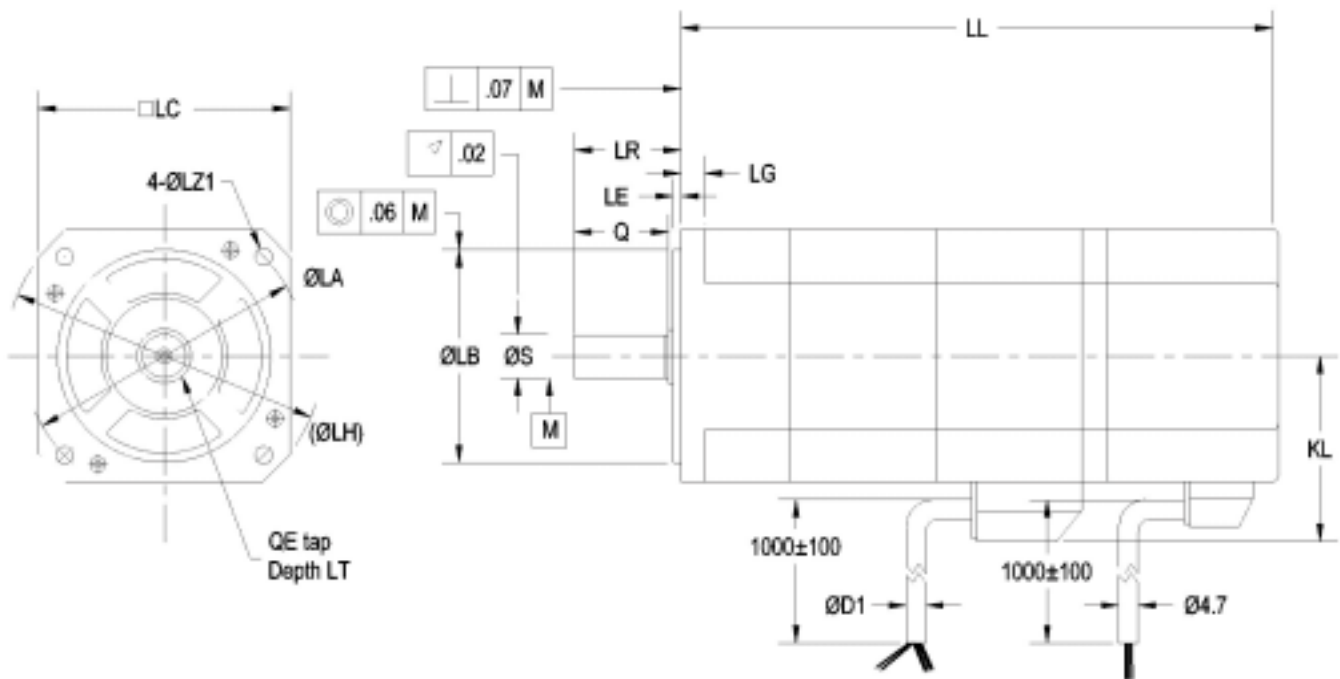

LC is Flange dimension.

**Xenus to P3 & P5  
WIRING**

