



[request information](#)

[R & D projects](#)

[photo gallery](#)

[employment opportunities](#)

[our facilities](#)

[partner companies](#)

ST-5
[stirling engines](#)

[very interesting links](#)

STIRLING TECHNOLOGY, INC.

Leading The Industry In Energy Recovery Ventilation Technology



Click [here](#) to learn how you can have a "healthy house!"

ST-5
STIRLING ENGINES



[our facilities](#)

[S.E.C. japan](#)

[request information](#)

[R & D projects](#)

ST-5 Stirling Engine
demonstration movie

Stirling Technology, Inc.
178 Mill St.
Athens, Ohio 45701

Email: info@stirling-tech.com

phone: (800) 535-3448
or: (740) 594-2277
fax: (740) 592-1499



Very Interesting Links:

[*Global Cooling B.V.*](#) *Stirling cycle coolers: The future of refrigeration.*

[*Global Cooling Manufacturing*](#) *A subsidiary of Global Cooling.*

[*http://rsd.gsfc.nasa.gov/goes/chesters.html*](http://rsd.gsfc.nasa.gov/goes/chesters.html) *The home page of Dennis Chesters. A Goddard Space Flight Center Scientist. This site will lead you to more places than you could ever have time for!*



[*Return to the Main Page*](#)

Email : stirltec@stirling-tech.com



Global Cooling

Innovators in Energy Conversion

home | about us | what we do | technology overview | technical papers | contact us



"Changing the Way the World Cools"



welcome to the homepage of Global Cooling!

We develop innovative refrigeration solutions. For example, the Free-Piston Stirling Cooler developed by Global Cooling has a high energy efficiency and uses earth friendly cooling substances. If you feel your refrigeration products are in need of major innovation, please contact us. Together we can change the way the world cools!



did you know...

John Ericsson, the inventor of marine screw propellers and gun turreted warships and the designer of the famous civil war era Monitor was also the inventor of the high performance wire mesh regenerator used in modern Stirling engines and cooling machines. Indeed, the largest Stirling engine ever constructed was designed by Ericsson for use in the ship of the same name Ericsson. Even more amazing is that he constructed the first solar driven Stirling engine using a parabolic reflector in

about 1870.

©2005 Global Cooling BV - Lagedijk 22, 5705 BZ Helmond - +31 492 450705 - info@globalcooling.nl



"Changing the Way the World Cools"

- [Home](#)

- [GC Japan](#)

- [Stirling History](#)

- [Stirling Links](#)

- [Contact Us](#)

- [Tech Overview](#)

- [What We Do](#)

- [How it Works](#)

- [Products](#)

- [Tech Papers](#)

- [Licensing](#)

about global cooling

Innovators in Energy Conservation

Global Cooling Inc. is a Delaware USA, based corporation with two, wholly owned subsidiaries; Global Cooling BV and Global Cooling Manufacturing. Global Cooling BV, with headquarters in The Netherlands, was brought into existence in 1994 when it purchased a license for free-piston Stirling refrigeration technology developed by Sunpower of Athens, Ohio. Global Cooling Manufacturing Co., with headquarters in Athens, Ohio, was established in 1997 for the purpose of developing and producing Stirling Coolers for Global Cooling B.V.



Global Cooling - The Netherlands

PROBLEM TO BE SOLVED

Stirling coolers will dramatically reduce the energy consumption and environmental impact of refrigeration. Despite the expectations and promises of current refrigerants, particularly the hydrofluorocarbons (HFC's) like R134a, it has been demonstrated that these refrigerants still have a detrimental affect on the environment. The Free Piston Stirling Cooler (FPSC) technology incorporated into products by Global Cooling and its licensees uses only natural working fluids (helium) and operates at high efficiencies, providing a fundamental advantage over competing systems.



Global Cooling - United States

THE GLOBAL COOLING ANSWER



Self Contained Low Temperature Petroleum Analyzer

Global Cooling's free-piston Stirling has several unique benefits over conventional refrigeration systems. While current domestic refrigerators have a Rankine-cycle cooling system, driven by a motor-compressor, in a Stirling refrigerator this system would be replaced by a Stirling-cycle cooling system. Rankine systems show a characteristic decrease in efficiency as the demand for cooling decreases, e.g. when the refrigerator is maintaining a cold condition. However, Free Piston Stirling Coolers (FPSC's) retain their high efficiency regardless of the demand for cooling because they can fully modulate their capacity to match the required load. In addition, the FPSC system requires no environmentally damaging CFC's, HCFC's, HFC's, or dangerous hydrocarbons (butane, for example). Operationally, the FPSC is able to work efficiently at far higher and far lower temperatures than conventional equipment, making it ideal for new or otherwise impractical cooling and heat transport problems.



Global Cooling - Japan

eENERGY/ENVIRONMENTAL/ECONOMIC BENEFITS

Global Cooling's FPSC, with its ability to fully modulate cooling capacity to match demand, is much more energy efficient than conventional Rankine systems which can only turn on and off. GCBV submitted a design for a

portable refrigerator to the judging committee of the Maltha Environmental Award in 1995 and was awarded First Prize. Today this concept has been commercialized in the form of a 25 liter consumer portable refrigerator/freezer manufactured by Twinbird Corporation of Japan.

NATIONAL/INTERNATIONAL IMPACTS:



25L Twinbird FPSC Portable refrigerator/Freezer

Global Cooling intends to commercialize its Stirling cooler globally by licensing the technology to major appliance manufacturers on a world wide basis. A number of major appliance manufacturers are currently sponsoring development work at Global Cooling. Several Global Cooling Stirling coolers are being tested at independent laboratories around the world.

©2005 Global Cooling BV - Lagedijk 22, 5705 BZ Helmond - +31 492 450705 - info@globalcooling.nl



"Changing the Way the World Cools"

- Home
- About GC
- GC Japan
- Stirling History
- Stirling Links
- Contact Us

- Tech Overview
-
- How it Works
- Products
- Tech Papers
- Licensing

what we do

Our Services - decision tree

We develop innovative refrigeration solutions. For example, the Free-Piston Stirling Cooler (FPSC) developed by Global Cooling has a high energy efficiency and uses earth friendly cooling substances. If you feel your refrigeration products are in need of major innovation, please contact us. Together we can change the way the world cools!

A Free Piston Stirling Cooler (FPSC) is a single phase cooling device that moves heat from a cool source to a warm sink with the help of external heat exchangers. Applications of FPSCs range from exotic deep temperature units to machines that perform well in domestic applications, such as home refrigerators.

A FPSC differs from a compressor system in that the refrigerant is not pumped into the space that is to be cooled. Rather, a Stirling cooler has a cold head, where heat is transferred into the machine, and a warm head, where heat is transferred out of the machine. External heat exchangers are used to transfer heat from the refrigerated space to the Stirling and are simply clamped onto the appropriate head. External heat exchangers are customized for the specific needs of each application, but typically come in the form of a thermosyphon, pumped fluid loop, or forced air and fin system.

Global Cooling's Free Piston Stirling Cooler (FPSC) technology is currently available in 40 and 100 Watt capacities. Soon, new FPSC coolers will become available in capacities up to 300Watts. The chart below outlines some of the current and soon to be released FPSC performance data.

Model *under development	Cooling Capacity (W)	Temperature Range (°C)	COP
TB40	40	-90 to +65	1.2
M100	100	-120 to +60	≈2
*	>100	200+	1.5+
*	200	-120 to +60	2+
*	300	-120 to +60	2+

We have created this decision tree to help you determine whether we provide the services that you desire.

Please Choose:

- [Energy Conversion](#)
- [Heat Transfer](#)

©2005 Global Cooling BV - Lagedijk 22, 5705 BZ Helmond - +31 492 450705 - info@globalcooling.nl



"Changing the Way the World Cools"

technology overview

Stirling coolers

- Home

- About GC

- GC Japan

- Stirling History

- Stirling Links

- Contact Us

- What We Do

- How it Works

- Products

- Tech Papers

- Licensing

What is a Stirling cooler?



A Free Piston Stirling Cooler (FPSC) is a single phase cooling device that moves heat from a cool source to a warm sink with the help of external heat exchangers. Applications of FPSCs range from exotic deep temperature units to machines that perform well in domestic applications, such as home refrigerators.

A FPSC differs from a compressor system in that the refrigerant is not pumped into the space that is to be cooled. Rather, a Stirling cooler has a cold head, where heat is transferred into the machine, and a warm head, where heat is transferred out of the machine. External heat exchangers are used to transfer heat from the refrigerated space to the Stirling and are simply clamped onto the appropriate head. External heat exchangers are customized for the specific needs of each application, but typically come in the form of a thermosyphon, pumped fluid loop, or forced air and fin system.

What are the advantages of FPSCs?

1. [Extremely long life is reached through the use of non-contact running surfaces.](#) **Gas bearings** allow the two moving parts to "ride on a cushion of air" keeping the running surfaces from making contact while the machine is operating.
2. [High efficiency over a wide refrigerated and ambient temperature range.](#) Unlike vapor compression systems outfitted with capillary tubes that have optimized performance at only one temperature condition, Stirling coolers maintain their high performance over a wide range of temperature conditions.
3. [No CFC or other environmentally dubious chemicals.](#) Global Cooling uses the environmentally safe, inert gas helium as the working fluid in their Stirling coolers.
4. [Light weight machines.](#) Light weight makes portable cooling a reality.
5. Infinitely variable lift leads to no "on/off" losses. The Stirling cooler can be modulated to provide cooling between 0% and 100% of the capacity. Modulating the cooler allows for precision cooling of the refrigerated space and removes the losses associated with "on/off" controlling, an energy saving or extension of battery life of approximately 20%. The coolers also have very low start current, being able to start with just a minimum input. No need for starting capacitors or expensive electronics.
6. Operation at high ambient temperatures. Stirling coolers perform well in harsh temperature environments, high ambient temperatures are limited only by the materials of the cooler.

Gas Bearing Technology

The Stirling coolers designed at Global Cooling utilize oil-free lubrication by the way of gas bearings. Gas bearings work by charging an internal volume in the piston during the compression stroke and then leaking the trapped gas out into the space between the piston and the cylinder wall. This produces a layer of high pressure gas between the two running surfaces that levitates the piston allowing the piston and cylinder to operate in a non-contact way. As long as the gas bearings are working properly and the machine is running, the moving parts will never make contact and last for an extremely long time.

Light Weight Coolers

Stirling coolers excel in small capacity cooling and have light weight making it the perfect solution for portable cooling. A 40 Watt Stirling cooler weighs 1.6 kg where a similarly sized compressor weighs 4.3 kg. A plot of the mass vs. capacity for both compressors and Stirling machines is shown below. There are two Stirling trend lines, the solid line indicates the mass and capacity of prototype or limited production machines today, where the dashed line represents the projected performance and mass after becoming fully commercialized.

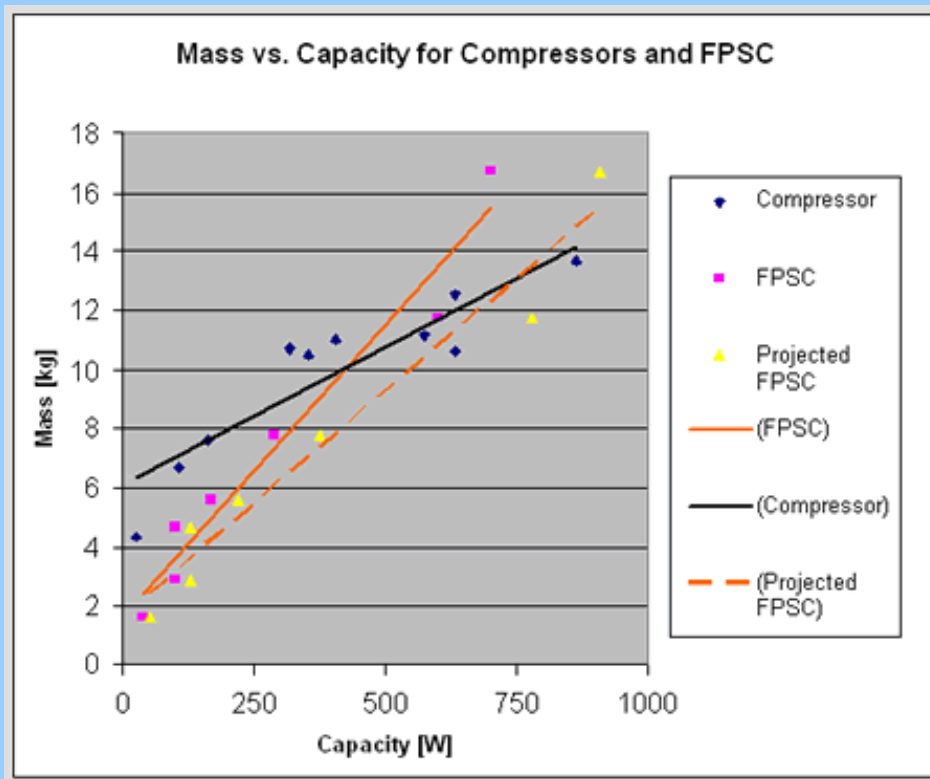

Performance Map of Stirling Cooler

Stirling coolers have high performance over a wide temperature range, making them ideally suited for applications with varying ambient or refrigerated space temperatures, such as outdoor vending machines or portable cool boxes. A performance map is shown below for the M100A optimized for near room temperature use.

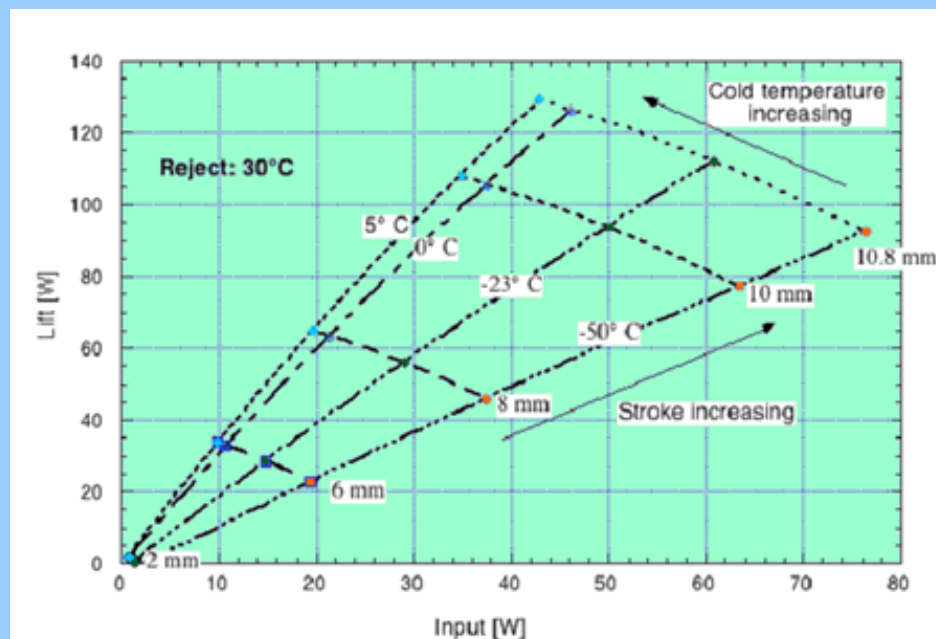

Figure 1: Performance map of M100A with a fixed reject temperature of 30°C and a cold head temperature range between 5°C and -50°C.

Environmentally Responsible Cooling

Currently, the majority of the world's cooling needs are being met by a vapor compression cycle that uses a compressor to circulate an artificial (typically) working fluid. These artificial working fluids, called refrigerants, typically hydro-fluorocarbons (HFCs) or hydro-chlorofluorocarbons (HCFCs such as R22), have been proven to have excellent thermal properties, remain stable when properly bottled, and are inexpensive to manufacture. Unfortunately, they are also harmful to the global environment by being major contributors to the depletion of the ozone layer and contributors to the global warming phenomena.

In 1987, negotiators ratified the Montreal Protocol to create binding commitments to reduce the manufacture and use of environmentally dubious chemicals harmful to the ozone layer. As of 2002, 183 countries have pledged to phase out the use of ozone depleting substances, including chlorofluorocarbons (CFCs), and hydro-chlorofluorocarbons (HCFCs). Developed countries that signed the Montreal Protocol fully phased out CFCs in 1996, and instituted a production freeze on HCFCs in 1996. By 2010, all CFC's and the majority of HCFCs will no longer be in use.

Replacements for the phased out refrigerants have been developed; hydro-fluorocarbons (HFCs such as R-134a), and hydro-carbons (HCs such as butane) are the current options for refrigerants, however, both have their downfalls. HFCs do not have an ozone depleting nature, but do contribute to the global warming problem. Researchers have shown that once released into the environment, the most common HFC, R-134a, will contribute to the global warming problem for up to 100 years before it is finally broken down. HFs such as butane have the downfall of being explosive, causing a serious risk when used in indoor applications.

Refrigerant	Ozone Depletion	Global Warming	Safe
CFC	Very High	Very High	Y
HCFC	Very High	Very High	Y
HFC	Zero	High	Y
HF	Zero	Zero	N

Figure 1: Chart of the environmental impact of different refrigerants.

Stirling coolers are a technology available today that has zero effect on the ozone layer, does not directly contribute to global warming, and does not use a flammable gas. Stirling coolers are able to avoid all of the downfalls of the chemicals used in vapor compression cycle by using Helium as the working fluid. Helium has the advantage of being a natural, non-flammable, inert gas that is not reactive to the world around it.



"Changing the Way the World Cools"

- [Home](#)

- [About GC](#)

- [GC Japan](#)

- [Stirling History](#)

- [Stirling Links](#)

- [Contact Us](#)

- [Tech Overview](#)

- [What We Do](#)

- [How it Works](#)

- [Products](#)

- [Licensing](#)

technical papers

Papers in PDF Format: Adobe Acrobat Reader is required to view these files.

Note: All Papers have been formatted for printing on 8.5 X 11 inch paper.

<i>Title</i>	<i>Author(s)</i>
"Operational characteristics of Stirling machinery"	Y.-R. Kwon and D.M. Berchowitz
"Measurement and application of performance characteristics of a Free-Piston Stirling Cooler"	M. Janssen and P. Beks
"Experimental investigation of a Stirling cycle cooled domestic refrigerator"	E. Oguz and F. Ozkadi
"An electrical actuated reed valve for use as a pulse width modulated expansion valve"	R. Redlich, D.E. Kiiikka and D.M. Berchowitz
"Energy efficient freezer installation using natural working fluids and a free piston Stirling cooler"	S.C. Welty and F. Cueva
"Design and testing of a 40W free-piston Stirling cycle cooling unit"	D.M. Berchowitz, J. McEntee and S. Welty
"Maximized performance of Stirling-cycle refrigerators"	D.M. Berchowitz
"Experimental evaluation of a solar pv refrigerator with thermoelectric, Stirling and vapor compression heat pumps"	Michael K. Ewert, <i>et al</i>
"The application of Stirling cooler to refrigeration"	S.-Y. Kim, <i>et al</i>
"Recent advances in Stirling cycle refrigeration"	D.M. Berchowitz, D. Kiiikka and B.D. Mennink
"Stirling coolers for solar refrigerators"	D.M. Berchowitz
"Development of an improved Stirling cooler for vacuum super insulated fridges with thermal store and photovoltaic power source for industrialized and developing countries"	B.D. Mennink and D.M. Berchowitz
"Low cost small cryocoolers for commercial applications"	A. Karandikar and D. Berchowitz
"Free piston Rankine compression and Stirling cycle machines for domestic refrigeration"	D.M. Berchowitz
"Stirling refrigerators for Space Shuttle Experiments"	K. McDonald, D. Berchowitz, J. Rosenfeld and J. Lindemuth
"Estimated size and performance of a natural gas fired duplex Stirling for domestic refrigeration applications"	D.M. Berchowitz and J. Shonder
"An Experimental Study on the Refrigeration Capacity and Thermal Performance of Free Piston Stirling Coolers"	Emre Oguz and Fatih Ozkadi
Miniature Stirling Coolers	D.M. Berchowitz

©2005 Global Cooling BV - Lagedijk 22, 5705 BZ Helmond - +31 492 450705 - info@globalcooling.nl



"Changing the Way the World Cools"

Contact Information

contact us

Global Cooling, B.V.

Director:
Kerst Toxopeus
Lagedijk 22
5705 BZ Helmond
Phone: +31 492 450705

Global Cooling, US

94 North Columbus Rd.
Athens, Ohio 45701 USA
Phone: (740) 592-2655
email: info@globalcooling.com
www.globalcooling.com

Global Cooling, Japan

Nobutoshi Tezuka, President
Kanagawa Science Park
East Tower 213
3-2-1, Sakado, Takatsu-ku
Kawasaki-City, Japan
Phone: +81-44-833-3233
Fax: +81-44-833-3692
e-mail: ftezuka@aol.com
www.globalcoolingjapan.com

Please use this form to send an email to Global Cooling. We will respond as soon as we are able.

* Indicates a required field.

* Name:

* E-mail Address:

Company Name:

Address:

City:

State / Providence:

Zip or Postal Code:

Country:

Phone Number:

Reason for Inquiry:

Message:



"Changing the Way the World Cools"

- Home

- About GC

- Stirling History

- Stirling Links

- Contact Us

- Tech Overview

- What We Do

- How It Works

- Products

- Tech Papers

- Licensing

Global Cooling Japan

Global Cooling Japan is a licensee of GCM and is manufacturing and selling GGM EEV technology, under the brand name Eco Valve.



Global Cooling Japan

Nobutoshi Tezuka, President
 Kanagawa Science Park
 East Tower 213
 3-2-1, Sakado, Takatsu-ku
 Kawasaki-City, Japan
 Phone: +81-44-833-3233
 Fax: +81-44-833-3692
www.globalcoolingjapan.com

ECOVALVE ELECTRONIC EXPANSION VALVE

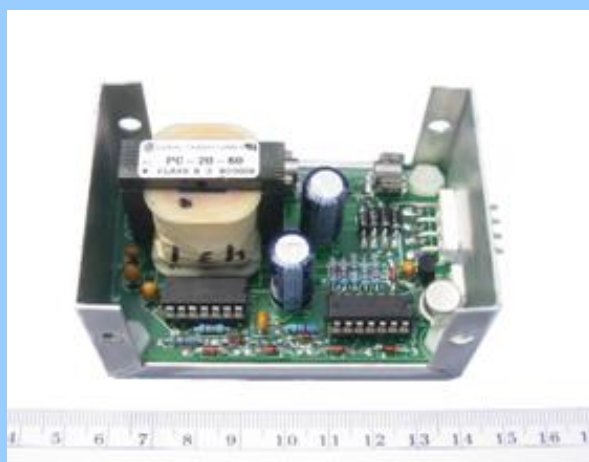

Unique capabilities:

- Control of refrigerant flow down to exceptionally low rates of 15 W or less of refrigeration. A range of presently

available orifice diameters enables flow control to 1200 W refrigeration, and higher flow rates are possible with a larger valve body.

- Maintains stable superheat of 3°C, even at low flow rates.
- Physically small and easy to install by brazing into the liquid line at the evaporator inlet. The control unit is small, easily installed, and uses only 0.5W average power.
- Works with all common refrigerants, e.g., R134a, R22, R407C, isobutane, etc. Can be adapted for CO2.
- Very low leakage reduces stop-start loss and minimum controllable flow.
- Ecovalve has been subjected to rigorous accelerated life tests, and showed no deterioration at the end of the equivalent of 15 years of service life.
- Digital control with an inexpensive microprocessor

Ecovalve operates on the pulsed-flow principle. An electrically actuated reed valve* is pulsed open at two second intervals. Flow rate is proportional to the fraction of the pulse interval during which the reed valve is open. That fraction is controlled by superheat as measured by thermistors. Stabilization of superheat is achieved with an inexpensive, passive, “superheat stabilizer”**, which performs the function of an expensive PID control and is, in its simplest form, a section of tubing typically 20 mm Diameter x 200 mm length, in the suction line preceding the thermistor that measures vapor temperature.

ECOVALVE Installation

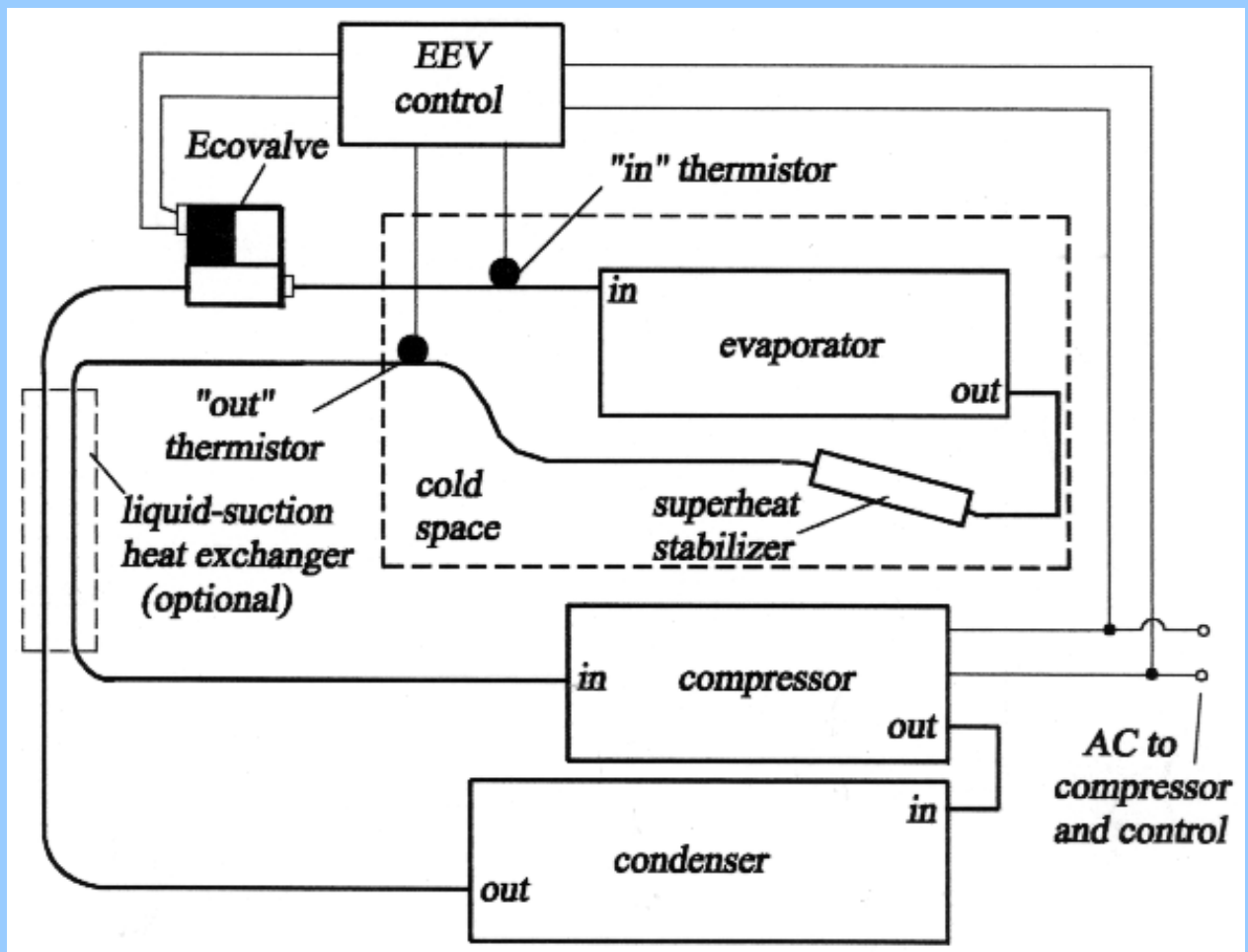

Ecovalve is supplied with a thermistor wiring harness terminated with resistance-matched thermistors and a connector that plugs into the control. Connectors for the EEV actuator coil and for AC power to the control are also supplied. If DC power for the control is available from existing supplies, a control without AC-DC power conversion is available at lower cost.

Specifications

Flow rate range is determined by orifice diameter, maximum duty cycle (duty cycle is defined as the ratio of valve-open time to pulse repetition interval), and minimum duty cycle. Minimum duty cycle is necessary to restart superheat control after prolonged compressor-off during which the evaporator reaches temperature equilibrium. Max. and min. duty cycles are hard-wired into the control according to customer requirements.

Orifice Diameter (mm.)	Max Duty cycle	Min Duty Cycle	Typical R134a Refrigeration Range (Watts)
0.63	0.90	0.22	146 - 600
0.63	0.67	0.13	87 - 446
0.63	0.43	0.08	53 - 287

For larger or smaller orifice diameters, refrigeration range can be approximated by:

$$\text{Range with orifice Diameter } D \text{ (mm.)} = (D/0.63)^3 \times (\text{range with } 0.63 \text{ mm. orifice})$$

Orifice diameter will be supplied according to customer requirements.

Superheat set-point is $3.5^{\circ}\text{C} \pm 1^{\circ}\text{C}$ at midrange refrigeration and is hard wired into the control. Superheat varies with duty cycle by approximately

$\pm 2^{\circ}\text{C}$, over the range of temperatures common in refrigeration.

* U.S. Patent 5,967,488. Other Patents pending

** U.S. Patent 6,260,368. Other patents pending

Commercial Endorsment, December 2005:

The Coca-Cola Company, based on laboratory and field tests, endorses Global Cooling's expansion valve (sold as the "Ecovalve") as an option that can improve energy efficiency, increase the cooling capacity and lower initial pull-down time across a broad range of ambient operating temperatures of sales and marketing equipment. The installation of the Ecovalve is an effective tool to improve the environmental impact of new and refurbished sales and marketing equipment. A technical fact sheet is available on request or at www.globalcooling.com.

Please note that equipment that has been redesigned to include the Ecovalve would need to be submitted for re-certification to confirm performance and efficiency prior to our system's inclusion of the valve in its purchase plans.



"Changing the Way the World Cools"

- Home

- About GC

- GC Japan

- Stirling Links

- Contact Us

- Tech Overview

- What We Do

- How it Works

- Products

- Tech Papers

- Licensing

Stirling History

Stirling machines Background

(Excerpt)

In the early 1970's, the uncertainty of energy costs and supplies and the increasing awareness of pollution made it important to investigate alternative prime movers. Major requirements for these devices are that they be efficient, non-polluting, reliable, economical and socially acceptable. The development and utilization of such systems may be of huge consequence. Widespread use of efficient prime movers are likely to have a considerable effect on the balance of payments for countries that import significant energy supplies.

However, aside from occasional price spikes, fuel costs have generally been low since the 1980s (particularly for the major industrial nations) and the pressure to find alternate low cost energy efficient prime movers has been to a large degree relegated to secondary considerations. The low cost of fuel has unfortunately hastened the problems of global pollution. The accumulation of CO₂ in the atmosphere is expected to produce a green house effect by insulating the earth and thus increasing the mean global temperatures. This, in turn, could eventually result in cataclysmic weather changes and even the melting of the polar ice caps. Another serious problem facing humanity in the near term is the accumulation of chlorofluorocarbons (CFCs) in the upper atmosphere. These compounds are broken down by ultraviolet light into highly reactive compounds that eventually consume vast quantities of the protective ozone layer. Prompt action by the industrial nations has led to the phasing out of the most dangerous of these compounds and future treaties are expected to further curtail CFC and hydrochlorofluorocarbons (HCFCs) production. CFCs and HCFCs are the compounds of choice in refrigeration and air conditioning and other applications of heat pumping. More recently even the latest alternative hydrofluorocarbon (HFC) refrigerants have been found to be formidable global warming agents and are now under scrutiny for potential banning.

The Stirling cycle machine, which can operate as either an engine or a heat pump, has aroused much interest because of its many favorable characteristics. These include:



- Minimal pollution. In the case of an engine, the exhaust gases are comparatively clean and cool.
- Silent and practically vibrationless operation in some configurations.
- Potential for low fuel or energy consumption. The maximum attainable efficiency or COP for any heat engine operating between the same temperature differential.
- Multi-fuel capability. The energy source may be almost of any form whatever, so long as it is available at a sufficiently high temperature. Stirling engines have been run on solar energy and a variety of liquid and solid fuels. This applies to heat pumping as well by the use of the duplex configuration.
- In many instances, it is possible to hermetically seal the machine thus eliminating problems arising from dirt ingress. Some of these configurations have demonstrated operating lives exceeding 10 years.
- Reversible operation allowing the same device to be used as an environmentally friendly wide temperature range refrigerator or heat pump. This feature also introduces the possibilities of

regenerative braking.

- Reasonable specific power (currently between 0.067 kW(e)/kg for higher power engines down to 0.033 kW(e)/kg for lower power engines). As a low capacity heat pump (up to a few hundred Watts), the specific lift is considerably better than other heat pump technologies (30 to 40 W/kg).
- Favorable torque characteristics for transportation applications. This leads to simpler transmission designs.
- Mechanical simplicity. In some configurations gas bearings are easily implemented thus avoiding the need for oil lubrication.

To view the full GC History document, click [here](#).

©2005 Global Cooling BV - Lagedijk 22, 5705 BZ Helmond - +31 492 450705 - info@globalcooling.nl



"Changing the Way the World Cools"

- Home

- About GC

- GC Japan

- Stirling History

- Contact Us

- Tech Overview

- What We Do

- How it Works

- Products

- Tech Papers

- Licensing

links

companies using Stirling technology

Company	link
AvXcel Manufactures of TropiKool Marine Refrigeration Products	www.avxcel.com
Coleman Coleman® Stirling Power Cooler & RoadTrip™ Sport Combo	www.coleman.com
Prosa Software email: Bernd Thomas	website
Stirling Machine World	www.stirmach.com
Sunpower	www.sunpower.com
Twinbird	http://fpsc.twinbird.jp





"Changing the Way the World Cools"

- Home

- About GC

- GC Japan

- Stirling History

- Stirling Links

- Contact Us

- Tech Overview

- What We Do

- Products

- Tech Papers

- Licensing

how it works

Stirling Free Piston Stirling Cooler

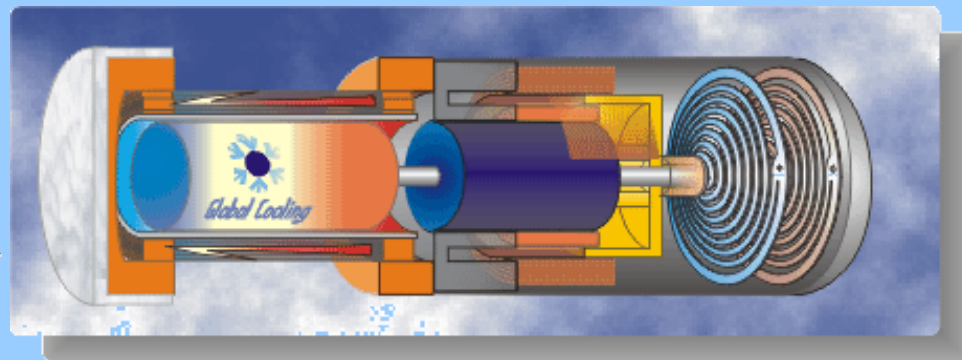

Figure 1 :FPSC Animation

The Free Piston Stirling Cooler (FPSC) is a device which makes use of the stirling cycle and a moving magnet linear motor for cooling applications. The stirling cycle belongs to a class of thermodynamic cycles that yield the highest conversion efficiency between mechanical and thermal energy.

The animation above shows how the machine works and the image below defines the components necessary to understand its operation. The stirling cycle is a reversible cycle which means that heat can be put into the machine and electric power will be produced or electric power can be put in and heat will be removed. The case of interest to us at Global Cooling is the latter of the two, the Free Piston Stirling Cooler.

FPSC DYNAMICS

The FPSC cycle starts with an AC input into the linear motor. This input drives a magnet ring which is rigidly attached to the piston (hence the term, moving magnet motor). The piston is the dark blue oscillating cylinder in the animation. The white oscillating cylinder is referred to as the displacer. The difference between the displacer and the piston is that the piston has two different pressures on either of its faces whereas the pressure on either end of the displacer is the same (assuming the pressure drop through the passages between the two

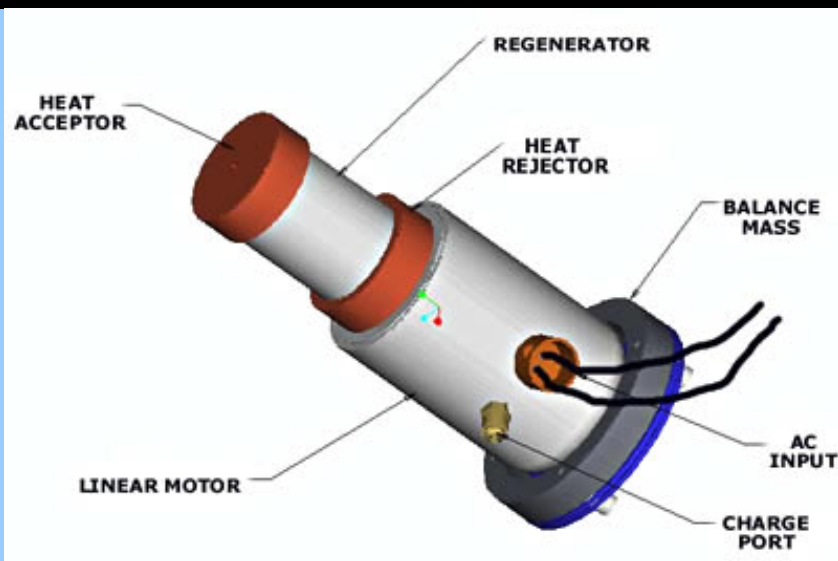

Figure 2 : Model M100B Image showing basic components of a FPSC.

faces is negligible). This means that the pink gas in the animation cannot flow back to the other side of the piston but the blue (cold) gas on one side of the displacer is free to flow back to the pink (hot) gas face of the displacer. The piston is driven by the linear motor since it is rigidly attached to the moving magnet ring. The displacer is driven by the force which arises because of the difference in areas of its two faces.

$$F = P_{amp} \cdot A_{disp} - P_{amp} \cdot (A_{disp} - A_{rod})$$

$$F = -P_{amp} \cdot A_{rod}$$

The pressure amplitude (P_{amp}) is the amplitude of the pressure wave . This is not the same as the overall pressure of the machine. The FPSC is hermetically sealed and is typically pressurized 20 to 30 times atmospheric pressure. The charge port shown in figure 2 is where the helium (working fluid) is introduced into the machine.

The absorber mass shown in figure 2 is a mass spring system that balances the machine. It is not shown in the animation but when the displacer and piston oscillate within the machine, the casing also oscillates. In order to mount it more easily without the transmission of vibration to a base, the absorber mass "absorbs" the vibration.

FPSC THERMODYNAMICS

Once the dynamics have started in a stirling cooler a very simple thermodynamic cycle ensues. To help in understanding the thermodynamics it is useful to look at a Pressure-Volume diagram. The ideal case will be as shown in figure 3.

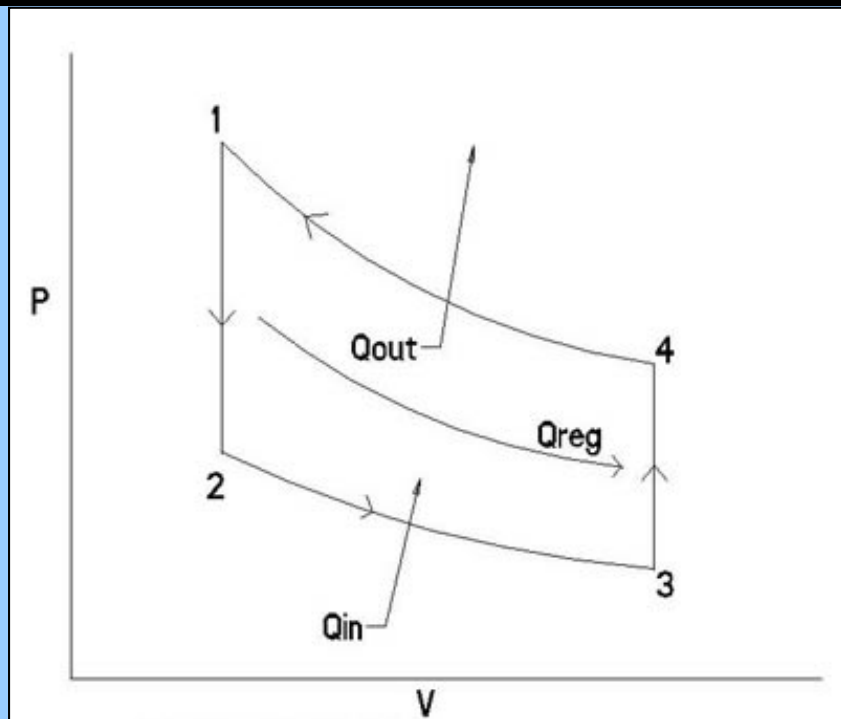

Figure 3 : Ideal Stirling Cycle Pressure-Volume Diagram

The ideal stirling cycle is made up of four totally reversible processes:

- 1-2 Constant volume regeneration (internal heat transfer from the working fluid to regenerator)
- 2-3 Constant temperature expansion (heat addition from external source)
- 3-4 Constant volume regeneration (internal heat transfer from regenerator back to the working fluid).
- 4-1 Constant temperature compression (heat rejection to external sink)

The actual stirling cycle has many losses associated with it and does not really involve isothermal processes so it is not totally reversible. Since the FPSC involves sinusoidal motion the edges of the p-v diagram are not sharp edges as indicated in the ideal diagram in figure 3. The actual p-v diagram ends up looking more like an oval with the sharp edges of the ideal diagram rounded off. However, the ideal diagram is useful for beginning to understand the cycle.

A simple second order analysis of the stirling cycle has been developed by Gustav Schmidt in 1871. The analysis has been used widely as an approximation of stirling performance. David Berchowitz and Israel Urieli give a complete description of it in their book [Stirling Cycle Engine Analysis](#).

[Download](#) the description of the Schmidt Analysis from the book.

COPYRIGHT AND TRADEMARK NOTICES

All contents of this Web site are Copyright of Global Cooling BV, and/or its suppliers. All rights reserved. Visitor may not modify, copy, distribute, reproduce, publish, license, create derivative works from, transfer, or sell any information, software, products or services obtained from this Web site. Products and company names mentioned herein are the trademarks of their respective owners.



"Changing the Way the World Cools"

- Home

- About GC

- GC Japan

- Stirling History

- Stirling Links

- Contact Us

- Tech Overview

- What We Do

- How it Works

- Tech Papers

- Licensing

GCM products

M-100 Free Piston Stirling Cooler (FPSC)

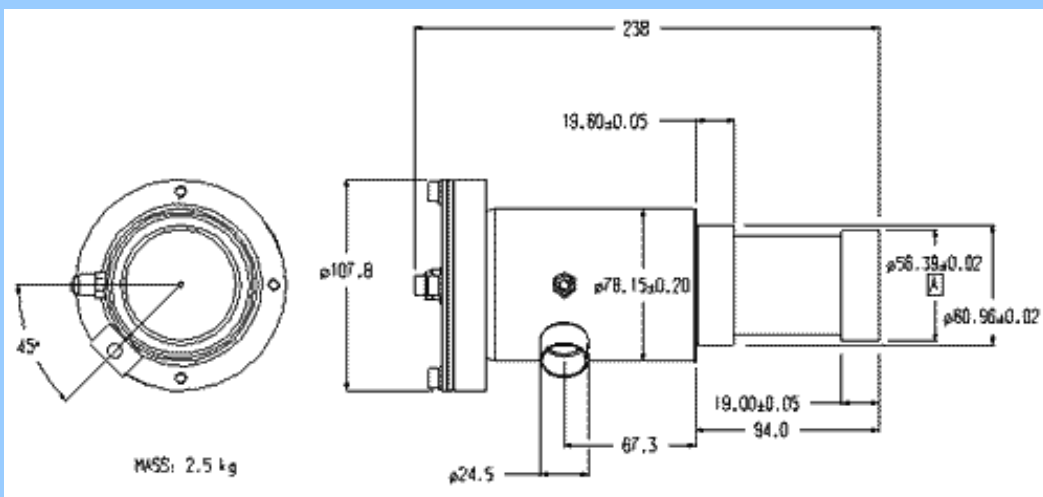

M100B Exterior Dimensions [mm]

The M100B Free Piston Stirling Cooler (FPSC) is among the first Stirling coolers to be introduced to the market. The first production run of this unit allowed Global Cooling (GC) to introduce its technology to a number of manufacturers working in industries from food refrigeration to laser cooling. Not only did the first production runs allow GC to sell demonstrators to interested parties, it also gave GC a chance to field test units in a number of different environments. The feedback and reliability information that we received from these first units allowed us to continually improve the product as development progressed



We are also involved with other manufacturers to develop models of different capacities and of lower cost. Some of these are already available while others are projected to be available to the public in one year. For information on the progress of these programs check this web site since it will be kept up to date.

To investigate the possibilities of using Stirling Coolers in your application you can find detailed information throughout this web site. Check the [Technical Papers](#) page for papers on the subject.

- [M100B HTML Brochure](#)

- [M100B PDF Brochure](#)

- [Popular Science Article](#)

ECOVALVE ELECTRONIC EXPANSION VALVE



Unique capabilities:

- Control of refrigerant flow down to exceptionally low rates of 15 W or less of refrigeration. A range of presently available orifice diameters enables flow control to 1200 W refrigeration, and higher flow rates are possible with a larger valve body.
- Maintains stable superheat of 3°C, even at low flow rates.
- Physically small and easy to install by brazing into the liquid line at the evaporator inlet. The control unit is small, easily installed, and uses only 0.5W average power.
- Works with all common refrigerants, e.g., R134a, R22, R407C, isobutane, etc. Can be adapted for CO₂.
- Very low leakage reduces stop-start loss and minimum controllable flow.
- Ecovalve has been subjected to rigorous accelerated life tests, and showed no deterioration at the end of the equivalent of 15 years of service life.
- Digital control with an inexpensive microprocessor

Ecovalve operates on the pulsed-flow principle. An electrically actuated reed valve is pulsed open at two second intervals. Flow rate is proportional to the fraction of the pulse interval during which the reed valve is open. That fraction is controlled by superheat as measured by thermistors. Stabilization of superheat is achieved with an inexpensive, passive, "superheat stabilizer", which performs the function of an expensive PID control and is, in its simplest form, a section of tubing typically 20 mm Diameter x 200 mm length, in the suction line preceding the thermistor that measures vapor temperature.

"The Coca-Cola Company, based on laboratory and field tests, endorses Global Cooling's expansion valve (sold as the "Ecovalve") as an option that can improve energy efficiency, increase the cooling capacity and lower initial pull-down time across a broad range of ambient operating temperatures of sales and marketing equipment. The installation of the Ecovalve is an effective tool to improve the environmental impact of new and refurbished sales and marketing equipment. A technical fact sheet is available on request or at www.globalcooling.com.

Please note that equipment that has been redesigned to include the Ecovalve would need to be submitted for re-certification to confirm performance and efficiency prior to our system's inclusion of the valve in its purchase plans."

Note: GC does not offer consumer sales. If you are interested in low cost commercial or consumer FPSC products please see:

<i>Company</i>	<i>URL</i>
AvXcel Manufactures of TropiKool Marine Refrigeration Products	www.avxcel.com
Coleman Coleman® Stirling Power Cooler & RoadTrip™ Sport Combo	www.coleman.com
Twinbird	www.twinbird.jp



"Changing the Way the World Cools"

- Home

- About GC

- GC Japan

- Stirling History

- Stirling Links

- Contact Us

licensing

Part of GC's business model is licensing of core technologies. At this time the FPSC technology is being developed by Global Coolings's manufacturing partners. The Electrically Actuated Reed Valve (EEV) is being manufactured and sold by our partner and affiliate [Global Cooling-Japan](#) as the EcoValve.

- Tech Overview

- What We Do

- How it Works

- Products

- Tech Papers

-



"Changing the Way the World Cools"

• [Home](#)

• [About GC](#)

• [GC Japan](#)

• [Stirling History](#)

• [Stirling Links](#)

• [Contact Us](#)

what we do

Our Services - Energy conversion

Please Choose the type of **energy conversion** application:

- [Heating](#)

- [Cooling](#)

- [Power](#)

• [Tech Overview](#)

•

• [How it Works](#)

• [Products](#)

• [Tech Papers](#)

• [Licensing](#)



"Changing the Way the World Cools"

• Home

• About GC

• GC Japan

• Stirling History

• Stirling Links

• Contact Us

what we do

Our Services

Heat Transfer

Heat Exchanger Design - [Contact Global Cooling](#)

- Plastic HX
- Conventional
- Optimization

Two-phase Thermosiphon - [Contact Global Cooling](#)

- Isothermal (Heat moving over distance)

• Tech Overview

•

• How it Works

• Products

• Tech Papers

• Licensing

OPERATIONAL CHARACTERISTICS OF STIRLING MACHINERY

YONG-RAK KWON, DAVID M BERCHOWITZ

Global Cooling BV, Ijsselburcht 3,
6825 BS Arnhem, The Netherlands

Tel: 31-(0) 26-3653431, Fax: 31-(0) 26-3653549, E-mail: info@globalcooling.com

ABSTRACT

Alternative cooling technology using the Stirling cycle has been considered for application in domestic and commercial refrigeration by virtue of environmental friendliness and low energy consumption. However, the general features of the Stirling cooling system are not familiar to the refrigeration industry. Recently Stirling cooling machinery in the form of the free-piston Stirling cooler (FPSC) has reached an advanced stage of development. These units are expected to find use in applications such as freezers, refrigerators, portable cool boxes, and some commercial applications. A commercially available FPSC for small capacity applications (40 Watts class at ASHRAE conditions) is discussed as an example of the technology. Operational characteristics of the FPSC and Stirling cooling systems in general are presented. Particular focus is placed on applications requiring temperatures above -120°C . The modulation of cooling capacity is by stroke control and is in response to a temperature signal. A typical performance map showing COP and cooling capacity for given temperatures and drive voltage is presented. Such maps are a convenient means to determine the performance of a FPSC for a given application. Integration of the FPSC and heat transport to and from the FPSC are central issues for a complete system and strongly affects the overall performance.

INTRODUCTION

Domestic refrigeration using Stirling machinery was first studied by Finkelstein and Polonski (1959). Recently a number of workers have returned to the investigation of this technology. For example, Oguz and Ozkadi (2002) installed a FPSC and thermosiphon for heat transport in a 250 l prototype refrigerator. Comparisons between Rankine compressors and FPSCs have also been presented by Berchowitz (1998), Janssen and Beks (2002). In the latter paper, a highly efficient variable speed compressor (187 W) and a FPSC (100 W) were simulated in a domestic upright freezer (360 l). The Stirling system was shown to work relatively better at high ambient temperature (tropical condition) as well as at low heat load conditions as may be expected from low ambient temperature and better insulation. Practical product designs for FPSCs have also been presented. For example, the design and development of a portable cool box was discussed by Berchowitz *et al* (1999).

As presented in previous work, Stirling cooling system development needs to be approached differently than traditional Rankine refrigeration on a number of issues. For instance, ambient temperature variation does not affect the operation of the Stirling cooler except for changing heat load to the cooling system and the variation of COP due to the Carnot effect. Temperature span is therefore a more practical parameter for Stirling cooling systems for the estimation of overall performance. Starting current does not vary with ambient temperature and is always very low. These characteristics enable the Stirling cooling system to run over wide ambient conditions such as sub-tropical, tropical, and super-tropical temperatures. Continuous operation eliminates cyclic loss at low heat load applications (e.g. portable cool box) and the continuous capacity modulation characteristic reduces cold storage temperature variation. Furthermore, low mass and compact size allow location and handling flexibility. On the other hand, pull-down speed is relatively low compared to the on-off operation of Rankine systems. Rankine compressors are sized to approximately 200-250% of heat load while FPSCs are selected to have only 150-200% of heat load.

This paper discusses the general characteristics of FPSC that are needed for evaluation of the cooling system design. Two examples, namely a portable cool box and a biological storage application are presented to illustrate methodology and procedure. Special emphasis is placed on the use of the FPSC performance map. In this case, a 40 W FPSC unit is investigated. This unit is designed for low cost and easy manufacture for application to portable cooling systems. For the deeper temperature applications, a 100 W unit is considered.

1 CHARACTERISTICS OF FPSC

1.1 Temperature Span and Performance Map

A FPSC works over a very wide temperature range for the warm and cold sections provided that the physical properties of the components are maintained within the designed allowance. Warm head temperature (T_w), which depends on heat rejecter configuration and ambient temperature, can vary from low storage temperatures to an upper limit of between 65°C to a maximum of about 120°C where the magnets of the linear motor may be affected. Cold head temperature (T_c) may vary from typical refrigerator temperatures down to -120°C. For FPSCs built specifically to achieve low temperatures, the cold head may easily approach within a few tens of degrees of absolute zero. In other words, ambient and desired cold temperatures do not affect FPSC operation in the same manner as is the case with Rankine compressors. Temperature span (ΔT_s) defined by the difference between warm and cold head temperature is a more useful parameter for FPSC performance and cooling system performance estimation.

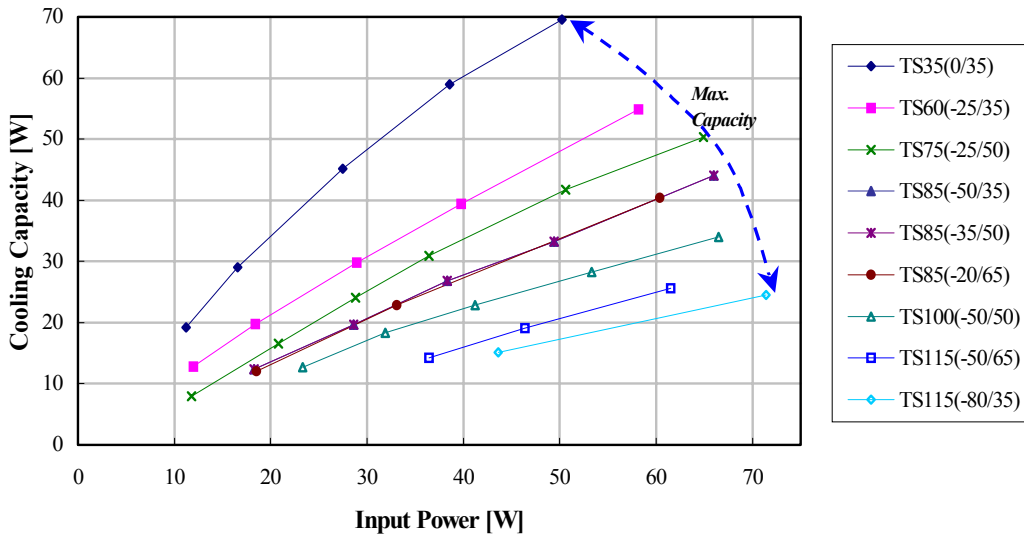

Figure 1. Performance map of 40 W FPSC with different temperature spans (Note: TS $\equiv \Delta T_s$).

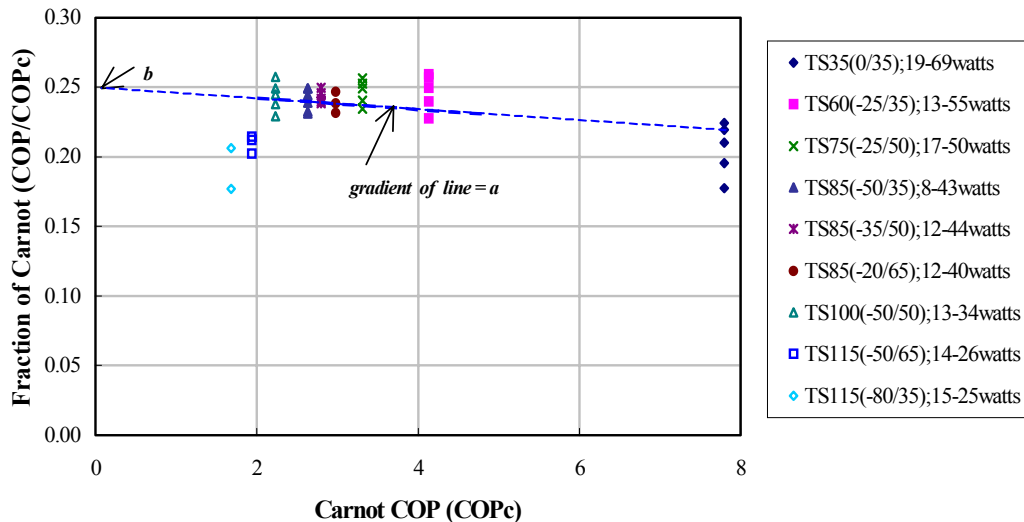

Figure 2. Fraction of Carnot vs. Carnot COP for 40 W FPSC (Note: TS $\equiv \Delta T_s$).

Fig. 1 shows the performance map of a 40 W FPSC taken from a set of data points. ΔT_s changes between 35°C and 115°C with a T_c variation of 0°C to -80°C and a T_w variation of 35°C to 65°C. Depending on the system design, this range could cover sub-tropical, tropical, and super-tropical conditions. Maximum cooling capacity at $\Delta T_s = 115^\circ\text{C}$ is decreased by 35% compared to $\Delta T_s = 35^\circ\text{C}$. The gradient of the data line is COP. COP and maximum cooling capacity at $\Delta T_s = 85^\circ\text{C}$ using three different T_w and T_c coincide in a line. This means that these conditions can cover sub-tropical, tropical, and super-tropical conditions and this unit may be used for refrigerator, freezer, or deep freezer. This characteristic is maintained until Carnot COP ($\text{COP}_C = (273 + T_c) / \Delta T_s$) approaches a relatively small number, for instance 2.0. This is a unique characteristic of the FPSC against the Rankine system.

Fig. 2 shows fraction of COP versus Carnot COP. This graph is a very typical COP map of FPSC as may be seen in Berchowitz (1998) and is valid for the full range of cooling capacity. The 100 W FPSC described by Berchowitz showed the same map shape but with different constants a and b . The constants a and b are dependent on the design of the unit itself. A generalized equation for COP may be generated as follows.

$$\begin{aligned} \text{COP}_{\text{FPSC}} / \text{COP}_c &= a \cdot \text{COP}_c + b \\ \text{COP}_{\text{FPSC}} &= a \cdot \text{COP}_c^2 + b \cdot \text{COP}_c \\ &= a \left(\frac{273 + T_c}{\Delta T_s} \right)^2 + b \left(\frac{273 + T_c}{\Delta T_s} \right) \end{aligned} \quad (1)$$

ΔT_s has a much stronger effect on Equation (1) than T_c in numerator because T_c varies between -50°C to 0°C and ΔT_s varies between 30°C to 70°C for many domestic, portable, and commercial cooling applications. Constants in Equation (1) may be obtained from Fig. 2 ($a = -0.0042$, $b = 0.25$), for use in the cooling system performance estimation.

1.2 Temperature and Cooling Capacity Modulation

Cooling capacity of a FPSC is proportional to the square of the piston amplitude. The piston is directly coupled to a linear motor. The piston amplitude is therefore approximately proportional to the RMS voltage applied to the linear motor. Consequently, the cooling capacity is proportional to the square of the RMS drive voltage. To achieve a desired temperature in a cooling system, a control circuit must modulate the RMS drive voltage as a function of the difference between temperature measurement and a setting temperature. The control circuit contains this logic, which is summarized as follows:

$$\begin{aligned} \text{Cooling capacity} &\propto (\text{FPSC piston amplitude})^2 \\ \text{FPSC piston amplitude} &\propto (\text{Drive voltage})_{\text{RMS}} \\ (\text{Drive voltage})_{\text{RMS}} &= (\text{Drive voltage})_{\text{RMS, steady}} + \Delta \text{Volt}_{\text{For control}} \\ \Delta \text{Volt}_{\text{For control}} &= \text{function}(T_{\text{desired}} - T_{\text{thermistor_measured}}) \end{aligned}$$

A FPSC can modulate cooling capacity as well as desired cold temperature regardless of ambient temperature as long as the maximum cooling capacity is greater than heat load of the cooling system. Therefore, the desired temperature may be freely adjusted regardless of ambient temperature up to the point where the heat load is close to the maximum cooling capacity of FPSC. Capacity and temperature modulation is continuous down to 15-20% of maximum capacity without any significant loss in COP as seen in Fig. 1. This characteristic enables the cooling system to be run at its best performing status without cyclic loss or ambient temperature effects. Cold temperature variation at steady state is generally very small at approximately $\pm 0.5^\circ\text{C}$. This has been noted from testing of several applications.

1.3 Mass and Starting Current

The 40 W FPSC weighs 1.6 kg. This mass is well matched to portable cooling systems. It also increases flexibility of cooler location because a FPSC can be mounted on the top or side as well as on the bottom of the cooling system without upsetting the balance. Similar capacity compressors weigh 4.0-7.0 kg and have difficulty for location on the top or side because of vibration transmission and weight unbalance.

Starting current of the 40 W FPSC is just 0.05 A and it is not affected by ambient temperature or heat load of the cooling system. Even large capacity FPSC examples have shown starting currents of less than 0.3 A. Low starting current is a result of a unique feature in that starting is possible at very low amplitude (applied voltage) and inherently low friction due to gas bearing implementation. This suggests a long operating life for FPSCs.

1.4 Heat Transport and System COP Estimation

A generalized COP for a FPSC was given as in Equation (1). For cooling system designer, a system COP rather than FPSC COP would be a primary concern to estimate power consumption at certain conditions. For instance, a question of how long operation on a battery might last under tropical conditions for a portable cool box is crucial for designing such a product and for outlining a marketing concept. As discussed above, FPSC performance is not severely affected by ambient temperature and desired cold temperature unless used for deep freezer applications, say, below -50°C. A similar conclusion is reached for the cooling system. That is, the COP of the cooling system using a FPSC can be determined with the temperature span parameter. The ambient temperature condition such as sub-tropical, tropical, and super-tropical is not the essential limitation to design.

FPSC cooling systems need heat transport arrangements for moving energy from / to the Stirling cooler. This is different to Rankine systems where evaporators and condensers are part of the actual refrigeration cycle. Temperature differentials of the heat transport arrangements must be included for an accurate estimation of the FPSC system performance. Since the warm head (T_w) will run above the ambient (T_{amb}) and the cold head temperature (T_c) will run below the desired cabinet temperature ($T_{desired}$), the temperature span (ΔT_s) for the FPSC performance is larger than the simple difference of $T_{amb} - T_c$. $\Delta T_w = (T_w - T_{amb})$ and $\Delta T_c = (T_{desired} - T_c)$ are greatly dependent on the heat transport design of the cooling system. Typical heat transport schemes for Stirling cooling systems are direct conduction from warm / cold head, use of single-phase fluid as a heat transport media and the use of two-phase heat transfer such as thermosiphons or heat pipes. These schemes can be coupled with forced or natural convection to meet the requirements and other factors of the cooling system. Once the heat transport scheme is decided, thermal conductances for the warm and cold sides need to be determined (K_w and K_c respectively). Thermal conductance is a measure of heat transport per unit temperature. System COP and power consumption of the cooling system are determined as below based on the known parameters of heat load (obtained primarily from $K_{insulation}$ but may include other parasitic loads) and thermal conductances of the heat transport schemes (K_w and K_c).

$$\Delta T_c = \frac{HeatLoad}{K_c}$$

$$\Delta T_w = \frac{Heat\ Re\ ject}{K_w} = \frac{HeatLoad + PowerInput}{K_w} = \frac{HeatLoad}{K_w} \left(1 + \frac{1}{COP_{FPSC}} \right)$$

$$HeatLoad = K_{insulation} \cdot \Delta T_{ss}$$

Where ΔT_{ss} is temperature span of the cooling system ($T_{amb} - T_{desired}$). The temperature span (ΔT_s) of the FPSC is expressed as follows:

$$\begin{aligned} \Delta T_s &= (T_{amb} + \Delta T_w) - (T_{desired} - \Delta T_c) = \Delta T_{ss} + \Delta T_w + \Delta T_c \\ &= \Delta T_{ss} \left(1 + \frac{K_{insulation}}{K_w} + \frac{K_{insulation}}{K_c} \right) + \frac{K_{insulation} \cdot \Delta T_{ss}}{K_w} \cdot \frac{1}{COP_{FPSC}} \end{aligned} \quad (2)$$

ΔT_{ss} is typically given as a cooling system requirement and $K_{insulation}$, K_w , and K_c are determined from design, therefore Equation (1) and (2) give ΔT_s and COP_{FPSC} so that power consumption of FPSC may be calculated at any operating temperature. The total power consumption of a cooling system includes fans, light, defrosting heater, and electronics when present. The heat load will obviously include the power to the cold fan and defrost (if present) and lights (if drawing power in the cold space).

$$Power_{total} = P_{FPSC} + P_{warm_fan} + P_{cold_fan} + P_{defrost} + P_{light} + P_{electronics}$$

$$COP_{system} = \frac{HeatLoad}{Power_{total}}$$

Fig. 3 shows the calculated performance map for a cooling system with different operating temperatures based on assumed factors for $K_{insulation}$, K_w , and K_c . Regardless of the heat transport design, the temperature span is a crucial factor in the FPSC cooling system as well as in FPSC itself. In this case the FPSC cooling system is able to maintain either refrigerator or freezer temperatures under ambients of sub-tropical, tropical and super-tropical conditions.

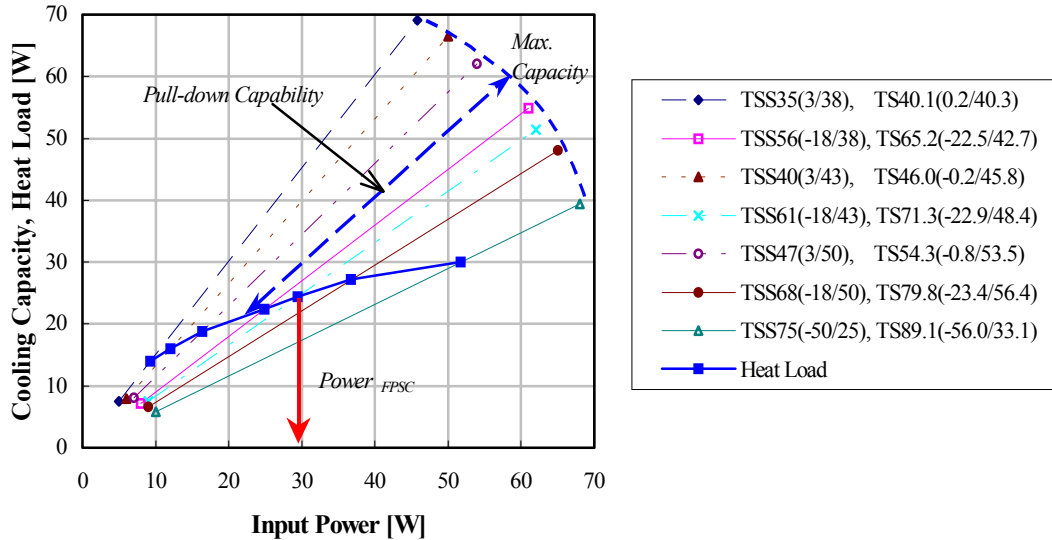

Figure 3. Calculated performance map of 40 W FPSC with temperature span of cooling system ($TSS \equiv \Delta T_{ss}$), Insulation property ($K_{insulation} = 0.4[W/^{\circ}C]$), Thermal conductance for warm and cold heat transport ($K_w = 10[W/^{\circ}C]$, $K_c = 5[W/^{\circ}C]$)

1.5 Pull-down Capability

Pull-down speed for a Stirling cooling system is relatively slow because the maximum cooling capacity of Stirling cooler is approximately 150-200% of heat load. This is usually done in order to take advantage of characteristics such as continuous operation, low cost, and a light weight. Pull-down capability is illustrated in Fig. 3. Initial pull-down capability is the cooling capacity to cool a cold space including all contents stored therein. Running pull-down capability is defined as the cooling capacity to cool any added heat load when the cold space is already at the desired temperature and at steady state. The initial pull-down capability is lower than Rankine system because of initial capacity sizing and the fact that the Rankine enjoys higher lift at the initial warmer evaporator temperatures. From Fig. 1 it can be seen that the FPSC maximum cooling capacity at a cold head of 0°C and a warm head of 35°C is about 20% more as compared to a cold head of -25°C and a warm head of 35°C. From typical compressor catalogs for similar capacity, the cooling capacity increases approximately 200% for evaporator temperature changes from -25°C to -5°C. However, the running pull-down time of the FPSC is comparable to Rankine systems because the maximum cooling capacity of the FPSC has approximately 200% of heat load, which is a similar capability to the Rankine system.

2 DESIGN EXAMPLE OF COOLING SYSTEM

In order to show a typical design procedure for Stirling cooling system, a 40 W commercially available FPSC is evaluated for use in a portable cool box. Portable cool boxes need to be light to easily carry and additionally may be used for indoor and outdoor life where ambient temperature may vary from room temperature to about 60°C (in an

automobile trunk, for example). In this example, the cold space needs to be user settable for both fresh food (0 to 5°C) and freezer (-20 to -15°C) temperatures.

Need for portable biological storage is growing for next generation bio-technology. Such a system would be a small cooled space for cold storage of bio specimens or medical items. For this application, the FPSC gives particular advantages in terms of portability, low vibration, deep temperature and easy modulation for different types temperature zones. Biological storage falls typically in the following zones: -15 to -20°C, -50°C, -80 to -120°C. For this design, a 100 W FPSC is considered and the constants $a = -0.017$ and $b = 0.42$ in Equation (1) is taken from Berchowitz (1998).

2.1 Portable Cool Box

Heat leak and thermal conductance are calculated by standard procedures not included in this paper. Corrugated fins are attached directly to the warm head of the FPSC to reject heat by way of forced convection (fan). A micro channel evaporator and condenser for a CO₂ thermosiphon is investigated to transport heat from the cold space of the portable cool box to the cold head of the FPSC. Natural convection is used for heat transfer between the cold space and the thermosiphon evaporator. A defrosting heater is not included. Electronics for temperature modulation consumes about 15% of the FPSC input power. Table 1 and Fig. 4 show the design result and layout drawing.

Table 1: Design Result of Portable Cool Box used 40 W FPSC

Volume	40 l					
Heat Leak ($K_{insulation}$)	0.413[W/°C], Polyurethane foam, Wall thickness 45mm					
Heat Transport	Warm (K_w)	5.0[W/°C], Corrugated fin and forced convection, 2watts DC fan				
	Cold (K_c)	3.0[W/°C], CO ₂ thermosiphon, Natural convection				
Operating Temperatures	T_{amb} [°C]	Sub-tropical : 38		Tropical : 43		Super-tropical : 50
	T_c [°C]	3	-18	3	-18	3
Heat Load [W]	14.5	23.1	16.5	25.2	19.4	28.1
Power Consumption_{FPSC} [W]	10.7	29.2	13.8	35.0	19.0	43.9
Pull-down @ full power [Hour]	1.1	2.1	1.2	2.4	1.3	2.7

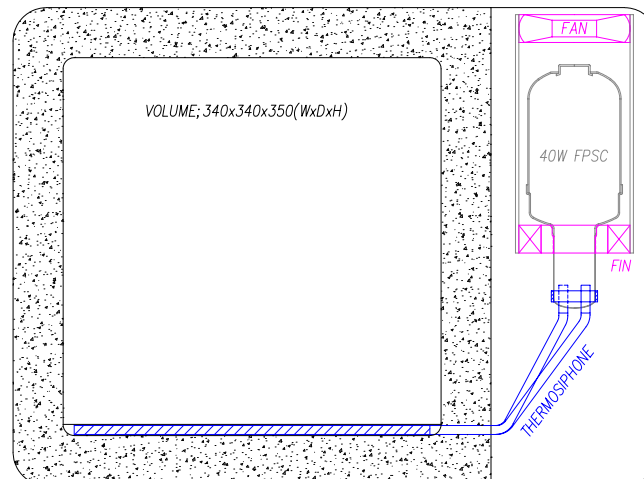

Figure 4. Layout drawing of a portable cool box (Top View)

2.2 Biological Storage

Heat rejection is accomplished by a flat plate fin and fan. The FPSC cold head is directly connected to the cold vase, which is made of aluminum plate for good heat transmissibility. Table 2 and Fig. 6 show the design result and layout drawing. Fig. 5 shows performance map for 100 W FPSC at operating temperatures.

Table 2: Design Result of Biological Storage used 100 W FPSC

Volume		20 l		
Heat Leak ($K_{insulation}$)		0.281[W/°C], Polyurethane foam, Wall thickness 45mm		
Heat Transport	Warm (K_w)	5.0[W/°C], Flat plate fin and forced convection, 4watts DC fan		
	Cold (K_c)	2.0[W/°C], Direct conduction, Natural convection		
Operating Temperatures	T_{amb} [°C]	25		
	T_c [°C]	-20	-50	-80
Heat Load [W]		12.6	21.1	29.5
Power Consumption_{FPSC} [W]		8.2	24.5	56.7

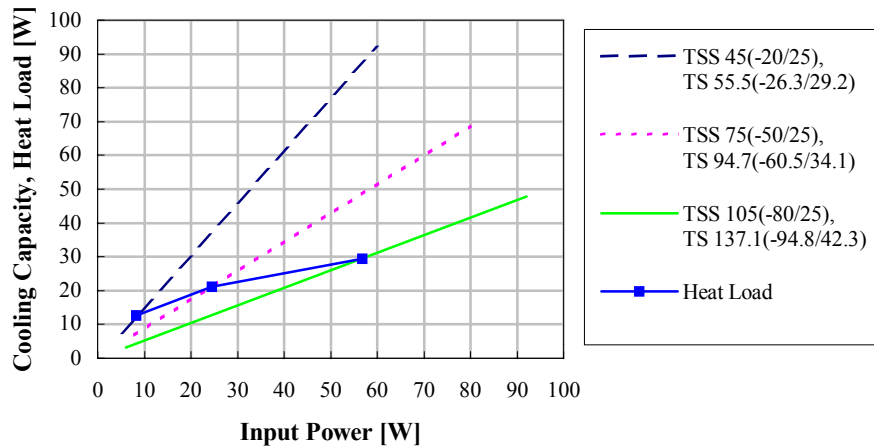

Figure 5. Calculated performance map of 100 W FPSC with temperature span of cooling system ($TSS \equiv \Delta T_{ss}$), Insulation property ($K_{insulation} = 0.281[W/°C]$), Thermal conductance for warm and cold heat transport ($K_w = 5[W/°C]$, $K_c = 2[W/°C]$)

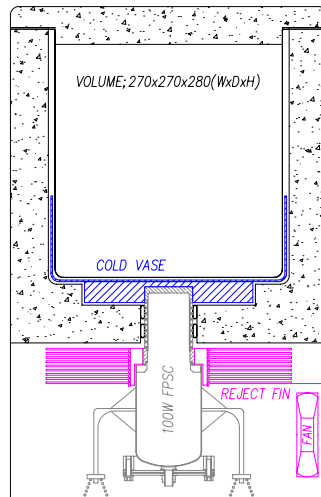

Figure 6. Layout drawing of a biological storage (Side View)

CONCLUSIONS

- A generalized COP equation for FPSCs was presented in terms of temperature span and cold head temperature. This was shown to be useful for cooling system performance estimation.
- Various physical characteristics of FPSCs were discussed such as low mass and low starting current that enable certain applications such as battery powered portability.
- A cooling system using a FPSC may be designed to operate at any reasonably expected ambient temperature such as sub-tropical, tropical, or super-tropical as long as the heat load is less than cooling capacity of FPSC.
- Initial pull-down capability is not likely to be as fast as Rankine systems, but running pull-down capability appears to be comparable to Rankine systems.
- Two design examples for Stirling cooling systems were presented showing wide temperature flexibility of FPSCs.

ACKNOWLEDGEMENTS

The authors thank Twinbird Corporation, Japan for use of their 40 Watt TB40 FPSC model.

REFERENCES

- Berchowitz D.M., 1998, "Maximized Performance of Stirling Cycle Refrigerator", *IIR Conference* at Oslo, Norway
- Berchowitz D.M., McEntee J., Welty S., 1999, "Design and Testing of a 40W Free-Piston Stirling Cycle cooling unit", 20th *IIR Conference* at Sydney, Australia.
- Finkelstein T and Polonski C., 1959, "Development and Testing of Stirling Cycle Machine with Characteristics Suitable for Domestic Refrigeration", Report W/M(3A).u.5, English Electric Company Ltd., Whestone
- Janssen M. and Beks P., 2002, "Measurement and Application of Performance Characteristics of a Free-Piston Stirling Cooler", *IIR Conference* at Purdue, USA.
- Oguz E. and Ozkadi F., 2002, "Experimental Investigation of a Stirling Cycle Cooled Domestic Refrigerator", *IIR Conference* at Purdue, USA.

Measurement and application of performance characteristics of a Free Piston Stirling Cooler

*Martien Janssen and Patrick Beks, Re/genT, Lage Dijk 22, 5705 BZ,
Helmond, the Netherlands; Tel.: +31 492 476365; Fax: +31 492 476369
E-Mail: martien.janssen@re-gent.nl *Author for Correspondence

Presented at the Ninth International Refrigeration and Air Conditioning Conference at Purdue, 2002

ABSTRACT

Measurements were performed to characterize the performance of a Free Piston Stirling Cooler over a wide range of temperatures and heat lifts. The temperature range investigated was from -120°C to $+5^{\circ}\text{C}$ on the cold head side and from 30 to 60°C at the warm head, while heat lifts from 10 to 100W were evaluated. The publication discusses aspects of the experimental part of the investigation, including a description of a method to quantify thermal losses at the cold end side.

Characteristic maps of measured system efficiency (COP) and input power were drawn as a function of the operating parameters. A regression model was applied to the experimental results, allowing calculation of the Stirling Cooler performance at any operating condition. Subsequently, the regression model has been used for a comparison study between Rankine and Stirling based refrigeration systems. By means of a case study on an upright domestic freezer, it is shown that the obtained Stirling performance characteristics are useful to predict the energy consumption of the final product. The case study also includes those aspects, which have to be taken into account in order to make a proper comparison between a Stirling and a vapor compression based refrigeration system, such as cold/warm side heat exchanger efficiencies. It is concluded that competing efficiency levels on products can be obtained with the Stirling Cooler.

NOMENCLATURE

Q	Heat [W]	T	Temperature [$^{\circ}\text{C}$]
P	Power [W]	V	Voltage [V]
COP	Coefficient of Performance [-]	I	Current [A]
\dot{m}	Massflow [kg/s]	R	Resistance [Ω]
h	Enthalpy [J/kg]	L	Coefficient of induction [H]
UA	Heat transfer coefficient [W/K]		

INTRODUCTION

To properly compare the characteristics of a Stirling based refrigeration system with a Rankine based system (usually applied), first some practical differences between both systems are discussed. Hereafter the measurement system used to characterize the Stirling cooler is explained followed by some of the test results. These test results enable a theoretical comparison of Stirling and Rankine where an example is given for a domestic freezer. Finally the main findings are summarized.

COMPARISON BETWEEN RANKINE AND STIRLING

In the Rankine system refrigerant is transported by a compressor, which pumps the refrigerant from a low to a relatively high pressure. Heat is absorbed in the evaporator and rejected in the condenser. The expansion device reduces the relatively high pressure from the condenser to the relatively low evaporation pressure. Within the Stirling cooler heat is absorbed at the cold head due to an expansion process and rejected at the warm end due to a compression process. Within an application of this cooling system often additional heat exchangers are necessary to absorb or reject the heat as the surface areas of the heads are limited.

For the compressor applied in a Rankine system the efficiency of the compressor is typically expressed by its coefficient of performance, which is calculated according to the following formula:

$$(1) \quad COP_{rankine} = \frac{Q_{cool}}{P_{input}}$$

The COP of the compressor corresponds with the performance of the compressor at a specific operating point i.e. a specific condensation and evaporation temperature. Globally, different standards apply, e.g. ASHRAE and CECOMAF. These standards only represent the COP at exactly prescribed conditions. In the practical Rankine cycle the COP can be completely different. Therefore, the COP from the catalogue data cannot directly be related to the practical cooling system. For comparison with the Stirling COP it is recommended to calculate the actual cooling capacity on a Rankine system with the following formula (for stationary conditions):

$$(2) \quad Q_{cool} = \dot{m}(h_{evaporator\ exit} - h_{evaporator\ inlet})$$

It needs mentioning that the massflow of the compressor can be derived from catalogue data for a certain condition (evaporation, condensation temperature). However, the enthalpy values, representing the inlet and exit conditions of the evaporator, are different for each application.

For the Stirling cycle the efficiency of the cooler is also expressed with its COP. This COP is calculated according to the following formula:

$$(3) \quad COP_{Stirling} = \frac{Q}{P_{input}}$$

The COP of the Stirling cooler depends on the cold head temperature, warm head temperature and heat lift. In principle, one can compare the COP of the Rankine compressor with the COP of the Stirling cycle applying formula 2 and 3. However, one should take into account that generally Rankine refrigeration systems are controlled with a thermostat. This thermostat switches the compressor on or off, which differs from the free piston Stirling cooler, which operates in a continuously running mode. The on/off behavior in the Rankine system results in extra losses caused by the following effects:

- Thermodynamic losses; the average condensation temperature is higher and the average evaporation temperature is lower with respect to a continuously running compressor with adjusted capacity.
- Start/Stop losses; at the moment the compressor switches off, vapor from the condenser enters the evaporator. This vapor condenses in the evaporator yielding an extra heat load into the appliance.
- At the start of the compressor the current of the compressor is relatively high with respect to a continuously running compressor.

It needs mentioning that for variable speed compressors these losses are avoided. However, in some cases also these kind of compressors have to operate in an on/off mode, when low cooling capacities are demanded.

For the Stirling cooler the amount of heat from the cold and warm head has to be transported through adequate heat exchangers. This transport yields the following losses:

- Temperature losses at the cold and warm heads caused by the extra heat exchangers. In case of secondary fluids temperature losses of the fluids exist, while for a fin construction with a large surface, the fin efficiency will be lower than unity.
- Pump losses if secondary fluids are used.

It has to be noted that generally the complete construction of a refrigeration system changes, if a Stirling cooler is used instead of a normal Rankine compressor. This makes comparison of both cooling systems not a straightforward task.

THE MEASUREMENT SYSTEM

With respect to the measurements of the Stirling cooler the following details are mentioned (See figure 1).

- The Stirling motor evaluated was of the type M100B, serial number 121.
- The maximum voltage supply of the cooler was 12V (AC), at a frequency of 60 Hz.
- The Stirling cooler was supplied without a (feed back) control unit (for normal use this unit is implemented).
- The warm head of the motor was cooled with water of a controlled temperature, supplied by a pump.
- An electrical heating element was placed on the cold head. The heater was operated by means of a DC Voltage supply allowing to set different heat lifts.

- In order to minimize the heat flow from the ambient to the cold head, the cold head was insulated with Armaflex material.
- The Stirling cooler was put in a climate chamber. Measurements were taken at 25°C ambient temperature.
- Data from the tests was taken after a stable operating period of at least 0.5 hours.

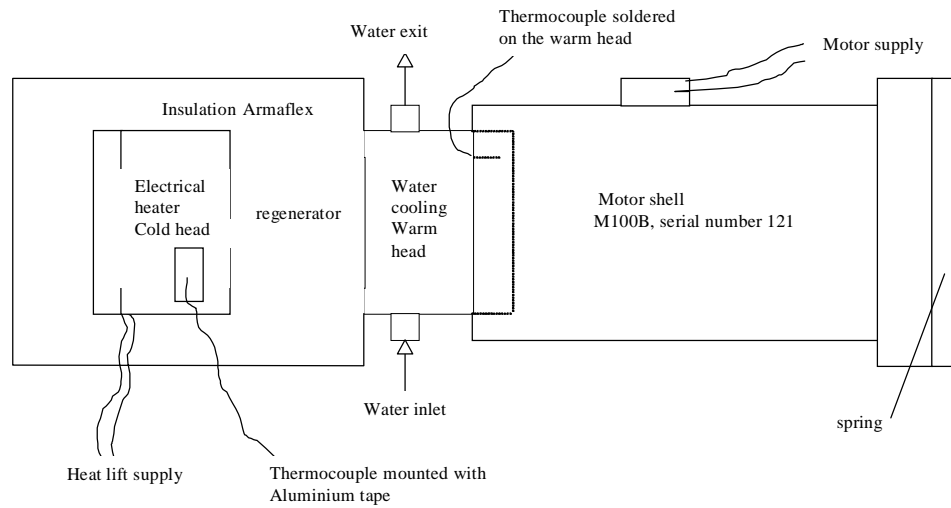

Figure 1; The Stirling cooler

MEASUREMENT PROCEDURE

Before the actual tests were started, the quality of the insulation material (Armaflex) around the cold head and regenerator was measured (See figure 2).

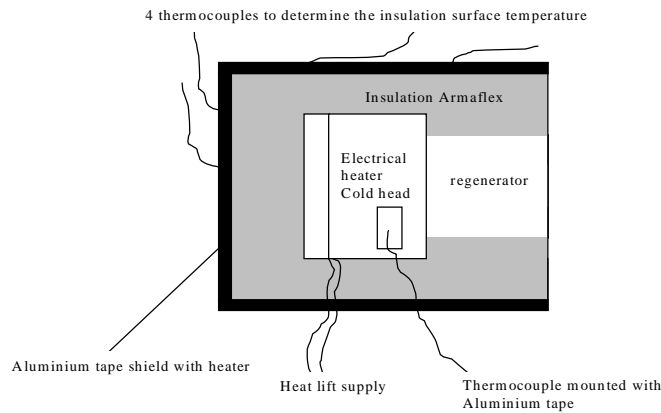

Figure 2; Cold head insulation covered with Aluminium tape

The insulation was covered with an aluminium shield. Through this shield an electrical heater was lead, which was only used to determine the insulation quality. On the aluminium shield 4 thermocouples were mounted. With these thermocouples the representative insulation surface temperature can be calculated. To obtain the heat transfer coefficient of the insulation, two measurements were performed at the same cold and warm head temperature:

Test 1: Without using the heating wire on top of the insulation a heat supply $Q_{DC\ heater1}$ was applied. This test yielded an insulation surface temperature T_1 . For this test the following equation is valid:

$$(4) Q_1 = Q_{DC\ heater1} + UA_{insulation} (T_1 - T_{cold\ head})$$

Test 2: Using the heating wire and applying a heat $Q_{DC\ heater2}$ such that $T_{cold\ head}$ is the same as in test 1. This test yielded an insulation surface temperature T_2 . For this test the following equation is valid:

$$(5) Q_2 = Q_{DC\ heater2} + UA_{insulation} (T_2 - T_{cold\ head})$$

Since the same cold head temperature (as well as the same warm head temperature and AC cooler supply) was applied in both tests, Q_2 is equal to Q_1 . Now the heat transfer coefficient of the insulation can be calculated according the following formula:

$$(6) UA_{insulation} = \frac{Q_{DCheater1} - Q_{DCheater2}}{T_2 - T_1}$$

The total heat lift measured can be calculated with the following formula:

$$(7) Q_{heat\ lift} = Q_{resistance} + UA_{insulation} (T_{outside\ insulation} - T_{cold\ head})$$

Tests were performed at the conditions described in table 1.

Condition	Normal tests	Low temperature tests
Warm head temperature [°C]	30 – 45 – 60	30
Cold head temperature [°C]	Between –60 and +5	Between -120 and -60
Nominal heat lift [W]	10 –30 – 50 – 100	20 - 40
Ambient temperature [°C]	25	25
Cooler position	Horizontal	Horizontal

Table 1; Test conditions

TEST RESULTS

For each test point the motor efficiency of the cooler can be calculated according to the following formula:

$$(8) \eta = \frac{P_{input} - P_{loss}}{P_{input}} \quad \text{in which: } P_{loss} = \frac{V_{rms}^2}{R_s} + I_{rms}^2 R_{dc} \quad \text{and } R_s = \frac{(\omega L)^2}{(R_{ac} - R_{dc})}$$

The heat transfer coefficient of the insulation around the cold head and the regenerator is 0.025 W/K (based on the cold head temperature and the outer insulation surface temperature). This coefficient is measured with an accuracy of +/- 0.005W/K.

In order to predict the performance of the Stirling cooler a regression model was applied on the test results. The following regression function, which calculates the input power of the cooler, was used:

$$(9) P_{input} = a_0 T_c^3 + a_1 T_c^2 + a_2 T_c + a_3 T_w^3 + a_4 T_w^2 + a_5 T_w + a_6 Q^3 + a_7 Q^2 + a_8 Q + a_9 (T_w - T_c) Q + a_{10} (T_w - T_c)^2 Q + a_{11} (T_w - T_c) Q^2 + a_{12}$$

Note that the heat lift is an input parameter of this equation. With this equation and optimized coefficients an average error (with respect to the measured points) on the input power of 2.3% is found between –60 and +10°C cold head temperature. With equation 3, one can obtain the COP of the Stirling cooler now.

In the following table the performance of the Stirling cooler is given for two standard operating points.

Cold head temperature [°C]	0	0
Warm head temperature [°C]	35	30
Heat lift [W]	100	33
COP [-]	2.27	2.90

Table 2; Performance at standard operation points

In figure 3 the COP values measured are drawn combined with the regression lines. The lines of 100W heat lift do not cover the complete cold head temperature field because of cooler restrictions. Namely, at 30°C warm head temperature the maximum input voltage (12V) is reached at approx. -25°C cold head temperature.

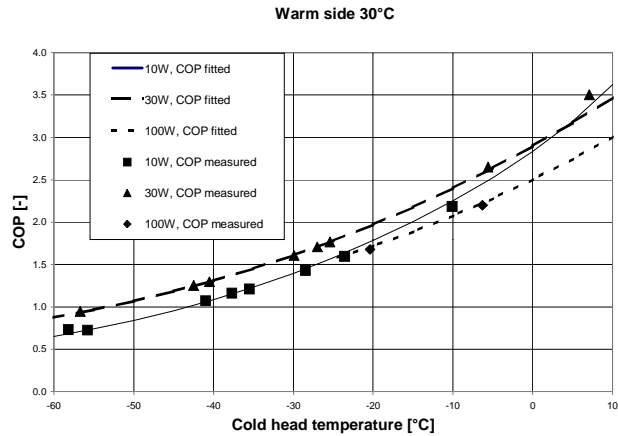

Figure 3; COP values measured and fitted at 10, 30 and 50 Watts heat lift at 30°C warm head temperature

In figure 4 the COP is given versus the heat lift. From this figure it can be concluded that:

- At very small heat lifts (<20W), a reduction in COP can be noticed.
- The effect of the heat lift on the COP is relatively small; e.g. if the heat lift increases from 20 to 80W at -20°C cold head temperature, the COP decreases only from 1.55 to 1.40.

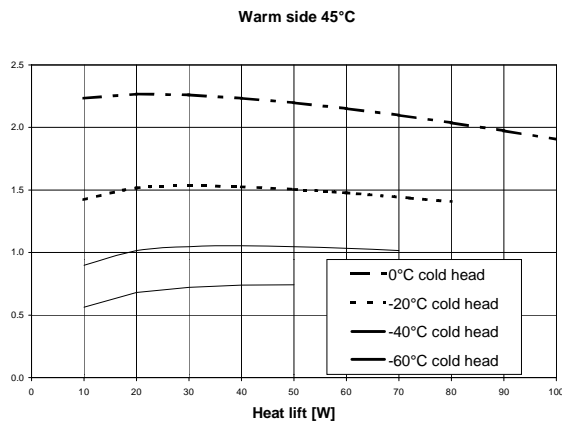

Figure 4; COP values versus the heat lift for different cold head temperatures at 45°C warm head temperature

If the ratio between the COP versus the COP_{carnot} is plotted (See figure 5), one can observe a flat profile over the entire cold head temperature range. Only at extreme high or low heat lifts the ratio reduces.

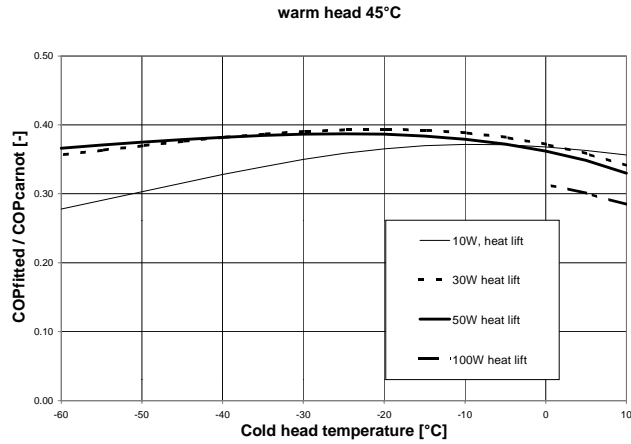

Figure 5; COP divided by COP_{carnot} versus cold head temperature

In figure 6 the motor efficiency is given versus the input power of the cooler at various cold and warm head temperatures. Generally efficiencies between 0.80 and 0.85 are calculated for the specific cooler.

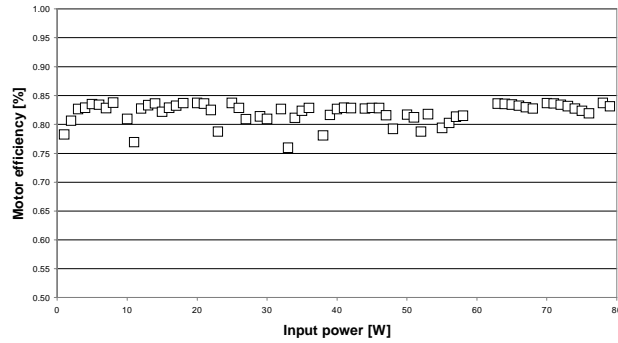

Figure 6; Motor efficiency versus the input power

With the same cooler also very low temperatures can be achieved as can be seen in figure 7. At 40 W heat lift a temperature of -92°C can be obtained at a COP value of 0.44, while at 20W heat lift this temperature can be -115°C . For this condition the COP of the cooler drops to 0.20.

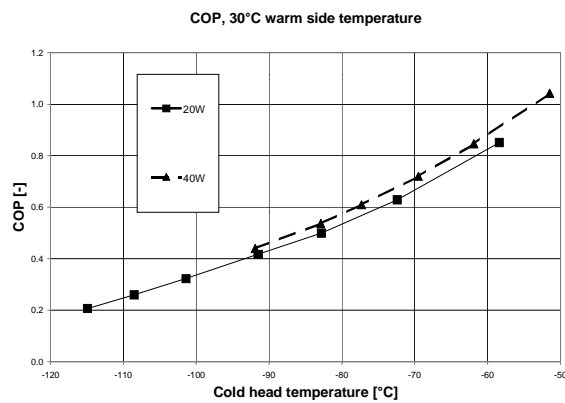

Figure 7: Low temperature runs

CALCULATION OF THE ENERGY CONSUMPTION

In this chapter an example is given how to determine theoretically the efficiency of a Stirling based system using the experimentally obtained data map. Suppose a domestic upright freezer (360 Litres) with a heat load factor of the insulation of 1.30 W/K and an average freezer temperature of -20°C . The maximum ambient temperature for this product is 43°C (tropical category).

For the Rankine system the following specifications are assumed:

- Compressor to be applied: Variable speed compressor, which has a cooling capacity of 187 W and a COP of 1.69 at 3200 RPM at ASHRAE conditions. Note that this compressor has an efficiency, which is very high compared to average compressors applied in domestic appliances.
- The cooling capacity increase due to the capillary suction tube heat exchanger is 15%.
- The condensation takes place in the complete condenser (no superheating and subcooling).
- The evaporation takes place in the complete evaporator (no superheating).
- The refrigerant applied is R600a (isobutane).

For the Stirling system the following specifications are assumed:

- The Stirling cooler to be applied is the M100B cooler.
- The energy consumption of the electronic control is not taken into account.

To evaluate the difference between both systems the electrical energy consumption of each system is calculated at various ambient temperatures. For the Rankine process it is assumed that the evaporator thermal conductance is 7 W/K and for the condenser 10 W/K. Based on the heat load of the appliance, the evaporation and condensation temperatures can be calculated (using a simple linear model). From a compressor map the operating speed is determined, which matches the desired heat load. The required compressor input power is obtained from the same compressor map. The result is shown in figure 8 over the ambient temperatures.

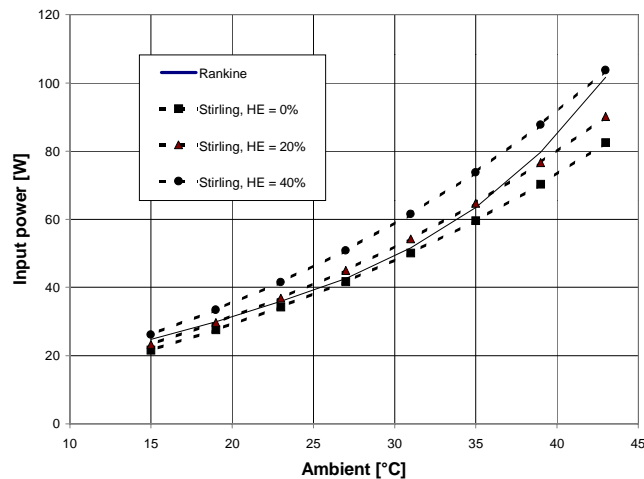

Figure 8: Estimated input power of the Rankine system with a high efficient variable speed compressor and the Stirling system (with the same heat exchanger conductance as for the Rankine, 20% lower and 40% lower respectively)

The variable speed compressor can not be operated under a certain minimum speed (due to minimum lubrication levels). In this example the compressor had to be operated in on/off mode an ambient temperature of 28°C or lower. For these conditions it is assumed that the compressor operates at the minimum speed here. During this mode the temperature differences at the condenser/evaporator are increased proportionally with the running time percentage. Note that at 43°C ambient temperature the compressor is running at a speed of 3850 RPM, which is near its maximum of 4000 RPM. This indicates that the variable speed compressor is properly selected for a tropical climate class appliance.

For the Stirling based system, a similar procedure is applied where instead of the compressor map, the Stirling performance map described earlier is applied. There is no minimum capacity to the Stirling system so it also

operates in continuous mode at low ambient temperature. For the thermal conductances it is assumed that these are equal, 20 % and 40 %, respectively lower than those of the Rankine based system. The thermal conductance on both the warm and cold side of the Stirling based system, is likely to be lower than those for the Rankine since an additional heat transfer mechanism (e.g. secondary fluids) may be required.

It can be seen that at the same conductance the Stirling system has an equal or lower energy consumption than the Rankine based system over the ambient temperature range. Obviously at reduced conductances the energy consumption of the Stirling based system increases. It is of interest to see that the Stirling performs relatively better at the high ambient temperatures. This is due to the fact that the process outperforms the Rankine process at large temperature lifts. Also at low ambient temperatures the Stirling performs relatively better. This is due to the linear motor concept allowing the possibility to operate at very low capacities, whereas the variable speed reciprocating compressor obtains a reduced efficiency due to friction losses and due to the fact that on/off cycling is required here.

CONCLUSIONS

By means of a characteristic map of the performance of a Stirling cooler, a comparison with the Rankine system can be made. To obtain such a map experimental tests on the Stirling cooler were performed in combination with a regression analysis. From these tests it is concluded that:

- At very small heat lifts a relatively small reduction in COP is noticed.
- Motor efficiencies between 0.80 and 0.85 were found for the cooler.
- At cold head temperatures of -92°C , COP values of 0.44 can still be obtained with a heat lift of 40 W.

A comparison between a Stirling system and a Rankine system is not a straightforward task. Heat exchangers efficiency differences between both systems have to be taken into account to determine the actual temperature of the cold and warm head of the Stirling cooler or the evaporation and condensation temperatures of the Rankine system. In addition on/off losses of the Rankine systems deteriorates this system substantially. A comparison was made between a high efficient variable speed compressor and the Stirling cooler evaluated on a domestic freezer. It was concluded that at high ambient temperatures the performance of the Stirling cooler can be better at high heat lifts. Also at low ambients the Stirling can perform better. This is due to the linear motor concept allowing the possibility to operate at very low capacities, whereas the variable speed reciprocating compressor obtains a reduced efficiency due to friction losses and due to the fact that cycling is required for the Rankine system.

ACKNOWLEDGEMENTS

The authors are grateful to Global Cooling, Ohio, USA, for their support of and approval for this publication.

REFERENCES

/1/ "REFPROP 6.0": Refrigerant property data, NIST, 2000.

EXPERIMENTAL INVESTIGATION OF A STIRLING CYCLE COOLED DOMESTIC REFRIGERATOR

Emre Oguz*, R&TD Engineer, Research & Technology Development Center
Arcelik A.S. 81719, Tuzla Istanbul, TURKEY; Tel.: +90 216 585 8446;
Fax : +90 216 423 3045 E-mail: emre.oguz@arcelik.com *Author for Correspondence

Fatih Ozkadi, R&TD Specialist, Research & Technology Development Center
Arcelik A.S. 81719, Tuzla Istanbul, TURKEY; Tel.: +90 216 585 8448;
Fax : +90 216 423 3045 E-mail: fatih.ozkadi@arcelik.com

ABSTRACT

A free piston Stirling cooler which is a recent prototype of a private company was integrated into a domestic refrigerator cabinet. A closed loop thermosyphon system was constructed by connecting a heat exchanger which was placed on the cold head of the Stirling cooler directly to another heat exchanger placed in the cabinet as evaporator. On the other hand, since effective heat transfer is needed on the warm head to obtain efficient operating conditions, an extended surface aluminium heat exchanger was placed on the warm head of the cooler and a fan was used to obtain forced convection heat transfer. The prototype refrigerating unit was tested for different charge quantities of the refrigerant filled in the thermosyphon loop as well as for different input voltages of the cooler. The temperatures of the key points on the cold side thermosyphon, the temperatures of the shelves of the cabinet and the input power of the Stirling cooler were recorded.

INTRODUCTION

During the 1990s ozone depletion and other environmental issues related to CFC and HFC refrigerants used in mechanical vapor compression systems in domestic refrigerators have led to considerable amount of research and development activities in the field of refrigeration. The recent proposals and discussions on energy efficiency index regulations on the other hand, have imposed more strict targets for domestic refrigerator manufacturers. While the commercialised variable capacity compressor technology or the linear compressor technology which currently seems to be at the development stage can be possible successors of the conventional vapor compressors in the future; research on alternative refrigeration methods such as Stirling cycle, magnetic cooling and thermoacoustics have reached to a certain level and these technologies can also be considered as challenging alternatives to conventional compressors.

A free piston Stirling cooler is basically a pressure vessel which operates by shuttling a certain amount of Helium gas back and forth by the combined movement of the piston and the displacer and can be determined by a cold head where thermal energy is extracted from the surroundings and a warm head where heat is rejected to the environment. Past and recent calorimetric studies on free piston Stirling coolers showed that a COP value higher than 2.5 could be reached at certain operating conditions depending on these cold and warm head temperatures [1, 2]. Another advantage of the free piston Stirling coolers is declared to be the high COP levels at low heat loads – even lower than 30 W – which can be maintained by modulating the input voltage and hence the refrigeration capacity of the Stirling cooler.

Although there are several heat transfer mechanisms – such as forced fluid convection, forced air convection or thermosyphon method – that can be applied while integrating the Stirling cooler to a domestic refrigerator cabinet, recent studies has focused on the thermosyphon system since no additional power is needed to circulate the heat transfer media. In a recent study by Berchowitz et al., the test results of a Stirling cycle cooled portable cool box are given in detail [3]. A 40 W free piston Stirling cooler had

been integrated to a 40 liter portable cool box where the thermosyphon system had been manufactured from 3 mm inner diameter copper tubing. In the thermosyphon system which had consisted of a condenser placed on the cold head of the cooler and an evaporator, carbondioxide had been used as the heat transfer fluid [3]. Presented experimental results are stated to be much better than Peltier or small vapor compression systems.

An interesting study on the application of two thermosyphon systems to a domestic freezer is presented by Larsson et al. [4]. Two thermosyphon systems had been designed; one for cooling the warm side of the compact cooler and the other for heat extraction from the cabinet. While propane had been chosen as the refrigerant for the warm side thermosyphon system; carbondioxide is stated to be used as refrigerant in the cold side thermosyphon [4]. According to the test results the lowest cabinet temperature achieved is declared to be -11°C while the saturation temperature of carbondioxide and the cold head temperature of the cooler were -18°C and -37°C , respectively.

EXPERIMENTAL SETUP AND PROCEDURE

Description of the Prototype Refrigerator

A commercially available larder refrigerator model which is described in detail in the following sections was selected as the first prototype to integrate the Stirling cooler. After removing the original components such as compressor, condenser and capillary tube the cabinet was finally turned upside down to enable the application of the thermosyphon system. The free piston Stirling cooler, the thermosyphon system for the cold side, the cabinet and the heat exchanger for cooling the warm side of the Stirling cooler are described in the following sections.

Free Piston Stirling Cooler

The free piston Stirling cooler used in this study is a first model prototype of a private company. The cooler can be defined as a hermetic unit where Helium gas is shuttled back and forth by the combined movements of the piston and the displacer. While the gas is compressed by the piston thermal energy is rejected to the environment whereas heat is extracted from the surroundings during the expansion phase of the gas; where both processes occur theoretically at constant temperature.

The spesific cooler integrated to the larder refrigerator in this study is a 220 V – 50 Hz AC unit and has three parameters that effect its refrigeration capacity and thermal performance when considered as a black box; namely the cold head temperature, the warm head temperature and the input voltage. Though there are certain differences, the cold and warm head temperatures are similar concepts to the evaporation and condensation temperatures in conventional vapor compression systems and the refrigeration capacity and COP of the cooler increase as the cold head temperature increases at constant warm head and drive voltage conditions. The input voltage on the other hand has also a positive linear effect on the refrigeration capacity but almost no effect on the COP level of the cooler [2].

Thermosyphon System

The thermosyphon system constructed in this study is basically a closed loop which is consisted of two heat exchangers; namely, the evaporator and the condenser. The evaporator is directly connected to the annular heat exchanger which is placed on the cold head of the Stirling cooler. The annular heat exchanger is used as a condenser and since the two-phase refrigerant flow is driven by the liquid column that is formed at the exit of the condenser, no other components such as a liquid refrigerant pump is needed between the two heat exchangers.

The evaporator which is manufactured from an aluminium sheet and oval aluminium piping is schematically given in Figure 1.a; where the temperature measurement points are also shown as T-1 to T-8. The side view of the upside-down cabinet and the location of the evaporator together with the condenser which is placed on the cold head of the Stirling cooler are given in Figure 1.b. This figure also includes the placement of the shelves in the cabinet with the respective 3" temperature measurement sensors shown as C-1 to C-6.

The rear view of the top portion of the cabinet – formerly the compressor compartment – where in this study the Stirling cooler and the condenser are placed is given schematically in Figure 2.a. After connecting the condenser to the evaporator, the thermosyphon system is filled with a certain amount of a refrigerant such as R134a or isobutane. When the cooler is turned on, the temperature of the cold head starts to decrease extracting heat from the refrigerant and the refrigerant condenses on the inner surfaces of the annular heat exchanger forming a liquid column between the condenser outlet and the evaporator inlet. When the amount of the liquid reaches a certain level, refrigerant circulation in the system begins with a sharp decrease in the temperature of the evaporator lines receiving liquid refrigerant. When the pressure drop of the two-phase flow in the system is balanced by the pressure difference created by the liquid column, the system reaches steady-state and hence a constant rate of massflow through the evaporator.

Cabinet and Warm Side Heat Exchanger

The overall outer dimensions of the cabinet given in Figure 1.b is $1420 \times 540 \times 540$ mm and the interior volume of the cabinet is approximately 250 lt. The cabinet, prior to the integration of the Stirling cooler, is tested both for the heatgain and energy consumption with the original compressor. The appliance constant (UA) is obtained by the so-called “reverse heat leak” test where an electric heater and a fan were placed in the cabinet and $+25^{\circ}\text{C}$ was obtained inside the cabinet in an environment of $+5^{\circ}\text{C}$. Since the compressor was not running during the test, dividing the total heat load by the temperature difference yielded an appliance constant of approximately 1.25 W/K.

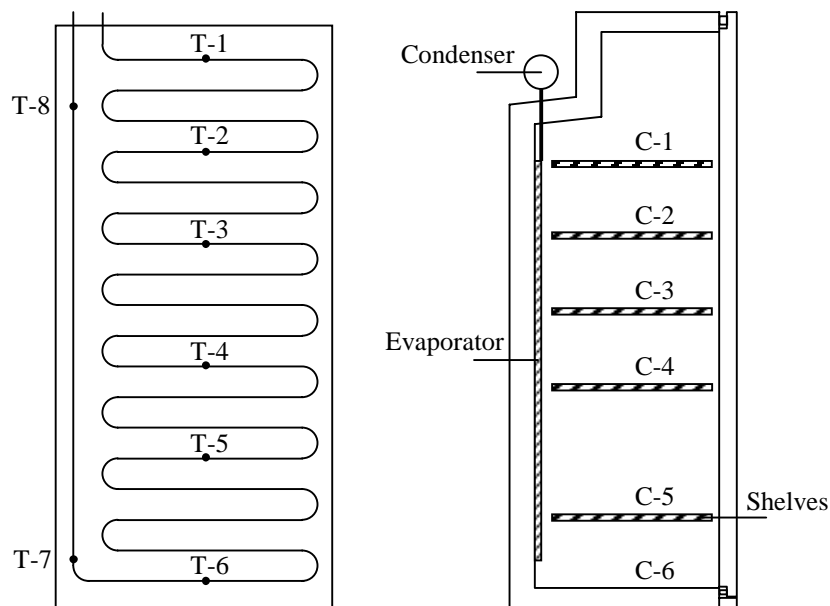

Figure 1.a : Schematic of the evaporator of the thermosyphon system.

Figure 1.b : Upside-down cabinet, location of the evaporator, condenser and the shelves.

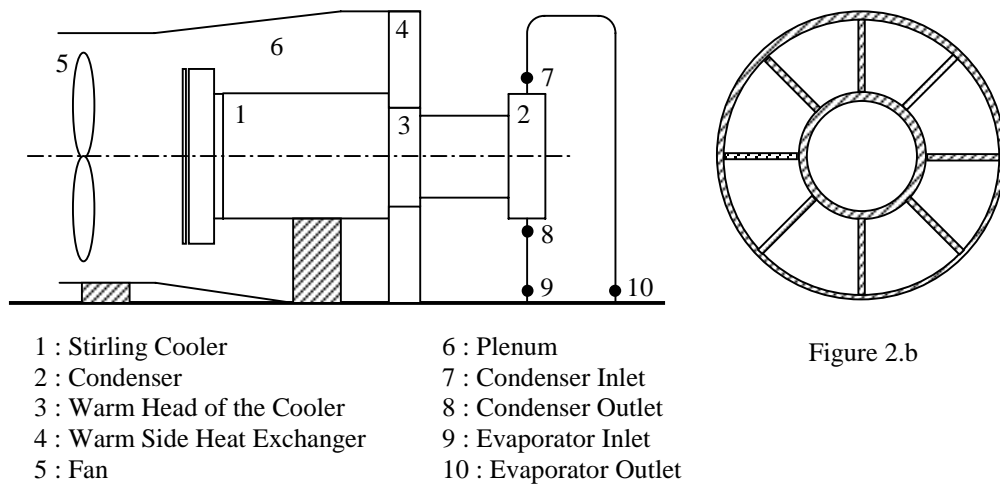

Figure 2.a : Schematic of the Stirling cooler, condenser and evaporator connections.
 Figure 2.b : Conceptual design of the warm side heat exchanger.

During the operation of the Stirling cooler, thermal energy is rejected at the warm head and therefore a heat transfer mechanism should be applied to enhance the heat transfer and to keep the warm head temperature as low as possible. In this study an extended surface aluminium heat exchanger is designed and manufactured for this purpose which is schematically given in Figure 2.b. While the inner dimension of the heat exchanger is determined by the outer diameter of the warm head of the cooler, the number of the fins and the outer diameter of the heat exchanger apparently depends on the specific application. A fan is also used to increase the convective heat transfer coefficient.

Instrumentation and Experimental Procedure

The prototype refrigerator is tested in a conditioned chamber where the temperature and the humidity of the ambient air are automatically controlled. The chamber has its own stationary measurement equipment and the temperature, voltage, current and power measurements are ensured to be within $\pm 0.3^\circ\text{C}$, $\pm 0.5\text{ V}$, $\pm 0.01\text{ A}$ $\pm 0.5\text{ W}$ respectively. In addition to the 8 points on the evaporator of the thermosyphon system and the 6 points in the cabinet; evaporator outlet, condenser inlet and outlet and Stirling cooler warm and cold head temperatures are measured. The temperature of the ambient air is recorded at two locations where the sensors were placed at both sides of the cabinet. The input voltage to the cooler was measured as well as the current and power consumption of the cooler. The sampling frequency for all of the tests is 1 Hz.

At the beginning of each test the input voltage of the cooler is adjusted to a certain value and steady-state operation is observed after a certain time interval which is typically 24 hours. After the steady-state period is determined, which ranges from 240 minutes to 1440 minutes, the average values of the parameters are calculated for that specific test and accepted as the test result.

The ambient temperature is $25 \pm 0.5^\circ\text{C}$ for all of the tests and during the specified steady-state intervals the temperatures inside the cabinet are well within $\pm 0.3^\circ\text{C}$ for 240 minute tests and $\pm 0.7^\circ\text{C}$ for the tests that last longer than 1000 minutes.

TEST RESULTS

In order to determine the effect of the charge quantity and input voltage, 11 tests are conducted with R134a as the refrigerant of the thermosyphon system. The cold head temperature, power consumption of the Stirling cooler, evaporation temperature and the average temperature inside the cabinet are given in Figure 3 for different input voltage and refrigerant charge levels. An important point to note is the calculation method of the evaporation temperature. Since, depending on the charge quantity of the refrigerant, superheat was observed in the evaporator for some cases, the evaporation temperature is calculated as the average temperature of the evaporator lines that do not contain superheat (e.g. T-1 through T-4). This issue is addressed also in Figure 4. As expected, the cold head, evaporation and average cabinet temperatures decrease as the input voltage of the Stirling cooler is increased. However, while cold head temperature is higher when switched from 46 to 38.5 grs, it is considerably lower when switched from 38.5 to 29.2 grs. This may be due to the partial blockage of the two-phase flow because of the excess liquid refrigerant accumulation at the bottom line of the evaporator for 46 grs; and insufficient liquid and therefore driving force for 29.2 grs which in turn effects the rate of massflow and condensation characteristics in the condenser, which is placed on the cold head of the cooler. The average cabinet temperature profiles on the other hand are similar to the evaporation temperature characteristics. However, the average temperature inside the cabinet is lower for 38.5 grs for the same input voltages. This may be explained by the higher cold head temperature and accordingly higher refrigeration capacity for 38.5 grs in which case the rate of massflow should also be optimal supporting the arguments about liquid refrigerant blockage and insufficient liquid column height.

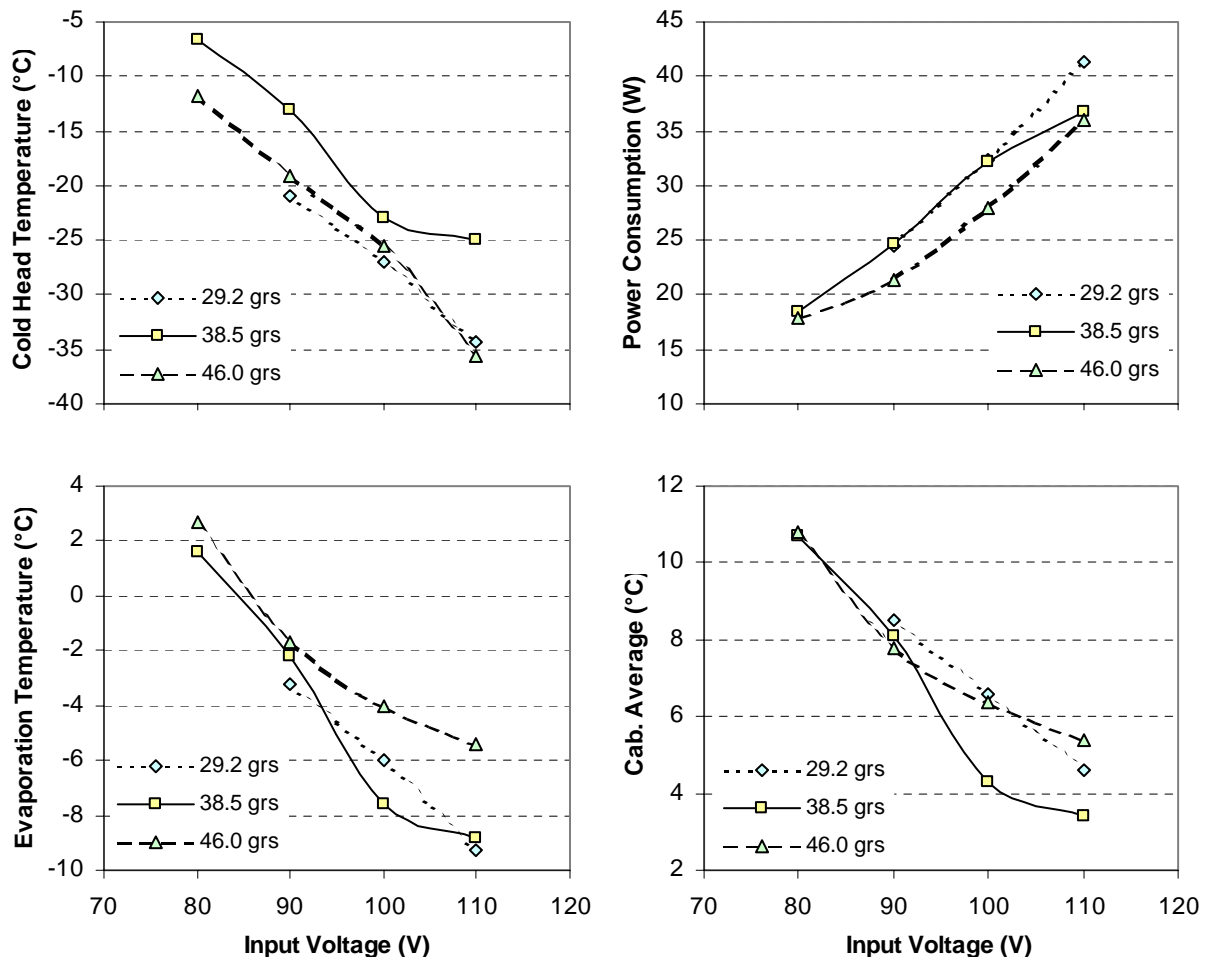

Figure 3 (a) Cold head temperature (b) Power consumption (c) Evaporation temperature and (d) Cabinet average temperature vs input voltage for different charge quantities of R134a.

In Figure 4 steady-state period of 29.2 gr R134a test at input voltage of 110 V is given. Referring back to Figure 1.a; T-2, T-3 and T-4 are not shown for clarity since they are very close to T-1 (-9.3°C). However, superheat is observed at point T-5 (-4.2°C) and onwards at T-7 (-1.7°C) and at T-9 (10.2°C) which is the evaporator outlet temperature measured outside the cabinet.

The power consumption given in Figure 3(b) does not include the fan power. Originally a no-frost appliance fan is used but since the fan motor technology has improved considerably a fan with a power consumption of 2 W can be chosen; hence it is thought to be better to focus on the power consumption of the Stirling cooler. For an average cabinet temperature of 5°C the interpolation of the data of 38.5 gr tests yields a power consumption of approximately 30.5 W which results with an energy consumption of 732 Wh/24h at 25°C ambient temperature. For the specific refrigerator cabinet under consideration this value equals an energy efficiency index of 88 with an appliance label C.

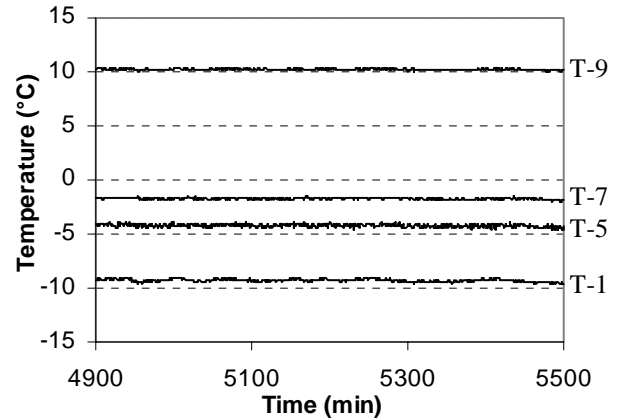

Figure 4. Steady-state period of 29.2 gr R134a test at input voltage of 110 V.

THEORETICAL ANALYSIS

In this section, a simple theoretical analysis based on both previous experimental results and fundamental heat transfer concepts is presented. Previous studies showed that the COP of this specific cooler can be calculated by the equation

$$\text{COP} = 1.5854 \times \ln(\text{COP}_C) - 0.8391 \quad (1)$$

where COP_C is the Carnot COP based on the cold and warm head temperatures. This equation, which was derived from calorimetric data obtained for input voltages between 80 and 100 V at a constant warm head temperature of 30°C, is taken from a recent study [5] which contains similar test results to the previous calorimetric measurements [2]. Refrigeration capacity on the other hand can be represented as a linear function of cold head temperature for a certain input voltage and warm head temperature [2, 5]. Since the cold and warm head temperatures are known for the prototype refrigerator tests, COP, capacity and input power of the cooler can be calculated using the equations obtained from calorimetric data. These values are given in Table 1.

After calculating the COP by equation (1) as a function of Carnot COP, which is based on experimental values of cold and warm head temperatures, refrigeration capacity of the cooler is also calculated. Dividing these values to each other yields a calculated input power value which is shown in row 12 of Table 1. It can be seen that the calculated values are in $\pm 10\%$ agreement with the experimental results which is a little bit higher than expected. The main reason for this discrepancy is thought to be the difference in the warm head temperature. Since the appliance constant is known, the heatgain of the cabinet and the heat leak to the system can be calculated as follows

$$Q_{\text{Heatgain}} = UA_{\text{Cabinet}} (T_{\text{Ambient}} - T_{\text{AC}}), \quad Q_{\text{Heatleak}} = Q_{\text{Capacity}} - Q_{\text{Heatgain}} \quad (2)$$

where T_{AC} is the average cabinet temperature, Q_{Heatleak} is the heat transfer that occurs to the system from the ambient and Q_{Capacity} is the calculated capacity of the cooler. Though the condenser and the refrigerant line outside the cabinet is insulated to a certain extent, considerable amount of heat seems to be transferred to the system. Cabinet design changes should be made to eliminate this heat leak.

Table 1. Calculated and experimental parameters for prototype refrigerator tests.

	29.2 grs R134a		38.5 grs R134a		46.0 grs R134a	
	90 V	100 V	90 V	100 V	90 V	100 V
Cold head (°C)	-21.0	-27.0	-13.1	-23.0	-19.2	-25.6
Warm head (°C)	32.0	34.2	33.3	35.1	31.4	32.8
Evaporation (°C)	-3.2	-6.0	-2.2	-7.6	-1.7	-4.0
Average cabinet (°C)	8.5	6.6	8.1	4.3	7.8	6.4
Ambient (°C)	24.7	25.2	25.2	25.2	24.7	24.9
Input power (W)	24.4	32.3	24.6	32.1	21.4	28.0
Calculated capacity (W)	36.5	41.6	41.7	44.9	37.7	42.8
Carnot COP	4.76	4.02	5.60	4.31	5.02	4.24
Calculated COP	1.634	1.367	1.893	1.475	1.718	1.451
Calculated input power (W)	22.36	30.43	22.02	30.41	21.95	29.47
Input power error (%)	8.3	5.8	10.5	5.3	-2.6	-5.2
Heatgain of the cabinet (W)	20.25	23.25	21.38	26.13	21.13	23.13
Heat leak to the system (W)	16.29	18.36	20.32	18.74	16.59	19.62
Evaporator overall UA (W/K)	N/A	N/A	2.08	2.20	2.22	2.22
Condenser outlet (°C)	N/A	N/A	-1.1	-6.1	-1.0	-3.1
Condenser overall UA (W/K)	N/A	N/A	3.47	2.65	2.07	1.90

For simplicity, the heatgain of the cabinet is thought to be equal to the capacity of the evaporator and an overall heat transfer coefficient (which also includes the efficiency of the aluminium plate acting as a fin) is calculated as follows

$$UA_{\text{Evap}} = Q_{\text{Heatgain}} / (T_{\text{AC}} - T_{\text{Evap}}) \quad (3)$$

where T_{Evap} is the evaporation temperature which is an experimental value. This calculation results with an overall evaporator performance of 2.1 to 2.2 W/K for the four cases. 29.2 gr tests are not included in this calculation due to the high superheat in the evaporator lines. The condenser outlet temperatures, which are on average 1.5°C higher than the evaporation temperature, are also given in Table 1. These values are used to calculate the overall condenser performance as follows

$$UA_{\text{Con}} = Q_{\text{Capacity}} / (T_{\text{CO}} - T_{\text{CH}}) \quad (4)$$

where T_{CO} , the condenser outlet temperature, is taken to be equal to the condensation temperature and T_{CH} is the temperature of the cold head of the Stirling cooler.

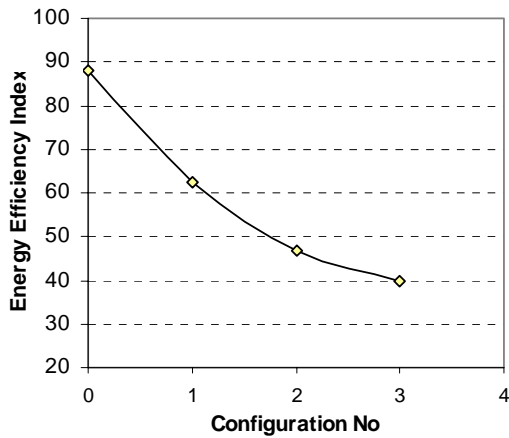

Configuration	0	1	2	3
Heatgain (W)	25.0	22.5	20.0	17.5
Heat leak (W)	18.7	14.9	11.2	7.5
Evaporator UA (W/K)	2.20	2.42	2.64	2.86
Condenser UA (W/K)	2.65	2.92	3.18	3.45
Energy cons. (Wh/24h)	732	518	390	331
Energy efficiency index	88	62	47	40

Figure 5. Potential energy efficiency improvement of the current prototype Stirling cycle cooled refrigerator.

In order to have a better picture of the potential energy efficiency improvements a backward calculation procedure is applied. Cabinet heatgain and heat leak to the system is reduced, evaporator and condenser performances are increased and the evaporation temperature is calculated by equation (3). Condensation temperature is estimated to be 1.5°C higher than the evaporation temperature and then the cold head temperature is calculated by equation (4). Warm head temperature is assumed to be 35.1°C and the COP, which is independent of the input voltage, is calculated by equation (1). Hence, dividing the capacity by the COP value the input power of the cooler is obtained. The results are given in Figure 5 in terms of energy efficiency index.

CONCLUSION

A prototype Stirling cycle cooled domestic refrigerator which operates with a thermosyphon system is built and tested at different input voltages and different charge quantities of refrigerant R134a. According to the results of the current study it may be concluded that :

- The free piston Stirling technology is a challenging alternative to be used instead of conventional compressors.
- Free piston Stirling coolers can be integrated into domestic refrigerator cabinets in several ways including the thermosyphon system and the forced air convection heat transfer mechanism. Since there are no additional components consuming energy in the thermosyphon system, this method can be preferred for both cold and warm sides of the cooler. However, more theoretical and experimental research is needed on thermosyphon systems to estimate the heat transfer and pressure drop.
- Structural design changes in the cabinet are needed while integrating the Stirling cooler. The geometry of the evaporator, the location of the Stirling cooler and the insulation system should be re-designed to benefit the potential advantages of the Stirling cooler.

ACKNOWLEDGEMENTS

The authors would like to thank to Mr. Sefik Senyurek, director of the R&TD Center, Dr. M. Yalcin Tanes, research manager of the mechanical technologies group at the R&TD Center and to Mr. Refik Ureyen, former technology coordinator in Arcelik A.S., for their endless encouragement. The authors would also like to thank to Mr. Serdar Celik, Mr. Fikri Cavusoglu and Mr. Ercan Kurtuldu for their assistance during the tests.

REFERENCES

- [1] Berchowitz, D. M., "Stirling coolers for solar refrigerators", International Appliance Technical Conference, West Lafayette, US, 1996.
- [2] Oguz, E. and Ozkadi, F., "An experimental study on the refrigeration capacity and thermal performance of free piston Stirling coolers", Proceedings of the 2000 International Refrigeration Conference at Purdue, pp. 497-504, 2000.
- [3] Berchowitz, D. M., McEntee and Welty, S., "Design and testing of a 40 W free-piston Stirling cycle cooling unit", 20th International Congress of Refrigeration, Sydney, AU, 1999.
- [4] Larsson, A., Nilsson, P. O. and Holmlund, P., edited by Palm, B., "Use of CO₂ – and propane – thermosyphons in combination with compact cooler in domestic freezer", Proceedings of the Workshop : Selected Issues on CO₂ as Working Fluid in Compression Systems, pp. 49-57, Trondheim, Norway, 2000.
- [5] Oguz, E., "Calorimetric tests of Stirling coolers", Arcelik A.S. Research & Technology Development Center Internal Report, ANN-144, December 2000.

An Electrically Actuated Reed Valve For Use As A Pulse Width Modulated Expansion Valve

Robert Redlich, Dale Kiikka and David Berchowitz
Global Cooling Mfg. Co., Inc.,
94 Columbus Road, Athens, OH, 45701 USA

Presented at the ImechE International Conference on Compressors and their Systems,
9-12 September 2001, City University, London, UK. Reproduced with permission.

Copyright of this paper rests with Institution of Mechanical Engineers and was published in
IMechE Conference Transactions 2001-7 on Compressor and Their Systems

ISBN: 1 86058 330 X

ISSN 1356-1448

For copies of this or any other Professional Engineering Publishing publication,

Tel: 00 44 (0) 1284 718710

Fax: 00 44 (0) 1248 718692

e-mail: sales@pepublishing.com

ABSTRACT

An electrically actuated reed valve* has been developed for use as a pulse width modulated electronic expansion valve (EEV) in applications where important factors may be low cost, long life, low power consumption by the valve and its control, and control of low refrigerant flow rate. An inexpensive, non-electronic method of superheat stabilization** has also been developed. The electrically actuated reed valve has been tested in several applications and found to produce expected benefits of faster pull-down and lower steady state energy consumption. Accelerated life testing suggests no degradation of performance for at least 30 years of service.

1. VALVE CONSTRUCTION AND OPERATION

A stainless steel reed normally blocks the entrance to an orifice connecting the condenser outlet and evaporator inlet of a vapor compression refrigerator. The difference between high and low side pressures holds the EEV closed in the usual manner of a reed valve. One end of the reed is attached to a planar valve seat surface and the other to a simple magnetic actuator which, when energized, bends the reed away from its seat and admits refrigerant to the orifice. When the actuator is de-energized, the valve closes as a result of elastic restoring force of the reed and pressure forces. Figure 1 is a diagrammatic representation of the electrically actuated reed valve.

*US Patent 5,967,488. Other patents applied for.

**Patent applied for.

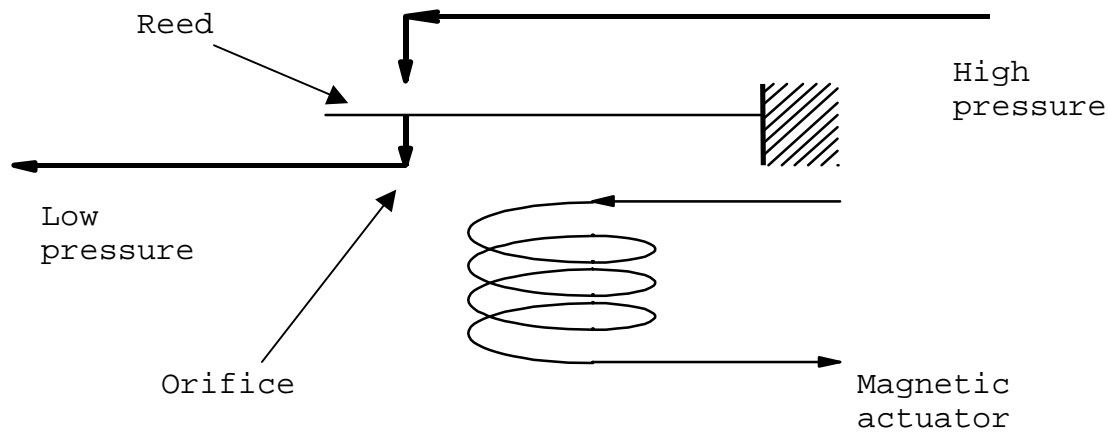

Figure 1 Schematic of Electrically Actuated Reed Valve

In operation the magnetic actuator is energized at a constant frequency (typically 1/3Hz.). Average flow rate is controlled by conventional pulse width modulation, that is, by controlling the fraction of the pulse period during which the valve is open (duty cycle).

In an application of the EEV to a vending machine refrigeration system having maximum heat lift of about 1kW and using R134a as refrigerant, the magnetic actuator generated 2N of magnetic force on the reed per Watt of power used by the actuator. This is high relative to solenoid valves and resulted in an average actuator power of about 0.5W. The EEV and its control could therefore be powered directly from the 24VDC supply already existing in the machine.

Turndown ratio, defined as the ratio of maximum to minimum attainable duty cycle, is high because of the relatively short 60 millisecond response time, which is a consequence of low actuator inertia and a low ratio of inductance to resistance of the actuator coil. For a pulse period of 3 seconds turndown ratio is about 50. Therefore, in the example of the 1 kW application, this implies the ability to control refrigerant flow down to an equivalent heat lift of about 20W. Using smaller orifice diameters than in the case of the 1kW application, maximum refrigerant flows could readily be limited to 100W of equivalent lift or less, thus suggesting the ability of the EEV to control refrigerant flows equivalent to a few Watts of heat lift. A lower limit of controllable flow is imposed by valve leakage, which measurements indicate is about 2W equivalent lift for a 0.75mm orifice and 30 bar difference between suction and discharge pressures.

2. SUPERHEAT STABILIZATION

In practice, the EEV is part of a conventional feedback loop that controls evaporator superheat by adjusting duty cycle up or down with respective increases or decreases in superheat as measured by sensors at the evaporator inlet and outlet. Because of transit time lag between a change in refrigerant flow at the evaporator inlet and a responsive change in superheat, a "proportional only" control which changes flow rate in proportion to a change in superheat

will be unstable and both flow rate and superheat will oscillate with a period approximately twice the transit time. Such oscillations can and do build up to large amplitudes, with flow oscillating between maximum and near zero. Electronic stabilization is possible, for example with a PID control [1], but for cost reasons such methods were avoided in favor of an inexpensive, non-electronic superheat stabilizer in the form of a cavity in the cold space just downstream of the evaporator. The cavity is of sufficient cross section to slow the refrigerant flow enough to allow entrained liquid to separate and collect at a low point, and has sufficient heat transfer area to vaporize collected liquid at the rate that liquid enters the cavity. The temperature of superheated vapor is sensed downstream of the cavity, within the cold space. The cavity acts as a buffer, preventing liquid from reaching the downstream superheat sensor, and causing the open-loop response to roll off at a low frequency, thus stabilizing a "proportional-only" loop providing the loop gain is not excessive. In practice, it was found that loop gain could be high enough to control superheat within 2°C over the range of heat loads that were encountered, without destabilization., and with system settling time of about 15s after a step change in superheat set point.

3. CONTROLLER

The proportional-only controller used updated versions of the ubiquitous and inexpensive 555 timer for both a 3 second clock and a controllable pulse width modulator. To avoid individual superheat adjustment of each installation, superheat sensing thermistors were matched to produce a superheat spread among a collection of valve-controller units of less than 1°C.

Starting the system from a condition where both superheat sensors are at the same temperature, e.g., after the compressor had been off for a long period, required special measures in the controller, since the basic control loop would completely shut the EEV at turn-on and it would remain shut since no superheat would build up. Two methods were used. The simplest was a hard-wired minimum duty cycle that allowed sufficient flow for build up of superheat. This was simple and inexpensive, but has the disadvantage of limiting turndown ratio. The other was a boot-up signal, applied at turn-on and having the effect of temporarily setting the duty cycle high and gradually decaying as superheat built up in the system and took over control.

Some controllers were built that incorporated a mains operated DC power supply. In others, it was possible, because of the small power requirements of the EEV and its control, to eliminate the on-board DC supply and take DC power from supplies already existing in the machine being tested.

4. ACCELERATED LIFE TESTING

Two prototype EEVs were subjected to an accelerated life test by installing each in a functioning refrigeration system in which the EEV was continuously pulsed at 5Hz., which is 15 times the normal rate. Assuming a compressor duty cycle averaging 50% in normal use, the acceleration factor of the test was 30. To enhance possible corrosion of the EEV, air flowing to the condenser was partially blocked until the temperature of the liquid reaching the valve was approximately 65°C. After 12 months of continuous accelerated life testing under

these conditions, during which no change in function of either valve was apparent, the test was stopped and one valve was removed, disassembled, and inspected. No internal corrosion, eroding of the orifice, or any other signs of degradation were seen. During the test, the EEV was pulsed 158,000,000 times, the equivalent of 30 years of service life

5. TESTS IN VENDING MACHINES

The EEV has been tested in three different vending machines, all of which were originally equipped with capillary tubes. In each case, baseline pull-down and steady state energy consumption tests were done on the original capillary system and were then repeated with the capillary tube replaced by the EEV. Faster pull-down and lower steady state power were observed in all cases. Such results would, of course, be expected with any type of expansion valve that successfully controls superheat. Pull-down data for a large, fully loaded soft drink vending machine with a fixed capacity compressor and thermostatic control of cold space temperature is graphed in Figure 2. In this case, pull-down time from 38°C to 8°C was reduced by about 11 hours. Steady state energy consumption by the same machine is graphed in Figure 3. At 19°C ambient temperature, the capillary length and bore were such as to produce nearly zero superheat, and the EEV did not, therefore, reduce energy consumption. Above 19°C ambient temperature, the evaporator of the capillary system was increasingly flooded, and the EEV reduced energy consumption by an increasing percentage as ambient temperature increased, reaching 40% reduction at 38°C.

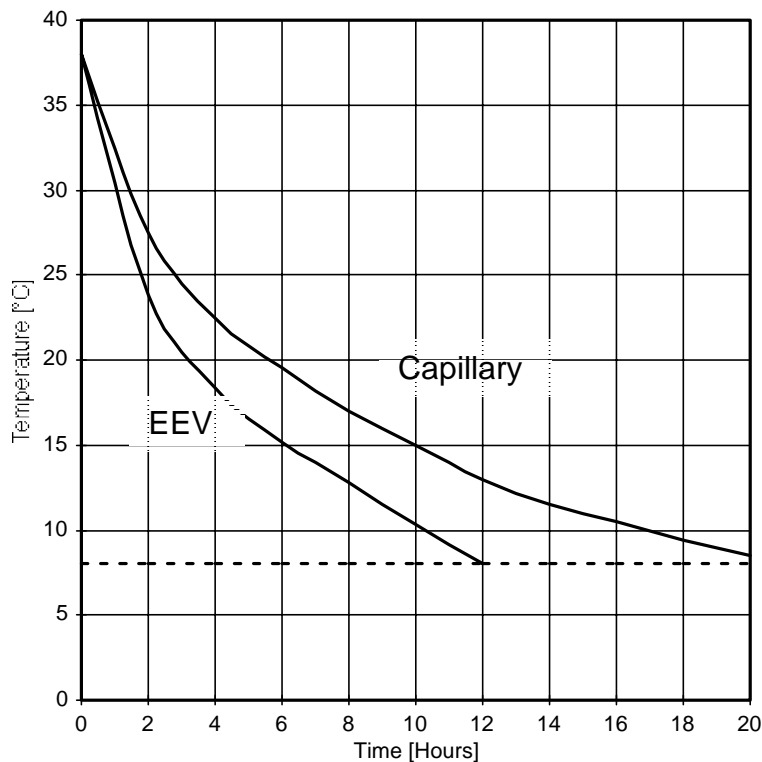

Figure 2. Pull-down From 38°C. Average Next-Product Temperature vs. Time. Capillary and EEV Systems.

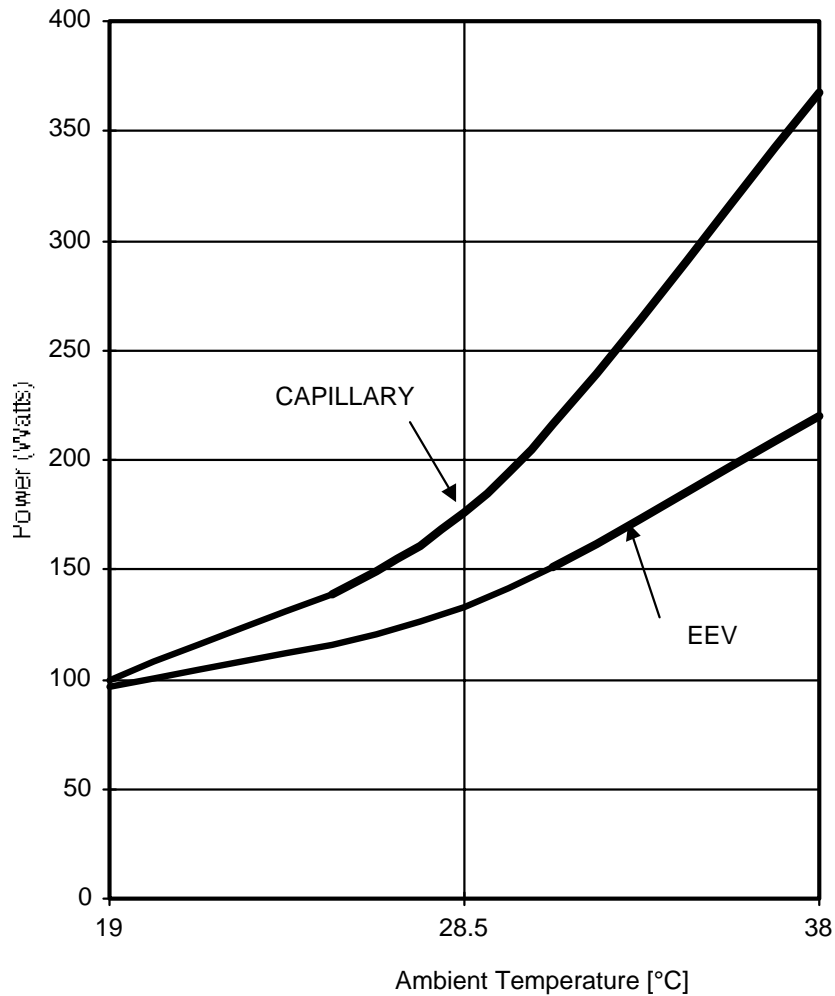

Figure 3. Power (Compressor plus Fans) vs. Ambient Temperature, Capillary and EEV Systems.

SUMMARY

The electrically actuated reed valve appears well suited for use as a pulse width modulated expansion valve, especially in smaller (and therefore lower capacity) systems where cost, reliability and long life are important.

REFERENCE

1. Hargraves, D.P. Pulse Controlled Expansion Valve and Method, Patent US 4,459,819, July 17, 1984.
2. Finn, D.P. and Doyle, C.J.. A BEMS Integrated Electronic Expansion Valve For Real-Time Optimisation of Refrigeration Evaporation. 20th International Congress of Refrigeration, IIR/IIF. Sydney, Australia. 1999.



VI CONGRESO IBEROAMERICANO DE AIRE ACONDICIONADO Y REFRIGERACION
Trabajo N°96 pp. 199-208

**ENERGY EFFICIENT FREEZER INSTALLATION USING
NATURAL WORKING FLUIDS AND A FREE PISTON STIRLING COOLER**

Stephen C. Welty – swelty@globalcooling.com Global Cooling Manufacturing
Fernando Cueva - FCueva@ikerlan.es Ikerlan-Energía

***Summary.** An investigation has been conducted as to the suitability of Stirling cycle technology for domestic refrigeration. A commercially available 73 liter freezer with an appliance constant of 0.62 W/°C was retrofitted with a free-piston Stirling cooler (FPSC). Two separate installations were tested both using natural working fluid thermosyphons. In the first installation using only a cold-side thermosyphon a 15% improvement was demonstrated over the original Rankine system at 25°C ambient. The second installation employed thermosyphons on both the warm and cold sides and achieved a 35% improvement over the original compressor installation. The second installation demonstrated a system COP of 1.31 or an energy consumption of 492Wh/day. Freezer performance and thermosyphon design issues together with future improvements are discussed.*

***Key-words.** Stirling, Refrigeration, Energy-efficiency, Natural Fluids*

1. INTRODUCTION

Concern over the environmental impact of some refrigerants has led to the investigation of alternative refrigeration technologies and working fluids. The alternative discussed here is the Stirling cycle with helium, an inert gas, as its working fluid. The heat transport mechanisms used in this installation are gravity driven thermosyphons with carbon dioxide as the working fluid in the refrigerated space and isobutane for the heat rejection apparatus.

In 1816, Robert Stirling was granted a patent (Stirling, 1816) on an air engine which became the basis of the Stirling cycle. The first documented development of a cooling device using the Stirling cycle was Alexander Kirk's invention in 1862 (Kirk, 1862, 1869). Kirk's refrigerating machine operated continuously for ten years with one day of maintenance every six months. More recently, William Beale invented the free-piston configuration, which makes it practical to hermetically seal the machine and eliminate the need for a crank driven piston (Beale, 1971, 1980). The primary benefit to removing the crank is to reduce lateral force and employ dry running pistons or gas bearings to overcome the small side loads.

Many new developments have been made in materials and manufacturing techniques, which makes the FPSC a more versatile and efficient refrigeration technology and possibly more cost effective. Within the last decade several prototype Stirling operated refrigerators and freezers have been built.

The advantages of using Stirling coolers for refrigeration are low energy consumption and reduced environmental impact, that translate to high appliance class ratings in the European and American markets and a competitive edge with more environmentally conscious consumers.

Rankine compressors generally operate on an on/off cycle whereas a Stirling cooler is under continuous operation and is lift modulated to provide the amount of cooling necessary

to maintain a specified temperature. This minimizes thermal loading of the heat exchangers and allows for high installed efficiencies. Another advantage that can be used to develop more versatile products is the variable temperature operating points of the FPSC. Efficient systems can be designed with user selectable temperatures. For example, one refrigerator model could be made that could be sold as a refrigerator or a freezer.

The FPSC has unique advantages in applications where energy is at a premium such as solar or wind energy (Berchowitz, 1996, Ewert *et al.*, 1998). The modulation characteristic of the FPSC may be used to peak power track the energy source resulting in far higher levels of energy capture. The additional energy may be stored in a thermal store thus providing cooling during low or zero energy availability (Berchowitz *et al.*, 1994).

2. PREVIOUS WORK

The earliest known Stirling freezer installation to use phase change thermal transport was a biological freezer that operated at 103 K (Tipton, 1990). Argon was used for the thermosyphon in the refrigerated space. In the heat rejection thermosyphon, HCFC-22 was used.

In 1994 an Orbiter Refrigerator/Freezer (OR/F) for NASA's Life Sciences Project Division at the Johnson Space Center was cooled by an FPSC with an acetone heat pipe thermal transport system (McDonald *et al.*, 1994). The cabinet for the OR/F had a heat leak factor of $0.53\text{W}/^\circ\text{C}$ and the energy consumption at -22°C was 1680 Wh/24hr.

In 1996 Green *et al.* at Oxford University completed a Stirling freezer prototype with a Stirling cooler and two thermosyphons. The Oxford prototype demonstrated a 12% energy savings over conventional systems. This freezer consumed 1480 Wh/24h at -20°C . A fan was used to circulate the air in the refrigerated space.

3. PROJECT GOALS

In light of the problems associated with installing a high-efficiency cooling unit with high thermal fluxes into a cabinet where low thermal fluxes are required, this project took on as one of its goals the study and implementation of efficient heat transfer techniques. Gravity driven thermosyphons appear to address this essential difficulty. Both the external heat exchanger (conventional condenser) and the internal heat exchanger (conventional evaporator) were designed to transfer heat by natural convection to eliminate the need for fans.

The project was carried out in two phases. Under the first phase, the integration of the FPSC with the cabinet was done with the main focus being the development of the carbon dioxide thermosyphon. During testing several items for further development were identified. The heat rejection for the first prototype was forced convection over extended fins. The consumption of 6 W by the fan was a large percentage of the input power. Two problems were identified with the carbon dioxide thermosyphon, (1) the bottom shelf of the cabinet space was several degrees higher than the other spaces, and (2) when the FPSC stopped abruptly because of a cut in power then the thermosyphon would not reestablish circulation and the carbon dioxide would freeze. Also, the noise level of the first installation was found to be too high.

The main goal of the second phase was to further improve the energy-efficiency by developing an isobutane thermosyphon for heat rejection and to study the problems encountered in the carbon dioxide thermosyphon. The noise problem was also studied further.

4. FREE PISTON STIRLING COOLER

The FPSC has been under development for several decades but efforts to optimize the performance for domestic refrigerator applications has occurred only during the last decade (Berchowitz *et al.*, 1995, 1998, 1999). Currently units are being tested that consistently perform at above 40% Carnot whereas the units used in these two installations had performances of about 35% Carnot. Table 1 shows some data for the FPSC used in the second installation. At the design conditions of -23°C cold side and 30°C warm side, the FPSC COP is estimated to be 1.65. Oguz *et al.* (2000) performed a thorough analysis of some M100 units of the type used here and obtained similar results.

Table 1- Bench tests of M100B #107 with sine wave voltage input

Lift	AC Voltage	AC Current	Input (W)	Acc Temp (C)	Rej Temp (C)	COP	%C
31.30	10.97	2.12	21.04	-26.30	33.00	1.49	35.76%
101.27	18.41	3.65	56.71	0.80	43.90	1.79	28.11%
34.36	10.67	1.48	14.30	-0.50	30.80	2.40	27.60%
35.97	12.07	2.13	23.64	-23.07	32.40	1.52	33.77%

5. FREEZER CABINET

The freezer used is a DUO-23 two temperature domestic refrigerator from Fagor Electrodomésticos. For the steady state condition the heat leak of the freezer cabinet is determined by the appliance constant and the internal and external temperature span of the cabinet. The appliance constant of the freezer cabinet was found experimentally to be $0.62 \text{ W}/^{\circ}\text{C}$. The design conditions for this freezer are -18°C cabinet temperature and 25°C ambient temperature. From this information the heat load can be calculated to be 26.7 W .

6. THERMOSYPHON DESIGN

From basic thermodynamics the key to maintaining the highest COP is to maintain the temperature differences between the FPSC heat transfer surfaces and the cold and warm reservoirs as small as possible. This requirement is most easily satisfied with the use of a phase change heat transfer system where the temperature difference between the evaporation and condensation surfaces is dictated by the difference in saturation pressure between the two sections.

The thermosyphon is a two phase system with the two phases of the fluid separated into different tubes. It consists of an evaporator section and a condenser section and the two transport tubes. The tube with the vapor is referred to as the vapor return line and the other tube is referred to as the liquid down line.

The liquid down line must be of a small enough diameter so that as it fills with liquid, vapor cannot go up the same tube. If a liquid column is not maintained in the down line then circulation will stop. The required height of the column depends on the pressure drop through the entire tubing structure including the condenser and the evaporator. The pressure drop in the vapor section of the tubes is much higher than in the liquid due primarily to the much higher velocity of the vapor. In addition the pressure drop through the system varies considerably not only with heat flux but also with quality. Obviously the more vapor flow in the system the higher the pressure drop.

In order for the fluid in the thermosyphon to circulate, the following inequality must be met for all operating conditions.

$$\mathbf{r}_{liq}gh > \frac{\mathbf{r}_{liq}V_{liq}^2L_{liq}f_{liq}}{2D_{liq}} + \frac{\mathbf{r}_{vap}V_{vap}^2L_{vap}f_{vap}}{2D_{vap}} + \mathbf{r}_{vap}gh + \frac{2\mathbf{s}}{D_{liq}} \quad [\text{Pa}] \quad (1)$$

where:

- L_{liq} : liquid down line [m]
- L_{vap} :vapor return line [m]
- \mathbf{r}_{liq} : liquid density [kg/m^3]
- \mathbf{r}_{vap} : vapor density [kg/m^3]
- D_{liq} : diameter of liquid line [m]
- D_{vap} : diameter of vapor line [m]
- V_{vap} :Velocity of vapor [m/s]
- V_{liq} : Velocity of liquid [m/s]
- f : friction factor
- g : gravitational constant [m/s^2]
- h : liquid column height [m]
- s : surface tension [N/m]

Inequality (1) has inherent in it the assumption that the liquid and vapor sections can be separated into two distinct sections. In actuality both the liquid and vapor will be found in a given cross section of the evaporator and the condenser. However, the important issue is to maintain the liquid line completely full and design the height for the highest capacity necessary. The inequality makes it possible to design a thermosyphon for a wide range of operating temperatures.

Many different fluids can be used in the thermosyphon and the range of operation depends on the the critical point of the fluid and on the quality at any given pressure.

The capacity of the thermosyphon is determined by the equation:

$$\dot{Q} = \dot{m} h_{fg} \quad [\text{W}] \quad (2)$$

where \dot{Q} is the heat lift, \dot{m} [kg/s] is the mass flow, and h_{fg} [J/kg] is the enthalpy of vaporization.

For a given temperature h_{fg} is fixed so the only variable determining heat load is the mass flow rate of the fluid through the thermosyphon. However, the flow rate is determined by factors affecting the pressure drop and the liquid driving height.

The main limitation of the thermosyphon is that it is driven by gravity. Since the condenser must always be above the evaporator, the FPSC must be placed below the warm-side thermosyphon and above the cold-side thermosyphon making for impractical installation in some cases.

Previous work on the thermosyphon has indicated that there are some conditions where the liquid is ejected from the condenser in periodic slugs. These slugs tend to create temperature oscillations that may in some cases diverge. Although, it was not a goal of project to understand this phenomenon in detail, some basic physical precautions were taken to reduce the likelihood of instability.

7. FREEZER INSTALLATION

7.1 Cooler configuration

Figure 1 below is a diagram of the cabinet configuration in the second installation. As mentioned, the FPSC had to be placed above the cold space and below the heat rejection thermosyphon. Since the fresh food cabinet was not used it made a convenient place to mount the FPSC. Though impractical, this offered a simple opportunity to reduce noise by completely enclosing the FPSC.

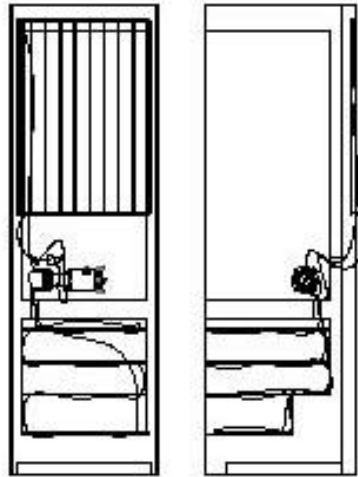

Figure 1 - Configuration of the second retrofitted FPSC Freezer

7.2 Refrigerated space thermosyphon

CO₂ is a thermodynamically appropriate fluid for operation at the cold temperature. Since CO₂ is at high pressure at the operating conditions additional design issues were presented. The vapor density being high, allowed small diameter tubes to be used without too greatly increasing the flow pressure drop. The small diameters have the advantage of lowering the material stress. The current design uses several small tubes in parallel wrapping around the cold end as shown in Fig. 2. The high heat transfer coefficient of boiling or condensing CO₂ allows for high thermal fluxes without compromising temperature differences. The parallel flow of the small tubes minimize the pressure drop and forms a convenient means to capture the condensing liquid.

The evaporator for the refrigerated space thermosyphon is quite similar to the original evaporator. The evaporator was made by removing the aluminum tubes from the shelves and replacing them with 3 mm ID copper tubing. A bottom shelf heat exchanger was not used in the first installation but was added in the second installation to address the difference in temperatures between the shelves. The bottom shelf is made of 5 mm id copper tubing soldered to a 0.5 mm thick copper plate. Copper was used for ease of fabrication but aluminum would be more practical for mass production. The evaporator is designed so that liquid CO₂ enters the top shelf then circulates down to the bottom shelves and finally emerging as vapor after going through the bottom shelf.

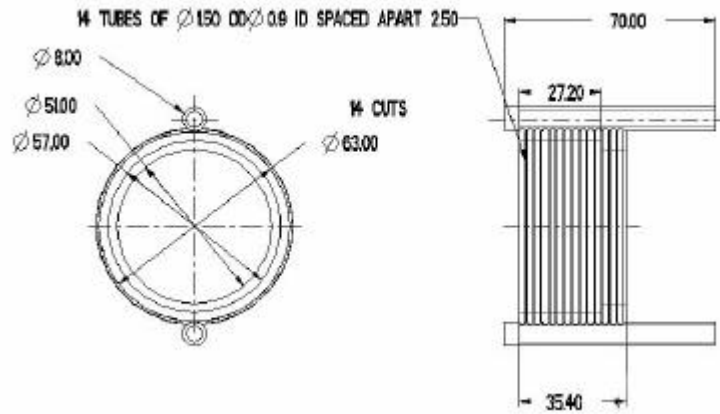

Figure 2 - Condenser for the FPSC cold head

Several different configurations of liquid down lines were used in this project to study the effect of pressure drop and liquid flow oscillations. Generally, if the pressure drop is too high then the temperature gradient across the thermosyphon is unacceptably high. However, if the pressure drop is too low it was observed that oscillations in the thermosyphon can occur. Another variable that was studied was the system density, which was changed by varying the charge. The optimal charge yielded the lowest temperature gradient between the inlet and outlet of the freezer evaporator and allowed for smooth operation without large oscillations. The charge in this case was 28 grams of CO₂.

The issue of freezing out of the thermosyphon when power to the FPSC was cut and restarted was addressed by adding a reservoir volume to the system.

7.3 Heat reject thermosyphon configuration

The first installation used a fan and copper fin forced convection heat rejection system. The fan consumed up to 6 W, which considerably decreased the overall system efficiency. For the second installation an isobutane thermosyphon was developed. The isobutane thermosyphon works the same as the CO₂ system described above with some changes due to the differences in fluid properties. The system was charged with 40 grams of isobutane that by trial and error was found to produce stable operation and minimal temperature gradient across the evaporator.



Figure 3 - External condenser for heat rejection

The isobutane has a much lower operating pressure than CO₂. With lower vapor pressures resulting in lower vapor densities, the vapor velocities are much higher resulting in a higher pressure drop. Initially a thermosyphon was built with a conventional Rankine serpentine condenser from the DUO-23. This condenser had 3mm ID tube that turned out to be much too small resulting in very high pressure drops for the design flow rate. The high pressure drop would have required an impractically long liquid height to provide the driving force for the required flow.

To address the problem of high pressure drops through the condenser, another DUO -23 condenser was modified to provide parallel flow from the top to the bottom. With this system two 8 mm ID header tubes at the top and the bottom of the condenser were attached to fourteen 3 mm tubes going down the length of the condenser. The condenser is shown in Fig. 3.

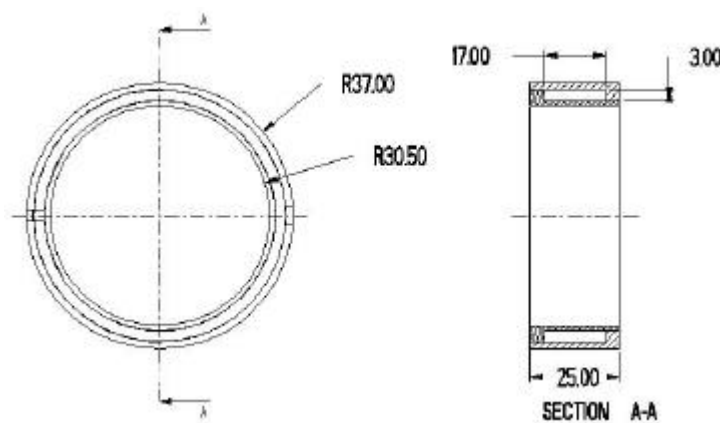

Figure 4 - FPSC annular gap evaporator

The evaporator design is simply an annular gap heat exchanger as shown in Fig. 4.

8. TEST RESULTS

Despite the problems mentioned, the first prototype demonstrated an energy reduction of 13% over the original compressor installation at cabinet air temperature of -18°C and ambient temperature of 25°C .

Sample results on the second prototype are shown in Fig. 5. The freezer was run through a cool down cycle from ambient to operating conditions at the elevated 40°C ambient to insure there was no overheating. It was then allowed to run at steady state at that ambient for an hour and a half. Oscillations in both thermosyphons are evident from the temperature profile but they are on the order of 1 or 2°C . The freezer was then set to run in a 25°C ambient and the data indicates that the performance is adequately steady and that the power consumption of the system at that ambient is about 20 W average.

Although the electronics were measured to consume 1.5 W, it was clear that eliminating the electronics from the system gave an advantage more on the order of 3 W. This can be explained by higher harmonic losses being introduced into the cooler with the square wave electronic driver.

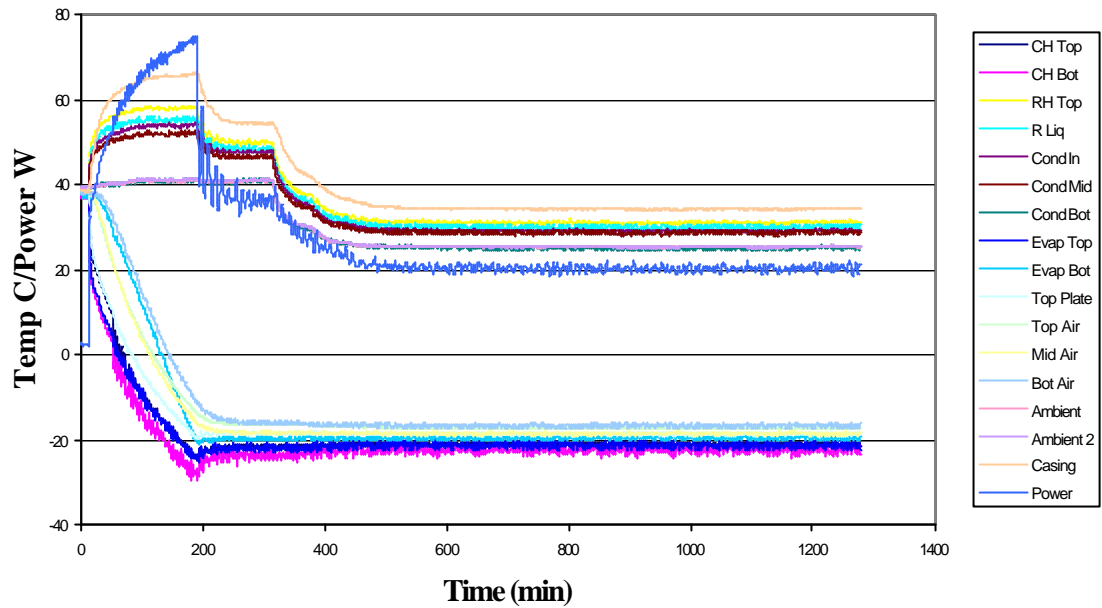

Figure 5 - Test results of final test, showing stable operation

The noise level of the installation was measured during some of the final tests. The results are shown in Tab. 2. The background noise in the test chamber was measured at 40 dBA.

Table 2 - Noise Level tests of the freezer installation

Test Condition	Current [A]	Noise Level dBA
Square wave voltage input	1.85	72.7
Sine wave voltage input	1.9	57.5
Sine wave input and door closed	1.9	42.0

The electronic driver output to the FPSC is a square wave AC voltage. The noise level with the electronic driver is much higher than when the system is run with regular sine-wave AC input. This is thought to be because of excitation of parts within the cooler at harmonic frequencies. Solutions are being evaluated that include an electronic driver that produces a near sine wave current to the cooler. However, these electronics consume more power than the square wave driver. Production units would be designed to operate directly off mains voltage using a simple Triac control for voltage regulation. Such a system would be far quieter than the square wave driver and almost as quiet as a pure sine wave input. At a power consumption of 1 W it would also be more efficient than the square wave driver.

Table 3 - Energy consumption for 25°C ambient test for different installations

Installation	Average Air Temp	Energy Consumption
Compressor Operated	-19.1C	837 Wh/24hr
Stirling Retrofitted 1	-18.3C	732 Wh/24hr
Stirling Retrofitted 2	-17.8C	492 Wh/24hr

There was considerable improvement from the first installation to the second installation. Table 3 is a comparison of energy consumption values of the two installations and clearly identifies the level of improvements made. All tests were conducted in a 25°C environment. The compressor installation is included for reference. One difference of note between the tests reported in Tab. 3 is that the compressor installation was tested with the condenser plate 3 cm from the wall. The first prototype used forced convection for the heat reject and that test condition does not apply. However, for the second prototype the results in Tab. 3 were taken without this condition being met. Later tests on the second prototype were done with this condition and indicated an FPSC warm side temperature of 37.5C and an energy consumption of 561 Wh/24hr. However, the temperature distribution throughout the thermosyphon suggests that there had been a leak in the system and the isobutane charge had become too low. Even so, the tests were repeated at ambient temperatures of 10°C and 35°C. In all cases an improvement of at least 30% over the compressor installation were demonstrated.

In both the first and second Stirling installations, the bottom air temperatures were warmer than the middle and upper sections. The first installation had a temperature difference of about 3°C from the upper shelf to the bottom shelf. On the second installation with the heat exchanger on the bottom shelf, the temperature difference is still about 2°C. This is partly due to the difference in temperature between the inlet and the outlet of the evaporator, which is about 3°C at steady state conditions.

Simple on-off tests indicated that the condenser freeze out problem had been resolved with the addition of the reservoir. Later tests showed that the system could recover after an outage of 1 minute and 5 minutes but did freeze out after an outage of 15 minutes. The thermosyphon never stopped working but the control electronics ramped the cooler up to full power and reached the freezing point before the electronics reduced the input power.

9. CONCLUSIONS AND RECOMMENDATIONS

The goals of this project were met and the two prototype installations demonstrated efficient Stirling freezer installations. Only natural working fluids were used in both installations and a significant reduction in energy consumption was demonstrated in the both cases.

The energy consumption of 492 Wh/24hr of the second installation can be improved even further by (1) decreasing the evaporator superheat, (2) using triac control electronics, (3) and improving the FPSC COP. Decreasing the evaporator superheat will increase the temperature of the FPSC cold side but the improvements are likely to be minimal. Using triac control electronics will reduce control power by 0.5 W and remove the estimated 1.5 W harmonic losses. FPSC's are currently on test that have performances above 40% Carnot and further improvements are expected. Improving the electronics along with using an FPSC with a performance of 42% Carnot will result in an estimated energy consumption of 365 Wh/24hr, which is an improvement of 56% over the conventional compressor installation.

The condenser used in the installation was modified from an existing condenser. Further work can be done to optimize it for the application.

The noise level can be reduced to an acceptable level by driving the FPSC with an AC sine wave voltage. It is also possible to design the electronics to prevent the freeze out problem discussed.

This work has shown that the use of FPSCs with thermosyphons is a potentially viable alternative to conventional refrigeration technology. Three major environmental concerns of domestic refrigeration could be addressed by this technology. Namely: ozone depletion, substances with high global warming potential, and energy consumption.

Acknowledgements:

The project was funded by Fagor Electrodomésticos of Spain. Development and testing was carried out at Global Cooling Manufacturing. Ikerlan provided further input and did further testing. The following people were involved with the project: Haoming Shao, Phu Le, Robert Peoples, Dale Kiikka, David Berchowitz, and Ruth Fernandez.

REFERENCES

- Beale, W. T., 1980, Spring and Resonant System for Free-Piston Stirling Engines, United States Patent 4,183,214.
- Beale, W.T., 1971, Stirling Cycle Type Thermal Device, United States Patent 3,552,120.
- Berchowitz, D.M., Kiikka, D., and Mennink, B.D., 1995, Recent Advances in Stirling Cycle Refrigeration, 19th International Congress of Refrigeration, The Hague, The Netherlands.
- Berchowitz, D.M., 1996, Stirling Coolers for Solar Refrigerators, 47th Annual International Appliance Technical Conference, Purdue University, Indiana, USA, May 13-25, 1996.
- Berchowitz, D.M., McEntee, J., and Welty, S., 1999, Design and Testing of a 40 W Free-Piston Stirling Cycle Unit, 20th International Congress of Refrigeration, Sydney, Australia.
- Berchowitz, D.M., 1998, Maximized Performance of Stirling Cycle Refrigerators, IIR Conference – Natural Working Fluids, Oslo, Norway.
- Ewert, M.K., Agrella, M., Frahm, J., Bergeron, D., and Berchowitz, D., 1998, Experimental Evaluation of a Solar PV Refrigerator with Thermoelectric, Stirling and Vapor Compression Heat Pumps, ASES Solar 98 Conference, Albuquerque, New Mexico, USA, June 14-17.
- Green, R.H., Bailey, P.B., Roberts, L., and Davey, G., 1996, The Design and Testing of a Stirling Cycle Domestic Freezer, IIR Conference – 2nd International Conference on the Use of Non-Artificial Substances, Aarhus, Denmark.
- Kirk, A.C., British Patents 1218 of 1862 and 2211 of 1869; Proc. Inst. Civ. Eng., 37, 244-270, 1874.
- McDonald, K., Berchowitz, D.M., Rosenfeld, J., Lindemuth, J., 1994, Stirling Refrigerator for Space Shuttle Experiments, Proceedings, 29th IECEC, Monterey, California, USA.
- Mennink, B.D. and Berchowitz, D.M., 1994, Development of an Improved Stirling Cycle Cooler for Vacuum Super Insulated Fridges with Thermal Store and Photovoltaic Power Source for Industrialised and Developing Countries, IIR Conference – New Applications of Natural Working Fluids in Refrigeration and Air Conditioning, Hannover, Germany.
- Oguz, E., and Ozkadi, F., 2000, An Experimental Study on the Refrigeration Capacity and Thermal Performance of Free Piston Stirling Coolers, 8th International Refrigeration Conference, Purdue University, West Lafayette, Indiana, USA.
- Stirling, R., 1816, British Patent 4081.
- Tipton, R.C., 1990, Development of Stirling Cycle Cooler and Integration of this Cooler into a Biological Storage Freezer, Proceedings, 6th ICC, Plymouth, Massachusetts, USA.

DESIGN AND TESTING OF A 40 W FREE-PISTON STIRLING CYCLE COOLING UNIT

DAVID M. BERCHOWITZ, JARLATH McENTEE and STEVEN WELTY

Global Cooling BV.
Groenmarkt 26,
7201 HZ Zutphen,
The Netherlands

ABSTRACT

A 40W capacity free-piston Stirling cooler (FPSC) unit has been designed and fabricated for application to portable refrigerators. Calculations suggest that average power consumption for a well insulated 30 liter box would be about 8 W at fresh food temperatures and 15 W at freezing temperatures in a 30 °C environment. Performance curves for the cooling unit are presented so that system performance may be estimated for different applications. Total mass of the unit is about 1kg. Integration into portable cool boxes with a simple thermosyphon system is shown to operate with low temperature differentials. Initial test data for the prototype unit are included.

1. INTRODUCTION

Cooling unit requirements for portable or mobile refrigeration applications demand small size, low mass, rugged construction, low environmental impact, low noise and low cost. In addition many of these applications are used where low energy consumption is an important criterion. Small capacity FPSCs appear to be a natural match for portable refrigeration. The mass advantage of these devices becomes more favorable at lower capacities as is shown in Figure 1. A FPSC unit of 50 W capacity may be as much as one sixth the mass of a Rankine compressor. In addition, as shown by Mennink and Berchowitz (1994), the energy efficiency of the device is maintained to capacities as low as 10 W. This gives the FPSC a large advantage in battery or solar powered applications. In Figure 2 the estimated performance of a FPSC is compared to Peltier (thermoelectric) devices which are often employed in portable refrigeration. All else being equal, Stirling systems should be able to operate with one fifth or less of the input energy as compared to Peltier systems.

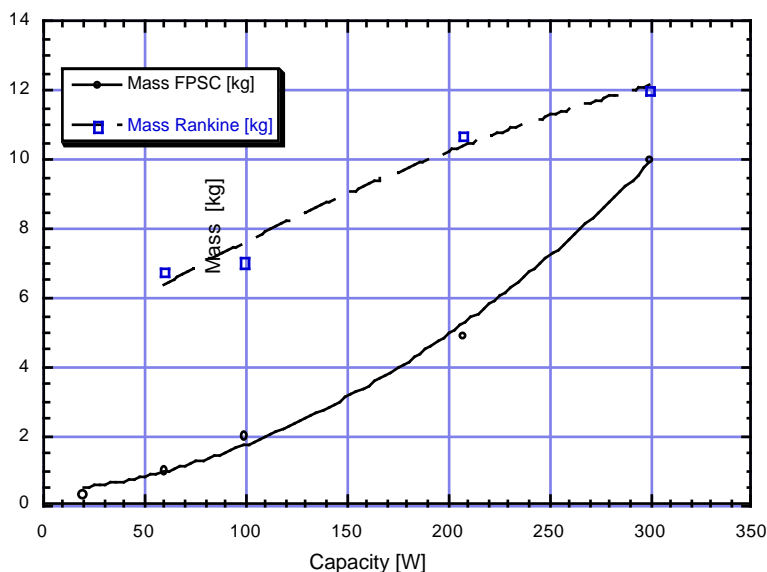

Figure 1 Mass of Rankine compressors and FPSCs. Taken from Berchowitz (1998).

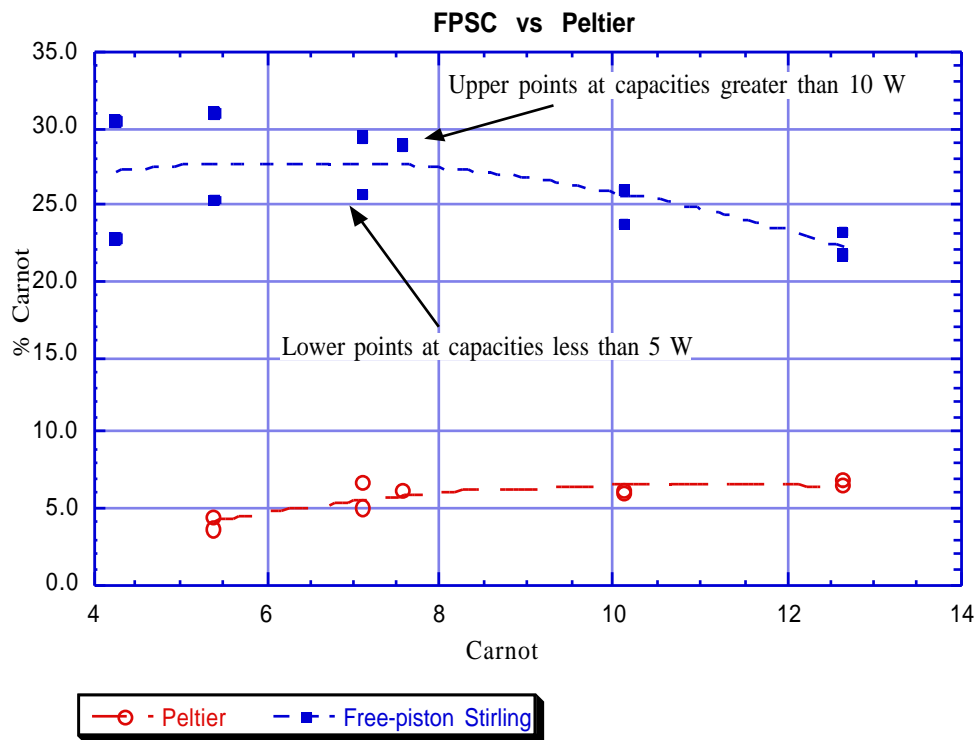

Figure 2 COP performance as a fraction of the Carnot COP

2. THE SYSTEM

2.1 Free-Piston Stirling Cooler

The Stirling cycle employs a small quantity of helium as its working medium in a closed regenerative cycle. The gas is expanded mainly in the cold side and compressed mainly in the warm side of the machine. The displacer shuttles the gas between the cold side and the warm side while the piston expands and compresses the gas. No phase changes occur during the cycle and therefore all heat transfer takes place over a finite temperature differential which must be kept as small as possible in order to maintain high COPs. The particular unit described here is a free-piston machine driven by a linear motor as is shown in Figure 3. In this machine all internal running surfaces are supported by gas bearings so that during steady operation no contact wear takes place. The entire unit is hermetically sealed to a leak rate of about 10^{-9} std cc/s. An AC voltage source (which may be derived from a DC source) drives the unit and operational characteristics are such that the lift (or capacity) are easily modulated since the piston amplitude is directly proportional to the RMS drive voltage. A more complete description of Stirling cycle theory may be found in Walker (1983), Finkelstein and Polonski (1959) and Lundqvist (1993).

For the machine presented here emphasis has been placed on low cost while at the same time maintaining a competitive efficiency and size. Design for Manufacture (DFM) techniques have been used from the outset to ensure that common and widely available processes and materials are properly considered. Solid modeling techniques together with finite element models have been integrated with component testing to maintain a high degree of confidence in the design. The parts count is low compared to similar FPSC machines.

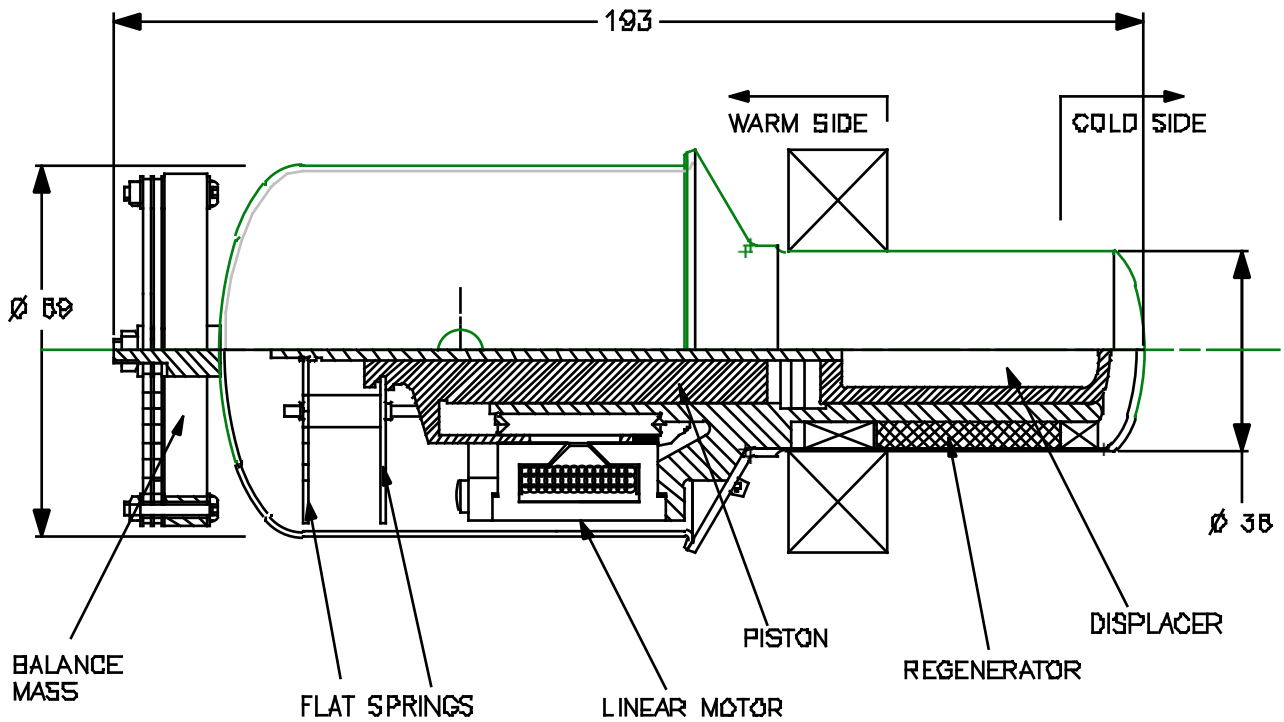

Figure 3 Small FPSC unit capable of lifting up to 40 W at freezing temperatures

2.2 Electronic Driver

Since portable refrigeration is generally powered by DC sources, it is necessary to convert the DC to AC power. This is done with a small converter which is integrated with the cooling modulation circuit. This electronic driver ensures that the cooler maintains the cabinet temperature by controlling the RMS drive voltage in response to an error signal derived from a user set temperature. Additionally, since the cooler may be easily modulated, the electronic driver contains logic that enables it to alter the cooler load on a solar panel in order to capture the maximum available energy Berchowit (1996). This latter procedure is sometimes referred to as peak power tracking.

2.3 Small Portable Cabinets

Typically portable refrigerators have a volume capacity of less than 30 liters though a few are available up to 40 liters. Construction is usually of ABS plastic with polyurethane foam insulation. Heat leak performance varies widely but the better 30 liter units achieve between 0.2 and 0.3 W / °C of temperature difference between the cold space and ambient. The lid gasket needs to be well designed in order to achieve low heat leaks. For the purposes of this paper, a heat leak of 0.3 W / °C will be assumed. Table 1 shows the expected steady state heat loads for various ambients. Typically freezer loads are not accommodated by Peltier cooled units.

Table 1: Heat loads at various ambient temperatures for a 30 liter cabinet

Ambient [C]	Freezer load at -18C [W]	Fresh food load at 3C [W]
25	12.9	6.6
30	14.4	8.1
45	18.9	12.6

2.4 Thermal Transport

The FPSC is connected to the cold space by way of a simple thermosyphon. Tests have been conducted on a 40 liter cabinet using carbon dioxide as the heat transfer fluid. In these tests the thermosyphon was fabricated from 3 mm inner diameter copper tubing. The condenser consists of a number of wraps of the tubing around the cold head of the FPSC while the evaporator consists of a few wraps of the tubing around the walls of the cold cavity. This is shown in Figure 4. Measured temperatures for the thermosyphon system are shown in Figure 5 using an M100A FPSC.

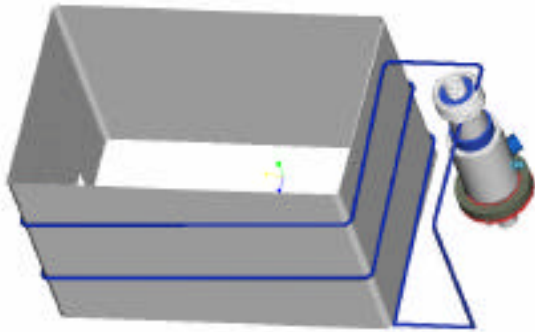

Figure 4 Thermosyphon and cold wall integration. FPSC on right side.

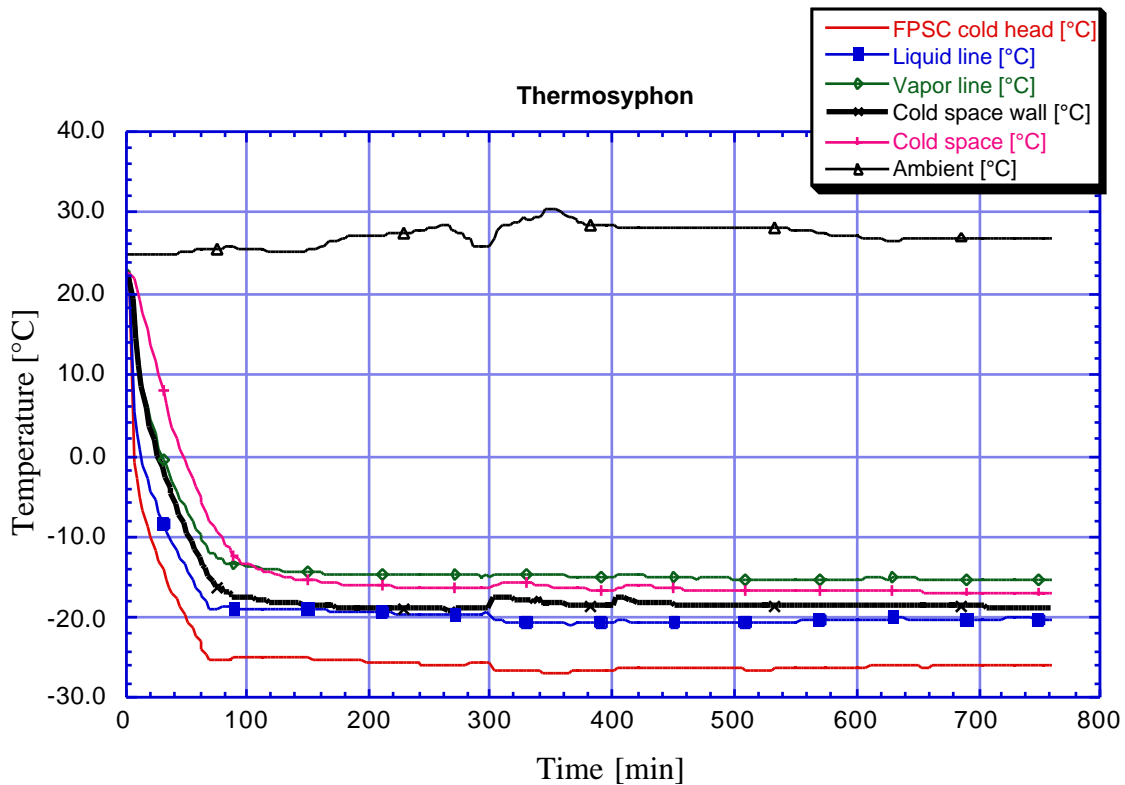

Figure 5 Thermosyphon results for a 40 liter cabinet with an M100A FPSC

3. PERFORMANCE

3.1 Expected Performance

The expected performance for the FPSC is shown in Figure 6 for two lift temperatures corresponding to fresh and frozen food conditions. In an ambient of 30°C it is expected that the reject side will operate at around 35°C while the cold side would be about 0°C for fresh food conditions and -23°C for freezing conditions. Both these operating points are possible with the machine since the heat load will only be about 14.4 W at freezing temperatures in an ambient of 30°C. In fact the FPSC will be operating at less than 40% of its maximum rated capacity for the freezer point. From Figure 6, the average input to the cooling unit will be about 11 W when operating as a freezer. The electronics will add another 2 W and the reject fan also another 1.5 to 2 W for a total of about 15 W input. Of course during cool down the FPSC will draw whatever is available up to its maximum capacity. This could be up to 30 W. Power consumption for fresh food conditions would be a lot less. In this case the heat load is 8.1 W at 30°C which suggests an input of about 4 W to the cooler for a total system input of 8 W or less.

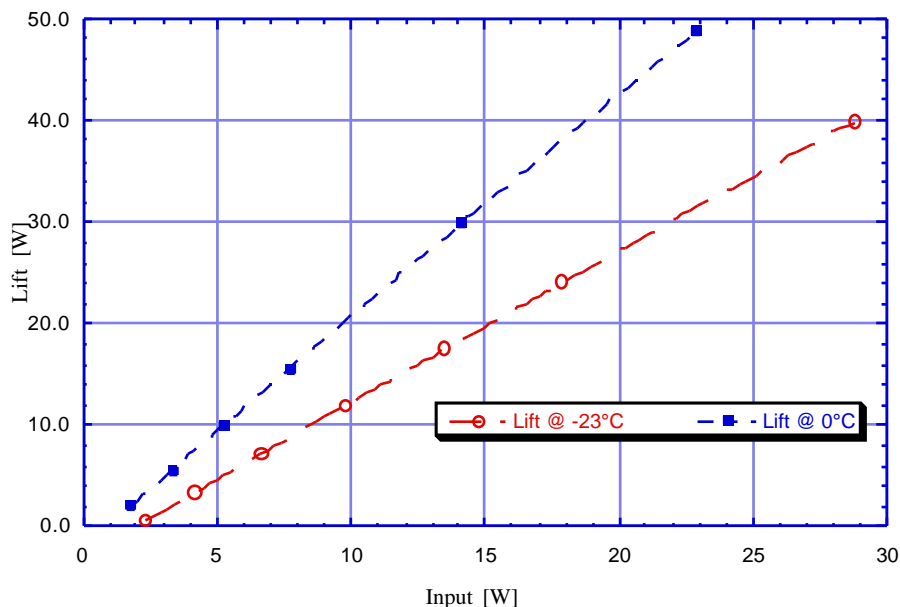

Figure 6 Performance estimation of FPSC (warm side at 35°C)

Performance estimation at warmer temperatures is shown for FPSC inputs of 10 W, 20 W and 30 W in Figure 7. For the purpose of simplification, the cold side is assumed constant at -23°C which in reality would vary depending on the load. The temperature differential between the FPSC and source or sink is also assumed constant at 5°C. A heat load line for a cabinet with 0.3 W /°C characteristic is included for reference. From this estimate, it appears that this FPSC would have no difficulty holding the cabinet at freezing conditions under extreme ambients. Actual input performance would be somewhat different than that estimated here since it depends on many things not fully accounted for. For example the design and implementation of the thermosyphon, heat rejector and reject fan have a significant effect on the operating point. Furthermore, the temperature differentials between the source and sink will be a function of the load too. As the design becomes better defined these factors will be easier to include. Parasitic losses associated with electronics and fan would add another 4 to 6 W depending on the load and ambient temperature.

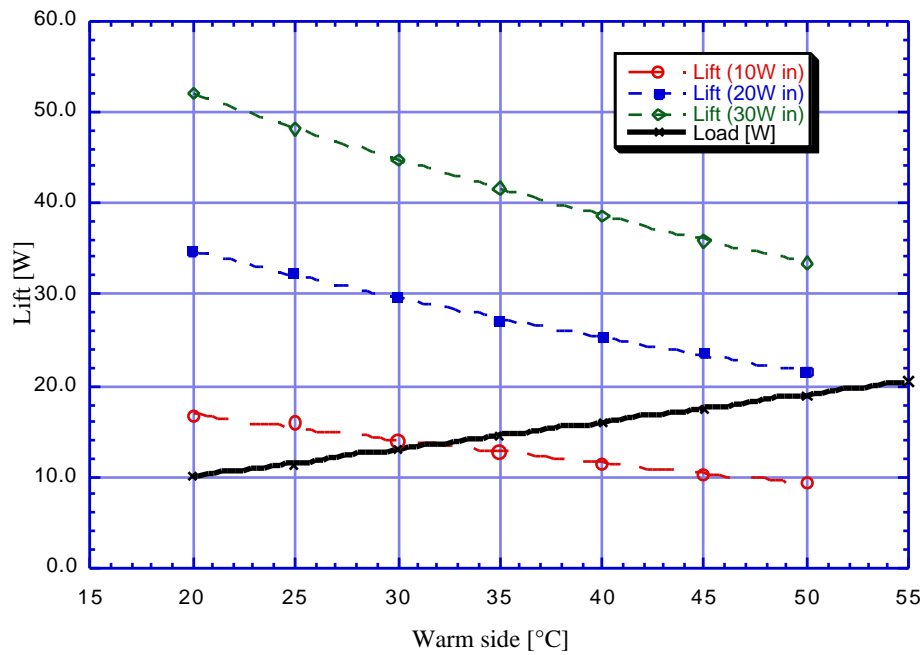

Figure 7 Effect of higher temperature conditions on freezer operation

3.2 Testing

Initial test points are shown in Table 2. At this time, performance is a little lower than expected but still much better than Peltier or small Rankine systems. It is expected that the performance will improve as familiarity with this machine develops. As presented by Berchowitz (1998), a larger FPSC with a maximum capacity of 100W easily exceeds the current COP performance of the 40 W machine. When the larger machine is run at reduced input conditions that reflect the inputs expected of the 40 W unit performance easily meets expectations. It therefore appears likely that the performance of the 40 W unit will eventually meet expectations.

Table 2: Initial test data

Warm side [C]	Cold side [C]	Voltage [V]	Current [A]	Input [W]	Lift [W]	COP
35.6	-22	6.86	2.95	18.2	17.1	0.939
28.4	-19.1	*	4.2	25.5	29.8	1.17
29.6	-17.1	*	*	19.5	24	1.23
30.3	-1.4	*	*	19.4	32	1.65

* Voltage and / or current not measured.

4. CONCLUSIONS

The size and mass of the 40 W FPSC make it well suited to portable cooling applications. Integration with such applications is expected to be by way of a simple thermosyphon. This particular machine has been designed for low cost manufacture. To some extent that tends to compromise performance. Calculations and initial testing show that performance is very much better than current Peltier cooling systems. Potential for improvement in performance is high since the machine is only limited by the Carnot maximum COP. At this time, the fraction of Carnot achieved is about 22%.

5. ACKNOWLEDGEMENT

Many people are involved in making a project such as this successful. In particular, we would like to express our sincere thanks to the discussion and contribution from Mr. Kentaro Suzuki especially concerning Peltier devices and its application to portable refrigeration. And to Mr Dale Kiiikka who performed the essential tasks of prototype fabrication and testing.

6. REFERENCES

1. Mennink B.D., Berchowitz D.M., 1994, Development of an Improved Stirling Cooler for Vacuum Super Insulated Fridges with Thermal Store and Photovoltaic Power Source for Industrialized and Developing Countries, *IIR Conference - New Applications of Natural Working Fluids in Refrigeration and Air Conditioning*, Hanover, Germany.
2. Berchowitz. D.M., September 1998, Maximized Performance of Stirling-Cycle Refrigerators, *IIR Conference - Natural Working Fluids*, Oslo, Norway.
3. D.M. Berchowitz, D. Kiiikka and B.D. Mennink, August 20-25, 1995, "Recent Advances in Stirling Cycle Refrigeration", 19th IIR Conference, The Hague, The Netherlands.
4. Finkelstein T. and Polonski C., 1959, *Development and Testing of a Stirling Cycle Machine with Characteristics Suitable for Domestic Refrigeration.*, Report W/M(3A).u.5, English Electric Company Ltd., Whetstone.
5. Lundqvist Per G., 1993, *Stirling Cycle Heat Pumps and Refrigerators*, Doctoral Thesis, The Royal Inst. of Technology, Stockholm, Sweden.
6. Walker G., 1983, *Cryocoolers*, New York: Plenum Press.
7. Berchowitz D.M., May 13-25 1996, Stirling Coolers for Solar Refrigerators, *47th Annual International Appliance technical Conference*, Purdue University, Indiana, USA.

L'ESSAIS ET L'ÉPREUVE D'UN RÉFRIGÉRATEUR STIRLING À PISTON LIBRE DE 40 W

RÉSUMÉ:

Un réfrigérateur Stirling à piston libre (appelée FPSC) de quarante watt a été designé et fabriqué pour l'usage à un congélateur portative. Des calculations suggèrent que l'usage de puissance moyenne pour un caisson à très haute isolation de trente litres serait environ 8W aux températures pour aliments frais et 15W aux températures de congélation dans un environnement de 30°C. Des courbes fonctionnements pour le réfrigérateur sont présentées pour que le fonctionnement du système sera apprécié pour des applications diverses. La masse totale du bloc est environs 1K. Faites à un congelateur portative avec une système thermosiphonne simple est montré à opérer aux températures différentiels bas. Des premières données d'épreuves pour ce prototype sont compris.

MAXIMIZED PERFORMANCE OF STIRLING CYCLE REFRIGERATORS

D.M. BERCHOWITZ Ph.D.

Global Cooling B.V., Groenmarkt 26,
7201 HZ Zutphen, The Netherlands

ABSTRACT

An investigation has been conducted into the performance of free-piston Stirling coolers (FPSC) integrated with well insulated cabinets. An issue of particular importance is identifying test conditions for FPSCs that correspond to known test conditions for cabinets. This depends to some extent on the installation methodology (Berchowitz *et al*, 1996). Test points for evaluating the potential performance of FPSCs are discussed. Using optimized free convection heat exchangers for both the warm and cold sides together with an optimized FPSC, it is shown that significant performance gains are possible for well insulated one-temperature cabinets. Freezers and two-temperature cabinets are expected to have an even greater margin. An evaluation of current level FPSC technology shows that a 25% advantage for a 365 liter one-temperature vacuum insulated cabinet should be achievable. This has been verified in an Engineering Model installation. Independent testing of a second Demonstration Model was unable to confirm these expectations owing mainly to a performance degradation of the cooler. Best estimate performance calculations show that as cabinet heat leak is reduced, the FPSC advantage improves. Mass and volume comparisons of FPSCs and Rankine compressors are included.

INTRODUCTION

The Stirling has long been noted as a potential cycle for refrigeration applications (Kirk, 1874). Work by Finkelstein and Polonski (1959) demonstrated that an air charged Stirling was capable of achieving similar or better performance to Rankine domestic refrigerator systems then available. Almost no further work was done until 1990 when General Electric Corporation commissioned Sunpower to investigate the helium charged FPSC for domestic refrigeration applications (GE 1993). This work terminated in June 1993 when refrigerant 134a was seen as a more convenient solution to the environmental problems posed by CFCs. However, at about this time it seemed likely that the FPSC may offer much higher COPs at small capacity levels compared to Rankine systems (Berchowitz 1993, Lundqvist 1993). In November 1993, a Dutch consortium of environmental groups and utilities funded a demonstration project to build a Stirling cooled, solar powered, battery-free super efficient refrigerator (Mennink *et al* 1994). One of the more important attributes to be shown by this study is the ability of the FPSC to maintain high efficiencies at low lifts. This suggested that the FPSC would be an ideal choice for supplying the small lifts expected in super insulated cabinets. Since then, further effort has been expended on performance optimization and cost reduction. The resulting machines are first generation prototypes specifically designed for consumer food refrigeration. Initial installations confirm that significantly reduced energy consumption is possible in small refrigerators (Berchowitz *et al* 1996). Other independent work along similar lines appears to agree with this conclusion (Green *et al* 1996, Kim *et al* 1997).

1 COOLER PERFORMANCE

The M100A unit described here has been developed and tested during the past two years (Figure 1). The M100A is an extensive modification of the unit originally developed for the Dutch consortium which was in turn derived from a unit developed for use aboard the Space Shuttle Discovery (McDonald *et al* 1994). Performance levels are greatly improved over the original units. COP is at least three times better than the original Space Shuttle cooler, lift is at least a factor of two better and mass has been reduced by 1 kg to 2.25 kg (the Shuttle cooler was an opposed configuration). Three versions of the M100A have been produced, namely mains units of 60 Hz and 50 Hz and low voltage 60 Hz units for solar applications. Over 100 units have been fabricated. Figure 2 shows average data taken from a number of units. Fraction of Carnot is plotted against the Carnot COP evaluated at the rejector and acceptor temperatures.



Figure 1 The M100A

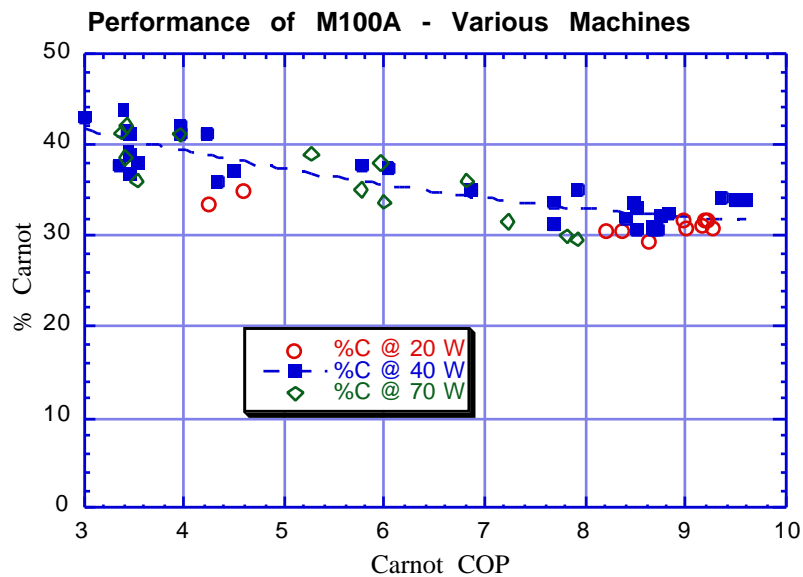

Figure 2 Percentage of Carnot versus Carnot COP

2 COMPARISON WITH RANKINE

2.1 Background

It is not a simple task to compare the FPSC with a Rankine compressor. The compressor is only part of the cooling system whereas the FPSC is a complete cooling system. On the other hand, the FPSC usually requires additional means to transport heat from the cabinet whereas the Rankine system has the convenience of an evaporator and a condenser. Typically Rankine systems are rated for given suction and discharge temperatures. The actual average temperatures at the heat exchangers may be somewhat different. FPSCs are rated for given warm and cold side temperatures measured on the cooling unit. Figure 3 compares Rankine compressors with current generation FPSCs by setting the cold and warm temperatures equal to the suction and discharge temperatures at ASHRAE conditions. Two FPSCs are shown, one higher capacity unit based on calculation and a lower capacity unit based on measurements. The FPSCs modulate so they cover a wider range of lift. The Rankine compressor capacities are determined assuming 100% run-time at ASHRAE conditions. Of course the Rankine system modulates average capacity by adjusting the duty cycle of the compressor. This introduces a further loss to the system which is not shown here. While it may seem reasonable to compare Rankines to FPSCs based on setting the suction and discharge temperatures equal to the cold and warm side temperatures respectively, this leads to erroneous conclusions owing to a number of factors. These include cabinet integration, method of capacity modulation etc. Alternative methods of comparison need to be identified. Ultimately, however, the only certain comparison is to compare installed systems on both cost and performance.

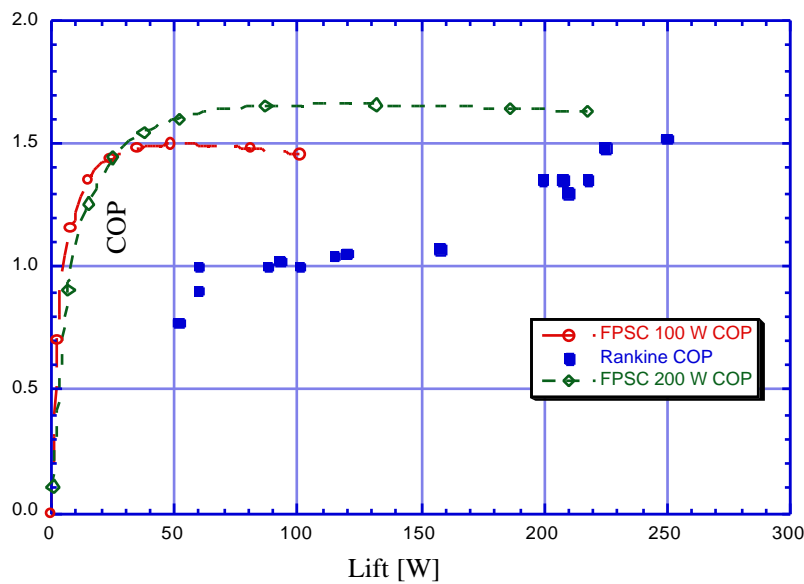

Figure 3 Comparison of two FPSCs with individual Rankine compressors
 $T_{cold} = -23^{\circ}\text{C}$ and $T_{warm} = 54^{\circ}\text{C}$. Compressors at ASHRAE conditions

2.2 Integrating FPSCs with suitable cabinets

Installing a FPSC into a suitable cabinet involves techniques completely different to conventional systems (Berchowitz and Bessler 1993, Berchowitz *et al* 1996). There will, of course, be warm and cold heat exchangers just as there are in conventional

refrigerators. The shape and form of these heat exchangers may take many different forms. Forced air, free convection and / or secondary heat transfer fluids may be used. Some studies have used heat pipes (McDonald *et al* 1994, Green *et al* 1996) and others have investigated self-pumped secondary loops (Berchowitz *et al* 1996). In the work reported here, free-convection heat transfer is utilized while heat transport to and from the external heat exchangers is effected by self-pumped secondary loops. By no means is it suggested that the system chosen for this work is the ultimate solution. Other systems may well turn out to be more practical and offer more advantages.

2.3 Base line comparisons

Both the FPSC and Rankine systems are assumed to be one-temperature refrigerators. External and internal heat exchangers are assumed to be free-convecting. The Stirling has small vibration activated pumps which circulate secondary heat transfer fluids to the external heat exchangers. Since the Stirling external heat exchangers are almost zero pressure systems, it is possible to greatly simplify their construction. It is possible to use plastic material for the heat exchangers provided that the surface area is large enough. A number of FPSC installations have been completed along these lines. Only two systems will be described in detail. The first being a conventional polyurethane foam insulated cabinet and the other being a vacuum insulated cabinet. The internal volume in both cases is approximately 365 liters. The first Engineering Model installation was completed and tested in the foam cabinet at the end of 1995. This consisted of plastic heat exchangers covering most of the internal wall area in order to demonstrate the cooled wall approach. The external heat exchanger was a single corrugated plastic sheet extending the full length of the back of the cabinet. The FPSC was mounted inside the cabinet. This does not significantly alter performance since the heat can be transported out just as easily as the cooling can be transported into the cabinet. Figure 4 shows some overall energy consumption data taken for this unit in a sensible temperature chamber. Table 1 shows typical data points. Input power is total input to the system. The power consumed by the vibration pumps has not been measured but it is estimated at being less than 0.5 W. One area of obvious improvement is the power consumption of the driver electronics. This has since been reduced to under 1 W.

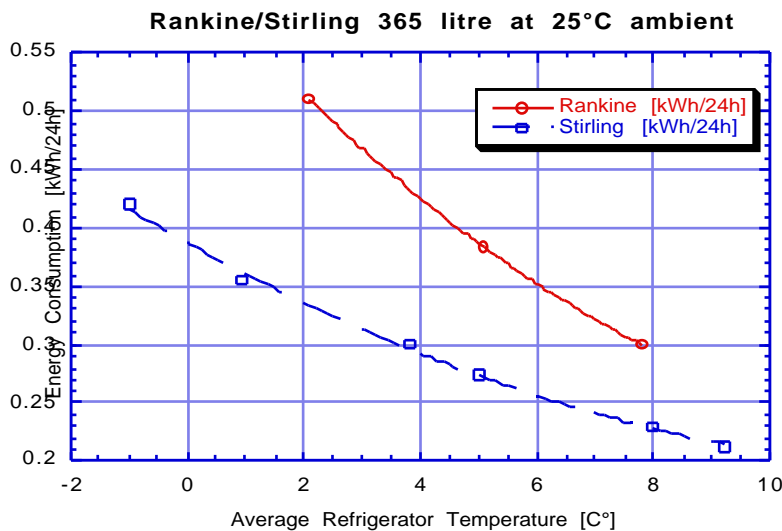

Figure 4 Energy consumption of FPSC Engineering Model installation

Table 1 Some data points - Engineering Model

Number	Cabinet [°C]	Ambient [°C]	Cold T [°C]	Warm T [°C]	Cold head [°C]	Warm head [°C]	Input [W]	Driver [W]	Cooler COP*
51	5.6	25.5	3.2	4.8	2.4	30.3	11.1	1.5	3.06
61	2.3	24.8	4.4	7.3	-2.1	32.1	14.8	1.5	2.61
44	4.9	25.2	3.3	5.2	1.6	30.4	11.9	1.5	2.96

* Cooler COP measured separately.

The test results of the Engineering Model were very encouraging. Based on this, a second Demonstration Model was prepared. This installation would be more representative of a product. Internal custom plastic heat exchangers were vacuum molded. However, owing to cost, the heat exchanger had to be considerably reduced in surface area. Only the back internal wall and the ceiling of the cabinet could be covered with the heat exchanger. The external heat exchanger was a conventional free-convecting unit modified to accommodate a parallel flow path for the heat transfer fluid. Since the cabinet was vacuum insulated, the reduction of heat exchanger surface area was not seen as a significant compromise. The second installation was tested by an independent testing laboratory (Beks and Janssen 1997). The results of these tests showed much higher energy consumption numbers than expected. Some of these results are indicated in Table 2. Comparing Tables 2 and 1, it can be seen that the operating temperatures of the cooling unit were roughly the same at the 5 / 25°C condition. At this condition the cabinet heat leak for the Demonstration Model was measured at 22.6 W. Unfortunately the driver losses were not measured. The drivers have occasionally consumed as high as 3 W but more typically they consume 1.5 W or less. Assuming 1.5 W driver loss, the expected heat lift for the cooler would have been 30.4 W which is almost 8 W more than can be justified from the measurements. The cooling unit was removed from the cabinet and retested. Figure 5 shows the performance of the FPSC after it was removed from the cabinet. Quite clearly it had sustained some damage since there has been significant degeneration in performance. Extrapolating the cooler performance to the 5 / 25 °C point gives only 26% of Carnot or a COP of 2.41. The driver loss was measured at only 0.62 W. So even with the degraded cooler, the lift expected under the test conditions should have been around 26.5 W or about 4 W more than the cabinet heat leak. In a separate heat leak test, some evidence was found for a greater than anticipated heat leak from the installation (Beks and Janssen 1997). The test was unfortunately not sufficiently accurate to verify the magnitude of the additional heat leak. The final test therefore yielded only 4% improvement over the original equipment.

Table 2 Some data points - Demonstration Model

Number	Cabinet [°C]	Ambient [°C]	Cold T [°C]	Warm T [°C]	Cold head [°C]	Warm head [°C]	Input [W]	Driver [W]	Cooler COP*
3	3.6	24.9	4.2	6.2	-0.6	31.1	13.5	?	2.75
5	5	24.9	3.9	5.8	1.1	30.7	12.1	?	2.87
7	7.4	24.9	3.5	5.3	3.9	30.2	10.1	?	3.16

*Expected cooler COP as interpreted from measured data.

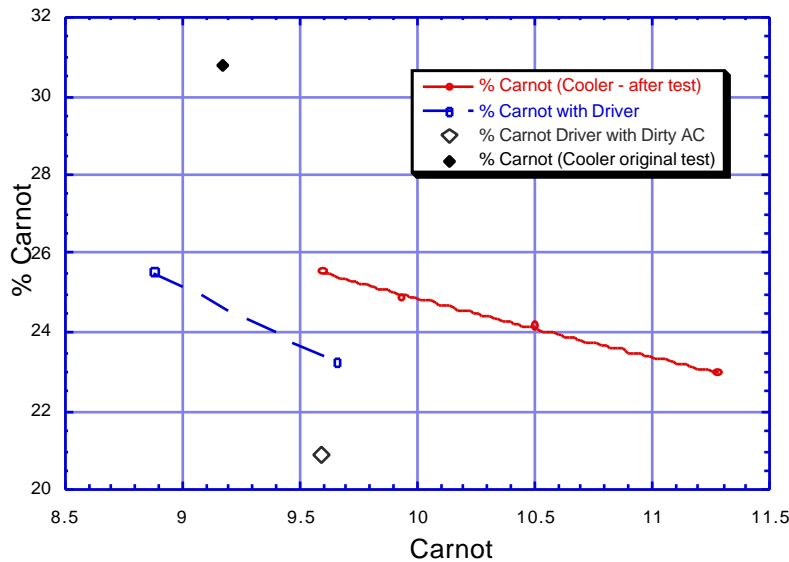

Figure 5 Cooler performance after integration testing

The cooler from the Demonstration Model has been inspected for possible clues as to its performance degradation. So far no clear problems have been identified. Mechanically the unit was found to be in excellent condition. One possible area which has yet to be investigated is the effect on certain components from high temperature operation. This unit was tested to reject temperatures of up to 70°C. In principle the FPSC is capable of performing under extremely high reject temperatures. In the case of the M100A, it may be that certain plastic components used in its construction do not have the required stability at the higher temperatures.

3 POTENTIAL PERFORMANCE

Despite the performance measured on the Demonstration Model, it still appears likely that the FPSC will ultimately obtain extremely high performance levels in well insulated domestic refrigerators. There is further performance optimization possible with these machines and, additionally, the integration technique and methodology will continue to improve. Figure 6 indicates the expected advantage with current generation FPSCs over Rankine for 365 liter one temperature cabinets. As cabinet losses are reduced, the FPSC's advantage will improve. Smaller applications with low average heat leak are expected to benefit substantially. At least two independent efforts appear to confirm this expectation for small freezers (Green *et al* 1996 and Kim *et al* 1997).

Another area in which small FPSCs have a considerable advantage is in size and low overall mass. This advantage tapers off at higher capacities as shown in Figure 7. Portable refrigerators in particular should be able to take advantage of this characteristic since the COP performance is generally well maintained. Based on low capacity testing, it is reasonable to expect that a 30 liter fresh food refrigerator may require less than 5 W average power and that the cooling unit may have a mass of about 0.5 kg.

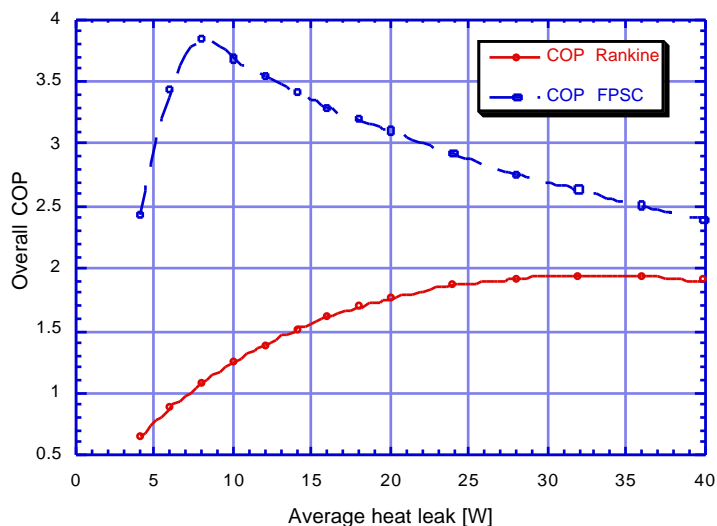

Figure 6 Expected performance advantage over Rankine (5 / 25°C operation)

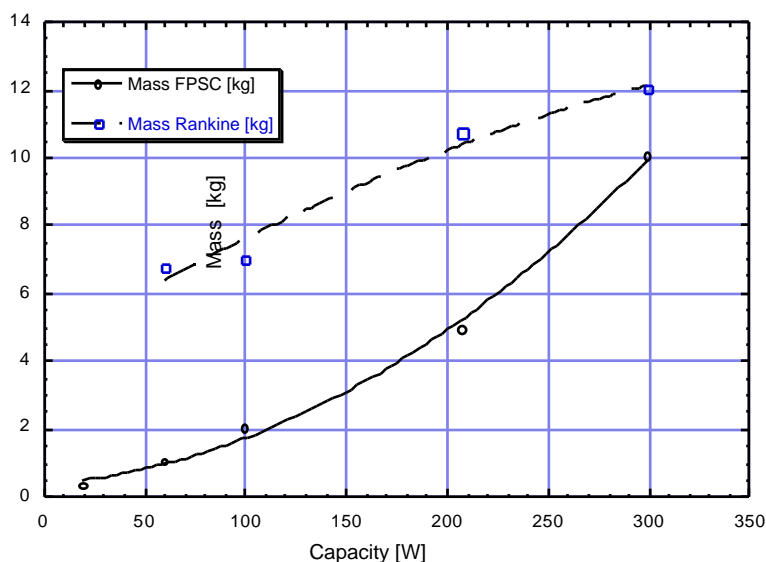

Figure 7 Mass of Rankine compressors and FPSCs.

4 DISCUSSION AND CONCLUSIONS

Comparing the FPSC to Rankine compressors is not a straightforward process. Setting the Stirling warm and cold temperatures equal to the Rankine discharge and suction temperatures for a given capacity does give a complete picture. This technique excludes the significant advantages afforded by the wide capacity modulation of the FPSC. Comparison of complete refrigerator systems is a better way to show the advantages of the FPSC. Calculations for the complete system suggest that the FPSC would have substantial advantages in well insulated cabinets. Tests have verified this expectation. However, a test with a vacuum insulated cabinet produced disappointing results. On closer examination the refrigerator operated as expected from a system view point but owing to a damaged M100A cooler, overall performance was compromised. Nevertheless, evidence continues to accumulate showing the efficiency and other advantages of this technology.

REFERENCES

1. Beks P. and Janssen M., 1997, *Experimental Evaluation of a Stirling Cooling Process on Two Domestic Refrigerators*, Report 97403/GC02, RE/GENT B.V., Eindhoven, The Netherlands.
2. Berchowicz D.M., Kiikka D.E. and Mennink B.D. 1996, *Test Results for Stirling Cycle Cooled Domestic Refrigerators*, IIR Conference - 2nd Int. Conf. on the Use of Non-Artificial Substances, Aarhus, Denmark.
3. Berchowicz D.M. and Bessler W.F., 1993, *Progress on Free-Piston Stirling Coolers*, Proc. 6th. Int. Stirling Engine Conference., Eindhoven, The Netherlands.
4. Berchowicz D.M., 1993, *Free-Piston Rankine Compression and Stirling Cycle Machines for Domestic Refrigeration*, Greenpeace Ozone Safe Conference, Washington D.C.
5. Finkelstein T. and Polonski C., 1959, *Development and Testing of a Stirling Cycle Machine with Characteristics Suitable for Domestic Refrigeration.*, Report W/M(3A).u.5, English Electric Company Ltd., Whetstone.
6. General Electric Corp., 1993, *Electrical Motor-Driven Non-Phase Change Gas Cycle Refrigeration*, Contract 85X-SJ837C, Phase I, GCR System Study and Design, Martin Marietta Energy Systems, Oak Ridge, Tennessee.
7. Green R.H., Bailey P.B., Roberts I. and Davey G., 1996, *The Design and Testing of a Stirling Cycle Domestic Freezer*, Proceedings, IIR Conference -- 2nd Int. Conf. on the Use of Non-Artificial Substances, Aarhus, Denmark.
8. Kim S.-Y., Chung W.-S., Shin D.-K. and Cho K.-S., 1997, *The Application of Stirling Cooler to Refrigeration*, Proceedings, 32nd IECEC, Hawaii, USA.
9. Kirk A., 1874, *On the Mechanical Production of Cold*, Proc. Inst. of Civil Eng., vol. 37, p. 244-315, London.
10. Lundqvist Per G., 1993, *Stirling Cycle Heat Pumps and Refrigerators*, Doctoral Thesis, The Royal Inst. of Technology, Stockholm, Sweden.
11. McDonald K., Berchowicz D.M., Rosenfeld J. and Lindemuth J., 1994, *Stirling Refrigerator for Space Shuttle Experiments*, Proceedings, 29th IECEC, Monterey, California, USA.
12. Mennink B.D. and Berchowicz D.M., 1994, *Development of an Improved Stirling Cooler for Vacuum Super Insulated Fridges with Thermal Store and Photovoltaic Power Source for Industrialized and Developing Countries*, Proceedings, IIR Conference - New Applications of Natural Working Fluids in Refrigeration and Air Conditioning, Hanover, Germany.

PERFORMANCE MAXIMISEE DES REFRIGERATEURS STIRLING A PISTON LIBRE

RESUME: Les performances d'un réfrigérateur Stirling à piston libre (appelée FPSC) avec un caisson à très haute isolation sont examinées. Des conditions d'essai pour le FPSC sont discutées tenant compte des conditions d'opération dans un caisson. On montre que le FPSC peut opérer à grand rendement mêmes à une charge thermique basse. Une évaluation provisoire de la FPSC technologie courante dans des caissons à très haute isolation a produit des résultats incertains à cause d'un bloc réfrigérateur qui a subi une avarie. Cependant, des calculations, fondée sur des bancs essais, se présentent l'avantage de performance sur le système Rankine. Un essai indépendant dans un petit congélateur paraît confirmer cette conclusion.

EXPERIMENTAL EVALUATION OF A SOLAR PV REFRIGERATOR WITH THERMOELECTRIC, STIRLING AND VAPOR COMPRESSION HEAT PUMPS

Michael K. Ewert
NASA Johnson Space Center
Mail Code EC2
2101 NASA Rd. One
Houston, TX 77058

Marty Agrella
Dan DeMonbrun
Oceaneering Space Systems
16665 Space Center Blvd.
Houston, TX 77058

Jim Frahm
Hernandez Engineering, Inc.
17625 El Camino Real, Suite 200
Houston, TX 77058

David J. Bergeron
Space Industries
101 Courageous Dr.
League City, TX 77573

David Berchowitz
Global Cooling Manufacturing
Co.
94 N. Columbus
Athens, OH 45701

ABSTRACT

Solar photovoltaic (PV) refrigeration systems which use batteries have existed for several decades but have only been used in limited applications. Recent technology developments and experimentation in the field are refining the "solar refrigerator." Coupled with the decreasing cost of PV, this is expected to lead to more wide-spread acceptance and use. Keys to the success of the solar refrigerator are a thermally efficient cabinet, thermal storage, and a high-efficiency heat pump. These elements, which are also important for aerospace refrigerators, were combined in a successful demonstration of solar refrigerator technology at the Johnson Space Center. Three heat pump, or "cooler", technologies (thermoelectric, Stirling, and vapor compression) were experimentally evaluated in the same vacuum insulated cabinet. Individual heat pump performance was quantified, and the entire solar refrigerator system was evaluated by defining a system solar COP (coefficient of performance).

1.0 INTRODUCTION

Solar photovoltaic (PV) power system applications are increasing due to both technical and economic factors. Some of the most successful applications for solar energy, such as water heaters and PV water pumping, benefit from built-in energy storage mechanisms. This can be the case with a well designed solar refrigerator which can store "cold" whenever solar energy is available by directly powering the heat pump from a PV panel. While most solar PV refrigerators to date

have used batteries to store electricity, this work focused on the "PV direct" concept and used phase change materials (PCMs) for thermal energy storage. Other technologies that are very beneficial to the solar refrigerator concept are vacuum insulation for the walls of the refrigerator cabinet and high-efficiency heat pumps for cooling.

Solar energy for cooling seems almost paradoxical, but there are actually many ways to accomplish this. NASA and others have studied a variety of solar-powered cooling systems over the years (1). Recent efforts at the Johnson Space Center have focused on photovoltaic (PV) solar heat pumps to provide cooling for a variety of applications. In these applications, a "solar direct" design, in which the PV panel is connected directly to the heat pump, has been emphasized in order to reduce the expense, efficiency loss, and mass associated with intermediate power conditioning and storage devices (2). A dual-use technology project--meaning technology that can be used on earth as well as in space--was started in 1994 to advance solar heat pump technology. As part of that project, three different types of electrically-powered heat pumps were evaluated in a solar refrigerator application. Experimental results of these evaluations are presented below.

The three types of refrigeration systems studied were thermoelectric, Stirling, and vapor compression. These heat pumps were integrated into the same refrigerator cabinet, one at a time, and tested using a fixed-voltage power supply, a PV/battery system, and a direct connection to one or more PV panels. Performance of each of the systems in several different configurations

was quantified. Parameters such as average cabinet temperature, temperature lift, heat pump COP, refrigerator COP, and system solar COP were computed.

Heat pump COP = heat removed by the heat pump cold side [W]/electric power supplied to the heat pump [W]

Refrigerator COP = net heat removed from the refrigerator cabinet [W]/total refrigerator electrical power [W]

System solar COP = net heat energy removed from the refrigerator cabinet [W-hr]/solar energy incident on the PV panel [W-hr]

It can be seen from the above definitions that heat pump COP measures the instantaneous performance of the cooler alone, while the refrigerator COP incorporates any inefficiencies or parasitic loads of the refrigerator. The system solar COP measures the integrated performance of the entire solar refrigerator system over a representative period of time and includes the solar collector efficiency. Thermoelectric testing began in June 1996, Stirling testing began in March 1997, and vapor compression testing began in March 1998.

Since there is considerable current interest in solar refrigerators for commercial applications, NASA has developed some partnerships with private industry in the solar heat pump project. The refrigerator cabinet and thermoelectric heat pump used in this project were developed by Oceaneering Space Systems and loaned to NASA for the project through a Space Act Agreement. The Stirling heat pump was manufactured and loaned to NASA by Global Cooling Manufacturing Company. The vapor compression heat pump was a modified commercial unit manufactured by Sun Frost. Lockheed Martin, Hernandez Engineering, and Space Industries provided technical assistance during the testing under contract to Johnson Space Center.

2.0 SOLAR REFRIGERATOR DESCRIPTION

2.1 Vacuum Insulated Cabinet

To allow solar PV refrigeration to be a viable technology, a highly effective cabinet insulation is required to minimize heat leaks into the cold volume. This solar PV refrigerator used a vacuum panel insulated cabinet conceived and fabricated originally by Oceaneering Space Systems, Marlow Industries, and Owens-Corning for an Advanced Thermoelectric

Refrigerator. In 1993, Oceaneering Space Systems was leading an industry team in the development of a thermoelectric refrigerator/freezer for use on NASA's International Space Station. This refrigerator/freezer incorporated the "state-of-the-art" in thermoelectric cooling systems (provided by Marlow Industries, Inc.), vacuum panel insulation (provided by Owens-Corning) and phase change materials. This development project led the companies to conclude that a thermally efficient "super-insulated" cabinet using environmentally friendly (thermoelectric) cooling and insulation systems, coupled with phase-change thermal storage materials, could be viable in the commercial market. The companies subsequently formed a strategic alliance in 1994 and fabricated two full-size 365 liter (13 cu. ft.) prototypes, one of which was used for these solar PV refrigerator tests.

The cabinet is made from a fiberglass-reinforced plastic with Aura ® vacuum panels sandwiched between the inner and outer shells. The door, floor, and walls all contain Aura ® vacuum panels. The top part of the cabinet is insulated with foam and was designed to house a thermoelectric cooler and allow for air heat exchange. Subsequently, this part of the cabinet was used to house the Stirling and vapor compression coolers. The cabinet originally contained an interior false back wall that provided a channel for air flow from the bottom of the cabinet up to the thermoelectric heat exchanger and a space to hide the phase change material.

Great care was taken during the design and fabrication of the cabinet to minimize direct heat leaks between the exterior surface of the cabinet and the interior cold volume. The door, for example, has a unique bezel interface with the cabinet to minimize conductance and convection through the door seal. The resulting thermal insulation performance of the cabinet has been outstanding. The heat leak across the super-insulated cabinet walls and door seal for a 21°C temperature difference was measured to be 20 watts using an ice melt test. This translates to a composite R value of 26. Most conventional commercial refrigerators have a composite R value of approximately 5.

2.2 Thermoelectric Heat Pump

The thermoelectric heat pump used in this test incorporates Peltier effect thermoelectric cooling modules consisting of 6 assemblies, each containing 71 doped Bismuth-Telluride couples. These modules are assembled using aluminum oxide ceramic face plates

which have been metallized with copper as a conductor, nickel as a diffusion barrier, and lastly, low temperature indium alloy solder to provide bonding between the nickel and the thermoelectric elements. When assembled, alternating "N" and "P" doped pellets are arranged in a series string such that all P-N junctions are on a common face and all N-P junctions are on the opposite face. Current passing through such a series assembly transports heat from one face to the other. The direction of heat flow is dependent on the polarity of the current.

All modules within the heat pump were wired in a series string, giving a total of 6 x 71 or 426 couples. Power from an external source (solar, battery, or lab power supply) was controlled by a simple series-pass transistor which applied either the full available power when the temperature was above the control set point, or a minimum forward bias current to prevent the back flow of heat from the hot side after the set point was satisfied. A solid-state sensor located in the air stream just forward of the cold side heat exchanger provided feedback to establish the control state of the pass transistor.

Heat pumped out of the cold volume was accepted by a stacked fin aluminum heat exchanger which was incorporated into a forced convection air loop containing a fan within the cabinet. Heat then passed through the thermoelectric heat pump into the hot side heat exchanger, a high-efficiency vacuum brazed folded fin assembly which was cooled by room air and three fans. To conserve power and reduce active heating within the enclosure, the internal fan was speed controlled to provide maximum air flow only when the heat pump was operating at maximum capacity.

Optimization methods employed in this heat pump include the utilization of a large number of modules / couples as compared to a conventional (cost-sensitive) heat pump design. The advantage is achieved both in the efficiency of the Peltier devices, and in the improved heat spreading and temperature uniformity of the hot and cold heat exchangers. The subject heat exchangers were designed to provide significantly more than minimum surface area to further improve performance.

2.3 Stirling Heat Pump

The Stirling cycle alternately compresses a fixed mass of gas (usually helium, which was used here) at one temperature level and expands it at another in a closed regenerative cycle to either pump heat or do work (3,4).

The thermodynamic cycle, in its ideal form, has the highest possible efficiency of any thermodynamic cycle. In the case of a heat pump, the efficiency of the cycle is typically defined by the COP, the ideal form being:

$$COP_{Carnot} = \frac{T_c}{T_h - T_c} \quad (1)$$

where COP_{Carnot} is the Carnot COP, T_c is the cold side temperature in Kelvin, and T_h is the hot side temperature in Kelvin.

In practical machines, the Carnot COP can only be approached. The degree of closeness to perfection is measured by the percentage achieved of the Carnot COP. Figure 1 shows some data taken from a number of M100A model Stirling machines. As the temperature span increases, the fraction of Carnot COP improves (to a point). For single temperature refrigerators operating in the fresh food regime in a moderate 25°C ambient, the best fraction of Carnot so far achieved has been about 30 to 34%. At a point corresponding to the ASHRAE test point for compressor systems, the percentage of Carnot so far achieved is closer to 45%.

The particular Stirling device used here is based on the free-piston principle (5). This configuration avoids many difficulties associated with past Stirling machines. In particular, oil lubrication and gas leakage are completely avoided by the use of gas bearings and hermetic sealing. The free-piston Stirling is driven by a linear motor operating at, or close to, resonance. Gas pressures are used to drive the second moving part (the displacer), so no mechanical linkages are required.

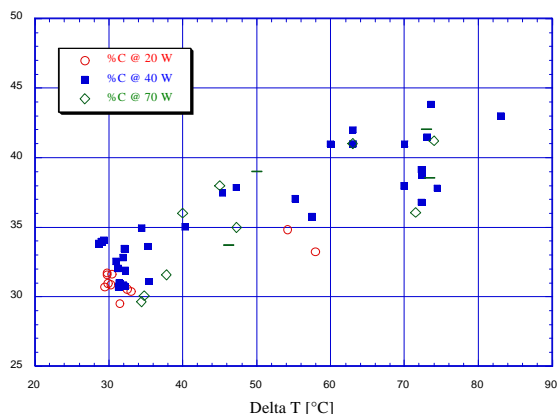

Fig. 1 Percentage of Carnot COP versus temperature lift for Stirling heat pump

The advantages offered by the free-piston Stirling heat pump are simple capacity modulation by adjusting the drive voltage, high reliability and long life owing to gas bearings, potential for quiet operation when machine vibration is correctly isolated, small size, high COP at low capacity, low starting currents and no environmentally damaging chemicals.

The electronic control device developed for the free-piston Stirling takes advantage of these attributes by controlling the power to the cooler based on both cold side temperature and available power from the PV panel. Since heat pump COP is almost constant over most of the capacity range for given hot side and cold side temperatures, the input power is close to being directly proportional to capacity. This characteristic is used as a means to control the load on the PV panel so that maximum power is captured under almost any condition of solar insolation. This type of peak power tracking is a first for solar refrigerators (6,7).

A particular difficulty facing the integration of Stirling coolers into refrigerator cabinets is associated with the means of transferring the heat at the cold and hot sides. The Stirling itself has relatively high heat fluxes at its heat rejector and acceptor. A thermal transformer of sorts is required for the effective integration of the cooler into a cabinet. In this particular arrangement, the Stirling was equipped with a forced air heat rejection system consisting of peripheral fins around the hot end and a small DC fan to force air over them. The cold side was equipped with a first generation resonant pump activated by residual casing vibrations causing a water/propylene glycol solution to circulate between the Stirling cold end and the ice thermal storage heat exchanger in the cabinet. This vibration reduced COP and capacity but it worked well and eliminated the need for a separate, electrically powered pump. Improvements to the resonant pump have already been made over the one tested.

2.4 Vapor Compression Heat Pump

Vapor compression systems currently dominate the refrigerator and freezer market due to three main reasons: the compressors have a manufacturing cost of less than \$100, they typically operate for up to 20 years without failure, and modern high efficiency units can achieve COPs of about 2 for typical refrigerator/freezer applications and as high as 3 for a 'refrigerator only' configuration. Very small capacity units achieve lower COPs.

However, driving a compressor directly with solar power presents a number of system problems which result in inefficient use of the available solar energy unless corrective measures are taken. The goal of such a system is to efficiently vary the capacity of the compressor to match available solar power. The solution chosen for this investigation was to use a variable speed DC compressor with electronics which control the compressor speed to match the available solar power. Additionally, large input capacitors were used to level out the motor current draw during rotor rotation and to provide adequate starting current for the compressor. The system was designed to operate when the solar input was as low as about 40% of full power. This is estimated to capture about 90% of the available solar energy on sunny days.

The system employed a recently developed Danfoss ® BD35F direct current compressor with refrigerant 134a. The compressor speed could vary from 2000 to 3500 rpm. The system used a capillary tube, a forced air convection condenser, and a refrigerant-to-water/propylene glycol heat exchanger for the evaporator. The water/glycol mixture was circulated through the thermal storage heat exchanger within the cabinet as in the Stirling test.

2.5 Phase Change Thermal Storage

The phase change material (PCM) used in the thermoelectric and initial Stirling tests was Norpar 15 (NP15-ABS), an n-paraffinic hydrocarbon reported to have a phase change temperature of 7 °C (45°F). The PCM was encased in flexible urethane-coated Nylon bags and mounted behind the false wall of the cabinet, with heat transfer being provided by air flowing over these bags. The total mass of PCM in the cabinet was 3869 grams (8.5 lbs). Latent heat of the PCM was measured to be 26 cal/gm (46 BTU/lb) compared to 35-37 cal/gm (63-67 BTU/lb) reported by the manufacturer. Using the measured value, the total thermal storage capacity of the NP15 PCM was expected to be 117 W-hrs (399 BTU).

During the Stirling testing, the NP-15 PCM was removed from the refrigerator and replaced with a larger capacity ice thermal storage heat exchanger manufactured by AIL Research, Inc. The ice thermal storage heat exchanger is a 0.343 m by 1.22 m by 0.083 m (13 ½ in. by 48 in. by 3 ¼ in.) container which holds 24.6 liters (6.5 gallons) of water. In this case, heat exchange out of the thermal store is via a liquid coolant which flows into headers at one side and

through three plastic plate heat exchangers to headers on the other side. These plate heat exchangers form the front, back, and center partition of the container, which holds pure water. Refrigerator cabinet air rises on four sides of this ice storage container transferring heat to it by natural convection. The total thermal storage capacity of the ice PCM was expected to be 2289 W-hrs (7810 BTU).

2.6 Solar panels

Solar power was generated by Solarex ® MSX-120 semi-crystalline silicon PV panels which are rated at 120 watts each. Measured panel efficiency averaged 10%. In different tests, ½, 1, 2, and 3 panels were used. The solar panels faced 25° west of south and were tilted at 10° from horizontal at latitude 30°N. Two Deka Solar ® 12 volt DC gelled electrolyte batteries (Model 8G8D) with a capacity of 6360 W-hrs and a voltage regulator were used in some tests. In the PV direct tests, the voltage regulator and batteries were bypassed.

3.0 TEST DESCRIPTION

Testing of the thermoelectric and Stirling refrigerators was conducted in laboratory building 241 at the Johnson Space Center inside a small enclosure which could be temperature controlled at or above room temperature. Prior to the vapor compression refrigerator test, the entire set up was moved to building 7. Different input voltages were tested for each refrigerator using a laboratory power supply to achieve steady state test points. The thermoelectric refrigerator was tested first without, then with, the NP15 PCM. Solar tests were conducted with and without batteries after the PCM was installed. Initial tests with the Stirling refrigerator used the NP15 PCM, liquid pumps on the hot and cold sides and an air-to-water/glycerin heat exchanger on the cold side. Subsequently, the ice thermal storage heat exchanger was installed and testing continued. During this time period, the Stirling refrigerator was operated using one PV panel in both PV direct mode and with batteries. Power consumption was high due to the liquid pumps and unacceptable heat gain in the liquid lines above the cabinet; therefore, the thermal store could not be charged in the PV direct mode and the batteries were soon discharged in the battery mode. A new Stirling heat pump was then integrated into the cabinet using a resonant pump and water/propylene glycol loop on the cold side and a heat pump-to-air heat exchanger with

fan on the hot side. Performance results from this configuration are presented below. PV/battery testing could not be completed before the move, but PV direct and steady state results are discussed. Integration of the vapor compression heat pump was accomplished after the move, and steady state tests were performed, but solar data was not available at the time of this writing. However, proper operation in the solar direct mode was verified by the manufacturer prior to delivery to NASA.

4.0 THERMOELECTRIC TEST RESULTS

The thermoelectric solar refrigerator was tested with all three power sources: laboratory power supply, PV/battery, and PV direct. The data shown in Figure 2 was generated from different voltage steady state power supply points. Ambient temperature ranged from 23 to 25°C. Lower voltage test points corresponded to lower capacities and thus lower lift temperatures since no sophisticated power conditioning was used. Heat pump and refrigerator COP increased at lower temperature lifts as expected. The difference between the heat pump and refrigerator COP data results from imperfect heat transfer on the hot and cold sides and from parasitic fan power included in the refrigerator COP. Temperature lift is measured from air-to-air for the refrigerator and from hot side-to-cold side for the heat pump alone. An air-to-air temperature difference of about 20°C is required to make an effective refrigerator, so it can be seen that further improvements in heat transfer would result in great improvements in COP. Maximum air-to-air temperature lift for the refrigerator design tested was found to be 23°C at the maximum capacity of 22 watts of cooling.

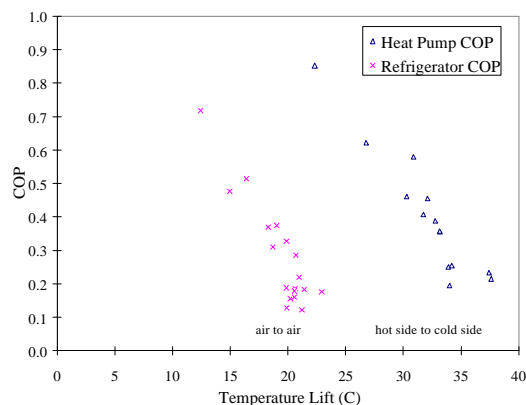

Fig. 2: Thermoelectric heat pump COP and refrigerator COP versus temperature lift

The refrigerator was operated using the PV/battery system described above with different numbers of 120 watt PV panels in 12 and 24-volt configurations. At 24 volts, the desired setpoint of 3 °C was maintained in a 27 °C ambient for a few days, but this required an average power of over 100 watts, which eventually drained the batteries, even with three PV panels connected. At 12 volts, the thermoelectric heat pump allowed a cabinet setpoint of about 8 °C to be maintained and required an average power of just over 30 watts. At this level, operation was sustainable with three, and just barely with two, 120 watt panels, but not with one. The system solar COP (defined in the Introduction) was found to be 0.049 for the two PV panel/battery thermoelectric solar refrigerator configuration. Calculated average PV panel efficiency was 9.3% for this case.

The thermoelectric refrigerator was operated in the PV direct mode at 12 V with one panel. The cabinet never got cold enough to freeze the Norpar-15 thermal store so a constant temperature could not be maintained overnight. Minimum cabinet temperature was 9°C and the average was 18°C. The system solar COP was 0.039 and the calculated average PV panel efficiency was 8.1%. The intersection of the PV panel voltage-current curve and the thermoelectric heat pump load line was somewhat above peak power voltage, so adding another panel in parallel would not help much since most of the added current capacity would go unused. Adding another panel in series would make the voltage, and thus power consumption, too high. It would be necessary to redesign the thermoelectric heat pump or add a voltage converter to make use of extra power in the PV direct configuration.

5.0 STIRLING TEST RESULTS

The Stirling solar refrigerator described above was tested using the power supply and directly connected to a PV panel. Using the power supply, the refrigerator was able to maintain an internal temperature of 5°C using as little as 12 watts of power. An earlier, less efficient configuration was tested using one 12-volt PV panel and the two batteries, but they were discharged within 4 days.

From the steady state power supply test points at both refrigerator and freezer conditions, the data in Figure 3 was calculated for heat pump and refrigerator COP versus temperature lift. Ambient temperature ranged from 23 to 28°C. Again, temperature lift is measured from air-to-air for the refrigerator and from hot side-to-

cold side for the heat pump alone. COP is less sensitive to temperature lift than for the thermoelectric heat pump. It is believed that the true heat pump COP was higher than the graph indicates because the heat pump also removed any heat which was gained in the cold water/glycol lines running to and from the cabinet. Line heat gain could not be quantified in this test, but based on earlier tests, is believed to be significant. Maximum air-to-air temperature lift tested was 33°C and colder temperatures would have been possible. Maximum heat pump capacity was about 100 watts.

Figure 4 shows data from a 6 day period with the Stirling solar refrigerator directly connected to one PV panel without batteries. The 24.6 liters of water in the cabinet provided thermal storage, but never froze due to the limited capacity of the heat pump and the short winter days. The system solar COP was 0.09. The power profile shows that the 120 watt PV panel was under utilized on sunny days. When run with a half PV panel, average refrigerator temperature went up to 14°C, but the system solar COP improved to 0.14.

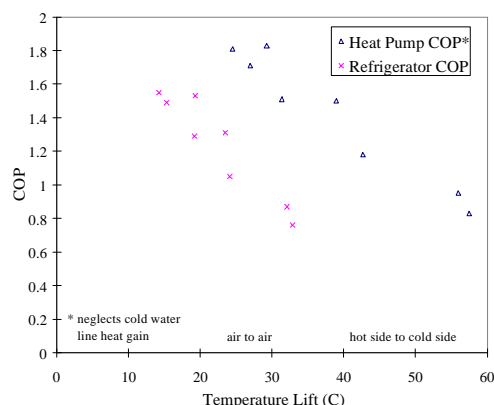

Fig. 3: Stirling heat pump COP and refrigerator COP versus temperature lift

Though the ice thermal store could not be frozen using intermittent solar power alone, the concept was validated by running the Stirling refrigerator with the power supply until the ice was completely frozen and then turning off the power. The cabinet air temperature remained below 5°C for 4 days. In order to utilize the ice thermal store properly with PV direct power, a larger capacity heat pump will be required.

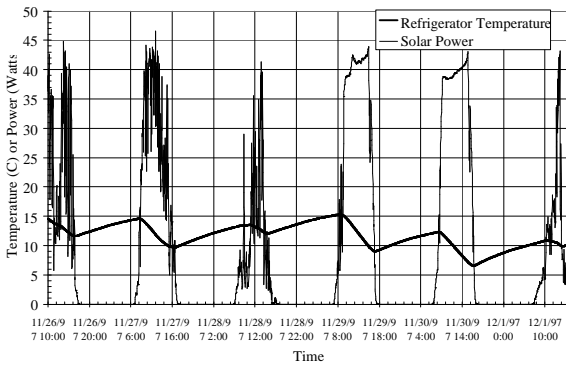

Fig. 4: Stirling Solar Refrigerator Performance

6.0 VAPOR COMPRESSION TEST RESULTS

The vapor compression solar refrigerator was operated with a DC power supply set at 15 volts, bypassing the automatic speed control based on PV panel output. The data in Figure 5 shows reasonably good heat pump and refrigerator COPs, with some room for improvement. In particular, the evaporator-to-cold water/glycol loop temperature difference was quite high and the use of a capillary tube instead of an expansion valve caused flooding or starvation of the evaporator at many operating points. Ambient air temperature ranged from 25 to 26°C for the data points shown. Temperature lift is measured from air-to-air for the refrigerator and from evaporator inlet to condenser surface for the heat pump alone. COP was fairly sensitive to temperature lift.

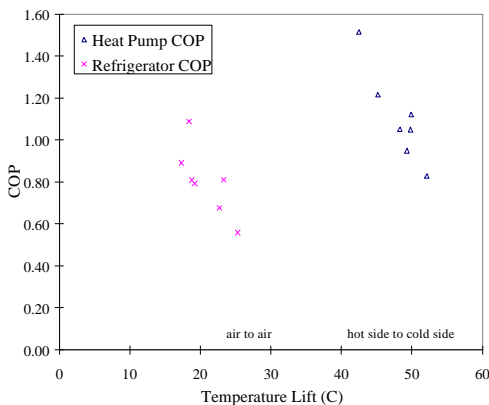

Fig. 5: Vapor compression heat pump COP and refrigerator COP versus temperature lift

7.0 CONCLUSION

The feasibility of a “PV direct” solar refrigerator using vacuum insulation and thermal storage has been demonstrated using 3 different types of heat pumps. Initial performance measurements have been obtained and preliminary comparisons made. Further testing is required to determine the optimum design for each type of refrigerator and to make final comparisons between the 3 PV direct systems and PV/battery systems.

The thermoelectric solar refrigerator had the advantage of simplicity since DC power from the PV panel could directly power the thermoelectric heat pump. However, the thermoelectric system solar COP was only 0.04 due to the relatively low COP of the thermoelectric modules at the required temperature lift conditions. The Stirling solar refrigerator had a system solar COP as high as 0.14 but the pumped fluid loop used to improve heat transfer on the cold end resulted in some system losses. The vapor compression solar refrigerator had a good refrigerator COP, but system solar COP data was not available in time for this paper.

In order for a solar refrigerator to maintain the proper temperature throughout the year, close attention will have to be paid to the capacities of the heat pump, PV panel, and thermal store for a given cabinet size and insulation. It is expected that a PV direct heat pump with a capacity of 200 watts or more will be required for the “20 watt” refrigerator cabinet described here in order to account for short winter days and clouds.

While high heat pump COP is important, certain types of heat pumps may be easier to integrate, resulting in higher refrigerator COPs. For example, it may be possible to eliminate an intermediate cold air or liquid loop with the vapor compression system and build the ice thermal store directly on the evaporator. Electrical interaction of a given heat pump with the PV panel may be better than another resulting in a higher system solar COP. Although the ultimate solar refrigerator configuration is still developing, these issues are being addressed and good progress has been made. Of course, cost will also be a large factor in the commercial success of solar refrigerators, but that subject is beyond the scope of this paper. The conclusion here is that several good design options exist; however, proper sizing of components and good system integration are essential.

8.0 REFERENCES

- (1) Ewert, Michael K., Terrestrial and Aerospace Solar Heat Pump Development: Past, Present and Future, ASME paper at Solar '98, Albuquerque, NM, June 1998
- (2) Ewert, Michael K., et al, Conceptual Design of a Solar Powered Heat Pump for Lunar Base Thermal Control System, SAE paper # 961535, 26th ICES, July 1996
- (3) Walker, G., *Cryocoolers* , New York: Plenum Press, 1983
- (4) Berchowitz, D. M., Miniature Stirling Coolers, NEPCON - East '93, Boston, MA, June, 1993.
- (5) Beale, W. T., Free-Piston Stirling Engines - Some Model Tests and Simulations, SAE Cong., Detroit, MI, Jan 13-17, 1969. Also SAE paper 690230
- (6) Mennink, B. D. and Berchowitz, D. M., Development of an Improved Stirling Cooler for Vacuum Super Insulated Fridges with Thermal Store and Photovoltaic Power Source for Industrialized and Developing Countries, International Institute of Refrigeration Conference, Hannover, May 1994
- (7) Berchowitz, D. M., Stirling Coolers for Solar Refrigerators, International Appliance Technical Conference, Purdue University, May 1996

THE APPLICATION OF STIRLING COOLER TO REFRIGERATION

Seon-Young Kim, Woo-Suk Chung, Dong-Koo Shin, Kwan-Shik Cho
LG Electronics Inc., Living System Lab.
327-23, Gasan-Dong, Keumchun-Gu
Seoul, 152-023
Korea
Tel) +82-2-818-7944, Fax) +82-2-867-3941

ABSTRACT

The application field of the free-piston Stirling Cooler, Model 100A of Global Cooling BV in the refrigeration has been studied. The cooling effectiveness of the free-piston Stirling Cooler which means small capacity with better efficiency, large range of temperature and capacity modulated operation is of much use to cool a space insulated well. One practicable application is suggested here, in which FPSC and secondary heat transfer fluid are used to the single temperature refrigerator (60 liter) instead of conventional vapor compression machines. In the freezer operation at -20°C inside cabinet, the steady-state test results show 25% improvement in energy consumption over original one. The application of free-piston Stirling Cooler to a freezer at lower temperature shows great potentials also.

INTRODUCTION

In the domestic refrigerator market the needs for freezers are increasing these days. It's well known that the reservation of food in the lower temperature ($<-30^{\circ}\text{C}$) is much more useful to keep food fresh for the longer time. However current freezers maintain around -20°C inside cabinet and it's not easy to reach the lower temperature using conventional vapor compression machines. Due to the application of double-stage compressor for the low temperature area (-30°C or lower temperature), the price of the conventional installations is rising (Lange, 1993).

Stirling cycle has lots of advantages in the freezer application; Large range of temperature, good efficiency for a large capacity range and capacity modulation operation. The free-piston Stirling cooler (FPSC), particularly, has compactness, long life time and high efficiency (Berchowitz, 1993). The application of FPSC to refrigeration is progressed by companies and laboratories. Global Cooling BV is a leading company in this field. A 200 liter solar powered refrigerator for FPSC to be installed shows the possibility as an efficient mains power unit and a 365 liter domestic refrigerator with FPSC equipped (around 0°C) shows 30% energy saving over the original Rankine unit (Berchowitz,

1996).

Since 1996, LG Electronics has joined the evaluation program of GC BV. In the program the possibility of commercialization of FPSC has been studied and the application field has been searched. One possible application is a freezer at lower temperature than conventional one.

A 60 liter FPSC refrigerator has been set up with the new refrigeration cycle system replacing the original one. This new system is made up of a FPSC, inner heat exchanger and a pump. The secondary heat transfer fluid, ethanol, carries cold heat from cold end to the heat exchanger (the original evaporator) inside the cabinet. This can eliminate the major disadvantage of FPSC, the small area of heat transfer. A fan cools the warm end of FPSC, which makes the system simple. This freezer is modulated by the FPSC controller and the various operation mode can be achieved. It is tested in the freezer operation mode and compared with the original one. The test results show 25% improvement in the energy consumption and good possibility of this application.

FREE-PISTON STIRLING COOLER (FPSC)

The FPSC, Model 100A, is a recent product of Global Cooling BV. Its cooling capacity is 100W at 0°C (cold end)/ 30°C (warm end) and COP is 1.3-1.4 at ASHRAE condition, -23.3°C (cold end)/ 54.4°C (warm end). The total length is under 250mm and the mass is 2.5kg. The input voltage is 200-270 VAC. The operation is controlled easily according to the value of the variable resistance in the small driver electronics. As the switch turns on, the FPSC operates fully until its cold end temperature reach the fixed one and modulates its cooling capacity continuously with minimum energy consumption.

The FPSC consists of expansion/compression space, regenerator and motor part. Copper cap is weld on each of the surface of expansion and compression spaces, which forms the cold and warm ends. The cold end (expansion space) is at a distance of the length of the regenerator space from the warm end (compression space) and the motor body is close to the warm end. Therefore the insulation plate can be placed easily between the cold end and the warm end.

In fig.1 all parts of FPSC system are shown. Two heat exchangers (HEX), doughnut shape, are mounted on the side surface of the cold/warm ends coated with thermal grease to accept and reject heat by thermal contact. The cold end HEX has inlet/outlet ports for fluid on the surface and copper fins inside to improve heat transfer to the cold end from the fluid. The warm end HEX has double-stage corrugated copper fin welded on its surface. The balance spring is installed at a projecting Helium port beneath the motor body and makes the vibration of itself to diminish the vibration of the FPSC.



FIG.1 ALL PARTS OF FPSC SYSTEM UNASSEMBLED

The motor body and warm end is inserted into the shell which is designed for a cover plate to isolate the cold end from the warm end and for air to flow inside. A DC cooling fan mounted on the opposite open end blows air into the shell to pass by the warm end HEX through the path. The cold end is projected from the shell cover plate and wrapped with insulation.

FPSC REFRIGERATOR

The 60 liter single temperature refrigerator is selected because its volume and insulation is suitable for the FPSC to operate at the freezer mode and its side box is large enough for the new system to be mounted easily as shown in fig. 2. This refrigerator is a commercial product sold well though it isn't a model for high efficiency. Due to its various running mode with temperature setting (-20~5°C) and compactness, it can be used conveniently. It consists of a chest type cabinet in which an evaporator is covering the inner side wall and the side box in which a compressor and a condenser coil are installed. The evaporator is made up of two plates pressed and tube circuit between them. It is connected to the compressor and condenser through inlet /outlet tubes

It isn't hard to remove the compressor and condenser by cutting the inlet/outlet tubes of the evaporator. After the refrigerant and oil are cleaned away the new refrigeration system is mounted in the side box and connected to the original evaporator through the Swagelok tube fittings. The



FIG.2 A FPSC REFRIGERATOR (60 LITER).

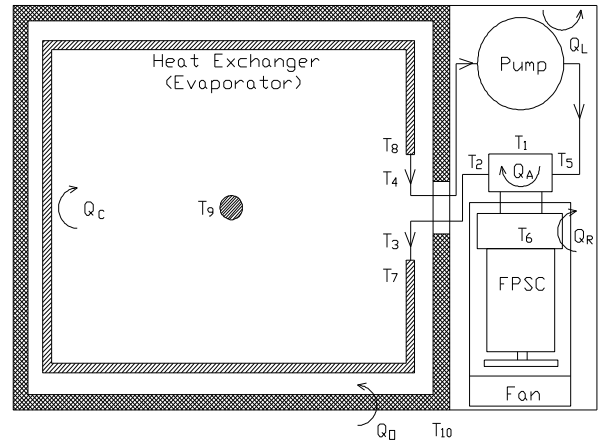

FIG.3 SCHEMATIC DIAGRAM OF A FPSC REFRIGERATOR.

flow sensor, Model FTB601 (OMEGA), is installed in the tube line to measure the flow rate of the secondary heat transfer fluid. Tubes and fittings are insulated with urethane pipe. The pump head is also insulated with urethane foam but the motor body of the pump is not insulated so that motor heat can be rejected. The FPSC inserted to the shell is placed in the front of the side box horizontally and the pump is placed in the rear vertically as shown in fig. 3. The cold end HEX is insulated with urethane tape and the inlet/outlet ports are placed up and down for the fluid to flow upward.

Ethanol is selected as the secondary heat transfer fluid because its freezing point is low enough to be cooled to very low temperature maintaining its viscosity relatively low. The DC water pump is used to make ethanol carry the cold heat into the cabinet.

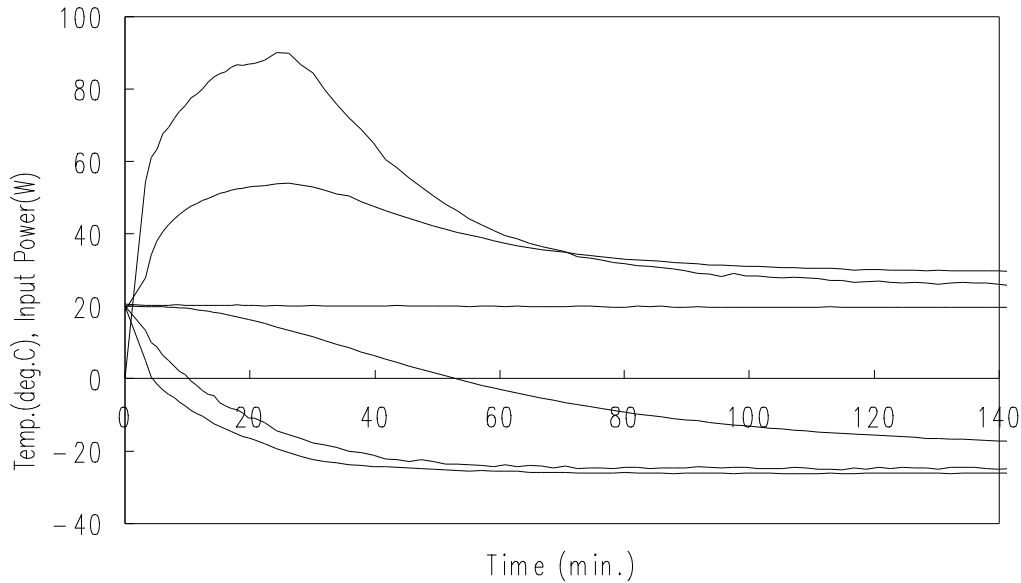

FIG. 4 TEST RESULT OF FPSC REFRIGERATOR OPERATION (20°C AMBIENT)

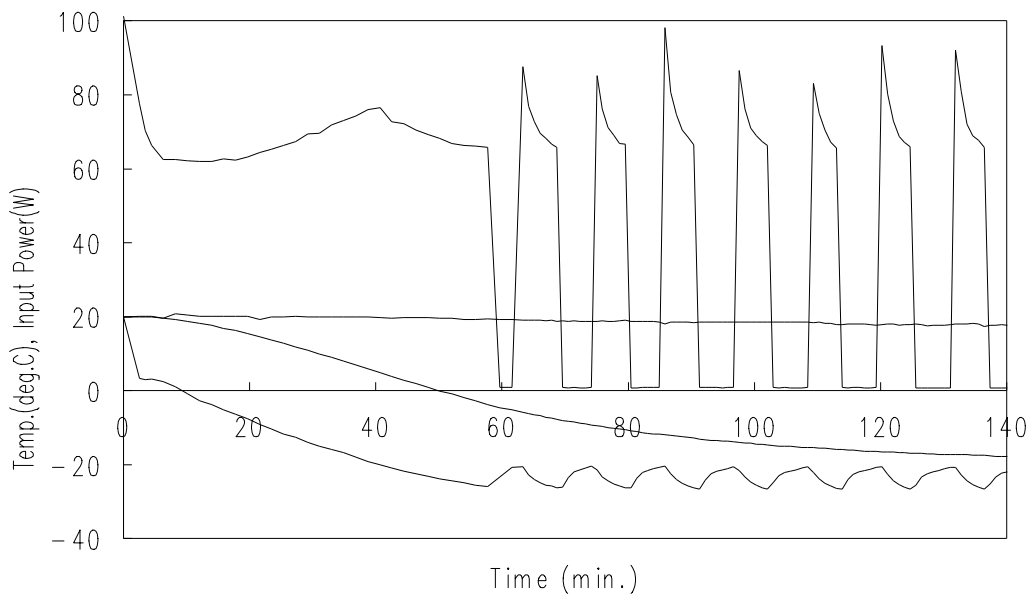

FIG. 5 TEST RESULT OF ORIGINAL REFRIGERATOR OPERATION (20°C AMBIENT)

TEST RESULTS

The test results of both refrigerators in the freezer operation are shown in Fig. 4 and 5. In the original refrigerator the cabinet temperature goes down a little faster and the power consumption is a little higher. At the steady state the original refrigerator controls its operation by power on/off but the FPSC operates continuously. In table 1 the comparison of energy consumption at the steady state is listed. The FPSC refrigerator shows 25% improvement over the original one.

TABLE 1. ENERGY CONSUMPTION AND NOISE LEVEL COMPARISON AT -20°C/20°C (NOISE LEVEL IS MEASURED AT A DISTANCE OF 20cm FROM THE

SIDE BOX)

Refrigerator type	Power (W)	Consumption(k Wh/24h)	Noise dB(A)
FPSC set	25.7	0.689	60
Pump	1.6		
Fan	1.4		
Rankine	-	0.869	55

TABLE 2. HEAT LIFT AND LOSS AT -20°C/20°C (W)

Cold End	Cabinet	Loss
29.8	21.7	8.1

The noise level of FPSC is higher than the original one due to the vibration of the FPSC body and balance spring. In the starting the irregular vibration and noise take place for one or two minutes and it seems due to the simple motor control. However those problems can be overcome by adding vibration absorber and the improvement of the controller

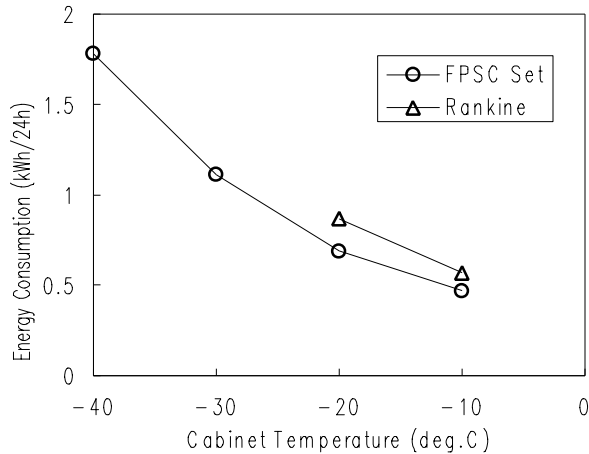

FIG. 6 ENERGY CONSUMPTION AT VARIOUS OPERATION MODE

The heat lift in the cold end and the cabinet inside can be calculated from the temperature difference, the flow rate of ethanol and specific heats and they are shown in table 2. The loss is due to the heat inflow through the pump motor without insulation. COP (heat lift/input power) of the FPSC is 1.04 but it is lower than the performance test results of GC BV (COP, 1.4) under the same condition of the cold/warm end temperature.

The energy consumption of the FPSC set and the original

Rankine cycle at various operation mode (fig. 6) shows that the application of FPSC to the freezer has the potentials. However some problems remain still in the FPSC system and the secondary heat transfer fluid. In this commercial insulation standards the FPSC should have more cooling capacity to be used in the wide application fields and the more effective way of heat transfer should be developed because most of the commercial secondary heat transfer fluid has very high viscosity in the cold temperature region and alcoholic liquid is dangerous even though it has relatively low viscosity in the region.

CONCLUSION

The test results show that the free-piston Stirling Cooler refrigerator has great potentials and better efficiency than the original one which is a commercial product sold well though it is not well optimized for high efficiency. However most of the refrigerator makers may hesitate to apply this new refrigeration system to their products because it is a replacing technology not a leading technology. So the new rising market should be searched. The freezer is a good example, in which the FPSC has much more advantages than the vapor compression cycle. Therefore, if the better insulation is developed and the cooling capacity of FPSC is increased, the commercialization will be sooner.

REFERENCES

- Berchowitz, D. M. and Bessler, W. F., 1993, "Progress on free-piston Stirling coolers", Proc. of 6th ISEC, pp. 341-346
- Berchowitz, D. M., Kiikka, D. E. and Mennink, B. D., 1996., "Test results for Stirling cycle cooled domestic refrigerators", IIR Conference, the Aarhus, the Denmark
- Lange, Th. J. de, and Vries, M. J. de, 1993, "The application of the Stirling cycle to refrigeration machines: A design methodological analysis", Proc. of 6th ISEC, pp. 285-290

RECENT ADVANCES IN STIRLING CYCLE REFRIGERATION

D.M.BERCHOWITZ*, D. KIIKKA* and B.D.MENNINK

Global Cooling BV
The Netherlands

*Also Sunpower Inc
Athens, Ohio, USA

INTRODUCTION

Over the past few years research has been undertaken to investigate the suitability of the free-piston Stirling cycle for domestic refrigeration /1, 2, 3/. This work has been motivated by the potential of environmental attractiveness and low cost of the Stirling unit. In November 1993, a Dutch consortium of environmental groups, utilities and government energy research agencies funded a demonstration project to build a Stirling cooled, solar powered, battery-free super efficient refrigerator /4/. No-sun operation was provided for by a thermal store. Figure 1 shows the demonstration project refrigerator with the door open to reveal the thermal store while Figure 2 shows the small free-piston Stirling specifically developed for the project. The results of this effort were extremely encouraging. One of the more striking attributes to be shown by the study is the ability of the free-piston Stirling to maintain high efficiencies at low lifts. A COP of better than 2.0 (0 to 30°C) over lift from 8 to 50 W was achieved. This confirmed the idea that the free-piston Stirling would be an ideal choice for supplying the small cooling capacities required by super insulated cabinets now under development. The program described here extends the original program to further investigate possibilities of performance improvement in the Stirling unit and the potential of the Stirling / vacuum super insulated (VSI) cabinet combination. Strong emphasis continues to be placed on solar operation with the aim to demonstrate an environmentally friendly photovoltaic refrigerator of about 270 l with an energy consumption of around 50 kWh / yr.

The Stirling cycle is fundamentally different to that used in conventional refrigerators (the Rankine cycle). Helium is employed as the working medium and no phase change occurs. The particular unit described here is a free-piston machine driven by a linear motor /1/. All internal running surfaces are supported by gas bearings so that during steady operation no contact wear takes place. The entire unit is hermetically sealed and dynamically balanced for low noise and vibration. Operational characteristics include the fact that the lift (capacity) is easily modulated since the piston amplitude is directly proportional to the drive voltage. More complete technical and theoretical descriptions are contained in /1, 5/. Suffice it to say that in its ideal form, the Stirling cycle has the highest obtainable efficiency of any cooling device.

The VSI technology used for this study is that developed by L. Schilf (Vacutherm GmbH - Germany). This technology has the advantage of being completely recyclable and having been tested in the form of insulated wall panels and commercial steam pipes. In both applications, the reliability has been excellent. Aside from the low heat loss, VSI cabinets have a better ratio of storage to outside volume compared to conventional refrigerators. The vacuum insulated cabinets have been designed by the Swiss Foundation Ökokühlschrank.

Integration of the Stirling unit is different to the way compressors are integrated into conventional refrigerators. Heat transfer to and from the cooler must be arranged by secondary media. The original demonstrator used conduction to transfer the cabinet load to the cold head, while the warm side heat transfer was augmented by a small 1.4 W fan. The current project will employ different techniques to the demonstrator project. However, these techniques are not covered in this presentation.

Six example installations are presently being pursued, namely:

- a) Two single temperature refrigerators of 270 litres, one solar powered and the other mains powered.
- b) Two two-temperature refrigerators of 220 litres fresh food and 30 litres freezer. Again, one solar and the other mains.

- c) Two solar cool boxes of 40 litres powered by a removable photovoltaic panel in the lid.

DEMOfRIDGE PHOTO

DEMO MINICOOLER PHOTO

Figure 1 The demonstration fridge
(cabinet supplied by Foron GmbH)

Figure 2 The demonstration Minicooler

THE SYSTEM

The basic system consists of:

- a) a free-piston Stirling cooler capable of high performance over a turn-down ratio of 10:1. Target COP is 3.0 for 0 to 30°C.
- b) a super insulated cabinet with extremely low static heat leaks. Target heat leak is 8 W to both the freezer and fresh food section for the two temperature cabinet.
- c) a heat transport system capable of heat transfer with high effectiveness and low parasitics.
- d) an optional electronic control system capable of being directly connected to a small photovoltaic panel. Consumption has been budgeted at 1 W or less.
- e) an optional thermal store capable of storing thermal potential in order to avoid the use of storage batteries. Store should provide enough potential for 24 hrs of no electrical input.

FREE PISTON STIRLING COOLING UNIT (MINICOOLER)

Using data obtained from the two demonstrator units and other hardware run at refrigerator conditions, the calculation and design procedure was carefully calibrated. This activity has greatly improved the confidence with which performance may be predicted. A COP in excess of 3.0 appears to be practical for 0 to 30°C for lifts up to 60 W. Figure 3 shows the predicted and measured performance of the original demonstration unit. A COP of around 2.0 was obtained with a square wave driver. On mains the COP was about 2.2. Also shown is the predicted performance for the current project (labeled Opt.). An important feature clearly evident from Figure 3 is the uniformity of the COP over a wide range of input. This is a characteristic of the free-piston Stirling that is not seen in other practical thermodynamic cycles. Additionally, since there is essentially a complete absence of starting torque, no high currents are required. The ability, therefore, exists to provide useful cooling with extremely small amounts of energy which greatly improves the practicality of using photovoltaic panels without battery back-up.

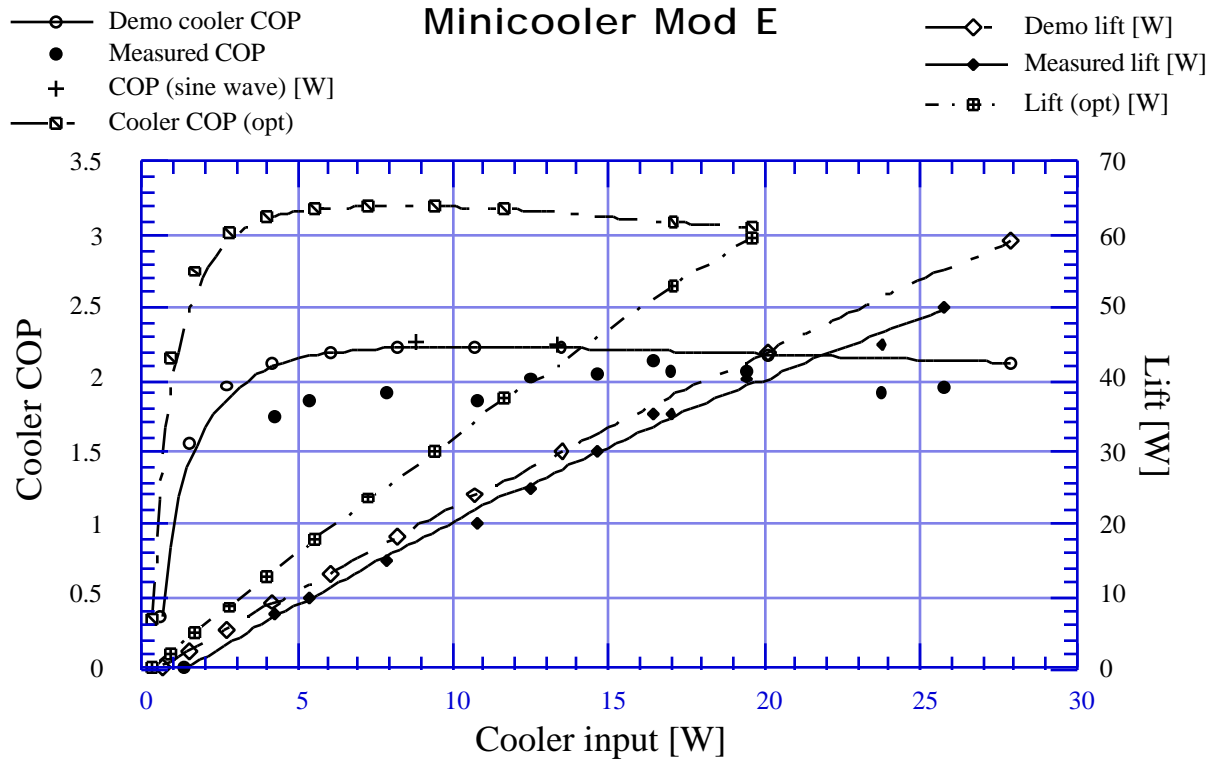

Figure 3 Performance of demonstrator and predicted performance of optimized unit (0 to 30°C)
 Data marked • is obtained using DC square wave driver
 Data marked + is obtained using mains (AC sine wave)

Another important feature of the free-piston Stirling is its ability to operate over a wide range of design optimum with relatively small penalty. An example of this is shown in Figure 4. Here the sensitivity of the cycle is shown by plotting the COP against the reject temperature. High ambient temperatures are common in many parts of the world, and can result in reject temperatures in excess of 50°C for the VSI / Stirling configuration. Table 1 shows that the temperature sensitivity of the Stirling compares favorably to the Rankine for operation around the design point. For conventional refrigerators high temperature ambients impose serious penalties. This manifests in the form of increasingly high pressure ratios which result in higher friction loads. Cascading degradation of performance then occurs since as COP declines the load on the heat exchangers increases further causing even higher reject temperatures.

Cycle	COP / COP [%]	
	Cold side	Warm side
Rankine /6/	4%	3%
Stirling	3%	2%

Table 1: Temperature sensitivity around design point

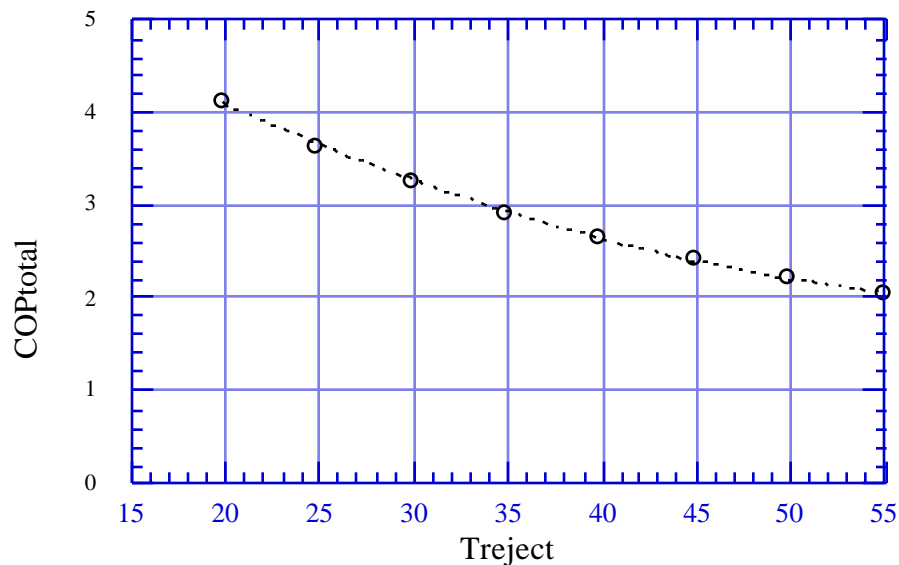

Figure 4 Sensitivity to reject temperature (calculated)

A test rig has been constructed and well instrumented in order to investigate and optimize the thermodynamics and mechanical details of the Minicooler (Figure 5). Many mechanism and cycle losses may be directly or indirectly measured. Mechanism losses include losses associated with gas bearings, hysteresis, windage, centering and motor inefficiency. Cycle losses are the internal irreversibilities associated with the actual cycle. Figure 6 shows an example of mechanism and cycle losses as measured on the test rig. The mechanism loss is expected to be some 50% less in the final unit.

An important purpose of the test rig is to empirically parameterise the design in those aspects that are intractable by other means. The optimization approach, therefore, involves a close coupling of analytical and empirical procedures. By this method, the confidence in achieving design goals is greatly magnified.

At the time of writing, only limited operational data has been taken. This is shown in Table 2. As can be seen, the measured COP is between 2.7 and 2.8 for these tests (a fraction of Carnot of about 30%). It is expected that when parasitics unique to the test rig are removed, the objective COP will be achieved at about 35% Carnot. In any event, the current test rig performance is excellent for a small lift device. Also shown is one point for -25°C to 28°C . The COP here is 1.59 which at 34.3% is a higher fraction of Carnot than the 0 to 30°C points. The $\text{COP}_{\text{adjust}}$ column is the estimated COP at the design condition based on the achieved fraction of Carnot.

Once optimum parameters are verified with the test rig, the Minicoolers will be fabricated for installation into the VSI cabinets. The estimated final overall dimensions of the new Minicooler which is shown in Figure 7 will not change much by this process.

PHOTO TEST RIG

Figure 5 The test rig

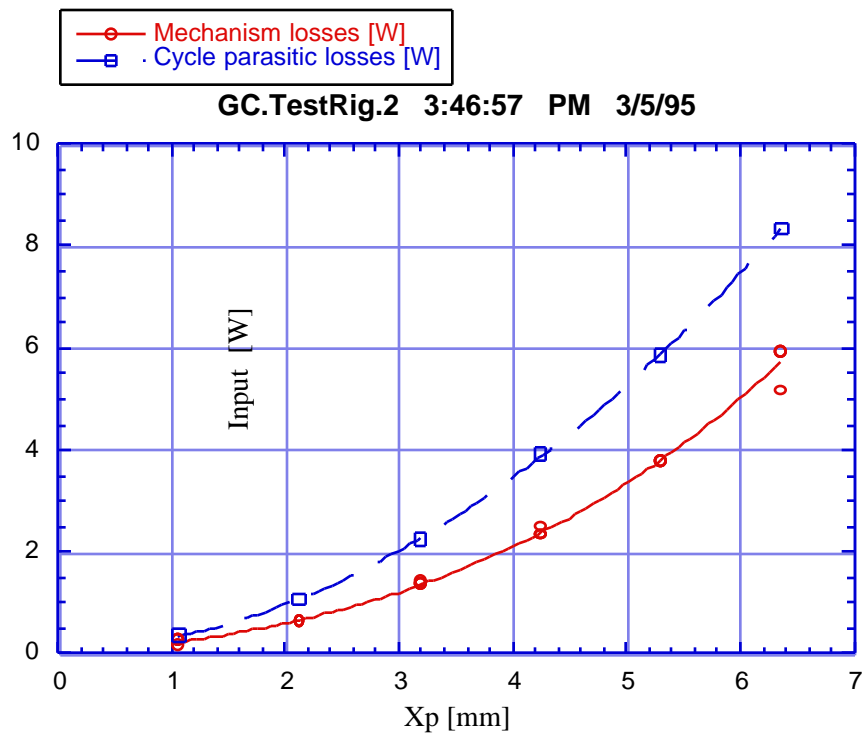

Figure 6 Mechanism and cycle parasitic losses measured on test rig

Cold side [°C]	Warm side [°C]	Input [W]	Lift [W]	COP	Carnot %	COP _{adjust}
0.2	32.5	13.50	33.93	2.51	29.7	2.70
-1.7	31.6	21.79	54.60	2.51	30.8	2.80
-0.7	29.3	7.12	19.30	2.71	29.9	2.72
-1.0	28.2	3.11	7.06	2.27	24.4	2.22
-0.6	33.2	14.14	35.90	2.54	31.5	2.87
-1.1	29.6	17.22	45.4	2.64	29.8	2.71
-0.8	29.6	9.70	26.49	2.73	30.5	2.78

-1.5	29.1	4.25	9.96	2.34	26.4	2.40
-25.3	28.2	12.70	20.16	1.59	34.3	1.62*

Table 1: Data from test rig

*Design condition here: -23°C to 30°C

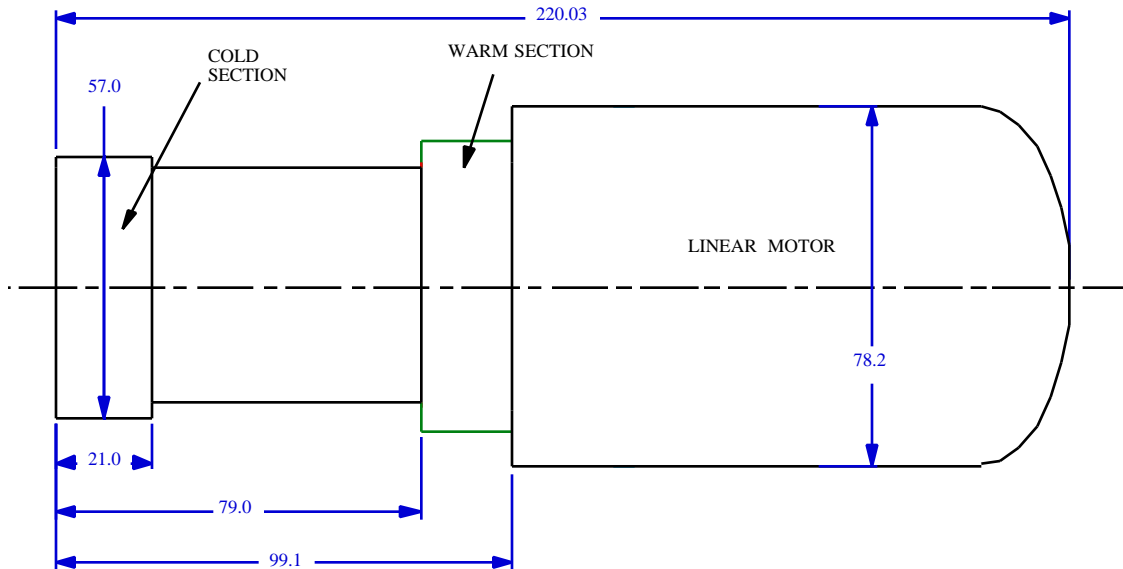

Figure 7 Overall size of new Minicooler (total mass: 2.3 kg)

THE TEST CABINETS

The cabinets are of the following sizes:

- 1) One temperature cabinet: 270 l
- 2) Two temperature cabinet: 220 l for fresh food and 30 l for the freezer. The freezer is a separate vacuum insulated box that inserts into the basic fridge cabinet.
- 3) Solar cool boxes: 40 l.

Each cabinet consists of an outer and inner stainless steel box with the interstitial space filled with diatomaceous earth under a hard vacuum. The edges of the two boxes are joined with a thin membrane structure in order to keep conduction losses to a minimum and maintain the integrity of the vacuum. The wall thickness is around 2.6 cm for the fridges and slide-in VSI freezer box and about 1 cm for the solar cool boxes. There is only one small hole in the box for the exit of the rejected heat and the power lines. Since the heat rejection of the Minicooler is highly localized, it is possible to install the Minicooler within the cabinet and route the rejected heat to the outside of the cabinet. This results in much lower transmitted noise levels, significantly larger useful fridge volume and lower cabinet fabrication costs. Figure 8 shows schematically the overall size and intended location of the Minicooler in the two temperature fridge cabinet. Heat leakage for the two temperature cabinet is expected to be 8 W for each of the two spaces (the freezer and fresh food sections) for a total of 16 W. For the single temperature cabinet, the heat leak is expected to be about 14 W. The solar cool boxes, with wall thicknesses of 1 cm, will have a heat leak of probably around 6 W. Heat leak numbers are specified at 25°C ambient.

PREDICTED SYSTEM PERFORMANCE

In order to achieve a yearly energy consumption of 50 kWh for the single temperature 270 l fridge, the average consumption should be about 5.7 W. Using a 25°C ambient test point the transmission loss for this fridge is expected to be about 14 W. A COP of 3.0 would require 4.7 W average input to the cooler leaving about 1 W for the electronic controls and heat transfer system. For the mains unit it may be possible to reduce control parasitics to even less than 1 W.

The integration of the Minicooler into the two-temperature fridge is especially interesting. The system will be configured in such a way so that the Minicooler only cools one space at a time. By so doing, it is possible to maximize the overall COP. Therefore, for the fresh food compartment the COP would be around 3.0 and for the freezer around 1.8. This translates into a net average energy consumption, inclusive of electronic controls, of around 8 W or about 70 kWh per year.

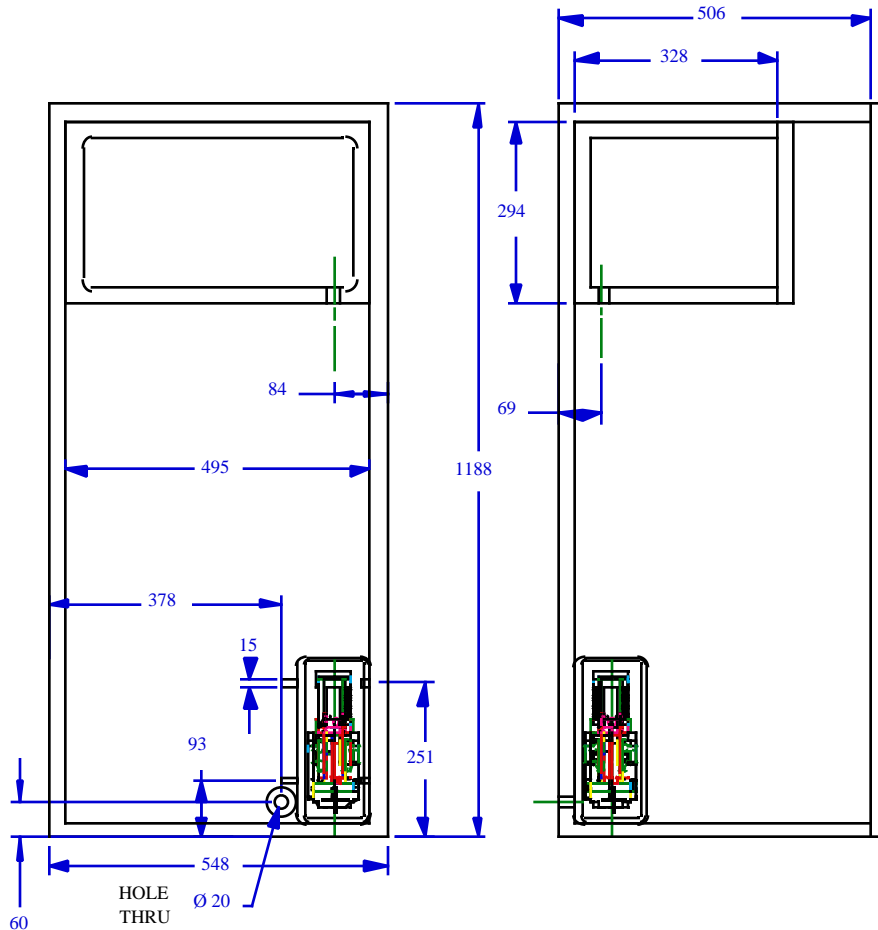

Figure 8 Two-temperature fridge showing intended location of Minicooler

Since the solar cool boxes have a static heat load of about 6 W, the total heat removal will have to be at least 12 W in order to adequately charge the thermal store. Average input to the Minicooler will then be about 4 W. However, it will be the installed peak capacity together with the instantaneous solar power that will determine actual lift. With a 12 W_{peak} panel on a sunny day it is estimated that between 9 AM and 1:15 PM, the solar power varies between 6 and 12 W in Northern latitudes. This would result in lifts ranging between 18 and 36 W which is enough to charge the 24 hr thermal store. In conditions where less than 6 W is available, the Minicooler will continue to lift substantial heat, even down to 2 W input where the COP would be about 2.0.

The details of the thermal stores are not included here. A functional description of the thermal store as used in the demonstrator fridge is contained in /4/.

CONCLUSIONS

The use of the free-piston Stirling cooler together with VSI cabinets offers an outstanding opportunity to provide an environmentally friendly refrigerator of remarkably low energy consumption. Excellent performance can be expected in moderate, tropical and hot climates. Both the original demonstration project and the data obtained so far from the test rig strongly endorses

the predicted performance of the cooler. The ability of the free-piston Stirling cooler to make useful cooling with extremely low inputs while maintaining high COPs is an important characteristic for direct photovoltaic operation without the need for storage batteries.

SUMMARY

Environmental concerns have created a need for domestic refrigeration equipment that do not use Chlorofluorocarbon (CFC), Hydrochlorofluorocarbon (HCFC) and Hydrofluorocarbon (HFC) compounds and operate at much higher efficiencies than current equipment. Specifically addressed in this paper is the potential of Stirling cycle cooled VSI fridges. The performance characteristics are particularly suitable for direct photovoltaic operation without the need for storage batteries. Optimization has been carried out on small Stirling coolers for lifts less than 70 W. Analysis and test results indicate that COP's of 3.0 are possible for one temperature refrigerators under standard conditions. The steady improvement in COP over the last few years for this type of device is discussed. Current COP's are better than any known alternative cycle for similar low lift conditions. Energy consumption figures have been determined showing that for the particular case of a one-temperature, 270 l VSI refrigerator, less than 50 kWh / yr is completely reasonable.

REFERENCES

- /1/ D. M. Berchowitz and R. Unger. "Experimental Performance of a Free-Piston Stirling Cycle Cooler for Non-CFC Domestic Refrigeration Applications", XVIII International Congress of Refrigeration, Montréal, Canada, August 1991, pp 848-852.
- /2/ W. F. Bessler. *Electrical Motor-Driven Non-Phase Change Gas-Cycle Refrigeration; Phase I: GCR System Study and Design*, Final report, Contract 85X-SJ837C, U. S. Dept of Energy (also General Electric Corp., June 1993).
- /3/ G.Chen. *Free-Piston Gas Cycle Refrigeration for Medical Units: Technical Feasibility Investigation through Demonstration and Testing of a Laboratory Prototype*, SBIR Phase I, Sunpower Inc., March 1994.
- /4/ B.D.Mennink and D.M.Berchowitz. "Development of an Improved Stirling Cooler for Vacuum Super Insulated Fridges with Thermal Store and Photovoltaic Power Source for Industrialized and Developing Countries", International Institute of Refrigeration Conference - New Applications of Natural Working Fluids in Refrigeration and Air Conditioning, Hannover, Germany, May 1994.
- /5/ D. M. Berchowitz. "Free-Piston Stirling Coolers", International Refrigeration Conference - Energy Efficiency and New Refrigerants, Purdue University, July 1992.
- /6/ Gulbrandsen *et al.* *Development of Energy Efficient Electrical Household Appliances, Part One: Refrigerators*, Technical University of Denmark, Final Report for DG-XVII of the Commission of the European Communities, 1986.

STIRLING COOLERS FOR SOLAR REFRIGERATORS

D.M.Berchowitz [*]

Global Cooling BV
Coehoornsingel 76
7201 AE Zutphen, The Netherlands
Tel: +31 -575-542933
Fax: +31 -575-542944

Presented at the International Appliance Technical Conference,
May 13-15, 1996, Purdue University, West Lafayette, IN.
Reproduced with permission.

[*] Also at Sunpower, Athens, OH 45701 USA

ABSTRACT

Further optimization has been carried out on small Stirling coolers for use in super insulated cabinets. The specific application addressed here is solar powered refrigeration for off-grid operation and is a continuation of a project first demonstrated in principle in 1994. Overall COP's of close to 3.0 are expected for fresh food preservation temperatures and ambients of 25°C. Extremes of ambient have far less deleterious effect on performance than for current refrigeration systems. This is particularly advantageous in tropical areas and other high ambient temperature conditions. A small batch of optimized units has been fabricated and tested, both in situ and on the bench. Measured COP's are better than any known cycle for similar low lift conditions. Two refrigerator configurations have been studied, (i) a 365 litre (13 cu.ft.) one temperature kitchen unit. and (ii) a small 30 litre (1 cu.ft.) portable cool box. Smart electronics and a thermal store allow the system to maximize the usage of available insolation and therefore minimize the required size of solar panel. The kitchen unit would require one 60 W_{peak} panel for northern European climates. while the cool box is expected to use an integrated solar panel of about 20 W_{peak}. No storage batteries are used. Emphasis has been placed on the use of recyclable materials and components, high efficiency and environmental friendliness. Long life and high reliability are ensured by the use of non-contact gas bearings.

BACKGROUND

Photovoltaic (solar) panels have a high initial cost per Watt of useful power (around \$5 to \$6 per peak Watt). This generally provides a major impediment to photovoltaics for energy intensive applications. Typical domestic refrigerators require upwards of 30 W average power with start-up surges an order of magnitude higher. In order to run such a system on photovoltaics, something near three hundred installed Watts would be required in addition to batteries (for surge and night-time operation). Furthermore, an inverter would usually be needed since most refrigerators have been designed for mains operation. All of this implies a very high cost and periodic up keep since batteries do not last more than about 1500 charge / discharge cycles. Practical photovoltaic powered refrigerators would have to require far less power than conventional refrigerators and would preferably be able to store cooling potential without resorting to batteries. These requirements imply (a) high operating efficiency for the cooling unit, (b) greatly improved thermal insulation for the cabinet and (c) a reliable means to store cooling potential for no-sun operation.

In November 1993, a Dutch consortium of environmental groups and utilities funded a demonstration project to build a Stirling cooled, solar powered, battery-free super efficient refrigerator [1]. No-sun operation was provided for by a cold store consisting essentially of water ice. In April 1994 this unit was demonstrated at the 12th European Photovoltaic Conference. One of the more important attributes to be shown by this initial study is the ability of the free-piston Stirling to maintain high efficiencies at low lifts. A cooler COP of better than 2.0 over lift from 8 to 50 W was achieved (0 to 30°C). This suggested that the free-piston Stirling would be an ideal choice for supplying the small lifts required by super insulated cabinets. Since the completion of the demonstration project, the Stirling unit has been further improved to a COP closer to 3.0 for the design point (0 to 30°C) and the maximum capacity has been increased to better than 90 W. This unit is considered to be an ideal candidate for solar powered refrigeration.

FREE-PISTON STIRLING COOLER AND ELECTRONIC DRIVER

The Stirling cycle employs a small quantity of helium as its working medium. No phase changes occur during the cycle and therefore all heat transfer takes place over a finite temperature differential. The particular unit described here is a free-piston machine driven by a linear motor (Figure 1) [2,3]. All internal running surfaces are supported by gas bearings so that during steady operation no contact wear takes place. The entire unit is hermetically sealed to a leak rate of about 10^{-9} std cc/s. An AC voltage source drives the unit and operational characteristics are such that the lift (or capacity) are easily modulated since the piston amplitude is directly proportional to the RMS drive voltage. Operation is incipient at any application of voltage so there are no high starting currents.

An important feature for this application is the ability of the free-piston Stirling to operate over a wide range of the design optimum while still maintaining high performance levels. This is shown in Figure 2 for different lifts of 20 W, 40 W and 70 W. The design point Carnot COP is 9.1 for which the actual COP is close to 3.0. This corresponds very closely to the operating conditions for a one-temperature refrigerator operating in a 25°C ambient. The Stirling is equally comfortable operating at the ASHRAE condition where the COP is roughly 1.3 to 1.4.

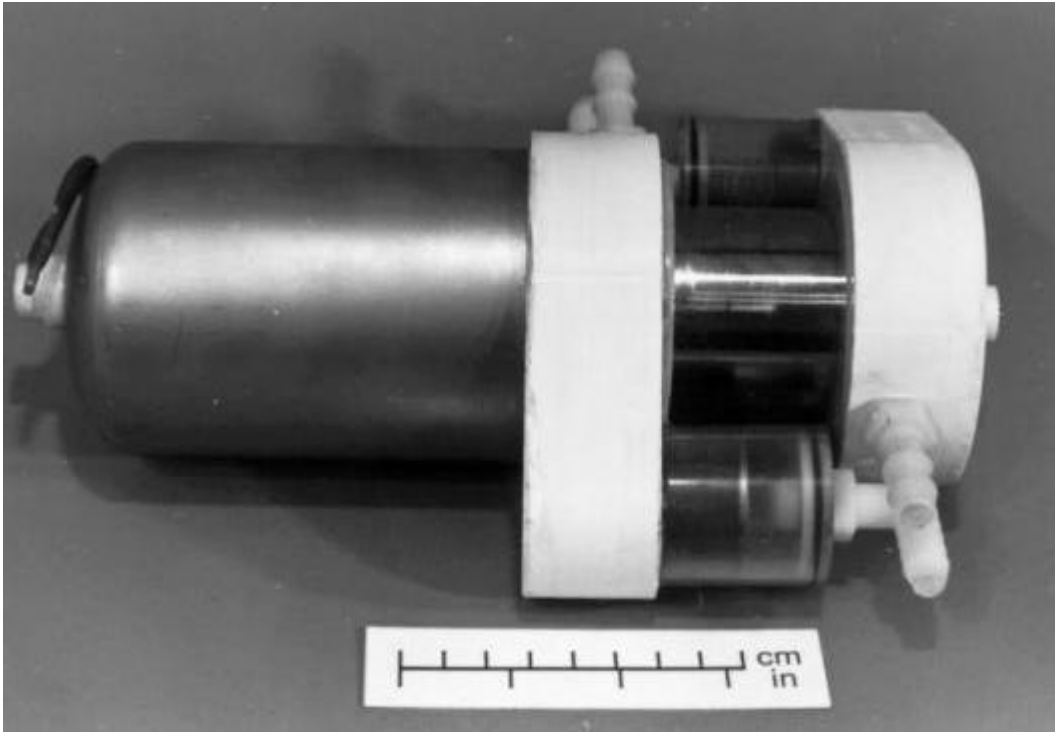

Figure 1 Free-piston Stirling with inertia pumps (mass about 2.5 kg)

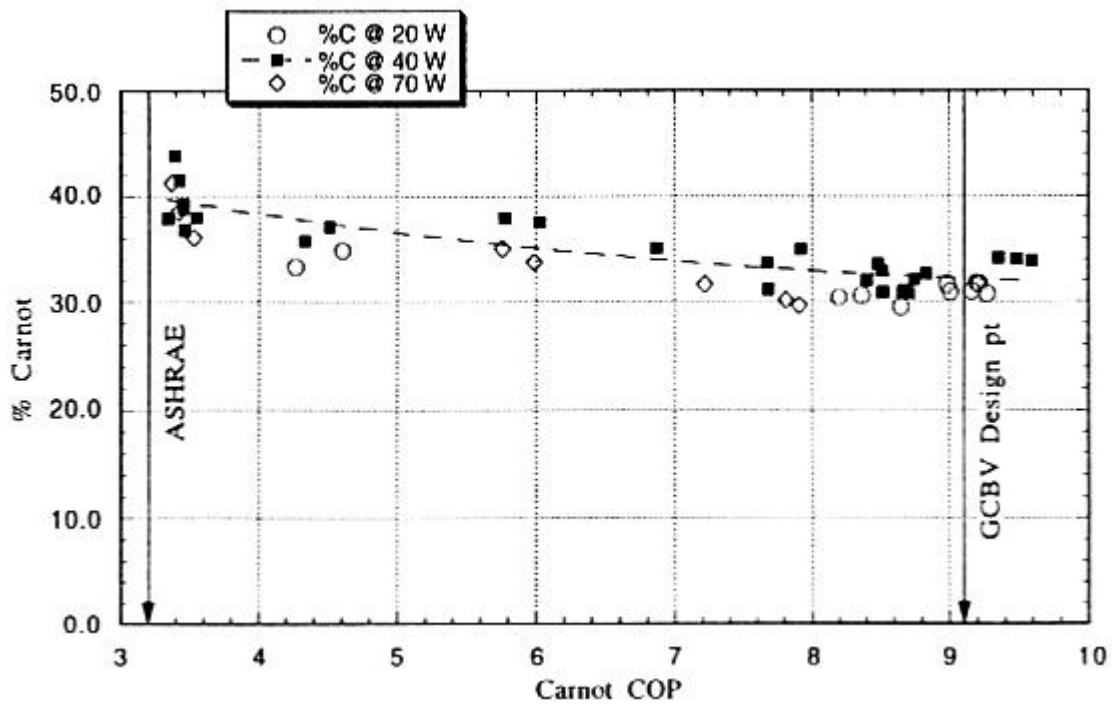

Figure 2 Performance of free-piston cooler (Carnot COP = $T_{cold}/(T_{warm} - T_{cold})$)

Since solar panels are DC devices, it is necessary to convert the DC to AC power. This is done with a small converter which is integrated with the cooling modulation circuit and is referred to as the electronic driver. This electronic driver ensures that the cooler never over cools the cabinet by reducing the RMS drive voltage in response to an error signal derived from a user set temperature.

Additionally, since the cooler may be modulated, the electronic driver contains logic that enables it to alter the input to the cooler so as to load the panel at its optimum operating point. This allows maximum power capture by the panel and is sometimes referred to as peak power tracking. The combination of peak power tracking and the characteristic of the free-piston Stirling of maintaining high COPs over a wide range of lift modulation results in a high utilisation efficiency for the panel. Therefore, even at low levels of insolation, say 5 W or less, the system is still capable to performing useful cooling.

CABINET DESIGN

In order to maximize the cooling potential of the available power, it is necessary to maximize the insulation quality of the cabinet. The energy required by a refrigerator may be attributed some 75 to 90% to the thermal performance of the insulated cabinet [5]. Door openings and insertion of food are usually of less importance. This even holds for very well insulated refrigerators [6]. Table 1 shows the distribution of thermal loads for two foam insulated one-temperature European refrigerators, namely the GRAM models K 215 and LER 200. The thermal loads are for standard (25°C) and normal (21°C) conditions. Normal conditions include door openings, Qd (24 / day) and insertion of food Qf (4 kg / day). Qtr is the insulation loss. This table confirms the potential for energy savings by further improvements to the insulation. Unfortunately, further increasing the thickness of the walls is often considered to result in unacceptably compromised internal volumes.

TABLE 1 Reduction of thermal load by better insulation

	K 215		LER 200	
Insulation:	Cabinet: 3 cm, Door: 2 cm		Cabinet: 6.5 cm, Door: 7 cm	
	Normal	Standard	Normal	Standard
Qtr	23.3 W (81%)	29.1 W	13.2 W (71%)	16.5 W
Qd	2.2 W (8%)	-	2.2 W (12%)	-
Qf	3.1 W (11%)	-	3.1 W (17%)	-
Total	28.6 W	29.1 W	18.5 W	16.5 W
COP	0.94	0.83	1.56	1.41
Appliance const.		1.46 W / K		0.83 W / K

One method to improve insulation without sacrificing internal volume is by using vacuum insulation panels (VIP). Two developments which show promise are silica powder filled plastic panels (Degussa) and stainless steel foil covered fiberglass panels (Owens Corning). The thermal conductivity of the silica panel is 6 to 8 mW / m K while the fiberglass panel is 1.5 mW / m K at the center and an average of 2.4 mW / m K for 75 X 75 cm panels. For comparison, polyurethane foam is around 24 mW / m K. Recently, Greenpeace investigated the effect of progressively thicker VIPs using a thermal conductivity of 2.9 mW / m K [7]. Figure 3 shows the results of this study from which the enormous potential of VIPs is evident. For the same thickness of insulation for the base-case model (3 cm), the energy consumption drops from 300 kWh / yr to 50 kWh / yr without any other design improvements.

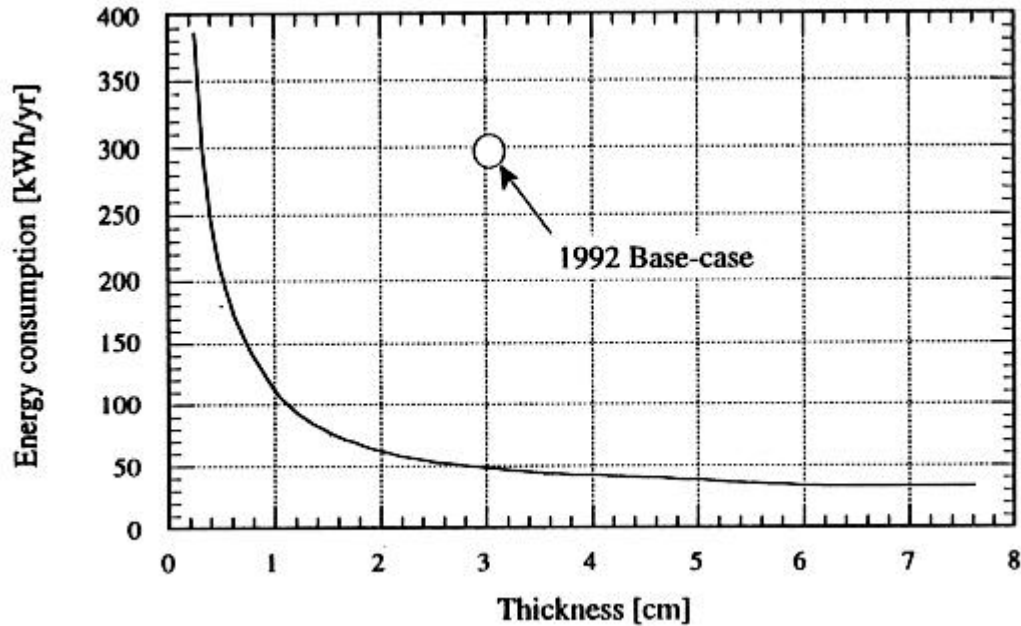

Figure 3 Energy consumption for refrigerator without frozen food compartment for varying thicknesses of vacuum insulated panels (door and cabinet)

Referring to Table 1, improving the K 215 by the use of VIPs would yield heat losses on the order of the door opening and food insertion losses. Assuming a gasket loss of 2.9 W based on 3.6 m gasket length and a thermal conductivity per unit length of 0.04 (W / m K)/m, the insulation-only loss of the K 215 is estimated to be 26.2 W. Replacing the cabinet with VIPs reduces this to 2.7 W which together with the gasket losses gives a total loss of 5.6 W. This is one third of the LER 200 heat loss and implies an appliance constant of only 0.28 W / K. In practice, this number is expected to be higher since there is a significant effect from the edge losses. However, an appliance constant of 0.5 W / K is considered possible for units in the 200 litre range. Moreover, the useful volume is increased by some 50 to 60 litre owing to the thinner walls possible with VIPs. With appliance constants of this level and COP's in the neighborhood of 3.0, the energy consumption will drop to around 29 kWh/yr or something like 3 W average. Of course food insertion and door openings will cause the instantaneous load to change substantially. However, if an energy store or buffer could be provided, then the average energy requirements would be low enough for the use of photovoltaic panels. Since the free-piston Stirling cooling system is capable of continuous capacity modulation, it is able adjust to food inserts and changing ambients with minimal temperature variations.

Another alternative to VIPs is the use of fully integrated vacuum insulation technology, sometimes referred to as vacuum super insulation (VSI). This technique involves an inner and outer stainless steel liner connected together around the door opening by a stainless steel membrane. The internal space is then filled with diatomaceous earth under a hard vacuum. This approach minimises the edge losses associated with individual panels and requires no foam insulation at all. 250 litre cabinets have been designed by the Swiss Foundation, Okokuehlschrank [4] and will be integrated with the Stirling cooler as part of this study.

THE SYSTEM

To be practical, the solar powered refrigerator is required to store cooling potential so that it may

operate for extended periods during no-sun conditions. One possibility is a storage battery. This option is heavy, inefficient and of limited life (around 1500 charge - discharge cycles for a deep cycle battery). An alternative is to store the cooling potential by freezing water inside the refrigerator. At least 24 hours storage could be provided by some 3 litres of water for the 200 litre VIP fridge. Such a system has been tested in a well insulated foam fridge and found to be completely satisfactory in maintaining internal temperatures [1]. The cold store places an additional load on the system while being charged. If the cold store is completely unfrozen, then something like 6 W average over the day would be needed minimally for the example VIP fridge described here. Knowing this gives enough information to size an appropriate panel which, of course, depends on local insolation conditions. For northern European climates, a 60 W panel should suffice.

CURRENT STATUS

In 1994, a 200 litre super insulated foam fridge was retrofitted with a photovoltaic Stirling cooling system for technology demonstration purposes. Since then the COP of the free-piston Stirling has been improved by some 50% and the peak cooling capacity has been raised from 50 W to almost 90 W. New techniques for cooler integration have been tested. One idea that shows promise is to use secondary heat transfer loops between the cooler and the cabinet heat exchangers. Since flow rates are so small, the power consumed by moving the fluid through such a loop is trivial (less than 0.5 W in this case). The method tested employed inertia pumps activated by the vibration of the cooler itself. Since the heat exchangers are not under pressure and heat fluxes are extremely low, they have been constructed out of plastic. Figure 4 shows preliminary data taken from an installation in a 365 litre Bosch foam fridge (appliance constant of about 1.4 W / K). Steady state power consumption at Standard conditions appears to be around 14 W which is some 10% better than the original equipment. Higher power consumptions than expected have been noted on the pumps and the electronic driver. It is expected that the overall steady-state power consumption will drop to something closer to 12 W when the system is properly optimised. These performance figures are very encouraging given the insulative properties of the test cabinet. For a properly configured 200 litre VIP or VSI cabinet, the overall energy consumption figures should come close to the expected values.

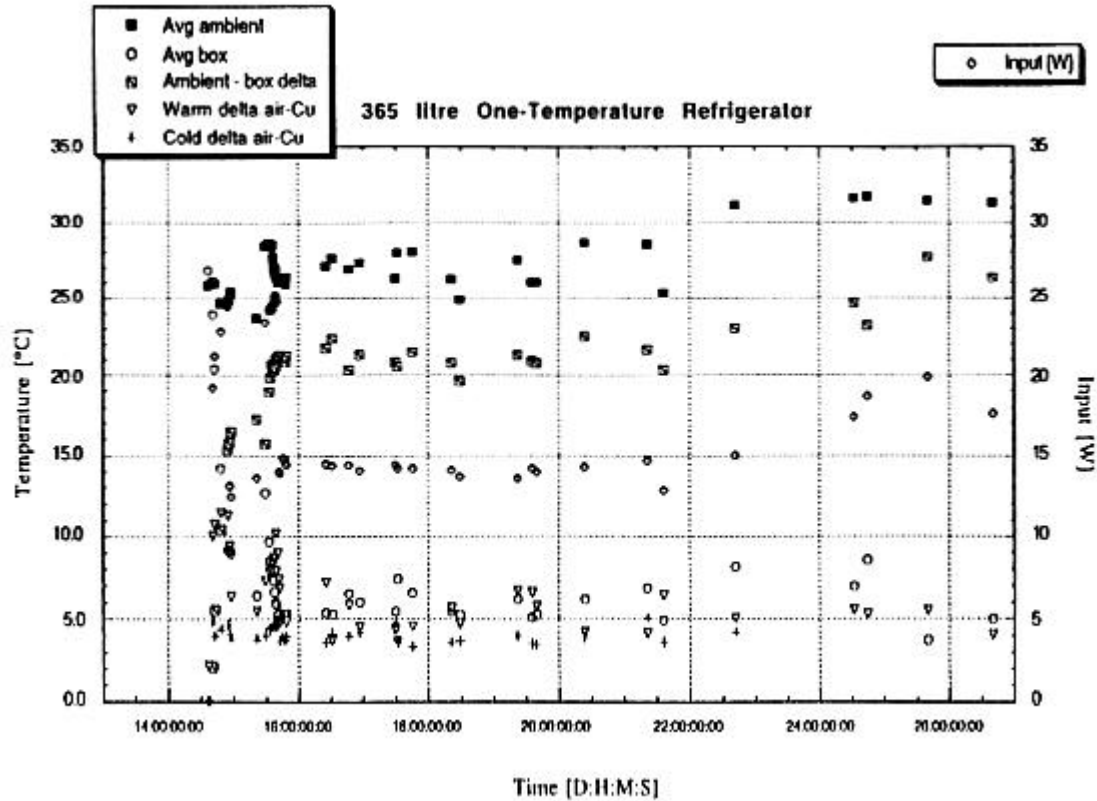

Figure 4 Preliminary measurements in 365 litre Bosch fridge

An additional application being pursued is the solar cool box shown in Figure 5. This is a small unit (30 litre) and is powered by either battery, mains or a small removable solar panel of about 20 peak Watts. One of two temperatures (freezer or fresh food) is selected by the user. A thermal store is integrated with the cool box to provide no-sun operation. Steady state power consumption will be less than 4 W which makes this an ideal portable unit. For example, connected to an automobile battery this unit will draw only about 0.3 A. A typical thermoelectric cool box of roughly the same volume consumes close to 40 W (about 3 A current) and only cools some 10°C below ambient.

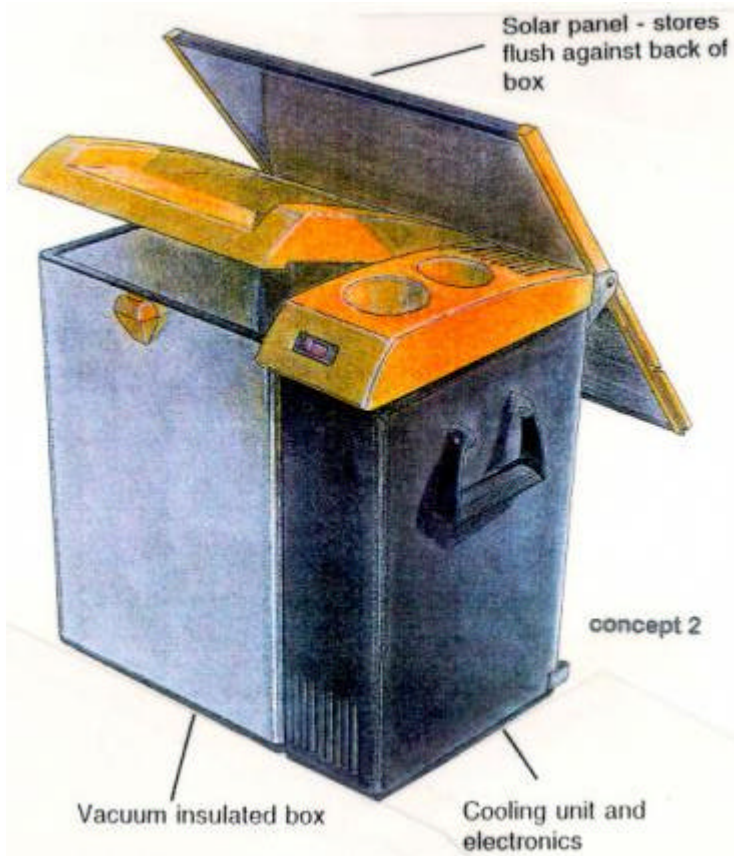

Figure 5 Configuration of solar cool box

COSTING AND RELIABILITY

Costing estimates based on a General Electric report for larger Stirling coolers [8] suggests that the small Stirling unit should be well under \$20 in large scale production. To some extent, this is born out by the steep cost - volume curve already generated. The manufacturing cost drops by a factor of 20 when going from 10 units to 1000 units. Reliability still needs to be quantified. A few hundred units will need to be put on test under statistically significant conditions. So far reliability information is somewhat anecdotal. For example, of the some hundred similar units built, there has not been a single failure related to wear. The longest continuous running time recorded is close to 12 000 hours.

SUMMARY

Free-piston Stirling coolers together with super insulated cabinets and cold stores offer an ideal combination for practical photovoltaic powered refrigerators. Though reliability data has not yet been generated, there is mounting evidence that these units will not detract from the domestic refrigerator as the most reliable consumer device ever manufactured.

REFERENCES

1 B.D. Mennink and D.M. Berchowitz. "Development of an Improved Stirling Cooler for Vacuum Super Insulated Fridges with Thermal Store and Photovoltaic Power Source for Industrialized and Developing Countries", IIR Conference - New Applications of Natural Working Fluids in

Refrigeration and Air Conditioning, Hannover, Germany, May 1994.

2 D.M. Berchowicz and R. Unger. "Experimental Performance of a Free-Piston Stirling Cycle Cooler for Non-CFC Domestic Refrigeration Applications", XVIII International Congress of Refrigeration, Montreal, Canada, August 1991, pp 848-852.

3 G. Chen. Free-Piston Gas Cycle Refrigeration for Medical Units: Technical Feasibility Investigation through Demonstration and Testing of a Laboratory Prototype, SBIR Phase I, Sunpower Inc., March 1994.

4 D.M. Berchowicz, D. Kiikka and B.D. Mennink. "Recent Advances in Stirling Cycle Refrigeration", 19th IIR Conference, The Hague, The Netherlands, August 20-25, 1995.

5 D.K. Benson and Potter T.F. "The Effect of New Priorities and New Materials on Residential Refrigerator Design", National Renewable Energy Laboratory, American Council for an Energy Efficient Economy, 2.13-2.21, 1992.

6 Gulbrandsen et al. Development of Energy Efficient Electrical Household Appliances, Part One: Refrigerators, Technical University of Denmark, Final Report for DG-XVII of The Commission of European Communities, 1993.

7 P.A. Waide. Mandatory Energy Efficiency Standards for Domestic Refrigeration Units in the European Community, Report, Energy Policy Research Unit, Greenpeace, 1994.

8 W.F. Bessler. Electrical Motor-Driven Non-Phase Change Gas-Cycle Refrigeration; Phase I: GCR System Study and Design, Final Report, Contract 85X-SJ837C, U.S. Dept of Energy or General Electric Corp., June 1993.

Note 1: COP (Coefficient Of Performance) = Heat Lifted / Input Power



[Back](#) to Publications listing.

**DEVELOPMENT OF AN IMPROVED STIRLING COOLER FOR VACUUM
SUPER INSULATED FRIDGES WITH THERMAL STORE AND
PHOTOVOLTAIC POWER SOURCE FOR INDUSTRIALIZED AND
DEVELOPING COUNTRIES**

by

B.D. Mennink and D.M. Berchowitz

The performance of a free-piston Stirling cooler and a super insulated fridge specifically designed for high efficiency domestic refrigeration is presented. Photovoltaic (PV) power is used without battery back-up. Overnight operation is ensured by the presence of a cold store. The cooling system modulates according to thermal load and available PV power and maintains high part-load efficiency. Preliminary results suggest that an energy consumption of below 50 kWh / yr is possible.

Free-piston, Stirling, Non-CFC, Domestic refrigeration, Photovoltaic, High-efficiency, Thermal store

DEVELOPMENT OF AN IMPROVED STIRLING COOLER FOR VACUUM SUPER INSULATED FRIDGES WITH THERMAL STORE AND PHOTOVOLTAIC POWER SOURCE FOR INDUSTRIALIZED AND DEVELOPING COUNTRIES

B.D. MENNINK
Innovatiebureau Mennink,
7201 AE Zutphen, The Netherlands
U. S. A.

D.M. BERCHOWITZ
Sunpower Inc.,
Athens, Ohio 45701,

1. INTRODUCTION

Environmental concerns have created a need for new domestic refrigeration equipment that do not use Chlorofluorocarbon (CFC) or Hydrochlorofluorocarbon (HCFC) compounds and operate at much higher efficiencies than current equipment. This paper is based on the results of a recent study done for the Province of North-Holland from The Netherlands. The aim is to demonstrate an environmentally friendly photovoltaic refrigerator of about 200 l with an energy consumption of around 50 kWh / yr. This energy consumption appears to better the world record for similar sized cooling-only refrigerators by some 50% (record set a few years ago by GRAM of Denmark with their LER 200 refrigerator). Currently, the average energy consumption of European refrigerators of this category is still about 300 kWh / yr. Given the enormous potential of efficient and environmentally sound refrigerators which could be developed on existing and cost-effective technologies, the Province of North-Holland wishes to demonstrate and thereby encourage:

- a) the introduction of stringent mandatory energy efficiency standards for domestic refrigeration in the European Community (EC).
- b) technical developments by refrigeration manufacturers and associated industry.
- c) the development of efficient and environmentally sound photovoltaic (PV) refrigerators for developing countries.

Apart from the Province of North-Holland, support for this work has been provided by a unique combination of several governmental and non-governmental organizations in the field of energy and the environment and the utility sector of The Netherlands.

Specifically addressed in this paper is the potential of a Stirling cycle cooled super insulated fridge. The performance characteristics are particularly suitable for direct photovoltaic operation without the need for storage batteries. No-sun operation is achieved by the use of a 24 hour thermal store consisting of water ice. The Stirling cooler is a free-piston, linear motor driven device described previously [1,2]. It is capable of continuous modulation and of maintaining high efficiencies down to very low lifts. The test results for the demonstration fridge suggest that this system could be of superior performance and quality of operation (noise and vibration) to current high efficiency refrigerators.

2. ENERGY CONSUMPTION, VACUUM INSULATED PANELS AND COP

More efficient domestic appliances would substantially contribute to world-wide efforts to reduce energy consumption. Across the European Community, for instance, the energy consumption for domestic refrigerators, freezers and fridge-freezers account for 24% of all domestic electricity use or 6% of the total electricity demand. According to Benson and Potter [3], the energy required by a refrigeration unit may be attributed some 75 to 90% to the thermal performance of the insulated shell. Door openings and insertion of food are of minor importance. This even holds for very well insulated refrigerators as has been shown by Guldbrandsen *et al*

[4]. Table I shows the distribution of thermal loads for two foam insulated GRAM models, the K 215 and LER 200. The thermal loads are for standard (25°C) and normal (21°C) conditions. Normal conditions include door openings, Q_d (24 / day) and insertion of food Q_f (4 kg / day). Q_{tr} is the insulation loss. This table confirms Benson and Potter's work and shows the potential for energy savings by further improvements to the insulation. Unfortunately, further increasing the thickness of European refrigerators is considered to result in impractically thick walls.

Table I Reduction of thermal load by better insulation

Insulation:	K 215			LER 200		
	Cabinet: 3 cm, Door: 2 cm			Cabinet: 6.5 cm, Door: 7 cm		
	Normal		Standard	Normal		Standard
Q_{tr}	23.3 W	(81%)	29.1 W	13.2 W	(71%)	16.5 W
Q_d	2.2 W	(8%)	—	2.2 W	(12%)	—
Q_f	3.1 W	(11%)	—	3.1 W	(17%)	—
Total	28.6 W		29.1 W	18.5 W		16.5 W
COP	0.94		0.83	1.56		1.41
Appliance const.	1.46 W / K			0.83 W / K		

The Group for Efficient Appliances (GEA) showed that by using available technologies, the Least Life Cycle Cost (LLCC) coincided with energy efficiency improvements of between 38 and 55% [5]. Only conventional foam blown insulation of limited thickness was assumed. The suggested methods were increased cabinet insulation thickness, more efficient compressors, improving door seals and better evaporators and condensers. The largest gain being from increased insulation thickness. Pay back periods of between 3 to 4 years were obtained. A financial penalty was incurred for reduced storage volume which resulted in a minimum cost at about double insulation thickness. For example, for the category R6 European refrigerator without a freezer, the LLCC point for a base-case (Storage volume 179 l, standard condition, unmodified energy consumption 301 kWh/yr) was 144 kWh /yr. The original LER 200 with somewhat thicker insulation has an even lower energy consumption at 103 kWh/yr, later improved further to 80 kWh/yr.

To further improve insulation without sacrificing internal volume it is necessary to consider vacuum insulation panels (VIP). Two developments expected to enter the marketplace in 1995 are silica powder filled plastic panels from Degussa (Germany) and fiberglass filled stainless steel panels from Owens Corning (USA). The thermal conductivity of the Degussa panel is 6 to 8 mW / m K. Owens Corning panels are 1.5 mW / m K at the center of the panel and an average of 2.4 mW / m K for 75 X 75 cm panels [6]. For comparison, polyurethane foam is around 24 mW / m K. Recently, Greenpeace investigated the effect of progressively thicker VIPs using the GEA model and a thermal conductivity of 2.9 mW / m K. Figure 1 shows the results of this study from which the enormous potential of VIPs is evident. For the same thickness of insulation for the base-case GEA model (3 cm), the energy consumption drops from 300 kWh / yr to 50 kWh / yr without any other design improvements.

Referring to Table I, improving the K 215 by the use of VIPs would yield heat losses of the order of the door opening and food insertion losses. Assuming a gasket loss of 2.9 W based on 3.6 m gasket length and a thermal conductivity per unit length of 0.04 (W / m K)/m, the insulation-only loss of the K 215 is estimated to be 26.2 W. Replacing the cabinet with VIPs reduces this to 2.7 W which together with the gasket losses gives a total loss of 5.6 W. This is one third of the LER 200 heat loss and implies an appliance constant of only 0.28 W / K. In practice, this number is expected to be higher since there is a significant effect from the edge losses. However, an appliance constant of 0.5 W /K is considered possible for units in the 200 l range. Moreover, the

useful volume is increased by some 50 to 60 l owing to the thinner walls possible with VIPs. With appliance constants of this level, the COP of the cooling unit needs to be better than 1.75 in order to obtain energy consumption of less than 50 kWh / yr. Vapor compression units typically used in small refrigerators would be over-sized owing to the difficulty of maintaining reasonable efficiency at low capacities. Temperature control would therefore be achieved by on-off modulation which introduces a substantial efficiency penalty due to the redistribution of the refrigerant (cycling losses). Additionally, since the capacities are so much larger than the steady heat loss from the fridge (100 W versus 5.6 W heat loss), the cycle seldom fully establishes itself before it is switched off. Thus steady-state operation is never achieved, and this introduces further losses. The LER 200, for example, had a run time of only 20% with the smallest available compressor (Danfoss TL2A). Ideally, what is needed is a cooling system capable of continuous capacity modulation while maintaining high efficiency down to low lifts. Such a system would adjust to food inserts and changing ambients with minimal temperature variations. It is shown here that the free-piston Stirling cooler has almost ideal characteristics for this application.

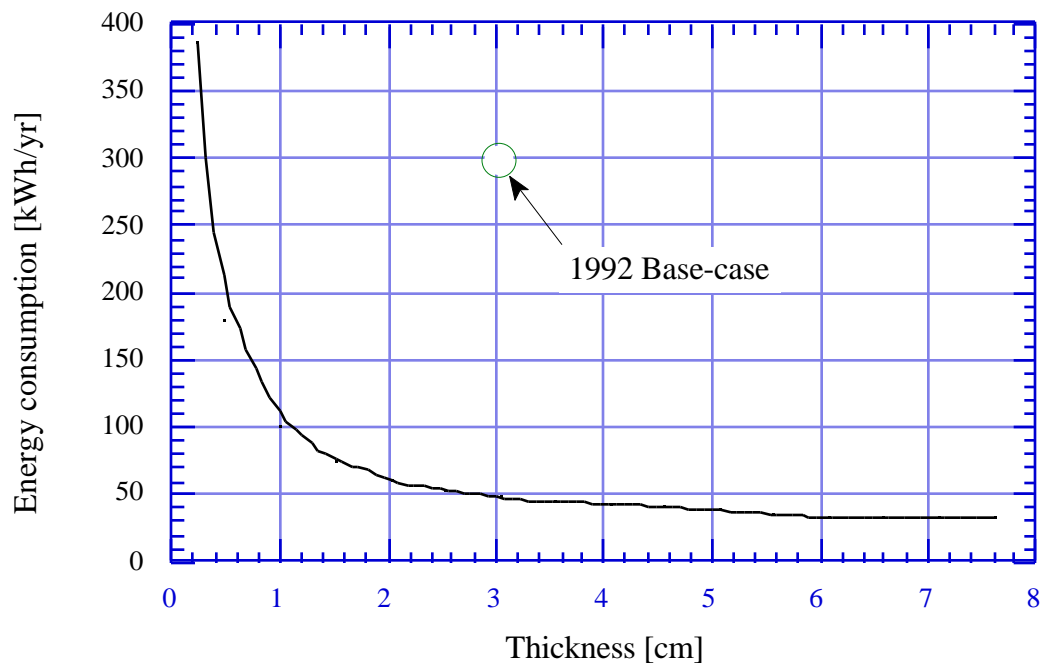

Figure 1 Energy consumption for refrigerator without frozen food compartment (R6) for varying thicknesses of vacuum insulated panels (door and cabinet)

3. BASIC SYSTEM

The domestic refrigerator used for this study consists of a super insulated cabinet, a free-piston Stirling cooler, thermal store / heat acceptor combination, heat rejector and driver electronics. Details and characteristics of each of these components are as follows:

1) Cabinet

The cylindrical test cabinet is polystyrene foam insulated and was supplied by FORON GmbH. Internal volume is about 200 l and is to be kept at an average temperature of 5°C. Production fridges are expected to be vacuum insulated but an example unit was not available for initial testing. The appliance constant is about 1.1 W/K for the test unit, a production unit is expected to

be closer to 0.50 W/K.

2) Stirling cooling unit (Minicooler)

The Stirling cycle employs helium as its working medium. No phase changes occur during the cycle and therefore all heat transfer takes place over a finite temperature differential. The particular unit used here is a free-piston machine driven by a linear motor (Figure 2). All internal running surfaces are supported by gas bearings so that during steady operation no contact wear takes place. The entire unit is hermetically sealed and dynamically balanced for low noise and vibration. Operational characteristics are such that the lift (or capacity) are easily modulated since the piston amplitude is directly proportional to the drive voltage. More complete technical and theoretical descriptions are contained in [1,2,8].

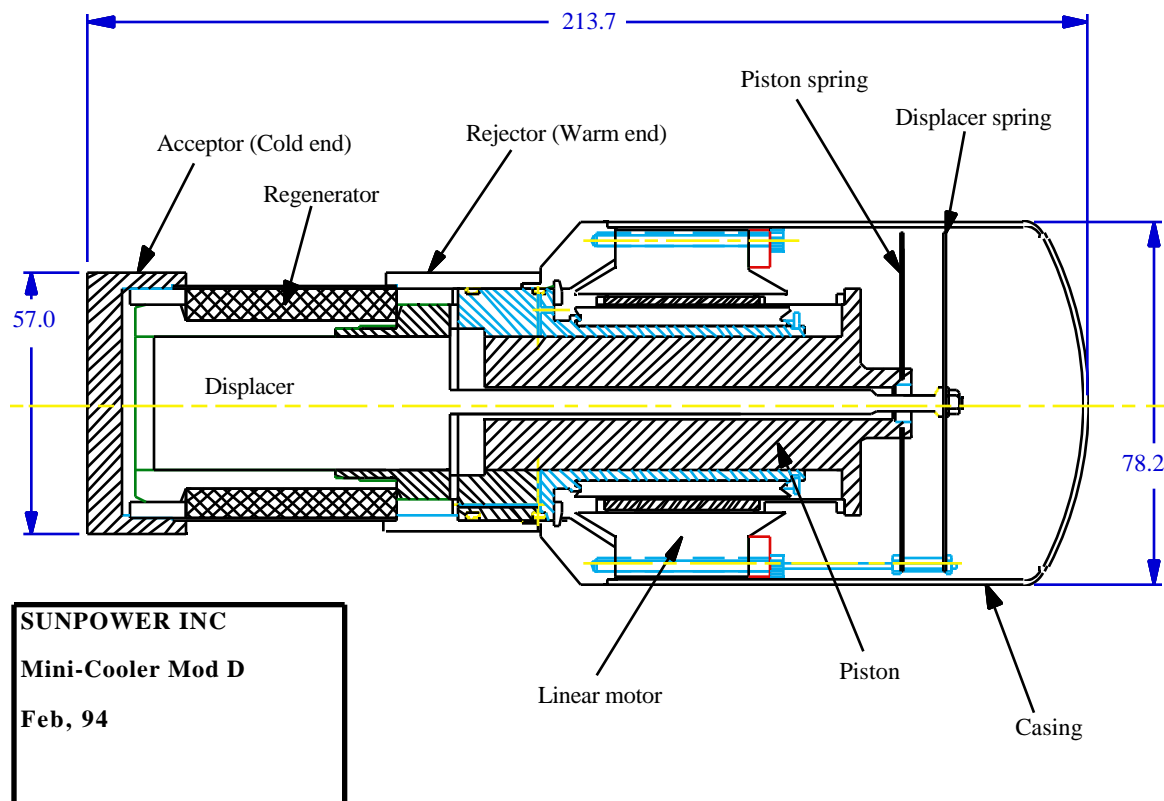

Figure 2 – General arrangement of Minicooler

3) Thermal store / heat acceptor

In order to avoid battery storage and its attendant reliability problems, excess cooling potential is stored by freezing about 5 l of water within the heat acceptor. This is sufficient for about 24 hrs of no-sun operation or roughly equivalent to a 40 Ahr battery using a 50% discharge cycle. Batteries are not maintenance free and often cause reliability problems. The World Health Organization has recently encouraged manufacturers of PV vaccine refrigerators to develop battery free systems. The test unit employs conduction as the means to convey heat transfer to the Stirling. In a production unit a heat pipe would be used.

4) Heat rejector

In the test unit, heat rejection is by forced convection from fins placed in direct contact with the warm section. Free convection is the method of choice for production machines.

5) Driver electronics

For photovoltaic or DC operation, it is necessary to convert the DC supply to an AC source at the cooler operational frequency (50 Hz in this case). This is done by using a simple square wave driver which is pulse width modulated in order to control the RMS voltage in response to a temperature signal. Since maximum power is provided by the panel at roughly 16 VDC across the panel, the modulation control needs to adjust the cooler power so that the panel voltage remains in the neighborhood of 16 VDC. Panel voltage control is overridden by the temperature control. Finally, to ensure that the cooler may never be over-powered by the panel, it is also necessary to provide a voltage cut-off so that irrespective of available power, the cooler is automatically limited to the maximum power that it is able to draw without over stroking. Battery connection locks the input voltage and therefore the available capacity. Provided that this capacity is greater than that required by the fridge, the temperature modulation control will ensure proper operation. AC or mains power is relatively straight forward. A connection is simply made by way of a transformer directly to the grid. In the test unit, an on/off modulation is used for mains power. However, in principle, modulation is possible by a number of means, for example, a simple triac control.

Figure 3 gives an idea of the overall installation and size.

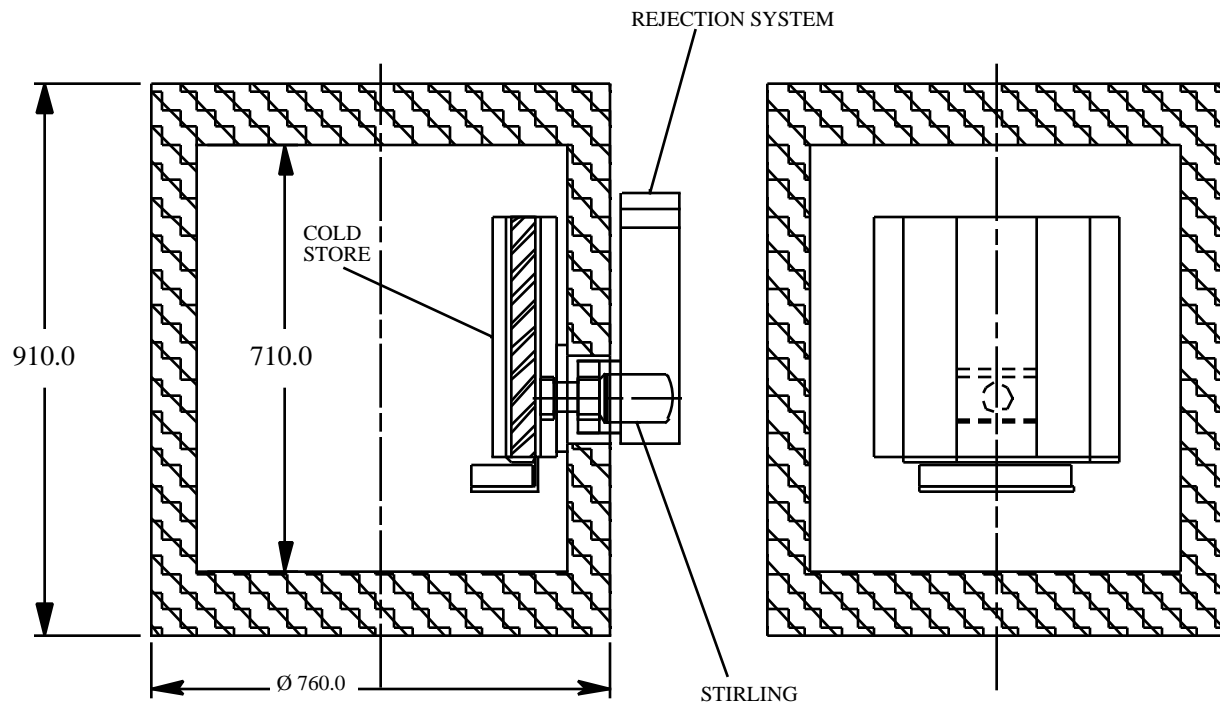

Figure 3 Overall configuration of demonstration fridge

4. PROCEDURE AND RESULTS

Some work has already been done in the use and potential advantages of free-piston Stirlings in small domestic refrigerators [9,10]. Unfortunately, none of the available small Stirlings are truly optimized for domestic refrigeration temperatures. It was therefore necessary to modify a small Stirling and reoptimize its performance for the required temperatures and capacities (Table II). One of Sunpower's Minicoolers was selected for this purpose. Bench tests produced the performance curves shown in Figure 4 from which the modulation and efficiency characteristics are clear. The difference between total and cooler inputs is due to electronic losses. Figure 5 shows one of the essential characteristics of the Minicooler, namely its ability to maintain efficiency to very low lifts. In this case, the COP is close to its maximum at lifts above about 8 W. Conduction losses for the Minicooler is 0.06 W/K.

Table II Performance specifications (Mod D)

Optimum point lift [W]	30.0 @ 0°C to 30°C
Maximum lift [W]	50.0 @ 0°C to 50°C
Minimum lift [W]	10.0
Operational frequency [Hz]	50.0
COP	>2.0 @ 0°C to 30°C at optimum point
COP (maximum lift)	>1.5

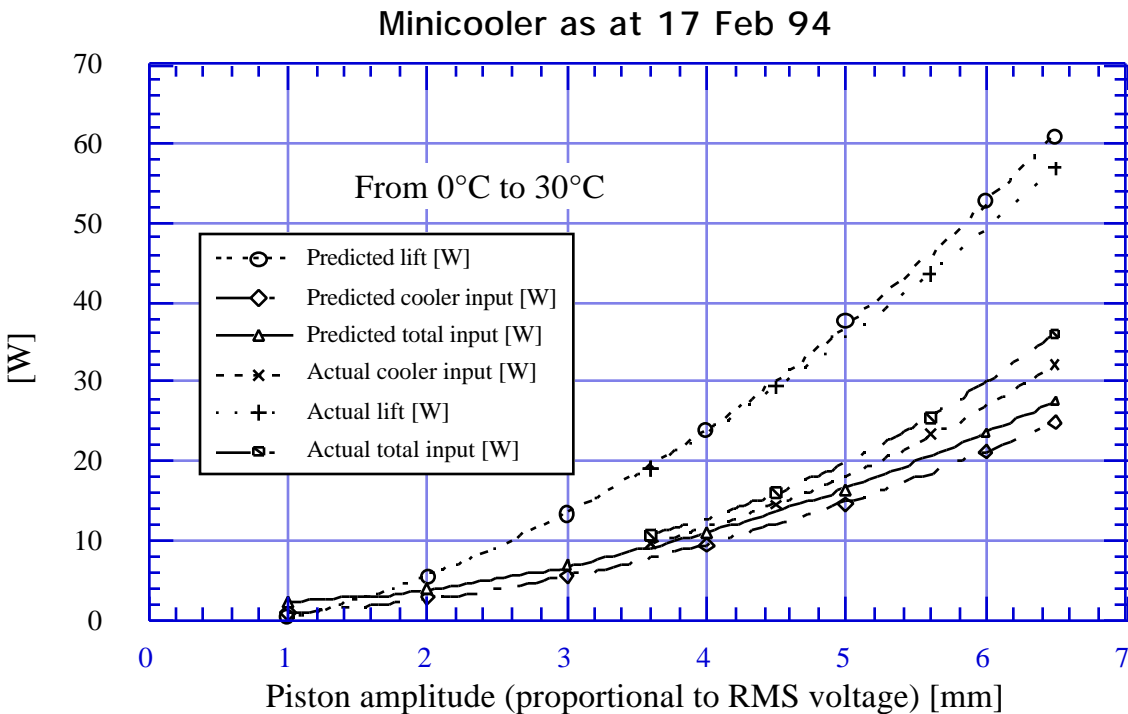

Figure 4 Bench test results for Minicooler

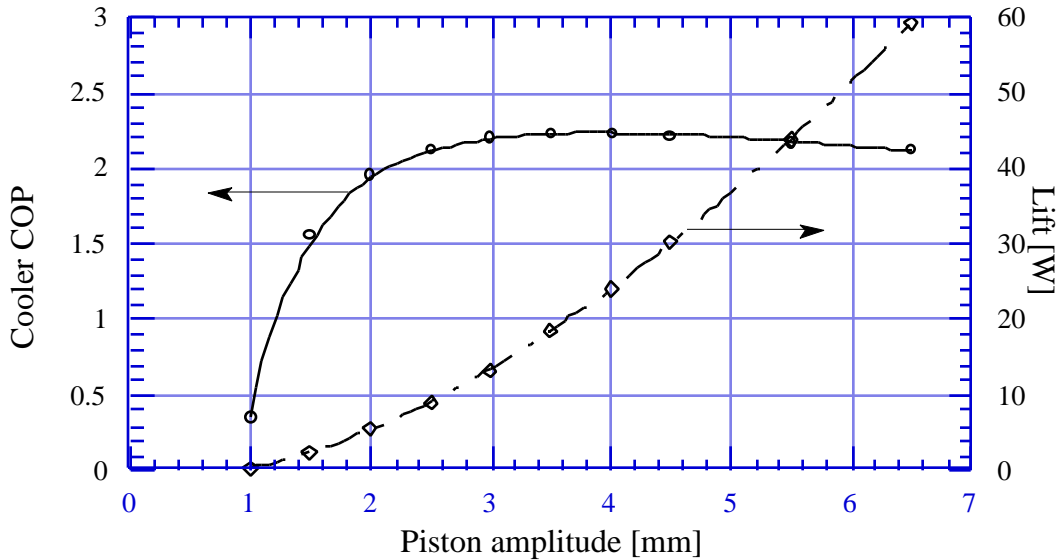

Figure 5 Coefficient of performance (COP) and lift as a function of piston amplitude for 0 to 30°C (COP = Lift / Input to cooler)

Ideally, the heat transport should be organized by way of heat pipes (or reflux boilers). This combination works very well with Stirlings since the heat pipe tends to impress an isothermal condition on the Stirling [11] and cuts down the off-state conduction loss. Without heat pipes, heat transfer occurs by sensible mechanism as opposed to a phase change mechanism. Sensible heat transfer introduces temperature differentials which result in a loss of performance [8]. For the purposes of the demonstration fridge, heat pipes were not used owing to pressures of time and money.

The demonstration fridge consists of 70 mm of polystyrene foam insulation. The appliance constant measured at about 1.1 W/K is therefore higher than what would be expected for a vacuum insulated fridge. This, of course, not only increases the required capacity, but also results in greater average temperature differentials (lower cold side and higher warm side temperatures) which have a deleterious effect on the overall COP.

High efficiency refrigerators are very attractive for photovoltaic operation owing to their low average power consumption. However, batteries are generally required for both storage and in order to accommodate the high starting currents of conventional vapor compression systems. Since the free-piston Stirling draws extremely low starting currents, a battery is not necessary. It is therefore possible to consider alternative energy storage methods. The freezing of water is ideal for this purpose from efficiency, environmental and cost view points. For the demonstration system, a cold-store was close coupled to the Stirling so that conduction temperature differentials would be minimized. The cold-store itself tends to isothermally the cold side heat transfer and is therefore an aid to maintaining high efficiency. Care had to be taken to ensure that the freezing of the water occurs in such a way so as to avoid stressing the container. Sufficient heat transfer surface had to be provided so that the cold-store is able to hold the internal temperatures within the required limits.

The heat rejector for the demonstration unit consists of directly cooling the warm side surface

by the use of extended surfaces and a fan. At steady state conditions, the heat rejector runs some 0.18 to 0.20 K/W of heat rejected above ambient. The fan consumes 1.3 W. In production, a heat pipe would be integrated into the cabinet outside wall. An enhancement in overall performance would be expected from such a system.

For direct photovoltaic use, some additional losses are encountered in the conversion of DC power to the necessary AC power. These losses occur in the control electronics and in the cooler itself owing to higher harmonic currents generated by the square wave driver. From Figure 5 it can be seen that measured electronic losses are around 2 W at the design lift of 30 W. Efforts are underway to reduce this to less than 1 W.

Preliminary data is shown in Table III when operated on a constant DC power source and cold store respectively. Average fridge temperatures are too low at this time, but despite this, the performance is quite good, even for the relatively low ambient conditions and poor appliance constant. Extrapolating these results to a 25°C ambient leads to a cooler input of 11 to 12 W.

Table III Preliminary test data for system

Date	Input* [W]	Current [A]	Cold side [°C]	Control temp [°C]	Fridge top [°C]	Fridge bottom [°C]	Reject [°C]	Amb [°C]	Steady ?
3/4	24.3	2.6	-5.1	1.3	—	—	26.8	17.4	no
3/5	7.6	1.2	-4.8	-1.1	4.6	0.3	17.9	16.4	yes
3/5	10.8	1.5	-5.0	-1.8	5.5	—	21.2	18.7	no
3/6	7.7	1.2	-4.1	-1.5	4.3	0.2	18.0	16.5	yes
3/6	8.5	1.3	-4.2	-1.4	5.1	0.4	19.6	18.0	no
3/7	7.8	1.25	-4.8	-1.5	4.6	0.3	18.7	16.8	yes

The following on cold store only

Date	Input* [W]	Current [A]	Cold side [°C]	Control temp [°C]	Fridge top [°C]	Fridge bottom [°C]	Reject [°C]	Amb [°C]	Steady ?
3/7	0.0	0.0	0.4	0.4	6.4	2.3	19.4	20.5	?
3/7	0.0	0.0	0.5	1.1	6.9	3.0	14.3	20.2	yes ?
3/8	0.0	0.0	0.0	1.2	6.5	3.1	11.5	18.7	yes

*Input does not include fan and electronics (less than 2 W at steady-state input)

Though steady-state data has not yet been taken for direct AC operation, the difference in input between direct AC operation and square-wave DC operation for two operating points has been determined. From this data (not presented here) it appears that up to 1 W is wasted due to the higher harmonics which are present in the square wave.

The fridge has also been run on photovoltaic power. Steady conditions are difficult to achieve on the sun and meaningful average performance takes a long time to gather. At this point, the electronic controls have proven to be effective at maximizing available power. Positive cooling has been accomplished at levels as low as 3 W to the cooler. Average input for PV operation has not been determined.

Noise is an important criterion which has only been qualitatively determined. On mains power the fridge is almost inaudible from the front. On the square wave driver, noise levels are definitely higher but not intolerable.

5. DISCUSSION

Obvious improvements will arise from adjusting the system to run a little warmer and improving the appliance constant to the expected 0.5 W/K. Heat lifts and the consequent temperature differentials will be much lower. The heat pipe option will also tend to bring the cold side temperature closer to the cold store temperature and reduce off-state conduction losses. All of these factors will have a strong effect on the overall performance of the system. The following list indicates the potential for the final system:

<u>Activity</u>	<u>Improvement</u>
Increasing internal temperatures to 5°C average	10% in COP
Appliance constant improved to 0.5 W/K	Input cut by at least 50%
Heat pipes	> 10% in COP
Sine wave driver (removes higher harmonics)	< 10% in COP

With these improvements, the average system COP becomes about 2 at standard conditions. Hence, with a thermal load of 10 W, the average input is about 5 W with yearly energy consumption of below 50 kWh. Note that no improvements have been suggested for the Stirling cooler itself. Even here some reoptimization is possible with an improvement of some 5 to perhaps 15% in COP.

6. CONCLUSIONS

It has been shown that the free-piston Stirling cooler with its high performance at low thermal loads is well suited to the cooling requirements of super or vacuum insulated refrigerators. This characteristic, together with a cold-store, enables practical and reliable photovoltaic operation without batteries or mains back up. Overall efficiencies are expected to establish records that will be unchallenged for a long time.

REFERENCES

1. Berchowicz D.M. and Unger R. "Experimental Performance of a Free-Piston Stirling Cycle Cooler for Non-CFC Domestic Refrigeration Applications", XVIII International Congress of Refrigeration Inc., Montréal, Canada, August 1991, pp 848-852.
2. Berchowicz D.M. "Free-Piston Stirling Coolers", International Refrigeration Conference - Energy Efficiency and New Refrigerants, Purdue University, July 1992
3. Benson D.K. and Potter T.F. "The Effect of New Priorities and New Materials on Residential Refrigerator Design", National Renewable Energy Laboratory, American Council for an Energy Efficient Economy (ACEEE), 2.13-2.21, 1992.
4. Gulbrandsen *et al.* *Development of Energy Efficient Electrical Household Appliances, Part One: Refrigerators*, Technical University of Denmark, Final Report for DG-XVII of The Commission of the European Communities, 1986.
5. Group for Efficient Appliances (GEA). *Study on Energy Efficiency Standards for Domestic Refrigeration Appliances*. Final Report for DG-XVII of The Commission of the European Communities, 1993.
6. Personal communication with B.J. Arch of Owens Corning, February 1994.
7. Waide P.A. *Mandatory Energy Efficiency Standards for Domestic Refrigeration Units in the European Community*, Report, Energy Policy Research Unit, Greenpeace Int, To be

published.

8. Berchowitz D.M. "Free-Piston Stirling Coolers for Intermediate Lift Temperatures", 27th IECEC, *SAE paper 929039*, San Diego, California, August 1992.
9. Bessler W.F. *Electrical Motor-Driven Non-Phase Change Gas-Cycle Refrigeration; Phase 1: GCR System Study and Design*, Final report, Contract 85X-SJ837C, U.S. Dept of Energy or General Electric Corp., June 1993.
10. Chen G. *Free-Piston Gas Cycle Refrigeration for Medical Units: Technical Feasibility Investigation through Demonstration and Testing of a Laboratory Prototype*, SBIR Phase I, Sunpower Inc., March 1994.
11. McDonald K., Rosenfeld J. and Berchowitz D.M. "Stirling Refrigerator for Space Shuttle Experiments", in preparation, Monterey, CA, IECEC, Aug 1994.

DEVELOPPEMENT D'UN REFRIGERATEUR STIRLING A PISTON LIBRE A HAUTE PERFORMANCE ENERGETIQUE POUR LES APPLICATIONS DE REFRIGERATION DOMESTIQUES

RESUME: Sont présentées les performances d'un réfrigérateur Stirling à piston libre en combinaison avec un caisson de réfrigération à très haute isolation avec accumulateur thermique et actionné par une source d'énergie photovoltaïque pour les pays industrialisés et les pays en voie de développement. Le réfrigérateur fonctionne pendant la nuit sans accumulateur électrique grâce à l'accumulateur thermique. D'autres caractéristiques comprennent une modulation en capacité continue avec un coefficient de performance élevé, la possibilité de brancher le système sur le réseau électrique publique et un niveau de bruit bas.

LOW COST SMALL CRYOCOOLERS FOR COMMERCIAL APPLICATIONS

A. Karandikar and D. Berchowitz

Sunpower, Inc.
6 Byard Street, Athens, Ohio 45701

Presented at the 1995 Cryogenic Engineering Conference, Columbus, Ohio, July 17-21, 1995.
Published in *Advances in Cryogenic Engineering*, Volume 44.
Plenum Press. Reproduced by permission.

ABSTRACT

Two models of small free piston cryocoolers with the potential for low cost and high reliability have been developed for emerging commercial applications. Model M223 has been designed for applications ranging from 173 K to 273 K lifting up to 40 W at 223 K. The other, model M77, has been designed for operation from 65 K to 150 K. This unit will lift up to 4 W at 77 K and more than 10 W at 150 K. Both passive and active balance units have been implemented to reduce vibration. Performance data for each model are presented over a wide temperature range for representative machines. A summary of the life and reliability information to date is also included.

INTRODUCTION

The machines described here, the models M223 and M77, are based on a common hardware platform. The entire drive section of the machines is essentially identical. The main differences between the machines are in the design of the cold finger and thermodynamic section. The common hardware approach offers two main advantages, namely, increased sample size for life and reliability assessment and larger production volumes for common components. Another useful result is that modified versions of these machines may be developed for a fraction of the development time and cost of a new machine. Some examples include a coupled version of an M223 which cooled a refrigerator (SOR/F) during Space Shuttle Discovery's 10 day mission in February 1994 [1], and another modified M223 installed in a small super insulated domestic refrigerator [2].

The M223 has been optimized to lift 35 W at 223 K with a reject temperature of 313 K and an input of 65 W (Figure 1). The principle application is to cool electronic multichip modules to low temperatures in order to improve clock speeds [3,4]. This application requires a cooler that is highly reliable (> 60,000 hours with no maintenance), low in cost for large volumes (< \$100 at 1 million per year), and compact.

The M77 machine has been optimized to lift 4 W at 77 K with a reject temperature of 313 K. Input power is about 90 W. This unit was developed for cooling high temperature superconductivity (HTS) devices (Figure 2). In order for many emerging HTS applications to become commercially viable, a cooler which is highly reliable (> 60,000 hours with no maintenance), compact, and relatively low in cost for medium volumes (< \$1500 at 5,000 - 10,000 per year) is required.

To date, 107 machines have been built using the common hardware platform and 10 more M77's are scheduled for completion by the end of August, 1995. While some machines are operating in test environments, a number of others are being used in the development of systems and field trial

evaluations.



Figure 1. M223 with controller.



Figure 2. M77 with balance motor.

FEATURES AND SYSTEM DESIGN

Both the M223 and M77 are free piston Stirling cycle machines with the cold finger and compressor assembly integrated into one compact package (integral configuration). The moving components, the piston and displacer, are levitated on gas bearings during operation, thereby virtually eliminating

friction and wear. The gas bearings make it possible to achieve long life and high reliability and consume less than 2 W. Additional advantages include modulation by adjusting RMS voltage and balancing of both moving components by the use of only one balancing device.

An electronic controller ramps the machine down from ambient to operating temperature and modulates the machine to maintain cold end temperature. Cold end temperature is adjustable.

A passive balance absorber consisting of a sprung mass is used to reduce casing vibration to within 25 μm amplitude. A balance motor which may be driven by dedicated electronics has been developed for ultra low casing vibration requirements. This results in some additional mass and increased length. The units shown in Figure 2 include this balance motor.

PERFORMANCE DATA

The performance of free piston Stirling coolers may be mapped as shown in Figures 3 and 4. These curves were generated using Sunpower's proprietary Stirling simulation program SAUCE and indicate input and lift as a function of piston amplitude and cold end temperature for a given reject temperature. Figure 4 curves were calibrated at 77 K and tend to underpredict at lower temperatures and overpredict at warmer temperatures.

The maximum input power is limited by either the mechanical limits or the magnetic saturation of the linear motor. When the machine is first turned on, the power consumption for a given piston amplitude is much lower than at low temperatures so the input power is limited by the mechanical stops. As the machine cools down, the input power for a given piston amplitude increases until limited by magnetic saturation of the linear motor.

Sensitivity to reject temperature is shown in Figure 5 for the M77. As may be expected, lift capability is reduced with increasing temperature. The scatter in data is both a function of the variation in performance and instrumentation error. No special care is taken to reduce loading caused by radiation on the cold finger which could be as high as 0.5 W at 77 K.

Figure 6 shows measured COP for the M223, M77, and other custom machines based on the same hardware platform. The rejector temperature in all cases is fixed at 313 K and COP is defined as lift divided by input power to the linear motor. The ideal COP is shown for comparison.

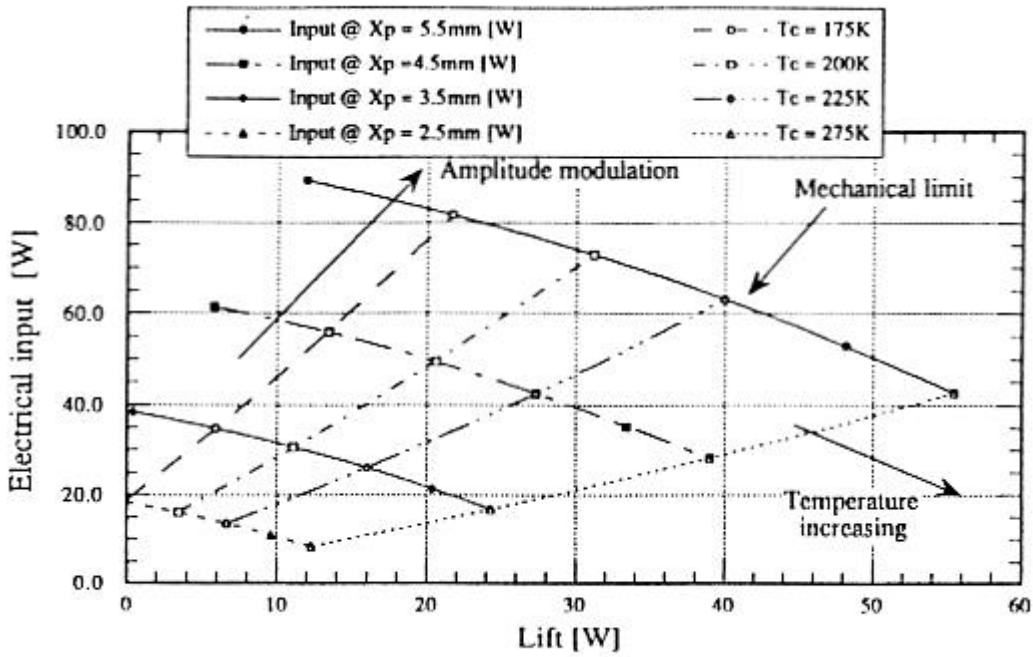

Figure 3. M223 Performance map (x_p = piston amplitude, T_c = cold end temperature, $T_{reject} = 313$ K)

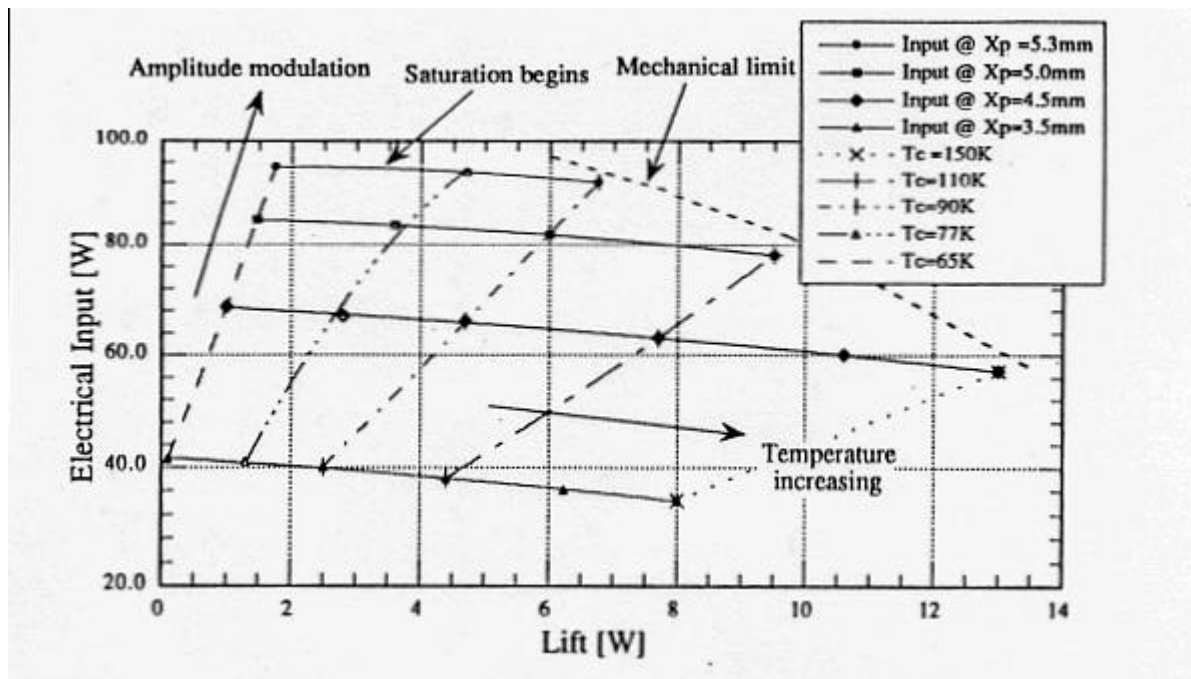

Figure 4. Performance map of M77 (x_p = piston amplitude, T_c = cold end temperature, $T_{reject} = 313$ K).

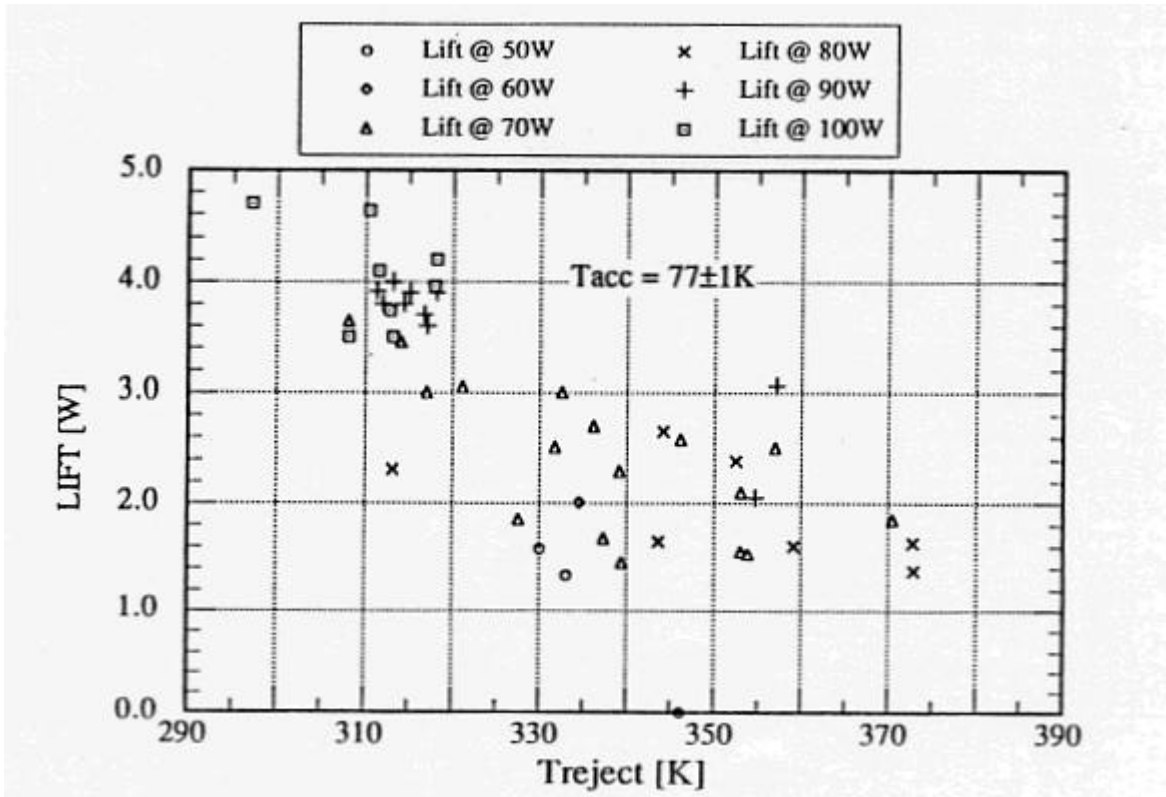

Figure 5. Lift vs reject temperature for M77 at 77 K.

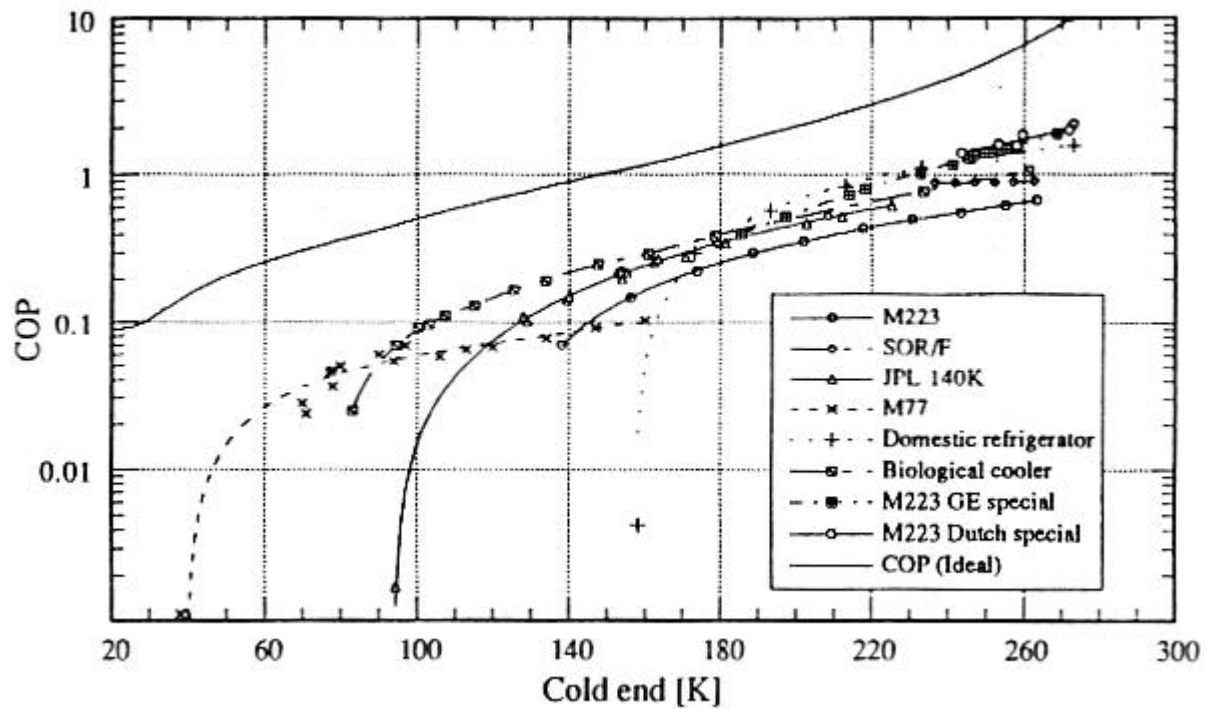

Figure 6. COP vs cold end temperature for different machines at reject temperature of 313 K.

OPERATIONAL CHARACTERISTICS

Tests have been conducted on two machines operating with reject temperatures up to 373 K but testing at low temperature ambients (<288 K) has not been done at Sunpower. No cooler damage is expected over an ambient temperature range of 233 to 373 K. The electronic components used are standard commercial grade and are rated for ambient temperatures from 273-348 K. If required, components are available for operation from 218-398 K.

Custom machines have been designed to tolerate sustained 5g loading (Space Orbiting Refrigerator/Freezer -SOR/F) and momentary 20g without catastrophic destruction. During the Shuttle mission, the SOR/F unit operated during both the ascent and descent stages of the mission. Space vehicle launch vibration testing has been conducted on only one unit (M223); there was no damage or degradation in performance.

EMI tests were conducted by GE Government Services (now Martin Marietta) for space shuttle operation on both the SOR/F custom units and on one M223. These tests showed one exceedence which was not considered to be serious [5]. The main source of EMI radiation was in the power leads to the cooler. This could be reduced by incorporation of line filters.

Voltage surges have not presented problems to date. The electronic drivers deduce the piston amplitude from the back-EMF. Therefore, the drivers may be subjected to voltage variations up to the maximum limit of the electronic components without affecting cooler performance.

LIFE AND RELIABILITY

To date, life and reliability testing has been sparse and incidental. In order to obtain useful life and reliability data, tests need to be conducted on a statistically significant sample size (minimum 100 machines) under appropriate stress conditions. Up to this point, most life data have been anecdotal and gathered through feedback from customers. Some formal reliability testing has been done on the M223.

Since the M223 was initially developed in 1991, a total of 107 machines have been built and delivered, including the M77 and modified versions for various applications and customers. To date, two M77 units have operated continuously for over 12,000 hours and at least two other M77's have operated at customer facilities for over 2000 hours. An M223 operated at Sunpower for 5500 hours at full load with no degradation in performance. A summary of deliveries, failures, and operational hours is shown in Table 1.

Table 1 Summary of deliveries, failures, and ho

Machine type	Client	Old or new motor?	Number built	Number in operation	# failures	
M223	Proprietary	old	32	Info. not available	4 known	Magn
M223	Various	old	5	Info. not available	-	
M223	Proprietary	new	28	Info. not available	-	
M223	Proprietary	new	8	8	0	
M223	Sunpower	new	1	0	*	*Te dam
Modified M223 SOR/F	NASA	new	3 opposed pairs	0	1 known	M
Modified M223	Mennink	new	2	2	1	Bo
M77	Proprietary	old	9	Info. not available	Info. not available	
M77	Proprietary	new	3	Info. not available	Info. not available	
M77B	LLNL	new	2	2	0	
M77B	NASA Goddard	new	8	8	2	Inadeq hydr
M77B	UCSB	new	1	1	Info. not available	
M77B	LLNL	new	2	2	Info. not available	

Wear is generally considered to be the primary failure mode. In order to investigate the efficacy of the gas bearings to reduce wear, a number of tests have been completed and are included in Table 2. These include rapid stop/start tests, temperature cycling, and machine operation with the gas bearings deactivated. The number of stress cycles induced far exceed those seen in normal operation. All 3 failures during these tests were due to magnet delamination and not bearing failure. This failure mode has been corrected with a redesign of the magnet assembly.

Table 2 Stress Tests

Machine type	Old or new motor	Stress test type	Number of units	Number of stress cycles Total operation time	Failures
--------------	------------------	------------------	-----------------	---	----------

M223	old	Rapid stop/start @1200/hr	4	2.5 million cycles each	1
M223	old	Operational cycling from 293K to 223K @ 12/hour	4	12000 cycles each	1
M223	old	Continuous duty	4	2700+ hours	1
M223	new	Deactivate bearings	1	140 hours	0
M223	new	318K ambient temperature	1	890+ hours ; then shipped to customer	0
M77	new	373K reject temperature	1	50+ hours	0

Vacuum bakeout procedures have been improved; however, it is unknown whether this procedure is good enough for 60,000 hours of trouble free operation. With the large diameter cold finger, the machines are less susceptible to problems caused by water and other contaminants. There have been two known instances where inadequate bakeout resulted in reduced performance, while in another case the machines have shown no problems in over 12,000 hours of operation.

A large amount of qualitative information has been gathered which has been useful in identifying potential problems. All of the known failures have been dealt with either through design changes or by improved quality control. The number of "infant mortality" issues has dropped to a negligible level. So far there has not been a single gas bearing failure.

MACHINE COST

The M223 and M77 machines were designed to be low cost machines at medium to high volumes. Increasing volume is the primary factor in reducing cost, and the common platform shared by the machines makes it possible to increase volume for a number of parts.

A cost study conducted by General Electric as part of a gas cycle refrigerator project concluded that a 205 W unit of similar proportions could be made for \$88 at volumes of 250,000 per year and as low as \$30 at volumes of one million per year [6]. Based on this study, using the same labor costs and prorating materials according to mass, an M223 should cost about \$20 for volumes of one million per year.

Another cost study for the M223, the details of which are confidential, indicated a manufacturing cost of \$363 for volumes of 10,000 per year. These two studies show evidence of meeting the cost targets for the applications under consideration.

CONCLUSION

There are emerging technologies which require low cost, highly reliable cooling machines. The M77 and M223 are two possible candidates for these applications. However, in order to fully realize commercial viability, the following tasks need to be completed:

- obtain statistically significant reliability data
- obtain statistically significant life data
- conduct a more rigorous production and manufacturing evaluation
- establish a medium to large volume market (10,000 to 1,000,000 per year)

The most important of these tasks is to establish a market for medium to high volumes. Work done to date indicates a strong likelihood that cost and performance targets can be achieved.

ACKNOWLEDGMENT

The following have made significant contributions to the development of these coolers: W. Beale, L. Haas, D. Kiiikka, S. McDonald, G. Morris, R. Redlich, and R. Unger.

REFERENCES

1. K. McDonald, D. Berchowitz, J. Rosenfeld, and J. Lindemuth. Stirling refrigerator for space shuttle experiments, Proc. 29th IECEC, 4:1807(1994).
 2. D. Mennink and D. Berchowitz. Development of an improved Stirling cooler for vacuum super insulated fridges with thermal store and photovoltaic power source for industrialized and developing countries, Proc. IIR, "New Applications of Natural Working Fluids in Refrigeration and Air Conditioning," Hannover (1994).
 3. R. Solomon. Opportunities and problems for refrigeration in small computers, Proc. XVIIIth Int. Congr. Refr. (1991), p. 202.
 4. M.J. Deen, C.Y. Chan, and N. Fong. Operational characteristics of a CMOS microprocessor system at cryogenic temperatures, Cryogenics 28:336(1988).
 5. K.E. Wahler, Internal Report, GE Government Services, Houston, TX (June 1992).
 6. W.F. Bessler. Electrical Motor-Driven Non-Phase Change Gas-Cycle Refrigeration; Phase 1: GCR System Study and Design, Final Report, Contract 85X-SJ837C, U.S. Dept. of Energy or General Electric Corp. (June 1993).
 7. L. Sparr, S. Castles E. James, and S. Banks. Test results for a commercial, low vibration, linear, stirling cycle cryocooler," Adv. Cryogenic Engineering 44: in press (1996).
-



[Back](#) to Publications listing.

Free-Piston Rankine Compression and Stirling Cycle Machines for Domestic Refrigeration

David M. Berchowitz
Chief Engineer
Sunpower Inc.,
Athens, Ohio.

Abstract

Free-piston compressors offer the opportunity for high efficiency, quiet, low cost and oil free vapor compression. Refrigeration compatibility is reduced to the consideration of the materials from which the compressor is built. The efficiency is improved on two levels, one being the reduction of friction and the other being the possibility of modulation by simply varying the drive voltage. In principle there is no difficulty in using hydrocarbon or other environmentally acceptable refrigerants. The part count is lower which should improve reliability. For applications involving domestic refrigeration and heat pumps, the free-piston Rankine system is the most efficient system known for capacities of above about 100W when electrical energy is used. The free-piston Stirling, on the other hand, is more efficient at lower temperatures and in smaller capacities. In addition, the Stirling is quiet, possibly of lower cost and uses completely benign working mediums (either helium or hydrogen). A variant of the free-piston Stirling, called the duplex, is able to use natural gas as its energy source. This configuration has the potential for the lowest operating cost (and highest indirect efficiency) of any cooling system.

Introduction

Free-piston or linear machinery

The basic difference between free-piston or linear machinery (as they are sometimes called) and conventional rotating machinery is that free-piston devices are driven by linear motors in a resonant fashion as opposed to being driven by a rotating motor and mechanical linkage. A number of advantages immediately accrue from the resonant linear drive, namely:

- a) Side loads are vanishingly small which virtually eliminates friction and enables simple gas bearings to be used. Wear is therefore almost non-existent and oil is not required. In addition, since friction has been reduced to almost zero, the mechanical efficiency of the device is very high and internal heat generation very low.
- b) The drive system is not rigid, thus internal collisions are not catastrophic.
- c) Piston stroke is directly proportional to the drive voltage and is therefore easily controlled. This results in a simple, straightforward means to modulate the capacity and improve operating efficiency.
- d) The number of moving parts is reduced which reduces cost and improves reliability.
- e) Machining tolerances are reduced since alignment requirements are greatly ameliorated.

- f) The overall size and weight is reduced.
- g) The linear motor is easily placed within the pressure vessel making it possible to hermetically seal the device and avoid leakage of the working fluid. This is, of course, also true for small conventional compressors.

Figures 1 and 3 show respectively (in schematic form) the configuration of the linear compressor and free-piston Stirling.

Free-piston compressor

Early efforts to build linear compressors generally floundered on trying to control the mean position of the piston. Some simple linear compressors (eg, Medco Inc.) do not control the piston mean position, but simply provide enough clearance so that the piston does not contact the head under any circumstances. In order to maximize the benefit of the free-piston arrangement, the piston mean position must be continually adjusted so that a minimum dead volume exists between the piston and head at all strokes. By so doing, the efficiency is considerably maximized. Methods to do this have been successfully implemented by Sunpower and are partly responsible for the high performance of these machines.

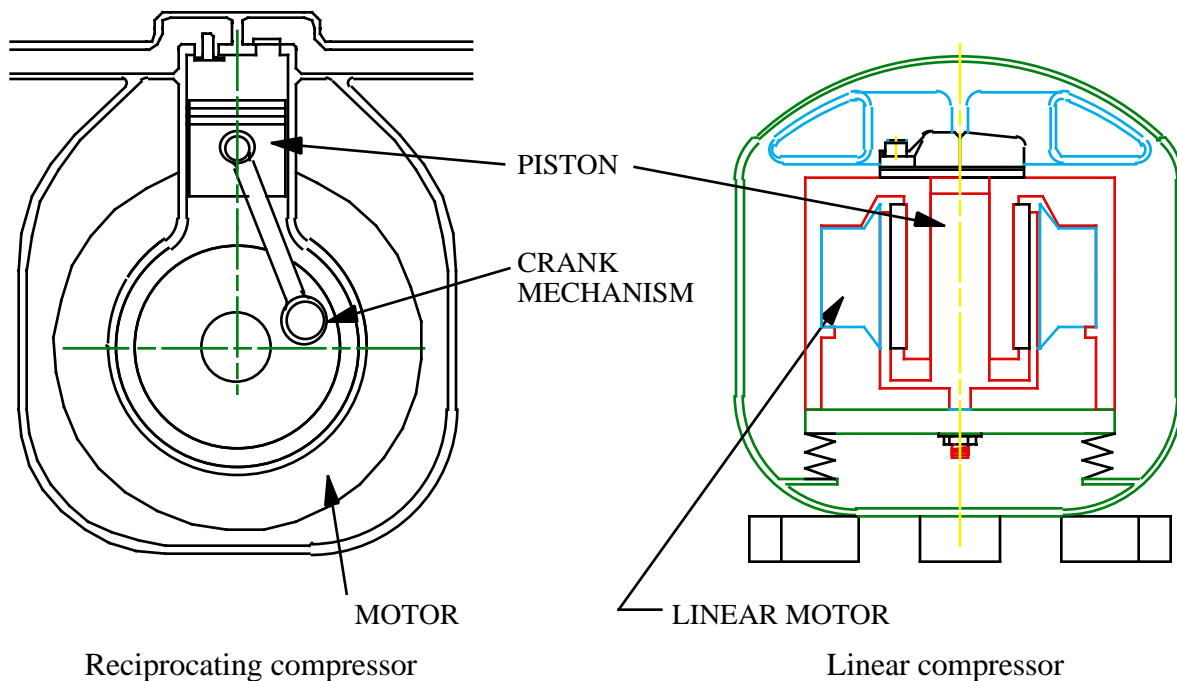

Figure 1 - Conventional reciprocating compressor compared to a linear compressor

Sunpower began investigating the linear compressor in 1991 under Environmental Protection Agency (EPA) sponsorship. A number of machines have been built and testing has been confirmed by independent laboratories. Overall, the performance has been between

15 and 23% better than typical high performance conventional machines. In addition to this, the elimination of oil lubrication allows the linear compressor to be compatible with a wide range of refrigerants. For example, some refrigerants tend to react with the lubricating oil while others are partially absorbed by the lubricating oils. Provided that the materials of construction are compatible, the choice of refrigerant is essentially unrestricted. Figure 2 shows the Sunpower prototype next to a conventional compressor of the same capacity.



Figure 2 - Prototype linear compressor (on right) compared to same capacity conventional compressor

Free-piston Stirling cooler

The Stirling cycle alternately compresses a fixed mass of gas (usually helium, but may be hydrogen or some mixture of gases) at one temperature level and expands it at another in a closed regenerative cycle in order to either lift heat or do work [1]. Originally Stirling machines were all driven kinematically, that is, by way of crank shafts and connecting rods as in most positive displacement machinery. The kinematic configurations have led to a number of problems peculiar to the Stirling, these being the contamination of the internal heat exchangers by the lubricating oil, the difficulty in containment of the pressurized working gas and the high friction in the seals due to their more severe duty. In an effort to circumvent these problems, W. T. Beale suggested the free-piston configuration shown in Figure 3 [3].

A number of prototype machines have been built by research and development companies [1,2]. In particular, Sunpower has built three versions of a 250W capacity machine for General Electric and three versions of a 60W capacity machine (Figure 4) two of which were also tested by G.E. In addition, extensive analysis has been carried out to determine the relative performance of optimized free-piston Stirling coolers operating at domestic refrigeration temperatures. It would seem that the free-piston Stirling and a high efficiency compressor would have similar optimum performance at these temperatures. The compressor performance tends to improve over the Stirling as the temperature lift (difference between warm and cold temperatures) decreases, and, as the temperature lift increases, the Stirling rapidly gains ground over vapor compression. However, relative performance seems to be related to the capacity under consideration. Small, that is, low capacity free-piston Stirlings

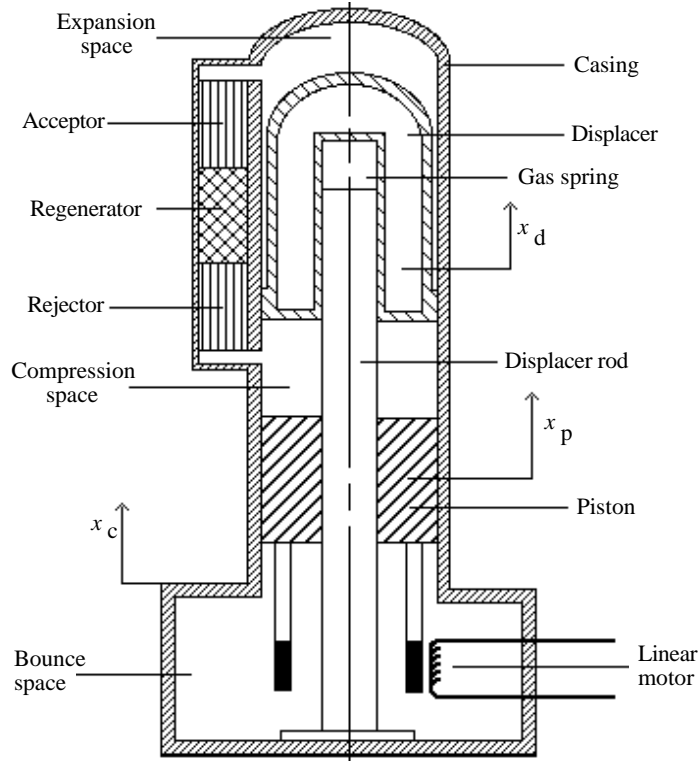

Figure 3 - Free-piston Stirling cooler

seem to retain performance better than Rankine systems do. A small refrigerator equipped with a Sunpower mini-cooler free-piston Stirling was tested by G.E. and found to consume 30% less input than current small compressor systems. Finally, since the motion of the moving parts are almost pure sinusoids, the higher harmonic content of the vibration is very small. This makes it easy to balance the machine with a simple dynamic absorber to levels of very low residual amplitude. A machine balanced in this manner is extremely quiet.



Figure 4 - Small free-piston Stirling cooler capable of cooling a 110 liter refrigerator

A proper evaluation of Stirling technology should include the duplex configuration. This machine, of which only a few prototypes have been built, consists of a free-piston Stirling engine driving a free-piston cooler by way of a common piston in a back-to-back configuration (Figure 5). The additional advantage over the basic free-piston configuration is that natural gas or other fuel source may be used to drive the cooler. Since the basic cycles are very efficient, the overall operating cost is predicted to be the lowest of all domestic cooling options [3]. In addition, the unit is compact and could be made to produce small amounts of electrical energy through a small alternator in order to power ancillary devices in the fridge. The user need see no apparent difference between a fridge so equipped and an electrically driven one. A duplex is much more efficient and much more compact than absorption devices which are the current machines of choice where heat energy is used as the input power. In fact, the overall energy usage efficiency for the duplex is high enough to be competitive in applications of low temperature lift, eg., domestic heat pumps [4].

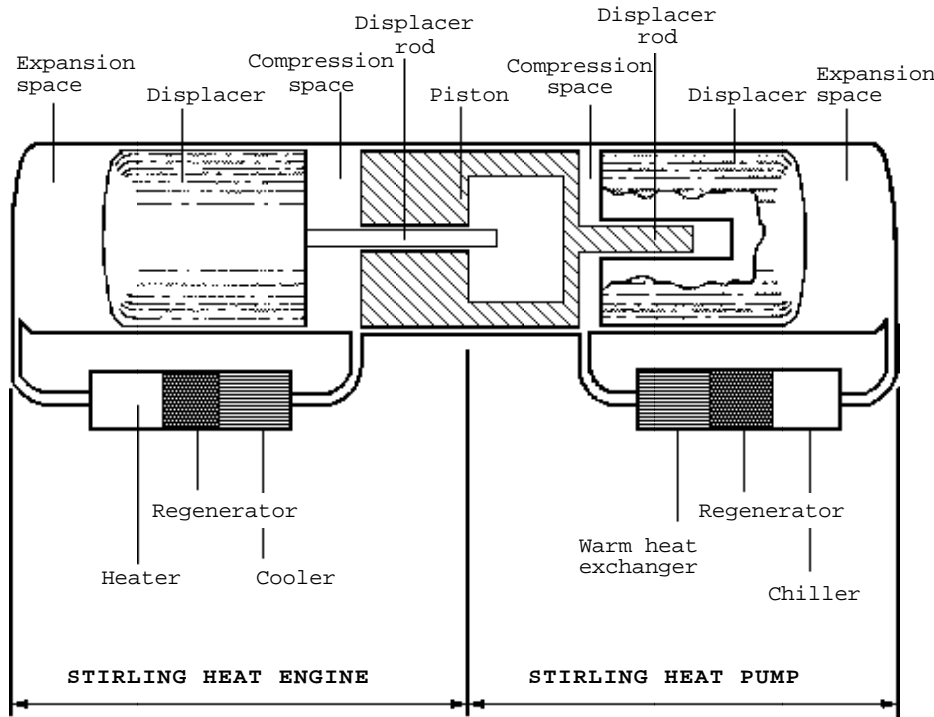

Figure 5 - (a) Schematic of Duplex Stirling.

(b) Demonstrator

Performance

Linear compressor

The performance of a modulated 250W capacity linear compressor is shown in Figure 6. For comparison, fixed point standard compressors of various capacities are shown on the same graph. In every instance, the linear compressor is of superior performance. This clearly demonstrates the ability of the linear compressor to satisfy a wide range of capacities with

one model. A smaller linear compressor of 115W capacity has also been developed and tested. At this time, only the ASHRAE performance point has been determined which showed a COP of 1.57, a full 23% better than a good conventional machine. Actually, this performance is very close to that achieved by the 250W unit when modulated to 115W lift. It is expected, however, that the smaller unit will maintain its performance better than the larger one when modulated to lower capacities. The entire domestic refrigeration requirements appear therefore likely to be satisfied by only two models, one a low capacity unit (say up to 120W) and the other a higher capacity unit (say up to 250W).

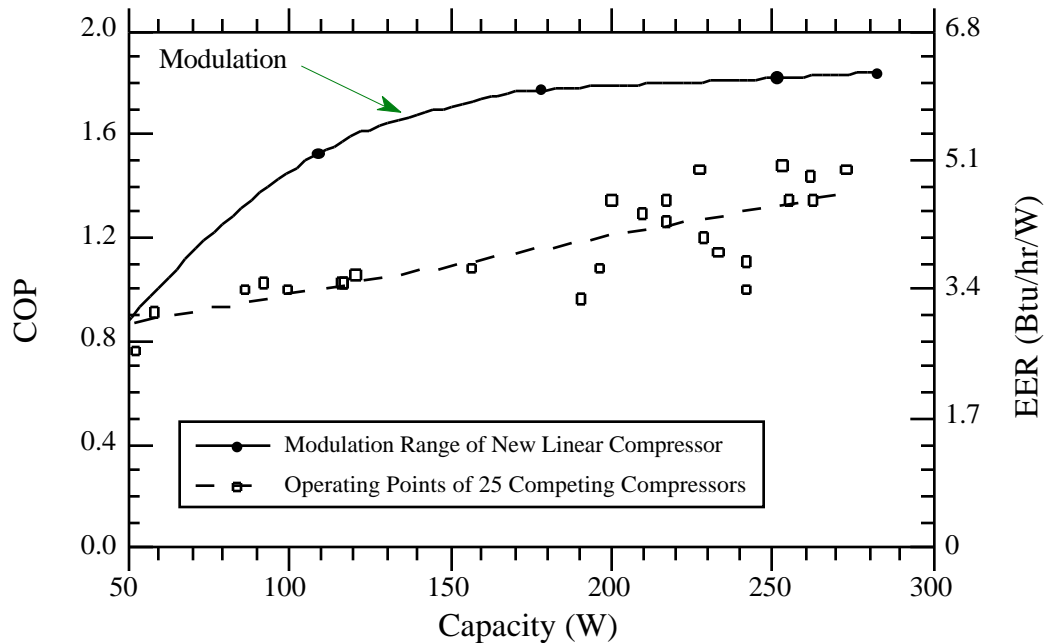

Figure 6 - Performance of modulating linear compressor compared to a number of fixed point conventional machines [7]. (COP = heat lift / total input, both quantities in Watts)

Figure 7 shows the effect of modulation on performance. Normally, a higher capacity compressor will be set up with heat exchangers designed to accommodate the higher heat transfer. When the machine is modulated to lower capacities (for example, when the refrigerator door is closed for extended periods), then the heat exchangers develop smaller differential temperatures since they become more lightly loaded. This tends to improve the overall performance to higher levels than that predicted by simply operating at the standard ASHRAE set point rating condition. In addition to this, continuous modulation avoids the losses associated with re-establishing the thermodynamic cycle every time as is required in the conventional stop-start modulation. Modulation thus tends to have a multiplying effect on performance over and above the simple set-point advantage that the linear compressor demonstrates over conventional compressors.

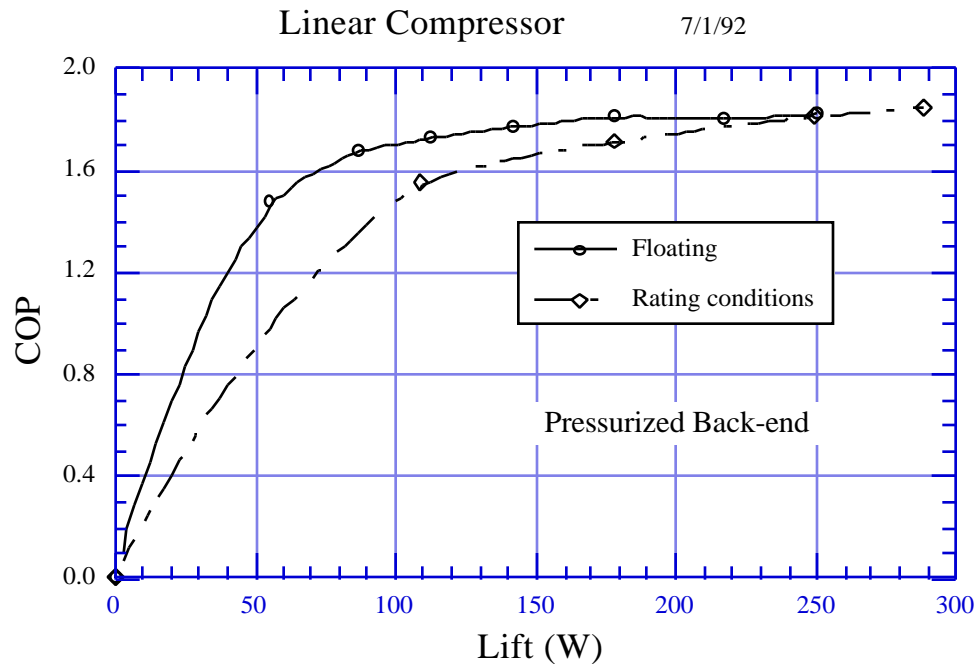

Figure 7 - Advantage of modulation on performance

Free-piston Stirling cooler

The Stirling units are not developed to the same level of performance as the linear compressor. So far, the best performance in the higher capacity units is about 32% of Carnot which translates to a COP of about 1.3. This is shown in Figure 8. All the same arguments concerning modulation apply equally to the Stirling. Theoretically, an optimized 200W capacity Stirling would be expected to have roughly the same performance as an efficient linear compressor system [5]. However, the Stirling appears to scale better to smaller sizes than does compressor systems. A number of *in situ* tests have been conducted at both G.E. and Sunpower on smaller units (60 to 110 liter refrigerators). These tests have shown that a small free-piston Stirling equipped fridge is at least 30% better in performance than current vapor compression units. Since then, a small hydrogen charged Stirling has been bench tested and found to be some 50% better in performance than the earlier helium charged prototype (Figure 9). It is expected that once tested in a small refrigerator, the hydrogen charged unit should show equivalent heat lift at better than 60% savings in input over the original equipment. The use of hydrogen is not seen as an impediment to safety. The gas inventory is small and pure hydrogen need not be used.

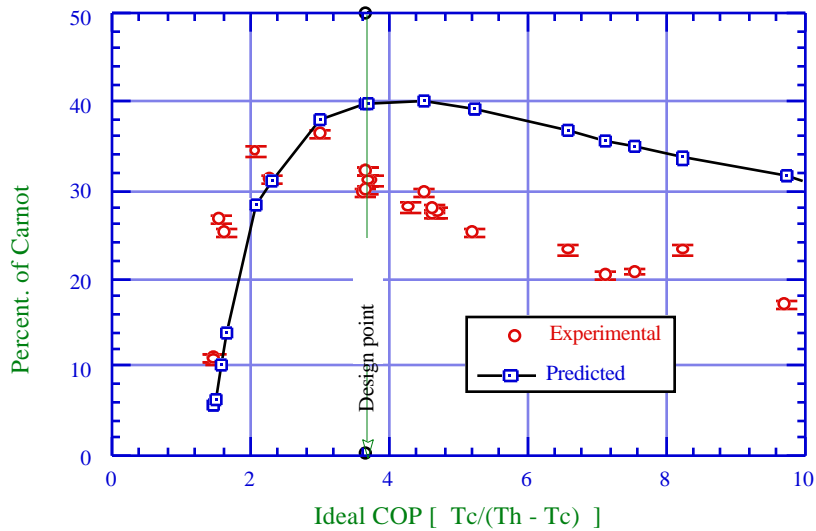

Figure 8 - Percentage of Carnot (or ideal performance) vs. Ideal COP for lifts between 200W and 257 W (includes motor losses)

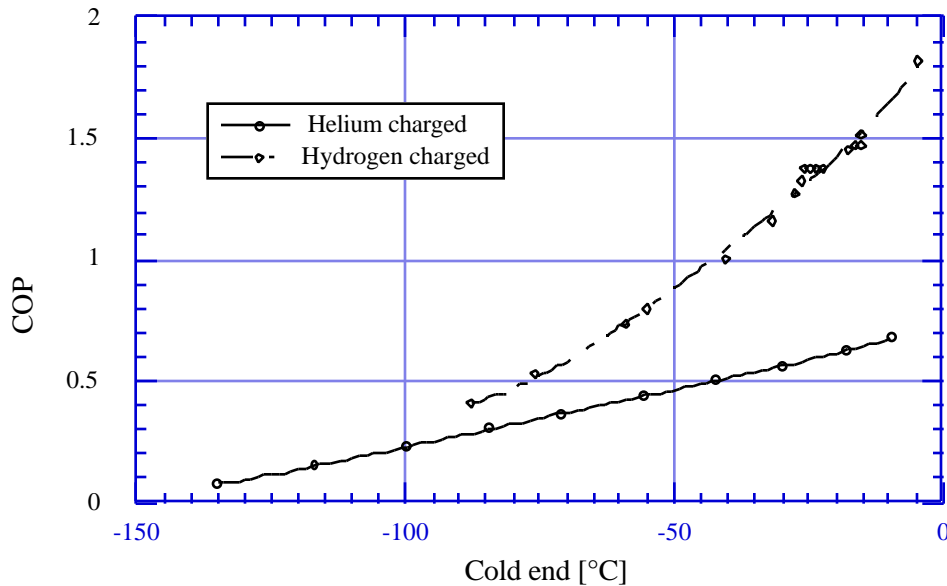

Figure 9 - Comparison between hydrogen and helium charged small Stirling coolers (includes motor losses)

Experimental performance of duplex machines is only available for a few technology demonstrator prototypes and is not really useful in determining the potential of this device. Instead, a study has been conducted where modest performance for the engine and cooler sections were assumed and, together with typical combustor efficiencies, an overall performance estimate has been calculated [3]. Figure 10 shows the results of this exercise and compares the estimated operating cost to that of a conventional compressor operating at

identical conditions. Both systems are assumed to be running continuously and lifting 250W. Based on these numbers, the duplex refrigerator would have operating costs of between 61 and 46% less than the vapor compression system. Since this data was generated, likely improvements in compressors will reduce this advantage to between 46 and 24% which is still a very substantial savings. Continuous modulation is likely to give further advantage to the duplex since the on/off cycle losses associated with the vapor compression system is an additional burden.

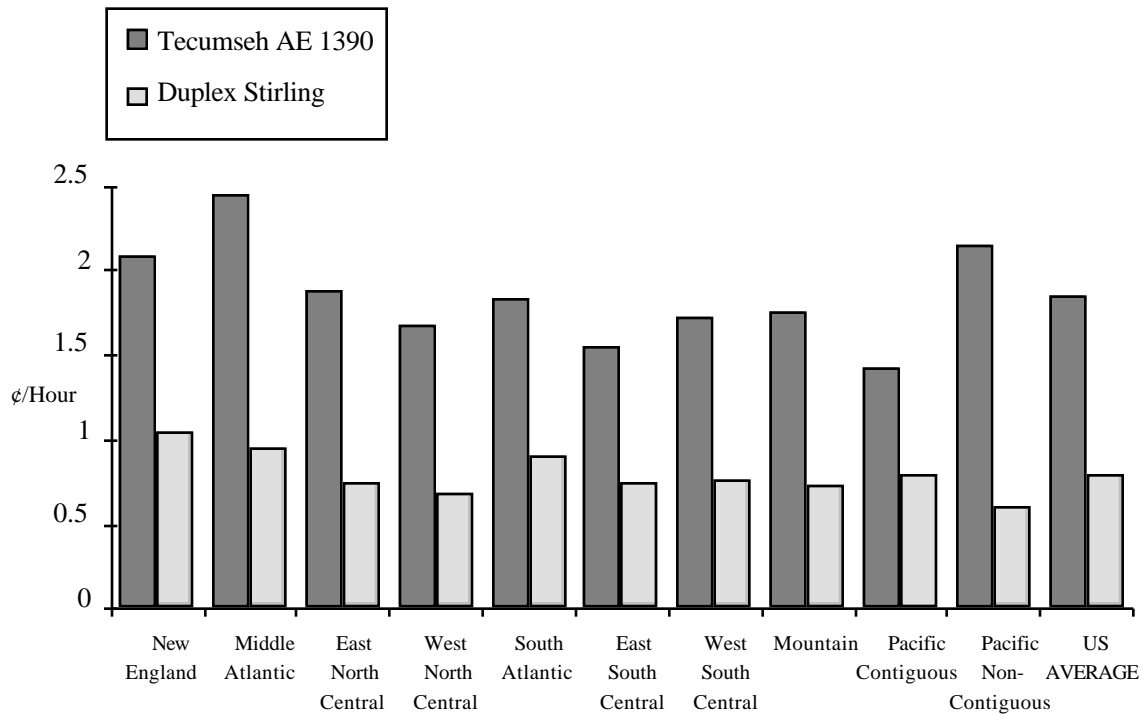

Figure 10. - Relative operating costs for the duplex [6]

Comparisons of the duplex to absorption cycle devices is also relevant since both systems use natural gas for primary energy. Based purely on energy usage, a thermally optimized absorption system [9] uses between 15 and 25% more energy than the duplex for the same duty. This comparison excludes modulation or likely improvements in the duplex.

Costs

Linear compressor

At this time a formal production cost estimate has not been completed. However, it is clear that the number of moving parts has been reduced as well as the number of close toleranced parts. Furthermore, the construction of the linear motor is much simpler than conventional motors and no expensive oils are required. Currently, permanent magnets are used in the linear motor. In principle, a wound field motor may be used but this would be of larger mass. Modulating the unit requires some electronics of differing complexity depending

on the technique employed. Actually, it is possible to reduce the electronics to very simple sensing circuits not too different to that used in some refrigerators today. Given the foregoing, it would appear that linear compressors should be much cheaper than high performance, multiple speed crank-driven machines. How it stacks up against the new scroll compressors would depend to a large extent on the simpler components of the linear compressor and the fact that no oil is required.

Free-piston Stirling cooler

General Electric has done a formal costing of a 200W capacity refrigerator cooler [5]. Their numbers are very favorable towards the Stirling, being about \$88/unit in quantities of 250,000 which is about twice the cost of current mass produced systems. With some cost reduction engineering and quantities of a million or more per year, the cost drops to only \$30/unit which is very competitive. A further point is that the magnet assembly comes out at 24% of the total cost. With the continued fall in magnet prices plus the pressure of competitive bidding, the final production cost may even be lower. Investment and tooling costs were estimated at about \$20 million. The smaller units have not been costed for this kind of production. However, it is likely that the cost advantage improves at the smaller sizes owing to the way the heat exchangers scale with respect to capacity. The duplex has also not been costed. But here again, the machine is basically very simple but needs a small high efficiency combustor. The motor size is greatly reduced and may even be eliminated if no electrical energy is required. Certainly, comparing the duplex to an absorption system, the duplex is much more compact and of less mass.

Summary

Linear machinery offer flexibility and performance advantages over conventional rotating crank systems. For the application considered here, namely domestic refrigeration, a strategy for optimum performance may be as follows:

- a) Linear compressors for lifts above around 100W and where there is an overriding desire to use electricity.
- b) Free-piston Stirling coolers for lifts below about 100W (exact cross over point has not been determined - may be as high as 200W). Higher capacities are competitive for lower temperatures (eg, deep-storage freezers). Again where electricity is used.
- c) The duplex for all applications and lifts where operating cost is the most important criterion and natural gas is available.

Product costs definitely favors free-piston machinery over conventional machines for equivalent performance (where that can be achieved by conventional machines). Of the linear machines, product cost may favor the Stirling at the lower capacities. However, product costs may turn out to be similar so the overriding criterion may be operating cost

savings which translate into performance.

Of these technologies, the linear compressor is the most developed followed by the small free-piston Stirling cooler. The duplex, which shows the most overall potential, is essentially undeveloped but proven in principle. Free-piston Stirling engines and coolers of appropriate sizes have been run, and individually have demonstrated that if combined would easily produce the performance estimated here.

Acknowledgements

The engineers responsible for the linear compressor work are R. Unger and N. van der Walt.

References

- 1 Berchowitz D.M. and Bessler W.F., "Progress on Free-Piston Stirling Coolers", Proc 6th Int Stirling Engine Conf, Eindhoven, Netherlands, May, 1993.
- 2 Walker G *et al*, "Stirling, Near-Ambient Temperature Refrigerators: Innovative Compact Designs", Proc 27th IECEC, Paper # 929035, August, 1992.
- 3 Berchowitz D.M. and Shonder J., "Estimated Size and Performance of a Natural Gas Fired Duplex Stirling for Domestic Refrigeration Applications", Proc. of the XVIIIth Int Cong of Refrigeration, pp 1350-1354, 1991.
- 4 Chen G. and Beale W.T., "Thermally Actuated Duplex Free-Piston Stirling System for Domestic Cooling and Heating Applications", Int Conf on CFC's and Halon Alternatives, Beijing, China, April 20-23, 1993.
- 5 Bessler W.F. "Electrical Motor-Driven Non-Phase Change Gas-Cycle Refrigeration, Phase I: GCR System Study and Design", GE-DOE Final Report, Contract 85X-SJ837C, June 1993.
- 6 Fabien M.J. and Berchowitz D.M. "Stirling Refrigeration Cycle Development Phase I: Scoping Study and Feasibility Analysis of the Free-Piston Stirling Cooler", ORNL/CON - In Process of Being Published - Number To Be Determined, © 1991.
- 7 van der Walt N.R. and Unger R. "The Simulation and Design of a High Efficiency, Lubricant Free Linear Compressor for a Domestic Refrigerator", *International Compressor Engineering Conference*, Proceedings, Vol 1, pp 1-9, Purdue University, July 1992.
- 8 Beale W.T. *et al*. "Design of Energy Efficient Linear Motors / Compressors", EPA Prime Contract 68-D90068, Final report, Sunpower Inc., March, 1993.
- 9 Trines R. and Heijnen P. "Improving Efficiency in Domestic Refrigeration Units in the Netherlands", CADDET Newsletter, No 3, Sittard, The Netherlands, Sept 1993.

Stirling Refrigerator for Space Shuttle Experiments

Kelly McDonald
Martin Marietta Services, Inc.
David Berchowitz, Ph.D.
Sunpower, Inc.
John Rosenfeld, P.E.
James Lindemuth Thermacore, Inc.

Presented at the 29th Intersociety Energy Conversion Engineering Conference, Monterey, CA
August 7-11, 1994.

Abstract

In October 1992 Martin Marietta Services was tasked by NASA's Life Sciences Projects Division at the Johnson Space Center to design and develop an Orbiter Refrigerator/Freezer (OR/F) based on a Stirling cycle cooler. OR/F's are used in the Shuttle mid-deck to store experiment samples, primarily blood and urine.

The Stirling Orbiter Ref/Frzzr (SOR/F) uses a horizontally opposed Stirling cooler designed by Sunpower, Inc. of Athens, OH. The cooler is lightweight and efficient, and uses helium as the working fluid instead of a CFC. A pair of acetone heat pipes is used to transfer heat from the cold volume to the cooler where it is rejected to cabin air. The heat pipes do not require a pump or electronics, which helps to keep the overall system simple and efficient. The heat pipes were developed by DTX/Thermacore, Inc. of Lancaster, PA. The SOR/F also utilizes a new insulation, precipitated silica. The improved insulation allows for a reduction in cooler size.

The SOR/F has a total lift of greater than 85W (net lift 55W) at -22°C and uses 70W input power. Besides meeting its thermal specifications the SOR/F meets another primary design goal: it reduces acoustic noise. The unit has operated for over 600 hours and was flown successfully aboard STS-60, SpaceHab 2 in February 1994.

Introduction

Refrigerator/Freezers are currently used on board the Space Shuttle to support science experiments. Life Sciences missions depend heavily on the ref/frzr's for the preservation of urine, blood and saliva samples. The SOR/F project was initiated to develop a replacement to the existing OR/F's. The unit is the size of two mid-deck lockers, weighs 45.8 kg (101 lbs.) and is supplied with 28 VDC. It must maintain a cooled volume of 0.3 m³ (1.2 ft³) between 10° and -22°C and provide 50 W of net lift. An emphasis was also placed on meeting the Orbiter payload acoustic specifications. While operation during ascent is not required, it was decided that the Stirling cooler would remain operational during this period in order to simplify the design. The SOR/F consists of three major subsystems: the Stirling cooler, a pair of acetone heat pipes and the cold volume. Detailed requirements are available in the Specification and Assembly Drawing (LS-30106).

Stirling Cooler

The Stirling cycle alternately compresses a fixed mass of gas (usually helium) at one temperature level and expands it at another in a closed regenerative cycle in order to either lift heat or do work. The thermodynamic cycle is covered in more detail elsewhere (1, 2, 3, 4). Suffice it to say that in its ideal form, the Stirling cycle has the highest possible efficiency of any thermodynamic cycle. The particular configuration used here (Figure 1) is an opposed free-piston machine which offers advantages in reliability, quietness of operation and simple capacity modulation. This machine is a modification of the Sunpower Minicooler originally developed for cooling electronics (5).

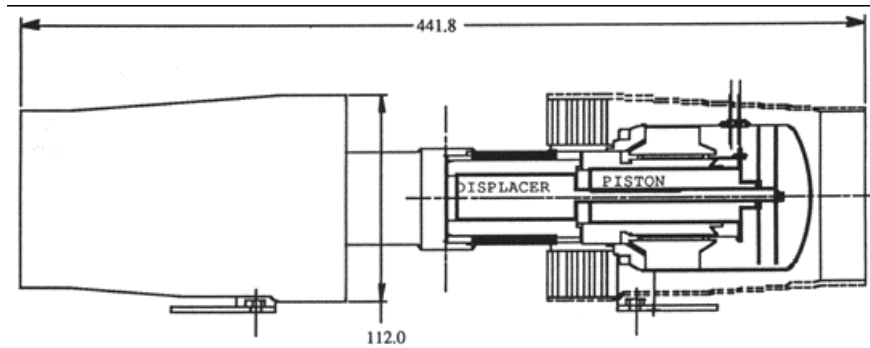

Figure 1 Opposed Free-Piston Stirling Cooler (Dimensions in mm)

Basic Design Requirements

- 124W of lift at 4°C box temperature and 88W at -22°C box temperature. Ambient in both cases is 23°C. A temperature difference of 12°C was assumed between the box temperature and the Stirling cold end.
- Maximum temperature of the air at the rejector exits is not to exceed 49°C.
- Maximum inaccessible surface temperatures are to be below 49°C during normal operation.
- Must operate in ambient conditions from 5°C to 35°C.
- Voltage supply is 28 VDC \pm 4 VDC. Consumption may not exceed 300W intermittent and 200W continuous.

Description

Two modified Minicoolers were arranged in an opposed configuration. By operating the machines 180° out of phase, all else being equal, the residual casing vibrations are nulled. In practice, the machines do not operate in identical modes. There is always some discrepancy in amplitudes and phases between the moving parts. These discrepancies result in a residual casing vibration. Therefore, in order to obtain the lowest vibration levels, circuitry was provided to alter the input to one linear motor with respect to the other. By adjusting the relative voltage and phase between the two drive voltages, it is possible to achieve extremely low vibration levels. This adjustment was made manually as part of the final tuning of the system. For the application at hand, an active vibration control system was seen as unnecessarily elaborate since the only purpose of minimizing vibration was to control noise. An additional advantage of the opposed configuration is that, for the same levels of residual vibration, it has a much better specific capacity (Lift/Mass) than a single sided machine owing to the absence of the balance mass.

Additional modifications included improving the reliability of the motors and reoptimizing the heat exchangers for higher efficiencies at warmer temperatures. About forty units of the Minicooler have been fabricated and extensive operating experience has been obtained. This has made it possible to calibrate the design calculations to a high level of confidence.

The electronic package consists of the driver section which is responsible for supplying the motors with pulse width modulated square waves. Modulation of the cycle is achieved by controlling the piston amplitudes which is proportional to the RMS drive voltages. The control circuit determines an error signal between a user set temperature and a measured temperature and adjusts the drive voltages to minimize the error. The system therefore responds to

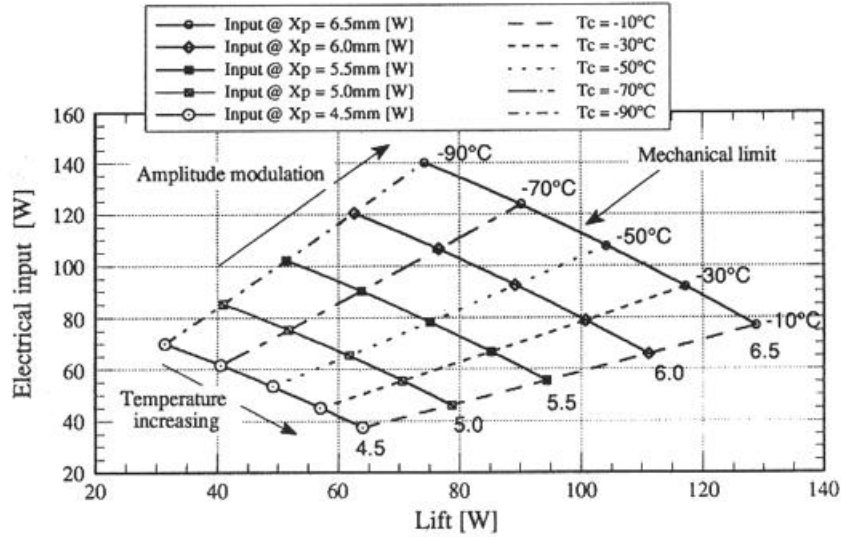

Figure 2 Calibrated Calculation of Performance Map (Reject Temperature Fixed at 45°C)

temperature variations in the cold space by adjusting the amplitudes of the pistons. If the temperature in the cold space is constant, then the cooler adjusts its lift to just balance the heat leak. This temperature control system minimizes cycle losses and therefore input. If the motor temperatures exceed a set value, then the temperature control is overridden and the drive is essentially switched off. Signal points for motor currents and various temperatures are provided for observation and data down-link.

Analysis

The analysis of the cooler follows that outlined in [4]. In its simplest form, the cooler may be described as a tuned mechanical oscillator where the resonances of the displacer and piston are designed so as to obtain optimum phase angles for both thermodynamic and electrical performance. The flow conditions within the cooler are somewhat chaotic and precise analysis is intractable even though the response of the system is remarkably linear [6]. Generally, a combination of approaches including oscillatory flow models, non-steady heat transfer and empiricism has proved to be successful in predicting the performance of these machines. Figure 2 shows the calculated performance map which includes the losses associated with the linear motors. The cold-side and warm-side temperatures are assumed to be measured on the outside walls of the acceptor and rejector respectively. In practice, the warm side temperature is proportional to the rejected heat and therefore varies with load and setpoint temperature. For the purposes of this graph, the warm-side is assumed fixed at 45°C, which is typical of the reject temperature at the higher capacities. Especially interesting from Figure 2 is the cooler's ability to maintain a reasonable capacity and efficiency over a wide range of operating temperatures.

Figure 3 shows the linear motor performance as calculated. Bench tests which determine the total AC resistance and the motor constant (Volt-seconds) verify that the performance follows the predicted map. Discrepancies at the lower powers are more likely owing to the difficulty of determining the effects of structure on fringe losses,

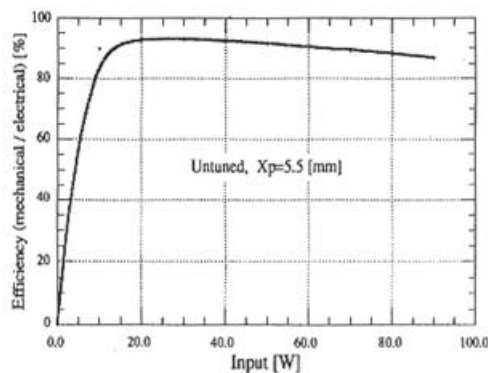

Figure 3 Linear Motor Calculated Efficiency at Design Amplitude (input per side)

Bench testing

Figure 4 shows actual performance as measured on the bench. These data were taken from the third unit built in a batch of three. Inputs appear to be some 10 W higher than anticipated. From subsequent work, it is now known that part of this is due to center-port and gas bearing losses.

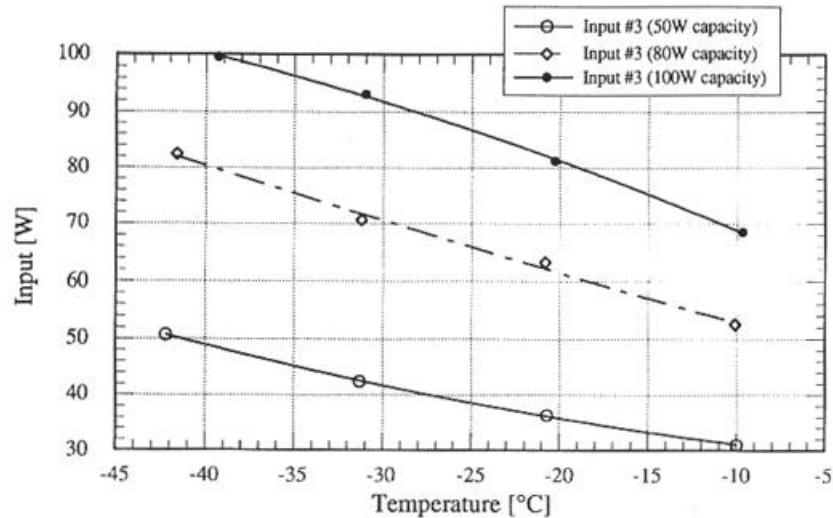

Figure 4 Actual Performance as Measured on the Bench

It is possible to reduce both of these losses to less than a few Watts by reducing the center port activity and bearing stiffness. A less significant loss is that due to the dissipation of higher harmonic currents in the motors. These harmonics are generated by the square wave driver. A sine-wave driver would eliminate harmonic losses. Other testing activities included voltage tolerance, response to load changes and vibration levels. Balancing achieved vibration amplitudes of less than 10 (m amplitude as measured on the axis).

Acetone Heat Pipes

Thermacore designed, fabricated and tested a heat pipe heat transport system for the SOR/F. This system used a pair of copper/acetone heat pipes to remove heat from the refrigerator's cold volume and transfer it to the cold end of the Stirling cooler. Figure 5 shows the external design of the heat pipe system. Since the design required the heat pipe system to transport at least 106W at -60°C and 156W at 20°C, the SOR/F application challenged heat pipe technology. For this application, a porous metal wick was selected because alternative wicks such as axial grooves would not have the capillary pumping capability required to stay operational during launch acceleration loading.

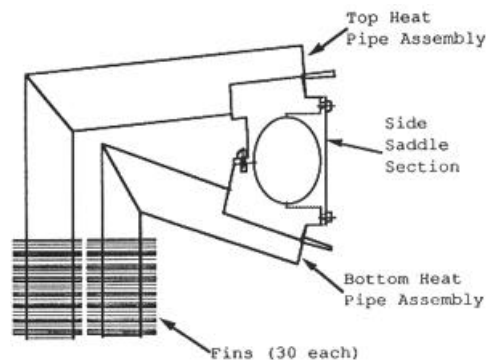

Figure 5 Heat Pipe System

The heat pipe system consisted of one top heat pipe assembly, one bottom heat pipe assembly, and one side saddle. The top heat pipe consisted of a 3.81 cm (1.50") outer diameter copper tube, a miter bend of 94°, and a total centerline length of 37.08 cm (14.6"). The evaporator and condenser wick structures were sintered copper powder wicks, with sixteen 0.32 cm (0.125")

diameter flexible copper cable arteries connecting the evaporator and condenser wicks. The bottom heat pipe consisted of a 3.18 cm (1.25") outer diameter copper tube, a miter bend of 75°, and a total centerline length of 21.16 cm (10.3"). The evaporator and condenser wick structures were sintered copper powder wicks, with twelve 0.32 cm (0.125") diameter flexible copper cable arteries connecting the evaporator and condenser wicks. Thirty copper fins and the top and bottom saddle section were soldered to the evaporator and condenser outer surfaces. The fluid charges of the top and bottom heat pipes were 87 and 49 grams of high purity acetone, respectively. The side saddle section was also fabricated from copper, and was bolted to the top and bottom saddle sections.

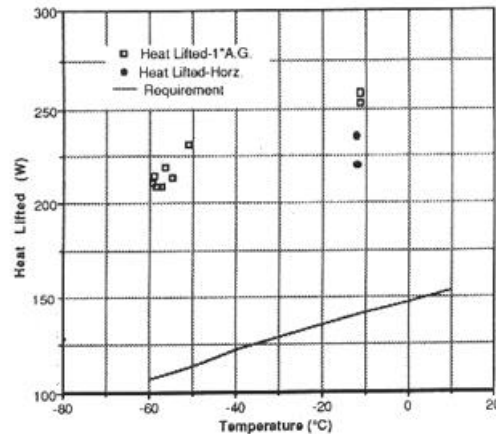

Figure 6 Cold Head Temperature vs. Total Lift

The heat pipe system met and exceeded the needs of the SOR/F application. Ground testing of the system showed that the heat pipes were capable of transporting 220W of power against gravity near -50°C and 260W of power against gravity near -10°C. Figure 6 shows the data collected during ground testing of the system.

Cold Volume Assembly

In a departure from past practice it was decided that the cold volume would not be constructed out of aluminum. Instead, a vacuum formed Lexan enclosure was designed. The cold volume is connected to the frame assembly by glass filled epoxy brackets. This design provided the required volume and reduced the amount of heat leak due to conduction through metal support brackets. The reduction in heat leak in turn allowed the use of a smaller Stirling cooler. The volume is insulated with no less than three layers of precipitated silica packets. The packets were developed by General Electric and manufactured by Derby Industries of Louisville, KY. The conductivity of the packets is 0.006 W/m-K as compared to 0.016 W/m-K for the poured urethane foam that was previously used. The door seal was designed with two gaskets to decrease heat leaks through the door opening. Heat leak tests were performed at the system level. At an internal temperature of -22°C the unit has a K factor of 0.53W/°C. Past units had K factors of 0.8W/°C, so this system represents a significant improvement.

System Integration

The assembly of the SOR/F subsystems went smoothly. Poured foam was used to insulate the exposed portion of the heat pipes and the Stirling cold end. Prior to delivery the SOR/F underwent functional, performance, and environmental testing. Environmental testing included vibration (random and sine sweep), acoustic and EMI. The unit passed acoustic testing, which had been a major design goal.

Performance testing of the SOR/F revealed that the unit could lift 90.6W at 4°C and 88.5W at -22°C. As previously mentioned, the heat leak factor was 0.53W/°C and the fans dissipated 10.2W, so at both refrigerator and freezer conditions the unit lifted more than 55W net. The average power consumed at 4°C is 60W and at -22°C is 70W.

The unit was first flown on STS60, the SpaceHab-2 mission. It was installed on the aft wall of the SpaceHab module prior to module integration and was activated as a freezer two days before launch. The unit was loaded with ice cream at L-24 hours at the crew's request. Down link from the SOR/F was not available until SpaceHab activation (about 100 minutes into flight), but temperature readings from a data recorder in the cold volume indicate the unit performed nominally during ascent. The flight test showed the capability of porous metal wick heat pipes to operate in the adverse accelerations imposed during launch and in microgravity. The crew used an activity log to record the removal and storage of contents throughout the mission. There were fifteen door openings during the three days of operation as a freezer and nine door openings during the four days as a refrigerator. Data from the door openings show the expected. After the door is closed the motor currents increase to bring the temperature

below the set point. The internal temperature returns to set point within the required time, four minutes. The unit worked well even when cabin conditions reached 26.7°C and 41% relative humidity. During a tour of the SpaceHab, astronaut Franklin Chang-Diaz commented how they have enjoyed the SOR/F contents and how well it worked.

Summary

The SOR/F has proven to be a capable replacement to the existing OR/F's. The use of the Stirling cooler and heat pipe assembly increased system level efficiency and reliability and decreased acoustic noise and maintenance requirements.

References

1. Walker G. Cryocoolers, New York: Plenum Press, 1983.
2. Berchowitz D.M. and Shonder J. "Estimated Size and Performance of a Natural Gas Fired Duplex Stirling for Domestic Refrigeration Applications", XVIIIth International Congress of Refrigeration Inc., Montreal, Canada, August 1991.
3. Beale W.T. "Free-Piston Stirling Engines - Some Model Tests and Simulations", SAE Cong, Detroit, MI, Jan. 13-17, 1969. Also SAE paper 690230.
4. Berchowitz D.M. "Free-Piston Stirling Coolers", International Refrigeration Conference - Energy Efficiency and New Refrigerants, Purdue University, July 1992.
5. Berchowitz D.M. "Miniature Stirling Coolers", NEPCON - East '93, Boston, MA, June, 1993.
6. Redlich R.W. and Berchowitz D.M. "Linear Dynamics of Free-Piston Stirling Engines", Proc Instn Mech Engrs, Vol. 199, No A3, March 1985, pp. 203-213.

ESTIMATED SIZE AND PERFORMANCE OF A NATURAL GAS FIRED DUPLEX STIRLING FOR DOMESTIC REFRIGERATION APPLICATIONS

by

D.M. Berchowitz and J. Shonder

Calibrated calculations are used to size an integrated Stirling cooler and engine (Duplex configuration). Fuel for the engine is natural gas and the working fluid is helium. The potential exists for long life and low noise. Performance is shown to be very competitive when compared to standard vapor compression systems.

Free-piston, Stirling, Non-CFC, Domestic refrigeration,
Natural gas fueled

ESTIMATED SIZE AND PERFORMANCE OF A NATURAL GAS FIRED DUPLEX STIRLING FOR DOMESTIC REFRIGERATION APPLICATIONS

D. M. BERCHOWITZ

Sunpower Inc.,
Athens, Ohio 45701, U. S. A.

J. SHONDER

Oak Ridge National Labs.,
Oak Ridge, Tennessee, U. S. A.

1. INTRODUCTION AND BACKGROUND

The concern with the destruction of the ozone layer by chlorofluorocarbon compounds (CFCs) has prompted renewed interest in alternative refrigeration cycles. One of these cycles is the free-piston Stirling which appears to offer comparable, if not better, performance to the vapor compression cycle [1]. It is, however, possible to greatly improve the competitiveness of the Stirling by casting it in the Duplex configuration. The Duplex involves two free-piston Stirling cycle machines in a back-to-back configuration (Figure 1) [2]. One machine operates as an external combustion heat engine and drives the other by way of a common piston which then operates as a heat pump. By this means it is possible to operate the refrigerator on various fuels which may have economic and/or environmental benefits. This concept was first tested in hardware in 1979 when a small number of demonstrator units were built, one of which is shown in Figure 2. Since then some larger prototypes have been assembled for applications such as natural gas liquefaction and residential heat pumping [3]. In the refrigeration application, it is envisaged that natural gas would be used to fuel the engine while the heat pump removes heat in order to refrigerate food stuff. A regenerative combustor is used which ensures high combustion efficiency, low emissions and low exhaust temperatures.

The Duplex Stirling appears to be an attractive proposition for domestic refrigeration for the following reasons:

- i) No chlorofluorocarbons – the working fluid is usually helium.
- ii) Fuel source is natural gas.
- iii) Operating costs for same capacity is strongly competitive with conventional electrically driven vapor compression units.
- iv) Uncomplicated, only three moving parts.
- v) Compact. Not much larger than a vapor compression unit of similar capacity.
- vi) High reliability and long life is expected since the unit is hermetically sealed and, in addition, component side loads are very small allowing for the implementation of non-contact gas bearings.
- vii) Very low noise and vibration owing to low pressure combustion and the ability to completely balance the machine.
- viii) It is also possible to generate a small quantity of electrical energy to power the internal

light and other accessories.

- ix) Continuous modulation is easily implemented should there be an advantage in doing so. Free-piston Stirling machines tend to retain high efficiencies at part power much better than their internal combustion and vapor compression counterparts.

The purpose of this paper is to present the expected thermodynamic performance of such a system, evaluate operating cost scenarios and discuss the state of the art.

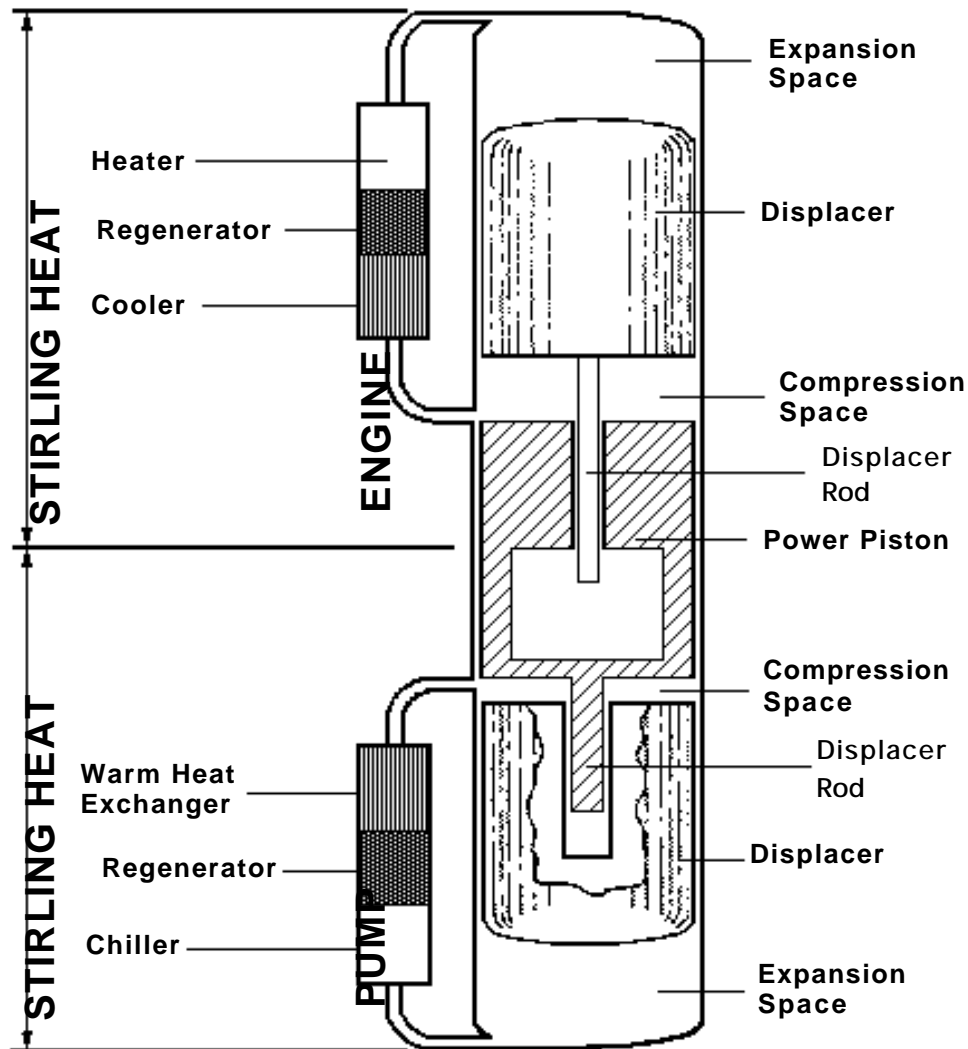

Figure 1 – Schematic of Duplex Stirling machine

2. BASIC THEORY

The Stirling cycle is a closed cycle in which a fixed mass of gas is alternately expanded, warmed/cooled, compressed and cooled/reheated to the beginning of the expansion phase. Whether the gas is warmed or cooled after expansion and cooled or reheated after compression depends respectively on whether the cycle pumps heat or produces power. Figure 3 shows the two most common configurations for realizing the Stirling cycle. The

processes of heating and cooling are appreciably augmented by the regenerator which generally consists of a matrix of fine wires or simply annular gaps made by winding foil on itself. The regenerator serves to store heat as the gas leaves the warm/hot section and to transfer this heat back to the gas as the gas returns from the cold section. Sensible heat is mainly transferred internally by the regenerator and the compression and expansion processes are therefore able to approach isothermal operation which allows high efficiencies to be obtained.



Figure 2 – Duplex demonstrator machine with recuperative combustor, note ice formation on cold end.

The free-piston configuration of the Stirling cycle is a novel arrangement in which the moving parts are driven by the gas pressure forces within the machine rather than the more conventional crank mechanisms. In order to achieve the proper motions, a differential area must be provided across the displacer. Figure 1 shows one method of achieving this by the use of a displacer rod. The operation of a free-piston engine may be understood by describing the pressure forces as the cycle goes through its motions. Beginning at the compression stage, as the piston moves up it increases the pressure in the engine side and decreases the pressure in the heat pump side. This creates a force on the displacer because of the presence of the rod which pushes the displacer towards the compression space thus effecting the constant volume displacement of the gas to the hot side.

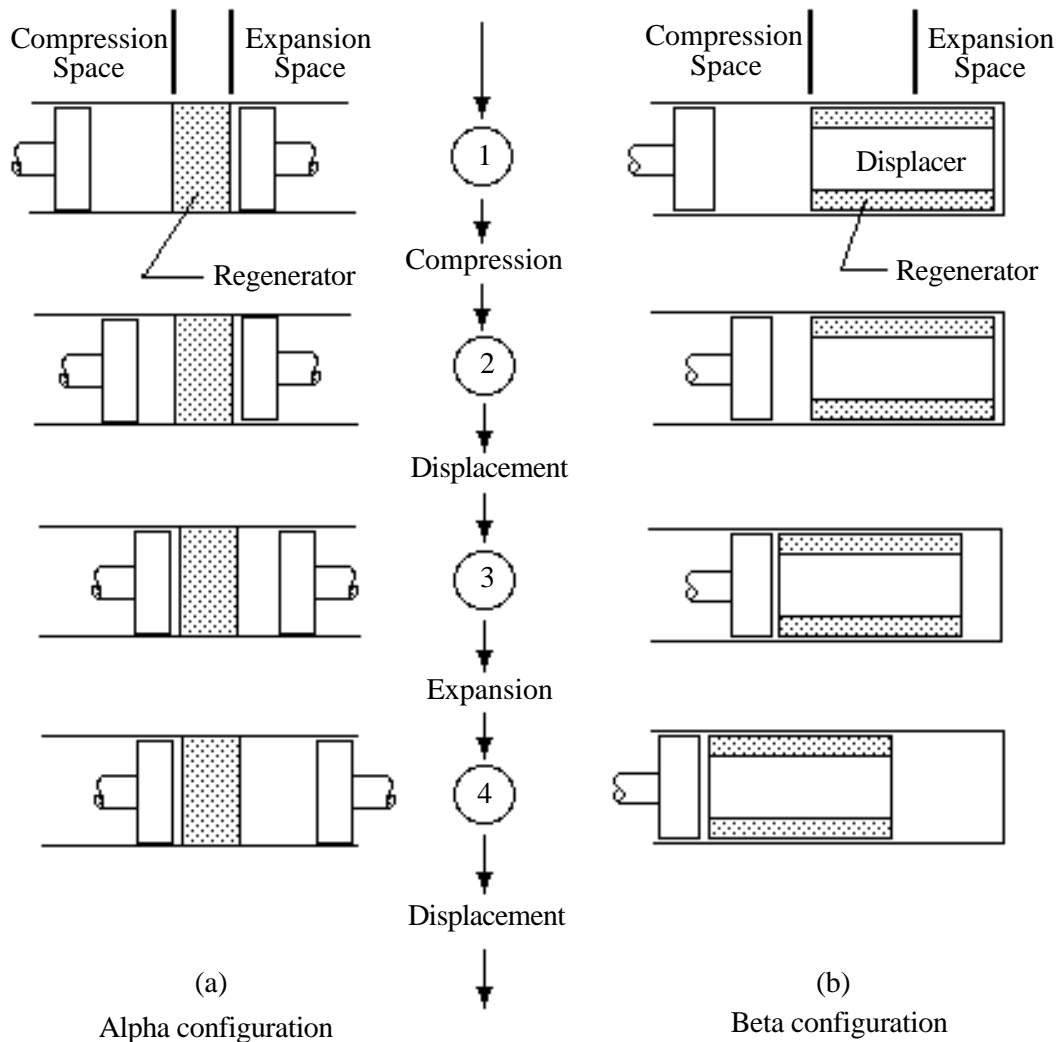

Figure 3 – Piston and displacer motions for two common configurations.

The pressure is now further increased by the arrival of the gas at the hot end and this begins to force the piston out and produce work. Because of the piston's inertia, it overshoots the equilibrium pressure to expand the gas to a lower pressure. In so doing the piston again creates a pressure force across the displacer which now forces the displacer towards the hot end, displacing the gas to the cold end which is the beginning of the cycle. The cooling cycle operates on the same principle except that in this case it is necessary to supply power to the piston. Steady operation of the Duplex is achieved when the developed power is exactly absorbed by the cooler section. Since the piston and displacers are freely moving components and the appropriate phase angle between their motions is important for the production of power and the lifting of heat, it is necessary to spring the moving parts so that they operate correctly at the required frequency. Linear dynamics theory [4, 5, 6] has been found to adequately describe the behavior of these machines and allows the determination of all the important parameters for optimal operation. The engine performance presented here has been obtained from such an analysis.

3. COMPONENT EFFICIENCIES AND GENERAL ARRANGEMENT

It is assumed that the heat pump or cooler section would be essentially identical to the prototype cooler built and tested at Sunpower and described fully in a companion paper [7]. The Sunpower free-piston Stirling cooler is driven electrically by way of a linear motor. For use in the Duplex configuration, the linear motor would, of course, be replaced by a free-piston Stirling engine of similar output power. Since the piston is levitated by gas bearings and is common to both the engine and the cooler, the mechanical efficiency of the linkage is extremely high. For the purposes of this work it is taken as 100%. The source and sink temperatures to which the Stirling is subjected would be somewhat different to those associated with a typical vapor compression system. Since the acceptor and rejector are in close proximity to each other and are not easily configured to suit a refrigerator, it is necessary to introduce a secondary heat transport loop as shown in Figure 4 (a) and (b). In Figure 4 (b) the rejector is finned and a fan is used to remove the heat by forced convection. The heat transport loop is likely to be a heat pipe or reflux boiler. That is, a system in which a sealed fluid would be able to evaporate off one surface and condense on another and in so doing, transport the required heat. The sizing of the secondary heat transport loop has not been done, but a reasonable guess at the temperature differential has been provided by a heat pipe manufacturer of about 4 to 6°C. Therefore, using 6°C as an additional penalty on the heat exchangers, the source and sink temperatures chosen for the refrigerator have been set at -26°C and 41°C. Figures 5 and 6 give the Coefficient of Performance (COP) and lift for the cooler section as a function of piston amplitude. The COP is the ratio of lift to power at the piston face.

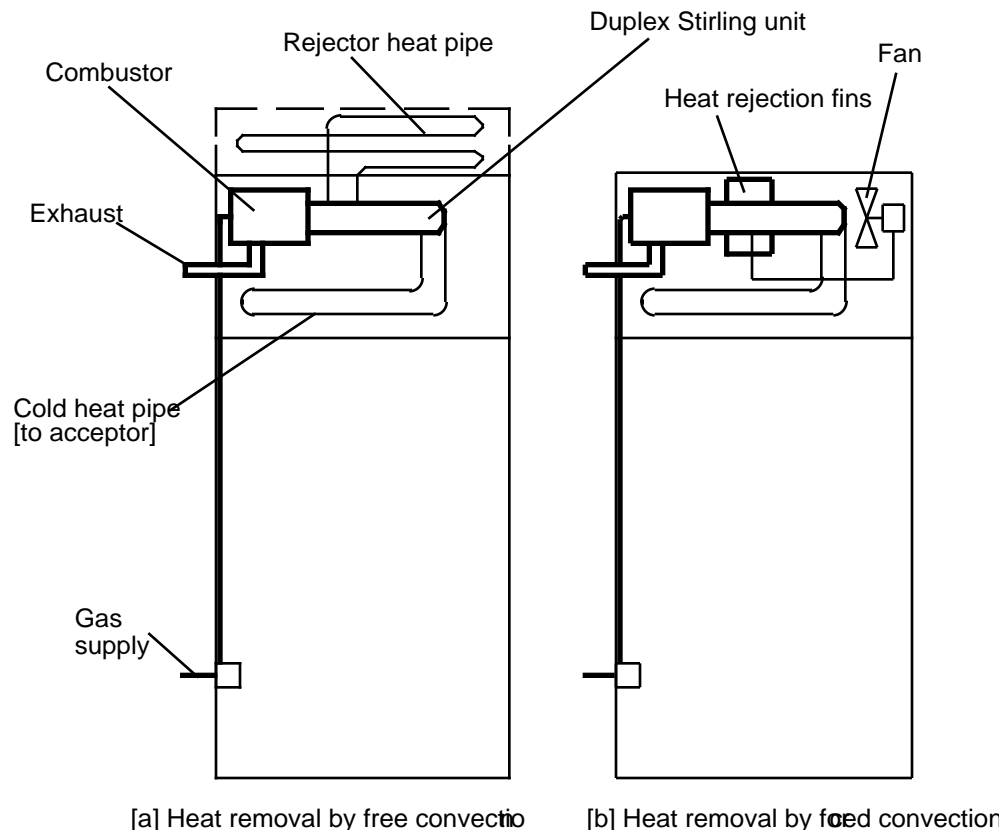

Figure 4 – Installation possibilities (not to scale)

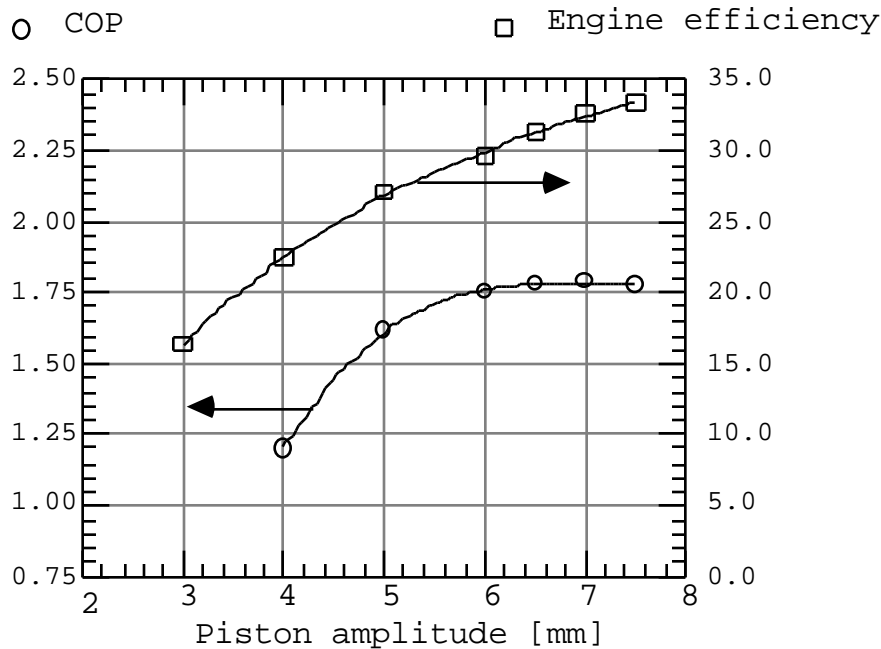

Figure 5 – COP and engine Efficiency versus piston amplitude.

A linearized analysis code¹ which has been calibrated against a number of free-piston Stirling machines was used to calculate a suitable engine. The engine has been optimized for efficiency within the constraints of a reasonable production cost. Figure 5 shows the variation of engine efficiency with piston amplitude. Ancillary electrical power may be generated from a small linear alternator placed on the common piston. In this case, electrical power of about 50W would be available. When electrical power is not required, the engine power is reduced by modulating the burner heat output. In general, the heat lift would be controlled by modulating the burner output and piston stroke while at the same time maintaining the burner temperature. Stability of the system is maintained by the linear motor, but this would require very small amounts of power. This appears to offer a good combination of control and overall efficiency. The machine is therefore expected to run almost continuously and in order to do so effectively, part load efficiencies should be high. For lower lift requirements, for example when the refrigerator door is not opened for extended periods, it may be preferable for the machine to switch off altogether.

The burner would be a high efficiency self aspirating recuperative system. This implies low temperature exhaust and low emissions. Laboratory tests on similarly sized burners using propane have yielded efficiencies of over 90% (the burner used for the demonstrator in Figure 2 was able to obtain these high efficiencies). For the purposes of this exercise, the burner efficiency is taken to be a constant 90%. Overall efficiencies are thus calculated from the known heat pump (cooler) performance, the simulated engine performance and the estimated burner performance. For comparison to vapor compression systems it is assumed that the electrical generation is nil. Figure 7 gives an impression of the overall size of the unit.

¹The linear analysis code, referred to as SAUCE (Stirling Analysis Utility Computer Emulation), is proprietary to Sunpower Inc.

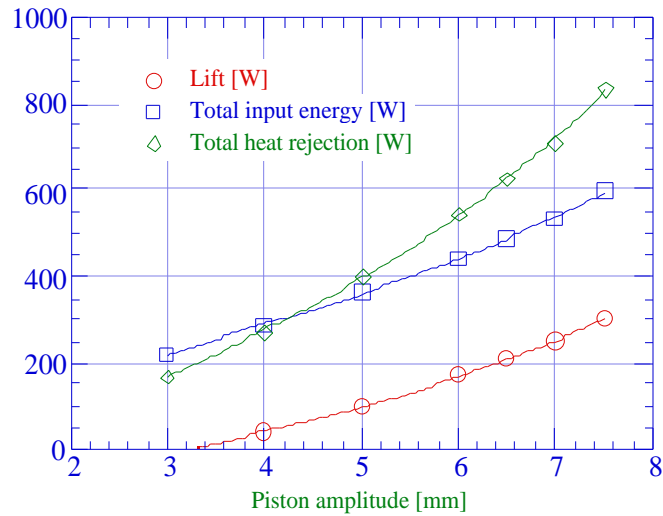

Figure 6 – Lift, total input and total rejected heat versus piston amplitude. Electrical output not shown.

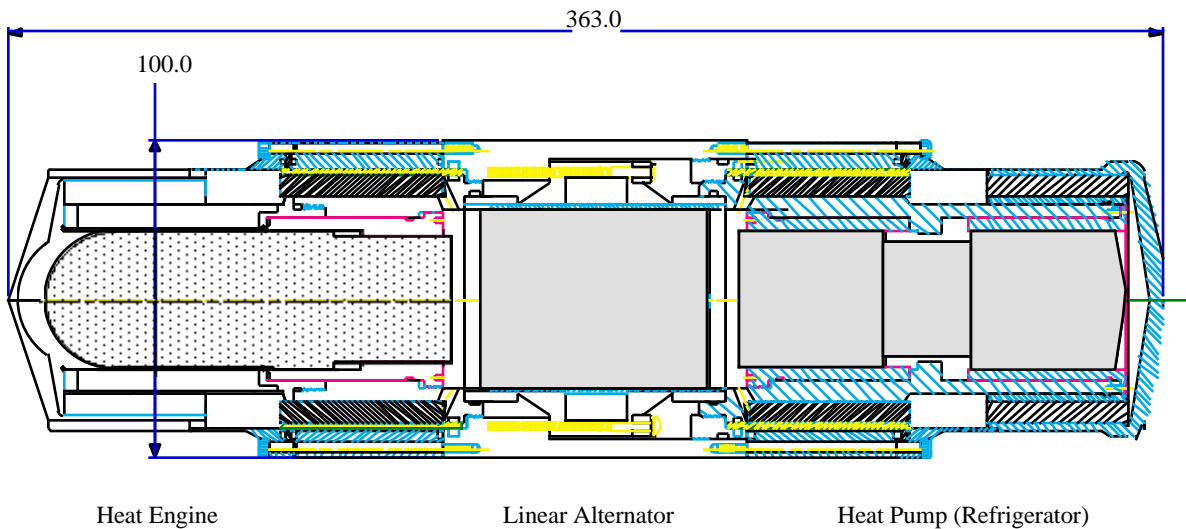

Figure 7 – Configuration and overall size of Duplex Stirling (combustor not shown)

Life and reliability are stringent requirements for this type of application. It is assumed that the non-contact gas bearings would avoid wear and the use of lower hot end temperatures for the engine will reduce creep to acceptable levels. Failure modes associated with the combustor are less well known at this point but the reliability of high efficiency domestic heating systems would tend to suggest that this need not be a problem. Since the fuel is combusted in a low pressure shrouded external combustor and the mechanical unit operates with very low levels of noise, the overall noise levels on the demonstrator units have been qualitatively similar to or less than a typical refrigerator unit.

4. PERFORMANCE AND ESTIMATED OPERATIONAL COST SAVINGS

Figure 5 and 6 give the expected overall performance of this machine when lifting from -26°C to 41°C. The design lift is 250W which is achieved at 7mm piston amplitude. Note that both the COP and engine efficiency remain fairly high over a wide range of lift. The high heat rejection of almost 800W at full lift also offers the possibility of helping with the heat requirements of the residence. A good vapor compression system for domestic refrigeration runs at about 39% Carnot for the same temperature conditions (Tecumseh AE1390 compressor system [10]). If central power generation is taken at 30% efficiency at point of use, then from a total energy standpoint, the lift to input for vapor compression is around 0.431. For the Duplex, the same ratio is likely to be 0.467 with the added possibility of utilizing the heat rejection in a cogeneration type system. It is likely that the lift to total energy input will improve for vapor compression as improvements are made in component efficiencies. Similar improvements are, of course, also available to the Duplex. Table I lists some operating costs for the Duplex and the Tecumseh vapor compression system. Both systems are assumed to be running continuously and lifting 250W. Based on these numbers, the Duplex refrigerator would have operating costs of between 39 and 54% of the vapor compression system which is a very substantial savings. Continuous modulation is likely to give further advantage to the Duplex since the on/off cycle losses associated with the vapor compression system is an additional burden. Figure 8 shows the same results as Table I in graphical format.

TABLE I

Operating costs based on energy costs in various locations in the U.S. [1]

GEOGRAPHICAL REGION	FUEL COST (\$/kilowatt hour)		OPERATING COST (¢/hour)	
	ELECTRICITY	NATURAL GAS †	TECUMSEH AE 1390 209 Watts	DUPLEX STIRLING ††
INPUT POWER AT LIFT = 250 watts:				
New England	0.100	0.024	2.10	1.05
Middle Atlantic	0.117	0.022	2.45	0.96
East North Central	0.090	0.017	1.89	0.75
West North Central	0.080	0.016	1.67	0.68
South Atlantic	0.088	0.021	1.84	0.92
East South Central	0.074	0.017	1.55	0.74
West South Central	0.083	0.018	1.73	0.76
Mountain	0.084	0.017	1.76	0.73
Pacific Contiguous	0.069	0.018	1.43	0.79
Pacific Non-Contiguous	0.103	0.014	2.15	0.61
US AVERAGE	0.089	0.018	1.86	0.79

† Based on Average Heating Value of Natural Gas for the Particular Region

†† Input Power is the Energy Required by Combustor

It should be pointed out that the engine simulated in this work was purposely chosen at an intermediate technology level. The overall size and mass is not much different to a vapor compression system, and there do not appear to be any significant cost issues. A production cost analysis has not been done, but an in-house preliminary costing on a similar technology (an electrically driven free-piston Stirling refrigerator cooler) would suggest that production costs for the Duplex could be comparable to vapor compression systems. Free-piston Stirling engines and heat pumps are capable of higher efficiencies, exceeding 40% for the engine and

50% Carnot for the heat pump. Manufacturing costs, however, are likely to increase with higher efficiencies.

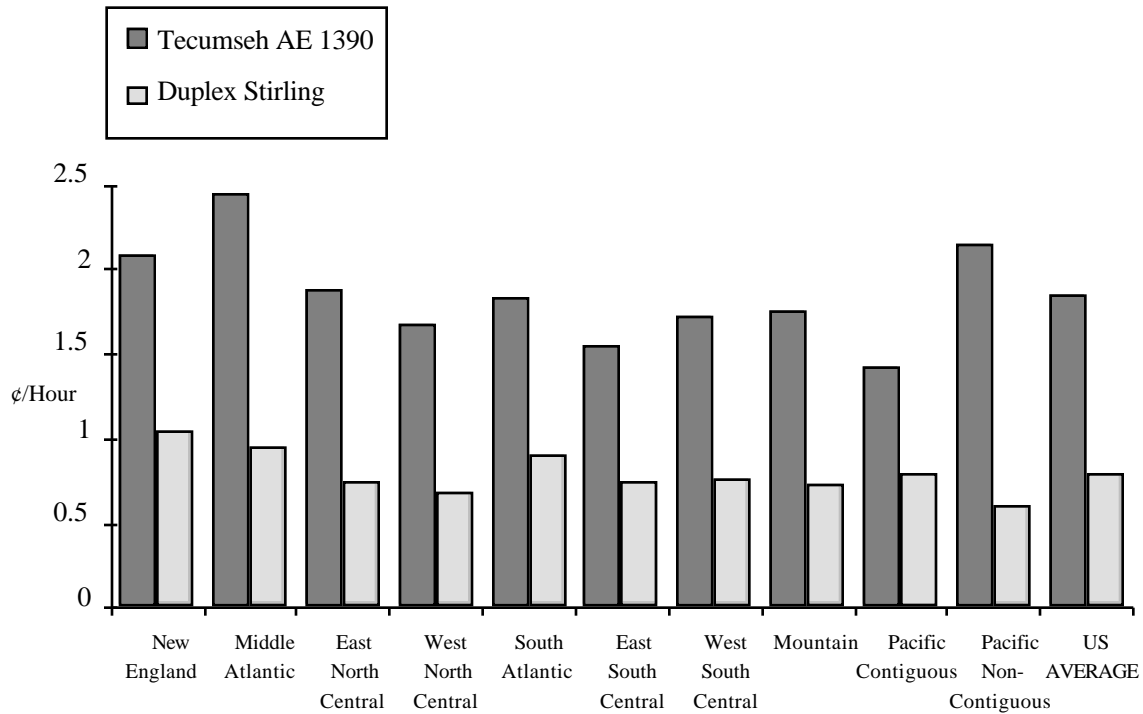

Figure 8. Relative operating costs [1]

5. MARKETING CONCERNS

Although a marketing study of the Duplex concept is beyond the scope of this paper, it is recognized that consumer acceptance of a natural gas-burning refrigerator appliance remains an open question. While absorption-cycle refrigerators, which also burn gas, were widely used in the past (and are still used in certain special applications), the Duplex Stirling machine will likely require wall penetration for venting of exhaust. This may make installation a little more inconvenient.

On the other hand, aside from operating cost savings and the environmental benefits of using helium as the working gas, there may be other marketing benefits for a Duplex Stirling. For example, the appliance could be designed to maintain operation during electrical power failures, which would eliminate food spoilage. Furthermore, the rejected heat from the cycle could conceivably be used to heat water for a dishwasher or supplement the hot water requirements of the home.

6. CONCLUSIONS

It has been shown that the Duplex Stirling arrangement, which uses no CFC's and burns natural gas as a fuel, is likely to have a low operating cost when compared to vapor compression units of similar capacity. Furthermore, the machine is able to modulate its lift according to demand, operate quietly and reliably and be of long life.

REFERENCES

1. Fabien M.J. and Berchowitz D.M. "Stirling Refrigeration Cycle Development Phase I: Scoping Study and Feasibility Analysis of the Free-Piston Stirling Cooler", ORNL/CON - In Process of Being Published - Number To Be Determined, © 1991.
2. Beale W.T. "Free Piston Stirling Engines - Some Model Tests and Simulations", SAE Cong, Detroit, MI, Jan 13-17, 1969. Also SAE paper 690230.
3. Penswick B. and Urieli I. "Duplex Stirling Machines", *Proc 19th IECEC*, San Francisco, 1984.
4. Redlich R.W. and Berchowitz D.M. "Linear Dynamics of Free-Piston Stirling Engines", *Proc Instn Mech Engrs*, Vol 199, No A3, March 1985, pp 203-213.
5. Godin M. *Étude d'un Moteur Stirling à Pistons Libres en vue de son Application à l'Énergie Solaire*, Doctor of Engineering Thesis, l'Universite Paris-Val-De-Marne, Paris 12, France, Oct 1978.
6. Berchowitz D.M. *Stirling Cycle Engine Design and Optimisation*, PhD Thesis, University of the Witwatersrand, Johannesburg, South Africa, August 1986.
7. Berchowitz D.M. and Unger R. "Experimental Performance of a Free-Piston Stirling Cycle Cooler for Non-CFC Domestic Refrigeration Applications", XVIII th International Congress of Refrigeration Inc., Montréal, Canada, August 1991.
8. Energy Information Administration/Office of Coal, Nuclear, Electric and Alternate Fuels; Typical Electric Bills Based on January 1, 1988 Rates; DOE/EIA-0040(88), U.S. Department of Energy, Washington, D.C., ©1988.
9. Energy Information Administration/Office of Oil and Gas; Natural Gas Annual 1989; DOE/EIA-0131(89), U.S. Department of Energy, Washington, D.C., ©1990.
10. Sand J.R. Unpublished data, Oak Ridge National Laboratory, Tennessee, 1991.

ESTIMATION DU CALIBRAGE ET DE LA PERFORMANCE D'UN STIRLING DUPLEX ALIMENTÉ AU GAZ NATUREL POUR DES APPLICATIONS DOMESTIQUES DE RÉFRIGÉRATION

RÉSUMÉ: Des calculations étalonnées sont utilisées afin d'optimiser et de calibrer une unité Stirling intégrée réfrigération/moteur (appelée configuration Duplex) pour des applications domestiques de préservation des denrées alimentaires. Le gaz naturel est la source d'énergie pour ce moteur. Les questions concernant la durabilité, le bruit et la performance sont adressées en référence au matériel existant. Par exemple, les niveaux de bruit sont extrêmement bas vu que le gaz entre en combustion extérieurement dans un brûleur blindé; de plus le taux des vibrations sont plus bas que chez les compresseurs de réfrigérateurs traditionnels. La chaleur des gaz d'échappement est récupérée; elle est donc à basse température lorsqu'elle sort de l'appareil. Une comparaison des coûts de fonctionnement est effectuée entre des réfrigérateurs électriques traditionnels et le procédé Stirling Duplex au gaz naturel. Une production d'énergie électrique est aussi possible en introduisant un petit alternateur linéaire. Celui-ci peut alimenter la lumière interne et d'autres accessoires. Des modèles à démonstration ont été construits et mis à l'essai.

AN EXPERIMENTAL STUDY ON THE REFRIGERATION CAPACITY AND THERMAL PERFORMANCE OF FREE PISTON STIRLING COOLERS

Emre Oguz, Fatih Ozkadi
Arcelik A.S.
Research & Development Center
81719, Tuzla, Istanbul TURKEY

ABSTRACT

The refrigeration capacity and thermal performance characteristics of two prototype free piston Stirling coolers were investigated experimentally. Thermal load was applied to the cold head of the Stirling cooler by two resistance heaters in a so-called adiabatic box, and steady-state characteristics of the coolers were evaluated. For a certain input voltage, different tests were carried out to determine the variation of the performance with the cold head temperature, hence the cold head temperature of the coolers varied from -40°C to 0°C . Since the refrigeration capacity of a free piston Stirling cooler changes with the applied voltage, tests were repeated for three different input voltages for one of the coolers. The capacity data were simply correlated in terms of the cold head temperature to predict the change of the refrigeration capacity with the applied voltage for constant warm and cold head temperatures.

INTRODUCTION

Since the novel invention of Robert Stirling in 1816, the Stirling cycle machines have always been of great importance for the researchers and engineers to generate electrical or mechanical power more efficiently or to reduce the energy consumption of the refrigeration devices. The commercial Stirling cycle coolers have been used in cryogenic applications since 1940s but it has not been possible yet to utilise the cycle for domestic refrigeration applications. However, with the invention of the free piston technology in the early 1960s by William Beale [1], the Stirling cycle now seems to be a challenging alternative for domestic refrigeration.

Theoretical Stirling cycle consists of two isothermal and two isovolumetric heat transfer processes where the isovolumetric heat transfer takes place in a regenerative manner. While rejecting thermal energy to the environment during the isothermal compression process, the gas absorbs thermal energy from the environment during the isothermal expansion. Therefore, a Stirling cycle cooler may be determined by a high and a low temperature which are generally named warm and cold head temperatures. Extensive literature exists both on the

thermodynamics and gas dynamics of Stirling cycle and the performance analysis of Stirling cycle machines [2, 3, 4].

A detailed study on the refrigeration capacity and thermal performance of free piston Stirling coolers was presented by Mc Donald et al. [5]. The Stirling coolers had been designed for a particular application to cool an insulated volume of 0.3 m³ and a thermal lift of 124 W at 23°C and 4°C ambient and cabinet temperatures respectively. The performance map presented, covers the refrigeration capacity and input power data of the cooler for a cold head temperature range of -10°C to -90°C and a piston amplitude range of 4.5 to 6.5 mm where the warm head temperature had been assumed to be constant at 45°C.

An interesting study on the free piston coolers and Stirling cycle cooled domestic refrigerators was presented by Berchowitz [6]. The coefficient of performance values of a prototype Stirling cooler for three different thermal lifts, namely 20, 40 and 70 W were given and the COP value was reported to be approximately 3.0 for 0°C cold and 30°C warm head temperatures. Additional information on the energy consumption predictions of domestic refrigerators which uses advanced insulation technologies like Vacuum Insulation Panels or Vacuum Insulation Components and operating with a free piston Stirling cooler, may be found in this study.

In a recent study by Berchowitz et alia, the construction and test results of a Stirling cycle cooled portable cool box are given in detail [7]. A 40 W capacity free piston cooler had been used to cool a 40 liter cabinet, providing the thermal energy exchange by a system called thermosyphon employing carbondioxide as the heat transfer media. Presented experimental results are stated to be much better than Peltier or small vapour compression systems.

Another study including thermosyphon installation as the heat transfer system was presented by Green et al. [8]. A Stirling cycle cooler built by Oxford University had been integrated into a freezer cabinet and the layout of the cabinet had been modified accordingly. The fluids used in the thermosyphon system were water and isobutane for the warm and cold circuits respectively. Although the energy consumption of the Stirling cycle cooled freezer is reported to be 17% less than the original equipment, the authors state that the Stirling cycle freezer would consume 12% less energy than the mechanical compression system on a like for like basis.

EXPERIMENTAL SETUP AND PROCEDURE

Free Piston Stirling Coolers

Free piston Stirling coolers used in the current study are the first model prototypes of Global Cooling. The cooler may be defined as a pressure vessel which operates by shuttling

approximately 1 gram of Helium back and forth by the combined movements of two parts, namely the piston and the displacer. While the piston that compresses the gas is driven by a linear motor, the displacer is moved by the pressure difference.

Since the surfaces enclosing the compression and expansion spaces are relatively small and the temperature differential between the gas and the heat sink / source must be as small as possible to obtain higher COP values, additional heat exchangers are supplied on the cold and warm heads of the cooler. Hence, it is possible to circulate a secondary media such as water to increase the heat transfer effectiveness. The Stirling coolers used in this study are 50 Hz AC units. Since the piston amplitude is directly proportional to the RMS of the drive voltage, the refrigeration capacity of the coolers may easily be adjusted for different heat loads.

Test Rig

A schematic diagram of the so-called adiabatic box and the position of the free piston Stirling cooler is given in Figure 1. The cold surface of the cooler is enclosed in a box which was insulated to prevent heat-leak / heatgain to or from the environment. Conventional XPS (Extruded Polystyrene) with a thermal conductivity of 28 mW/m.K was used as the inner layer of insulation. At the outer layer, vacuum insulation panels with a thermal conductivity of 6 mW/m.K were placed to minimise the heat transfer. It was theoretically calculated that the vacuum insulation panels (VIPs) had decreased the heat transfer rate approximately 70% for the same operating conditions. A plastic layer was used to protect the VIPs from possible damages and finally the insulation was covered with a metal case. Two cylindrical resistance heaters were placed on a copper disc and the disc was mounted on the cold surface of the Stirling cooler. The heaters used were rated 100 W at 220 V and controlled by variacs.

For the warm side of the Stirling cooler, a hydraulic circuit was provided. Water was pumped from a reservoir first through the heat exchanger on the cooler to cool the warm end of the cooler and then through another heat exchanger to reject thermal energy to the ambient. The second heat exchanger was provided with a fan to increase the heat transfer rate from the water to the ambient air. A valve was also provided to control the flow of water.

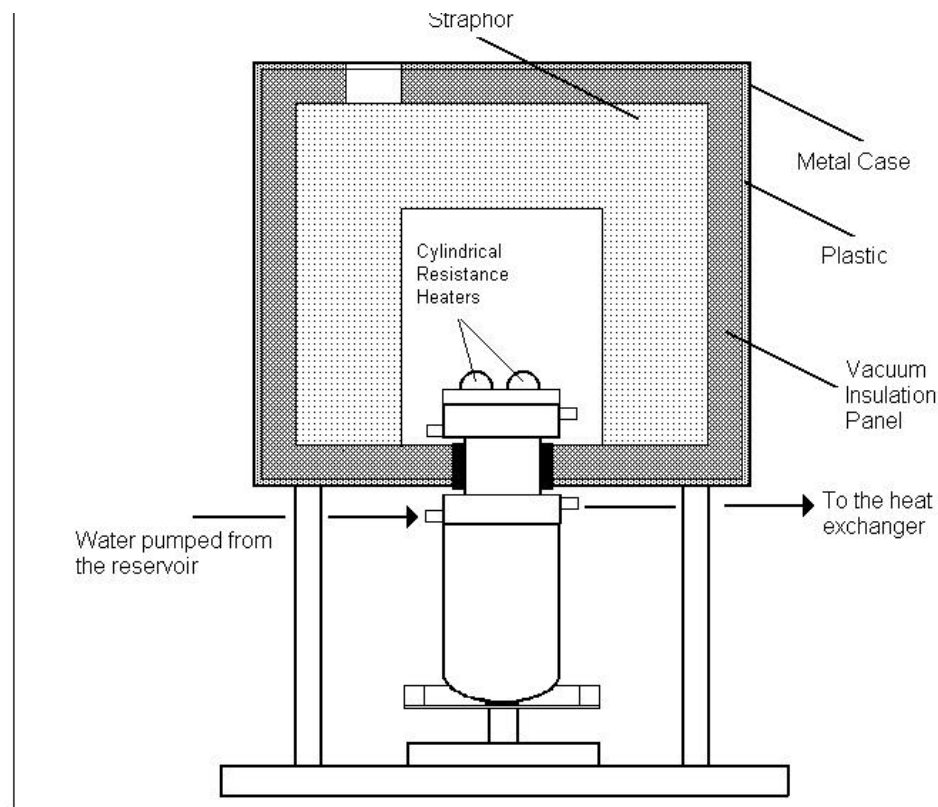

Figure 1. Schematic diagram of the so-called adiabatic box and the FPSC.

Instrumentation and Experimental Procedure

The parameters measured during the tests were the cold and warm head temperatures of the Stirling cooler, the temperatures of the ambient air and the air inside the adiabatic enclosure, the temperatures of the inner and outer surfaces of the so-called adiabatic box. For the temperature measurements type T thermocouples and a data logger were used with an accuracy of $\pm 0.3^{\circ}\text{C}$. Electrical parameters measured during the experiments were the voltage input, current and the power consumption of the cooler and the power consumptions of the resistance heaters. The wattmeter used had an accuracy of $\pm 0.1\%$, $\pm 0.2\%$ and $\pm 1\%$ for voltage, current and power readings respectively. Uninterruptable power supply was used for all of the tests.

Three thermocouples were placed at the inner surfaces and six thermocouples were placed at the outer surfaces of the enclosure to predict the heat transfer rate theoretically. The maximum rate of heat transfer was predicted to be 2.5 W without the vacuum insulation panels. After the VIPs had been placed to enhance the effectiveness of the insulation, the heat transfer for the same operating conditions was predicted to be less than 1.5 W.

At the beginning of all of the tests, the voltage input of the cooler being tested and the thermal load applied by the heaters were adjusted to certain levels. Since it would take more

time to reach steady-state at certain cold head temperatures, the thermal load was chosen as the independent parameter. After a certain time interval the system was observed to reach steady-state and the coolers were run for approximately one more hour at steady-state. Cooldown and steady-state periods of a typical test are given in Figure 2. For clarity, the temperatures of the outer and inner surfaces are not given here.

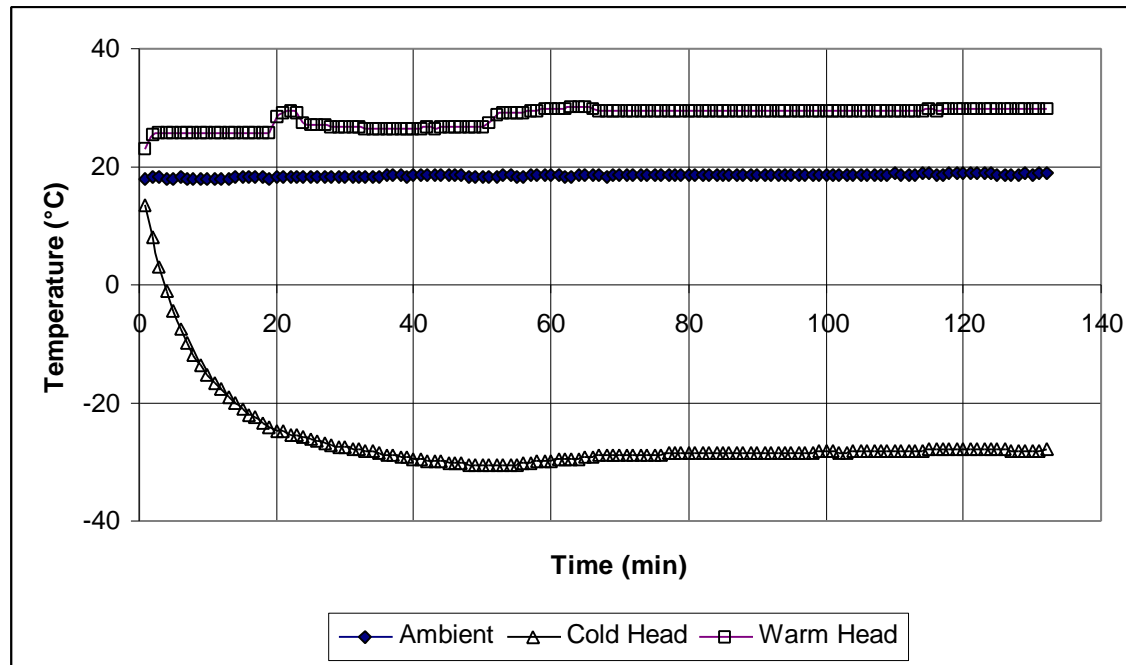

Figure 2. Cooldown and steady-state periods of a typical test.

After a test was completed, the steady-state interval was determined using the fluctuations in the temperatures recorded, and the average values of measurement parameters were calculated in the same interval. Except two of the 15 tests conducted on two different Stirling coolers, the variation of the cold head temperature during the specified steady-state intervals was well within $\pm 0.5^\circ\text{C}$, during the two tests the variation reaching $\pm 0.8^\circ\text{C}$. The specified steady-state periods vary between 40 to 110 minutes, most of the periods lasting for more than an hour.

Since a simple calorimetric method is used, for a certain input voltage and cold and warm head temperatures, the refrigeration capacity of the cooler may be determined from the steady-state form of the first law of thermodynamics applied to the control mass in the adiabatic enclosure, which may be written as follows

$$\dot{Q}_{\text{load}} - \dot{Q}_{\text{cap}} - \dot{Q}_{\text{leak}} = 0 \quad (1)$$

where subscripts load, cap and leak refer to the thermal load applied by the heaters, the refrigeration capacity of the cooler and the heat leak to the environment respectively. Accordingly, the coefficient of performance of the cooler may be calculated as

$$\text{COP} = \frac{\dot{Q}_{\text{load}} - \dot{Q}_{\text{leak}}}{\dot{W}_{\text{cooler}}} \quad (2)$$

where \dot{W}_{cooler} represents the power consumption of the cooler.

TEST RESULTS

The refrigeration capacity of the two coolers tested are given in Figure 3. Cooler #1 was tested for 100, 110 and 120 V and cooler #2 was tested for approximately 80 V. Since all of the data points are plotted on the same graphic, a common warm head temperature must be stated for the chart to be meaningful. However, the warm head temperature during different tests varied between 28 to 31°C and hence, the common warm head temperature may be declared as 30°C.

Referring to Figure 3, it must be stated that curve fitting was not applied to the data of cooler #2 for clarity. It is easily seen that for constant warm head temperature and input voltage the refrigeration capacity may easily be represented as a linear function of the cold head temperature. Evaluating this feature, linear functions are obtained for cooler #1 and the change of the refrigeration capacity with the input voltage for constant cold head temperatures is presented in Figure 4.

Referring to Figure 4, it must be remembered that only the data between 100 and 120 V are experimental and could be represented in a linear fashion. Therefore, considering the refrigeration capacities at input voltages higher than 140 V, one may expect high discrepancies because of the complicated processes that occur in a free piston Stirling cooler.

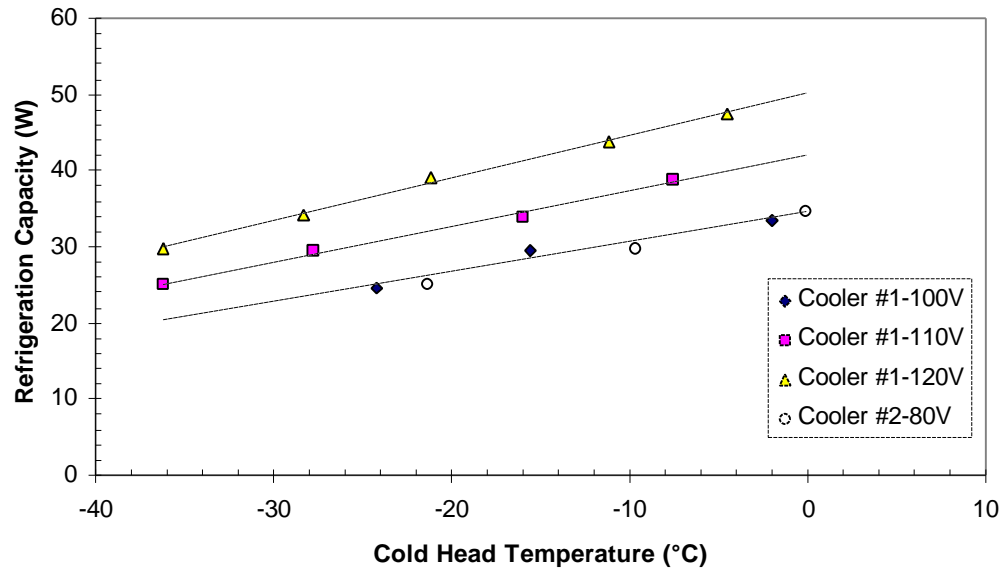

Figure 3. Refrigeration capacity of coolers #1 and #2 (Warm head temperature:30°C)

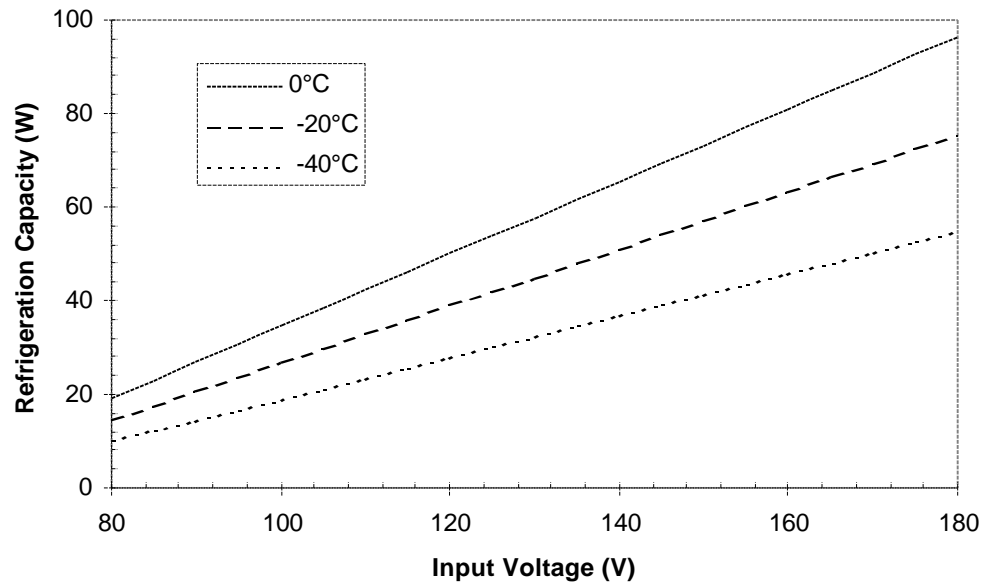

Figure 4. Refrigeration capacity (predicted) as a function of input voltage (Cooler #1).

The coefficient of performance values for both of the coolers are presented in Figure 5. There seems to be some discrepancy as high as 25% between the coolers. This difference is thought to be caused by the thermocouple soldering process at the very beginning of the experiments which could overheat the internal components of the cooler #1. On the other hand, COP values of 2.2 or more could be reached with this cooler with a cold head temperature of -2°C and a warm head temperature of 30°C .

In Figure 6, the temperature-independent COP values are presented as the fraction of the Carnot COP. Referring to Figure 6, it must be noted that the Carnot COP values are based on the cold and warm head temperatures.

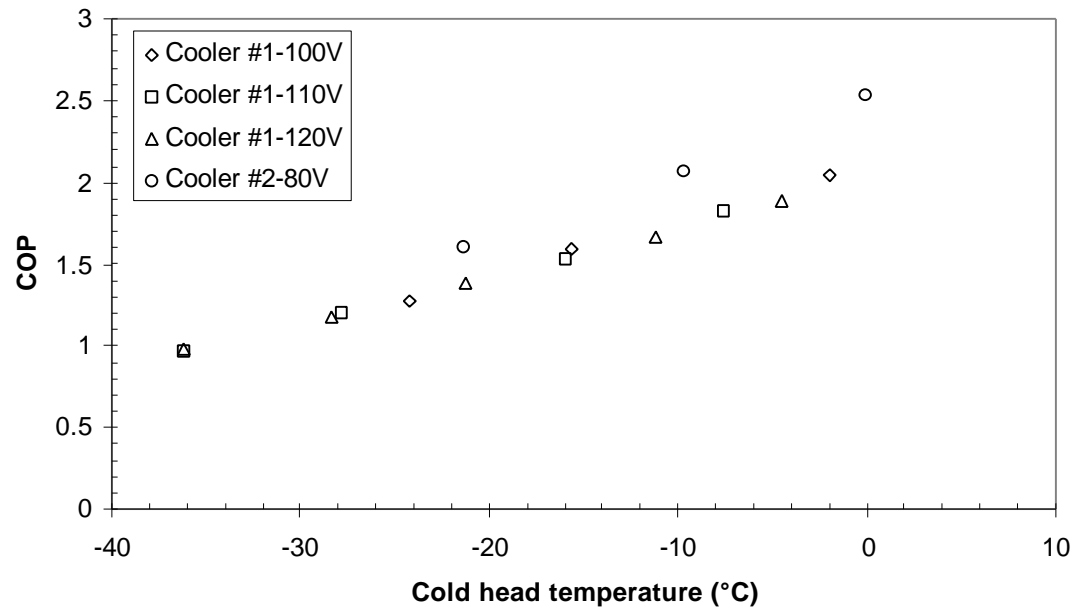

Figure 5. COP values for coolers #1 and #2 (Warm head temperature: 30°C)

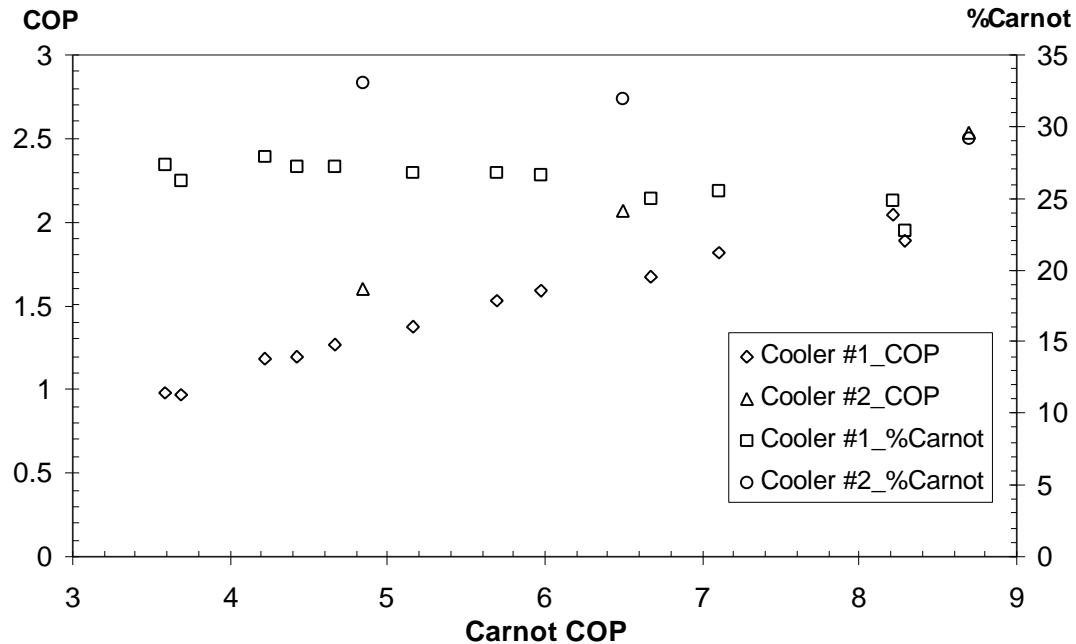

Figure 6. COP and Carnot Fraction for coolers #1 and #2.

CONCLUSION

A method for measuring the refrigeration capacities and thermal performances of free piston Stirling coolers is described and the test results for two different coolers are presented. According to the results of the current study, it may be concluded that :

- For a warm head temperature of 30°C, the refrigeration capacities of free piston Stirling coolers tested may be modulated from 10 to 100W by simply varying the input voltage. Therefore, it can be concluded that Stirling coolers operate in a similar manner to the variable capacity compressors (VCCs).
- For 0°C / 30°C cold and warm head temperatures and an input voltage of approximately 80V, COP value of 2.5 is measured for the cooler. This result has been encouraging to integrate the coolers to refrigerators (fully freshfood compartment).
- Free piston Stirling technology is a challenging alternative to be used instead of conventional compressors and the experimental and theoretical studies on this subject should continue in the future.

ACKNOWLEDGEMENTS

The authors would like to thank to Mr. Refik Üreyen, Technology Coordinator in Arcelik A.S, Mr. Sefik Senyürek, director of the Research & Development Center, Mr. Yalçın Tanes, research manager of the mechanical technologies group in the R&D Center and to Prof.Dr. Nilüfer Egrican, the Dean of the Mechanical Engineering Faculty, Istanbul Technical University, for their endless encouragement.

REFERENCES

- [1] Urieli, I., Berchowitz, D.M., *Stirling Cycle Engine Analysis*, 1st Edition, Adam Hilger Ltd., 1984.
- [2] Organ, A.J., *The Thermodynamics and Gas Dynamics of the Stirling Cycle Machine*, 1st Edition, Cambridge University Press, 1992.
- [3] Lundqvist, P.G., *Stirling Cycle Heat Pumps and Refrigerators*, Doctoral Thesis, The Royal Institute of Technology, Stockholm, Sweden, 1993.
- [4] Chen, J., Yan, Z., *The General Performance Characteristics of a Stirling Refrigerator with Regenerative Losses*, J. of Physics D:Appl. Physics, **31**, 291-293, 1996.
- [5] McDonald, K., Berchowitz, D.M., Rosenfeld, J., Lindemuth, J., *Stirling Refrigerator for Space Shuttle Experiments*, 29th IECEC, Monterey, CA, 1994.
- [6] Berchowitz, D.M., *Stirling Coolers for Solar Refrigerators*, International Appliance Technical Conference, West Lafayette, US, 1996.
- [7] Berchowitz, D.M., McEntee, J., Welty, S., *Design and Testing of a 40 W Free-Piston Stirling Cycle Cooling Unit*, 20th International Congress of Refrigeration, Sydney, AU, 1999.
- [8] Green, R.H., Bailey, P.B., Roberts L., Davey, G., *The Design and Testing of a Stirling Cycle Domestic Freezer*, 2nd Int. Conf. on the Use of Non-Artificial Substances, Aarhus, Denmark, 1996.

MINIATURE STIRLING COOLERS

D. M. Berchowitz

MINIATURE STIRLING COOLERS

D.M.Berchowitz

Chief Engineer

Sunpower, Inc

Athens, Ohio

ABSTRACT

Free-piston Stirling cycle coolers appear to offer the best opportunities for compact cooling where high specific capacities (lift/mass) are required. Furthermore, they are quiet, efficient, have low vibration and recent developments suggest that very long life may be expected. These characteristics are vital when considering active cooling (refrigeration) for electronic components. Comparisons are made to Rankine (vapor compression) and thermoelectric cooling. Free-piston Stirlings have only recently been seriously considered for electronic cooling and studies suggest that much is possible in terms of miniaturization. However, there are fundamental limits imposed by thermodynamics that restrict miniaturization no matter how close the cooling machine comes to operating without losses.

INTRODUCTION

As miniaturization of electronics continues, the problems of heat removal become more difficult. In addition, many electronic systems perform better (or only) at subambient or cryogenic temperatures. For all these applications, the basic performance requirements include lift (heat transferred at cold end, also referred to as capacity), temperature of the cold end, and input power. As temperatures go lower, input increases for the same lift. This is a consequence of the laws of thermodynamics and is true irrespective of the means to achieve cooling. However, there is a minimum power level for a given cold temperature and lift. This minimum power is dictated by the Carnot efficiency, which cannot be exceeded. For coolers and refrigerators the efficiency is generally represented in terms of the coefficient of performance (COP) as a fraction of the maximum possible COP (the Carnot COP).

$$\text{COP} = \frac{\text{Heat lift [W]}}{\text{Power input [W]}} \quad (1)$$

Thus the fraction of ideal performance would be given by:

$$\eta = \frac{\text{COP}}{\text{COP}_{\text{Carnot}}} \quad (2)$$

where the $\text{COP}_{\text{Carnot}}$ is a function only of the absolute temperatures of the source and sink, namely:

MINIATURE STIRLING COOLERS

D. M. Berchowitz

$$\text{COP}_{\text{Carnot}} = \frac{T_c}{T_h - T_c} \quad (3)$$

where T_c is the absolute cold temperature and T_h the absolute warm temperature.

Thus if the lift per unit of input is known for given source and sink temperatures, then the fraction of ideal performance may be determined by which measure the efficiency of different systems may be compared.

Other important factors for comparing different systems is the specific lift (lift per unit mass) and the lift per unit volume. These factors give an idea of cost and size [1].

FREE-PISTON STIRLING CYCLE

The Stirling cycle alternately compresses a fixed mass of gas (usually helium) at one temperature level and expands it at another in a closed regenerative cycle in order to either lift heat or do work. The thermodynamic cycle is covered in more detail elsewhere [1, 2]. Suffice it to say here that in its ideal form, the Stirling cycle has the highest possible efficiency for any thermodynamic cycle.

Originally Stirling machines were all driven kinematically, that is, by way of crank shafts and connecting rods as is used in most positive displacement machinery. The kinematic configurations have led to a number of problems peculiar to the Stirling, these being the contamination of the internal heat exchangers by the lubricating oil, the difficulty in containment of the pressurized working gas and high friction in the seals due to the more severe duty required of them. The sum effect being to bar these machines from becoming long life, low cost products. In an effort to circumvent these problems, W. T. Beale suggested the free-piston configuration which is shown in Figure 1 [3]. The free-piston Stirling employs the internal gas pressures and a linear motor to move the reciprocating components in the proper fashion. In so doing, a number of benefits accrue, namely:

- i) The side loads on the moving parts are so low that it becomes practical to utilize gas bearings and therefore avoid the need for lubricating oil. Since gas bearings operate without contact, there is practically no wear or friction and long life can be expected in addition to high mechanical efficiency.
- ii) A linear motor for supplying power to the piston is easily placed within the pressure vessel making it possible to hermetically seal the unit which avoids the working gas leakage problem.
- iii) Modulating the machine becomes a simple matter of adjusting the piston stroke which for a linear motor simply means controlling the input voltage.
- iv) The motion of the moving parts are almost pure sinusoids. Thus, the higher harmonic content in the vibration of the unit is very small. This makes it easy to balance the machine with a simple dynamic absorber to levels of very low residual amplitude. A machine balanced in this manner is extremely quiet.
- v) Simplicity of construction. The basic machine has only two moving parts and no valves.

MINIATURE STIRLING COOLERS

D. M. Berchowitz

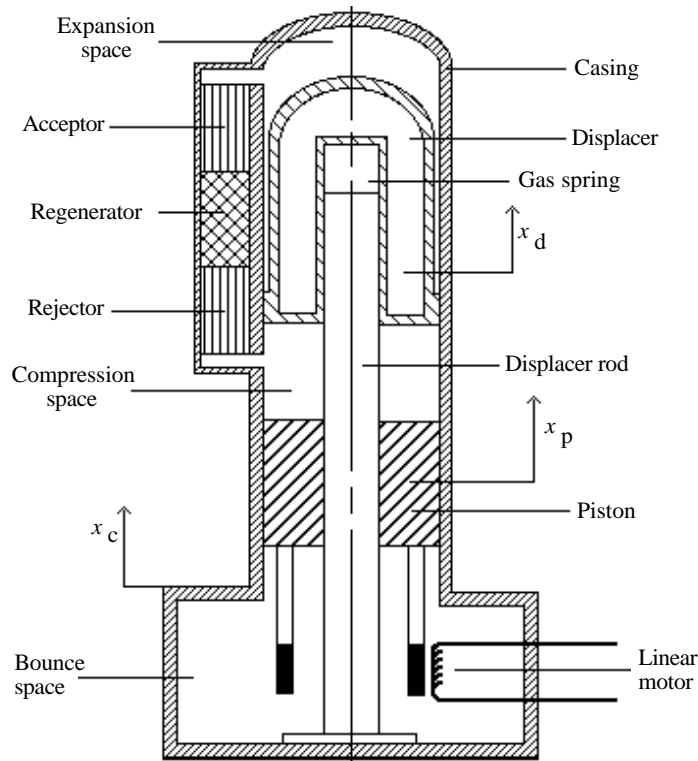

Figure 1 General arrangement of a free-piston Stirling cooler driven by a linear motor

Mechanically, therefore, the free-piston / linear motor Stirling cooler is of high overall efficiency and is able to operate reliably for extended periods of time. Its behavior may be understood by describing it as a tuned mechanical oscillator where the resonances of the displacer and piston are such so as to obtain an optimum phase angle between their motions. A full theoretical treatment along these lines is available in [4].

COMPARISON WITH THERMOELECTRIC COOLING

The attraction of thermoelectric cooling is that there are no moving parts associated with the cooling process. Unfortunately efficiencies are very poor resulting in large units drawing high powers for moderate amounts of lift. Since the heat rejected is equal to the input power plus the lift, the rejector heat exchanger often needs to be fairly large. Figure 2 shows the performance of commercially available staged thermoelectric coolers compared to two free-piston Stirling units. At temperatures of around -50°C (a ΔT of between 80° to 100°C), the Stirling is over one order of magnitude better in COP than the staged thermoelectric. Thus, a lift of 40W at 50°C to $+50^{\circ}\text{C}$ ambient requires 2kW input for the thermoelectric device while only requiring 67W for the free-piston Stirling cooler. This advantage increases dramatically as lower temperatures are approached (larger delta temperature).

MINIATURE STIRLING COOLERS

D. M. Berchowitz

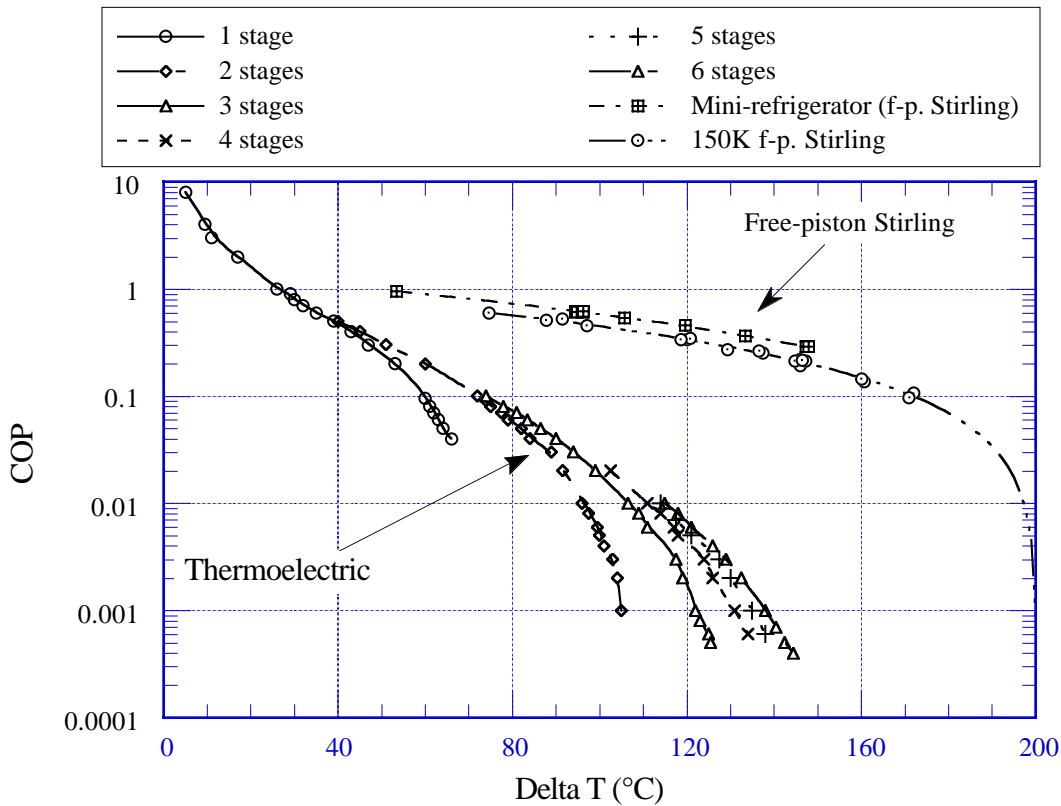

Figure 2 - Thermoelectric vs Free-Piston Stirling (Delta T = Reject temperature - Cold temperature)

COMPARISON WITH RANKINE COOLING

The Rankine (vapor compression) cycle is probably the most common means for providing cooling and is used almost exclusively for domestic refrigeration and air conditioning. This cycle tends to perform best in applications where the cold end temperature is above -30°C . For temperatures below -30°C the efficiency falls off and eventually it is necessary to cascade the cycle in order to obtain reasonable performance or even low enough temperatures. Cascading refers to the practice of using one cycle to precool the next one and so on until the desired temperature/lift combination is reached. Figure 3 compares the performance of the Rankine cycle and the free-piston Stirling in temperature ranges of several commercial applications. The curves labeled maximum Stirling are considered to be the optimum performance with known science. The term DT refers to the temperature differential necessary to transfer heat in the heat exchangers. For the sake of simplicity both the acceptor (cold) and rejector (warm) heat exchangers are assumed to have similar DT's. For warmer temperatures (higher ideal COP's) it can be seen that except for the case of extremely small DT's, the Stirling has great difficulty competing against existing Rankine units. When large heat fluxes are involved, the DT's tend to be higher thus compromising the Stirling further. However, scale has an important effect here. Smaller capacity machines tend to have lower heat fluxes owing to the area to volume ratio which increases as the size decreases. For example, a small 50W lift free-piston Stirling was compared to a similar capacity Rankine unit at domestic refrigeration temperatures (about -30°C). The efficiency of the Stirling was measured to be 15% better than the Rankine as tested in the original refrigerator cabinet. If the power to the Stirling's cooling fan, which was particularly inefficient, is neglected, then the advantage increases to 50% [5]. Furthermore, the

MINIATURE STIRLING COOLERS

D. M. Berchowicz

Stirling requires no heat rejection coil and is much smaller, lighter and operates more quietly. The free-piston Stirling thus competes with the Rankine as cold temperatures fall below about -30°C and as capacity goes down. Lower capacity tends to push the point of equivalent performance to warmer cold-end temperatures. A final point regarding the Rankine is the concern raised by the use of CFC refrigerants which have been implicated in the destruction of the earth's ozone layer. At warmer temperatures it now appears that safe refrigerants will be available. At lower temperatures, though, say below -40°C , no reliable environmentally acceptable alternatives have as yet been identified. The helium working gas of the Stirling is, of course, completely benign.

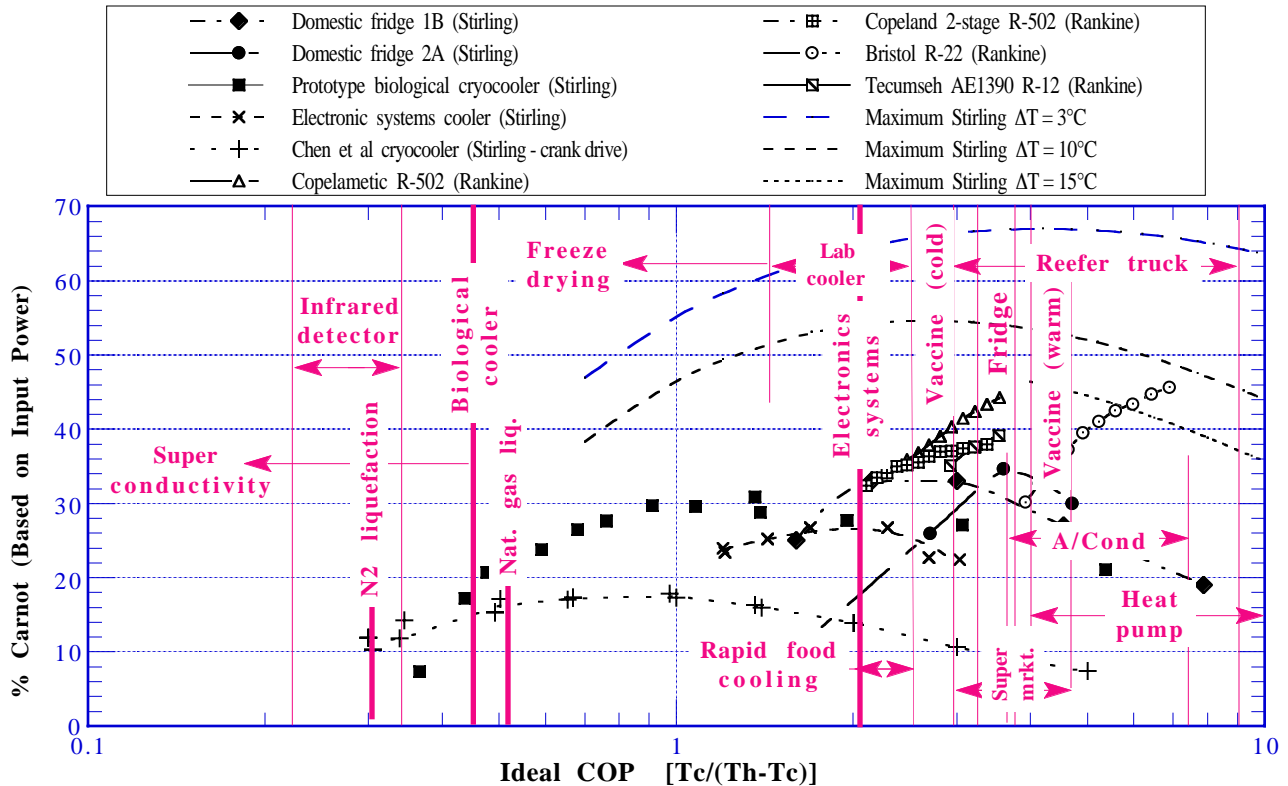

Figure 3 - General comparison of Stirling and Rankine for different applications [6]

Figure 4 shows a horizontally opposed free-piston Stirling cooler designed for use aboard the Space Shuttle where it will replace the original Rankine equipment. The horizontally opposed configuration achieves almost perfect balance without the need of a vibration absorber. The machine therefore operates with extremely low noise levels. Figure 5 shows the anticipated performance map for the unit. Modulation for the Stirling is continuous whereas for the Rankine "on-off" modulation is typically used to control temperatures. This leads to an additional overall energy usage advantage for the Stirling. Efficiencies already measured are considerably higher than the original Rankine equipment. The total mass of the opposed Stirling pair is about 5kg.

MINIATURE STIRLING COOLERS
 D. M. Berchowitz



Figure 4 - General configuration of opposed free-piston Stirling cooler (cooling fans are at each end)

Figure 4 - General configuration of opposed free-piston Stirling cooler (cooling fans are at each end)

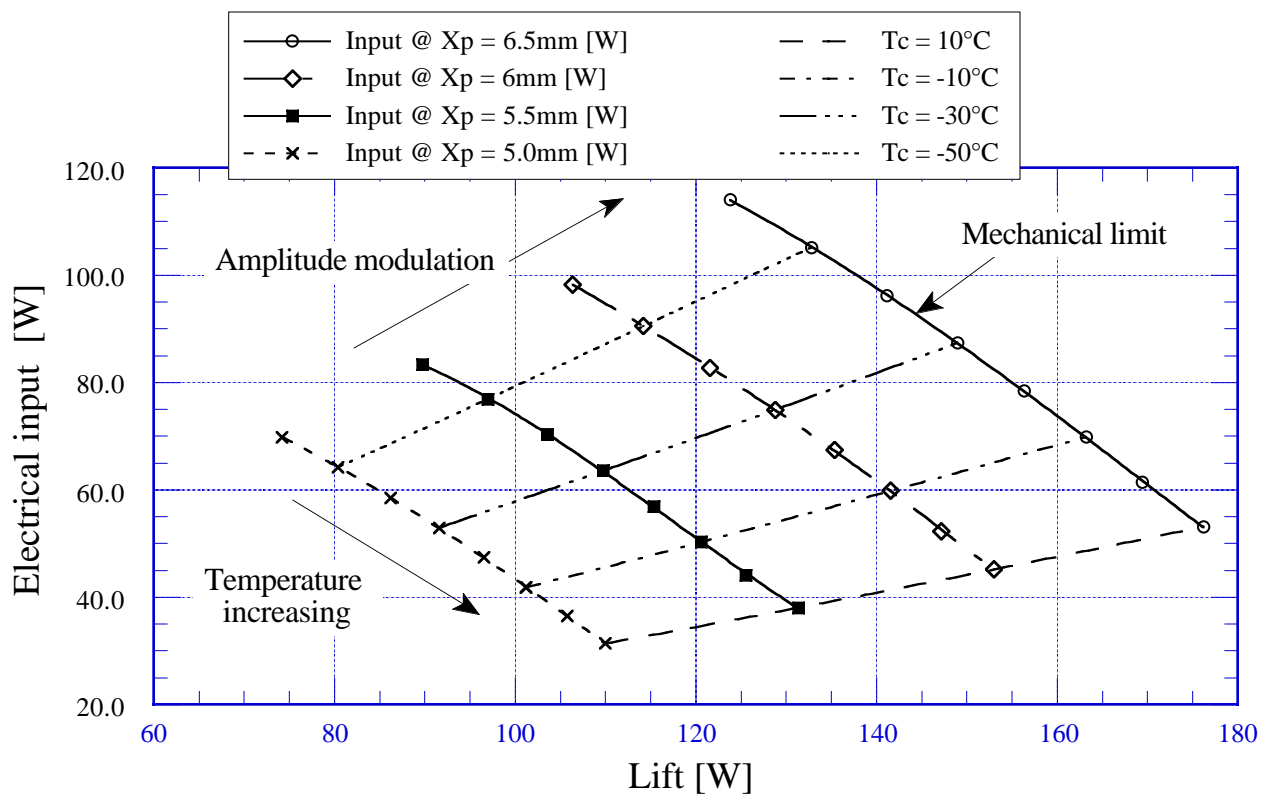

Figure 5 - Performance map for opposed free-piston Stirling cooler (input voltage controls the piston amplitude, X_p)

MINIATURE STIRLING COOLERS

D. M. Berchowitz

PERFORMANCE AND SIZE LIMITS FOR FREE-PISTON STIRLING COOLERS

The machines shown in Figures 6 and 7 are representative of the current level of development of small free-piston Stirlings. Figure 6 shows a machine that lifts 35W at -50°C and Figure 7 shows a derivative cryocooler capable of lifting 4.0W at 77K. These machines are about 2.5kg mass and 86mm square at the fan end. The 35W machine is 205mm tall and the cryocooler is 260mm tall. Power input depends on a combination of lift and temperature. The motors are capable of absorbing 90W, however, the 35W cooler runs steady state at about 65W input. The cryocooler requires only 30W to maintain 77K but takes up to 90W at 4.0W lift. Both these machines operate at 60Hz which is considered to be high for mechanical devices of this type. To the first order, size is inversely proportional to frequency. So the higher the frequency the smaller the device. Free-piston Stirlings have the advantage over crank machines in that higher operational frequencies are possible since piston side loads are not a function of piston speed. Crank machines are limited in this manner, particularly when lubrication is restricted. Size is also affected by efficiency since lower inputs for a given lift lead to smaller motors and smaller heat rejectors.

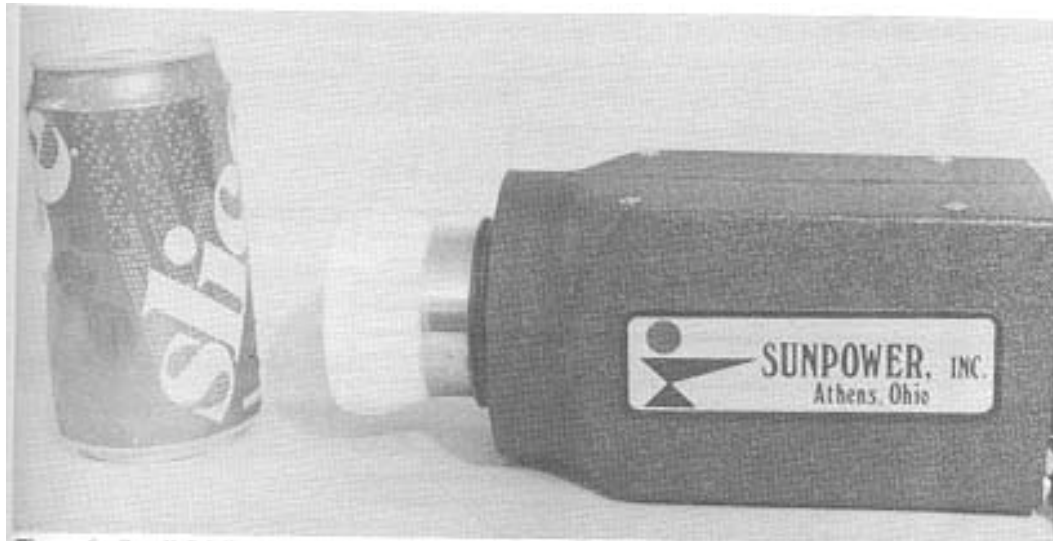

Figure 6 - Small Stirling cooler capable of lifting 35W at -50°C

Figure 6 - Small Stirling cooler capable of lifting 35W at -50°C

Maximized performance for single stage machines lifting less than 100W and operating below -25°C (248K) is probably limited to around 60% of Carnot. At temperatures below about 100K the maximum fraction of Carnot tends to drop off from a likely figure of around 40%. Practical considerations associated with cost would reduce these numbers to some extent. Increasing frequency will also eventually have a deleterious effect on efficiency. At some point the reduction of size with increasing frequency is off set against the increase in size due to poorer efficiency. An exercise to design a miniature free-piston Stirling cooler for 80W lift at -50°C resulted in the hypothetical high frequency machine shown in Figure 8. Overall size is extremely small for a cooling machine of this capacity. The configuration and performance is similar to the 60Hz cooler shown in Figure 4 with the exception that the specific capacity has been increased from 16W/kg to 40W/kg.

MINIATURE STIRLING COOLERS

D. M. Berchowitz



Figure 7 - Small cryocooler capable of lifting 4.0W at 77K (developed for high temperature superconductor applications)

SUMMARY

The free-piston Stirling offers the best choice for electronic cooling on the basis of reliability, size and performance. Cost estimates completed for larger machines would suggest that the Stirling may well be competitive in this area as well [5]. Exploratory applications are currently underway, a good example of which is the radar demonstrator shown in Figure 9. This unit, designed by Superconductor Technologies Inc. (STI), uses a small military-type Stirling (Hughes model 7050H-1SIA) to cool a high temperature superconductor delay line down to 80K. Though this exercise clearly demonstrates the merit of the Stirling cooler, military units are usually reliable for only a few thousand hours of operation. For an application of this nature, product life would need to be greatly improved while keeping cost below \$2000 [7]. The machine shown in Figure 7 is designed to meet these needs. Lift has been increased by almost a factor of four while increasing the mass of the cooler by only 20%. Specific capacity improvement has been achieved partly by improving the cycle efficiency but mainly by the use of higher frequency. Though further improvements are still possible in this regard, low temperatures tend to limit the operational frequency for which the machine can be expected to operate efficiently.

MINIATURE STIRLING COOLERS

D. M. Berchowitz

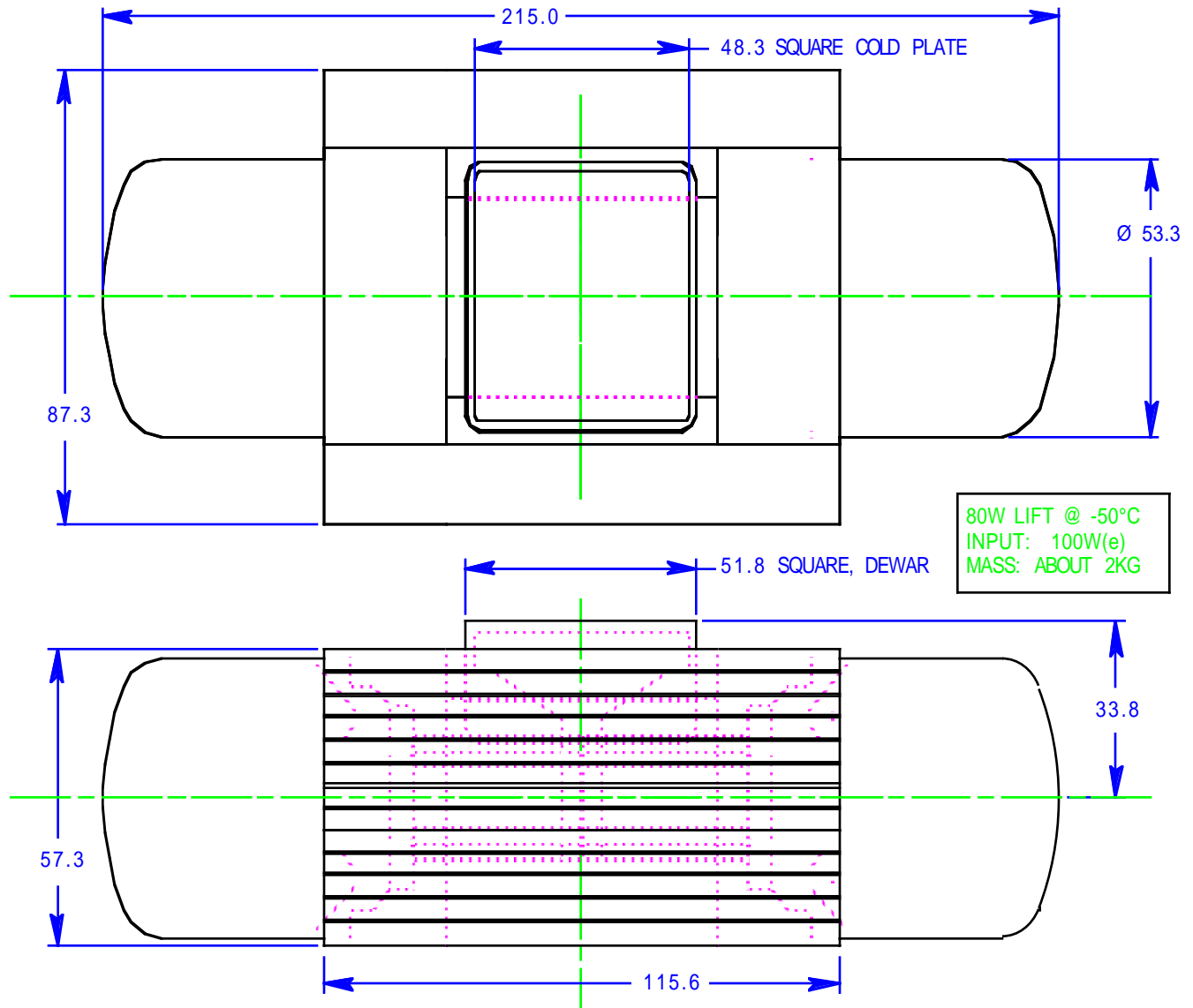

Figure 8 - Miniature free-piston Stirling cooler capable of lifting 80W at -50° C with 100W input (dimensions in mm).

The extent of miniaturization possibilities at warmer temperatures shows much more promise. Studies presently being undertaken suggest that for low lifts the operational frequencies may be greatly increased without sacrifice of thermodynamic performance. Mechanically, the ability of the free-piston configuration to operate reliably at far higher frequencies than crank machines is the other important ingredient. Some warm temperature comparisons suggest that the free-piston Stirling preserves performance far better than does the Rankine for small low lift applications. The eventual limitations dictated by heat flux demands will limit the process of size reduction. Where this boundary lies is still an unanswered question though some speculative ideas suggest that the Stirling may be miniaturized to the point of incorporating it directly into the silicon structure of a microprocessor [8].

MINIATURE STIRLING COOLERS

D. M. Berchowitz

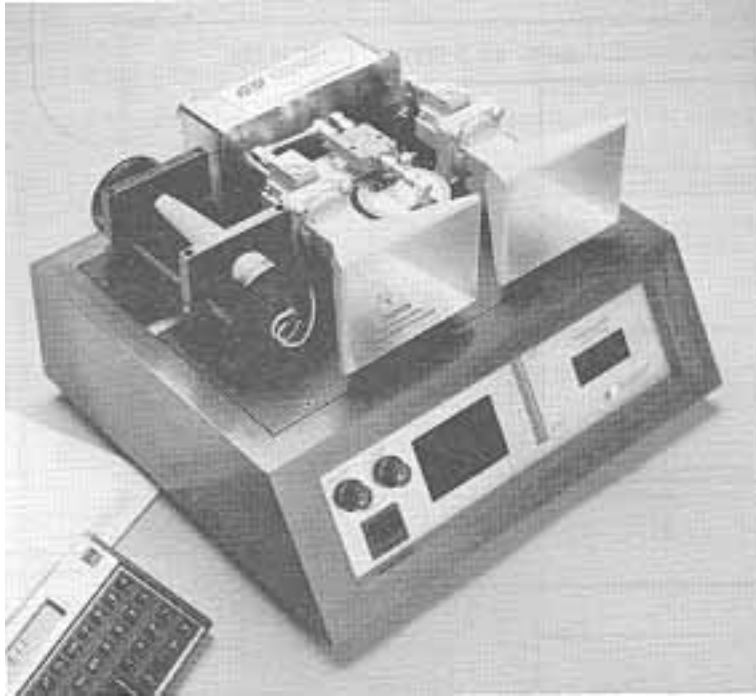

Figure 9 - Radar demonstrator using high temperature superconductor delay line cooled by small Stirling (courtesy STI)

REFERENCES

1. Walker G. *Cryocoolers*, New York: Plenum Press, 1983.
2. Berchowitz D.M. and Shonder J. "Estimated Size and Performance of a Natural Gas Fired Duplex Stirling for Domestic Refrigeration Applications", XVIII th International Congress of Refrigeration Inc., Montréal, Canada, August 1991.
3. Beale W.T. "Free-Piston Stirling Engines Some Model Tests and Simulations", SAE Cong, Detroit, MI, Jan 13-17, 1969. Also SAE paper 690230.
4. Berchowitz D.M. "Free-Piston Stirling Coolers", International Refrigeration Conference - Energy Efficiency and New Refrigerants, Purdue University, July 1992.
5. Berchowitz D.M. and Bessler W.F. "Progress on Free-Piston Stirling Coolers", 6th Int. Stirling Engine Conference and Exhibition, Eindhoven, The Netherlands, Proc., Univ. of Rome, May 1993.
6. Fabien M.J. "Evaluation of the Free-Piston Stirling Cycle for Domestic Cooling Applications", XVIII th International Congress of Refrigeration Inc., Montréal, Canada, August 1991, pp 839-843.
7. Kapolnek D.J. *et al.* "Integral FMCW Radar Incorporating an HTSC Delay line with User Transparent Cryogenic Cooling and Packaging", Superconductor Technologies Inc., Santa Barbara, California, 1992.
8. Walker G. and Bingham E.R. "Micro and Nano Cryocoolers: Speculation on Future Development", 6th Int. Cryocooler Conf. Plymouth, Mass., Oct 1990, pp 363-375.



"Changing the Way the World Cools"



welcome to the homepage of Global Cooling!

[Global Cooling](#) develops innovative refrigeration solutions. For example, the [Free-Piston Stirling Cooler](#) developed by Global Cooling has a high energy efficiency and uses earth friendly cooling substances. If you feel your refrigeration products are in need of major innovation, please [contact us](#). Together we can change the way the world cools!



did you know...

John Ericsson, the inventor of marine screw propellers and gun turreted warships and the designer of the famous civil war era Monitor was also the inventor of the high performance wire mesh regenerator used in modern Stirling engines and cooling machines. Indeed, the largest Stirling engine ever constructed was designed by Ericsson for use in the ship of the same name Ericsson. Even more amazing is that he constructed the first solar driven Stirling engine using a parabolic reflector in

Latest Updates!!

October 21, 2008

Global Cooling's newest portable freezer, the SC-UL25, is scheduled for public release in late Q4 2008. The new freezer will be capable of reaching temperatures below -95°C while drawing power from an automobile 12VDC cigarette lighter. Maximum power consumption is typically around 150-180Watts (comparable to headlights). The unit



[Global Cooling M100/150 FPSC](#)

currently weighs in at less than 35lbs and has a cargo capacity of just under 1cu.ft..This revolutionary new product allows for unprecedented new capability in the Ultra-Low Temperature Transport and Storage industries and will be the first in a complete line of FPSC based ULT freezers scheduled to be released over the next 24-36 months.

about 1870.



Twinbird FPSC/Module

March 3, 2008

The latest version of Global Cooling's revolutionary new Ultra-Low temperature Freezer, The SC-UL25, was unveiled at the Pittcon 2008 show in New Orleans. The newest version has been upgraded with VIP insulation and an increased cargo volume. Now a 25L (0.9 cu ft) capacity with a low temperature capability of -92 degrees C vs. the original SC-UL20's 20L (0.7 cu ft) and -80 deg C capability and expanded foam insulation. This enhancement was accomplished without changing the exterior envelope or system mass. The current beta prototypes are undergoing final modifications and testing with product launch scheduled for Q4 2008. The new SC-UL25 provides precision temperature control, programmable rate cooling and an integrated heating element to provide not only the Worlds first truly portable Ultra-Low temperature freezer but also the Worlds first truly portable environment chamber capable of temperatures ranging from -92 deg. C to 110 deg C. The SC-UL25 requires only 12V DC 12.5A input power and uses less than 150W of power to maintain an internal temperature of -80 deg C in a 25 deg C environment. In fact, the new SC-UL25 can be powered by most standard cigarette lighter/ Accessory ports available in modern automobiles. This puts the total power consumption of the SC-UL25 at an order of magnitude below the typical power consumption of small - 80 deg C class freezers!



Portable High Performance Refrigerator/Freezers/ ULT Freezers



Global Cooling Electronic Expansion Valve

Archive

©2004 - 2008 Global Cooling - 141 North Columbus Road - Athens, Ohio 45701 USA - (740) 592-2655 - info@globalcooling.com

Welcome to
globalcoolingjapan.com

Related Searches: [Stirling Motor](#) [Stirling Engines](#) [Stirling](#) [Kyoto Global Warming](#)

[Buy this Domain](#)

Sponsored Listings

- [Stirling Motor](#)

➔ [Global Warming Effects](#)

Facts & News Stories Surrounding Today's Most Important Global Issue

[www.FT.com/climate](#)

 - [Stirling Engines](#)
- [Global Warming](#)

➔ [No Global Warming](#)

No significant warming since 1995 Read in Facts & Arts

[www.factsandarts.com](#)

 - [Kyoto Global](#)
- [Japan Real Estate](#)

➔ [Executive Apartment Tokyo](#)

Owner of 2100 exclusive apartments in the heart of Tokyo. No agent fee

[www.suinitomolabour.jp](#)

 - [Global Warming](#)
- [The History of Japanese tea](#)

➔ [Japanese tea](#)

All about the japanese tea culture The best teas of Marukyu Koyamaen

[japantea.hu](#)

 - [Glaciers Melting](#)
- [Melting Ice Age](#)

➔ [Global Warming?](#)

What is the Christian view on Global Warming? Read now.

[ChristianityToday.com/ct](#)

 - [Arctic Warming](#)
- [Arctic](#)

➔ [Climate Change MediaWatch](#)

Weekly Updates on News Coverage Trends, Analyses & Visualizations

[www.ecoresearch.net/climate](#)

 - [Albedo Effect](#)
- ➔ [Newsweek articles](#)

MyWire - current & archived articles from premier publications.

[www.MyWire.com](#)
- ➔ [Rizubi Used Cars Japan](#)



Used Cars Exporter, Auction Agent Japan Used Cars & Const.Equipment

www.rizubi.com

 [Golf shop - Made in Japan](#)

Nippon shaft, Diamana, and Honma! All on Sale - Lowest prices Ever

www.tourspecgolf.com/proshop

 [Environment and aviation](#)

Interactive animation on the aviation industry's actions

www.enviro.aero/TheFlightPath

BRIEF HISTORY OF STIRLING MACHINES

1 Background

In the early 1970's, the uncertainty of energy costs and supplies and the increasing awareness of pollution made it important to investigate alternative prime movers. Major requirements for these devices are that they be efficient, non-polluting, reliable, economical and socially acceptable. The development and utilization of such systems may be of huge consequence. Widespread use of efficient prime movers are likely to have a considerable effect on the balance of payments for countries that import significant energy supplies.

However, aside from occasional price spikes, fuel costs have generally been low since the 1980s (particularly for the major industrial nations) and the pressure to find alternate low cost energy efficient prime movers has been to a large degree relegated to secondary considerations. The low cost of fuel has unfortunately hastened the problems of global pollution. The accumulation of CO₂ in the atmosphere is expected to produce a green house effect by insulating the earth and thus increasing the mean global temperatures. This, in turn, could eventually result in cataclysmic weather changes and even the melting of the polar ice caps. Another serious problem facing humanity in the near term is the accumulation of chlorofluorocarbons (CFCs) in the upper atmosphere. These compounds are broken down by ultraviolet light into highly reactive compounds that eventually consume vast quantities of the protective ozone layer. Prompt action by the industrial nations has led to the phasing out of the most dangerous of these compounds and future treaties are expected to further curtail CFC and hydrochlorofluorocarbons (HCFCs) production. CFCs and HCFCs are the compounds of choice in refrigeration and air conditioning and other applications of heat pumping. More recently even the latest alternative hydrofluorocarbon (HFC) refrigerants have been found to be formidable global warming agents and are now under scrutiny for potential banning.

The Stirling cycle machine, which can operate as either an engine or a heat pump, has

aroused much interest because of its many favorable characteristics. These include:

- i) Minimal pollution. In the case of an engine, the exhaust gases are comparatively clean and cool.
- ii) Silent and practically vibrationless operation in some configurations.
- iii) Potential for low fuel or energy consumption. The maximum attainable efficiency or COP for any heat engine operating between the same temperature differential.
- iv) Multi-fuel capability. The energy source may be almost of any form whatever, so long as it is available at a sufficiently high temperature. Stirling engines have been run on solar energy and a variety of liquid and solid fuels. This applies to heat pumping as well by the use of the duplex configuration.
- v) In many instances, it is possible to hermetically seal the machine thus eliminating problems arising from dirt ingress. Some of these configurations have demonstrated operating lives exceeding 10 years.
- vi) Reversible operation allowing the same device to be used as an environmentally friendly wide temperature range refrigerator or heat pump. This feature also introduces the possibilities of regenerative braking.
- vii) Reasonable specific power (currently between 0.067 kW(e)/kg for higher power engines down to 0.033 kW(e)/kg for lower power engines). As a low capacity heat pump (up to a few hundred Watts), the specific lift is considerably better than other heat pump technologies (30 to 40 W/kg).
- viii) Favorable torque characteristics for transportation applications. This leads to simpler transmission designs.
- ix) Mechanical simplicity. In some configurations gas bearings are easily implemented thus avoiding the need for oil lubrication.
- x) The highest specific work output of any closed cycle.

2 The Stirling Cycle

The Carnot theorem (*Reflexions sur la Puissance Motrice du feu, et sur les Machines Propres a Developper cette Puissance. Par S Carnot, 1824*) states that the efficiency of all

reversible engines operating between the same two temperatures is the same, and no irreversible engine working between these two temperatures is able to have a higher efficiency.

This statement was later shown by Clausius and Kelvin to be a necessary consequence of the Second Law of Thermodynamics. The process during which heat is transferred must be done isothermally. Thus, the two temperatures referred to by Carnot are the higher temperature at which heat is added reversibly, and the lower temperature at which heat is extracted reversibly. The processes connecting the heat addition to the heat extraction must then be externally adiabatic when taken together, and must obviously be reversible as well to achieve a cycle that is completely reversible.

The cycle suggested by either James or Robert Stirling (there appears to be some contention here) in 1816 was originally envisaged as a perpetual motion engine of the second kind, that is, all the heat supplied would be converted to work. This misconception of the possibility of perpetual motion is borne out by the fact that the first Stirling patent of 1816 (*Improvements for Diminishing the Consumption of Fuel, and in Particular an Engine Capable of being applied to the moving of Machinery on a Principle Entirely New*) did not include a cooler --- only a heat source was indicated (Figure 1). The omission was corrected in later patent disclosures.

The Stirling cycle is a closed cycle in which a fixed mass of gas is alternately expanded, cooled, compressed and reheated to the beginning of the expansion phase. Figure 2 shows the two most common mechanical configurations for realizing the Stirling cycle, known respectively as the dual piston and piston-displacer arrangements, or more commonly as the alpha and beta arrangements. The processes of heating and cooling are appreciably augmented by what Stirling called an *economizer*. This device, of which he was the first to use, functions on a principle that is now known as regeneration. The economizer, or regenerator, is an energy store; it generally consists of a matrix of fine wires, porous metal, foil or sometimes simply an annular gap. It serves to store unspent heat from the expanding gas as the gas leaves the hot section and to transfer this heat back to the

compressed gas as the gas returns from the cold end. The regenerator substantially improves the efficiency of the cycle. Following the process in Figure 2, it can be seen that if the expansion and compression spaces can be made isothermal at their respective temperatures and the regeneration perfect, then the Stirling engine fulfills Carnot's requirements for maximum attainable efficiency. That is, all the other processes are externally adiabatic and ideally reversible.

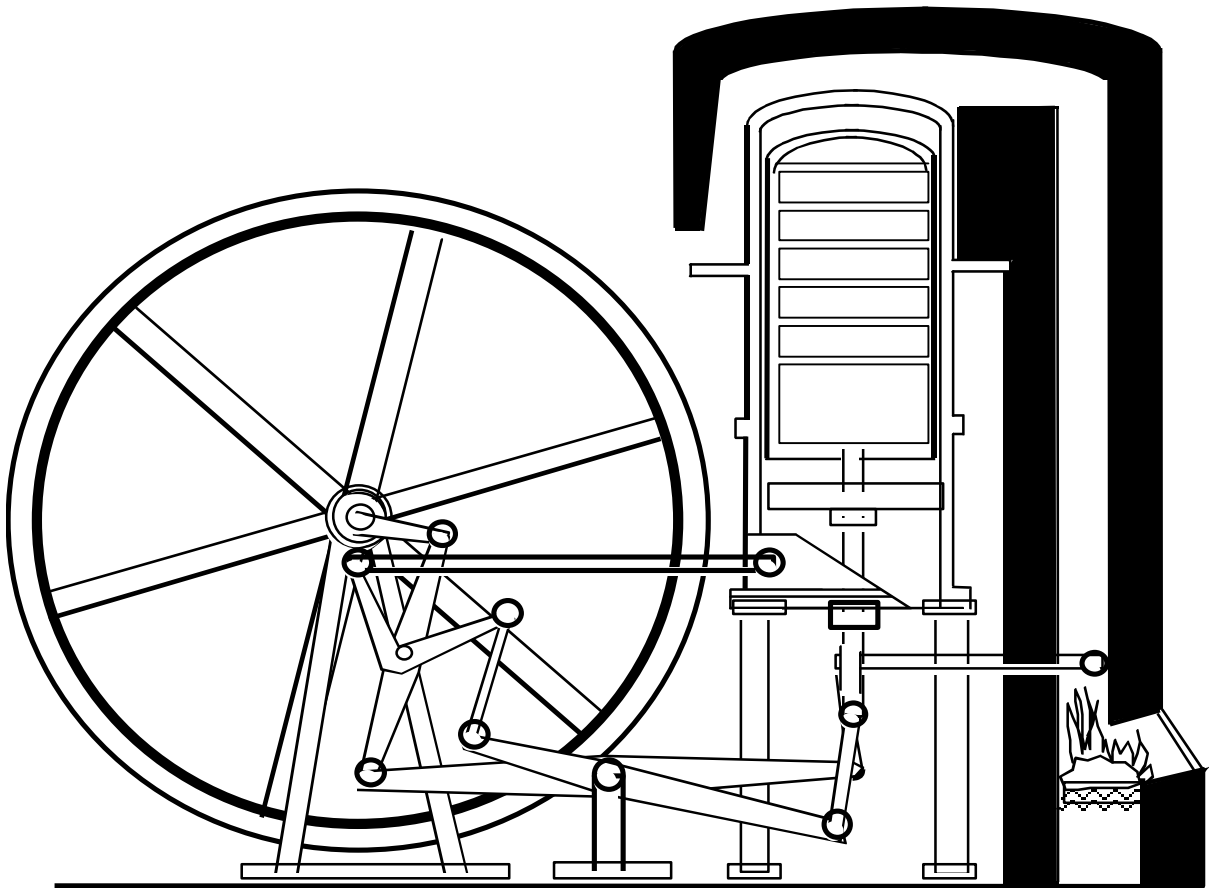

Figure 1 The Original Stirling Engine Patent of 1816 (after Walker 1973). Note no distinct cooler is indicated

Whereas it is difficult to even approach isothermal conditions in the working spaces with conventional heat exchanger technology, regenerators regularly obtain efficiencies greater than 98%. Therefore, and especially in machines of 0.5kW and above, separate

heat exchangers for the heater and cooler are introduced as shown in Figure 3. It is more plausible then, to imagine that the ideal cycle would have an isothermal acceptor (heater) and rejector (cooler) while the working spaces would be adiabatic. This configuration has been referred to as the pseudo-Stirling cycle [Rallis *et al* 1977] or sometimes as the adiabatic Stirling cycle, and is generally considered more representative of what may be understood by the ideal cycle *yardstick*. Despite this argument, it is still held by many that the ideal cycle representing all Stirling machines is the one with isothermal working spaces and ideal heat exchangers.

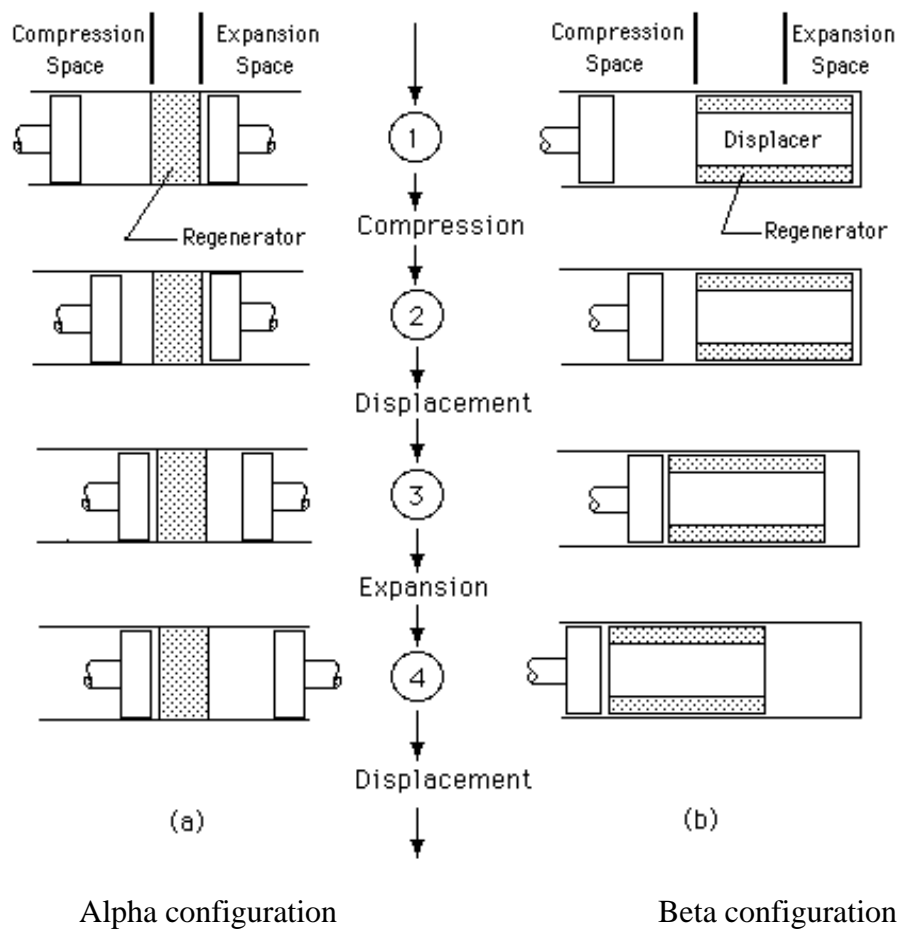

Figure 2 Piston and Displacer Motions

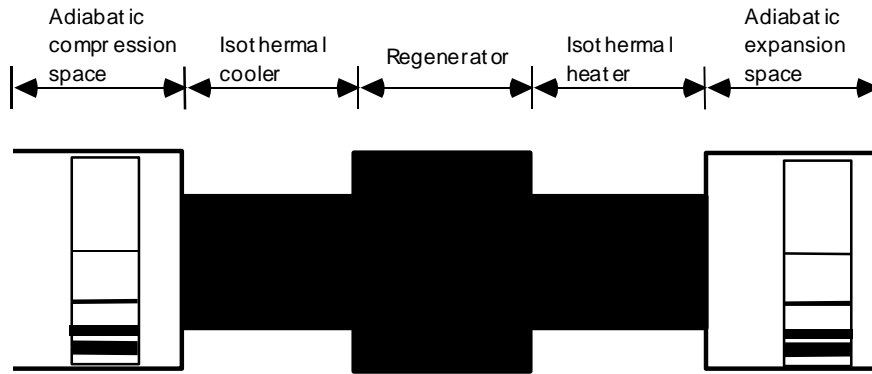

Figure 3 The Pseudo-Stirling or Adiabatic Stirling

3 Mechanical Configurations

The mechanical configurations of Stirling machines are generally divided into three groups known as the alpha, beta and gamma arrangements. Alpha machines have two pistons in separate cylinders that are connected by a rejector, regenerator and acceptor (as in Figure 3). Both beta and gamma machines use displacer-piston arrangements, the beta device having both the displacer and piston in the same cylinder whilst the gamma machine has separate cylinders for the displacer and piston. The alpha and beta arrangements are indicated in Figure 2 and the gamma arrangement in Figure 4.

Drive methods may be broadly divided into two groups, namely the kinematic and free-piston drives. Kinematic drives may be defined as a series of mechanical elements such as cranks, connecting rods and flywheels which move together so as to vary the volumes of the working spaces in a prescribed manner. This may be considered as the conventional method by which reciprocating heat engines (or heat pumps) deliver (or accept) their thermodynamic work to (or from) an output shaft. Free-piston drives, on the other hand, use a combination of the working gas pressure variations and springs to move the reciprocating elements. In this case, a linear alternator (or motor), hydraulic pump or a second free-piston Stirling device transfers the work. From an analysis standpoint, it is important to distinguish between free-piston and kinematic machines in that the mechanical dynamics and thermodynamics are strongly coupled in free-piston

arrangements. In kinematic machines, for given operating conditions, only the volumes changes need be defined in order to determine the machine's performance.

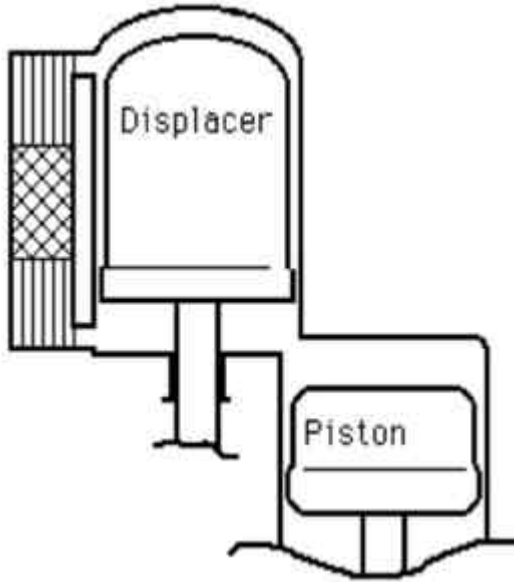

Figure 4 The Gamma Arrangement

4 Applications to Prime Movers

Stirling cycle engines were in wide use up to the beginning of the First World War. The most attractive features in those days were the inherent simplicity of the machine, its ease of maintenance and its safety. Safety was an important consideration since the early steam engines could compete favorably on almost all other grounds but had unreliable boilers that had an alarming tendency to occasionally explode. Surprising, as it may seem for those days, efficiency was also a consideration. Coal, the chief energy source had been climbing in price ever since the beginning of the Industrial Revolution. Typically, an overall efficiency of 7% could be obtained with a Stirling engine and this was considered quite competitive, indeed, even today, this would be respectable in many applications. Table 1 lists the performance of some early Stirling engines.

Table 1 Air Engine Trials (taken from Donkin 1896)

Air engine	Bore (mm)	Stroke (mm)	Speed (RPM)	Indicated power (kW)	Brake power (kW)	Consumption of coal per hour (kg)	Mechanical efficiency (%)	Overall efficiency (%)*
Buckett	610	406	61	15.06	10.73	16.59	71	7
Bailey	373	175	106	1.77	0.98	4.52	55	2
Bénier	340	350	117.6	4.36	3.00	6.59	69	5
Stirling	406	1219	-	30.00	-	45.40	-	7†
Ericsson	4.3m	-	-	239.00	-	262.30	-	10†

*Based on average heating value of 32.5MJ/kg. †Indicated efficiency for these numbers.

In 1876 Otto presented his now famous Otto cycle engine. These engines were safe, reliable and, very importantly, had excellent specific power ratings which allowed them to be easily incorporated in motor driven transport. To further complicate matters for the Stirling engine, the Otto engines were cheap to run owing to their higher efficiencies and cheaper fuels. Broadly speaking, an Otto cycle's efficiency is dependent on its compression ratio, while that of the Stirling cycle is dependent on the temperature ratio of the hot and cold ends. Owing to material limitations back then, early Stirling engines could not operate at the high temperatures necessary to ensure good efficiency. Furthermore, these early Stirling engines did not often employ combustor preheaters (also called recuperators), resulting in exhaust temperatures that were unnecessarily high with consequent further reduction in overall efficiency. On the other hand, it was a fairly simple matter to design an Otto engine such that it operated with a compression ratio commensurate with good efficiency. Thus the rising successes of the early Otto engines and the introduction of boiler codes that made steam engines safe soon overwhelmed the technologically infant Stirling engine. Even in these circumstances though, in the remoter areas of the world, the Stirling engine enjoyed a longer success¹. Here the Stirling's ability to burn almost any fuel helped grant the engine a longer stay.

The recent interest in the Stirling engine's high theoretical efficiency has been encouraged

1. For example, Stirling engines were used in India until recently - and it is still possible to purchase old engines there.

by the uncertain supply of primary energy sources. Many governments and organizations have committed considerable research efforts into the development of practical Stirling type devices. As it now stands, the most significant advantages of the Stirling engine are its multifuel capability (for example, its ability to burn solid fuels), its potential for ultra high reliability, high efficiencies at low to intermediate power levels and low emissions. An application that takes advantage of these characteristics is the new field referred to as micro-cogeneration². Cogeneration systems generates on-site electrical power while fulfilling the site demands for heating from the waste heat generated by the prime mover. Silent operation and long life are important requirements. Figure 5 shows a prototype 1 kW free-piston Stirling engine (FPSE) developed specifically for this promising application.



Figure 5 Sunpower Prototype 1 kW FPSE for Micro-Cogeneration Applications.

² N. W. Lane and W. T. Beale. "Stirling Engines for Gas Fired Micro-Cogen and Cooling", Strategic Gas Forum, Detroit, Michigan, June 19-20, 1996.

5 Applications to Heat Pumping

The Stirling cycle was applied to the business of producing cold somewhat after it was first used as a prime mover. In 1834, John Herschel is said to be the first to use Stirling's machine for refrigeration purposes. From descriptions published in 1876 by Alexander Kirk, it seems that by then Stirling cycle cooling was well known in technical circles. Much later, beginning in the 1946, the cycle was applied by Philips under the direction of J. W. L. Köhler for deep temperature use in order to generate liquefied gases [Hargreaves 1991]. Machines based on this principle are able to obtain temperatures down to 12K. In 1957, T. Finkelstein published an investigation done for English Electric where he showed that the Stirling could compete favorably with vapor compression systems for domestic refrigerator applications. Further work in this area was conducted at Sunpower in the 1989 to 1995 timeframe. A refrigerator using the horizontally opposed arrangement, for example, was successfully flown on space shuttle *Discovery* in 1992. This unit is shown in Figures 6 and 7.



Figure 6 Horizontally Opposed Arrangement (Boxer)

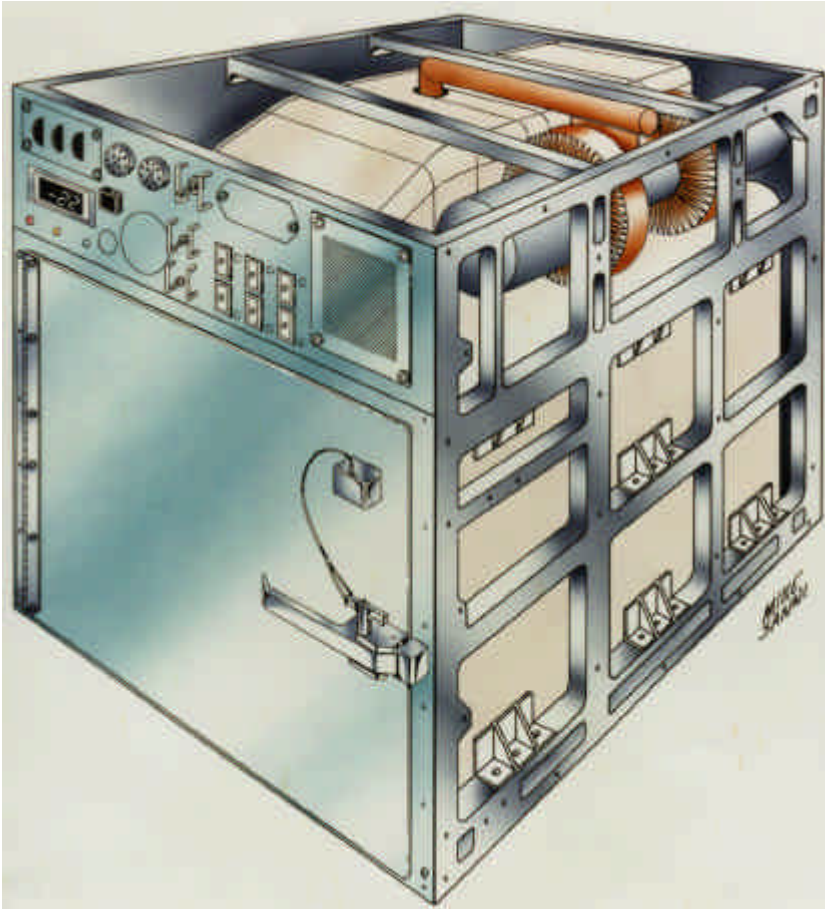

Figure 7 Boxer heat pump installation in Space Shuttle refrigerator

More recently a number of free-piston cooling machines spanning many different applications have been developed (see, for example www.sunpower.com). Figures 8 and 9 show two examples of small free-piston coolers.



Figure 8 Free-Piston Cooler for Portable Refrigerators (www.twinbird.co.jp)



Figure 9 M77 Free-Piston Cryocooler. Lift 4 W at 77 K (www.sunpower.com).

A relatively new field of applications has been opened by a practical demonstration of the duplex Stirling configuration. The duplex Stirling system involves two free-piston Stirling machines in a back-to-back arrangement (Figure 10). One machine operates as a heat engine and drives the other that then operates as a heat pump. William Beale, then at Ohio University, first suggested this idea in 1965. Immediate applications include gas-fired food freezers, domestic gas-fired heat pumps and natural gas liquefaction. Of these the more intriguing is that of natural gas liquefaction. There are many remote gas wells of low yield where it is uneconomical to pipe the gas to a central distribution network. In these cases, the duplex Stirling would enable the natural gas to be liquefied on site in a self-contained system. A container vehicle would then periodically transport the liquefied gas to a central distribution point. Yet another application of this idea would be the advantage of having a ready supply of liquid fuel --- either domestically or in the work place. Here a duplex Stirling system would hook up to a gas line for on-line liquid gas production. Liquefied gas is stored in less space than pressurized gas and is an ideal motor fuel in situations where its cost is competitive with petroleum distillates. Such a system was prototyped at Sunpower Inc in 1982 and is shown in Figure 11. From the energy balance and given average natural gas properties, a yield of 3.3kg liquefied to 1kg burned was envisaged.

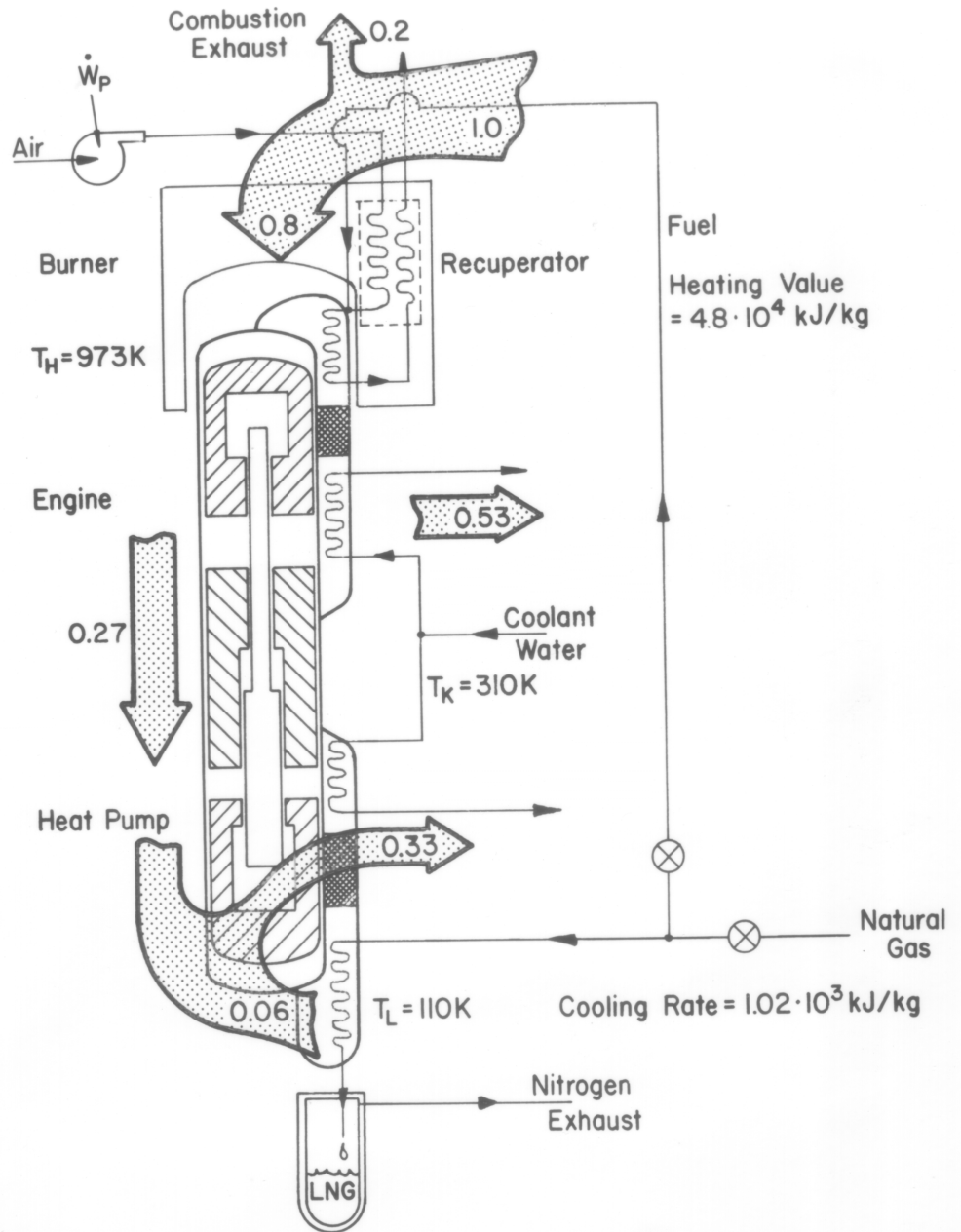

Figure 10 Yield of Natural Gas Liquefier

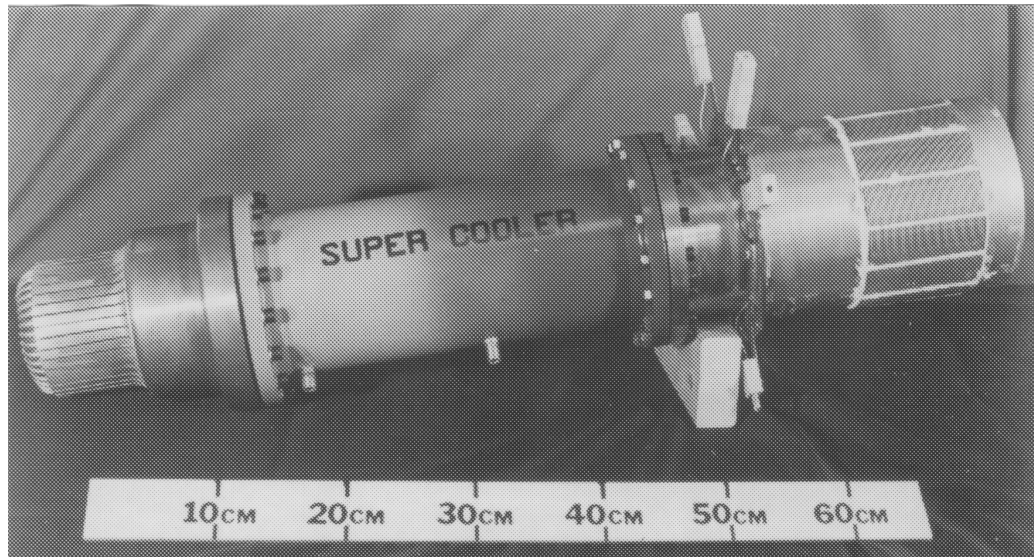

Figure 11 Free-Piston Duplex Stirling Machine

6 Recent Developments

A number of companies in the US, Japan and Europe have begun to re-evaluate the Stirling for a wide range of applications. Aside from those already mentioned, modern cooling and refrigeration requirements favor the Stirling in many situations where vapor compressor systems have been found wanting. For example, microprocessor speed is known to be inversely proportional to the average absolute temperature of the chip. Therefore, being able to cool the microprocessor to some decently low temperature would allow substantial speed gains for computers. Another example is in application to infrared detectors whereby their sensitivity is improved by cooling. Deep-freezing of biological tissue is yet another application and so on.

In 1995, Global Cooling BV (GCBV) was founded with the express purpose to develop free-piston Stirling coolers (FPSCs) for application to consumer and commercial refrigeration applications. In 2002 GCBV and Sunpower, Inc, joined forces to address cooling opportunities made available by many modern day requirements. We do this by a combination of licensing and manufacture. Today GCBV and its licensees make available small FPSCs for use in any number of industrial, commercial and consumer applications.



The Outdoor Company™

▶ **Web Store**

- All
- Tents
- Stoves
- Roadtrip Grills
- Lighting
- Backpacks
- Sleeping Bags
- Coolers
- Inflatables
- Heaters



The Outdoor Company™

- Furniture
- Marine
- Order Parts
- Online Outlet Store

▶ **Outdoor Experts**

- Gear Finder
- Buyer's Guide
- Outdoor Adventure Guide
- Outdoor Ambassadors
- Outdoor Advocate
- Checklists
- FAQs
- Downloads
- Web Store



The Outdoor Company™

- Find a Dealer
- Factory Outlets
- Contact Us
- Order Tracking
- Careers at Coleman

[Web Store](#) | [Home](#)

[Online Outlet](#) | [Order Parts](#) | [Non-Profit](#) | [Family Store](#) | [Factory Outlets](#) | [Order Tracking](#)



Product No Longer Available

Coleman®

Stirling Power Cooler

Model No. 5726-750



Click on image for larger view

- Newsroom
- Warranty Information
- Coleman History
- Privacy Policy
- Sister Sites

► **Coleman Services**

- Order Tracking
- Gear Finder
- Product Manuals
- Buyer's Guide
- Recycling
- Warranty Information
- Safety Information



Sign Up for Email



0 items in your cart

.....

CONSUMER SERVICE

1.800.835.3278

.....

GREAT DEALS ON COLEMAN GEAR
WHILE SUPPLIES LAST
DON'T MISS OUT

Hot Deals

- 26 Qt., holds up to 37 cans
- The most powerful, portable cooler/freezer in its class
- Keep items frozen in temperatures over 100°F outside
- Completely portable - light weight, quiet operation
- Runs on either 12v or 110v (adaptor included)
- Easy to use control panel with low battery indicator
- Adjustable with 5 temperature control settings (3 cool/2 freeze modes)
- Fast, efficient cooling times uses little battery power
- Environmentally friendly - no CFCs or harmful refrigerants
- Perfect for RV's, boating, camping, cabins, home, or office
- Outside Dimensions: 27.3" X 18.1" X 13.7"
- Inside Dimensions: 13.1" X 8.6" X 13.5"
- 1 year limited warranty

[Coleman® Stirling Power Cooler](#)
[Product Manual](#)

[Find Coleman Repair Parts](#)

See Product Information for more details.

Looking for more information on products, or product repairs? OR, looking for helpful hints on purchasing outdoor gear? You're in the right place.

[Gear Finder](#)

[Buyers Guide](#)

[Checklists](#)



Coleman \$50 Gift Card

\$50.00



CR123A Lithium Pack-Away Lantern

\$59.99



**StormBeam™
Dynamo Lantern**

\$29.99

FREE SHIPPING
ON ORDERS OVER \$50
USE "8HGFS11" AT CHECKOUT
CLICK HERE FOR MORE INFO
Offer expires 11/21/08

FAMILY COMING FOR THE HOLIDAYS?



COLEMAN® AIR BEDS



GREAT COLEMAN® GIFT IDEAS FOR THE WHOLE FAMILY

COLEMAN GIFT CARDS FOR THE COLEMAN FAN IN YOUR FAMILY



[Home](#) / [Camping Gear](#) / [Order Parts](#) / [Order Tracking](#) / [Gear Finder](#) / [Manuals](#) / [Coleman Factory Outlets](#) / [Contact Us](#) / [Site Map](#) / [Employment](#) / [Coleman History](#) / [Privacy Policy](#) / [Terms of Use](#) / [Sister Sites](#) / [Why Buy Coleman®?](#) / [Recall](#) / [Licensing Opportunities](#) / [Coolers](#) / [Tents](#) / [Sleeping Bags](#) / [Stoves](#) / [Lighting](#) / [Heaters](#) / [Airbeds](#) / [Outdoor Adventure Guide](#)
Consumer Service 1-800-835-3278 • ©2000-2008 The Coleman Company, Inc.



Hochschule Reutlingen
Fakultät Technik
Maschinenbau

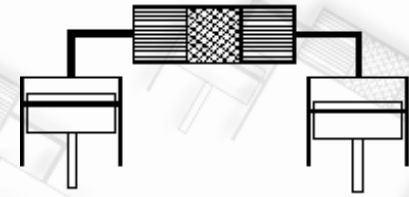

Prof. Dr.-Ing. Bernd Thomas

- [Home](#)
- [Literaturverzeichnis](#)
- [Forschung](#)
- [Projekt "Mini-BHKW"](#)
- [BWPLUS Projekt](#)
- [PROSA](#)
(Version 2.4 / 3.0)
- [Kontakt](#)
- [Buch "Mini-BHKW"](#)

 [English version](#)

PROSA

Programm zur Berechnung regenerativer Gaskreisprozesse

aktuelle Versionen: [PROSA 2.4](#) [PROSA 3.0](#)

Copyright ©, Alle Rechte vorbehalten

PROSA (**P**rogram for **S**irling machine **A**nalysis) ist ein Computerprogramm zur Berechnung von Stirling Maschinen, die als Kraft-, Kältemaschine oder Wärmepumpe Anwendung finden. Es lassen sich verschiedene Zylinderkonfigurationen (u.a. auch die Siemens-Konfiguration), Wärmeübertrager- und Regeneratortypen sowie Arbeitsgase für die Berechnung auswählen. Außerdem enthält PROSA eine Variations- und eine Optimierungsroutine, die eine optimierte Auslegung von Stirling Maschinen erlauben, und es kann zwischen deutscher und englischer Sprache umgeschaltet werden.

Die grundlegende Idee für PROSA besteht darin, ein Programm zu entwickeln, das ein hohes Maß an Bedienungsfreundlichkeit besitzt, so dass auch wenig erfahrene Anwender das Programm nach kurzer Einarbeitungszeit verwenden können. Dessen ungeachtet soll jedoch die Aussagefähigkeit und Genauigkeit der Berechnungsergebnisse sowohl die Nachrechnung bestehender Maschinen als auch die Auslegung neuer Maschinen ohne weitere Rechnungen bzw. Korrekturen ermöglichen. Weiteres Ziel ist ein modularer Programmaufbau, um neue Komponenten, wie z.B. andere Wärmeübertragerbauarten in einfacher Weise integrieren zu können.











Das Programm PROSA existiert mittlerweile in 2 Varianten: Die **Version 2.4** ([pdf-Info](#)) basiert auf einem Berechnungsmodell 2ter Ordnung. Diese Art Modelle setzen auf den geschlossenen Lösungen einer isothermen Prozessberechnung (Modell 1ter Ordnung) auf. Die Berücksichtigung sekundärer Verluste sowie die vom isothermen Idealfall abweichenden Temperaturänderungen des Arbeitsgases insbesondere in den Zylinderräumen werden im Rahmen eines Modells 2ter Ordnung nachträglich korrigiert. Mit dem Programm PROSA 2.4 können sowohl Getriebemaschinen als auch Freikolbenmaschinen berechnet werden.

Mit der **Version 3.0** ([pdf-Info](#)) wurden die Berechnungen auf ein differentielles Modell (Modell 3ter Ordnung) umgestellt. Auf diese Weise können die zeitlich

veränderlichen Gastemperaturen und -drücke genauer berechnet werden, was eine verbesserte Aussagefähigkeit der Ergebnisse bewirkt. Zudem ist man mit dem differentiellen Modell nicht mehr auf sinusförmige Kolbenbewegungen beschränkt, die andernfalls als Grundlage für die geschlossenen Lösungen zwingend voraussetzen sind. Somit sind in der Version PROSA 3.0 Module zur Berechnung von Kurbel- und Rhombengetriebe enthalten. Außerdem besteht die Möglichkeit, frei definierte Kolbenbewegungen mit Hilfe einer Datentabelle von einer entsprechenden Datei einzulesen und zu verarbeiten. Zusätzlich können Drehzahlschwankungen über das Momentengleichgewicht an der Kurbelwelle berücksichtigt werden. Die Version 3.0 ist zur Zeit nur für Getriebemaschinen verfügbar.

Welcome to stirmach.com

Sponsored Listings

-  [Mach](#)
Find great deals and save! Compare products, prices & stores.
www.Shopping.com
-  [Riftec GmbH](#)
Friction Stir Welding Engineering and Production
www.riftec.com
-  [RealSimple.com](#)
Easy Solutions, Tips, Meals & More. Life is Complicated. Simplify.
RealSimple.com
-  [Fond-U-Like](#)
All you need to know about cooking fondues and great fondue recipes
fondulike.tramwayinfo.com
-  [China noodle machines](#)
noodle machines, all types, custom design, good prices, high quality
en.nj-yp.com
-  [Gillette Products](#)
Gillette Products, Buy For Less We ship Worldwide
www.OnlyGillette.com
-  [Quantum Age Stir Wands](#)
Increase Baseline Hydration 28.5% Increase Blood Oxygen 10.33%
theinternethealthstore.com
-  [Cooking Recipe](#)
Easy to make gourmet food. Find food recipe free here...
www.food-recipe.info
-  [Gelato University](#)
Learn to make best quality Gelato at Carpigiani Gelato University!
www.GelatoUniversity.com
-  [Stir Fry Dining Calgary](#)

Related Searches:

- [Steam Engine](#)
- [Steam Engines](#)
- [Steam Power](#)
- [Steam Engine Trains](#)
- [Steam Trains](#)
- [Trains Steam Engine](#)
- [Engine Stirling](#)
- [Stirling And Hot Air Engine](#)
- [Stirling Engine](#)
- [Stirling Motor](#)
- [Locomotive](#)
- [Stir Fry Recipes](#)
- [Soy Sauce Recipes](#)
- [Free Food Recipes](#)
- [All Recipes](#)

Stir Fry restaurants in Calgary, AB Recommendations & special offers.

www.MenuPalace.com

Related Searches:

InsuranceCredit CardsEducation OnlineHotel ReservationDating OnlineDebt Consolidation

This domain may be for sale. [Buy this Domain](#)



**The world leader in free-piston Stirling engines and coolers
and in linear compressors**

Home |

Events

ABOUT

SUNPOWER |

Contact

NEWS

Library

SERVICES

FAQs

TECHNOLOGIES

APPLICATIONS

**NEWS
RELEASES**

**APPLICATION
AND
TECHNOLOGY
BRIEFS**

Sunpower is the world's leading developer of free-piston machines. For over 30 years, Sunpower has provided collaboration, design, application and commercialization of our unique technology to clients worldwide.

Today, Sunpower-enabled products include innovative Stirling engines, coolers, cryocoolers and compressors integrated into environmentally friendly, long-lived, high efficiency solutions. Applications include household refrigerators and cogeneration units, aerospace and military electric generators, medical devices, and nuclear material detection devices.

Sunpower offers technology partnering opportunities, research and development expertise, and a range of high-performing cryocoolers.



182 Mill Street, Athens, Ohio 45701 USA | P.740-594-2221

©2006, Sunpower Inc., All Rights Reserved. **Terms and Conditions** of use apply. **Privacy Policy**
Web site designed and managed by **OffWhite**.



COOL CARGO

クールカーゴ 350 新登場

カゴ車タイプで移動・保冷が容易 ▶詳しくは



WEB窓口

- ▶ ご相談・お問合せ
- ▶ 価格お問合せ
- ▶ カタログ一覧・請求

☎ 0256-92-6173
☎ 0256-93-6168

▶ **産業・開発向け製品** FPSC 冷凍機を使って、製品を開発する方向けパーツのご紹介

重要なお知らせ

- ▶ 適用分野と輸出規制について
- ▶ ユーザー登録のご案内
- ▶ お客様の情報について
- ▶ サイトポリシー

▶ **FPSC 応用製品** 弊社で開発した FPSC 応用製品のご紹介

- ▶ 会社概要
- ▶ 品質方針について
- ▶ 環境方針について
- ▶ サイトマップ

▼ **NEWS**

- [.....2008・9](#) ▼詳しくは...
- [.....](#) ▼詳しくは...
- [.....COOL CARGO.....](#) ▼詳しくは...
.....FPSC.....
.....8・1.....
- [.....12.....2008.....](#) ▼詳しくは...
3.....88,000.....FPSC.....
FPSC.....FPSC.....
- [.....](#) ▼詳しくは...
- [.....](#) ▼詳しくは...
- [.....](#) ▼詳しくは...
- [.....](#) ▼詳しくは...
- [.....FPSC.....SC-UE15.....](#) ▼詳しくは...

- [.....150W•FPSC.....](#)
.....150W•FPSC..... ▼詳しくは…

- [.....](#)
..... ▼詳しくは…

- [•31•](#)
.....FPSC.....31..... ▼詳しくは…

- [•6•EXPO.....](#)
•6•20••6•22••3.....6.....EXPO..... ▼詳しくは…

- [2007•](#)
2007.....CHINA MED 2007..... ▼詳しくは…

- [.....](#)
..... ▼詳しくは…

- [•6•EXPO.....](#)
NEDO.....6•EXPO..... ▼詳しくは…

- [•13•](#)
.....13.....23•26..... ▼詳しくは…

- [2007•](#)
•FPSC.....CHINA MED 2007..... ▼詳しくは…

- [.....](#)
..... ▼詳しくは…

- [COOL CARGO.....](#)
..... ▼詳しくは…

- [-100•FPSC.....](#)
80W.....-100..... ▼詳しくは…

▼▲

[fcfCf“fo•\[fh•H<ÆŠ”Ž®%oiŽĐ](#)

[-{•¶.ÖfWfff“fv](#)

[Top](#) > Twinbird Global

Twinbird Global



A twinbird is a pair of birds.

We like to think that we the producers, and our customers who use our products, are like a pair of birds.

The joy of our customers is our joy.

From this point of view we named the company and the brand name "twinbird."

*International Business Operations Headquarters

Tel:81-256-92-6160/ Fax:81-256-92-7521

Please send your comments about this site from

[here](#)

[ΔPage Top](#)

Copyright(C) 2007 TWINBIRD CORPORATION, All Rights Reserved.

SCHMIDT ANALYSIS FOR STIRLING ENGINES

This Analysis was written by David Berchowitz and Israel Urieli and published in their book "Stirling Cycle Engine Analysis". The analysis was written for engines but applies also to coolers. The difference between the two analysis is that the Rejector (k) in the engine is the lower temperature reject sink and in the cooler is the higher temperature reject sink. The Acceptor is the heat accept in both engine and cooler but corresponds to the lower temperature in the cooler and to the higher temperature in the engine.

Nomenclature

T	Temperature
P	Pressure
M	Mass
R	Gas Constant
V	Volume
W	Work

Subscripts

c	Compression Space
e	Expansion Space
r	Regenerator
k	Rejector
h	Acceptor
sw	swept

A.1 The Schmidt analysis

A.1.1 Background

The apparent conceptual simplicity of the Stirling engine belies its intractability to mathematical analysis. The difficulty of describing even idealized models of the engine in terms of simple closed-form equations is one of the primary reasons for the widespread skepticism and lack of understanding which exists even today.

In Chapter 2 we derived the basic set of equations which describe the Ideal Isothermal model (table 2.1). Gustav Schmidt of the German Polytechnic Institute of Prague published an analysis in 1871 in which he obtained closed-form solutions of these equations for the special case of sinusoidal volume variations of the working spaces (Schmidt 1871). This analysis is still used today as the classic Stirling cycle analysis. It was derived in order to describe the highly successful Lehmann engine shown in figure A. 1. 1. The paper includes a detailed description of the engine and displays a clear insight and appreciation of it. From figure A.1.1 we see that a very long horizontal cylinder *ABC* was used, in which a concentric displacer *L* and power piston *D* reciprocate in accordance with a rather complex driving mechanism. A full size complete Lehmann engine is on permanent display at the Deutscher Museum in Munich, and a clear, modern description of the engine operation has been recently presented by Kolin (1972).

The driving mechanism does not produce sinusoidal motion. Schmidt derived the equivalent mechanism 'which by means of an imagined, infinitely long thrust-rod, would attain the true movement' (sinusoidal motion) of the working and displacer pistons.

The Lehmann engine piston seal was ingeniously constructed similarly to a bicycle pump, allowing limited pressurized operation. 'The working piston is isolated by means of a leather sleeve turned towards the inside. So long as the air inside the machine has a higher pressure than the outside atmosphere, this sleeve effectively prevents the escape of air towards the outside. However as soon as the pressure inside sinks below the ordinary atmospheric pressure, it permits the entrance of external air into the machine.

'The Lehmann arrangement has the advantage that the working piston is in constant contact only with the cooler air, thereby preventing the inward turned leather sleeve from burning!

Schmidt was acutely aware of the advantages of operating the cycle at a higher pressure, and further states. 'Undoubtedly this is the only system which holds any promise for the future, because with high pressure one can use lower temperatures and therefore produce a durable machine.'

Significantly, there is no mention throughout the paper of the importance of the regenerator, even though the use of regenerators in the earlier Ericsson machines was described. In figure A.1.1 we notice that about a third of the cylinder is enclosed by the furnace and the rest of the cylinder by a water jacket. 'The displacer leaves between itself and the wall of cylinder A, the intervening piece B and the heating pot C exactly so much room that the cross section of the circular intervening space is large enough to allow minimal resistance to the passage of the air, and small enough to produce a thin layer of air in order that heating and cooling may be achieved as rapidly as possible.' The Lehmann machine apparently was not fitted with a regenerator. Now, since over the cycle under cyclic steady conditions the net heat transferred to the regenerator is zero, it is conceivable that Schmidt did not appreciate the importance of the regenerator. He refers to the textbook by Zeuner as containing a 'complete, simple and clear theory' of air engines, but in the same textbook Zeuner decries the use of regenerators for air engines (Finkelstein 1959).

A.1.2 The analysis

The approach taken by Schmidt for the analysis follows the Isothermal Analysis used in Chapter 2 quite closely, up to the derivation of the pressure relation given by equation (2.5), reproduced as follows:

$$p = MR \left(\frac{V_c}{T_k} + \frac{V_k}{T_k} + \frac{V_r \ln(T_h/T_k)}{(T_h - T_k)} + \frac{V_h}{T_h} + \frac{V_e}{T_h} \right)^{-1} \quad (\text{A.1.1})$$

The sinusoidal volume variations are given as in equations (2.15) and (2-16) as follows:

$$\begin{aligned} V_c &= V_{c1c} + V_{swc}(1 + \cos\theta)/2 \\ V_e &= V_{c1e} + V_{swe}[1 + \cos(\theta + \alpha)]/2. \end{aligned} \quad (\text{A.1.2}) \quad (\text{A.1.3})$$

Substituting (A.1.2) and (A.1.3) in (A.1.1) and simplifying we obtain

$$p = MR \left[s + \left(\frac{V_{swe} \cos \alpha}{2T_h} + \frac{V_{swc}}{2T_k} \right) \cos \theta - \left(\frac{V_{swe}}{2T_h} \sin \alpha \right) \sin \theta \right]^{-1} \quad (\text{A.1.4})$$

where

$$s = \left[\frac{V_{swc}}{2T_k} + \frac{V_{c1c}}{T_k} + \frac{V_k}{T_k} + \frac{V_r \ln(T_h/T_k)}{(T_h - T_k)} + \frac{V_h}{T_h} + \frac{V_{swe}}{2T_h} + \frac{V_{c1e}}{T_h} \right].$$

Referring to figure A.1.2 we consider the following trigonometric substitutions:

$$c \sin \beta = \frac{V_{swe} \sin \alpha}{2T_h} \quad (\text{A.1.5})$$

$$c \cos \beta = \frac{V_{swc} \cos \alpha}{2T_h} + \frac{V_{swc}}{2T_k} \quad (\text{A.1.6})$$

where

$$\beta = \tan^{-1} \left(\frac{V_{swe} \sin \alpha / T_h}{V_{swc} \cos \alpha / T_h + V_{swc} / T_k} \right) \quad (\text{A.1.7})$$

and

$$c = \frac{1}{2} \left[\left(\frac{V_{swe}}{T_h} \right)^2 + 2 \frac{V_{swe}}{T_h} \frac{V_{swc}}{T_k} \cos \alpha + \left(\frac{V_{swc}}{T_k} \right)^2 \right]^{1/2} \quad (\text{A.1.8})$$

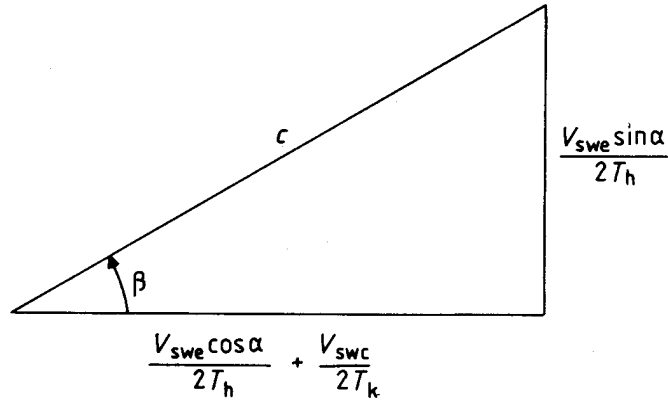

Figure A.1.2 Trigonometric substitutions.

Substituting equations (A.1.5) and (A.1.6) into equation (A.1.4) and simplifying, we obtain

$$p = \frac{MR}{s(1 + b \cos \phi)} \quad (\text{A.1.9})$$

where

$$\phi = \theta + \beta \quad b = c/s.$$

Equation (A.1.9) is the 'equation of the caloric line' and has essentially the same form as that derived by Schmidt. The maximum and minimum values of pressure are easily evaluated for the extreme values of $\cos \phi$:

$$p_{\max} = \frac{MR}{s(1 - b)} \quad (\text{A.1.10})$$

$$p_{\min} = \frac{MR}{s(1 + b)}. \quad (\text{A.1.11})$$

The average pressure over the cycle is given by

$$\begin{aligned} p_{\text{mean}} &= \frac{1}{2\pi} \int_0^{2\pi} p \, d\phi \\ &= \frac{MR}{2\pi s} \int_0^{2\pi} \frac{1}{(1 + b \cos \phi)} \, d\phi. \end{aligned} \quad (\text{A.1.12})$$

From tables of integrals (Dwight 1961), equation (A.1.12) reduces to

$$p_{\text{mean}} = MR / (s\sqrt{1 - b^2}). \quad (\text{A.1.13})$$

Equation (A.1.13) is the most convenient method of relating the total mass of working gas to the more conveniently specified mean operating pressure and is used for this purpose throughout this book.

Work is done by the engine on the surroundings by virtue of the varying volumes of the working spaces V_c and V_e . The total work done by the engine is therefore the algebraic sum of the work done by the compression and expansion spaces. Over a complete cycle we have

$$W_c = \oint p \, dV_c = \int_0^{2\pi} p \frac{dV_c}{d\theta} \, d\theta \quad (\text{A.1.14})$$

$$W_e = \oint p \, dV_e = \int_0^{2\pi} p \frac{dV_e}{d\theta} \, d\theta \quad (\text{A.1.15})$$

$$W = W_c + W_e. \quad (\text{A.1.16})$$

Differentiating equations (A.1.2) and (A.1.3), the volume derivatives are

$$\frac{dV_c}{d\theta} = -\frac{1}{2}V_{swc} \sin\theta \quad (\text{A.1.17})$$

$$\frac{dV_e}{d\theta} = -\frac{1}{2}V_{swe} \sin(\theta + \alpha). \quad (\text{A.1.18})$$

Substituting equations (A.1.17), (A.1.18) and (A.1.9) into equations (A.1.14) and (A.1.15), we obtain

$$W_c = -\frac{V_{swc}MR}{2s} \int_0^{2\pi} \frac{\sin\theta}{1+b\cos(\beta+\theta)} d\theta \quad (\text{A.1.19})$$

$$W_e = -\frac{V_{swe}MR}{2s} \int_0^{2\pi} \frac{\sin(\theta+\alpha)}{1+b\cos(\beta+\theta)} d\theta. \quad (\text{A.1.20})$$

The following approach to the solution of integrals (A. 1.19) and (A. 1.20) is somewhat different from that due to Schmidt. However, it is considered by the authors to be more easily comprehended.

The Fourier series expansion of the pressure function is first considered. It is shown that only one of the terms of this expansion will return a non-zero integral. This integral is then evaluated, giving the exact solution.

The Fourier series expansion of $p(\phi)$ in equation (A. 1.9) is given as follows (Arfken 1970):

$$p(\phi) = p_0 + \sum_{i=1}^{\infty} [p_{ci} \cos(i\phi) + p_{si} \sin(i\phi)] \quad (\text{A.1.21})$$

where

$$p_0 = \frac{1}{2\pi} \int_0^{2\pi} p(\phi) d\phi$$

$$p_{ci} = \frac{1}{\pi} \int_0^{2\pi} p(\phi) \cos(i\phi) d\phi$$

$$p_{si} = \frac{1}{\pi} \int_0^{2\pi} p(\phi) \sin(i\phi) d\phi.$$

Now, referring to the graph of equation (A.1.9) for a typical value of b (figure A. 1.3) we observe that $p(\phi)$ is an even function of ϕ and can thus be represented exclusively by the cosine terms. Equation (A. 1.21) thus reduces to

$$p(\phi) = p_0 + \sum_{i=1}^{\infty} p_{ci} \cos(i\phi). \quad (\text{A.1.22})$$

Substituting equations (A.1.22) and (A.1.17) into (A.1.14) we obtain

$$W_c = -\frac{V_{swc}}{2} \int_0^{2\pi} \left(p_0 + \sum_{i=1}^{\infty} p_{ci} \cos(i\phi) \right) \sin\theta d\theta. \quad (\text{A.1.23})$$

Expanding equation (A.1.23)

$$W_c = -\frac{V_{swc}p_0}{2} \int_0^{2\pi} \sin\theta d\theta - \frac{V_{swc}}{2} \sum_{i=2}^{\infty} p_{ci} \int_0^{2\pi} \cos[i(\theta+\beta)] \sin\theta d\theta - \frac{V_{swc}p_{c1}}{2} \int_0^{2\pi} \cos(\theta+\beta) \sin\theta d\theta. \quad (\text{A.1.24})$$

It can easily be shown that the first two terms on the right-hand side of equation (A.1.24) are zero, resulting in

$$W_c = -\frac{V_{swc}p_{c1}}{2} \int_0^{2\pi} \cos(\theta+\beta) \sin\theta d\theta. \quad (\text{A.1.25})$$

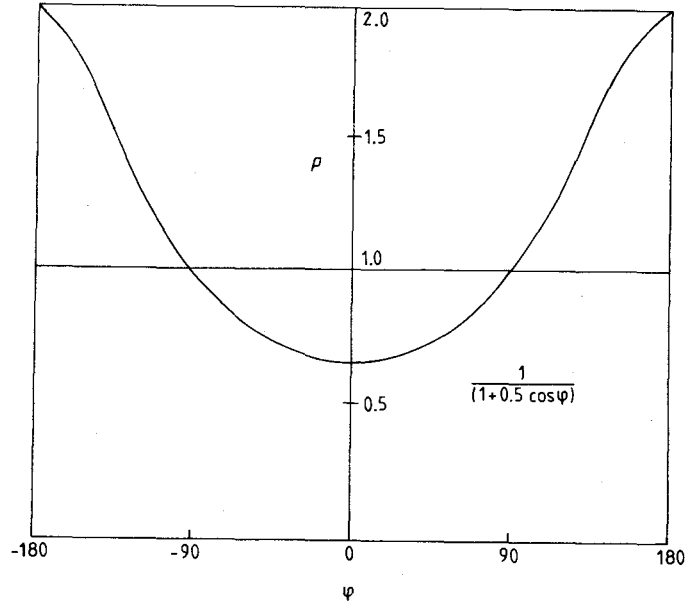

Figure A.1.3 Normalized pressure p versus composite angle θ .

Evaluating the integral of equation (A.1.25)

$$W_c = \frac{1}{2}\pi V_{swc} p_{c1} \sin \beta. \quad (\text{A.1.26})$$

Similarly, for the expansion space we find

$$W_e = \frac{1}{2}\pi V_{swc} p_{c1} \sin (\beta - \alpha). \quad (\text{A.1.27})$$

Now, from equations (A.1.21) and (A.1.9)

$$p_{c1} = \frac{MR}{\pi s} \int_0^{2\pi} \frac{\cos \phi}{(1 + b \cos \phi)} d\phi. \quad (\text{A.1.28})$$

Equation (A.1.28) can be evaluated in two steps using tables of integrals, as follows (Dwight 1961):

$$\begin{aligned} p_{c1} &= \frac{MR}{\pi s} \left(\frac{2\pi}{b} - \frac{1}{b} \int_0^{2\pi} \frac{1}{(1 + b \cos \phi)} d\phi \right) \\ &= \frac{MR}{\pi s} \left(\frac{2\pi}{b} - \frac{2\pi}{b\sqrt{1-b^2}} \right) \\ &= \frac{2MR}{sb} \left(1 - \frac{1}{\sqrt{1-b^2}} \right). \end{aligned} \quad (\text{A.1.29})$$

Substituting equations (A.1.29) and (A.1.13) into equations (A.1.26) and (A.1.27) we finally obtain

$$W_c = \pi V_{swc} p_{\text{mean}} \sin \beta (\sqrt{1-b^2} - 1)/b \quad (\text{A.1.30})$$

$$W_e = \pi V_{swc} p_{\text{mean}} \sin (\beta - \alpha) (\sqrt{1-b^2} - 1)/b. \quad (\text{A.1.31})$$

Equations (A.1.30) and (A.1.31) are essentially the same results as those obtained by Schmidt, and constitute the major analytical results of the analysis.

Now, since the Schmidt analysis is based on the Ideal Isothermal model, the thermal efficiency should reduce to the Carnot efficiency. The thermal efficiency is defined by the ratio of the work done by the engine to the heat supplied externally to the engine. In Chapter 2 we showed that the heat supplied externally is equal to the work done by the expansion space (equations (2.12) and (2.13)) thus:

$$\eta = W/W_c = (W_c + W_e)/W_c. \quad (\text{A.1.32})$$

Substituting equations (A.1.30) and (A.1.31) into equation (A.1.32)

$$\eta = 1 + \frac{V_{swc} \sin \beta}{V_{swc} \sin (\beta - \alpha)}. \quad (\text{A.1.33})$$

Expanding equation (A.1.33) and simplifying

$$\eta = 1 - \frac{V_{swc}}{V_{swc}} \left(\frac{\tan \beta}{\sin \alpha - \tan \beta \cos \alpha} \right). \quad (\text{A.1.34})$$

Substituting equation (A.1.7) into equation (A.1.34) and simplifying, we obtain

$$\eta = 1 - T_k/T_h \quad (\text{A.1.35})$$

which is the Carnot efficiency.

A.2 Regenerator mean effective temperature

In order to evaluate the total mass of gas in the regenerator void space correctly, the lengthwise distribution of the gas temperature must be known. It has been shown that for real regenerators, the temperature profile is very nearly linear (Urieli 1980), and thus we assume that the ideal regenerator has a linear temperature profile between the cold temperature T_k , and the hot temperature T_h , as in figure A.2.1 (Creswick 1965).

From figure A.2.1 we observe

$$T(x) = (T_h - T_k)x/L_r + T_k \quad (\text{A.2.1})$$

where L_r is the regenerator length.

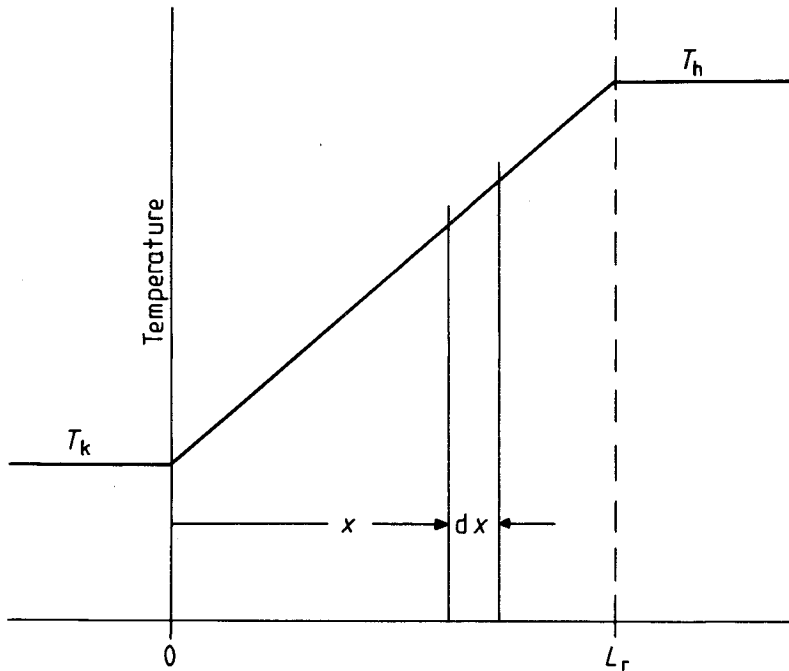

Figure A.2.1 Regenerator linear temperature profile.

The total mass of gas m , in the regenerator void volume is given by

$$m_r = \int_0^{V_r} \rho dV_r \quad (\text{A.2.2})$$

where ρ is the density, $dV_r = A dx$ is the lengthwise volume derivative for constant free-flow area A , and $V_r = ArL_r$.

Substituting for the ideal gas law $p = \rho RT$ in equation (A.2.2) and simplifying

$$m_r = \frac{V_r p}{R} \int_0^{L_r} \frac{1}{[(T_h - T_k)x + T_k L_r]} dx. \quad (\text{A.2.3})$$

Integrating the right-hand side of equation (A.2.3) and simplifying

$$m_r = \frac{V_r p \ln(T_h/T_k)}{R(T_h - T_k)}. \quad (\text{A.2.4})$$

We define the mean effective regenerator temperature T_r , in terms of the ideal gas equation of state:

$$m_r = V_r p / (R T_r). \quad (\text{A.2.5})$$

Comparing equations (A.2.4) and (A.2.5) we obtain

$$T_r = (T_h - T_k) / \ln(T_h/T_k). \quad (\text{A.2.6})$$

Equation (A.2.6) gives the mean effective regenerator temperature. T_r as a function of T_k and T_h , as required.

References

- Arfken G 1970 *Mathematical Methods for Physicists* 2nd edn (New York: Academic)
- Creswick F A 1965 Thermal design of Stirling cycle machines *Int. Auto. Eng. Congr. Detroit, SAE 650079*
- Dwight H B 1961 *Tables of integrals and other mathematical data* 4th edn (New York: Macmillan)
- Finkelstein T 1959 *Air Engines* in *The Engineer* part 1, 27 March
- Kolin 11972 The Evolution of the Heat Engine in *Thermodynamics Atlas 2* (London: Longman)
- Schmidt G 1871 The Theory of Lehmann's Calorimetric Machine *Z. ver. Dtsch. Ing.* 15 part I
- Urieli I 1980 A general purpose program for Stirling engine simulation *Proe. 15th IECEC, Seattle, Washington Paper 809336 pp 1701-5*



M100B FREE PISTON STIRLING COOLER

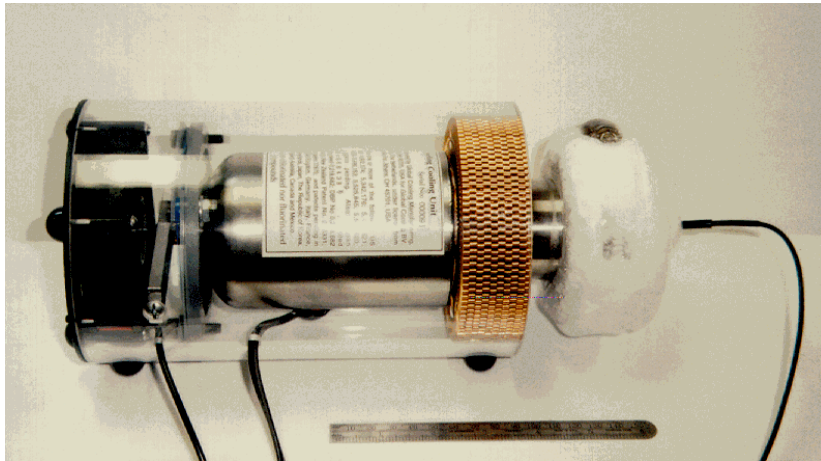

FEATURES

Fully Modulatable Cooling Unit

Long Life

Low mass: 2.25 kg

Low noise, vibration balanced operation

DC, solar and AC versions

High efficiency maintained across load spectrum

Maximum capacity 100W @ 0 degrees C

Modular self-contained cooling system

Maintains performance under high ambient temperatures

Earth safe no chlorinated or fluorinated compounds

PERFORMANCE MAP

Amplitude is roughly proportional to the voltage. The controller automatically adjusts the drive voltage in response to the closeness of approach to the set point temperature.

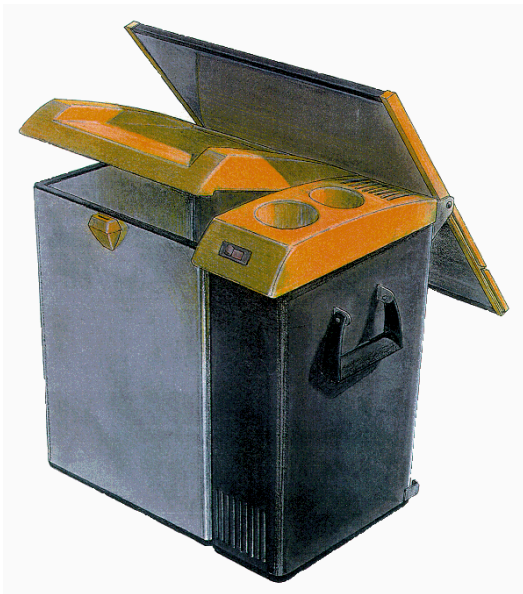
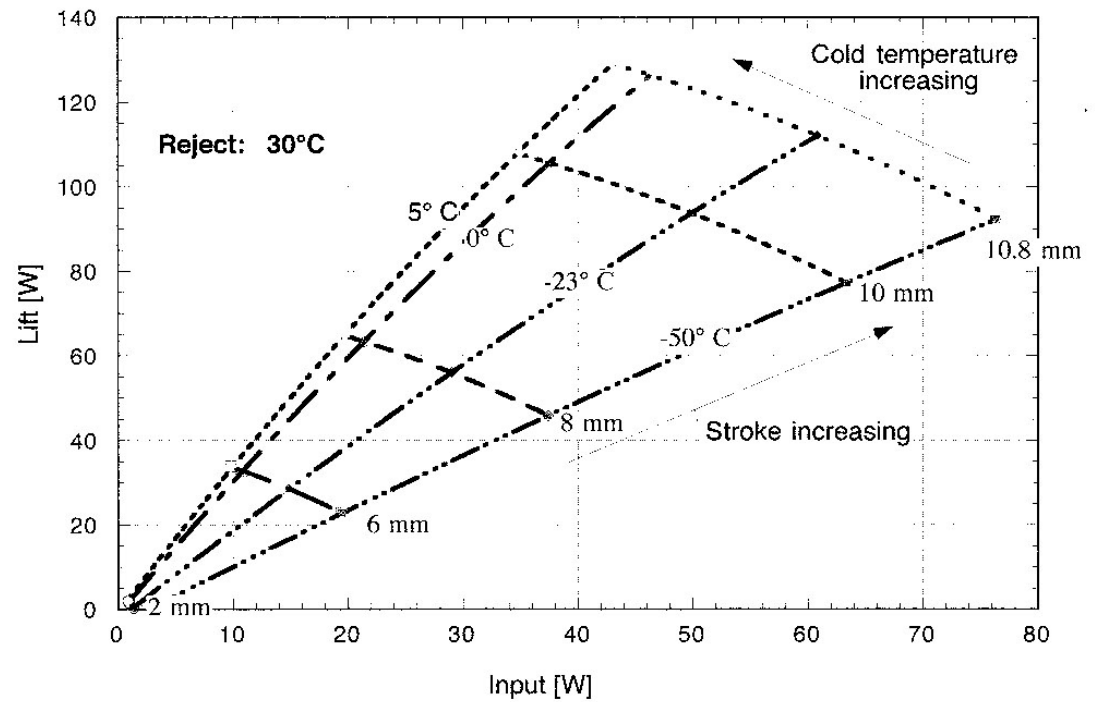

APPLICATIONS

Minibars

Small domestic refrigerators

Vaccine storage

Recreational vehicles

Portable refrigerators

Ice cream makers

Low temperature food storage [below -50° C]

Ideal for solar powered cooling applications

changing the way the world cools...

M100A Free Piston Stirling Cooler

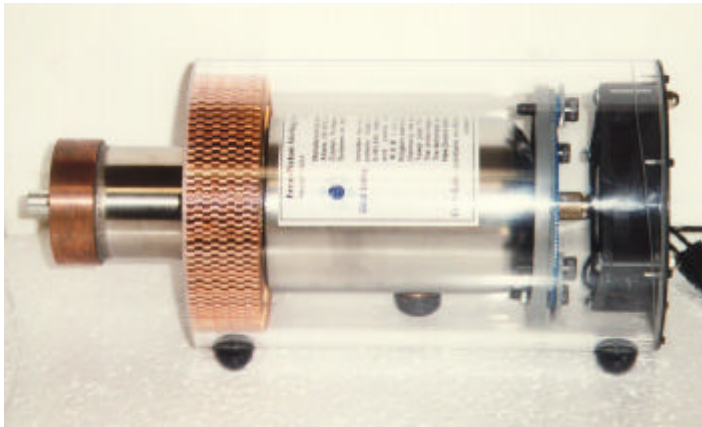

Fully Modulatable Cooling Unit

- Long Life
- Low mass 2.25 kg
- Low noise, vibration balanced operation
- DC, solar or AC versions
- High efficiency maintained across load spectrum
- Maximum capacity 100W
- Modular self-contained cooling system
- Maintains performance under high ambient temperatures
- Earth safe no chlorinated or fluorinated compounds



Applications

- Minibars
- Small domestic refrigerators
- Vaccine storage
- Recreational vehicles
- Portable refrigerators
- Ice cream makers
- Low temperature food storage [below -50° C]
- Ideal for solar powered cooling applications

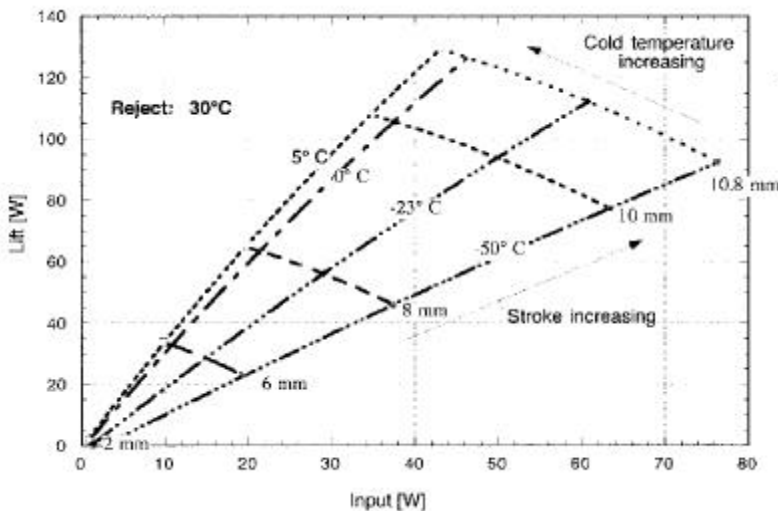

Performance Map

- Amplitude is roughly proportional to voltage
- The controller automatically adjusts the drive voltage in response to the closeness of approach to the set point temperature.

HOME TECHNOLOGY

EDITED BY JUDITH ANNE GUNTHER

APPLIANCES

Independent Fridges

KEEPING FOOD COLD in a hot climate is a tough trick if you don't have electrical power. But a new device based on an old principle may bring the benefits of refrigeration to people in regions where electricity is either unavailable or unreliable.

Global Cooling BV of the Netherlands and Athens, Ohio, is producing small quantities of a solar-powered refrigerator for field testing. The refrigerator uses photovoltaic panels to turn sunlight into electricity. It then consumes this power efficiently, thanks to super-insulating vacuum panels and a Stirling cycle cooler developed by Sunpower Inc., of Athens, Ohio. On average, the seven-cubic-foot refrigerator operates on eight watts. (A typical 18-cubic-foot American refrigerator, including a freezer compartment, consumes about 70 watts.) The refrigerator stores cooling capacity by making ice, for cloudy days.

Though the Stirling cycle was invented in 1816, Sunpower has spent more than 20 years developing the

concept for applications such as cryogenic freezers and a cooler used aboard NASA's space shuttle Discovery. Most refrigerators in use today remove heat from the food compartment by alternately compressing and expanding a refrigerant, enabling the substance to absorb heat in its gas phase and reject heat in its liquid phase. By contrast, the Stirling cooler shuttles a confined volume of helium gas back and forth between the cold and warm ends of the unit, with no phase change. The gas expands at the cold end to absorb heat and is compressed at the warm end by a piston to reject heat.

Instead of a conventional compressor, which uses a crankshaft to convert rotary motion into linear motion, Sunpower's Stirling cooler uses a low-friction electromagnetic coil and spring, used to drive the piston's reciprocating motion. This scheme makes the device not only highly efficient, but quiet, too.

Global Cooling won't announce the production timetable until more testing has been completed. The fridges might be marketed in industrialized countries in addition to developing nations.—Richard Babyak

A Stirling cooler helps a solar fridge operate efficiently.

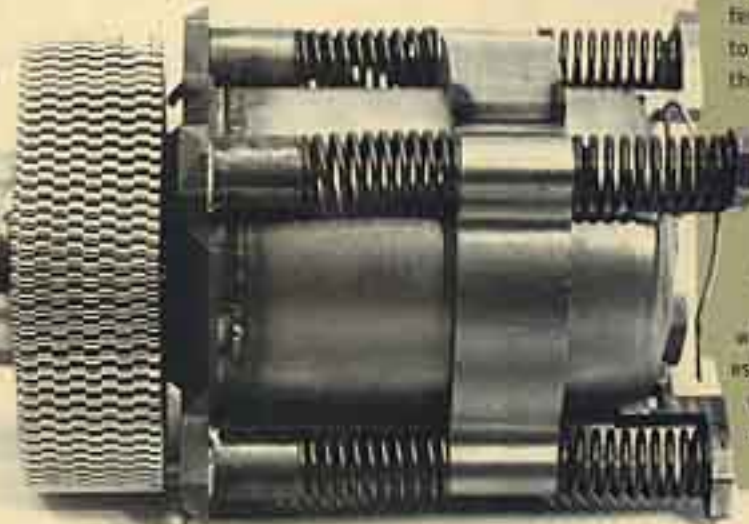

LIGHTING

Blinded by the Light

WINDOW blinds have always been an effective and convenient way to control the amount of sunlight coming into a room. But wouldn't it be nice if instead of merely blocking unwanted light, window blinds could also capture and store light for use at night?

The Solar Blind turns night into day, using integrated photovoltaic film and electroluminescence.



The Solar Blind would do just that. Each horizontal slat has a thin, flexible photovoltaic film on its rear edge that converts sunlight into electricity and stores it in a rechargeable battery. At night, flat electroluminescent strips on the front edge of the slats glow softly, providing the room with background ambient lighting. According to Solar Blind's inventors, the light from a 3-by-6-foot blind with 14 slats would be roughly equivalent to two 20-watt incandescent bulbs.

For creating different types of ambience, the electroluminescent light source could be tuned to different colors, ranging from pure red to white. When exposed to full sun, the Solar Blind could generate about 49 watts of electricity.

Although its primary function is for lighting, the stored electricity could also be used to power other appliances, such as ventilation fans.

New York City's Ecco Design, which developed the Solar Blind, estimates that the production cost will be roughly \$400 to \$500 for a 3-by-6-foot blind.—Ned Nisson

fcfCf“fo•[fh•H<ÆŠ”Ž®%oiŽĐ

[fcfCf\fbfv](#)

- ,g,n,l,d HOME
- •i•î•ñ 商品情報
- ;-â,c•î•í,•EjTf•[fgト
- @•l,Î•î,Ö 法人の方へ
- %oiŽĐ•i 会社情報

[English Home](#)

[Japanese Here](#)

06/06/2002

Twinbird Corporation develops a practical "New Cooling System using Natural Refrigerant (Helium Gas)"

Twinbird Corporation (Mr. Shigekatsu Nomizu, President and Chief Executive Officer, Head quartered in Niigata Prefecture Japan) has successfully developed a compact FPSC (Free Piston Stirling Cooler) after the technical introduction and collaboration with Global Cooling BV (Arnhem, The Netherlands, Research Center in Athens Ohio, USA; Principal Dr. David Berchowitz). Having maintained quality and reliability, further work is underway and concentrated on manufacturing and processing technology.

● Outline of the Product

Twinbird Corporation are in the final stage of the development work on the Free Piston Stirling Cooler "FPSC-TB40" and expects to have market ready products in Fiscal Year 2003. The TB40 has significant differences to the conventional Rankine compressor or Peltier (thermoelectric) module type refrigeration systems. It is a new type of refrigeration system that uses neither ozone depleting nor global warming gas and no lubrication oil. The cooling technique is based on the Stirling cycle for maximum efficiency. Aside from being environmentally friendly, the unit is also compact, light weight and may be operated on many different power sources such as AC or DC electricity and photovoltaics (solar battery).

Main Features

- 1) Rapid Cooling to deep temperature
- 2) Precise Temperature Control (+/-1°C)
- 3) Compact and Lightweight
- 4) Energy Saving
- 5) Environmentally friendly

It is possible to achieve -20° (-4°F) in a small sized freezer with one FPSC whereas it may be difficult to reach such temperatures with conventional Rankine compressors. Under no-load conditions -50°C (-58°F) can be obtained in about 2 minutes at an ambient temperature of 25°C(77°F).

The casing construction is of stainless steel and the unit may be easily hand-carried.

The working gas is the natural occurring helium. No Chlorofluorocarbons (CFCs) nor Hydro fluorocarbons (HFCs) are used and furthermore no oil nor grease are required.

CFCs have been associated with ozone depletion and global warming.

The TB40 has a maximum lift of 40W and a Coefficient of Performance (COP) of about 1.2 at -23.3°C(-9.9°F) on cold side and 35.0°C(95.0°F) on warm side.



Major Specification (data on the trial samples)

	Item	Specification
1	Cooling system	Free piston Stirling cooler
2	Refrigerant	Helium gas
3	Capacity	40W at -23.3°C Cold side , +35°C warm side
4	COP	1.2
5	Power supply	DC12V, 3A
6	Dimension	86mm diameter, 245mm length
7	Weight	1.6Kg
8	Ambient temperature	0°C - 50°C

Comparison table of cooling systems (on Twinbird product)

System	FPSC	Compressor	Thermoelectric
Power Consumption	40W	40W	60W
COP*	1.2	1.2	0.2
Lowest temperature	-50°C	-20°C	-5°C
Availability of cool and warm	No	No	Yes
Freezing	Yes	Yes	Not good
Solar battery operation	Yes	Not good	Fair
Size	Good	Not good	Fair

Weight	Good	Not good	Fair
Influence to environment	Good	Fair	Not good**

* At rated refrigeration condition in ambient temperature 25°C.

** Uses a lot of energy and is therefore poor from a global warming view point.

The Background of FPSC Research and Development:

We, at Twinbird Corporation, developed and marketed the various thermo-electric module (Peltier) type hot/cool boxes for such as outdoor, automobile and personal, for the first time in 1989 and have since sold large numbers of these products. During this period we concentrated on research and development of refrigeration technology with Peltier and others, and introduced novel design concepts. Simultaneously the requirement and needs for global environment conservation and energy saving were raised and we have been extended our efforts to meet and satisfy these requests of our customers.

Given these circumstances, we have been engaged in refrigeration technology as one of our core technologies and in particular decided to introduce Global Cooling's FPSC environmentally friendly and higher efficiency technology for our next generation refrigeration systems.

The development of mass production FPSC refrigeration systems enable us to meet the following market demands and needs that was difficult to obtain with the thermo- electric (Peltier) and compressor type refrigeration systems;

- 1) To cool faster
- 2) To cool to deeper temperatures.
- 3) Compact and smaller sized.
- 4) No chlorofluorocarbon (CFC) nor hydrofluorocarbon (HFC) gas and no lubrication oil/grease.
- 5) High efficiency and energy saving

The FPSC is environmentally friendly and energy saving, and offers new product opportunities. For example, we are able to anticipate a dry-ice type freezer / refrigerator using this device.

The Current Status of FPSC Engineering Development:

We have organized the Core Technology Laboratory (CTL) and started the development project of the FPSC in 1998. This effort has since been promoted to our new and core business unit. Utilizing our know how technology of thermo-electric refrigeration, joint research and study with university institutions, and concentrating local associates in precision technologies of stainless steel processing (and other materials), we have completed a number of sample units of FPSC-TB40.

From now on, we will be concentrating our development work on mass production engineering development aiming at cost equivalence to the Rankine compressor. We will work to expand the line-up beside the TB40 and add these new models to our business operations in the near future.

The Application of FPSC:

Our FPSC-TB40 can be operated by various energy sources such as AC electricity, DC car battery, photovoltaic (solar battery) or in-house generators etc.

FPSC-TB40 can start operation with smaller voltage than DC 12V electricity because it is operated in resonance by an electronically controlled linear motor. The FPSC is most suitable to apply to small counter top freezers / refrigerators, cooler boxes for outdoor use and car use. The portable domestic refrigerators and refrigeration systems for use in remote areas where no electricity is available become practical with this technology.

The biggest advantageous characteristics of FPSCs is the use of naturally occurring Helium gas and the hermetically sealed stainless casing (sealed type refrigeration system) that makes easier for designing the integration of FPSC to the various products. Additionally FPSCs can be user set to a precise temperature within a wider range such as zero degree refrigeration or minus 30°C(minus 22°F) freezer conditions because it operates on a continuous modulation principle.

In the first year of the production, we intend to integrate the FPSC into small freezer / refrigerators and commercial applications such as small water coolers. As we approach the mass production stage in the following year, we shall start applying the technology to automotive cooler boxes, small outdoor leisure refrigerators and other consumer appliances in order to develop the market. We will introduce a wide range of products that can be developed with this next generation refrigeration technology featuring compactness, lightweight and environmentally friendly characteristics.

For Inquiry, please contact to; e-mail : sc@twinbird.co.jp,
Mr. H. Fujino or Mr. K. Sone,
SC Business Development Operations, Twinbird Corporation

[☒•l•î•ñ, ìžæ^μ, ç, É, Â, ç, Ä☒fcfg, Ì, ²—~—p, É, , ½, Á, Ä](#)

[ΔPage Top](#)

Copyright(C) 2007 TWINBIRD CORPORATION, All Rights Reserved.



"Changing the Way the World Cools"

- Home
- About GC
- GC Japan
- Stirling History
- Stirling Links
- Contact Us

what we do

Our Services - Heating

Hot Water

FPSC Technology up to 1 KW- [Contact Global Cooling](#)

- High Temperature heat Pump
- Low or High Ambient Ops
- Compact
- Modulating
- Earth Friendly
- Efficiency

FPSHP - Free Piston Stirling Heat Pump

FPSC - Free Piston Stirling Cooler

OCC - Oscillating Crank Compressor

EEV - Electronic Expansion Valve

- Tech Overview
-
- How it Works
- Products
- Tech Papers
- Licensing

Home Heating and Cooling- [Contact Global Cooling](#)

FPSPH Technology up to 20 KW (in development)

- Low operating costs
- Compact
- Modulating
- Earth Friendly
- Efficiency

Commercial Buildings

Global Cooling Not Involved - [Contact Sunpower](#)



"Changing the Way the World Cools"

- Home
- About GC
- GC Japan
- Stirling History
- Stirling Links
- Contact Us

- Tech Overview
-
- How it Works
- Products
- Tech Papers
- Licensing

what we do

Our ServiceS - cooling

Home Cooling A/C

FPSHP Technology up to 20 KW (In development) - [Contact Global Cooling](#)

- Low operating costs
- Compact
- Modulating
- Earth Friendly
- Efficiency

Electronics cooling

Technologies include Computer Applications, Sensor Applications, Spot Cooling, RF, Power Electronics, etc.

FPSC Technology up to 1 KW - [Contact Global Cooling](#)

- Deep temperatures
- High Ambient Ops
- Compact
- Modulating
- Earth Friendly
- Efficiency

Refrigeration

Domestic (Home)

FPSC Technology up to 300 W - [Contact Global Cooling](#)

- Compact
- Modulating
- Earth friendly
- Efficient

Rankine (Compressors) - [Contact Global Cooling](#)

EEV - Any Reciprocating Compressor

- Pull Down Speed
- Energy Saving
- Smaller Compressor

Oscillating Crank Compressor (OCC) Technology (In development) - [Contact Global Cooling](#)

Energy Saving

Commercial

FPSC Technology up to 1 KW - [Contact Global Cooling](#)

- Deep temperatures

FPSHP - Free Piston

Stirling Heat Pump

FPSC - Free Piston

Stirling Cooler

OCC - Oscillating Crank

Compressor

EEV - Electronic Expansion

Valve

- High Ambient Ops
- Compact
- Modulating
- Earth Friendly
- Efficiency

Rankine (Compressors) - [Contact Global Cooling](#)

EEV - Any Reciprocating Compressor

- Pull Down Speed
- Energy Saving
- Smaller Compressor

OCC Technology (In development) - [Contact Global Cooling](#)

Energy Saving

Portable

FPSC Technology up to 50 W

Instrumentation/Others

FPSC Technology up to 10 KW - [Contact Global Cooling](#)

- Deep temperatures
- High Ambient Ops
- Compact
- Modulating
- Earth Friendly
- Efficiency

Cryo Cooling

Tempertures below 150K - [Contact Sunpower](#)



"Changing the Way the World Cools"

- Home

- About GC

- GC Japan

- Stirling History

- Stirling Links

- Contact Us

what we do

Our Services

We do not handle "Power" applications. - [Contact Sunpower](#)

- Tech Overview

-

- How it Works

- Products

- Tech Papers

- Licensing



"Changing the Way the World Cools"



welcome to the homepage of Global Cooling!

[Global Cooling](#) develops innovative refrigeration solutions. For example, the [Free-Piston Stirling Cooler](#) developed by Global Cooling has a high energy efficiency and uses earth friendly cooling substances. If you feel your refrigeration products are in need of major innovation, please [contact us](#). Together we can change the way the world cools!



did you know...

John Ericsson, the inventor of marine screw propellers and gun turreted warships and the designer of the famous civil war era Monitor was also the inventor of the high performance wire mesh regenerator used in modern Stirling engines and cooling machines. Indeed, the largest Stirling engine ever constructed was designed by Ericsson for use in the ship of the same name Ericsson. Even more amazing is that he constructed the first solar driven Stirling engine using a parabolic reflector in

Latest Updates!!

October 21, 2008

Global Cooling's newest portable freezer, the SC-UL25, is scheduled for public release in late Q4 2008. The new freezer will be capable of reaching temperatures below -95°C while drawing power from an automobile 12VDC cigarette lighter. Maximum power consumption is typically around 150-180Watts (comparable to headlights). The unit



[Global Cooling M100/150 FPSC](#)

currently weighs in at less than 35lbs and has a cargo capacity of just under 1cu.ft..This revolutionary new product allows for unprecedented new capability in the Ultra-Low Temperature Transport and Storage industries and will be the first in a complete line of FPSC based ULT freezers scheduled to be released over the next 24-36 months.



about 1870.

March 3, 2008

[Twinbird FPSC/Module](#)

The latest version of Global Cooling's revolutionary new Ultra-Low temperature Freezer, The SC-UL25, was unveiled at the Pittcon 2008 show in New Orleans. The newest version has been upgraded with VIP insulation and an increased cargo volume. Now a 25L (0.9 cu ft) capacity with a low temperature capability of -92 degrees C vs. the original SC-UL20's 20L (0.7 cu ft) and -80 deg C capability and expanded foam insulation. This enhancement was accomplished without changing the exterior envelope or system mass. The current beta prototypes are undergoing final modifications and testing with product launch scheduled for Q4 2008. The new SC-UL25 provides precision temperature control, programmable rate cooling and an integrated heating element to provide not only the Worlds first truly portable Ultra-Low temperature freezer but also the Worlds first truly portable environment chamber capable of temperatures ranging from -92 deg. C to 110 deg C. The SC-UL25 requires only 12V DC 12.5A input power and uses less than 150W of power to maintain an internal temperature of -80 deg C in a 25 deg C environment. In fact, the new SC-UL25 can be powered by most standard cigarette lighter/ Accessory ports available in modern automobiles. This puts the total power consumption of the SC-UL25 at an order of magnitude below the typical power consumption of small - 80 deg C class freezers!



[Portable High Performance Refrigerator/Freezers/ ULT Freezers](#)

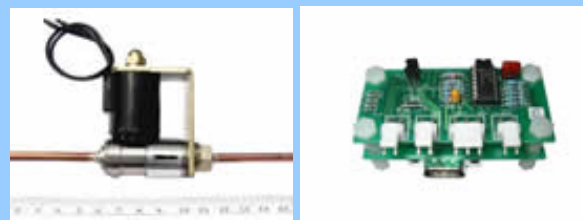

[Global Cooling Electronic Expansion Valve](#)

[Archive](#)

©2004 - 2008 Global Cooling - 141 North Columbus Road - Athens, Ohio 45701 USA - (740) 592-2655 - info@globalcooling.com



"Changing the Way the World Cools"

- [Home](#)

- [GC Japan](#)

- [Stirling History](#)

- [Stirling Links](#)

- [Contact Us](#)



About Global Gooling

- [Tech Overview](#)

141 Columbus Rd
Athens, Oh 45701
(740) 592-2655
(740) 592-2695 fax

- [What We Do](#)

- [How it Works](#)

- [Products](#)

- [Tech Papers](#)

- [Licensing](#)

Innovators in Energy Conservation

Global Cooling Inc. is a Delaware USA, based corporation with two, wholly owned subsidiaries; Global Cooling BV and Global Cooling Manufacturing. Global Cooling BV, with headquarters in The Netherlands, was brought into existence in 1994 when it purchased a license for free-piston Stirling refrigeration technology developed by Sunpower of Athens, Ohio. Global Cooling Manufacturing Co., with headquarters in Athens, Ohio, was established in 1995 for the purpose of developing and producing Stirling Coolers for commercial and consumer applications.



Global Cooling - The Netherlands

ROBLEM TO BE SOLVED

Stirling coolers will dramatically reduce the energy consumption and environmental impact of refrigeration. Despite the expectations and promises of current refrigerants, particularly the hydrofluorocarbons (HFC's) like R134a, it has been demonstrated that these refrigerants still have a detrimental affect on the environment. The Free Piston Stirling Cooler (FPSC) technology incorporated into products by Global Cooling and its licensees uses only natural working fluids (helium) and operates at high efficiencies, providing a fundamental advantage over competing systems.

THE GLOBAL COOLING ANSWER

Global Cooling's free-piston Stirling has several unique benefits over conventional refrigeration systems. While current domestic refrigerators have a Rankine-cycle cooling system, driven by a motor-compressor, in a Stirling refrigerator this system would be replaced by a Stirling-cycle cooling system. Rankine systems show a characteristic decrease in efficiency as the demand for cooling decreases, e.g. when the refrigerator is maintaining a cold condition. However, Free Piston Stirling Coolers (FPSC's) retain their high efficiency regardless of the demand for cooling because they can fully modulate their capacity to match the required



Self Contained Low Temperature
Petroleum Analyzer

load. In addition, the FPSC system requires no environmentally damaging CFC's, HCFC's, HFC's, or dangerous hydrocarbons (butane, for example). Operationally, the FPSC is able to work efficiently at far higher and far lower temperatures than conventional equipment, making it ideal for new or otherwise impractical cooling and heat transport problems.

eNERGY/ENVIRONMENTAL/ECONOMIC BENEFITS

Global Cooling's FPSC, with its ability to fully modulate cooling capacity to match demand, is much more energy efficient than conventional Rankine systems which can only turn on and off. GCBV submitted a design for a portable refrigerator to the judging committee of the Maltha Environmental Award in 1995 and was awarded First Prize. Today this concept has been commercialized in the form of a 25 liter consumer portable refrigerator/freezer manufactured by Twinbird Corporation of Japan.

NATIONAL/INTERNATIONAL IMPACTS:



25L Twinbird FPSC Portable refrigerator/Freezer

Global Cooling intends to commercialize its Stirling cooler globally by licensing the technology to major appliance manufacturers on a world wide basis. A number of major appliance manufacturers are currently sponsoring development work at Global Cooling. Several Global Cooling Stirling coolers are being tested at independent laboratories around the world.



"Changing the Way the World Cools"

- Home
- About GC
- GC Japan
- Stirling History
- Stirling Links
- Contact Us

- Tech Overview
-
- How it Works
- Products
- Tech Papers
- Licensing

what we do

Our Services - decision tree

We develop innovative refrigeration solutions. For example, the Free-Piston Stirling Cooler (FPSC) developed by Global Cooling has a high energy efficiency and uses earth friendly cooling substances. If you feel your refrigeration products are in need of major innovation, please contact us. Together we can change the way the world cools!

A Free Piston Stirling Cooler (FPSC) is a single phase cooling device that moves heat from a cool source to a warm sink with the help of external heat exchangers. Applications of FPSCs range from exotic deep temperature units to machines that perform well in domestic applications, such as home refrigerators.

A FPSC differs from a compressor system in that the refrigerant is not pumped into the space that is to be cooled. Rather, a Stirling cooler has a cold head, where heat is transferred into the machine, and a warm head, where heat is transferred out of the machine. External heat exchangers are used to transfer heat from the refrigerated space to the Stirling and are simply clamped onto the appropriate head. External heat exchangers are customized for the specific needs of each application, but typically come in the form of a thermosyphon, pumped fluid loop, or forced air and fin system.

Global Cooling's Free Piston Stirling Cooler (FPSC) technology is currently available in 40, 60, 100 and 150 Watt capacities. Soon, new FPSC coolers will become available in capacities up to 600 Watts. The chart below outlines some of the current and soon to be released FPSC performance data.

Model *under development	Cooling Capacity (W)	Temperature Range (°C)	COP
TB40	40	-110 to +65	1.2
TB80	>60	-110 to +65	1.2
TB150	120	-120 to +65	1.2
M100	120	-140 to +65	≈2
M150	150	-140 to +65	≈2
*M600	600	-170 to +65	≈2
*ST500	>120	280+ ambient	1.5+
*P500	>120	280+ ambient	1.5+
*G600	>550	80+ ambient	1.2+

We have created this decision tree to help you determine whether we provide the services that you desire.

Please Choose:

- [Energy Conversion](#)
- [Heat Transfer](#)

©2004 - 2008 Global Cooling - 141 North Columbus Road - Athens, Ohio 45701 USA - (740) 592-2655 - info@globalcooling.com



"Changing the Way the World Cools"

technology overview

Stirling coolers

- Home

- About GC

- GC Japan

- Stirling History

- Stirling Links

- Contact Us

- What We Do

- How it Works

- Products

- Tech Papers

- Licensing

What is a Stirling cooler?



A Free Piston Stirling Cooler (FPSC) is a single phase cooling device that moves heat from a cool source to a warm sink with the help of external heat exchangers. Applications of FPSCs range from exotic deep temperature units to machines that perform well in domestic applications, such as home refrigerators.

A FPSC differs from a compressor system in that the refrigerant is not pumped into the space that is to be cooled. Rather, a Stirling cooler has a cold head, where heat is transferred into the machine, and a warm head, where heat is transferred out of the machine. External heat exchangers are used to transfer heat from the refrigerated space to the Stirling and are simply clamped onto the appropriate head. External heat exchangers are customized for the specific needs of each application, but typically come in the form of a thermosyphon, pumped fluid loop, or forced air and fin system.

What are the advantages of FPSCs?

1. [Extremely long life is reached through the use of non-contact running surfaces.](#) **Gas bearings** allow the two moving parts to "ride on a cushion of air" keeping the running surfaces from making contact while the machine is operating.
2. [High efficiency over a wide refrigerated and ambient temperature range.](#) Unlike vapor compression systems outfitted with capillary tubes that have optimized performance at only one temperature condition, Stirling coolers maintain their high performance over a wide range of temperature conditions.
3. [No CFC or other environmentally dubious chemicals.](#) Global Cooling uses the environmentally safe, inert gas helium as the working fluid in their Stirling coolers.
4. [Light weight machines.](#) Light weight makes portable cooling a reality.
5. Infinitely variable lift leads to no "on/off" losses. The Stirling cooler can be modulated to provide cooling between 0% and 100% of the capacity. Modulating the cooler allows for precision cooling of the refrigerated space and removes the losses associated with "on/off" controlling, an energy saving or extension of battery life of approximately 20%. The coolers also have very low start current, being able to start with just a minimum input. No need for starting capacitors or expensive electronics.
6. Operation at high ambient temperatures. Stirling coolers perform well in harsh temperature environments, high ambient temperatures are limited only by the materials of the cooler.

Gas Bearing Technology

The Stirling coolers designed at Global Cooling utilize oil-free lubrication by the way of gas bearings. Gas bearings work by charging an internal volume in the piston during the compression stroke and then leaking the trapped gas out into the space between the piston and the cylinder wall. This produces a layer of high pressure gas between the two running surfaces that levitates the piston allowing the piston and cylinder to operate in a non-contact way. As long as the gas bearings are working properly and the machine is running, the moving parts will never make contact and last for an extremely long time.

Light Weight Coolers

Stirling coolers excel in small capacity cooling and have light weight making it the perfect solution for portable cooling. A 40 Watt Stirling cooler weighs 1.6 kg where a similarly sized compressor weighs 4.3 kg. A plot of the mass vs. capacity for both compressors and Stirling machines is shown below. There are two Stirling trend lines, the solid line indicates the mass and capacity of prototype or limited production machines today, where the dashed line represents the projected performance and mass after becoming fully commercialized.

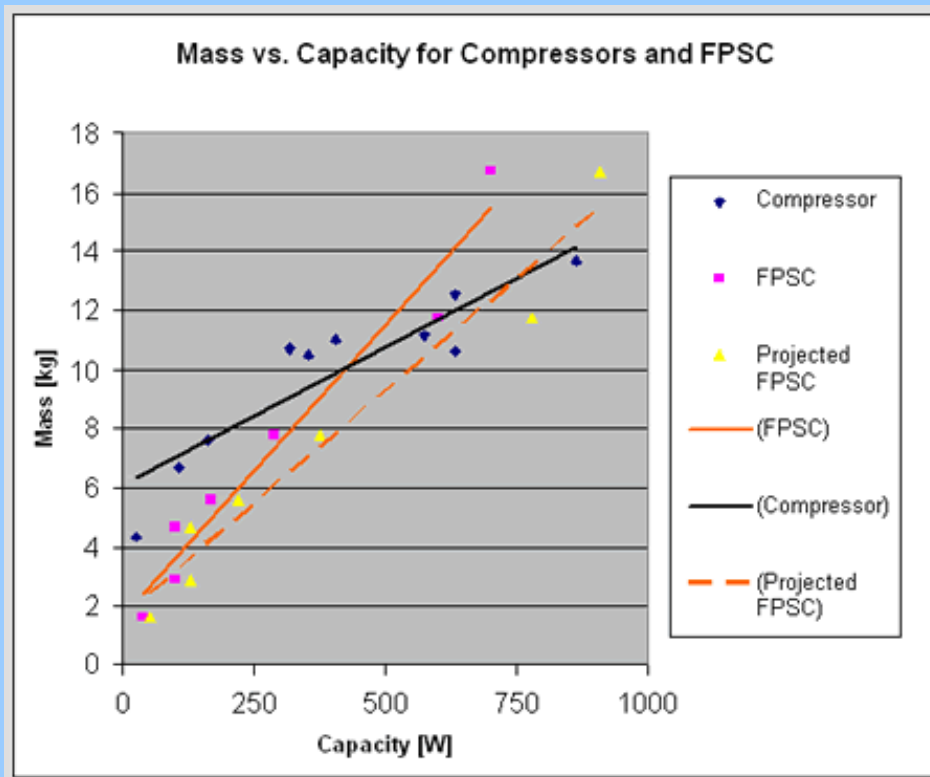

Performance Map of Stirling Cooler

Stirling coolers have high performance over a wide temperature range, making them ideally suited for applications with varying ambient or refrigerated space temperatures, such as outdoor vending machines or portable cool boxes. A performance map is shown below for the M100A optimized for near room temperature use.

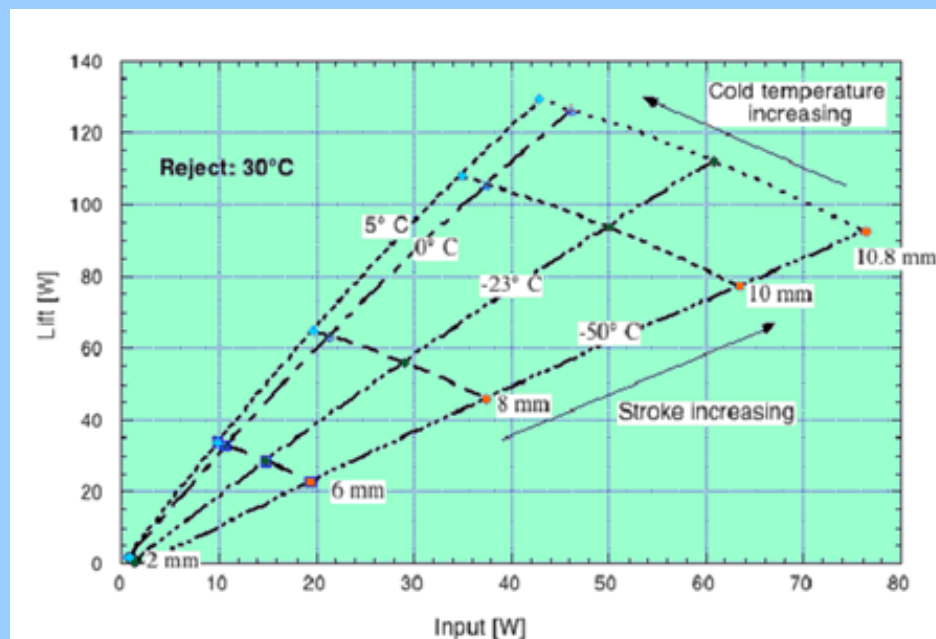

Figure 1: Performance map of M100A with a fixed reject temperature of 30°C and a cold head temperature range between 5°C and -50°C.

Environmentally Responsible Cooling

Currently, the majority of the world's cooling needs are being met by a vapor compression cycle that uses a compressor to circulate an artificial (typically) working fluid. These artificial working fluids, called refrigerants, typically hydro-fluorocarbons (HFCs) or hydro-chlorofluorocarbons (HCFCs such as R22), have been proven to have excellent thermal properties, remain stable when properly bottled, and are inexpensive to manufacture. Unfortunately, they are also harmful to the global environment by being major contributors to the depletion of the ozone layer and contributors to the global warming phenomena.

In 1987, negotiators ratified the Montreal Protocol to create binding commitments to reduce the manufacture and use of environmentally dubious chemicals harmful to the ozone layer. As of 2002, 183 countries have pledged to phase out the use of ozone depleting substances, including chlorofluorocarbons (CFCs), and hydro-chlorofluorocarbons (HCFCs). Developed countries that signed the Montreal Protocol fully phased out CFCs in 1996, and instituted a production freeze on HCFCs in 1996. By 2010, all CFC's and the majority of HCFCs will no longer be in use.

Replacements for the phased out refrigerants have been developed; hydro-fluorocarbons (HFCs such as R-134a), and hydro-carbons (HCs such as butane) are the current options for refrigerants, however, both have their downfalls. HFCs do not have an ozone depleting nature, but do contribute to the global warming problem. Researchers have shown that once released into the environment, the most common HFC, R-134a, will contribute to the global warming problem for up to 100 years before it is finally broken down. HFs such as butane have the down fall of being explosive, causing a serious risk when used in indoor applications.

Refrigerant	Ozone Depletion	Global Warming	Safe
CFC	Very High	Very High	Y
HCFC	Very High	Very High	Y
HFC	Zero	High	Y
HF	Zero	Zero	N

Figure 1: Chart of the environmental impact of different refrigerants.

Stirling coolers are a technology available today that has zero effect on the ozone layer, does not directly contribute to global warming, and does not use a flammable gas. Stirling coolers are able to avoid all of the down falls of the chemicals used in vapor compression cycle by using Helium as the working fluid. Helium has the advantage of being a natural, non-flammable, inert gas that is not reactive to the world around it.



"Changing the Way the World Cools"

- Home

- About GC

- GC Japan

- Stirling History

- Stirling Links

- Contact Us

- Tech Overview

- What We Do

- How it Works

- Tech Papers

- Licensing

[GC Distributed Twinbird Products:](#) [Global Cooling FPSC products:](#)

GCM products:

M-100 Free Piston Stirling Cooler (FPSC)

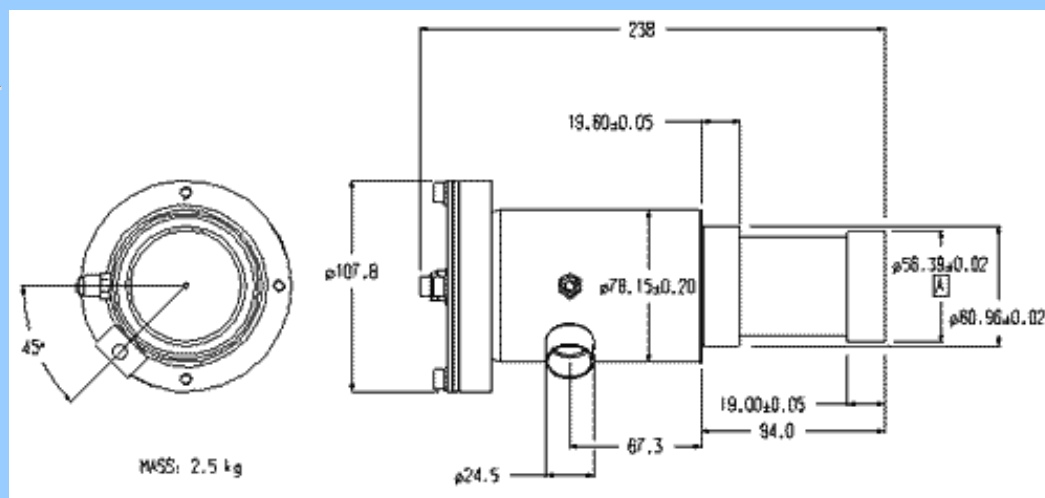

M100B Exterior Dimensions [mm]

The M100B Free Piston Stirling Cooler (FPSC) is among the first Stirling coolers to be introduced to the market. The first production run of this unit allowed Global Cooling (GC) to introduce its technology to a number of manufacturers working in industries from food refrigeration to laser cooling. Not only did the first production runs allow GC to sell demonstrators to interested parties, it also gave GC a chance to field test units in a number of different environments. The feedback and reliability information that we received from these first units allowed us to continually improve the product as development progressed.



We are also involved with other manufacturers to develop models of different capacities and of lower cost. Some of these are already available while others are projected to be available to the public in one year. For information on the progress of these programs check this web site since it will be kept up to date.

To investigate the possibilities of using Stirling Coolers in your application you can find detailed information throughout this web site. Check the [Technical Papers](#) page for papers on the subject.

- [M100B HTML Brochure](#)
- [M100B PDF Brochure](#)
- [Popular Science Article](#)

EcoValve Electronic Expansion Valve (EEV)



Eco Valve - EEV Technology

Unique capabilities:

- Control of refrigerant flow down to exceptionally low rates of 15 W or less of refrigeration. A range of presently available orifice diameters enables flow control to 1200 W refrigeration, and higher flow rates are possible with a larger valve body.
- Maintains stable superheat of 3°C, even at low flow rates.
- Physically small and easy to install by brazing into the liquid line at the evaporator inlet. The control unit is small, easily installed, and uses only 0.5W average power.
- Works with all common refrigerants, e.g., R134a, R22, R407C, isobutane, etc. Can be adapted for CO₂.
- Very low leakage reduces stop-start loss and minimum controllable flow.
- Ecovalve has been subjected to rigorous accelerated life tests, and showed no deterioration at the end of the equivalent of 15 years of service life.
- Digital control with an inexpensive

microprocessor

Ecovalve operates on the pulsed-flow principle. An electrically actuated reed valve is pulsed open at two second intervals. Flow rate is proportional to the fraction of the pulse interval during which the reed valve is open. That fraction is controlled by superheat as measured by thermistors. Stabilization of superheat is achieved with an inexpensive, passive, "superheat stabilizer", which performs the function of an expensive PID control and is, in its simplest form, a section of tubing typically 20 mm Diameter x 200 mm length, in the suction line preceding the thermistor that measures vapor temperature.

"The Coca-Cola Company, based on laboratory and field tests, endorses Global Cooling's expansion valve (sold as the "Ecovalve") as an option that can improve energy efficiency, increase the cooling capacity and lower initial pull-down time across a broad range of ambient operating temperatures of sales and marketing equipment. The installation of the Ecovalve is an effective tool to improve the environmental impact of new and refurbished sales and marketing equipment. A technical fact sheet is available on request or at www.globalcooling.com.

Please note that equipment that has been redesigned to include the Ecovalve would need to be submitted for re-certification to confirm performance and efficiency prior to our system's inclusion of the valve in its purchase plans."

Some Companies Using GC FPSC Technology!!

Companies		URL
<p>ISL (PAC group) Manufacturers of petroleum test equipment</p>		<p>www.paclp.com</p>
<p>Cimex (Cryopen LLC) Manufacturers of a cryosurgical device used in dermatological outpatient surgery called the Cryopen.</p>		<p>www.cryopen.com www.cimexbiotech.com</p>
<p>Apex Instruments Manufacturers of Environmental monitoring equipment</p>		<p>www.apexinst.com</p>

Shinyei

Exclusive Distributor of Twinbird
FPSC products in Japan



www.stirlingcooler.com

Asymptote

Manufacturers of Nitrogen-free
controlled rate freezers



www.asymptote.co.uk

Scinics

Manufacturers of -80C sample
transporter called the Cryoport



www.scinics.co.jp

Ametek

Manufacturers of portable block
calibrator called ATC-125



www.ametekcalibration.com

AvXcel

Manufactures of TropiKool Marine
Refrigeration Products



www.avxcel.com

Kodiak Thermal Technologies

Temperature regulated transport



www.kodiaktech.com

Coleman

Coleman® Stirling Power Cooler



www.coleman.com

Twinbird
Manufacturer of full line of FPSC
and related products



www.twinbird.jp



Global Cooling EEV

[EEV Info](#)



©2004 - 2008 Global Cooling - 141 North Columbus Road - Athens, Ohio 45701 USA - (740) 592-2655 - info@globalcooling.com



"Changing the Way the World Cools"

[Miniature Stirling Coolers](#)

D.M.Berchowitz

- Home

- About GC

- GC Japan

- Stirling History

- Stirling Links

- Contact Us

- Tech Overview

- What We Do

- How it Works

- Products

- Licensing

technical papers

Papers in PDF Format: Adobe Acrobat Reader is required to view these files.

Note: All Papers have been formatted for printing on 8.5 X 11 inch paper.

<i>Title</i>	<i>Author(s)</i>
"Operational characteristics of Stirling machinery"	Yong-Rak Kwon and D.M. Berchowitz
"Measurement and application of performance characteristics of a Free-Piston Stirling Cooler"	M. Janssen and P. Beks
"Experimental investigation of a Stirling cycle cooled domestic refrigerator"	E. Oguz and F. Ozkadi
"An electrical actuated reed valve for use as a pulse width modulated expansion valve"	R. Redlich, D.E. Kiiikka and D.M. Berchowitz
"Energy efficient freezer installation using natural working fluids and a free piston Stirling cooler"	S.C. Welty and F. Cueva
"Design and testing of a 40W free-piston Stirling cycle cooling unit"	D.M. Berchowitz, J. McEntee and S. Welty
"Maximized performance of Stirling-cycle refrigerators"	D.M. Berchowitz
"Experimental evaluation of a solar pv refrigerator with thermoelectric, Stirling and vapor compression heat pumps"	Michael K. Ewert, <i>et al</i>
"The application of Stirling cooler to refrigeration"	S.-Y. Kim, <i>et al</i>
"Recent advances in Stirling cycle refrigeration"	D.M. Berchowitz, D. Kiiikka and B.D. Mennink
"Stirling coolers for solar refrigerators"	D.M. Berchowitz
"Development of an improved Stirling cooler for vacuum super insulated fridges with thermal store and photovoltaic power source for industrialized and developing countries"	B.D. Mennink and D.M. Berchowitz
"Low cost small cryocoolers for commercial applications"	A. Karandikar and D. Berchowitz
"Free piston Rankine compression and Stirling cycle machines for domestic refrigeration"	D.M. Berchowitz
"Stirling refrigerators for Space Shuttle Experiments"	K. McDonald, D. Berchowitz, J. Rosenfeld and J. Lindemuth
"Estimated size and performance of a natural gas fired duplex Stirling for domestic refrigeration applications"	D.M. Berchowitz and J. Shonder
"An Experimental Study on the Refrigeration Capacity and Thermal Performance of Free Piston Stirling Coolers"	Emre Oguz and Fatih Ozkadi
Miniature Stirling Coolers	D.M.Berchowitz

["Hermetic Gas Fired Residential Heat Pump"](#)

D.M. Berchowitz and Yong-Rak
Kwon

["8th IEAHP Poster Presentation"](#)



"Changing the Way the World Cools"

Contact Information

contact us

Global Cooling, B.V.

Director:

Kerst Toxopeus

Lagedijk 22

5705 BZ Helmond

Phone: +31 492 450705

Global Cooling, US

141 Columbus Rd.

Athens, Ohio 45701 USA

Phone: (740) 592-2655

email: info@globalcooling.com

Global Cooling, Japan

Nobutoshi Tezuka, President

Kanagawa Science Park

East Tower 213

3-2-1, Sakado, Takatsu-ku

Kawasaki-City, Japan

Phone: +81-44-833-3233

Fax: +81-44-833-3692

e-mail: ftezuka@aol.com

www.globalcoolingjapan.com

Please use this form to send an email to Global Cooling. We will respond as soon as we are able.

* Indicates a required field.

* Name:

* E-mail Address:

Company Name:

Address:

City:

State / Providence:

Zip or Postal Code:

Country:

Phone Number:

Reason for Inquiry:

* Message:



"Changing the Way the World Cools"

M100B5-2 FPSC:

- Home
- About GC
- GC Japan
- Stirling History
- Stirling Links
- Contact Us

- Tech Overview
- What We Do
- How it Works
- [M100B5-2 FPSC](#)
- Tech Papers
- Licensing



2.81Kg / 6.2lb

Light weight design allows for integration into highly portable applications

100 Watt heat lift capacity at 0°C / 32°F

Up to 30 Watts of lift at -120°C / -184°F

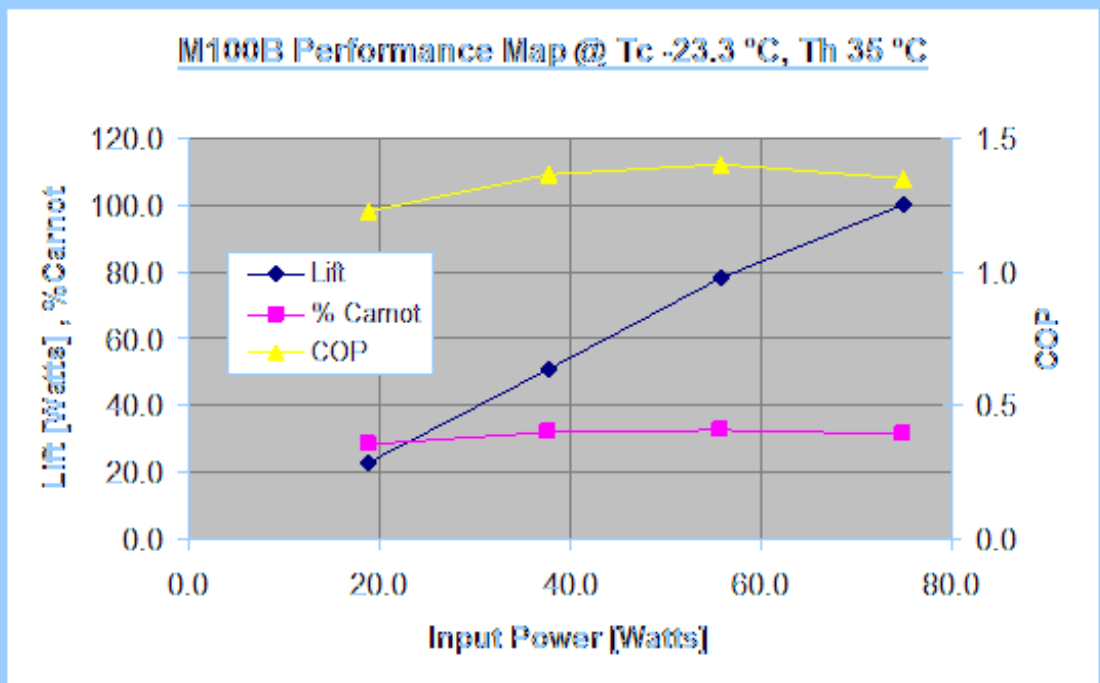

Highly Efficient

COP 2.0 @ 0°C / 32°F*

COP 0.21 @ -120°C / -184°F*

Capable of Sustained Operation at -120°C

No oils used for internal lubrication (uses helium gas)

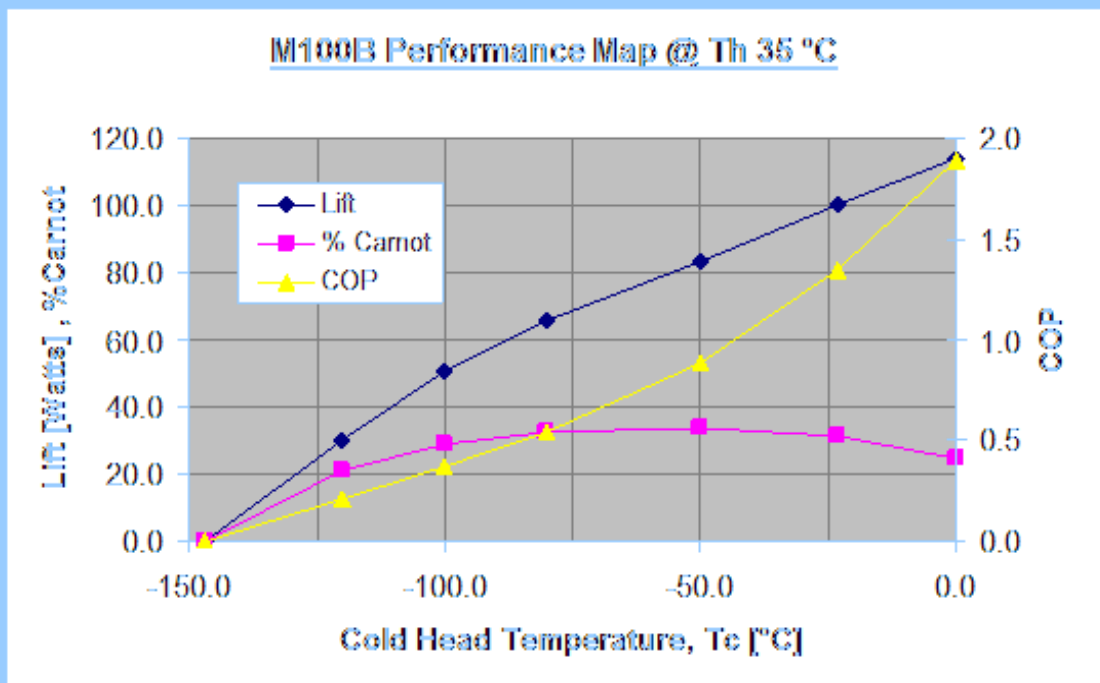

Extremely Long Lifespan

Moving Internal Components Supported by Global Cooling Gas Bearing technology

Essentially Zero Friction Between Internal Components During Operation

Extremely Compact Envelope

238.2mm / 9.34in long

108.2mm / 4.25in diameter

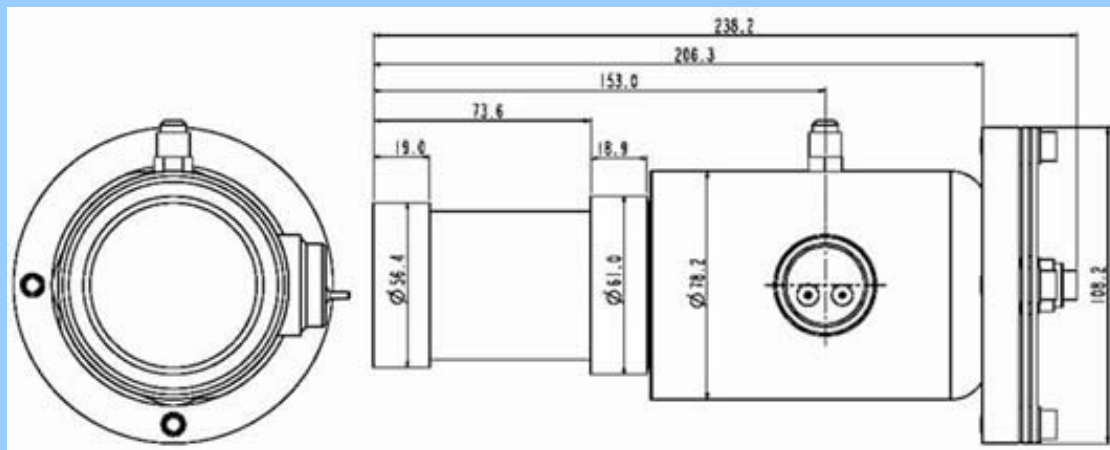

Hermetically Sealed

Cooling system can be serviced/replaced without opening FPSC module

Environmentally Benign

Uses only single phase Helium as refrigerant

* Indicated performance of the M100B is MAXIMUM lift under laboratory test conditions. MAXIMUM lift under actual product conditions can be 10-20% less.



"Changing the Way the World Cools"

- Home

- About GC

- GC Japan

- Stirling History

- Stirling Links

- Contact Us

- Tech Overview

- What We Do

- Products

- Tech Papers

- Licensing

how it works

Stirling Free Piston Stirling Cooler

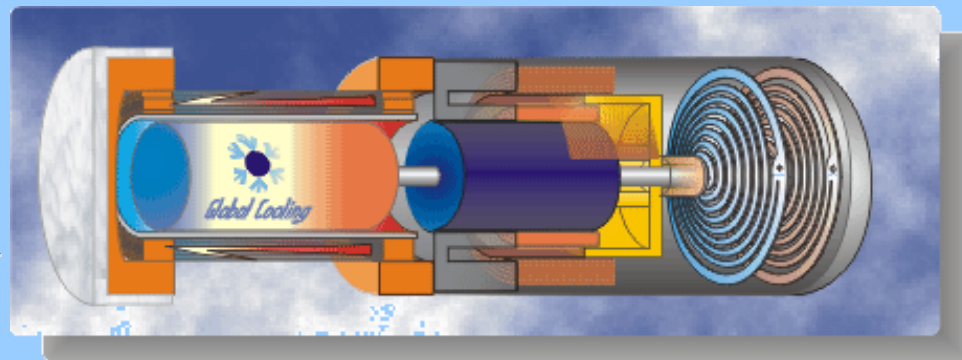

Figure 1 :FPSC Animation

The Free Piston Stirling Cooler (FPSC) is a device which makes use of the stirling cycle and a moving magnet linear motor for cooling applications. The stirling cycle belongs to a class of thermodynamic cycles that yield the highest conversion efficiency between mechanical and thermal energy.

The animation above shows how the machine works and the image below defines the components necessary to understand its operation. The stirling cycle is a reversible cycle which means that heat can be put into the machine and electric power will be produced or electric power can be put in and heat will be removed. The case of interest to us at Global Cooling is the latter of the two, the Free Piston Stirling Cooler.

FPSC DYNAMICS

The FPSC cycle starts with an AC input into the linear motor. This input drives a magnet ring which is rigidly attached to the piston (hence the term, moving magnet motor). The piston is the dark blue oscillating cylinder in the animation. The white oscillating cylinder is referred to as the displacer. The difference between the displacer and the piston is that the piston has two different pressures on either of its faces whereas the pressure on either end of the displacer is the same (assuming the pressure drop through the passages between the two

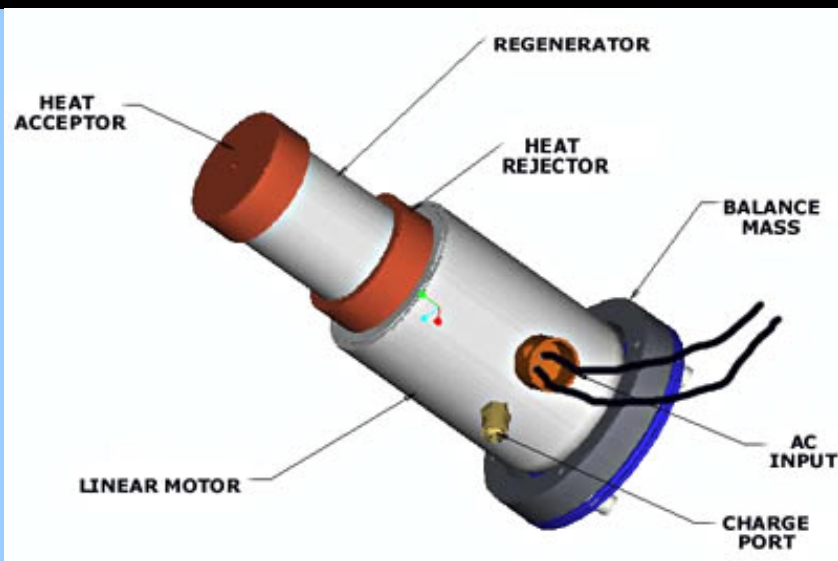

Figure 2 : Model M100B Image showing basic components of a FPSC.

faces is negligible). This means that the pink gas in the animation cannot flow back to the other side of the piston but the blue (cold) gas on one side of the displacer is free to flow back to the pink (hot) gas face of the displacer. The piston is driven by the linear motor since it is rigidly attached to the moving magnet ring. The displacer is driven by the force which arises because of the difference in areas of its two faces.

$$F = P_{amp} \cdot A_{disp} - P_{amp} \cdot (A_{disp} - A_{rod})$$

$$F = -P_{amp} \cdot A_{rod}$$

The pressure amplitude (P_{amp}) is the amplitude of the pressure wave . This is not the same as the overall pressure of the machine. The FPSC is hermetically sealed and is typically pressurized 20 to 30 times atmospheric pressure. The charge port shown in figure 2 is where the helium (working fluid) is introduced into the machine.

The absorber mass shown in figure 2 is a mass spring system that balances the machine. It is not shown in the animation but when the displacer and piston oscillate within the machine, the casing also oscillates. In order to mount it more easily without the transmission of vibration to a base, the absorber mass "absorbs" the vibration.

FPSC THERMODYNAMICS

Once the dynamics have started in a stirling cooler a very simple thermodynamic cycle ensues. To help in understanding the thermodynamics it is useful to look at a Pressure-Volume diagram. The ideal case will be as shown in figure 3.

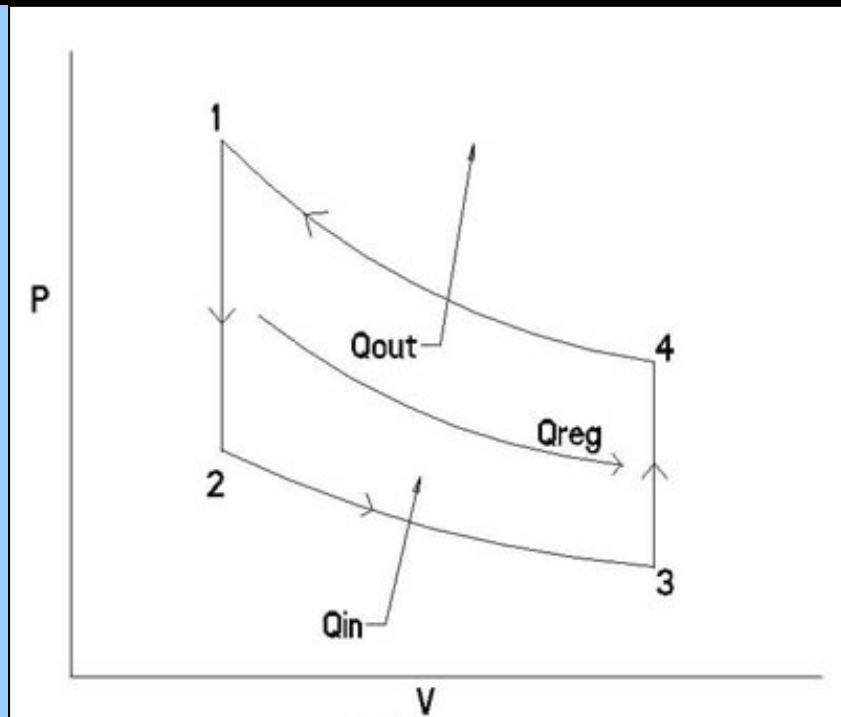

Figure 3 : Ideal Stirling Cycle Pressure-Volume Diagram

The ideal stirling cycle is made up of four totally reversible processes:

- 1-2 Constant volume regeneration (internal heat transfer from the working fluid to regenerator)
- 2-3 Constant temperature expansion (heat addition from external source)
- 3-4 Constant volume regeneration (internal heat transfer from regenerator back to the working fluid).
- 4-1 Constant temperature compression (heat rejection to external sink)

The actual stirling cycle has many losses associated with it and does not really involve isothermal processes so it is not totally reversible. Since the FPSC involves sinusoidal motion the edges of the p-v diagram are not sharp edges as indicated in the ideal diagram in figure 3. The actual p-v diagram ends up looking more like an oval with the sharp edges of the ideal diagram rounded off. However, the ideal diagram is useful for beginning to understand the cycle.

A simple second order analysis of the stirling cycle has been developed by Gustav Schmidt in 1871. The analysis has been used widely as an approximation of stirling performance. David Berchowitz and Israel Urieli give a complete description of it in their book [Stirling Cycle Engine Analysis](#).

[Download](#) the description of the Schmidt Analysis from the book.

COPYRIGHT AND TRADEMARK NOTICES

All contents of this Web site are Copyright of Global Cooling BV, and/or its suppliers. All rights reserved. Visitor may not modify, copy, distribute, reproduce, publish, license, create derivative works from, transfer, or sell any information, software, products or services obtained from this Web site. Products and company names mentioned herein are the trademarks of their respective owners.



"Changing the Way the World Cools"

Archives:

- [Home](#)

- [About GC](#)

- [GC Japan](#)

- [Stirling History](#)

- [Stirling Links](#)

- [Contact Us](#)

- [Tech Overview](#)

- [What We Do](#)

- [How it Works](#)

- [Tech Papers](#)

- [Licensing](#)

July 8, 2007

Global Cooling unveiled its newest example of an FPSC powered product. The InterPack 07 Conference in Vancouver, BC was the venue for the first public glimpses of the new SC-UL20 Ultra Low Temperature (ULT) freezer. The prototype version of the new ULT freezer was demonstrated to maintain internal temperatures in its 20 Liter cargo area below -80 degrees C in a 25 degree C ambient. The entire unit weighs less than 40lbs and consumes about the same amount of energy as a 100W light bulb (less than a tenth of the power consumption of competing systems)! The unit uses only two inches of non-CFC foam insulation and is easily carried by one person! Production versions are slated to be upgraded to vacuum insulated panel (VIP) insulation and be able to reduce the temperature of a 25 Liter payload to -100 degrees C using the same amount of power. The SC-UL25 will usher in a new era in ULT freezers allowing for quiet, compact, high efficiency designs to become standard in the industrial and biomedical industries. More Details to Follow.

February 2007

Global Cooling has begun development of a [Fuel Fired Home Heating/Cooling System](#) in cooperation with an EU consortium and other domestic and foreign investors. The new system will be capable of utilizing [Primary Energy](#) to provide heating and cooling to residential homes. Additionally the system can be configured to recover heat normally wasted into the atmosphere to provide domestic hot water and/or radionic heating. The new system can also generate a small amount of electricity that can be used to drive the associated pumps and fans needed to distribute the conditioned air allowing for autonomous operation. The new system is hoped to be ready for field trials within 2 years and full commercial availability in 3.

January 2006

FPSC Used for Electronics Cooling!

In many military and commercial applications, it is not uncommon for electronics to be exposed to conditions far outside the temperatures ranges they were designed for. It has become a goal of our Military to shorten the integration cycle of the newest electronics into our combat ready units. To this end there is a strong push to leverage commercial-off-the-shelf (COTS) electronics. In order to keep these non-hardened electronics operating in the extreme conditions seen by the armed forces, active cooling must be used. Enter the FPSC, offering long life, high efficiency, compact packages and the ability to operate in extreme conditions. Military needs and FPSCs seem to be a match made in heaven.

In some commercial applications, the conditions can become so harsh that no current electronics packages can survive for any practical amount of time. To combat this, active cooling must be used to control the temperatures seen by the electronics. Global Cooling is now finalizing designs for several FPSC machines, to be used to cool electronics/computers in extreme environments. This technology is hoped to be filtered down to consumer applications where Personal Computers are actively cooled and thereby able to increase their stable clock speeds by 3-6 times. This will allow for packaging and performance beyond the capabilities of any other current hardware system. This boost will benefit a wide variety of computer systems, including improved productivity for high-end scientific and engineering work stations, CAD systems and, of course, faster gaming!

©2004 - 2008 Global Cooling - 141 North Columbus Road - Athens, Ohio 45701 USA - (740) 592-2655 - info@globalcooling.com



"Changing the Way the World Cools"

[Home](#)
[About GC](#)
[GC Japan](#)
[Stirling History](#)
[Stirling Links](#)
[Contact Us](#)
[Tech Overview](#)
[What We Do](#)
[How it Works](#)
[Tech Papers](#)
[Licensing](#)
[Contact us:](#)

Global Cooling Mfg Co
94A N. Columbus Rd
Athens, OH 45701
(740) 592-2655
(740) 592-2695 fax

Twinbird Products:

The Twinbird Co. of Japan has licensed Free-Piston Stirling Cooler (FPSC) technology from Global Cooling. They have begun commercial production on several high performance, high efficiency, long lasting, low cost, portable refrigerators and freezers for the consumer and commercial marketplace. Twinbird also produces a variety of FPSCs that have been integrated into a number of products manufactured by other companies worldwide.

Global cooling acts as an exclusive distributor for Twinbird products in the North/South American, Middle Eastern and European markets.

Global Cooling Products:

FPSC User Manuals:

FPSC Integration Methods:

Dimensioned Drawings:

[▼ Demo Movie](#)

*Flash Format
(6.3MB)

[▼ Animation](#)

Get macromedia
**FLASH
PLAYER**

[SC-UB04/SC-TC04](#)
[▼PDF](#)
[▼PDF](#)

[SC-CA04](#)

- Made of Aluminum for Better Thermal Conduction to the Cold Side of FPSC Unit
- This will be installed on the cold side of FPSC unit (SC-TA04, SC-UA04, SC-TC04, SC-UB04) to take the heat from the object to be cooled.

- 12VDC Input
- 40W of heat lift at $T_c = -23.3$ deg C, $T_h = 35$ deg C
- COP 1.2 (with 57 degree C ΔT)
- programmable controller
- Suitable for Commercial/Industrial applications requiring low noise, compact size, precision temperature control, low power consumption or temperatures as low as -80 deg C
- Click image for additional information

[SC-C925](#)

- 5 temperature settings
- 25 L (0.88 Cuft) internal volume
- 14kg (34 lbs)
- 48 Watt max power consumption (40 deg C ambient with internal temperature set at -18 deg C; 10 W with 25 deg C ambient and internal temperature of 3 deg C)
- Uses no environmentally harmful refrigerants (Helium, Carbon Dioxide)
- Click image for additional information

[SC-SK04](#)

- Starter Kit for FPSC Unit This will be used with the control PCB (ESC-040S)
- attached to FPSC unit (SC-TA04, SC-UA04).
- Click image for additional information

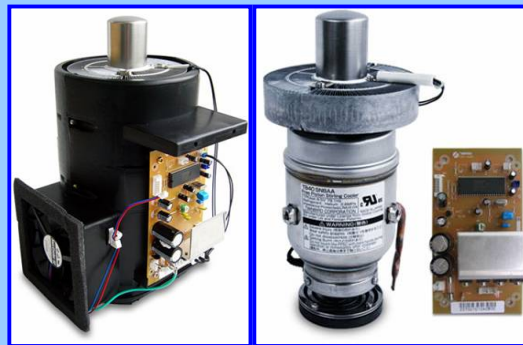
[SC-UA04/SC-TA04](#)

- 12VDC Input
- 35+W of heat lift at $T_c = -23.3$ deg C, $T_h = 35$ deg C
- COP 1.2 (with 57 degree C ΔT)
- Integrated temperature feedback control
- Suitable for consumer applications requiring low noise, compact size, precision temperature control, low power consumption or temperatures as low as -80 deg C
- Click image for additional information

[SC-DF25](#)

- Temperature adjustable in single degree increments from 12 deg C to -42 deg C
- 25 L (0.88 Cuft) internal volume
- 14kg (34 lbs)
- 48 Watt max power consumption (25 deg C ambient with internal temperature set at -40 deg C; 8 W with 25 deg C ambient and internal temperature of 3 deg C)
- Uses no environmentally harmful refrigerants (Helium, Carbon Dioxide)
- Click image for additional information



[SC-AD70](#)

- For Application Products Only
- Input Voltage: AC90 to 260V (Wide Range)
- Output: DC12V 5.8A 70W
- Click image for additional information



[SC-UD08/SC-TD08](#)

- 24VDC Input
- 60+W of heat lift at $T_c = -23.3$ deg C, $T_h = 35$ deg C
- programmable controller
- Suitable for Commercial/Industrial applications requiring low noise, compact size, precision temperature control, low power consumption or temperatures as low as -110 deg C
- Click image for additional information



[SC-HBV25](#)

- Single Temperature set point of 4 deg C
- 25 L (0.88 Cuft) internal volume
- 14kg (34 lbs)
- 48 Watt max power consumption
- Uses no environmentally harmful refrigerants (Helium, Carbon Dioxide)
- Click image for additional information



[SC-JS04](#)

- Single Temperature set point of 4 deg C
- Can be integrated into custom insulated container
- 6.7kg (14.8 lbs)
- 45 Watt max power consumption
- Uses no environmentally harmful refrigerants (Helium, Carbon Dioxide)
- Click image for additional information



[SC-UE15](#)

- 48VDC Input
- 120W of heat lift at $T_c = -23.3$ deg C, $T_h = 35$ deg C
- programmable controller
- Suitable for Commercial/Industrial applications requiring low noise, compact size, precision temperature control, low power consumption or temperatures as low as -120 deg C
- Click image for additional information



[SC-JS05](#)

- 3 Temperature set points of 4 deg C, -18 deg C and -35 deg C
- Can be integrated into custom insulated container
- 7.2kg (15.9 lbs)
- 80 Watt max power consumption
- Uses no environmentally harmful refrigerants (Helium, Carbon Dioxide)
- Click image for additional information



[Cool Cargo 200L](#)



[SC-AD150](#)

- For Application Products Only
- Input Voltage: AC90 to 260V (Wide Range)
- Output: DC12V 5.8A 70W
- Click image for additional information



[Cool Cargo FZ 100L](#)

©2004 - 2008 Global Cooling - 141 North Columbus Road - Athens, Ohio 45701 USA - (740) 592-2655 - info@globalcooling.com



"Changing the Way the World Cools"

Global Cooling Product Distribution:

Global Cooling Provides FPSC and EEV products to original equipment manufacturers (OEMs) for integration into commercial and consumer products.

GC Products:



[M100B5-2](#)

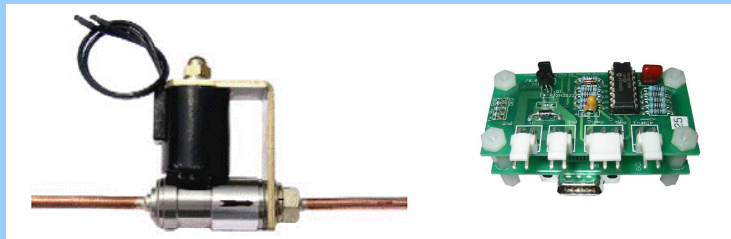

[Eco-Valve](#)

Global Cooling is also the exclusive distributor of the Twinbird FPSC line in the North American and European Markets.

Click below for additional information!

Twinbird Individual FPSCs:

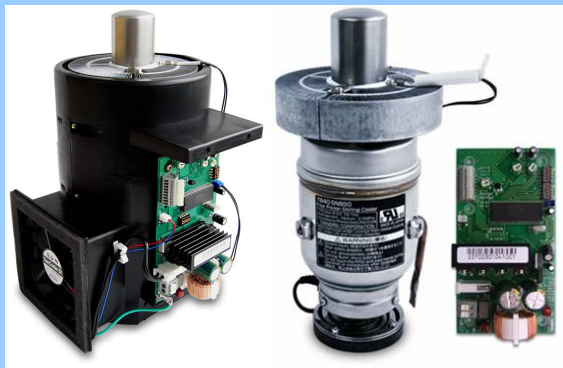

[SC-UB04/SC-TC04](#)



[SC-UA04/SC-TA04](#)



[SC-UD08/SC-TD08](#)

Twinbird Portable Refrigerator/Freezers:



[SC-C925](#)



[SC-DF25](#)



[SC-BV25](#)

©2004 - 2008 Global Cooling - 141 North Columbus Road - Athens, Ohio 45701 USA - (740) 592-2655 - info@globalcooling.com



"Changing the Way the

World Cools"

- Home

- About GC

- GC Japan

- Stirling History

- Stirling Links

- Contact Us

- Tech Overview

- What We Do

- How it Works

-

- Tech Papers

- Licensing

ECOVALVE ELECTRONIC EXPANSION VALVE

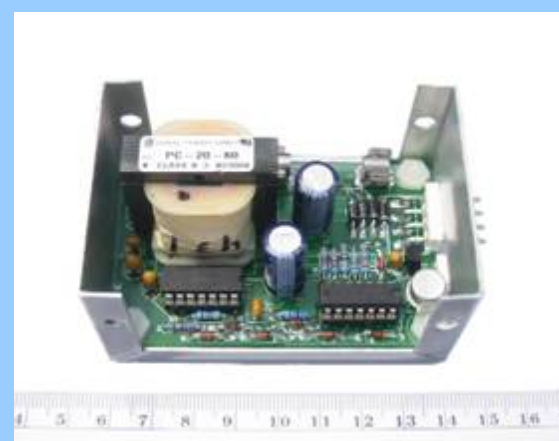

Unique Capabilities:

- Control of refrigerant flow down to exceptionally low rates of 15 W or less of refrigeration. A range of presently available orifice diameters enables flow control to 1200 W refrigeration, and higher flow rates are possible with a larger valve body.
- Maintains stable superheat of 3°C, even at low flow rates.
- Physically small and easy to install by brazing into the liquid line at the evaporator inlet. The control unit is small, easily installed, and uses only 0.5W average power.
- Works with all common refrigerants, e.g., R134a, R22, R407C, isobutane, etc. Can be adapted for

CO2.

- Very low leakage reduces stop-start loss and minimum controllable flow.
- Ecovalve has been subjected to rigorous accelerated life tests, and showed no deterioration at the end of the equivalent of 15 years of service life.
- Digital control with an inexpensive microprocessor

Ecovalve operates on the pulsed-flow principle. An electrically actuated reed valve* is pulsed open at two second intervals. Flow rate is proportional to the fraction of the pulse interval during which the reed valve is open. That fraction is controlled by superheat as measured by thermistors. Stabilization of superheat is achieved with an inexpensive, passive, "superheat stabilizer"**, which performs the function of an expensive PID control and is, in its simplest form, a section of tubing typically 20 mm Diameter x 200 mm length, in the suction line preceding the thermistor that measures vapor temperature.

ECOVALVE Installation

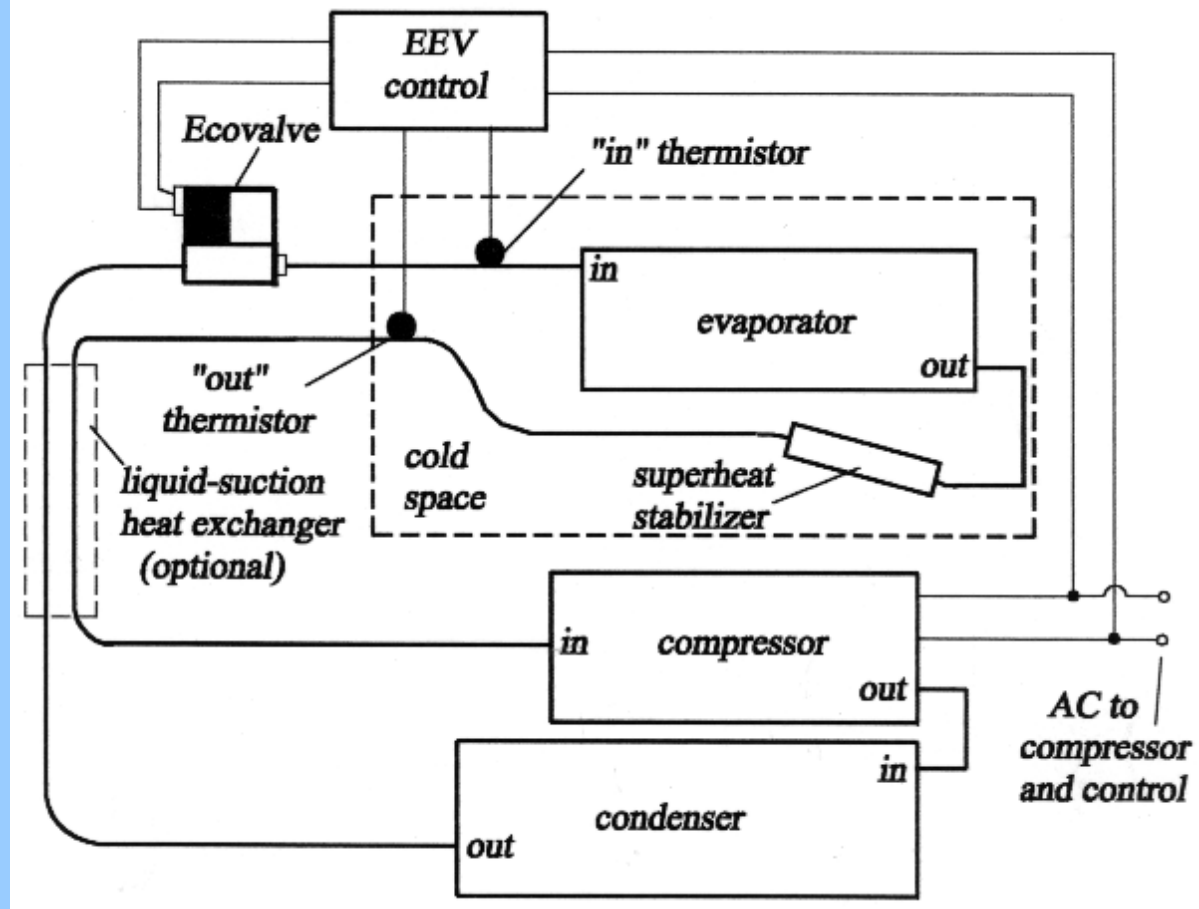

Ecovalve is supplied with a thermistor wiring harness terminated with resistance-matched thermistors and a connector that plugs into the control. Connectors for the EEV actuator coil and for AC power to the control are also supplied. If DC power for the control is available from existing supplies, a control without AC-DC power conversion is available at lower cost.

Specifications

Flow rate range is determined by orifice diameter, maximum duty cycle (duty cycle is defined as the ratio of valve-open time to pulse repetition interval), and minimum duty cycle. Minimum duty cycle is necessary to restart superheat control after prolonged compressor-off during which the evaporator reaches temperature

equilibrium. Max. and min. duty cycles are hard-wired into the control according to customer requirements.

Orifice Diameter (mm.)	Max Duty cycle	Min Duty Cycle	Typical R134a Refrigeration Range (Watts)
0.63	0.90	0.22	146 - 600
0.63	0.67	0.13	87 - 446
0.63	0.43	0.08	53 - 287

For larger or smaller orifice diameters, refrigeration range can be approximated by:

$$\text{Range with orifice Diameter } D \text{ (mm.)} = (D/0.63)^3 \times (\text{range with } 0.63 \text{ mm. orifice})$$

Orifice diameter will be supplied according to customer requirements.

Superheat set-point is $3.5^{\circ}\text{C} \pm 1^{\circ}\text{C}$ at midrange refrigeration and is hard wired into the control. Superheat varies with duty cycle by approximately $\pm 2^{\circ}\text{C}$, over the range of temperatures common in refrigeration.

December 2005:

The Coca-Cola Company, based on laboratory and field tests, endorses Global Cooling's expansion valve (sold as the "Ecovalve") as an option that can improve energy efficiency, increase the cooling capacity and lower initial pull-down time across a broad range of ambient operating temperatures of sales and marketing equipment. The installation of the Ecovalve is an effective tool to improve the environmental impact of new and refurbished sales and marketing equipment. A technical fact sheet is available on request or at www.globalcooling/gcjapan.html.

Please note that equipment that has been redesigned to include the Ecovalve would need to be submitted for re-certification to confirm performance and efficiency prior to our system's inclusion of the valve in its purchase plans.

* U.S. Patent 5,967,488. Other Patents pending

** U.S. Patent 6,260,368. Other patents pending

©2004 - 2008 Global Cooling - 141 North Columbus Road - Athens, Ohio 45701 USA - (740) 592-2655 - info@globalcooling.com



[Kundensupport](#)

- [US](#)
- [UK](#)
- [español](#)
- [français](#)

Domains kaufen

- [Domains parken](#)
 - [Was ist Domain parken?](#)
 - [Domains umleiten](#)
 - [Unsere Leistungen](#)
 - [Ihre Vorteile](#)
 - [Produkttour](#)
- [Domains kaufen](#)
 - [Domain-Suche](#)
 - [Domain Auktion](#)
 - [Domain Katalog](#)
 - [Domain-Vermittlung](#)
 - [Domain-Registrierung](#)
 - [Projekt kaufen](#)
 - [Tipps für Käufer](#)
- [Domains verkaufen](#)
 - [Domain-Verkauf](#)
 - [Domain Auktion](#)
 - [Domain-Showcase](#)
 - [Domain-Vermarktung](#)
 - [Projekt verkaufen](#)
 - [Tipps für Verkäufer](#)
- [Service](#)
 - [Übersicht](#)
 - [Domain-Bewertung](#)
 - [Domain-Transfer](#)
 - [Domain-Watchlist](#)
 - [Domain-News](#)

- [RSS Feed](#)
- [Domain-Recht](#)
- [Markenrecherche](#)
- [Partnerprogramm](#)
- [Kundensupport](#)
- [Über uns](#)
 - [Presse](#)
 - [Jobs](#)
 - [Preisliste](#)
 - [Mediadaten](#)
 - [AGB](#)
 - [Policies](#)
 - [Events](#)
- [Mein Sedo](#)
 - [Domain anbieten](#)
 - [Projekt anbieten](#)
 - [Domain Management](#)
 - [Domain Parking](#)
 - [Domain-Parking \(alt\)](#)
 - [Domain-Showcase](#)
 - [Eingegangene Gebote](#)
 - [Abgegebene Gebote](#)
 - [Buyer Control Panel](#)
 - [Transfers einsehen](#)
 - [Domain-Bewertung](#)
 - [Domain-Watchlist](#)
 - [Ihre Kundendaten](#)
 - [Passwort ändern](#)
 - [Ihre Bankdaten](#)
 - [Partnerprogramm](#)
 - [Zahlungsinformationen](#)
 - [Account-Zertifizierung](#)

- [Domain-Suche](#)
- [Domain Auktion](#)
- [Domain Katalog](#)
- [Domain-Vermittlung](#)
- [Domain-Registrierung](#)

- [Projekt kaufen](#)
- [Tipps für Käufer](#)

Domain Suche

Finden Sie hier
Ihre Wunschdomain!

➔ [Detailsuche](#)

Username

Passwort

- [Neu anmelden!](#)
- [Benutzername
oder Passwort
vergessen?](#)
- [Sicherheits -
Hinweis](#)

dresdner bank
>direct 24

5,25%

dresdner bank
direct24
Laufzeitkonto

- > Sichere Sparanlage der Dresdner Bank
- > 5,25% p.a. für 1 Jahr garantiert
- > Schon ab 1000€ Einlage

Jetzt 5,25% p.a. sichern

 **Dresdner Bank**
Die Beraterbank



Domains kaufen Exklusive

Top-Domains erwerben!

globalcoolingjapan.com (GLOBALCOOLINGJAPAN.COM) steht zum Verkauf

Preisvorstellung des Anbieters:

Gebot abgeben

Ihr Gebot:

Gebot abgeben

Angebotsdetails

Die Domain(ohne Website) wird vom Inhaber über Sedos Marktplatz zum Verkauf angeboten. Geben Sie ein Gebot ab, wenn Sie die Domain erwerben möchten.

[Domain beobachten](#)

Domain Statistics

Besucher dieser Angebotsseite:

1 (Auswertungszeitraum = 31 Tage)

Suchmaschinen-Rankings:

[Ranking-Report ansehen](#)

Erfahren Sie mehr über den Verkäufer

[Loggen Sie sich ein](#) oder [legen Sie sich einen Account an](#) um mehr über den Verkäufer zu erfahren

Alle angegebenen Preise sind Endpreise. Die marken- und namensrechtliche Überprüfung des Domain-Namens ist vom Kunden vor der Beantragung durchzuführen.

- [Home](#)
- [Über uns](#)
- [Preisliste](#)
- [Mediadaten](#)
- [Partner](#)
- [AGB](#)
- [Policies](#)
- [Kundensupport](#)
- [Impressum](#)
- © 1999-2008 Sedo

Climate change is arguably the most vital issue facing mankind today. Ban Ki-moon, United Nations secretary-general, has said tackling the threat of climate change is “the defining challenge of our age”. In the second of a three part series, the FT looks at the politics of climate change.

INTERACTIVE



- [Ask the expert](#)
- [Professor Jean-Pascal van Ypersele of the IPCC answers your climate change questions](#)



- [Interactive charts](#)
- [Geographical snapshot of CO2 emissions and timeline of events](#)



- [Join the discussion](#)
- [Can global leaders agree a successor to the Kyoto Protocol?](#)

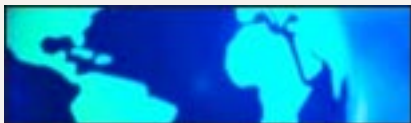

- [Audio map](#)
- [FT correspondents discuss climate change in their regions](#)

ONLINE EXCLUSIVES



- Tony Blair
- Governments have just 16 months to agree to a binding treaty



- José Manuel Barroso
- Developing an efficient carbon trading market is the key

PART ONE HIGHLIGHTS

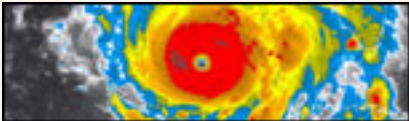

- Vicious cycles
- Pressure is on to find a global response to climate change



- Unnatural state
- As Indonesia's forests burn, its CO2 emissions keep rising



- Carbon is key
- Failure to act quickly could be catastrophic, says Sir David King



- Kyoto costs lives
- Forget climate change, fight poverty, argues Bjørn Lomborg

MORE FROM FT.COM



- Read the latest climate change stories from the Financial Times

**content
and
features**



Divided we stand

The US and China are showing a growing willingness to agree on emissions cuts but new dissent from developing countries threatens to hamper the negotiations, writes Fiona Harvey - Sep-15

Change reactions

The pace of global warming means adapting to its effects is essential, but the challenges facing developing countries and the natural world are immense.

Clive Cookson reports - Sep-15

A clear danger

Deforestation accounts for 20 per cent of emissions but doubts remain over how best to stop it - Sep-15

Growing concerns

Changes in temperature and precipitation threaten to add to existing stresses on agricultural resources - Sep-15

At boiling point

Military leaders warn that global warming is escalating tensions in the world's conflict zones - Sep-15

DEVELOPED WORLD

The debate leader

Despite its divisions, the European Union has advanced the cause of climate change and engaged developing countries

Matters of import

The intersection of climate change and global trade policy has caused tensions to rise across the world

A pledge too far

Despite its high standards of energy efficiency, Japan is struggling to meet the commitments it made at Kyoto

Braced for change

The climate change community is eagerly anticipating a change of president in the US

EMERGING ECONOMIES

Trade off

Carbon credits offers a valuable boost to emission-cutting projects in developing countries but the mechanism has proved flawed

Boom and gloom

Beset with pollution, China has set ambitious targets for reducing carbon emissions, but will it be enough?

Solutions at hand

Putting green technologies to use is key to helping developing countries lower carbon emissions

Emerging targets

Schemes to reduce emissions in emerging economies are gaining acceptance as governments wake up to the potential rewards

Mobilising money

Despite efforts to help developing countries cope with climate change there is little consensus on how best to raise and distribute funds

Growing green

India resists emissions caps but now it is finding financial advantage in going green

COMMENT

Breaking the deadlock

Online exclusive: Governments have only 16 months to agree a new international treaty on climate change, says the former UK prime minister

Reach out to the world

The Democratic candidate's strategy centres on re-engaging with the global community, writes an adviser to Barack Obama

Drastic action required - today

The executive secretary of the UNFCCC says the world must reach agreement on a way forward in Copenhagen

Global threat is opportunity

Online exclusive: Developing an efficient carbon trading market is key to reducing emissions, writes the president of the European Commission

Creating a market-led solution

The Republican candidate would employ incentives in tackling climate change, says the chief economic adviser to John McCain

Developed states must lead

To restore equity on global action, rich countries must take the lead on emissions, argues the president of Brazil

INTERACTIVE

Climate change agreement



As a new generation of leaders negotiate a successor to Kyoto, is agreement possible?

Mapping carbon dioxide emissions

A geographical and US state-by-state snapshot of carbon dioxide emissions and timeline of major events in climate change negotiations

CLIMATE CHANGE: PART ONE - SCIENCE

- [Vicious cycles](#)
- [Heat and myth](#)
- [Nearing meltdown](#)

- [Unnatural state](#)
- [Taking the rains](#)
- [Carbon is key](#)
- [On the ground](#)
- [British Antarctic Survey](#)
 - [Model behaviour](#)
 - [Painful cuts](#)
 - [Beyond drought](#)
 - [Just add water](#)
 - [Agents of change](#)
 - [Stalled warming](#)
 - [Kyoto costs lives](#)

[FT Home](#)

[Site map](#)[Contact us](#)[Help](#)

Advertise with the FT [Media centre](#) [FT Newspaper subscriptions](#) [FT Conferences](#) [FT Syndication](#) [Corporate subscriptions](#) [FT Group](#) [Careers at the FT](#)
Partner sites: [Chinese FT.com](#) [The Mergermarket Group](#) [Investors Chronicle](#) [Exec-Appointments.com](#) [Money Media](#) [The Banker](#) [Di Intelligence](#) [MBA-Direct.com](#) [The Non-Executive Director](#)

© Copyright [The Financial Times Ltd](#) 2008. "FT" and "Financial Times" are trademarks of The Financial Times Ltd. [Privacy policy](#) [Terms](#)

Facts & Arts

Articles, music and films by independent producers
for you to enjoy and debate

- [Home](#)
- [Articles](#)
- [Music](#)
- [Videos](#)
- [Letter from the Editor](#)
- [For Content Providers](#)

Would you
like to see
your ad here?

Please contact
info@factsandarts.com

Articles

[Most recent](#) [Most downloaded](#) [Best rated](#)

Barack Obama's 30 min TV Advertisement: American Stories, American Solutions

by Added 30.10.2008

Barack Obama - Joe Biden campaign ran on Wednesday 29, 2008, a 30 minute television advertisement on almost all major TV channel in the USA. Please watch it here, and comment it if there is something you want to say to the FACTS & ARTS'...

Why Barack Obama?

by Richard Holbrooke Added 28.10.2008

NEW YORK - The winner of America's presidential election will inherit a perfect storm of problems, both economic and international. He will face the most difficult opening-day agenda of any president since - and I say this in all seriousness -...

Free Market Blues: President Bush Still Believes

by Binoy Kampmark Added 28.10.2008

The free market apostates continue to battle the market. The corporate sector has beaten a hasty retreat. Credit, frozen globally, is being edged out by capital injections into various financial institutions. The realisation that freedom and the...

From Financial Meltdown to Global Depression?

by Nouriel Roubini Added 27.10.2008

NEW YORK - The rich world's financial system is headed towards meltdown. Stock markets have been falling most days, money markets and credit markets have shut down as their interest-rate spreads skyrocket, and it is still too early to tell...

Modern China Emerged Before Its Encounter with the West

by New Quarterly Perspectives, NQP Added 27.10.2008

Wang Hui, China's leading "new left" intellectual and the former editor of the prestigious journal, Dushu, is author of The Rise of Modern Chinese Thought, the seminal historical work

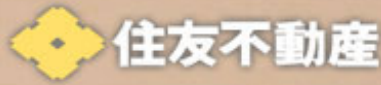

For Japanese >

Tel. 0120-770-507

Contact

トップ
Top

高級賃貸マンション“ラ・トゥール”
Highest level rental apartment “La Tour”

物件を探す
Property Search

サービスアパートメント
Service Apartment

お勧め物件
Recommend

ペット可マンション
Pet Friendly Apartment

Q&A
Q & A

Topics

2008/9/22

*Completion schedule in April, 2009

[Platine Nishi-Shinjuku](#)

Beginning of wanting member of homepage opening to the public

2008/9/1

*We are launching “Car Sharing Service” at Platine Shinjuku-Shintoshin!! BMW and Toyota Prius is only an elevator away. Click here for more info.

[Click here for more info on the property](#)

2008/8/8

*We are now allowing large-size dog at La Tour Mita!
(please consult your agent) Enjoy a life with your precious pet.

[Click here for more info on the property](#)

2008/7/17

**Highest level
rental apartment
“La Tour”**

La Tour Series
Featured the highest grade
“La Tour” series of
Sumitomo Realty
& Development.

Property Search

Rental Object Search
Evolve urban rent apartment

**Service
Apartment**

Service Apartment Search
Service Apartment
for rent.
Available from
a month contract

*Brand new property, "Platine Shinjuku Shintoshin"
During the campaign period, no key money required.



[Click here for more info](#)

[Top](#) | [Contact](#) | [Privacy Policy](#) | [Sitemap](#) | [Sumitomo Realty & Development Co., LTD.](#)

Copyright 2007 (C) Sumitomo Realty & Development Co., LTD. All Rights Reserved.

www.japantea.hu
a japán teák oldala

Keresés

-  Oldaltérkép
-  Kosár tartalma (0)



Információk

- Tea történelem
- Teák japánul
- A japán tea eszközei
- A japán teák elkészítése
- A japán teák tárolása
- Tea irattár
- Marukyu Koyamaen
- Tea receptek
- A japán teák és az egészség
- Tea kóstoló
- Japán tea fórum
- Japán tea az interneten
- A teaház



Noami: Hasu Zu (Lótusz)
1471

Masaki Képzőművészeti Múzeum Osaka

Aláírás: az idős, 75 éves No

寺
久
小山園

Japán Aruház

- japán teák (100)
- chanoyu eszközök (62)
- sencha készletek (20)
- tetsubin - öntöttvas teáskannák (2)
- kyuusu - a japán teáskanna (14)
- yunomi teáscsészék (4)
- Teatartók (5)
- Chabana - japán virágvázák (6)
- kimonók (1)
- víztisztítók (2)

Gyártók

- Chakraku (8)
- Coolpex (2)
- D&B (3)
- Kimura Takaaki (1)
- Marukyu Koyamaen (95)
- mitsuke fumio (1)
- Nagahiro Yashumori Horaido (44)
- Nagahiro Yasumori (1)
- NoNoDa (18)
- Pagace Pagasari (9)
- rakuten (26)
- Shibuya Deishi (2)
- Takahashi Rakusai (1)
- Yamane Seigan (5)

Üdvözöljük a japán teák világában!

Cégünk Marukyu Koyamaen közép-európai képviselője.

Látogassa meg Marukyu Koyamaen megújult weblapját [itt](#)

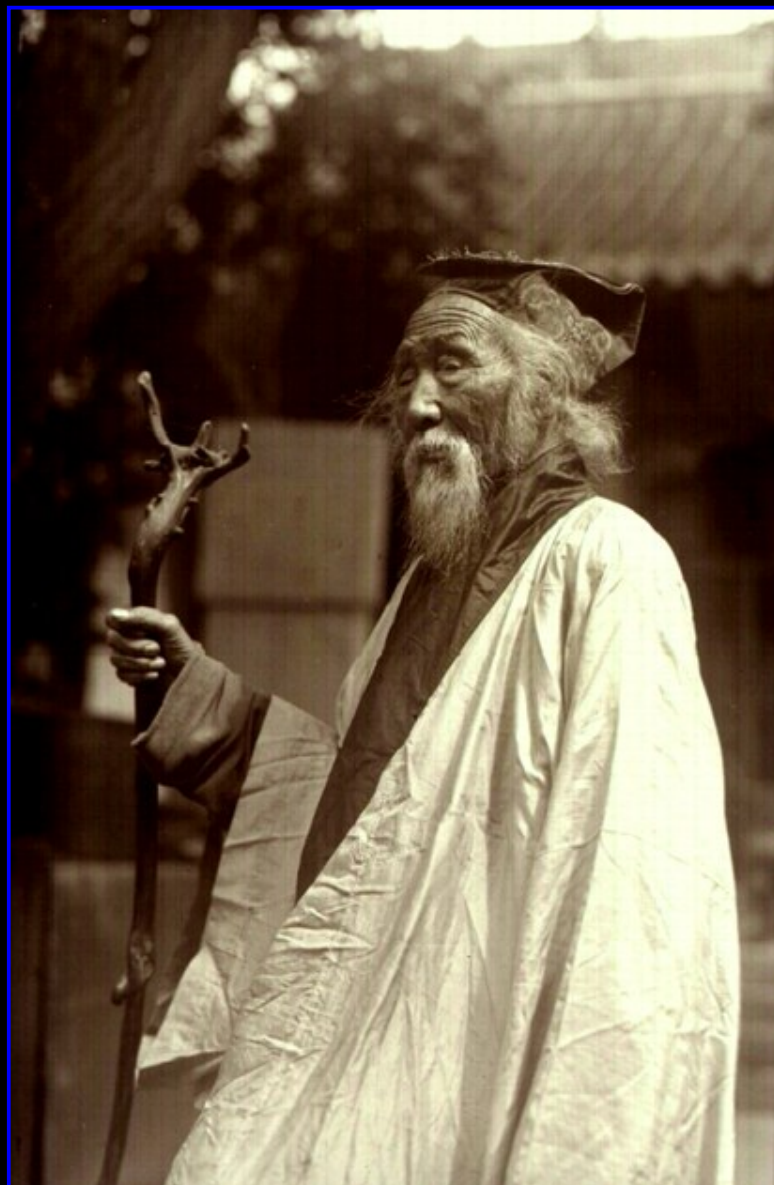

Címlapon: A tea, mint világrend

Tetsubin - a japán teáskanna I. rész





Shincha 2008

Az első
tea



A részletekért kattintson a képre, vagy ide.

A japantea.hu folyamatosan frissülő és bővülő weboldal. Köszönjük, hogy megtisztelt figyelmével!

E-mail címünk: diem@diem.hu

Testvérünk www.teautja.hu
www.puerh.hu

KÉSZÍTETTE A  COLOUR-SYSTEM
DIGITAL STUDIO

[↑ vissza a lap tetejére](#) [● Kapcsolat](#)

Copyright © 2006 Carpe Diem Teaház, Debrecen. Minden jog fenntartva.



Bible and the Contemporary World



School of Divinity, University of St Andrews, Scotland
online, graduate, distance learning

The University of St Andrews is a charity registered in Scotland, No SC013532.



SUBSCRIBE

- Give a gift
- Manage my subscription

A MAGAZINE OF EVANGELICAL CONVICTION

ChristianityToday

magazine



October 30, 2008

NEWS OPINION BLOGS REVIEWS INDEX ARCHIVES CONTACT US

Free E-mail Newsletters:

[RSS Feed](#) | [More Feeds](#) | [RSS Help](#)

SEARCH

Global Warming and the Environment

Recently evangelicals have become the surprise proponents of policies promoting care for creation, including halting global warming. Though by no means are evangelicals of one mind on the subject, stewardship of God's creation is a Biblical principle most evangelicals agree on. Below, we have collected *Christianity Today's* coverage of climate change and creation care.

Climate Change

[Second Coming Ecology](#)

We care for the environment precisely because God will create a new earth.

by David Neff | posted 07/18/2008

[Climate Change Is Here to Stay](#)

Debate over global warming has only intensified since conservatives targeted Cizik.

by Sheryl Henderson Blunt | posted 03/30/2007

[Dobson, Others Seek Ouster of NAE Vice President](#)

Interim president Leith Anderson says he supports Richard Cizik's work on creation care.

by Adelle M. Banks, Religion News Service | posted 03/02/2007

[Cool on Climate Change](#)

New Christian coalition says fighting global warming will hurt the poor.

by Sheryl Henderson Blunt | posted 09/26/2006

[The New Climate Coalition](#)

Evangelical leaders bolster the fight against global warming.

by Sheryl Henderson Blunt in Washington, D.C. | posted 02/08/2006

[Environmental Wager](#)

Why evangelicals are—but shouldn't be—cool toward global warming.

by Andy Crouch | posted 08/04/2005

[Climate Change Briefing Brings Together Christian Aid Groups](#)

Rising temperatures will disproportionately affect the poor, say analysts.

by R. Scott Nolen | posted 10/19/2004

[Heat Stroke](#)

The climate for addressing global warming is improving.

A *Christianity Today* editorial | posted 09/16/2004

[Tending the Garden](#)

Evangelicals and the environment.

by John Wilson | posted 07/07/2004

[Religious Leaders Rebuke Bush Administration Over Kyoto Protocol](#)

Officials from the National Council of Churches, Presbyterian Church (USA), United Methodist Church, Disciples of Christ, and African Methodist Episcopal Church say U.S. must limit greenhouse gas emissions.

by Edmund Doogue | posted 4/6/2001

[U.S. Churches Join Global Warming Debate](#)

Environmental stewardship is an act of compassion toward the poor, say mainline Protestants and evangelicals, who are joining with other faith groups to reduce the effects of global warming.

(October 5, 1998)

Environmentalism

[Weeping for the Jordan](#)

Revered river endangered by pollution, overuse.



SHOPPING

ChristianBook.com
Music CDs | Books
Videos | Gifts
Downloads

Bible Studies
Christian History
Classifieds
Leadership Training
Small Group Resources

Featured Items

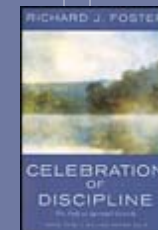

Celebration of Discipline

by Richard J. Foster

Reg: \$23.95

Now: \$13.99

by Michele Chabin, RNS, with reporting by Elizabeth Lawson | posted 08/28/2007

DO LIKEWISE

Old-Fashioned Creation Care

Thrift and care for the environment go hand in hand.

by David P. Gushee | posted 07/16/2007

Cleaning Up La Oroya

How American and Peruvian Christians teamed up when factory pollutants were poisoning children.

by Hunter Farrell | posted 04/20/2007

Bald Eagles and Babies

The case for compassionate conservationism.

by John E. Silvius | posted 6/27/01

Eco-Myths

Don't believe everything you hear about the church and the environmental crisis.

by David N. Livingstone, Calvin B. DeWitt, and Loren Wilkinson | posted 6/27/01

CT CLASSIC

Why We Love the Earth

Our belief in a Creator, not crisis scenarios, drives our environmental concerns.

A *Christianity Today* Editorial by Howard A. Snyder | posted 6/27/2001

Greening of the Gospel?

Evangelical environmentalists press to add creation care to the church's mission.

by Randy Frame | posted November 11, 1996

God's Green Acres

How Calvin DeWitt is helping Dunn, Wisconsin, reflect the glory of God's good creation.

by Tim Stafford | posted June 15, 1998

sponsors

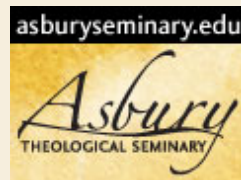
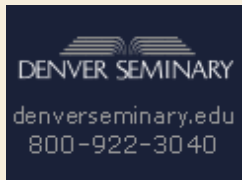

[Browse More Christianity Today]

[Reader Reviews](#) are below

START YOUR RISK-FREE TRIAL NOW!



unChristian

by David Kinnaman

Reg: \$17.99

Now: \$11.99



3 RISK-FREE TRIAL ISSUES



Subscribe to *Christianity Today* magazine today!

BIBLE STUDIES

- Top Sellers
- Hot Topics
- Bible Study Courses
- Quarterly Study Plans
- Movie Discussion Guides

Free newsletter:





START YOUR RISK-FREE TRIAL NOW!

Subscribe to Christianity Today and get 3 free trial issues. No credit card required.

Please allow 4-6 weeks for delivery. Offer valid in U.S. only.

If you decide you want to keep *Christianity Today* coming, honor your invoice for just \$19.95 and receive nine more issues, a full year in all. If not, simply write "cancel" across the invoice and return it. The three trial issues are yours to keep, regardless.

[Click here for international orders](#) **2-for-1 Gifts!**



Sponsored by Tyndale

NEW TODAY

- A Variety of Evangelical Politics
- Quotations from the News
- How Character Shapes Belief
- Editorial: Misunderstanding Sarah
- Editorial: Can We Come to the Party?
- Go Figure
- Bookmarks: Three Short Reviews
- Schullers Part Ways at Crystal Cathedral's *Hour of Power*
- Keeping the End in View
- Poll: Have you read a book on politics this fall?

[New this week](#)

SEMINARY/GRAD SCHOOL GUIDE

Search by Name

Or use Advanced Search to search by program, region, cost, affiliation, enrollment, more!

Search by:

- Location & Setting
- Programs & Degrees
- Enrollment
- Affiliation
- Athletics
- Costs, Scholarships & Grants

- [List All Schools](#)

RELATED SITES

- [Books & Culture](#)
- [Christian History Biography](#)
- [Faith in the Workplace](#)

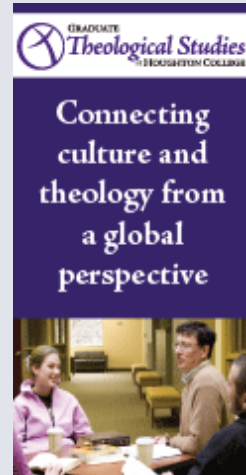

Magazines & Periodicals

- | | | |
|---|------------------------------------|--|
| Books & Culture | Ignite Your Faith | Today's Christian Woman |
| Christianity Today | Leadership Journal | Your Church |
| Church Law & Tax Report | Men of Integrity | ChristianityTodayLibrary.com |
| Church Finance Today | Outcomes | PreachingToday.com |
| Church Secretary Today | | |



© 2008 Christianity Today International | [About Us](#) | [Privacy Policy](#) | [Contact Us](#) | [Customer Care](#) | [Advertise with Us](#) | [Job Openings](#) | [Help](#)

Bible and the Contemporary World



School of Divinity, University of St Andrews, Scotland
online, graduate, distance learning

The University of St Andrews
is a charity registered in
Scotland, No SC013532.



BBC NEWS | Business | Investors urge action on climate change

news.bbc.co.uk/2/hi/business/7004372.stm

Published in: GB  • Text refers to: United States • Mirror Date: 2007-09-26

Last Updated: Sunday, 23 September 2007, 23:12 GMT 00:12 UK. Investors urge action on climate change. By Jorn Madslie. Business reporter, BBC News. US President Bill Clinton. President Clinton wants companies to act against climate change. Bill Clinton will be taking a leaf out of his political ally Al Gore's book on Monday as he takes part in the New York launch of a major study of large, global corporations' attitudes to climate change. In the current climate, much of what the Global Corporate Climate Change Report says appears obvious: most companies have come to realise that climate change is going to have a major impact on their business, and many of them also realise that there will be winners as well as losers. But what is truly different about this report is that it is backed by a group of 315 of the world's largest investment houses with \$41 trillion under management - equivalent to three times the annual economic output of the US. "That's why President Clinton is prepared to endorse this initiative," the Climate Disclosure Project's chief executive, Paul Dickinson, tells BBC News in an interview. Market leaders. In a world where money is power, the group of investors have asked the biggest companies in the world to identify how climate change is going to affect their businesses, and to report back their findings. Many of them have done so. Indeed, the Global Corporate Climate Change Report is essentially a compilation of a whopping 1,300 reports from major international corporations revealing both what impact they are having on the environment, and what impact changes to the environment are having on their commercial operations. Many of them are investing heavily to try to reduce their carbon footprint, in order to cut back on costs that are forced higher by climate

Key Findings

the chief executive of the giant French insurance
 er than both exchange rate risk and interest rate
 nities posed by climate change - making profits
 es. To illustrate his point he highlights the example
 n reducing engine technologies, like Toyota and
 ng market share. Little action. But not all
 ting their business, the Global Corporate Climate
 estor. Investors fear the chaos of climate change.
 KPMG in the UK, which found that a fifth of
 y important issue" for their business. But
 n Brothers economist John Llewellyn, who last
 ss of Climate Change II. True, many companies
 reduce **emissions** before their rivals do so,
 compete, explains Mr Llewellyn, but this does not
 ese companies will invest in **emission**-reducing
 technologies, but only once there is a regulatory and legislative framework in place that ensures a
 level playing field. Hence, the suggestion in the YouGov/KPMG study that 86% of business
 leaders interviewed do "not have a strategy in place for responding to climate change" does not
 mean they will not have one in the future. "You don't want to be the first mover," Mr Llewellyn tells
 BBC News. "The policy response as much as climate change itself will affect companies'
 responses. " Green investments. "So far - or at least until recently - polluters, particularly emitters
 of **greenhouse gases**, have not had to pay for the damage they have caused," Mr Llewellyn points
 out in his report. "Hence, they have had no economic incentive to limit them. " Share prices will

increasingly be affected by [environmental](#) performance. John Llewellyn, Lehman Brothers. But over time "businesses will be obliged to internalise the climate change externality", he says. In other words, polluters will have to start paying for damage they cause. Mr Llewellyn also predicts that policy initiatives aimed at curbing climate change will increasingly be hammered out by treasuries and finance ministries, rather than by environment, technology, industry or energy ministries as is often the case today. In short, governments will meet the need to reduce [greenhouse gas emissions](#) with a search for the cheapest way to do so. Technologies that deliver significant [emission](#) reductions in return for every pound or dollar spent will be favoured over expensive technologies that deliver relatively small [emission](#) reductions per pound, he predicts. For instance, \$10 spent on [energy efficient](#) light bulbs would reduce carbon [emissions](#) by one tonne. To achieve the same reduction in [emissions](#) by insulating houses would require an investment of \$130, while some \$500 would need to be spent on solar panels to achieve the same result. By extension; spending that \$500 on [energy efficient](#) light bulbs would reduce [emissions](#) by 50 tonnes - so it makes sense to change the light bulbs before investing in house insulation. And only when that has been done should solar panels be acquired, and this is as true for society as a whole as it is for individual households. Treasuries and finance ministries are also expected to try to calculate the cost of climate change, by trying to estimate the cost of the damage it is causing. Finance ministers and chancellors will then be pushing through green initiatives, though only so long as the damage costs more than the repairs. Cautious investors. But whereas companies - and indeed governments - are increasingly investing to reduce their carbon footprint, there is little evidence that their efforts attract targeted investment, according to a study by communications consultants Headland. The study, which was based on interviews with 19 leading fund management houses in the UK, found that "there remains a clear disconnect between the apparent seriousness of this issue and attitudes of institutional fund managers". "Respondents revealed very little evidence of investment firms incorporating climate change in top-down investment strategies", the study found. Again, predicts Mr Llewellyn, this will change over time. "Share prices will increasingly be affected by [environmental](#) performance," he says in his report. "While share prices will continue to be driven by the usual macroeconomic, sectoral and company-specific determinants, they will also increasingly be affected by companies' [environmental](#) performances, including their [emissions](#) of [greenhouse gases](#). CLIMATE CHANGE. Factory graphic Animated guide. Find out how the [greenhouse effect](#) works and more. .. GLOBAL POLITICS. Politicians sign new climate pact. China building more power plants. EU/UK POLITICS. Tory group backs new flight tax. Parties 'failing' on green issues. IPCC ASSESSMENT. Climate change 'can be tackled' Billions face climate change risk. Stark picture of warming world. Mapping climate change. Climate curbs: Who will buy. Through the climate window. Climate action 'needs devolution' Power station harnesses Sun. Scrutinising climate economics. Q&A: Climate change. The evidence. Models 'key to climate forecasts' Earth - melting in the heat. INTERACTIVE. Rich pay poor to cut carbon. FROM ACROSS THE BBC. Climate change portal. Carbon Disclosure Project. The Business of Climate Change II. * Deep-voiced men 'have more kids' * Up to 100 jobs may go at foundry. * Serpentine's spinning top design. Most Popular Now | 42,000 pages were read in the last minute.



HOME

A&E

LIFE

HEALTH

SPORTS

BUSINESS

SCITECH

POLITICS & SOCIETY

ENVIRONMENT



MY CHANNELS

[HOME](#) > [PUBLICATIONS](#) > [Newsweek](#)

Newsweek

Newsweek offers comprehensive coverage of world events with a global network of more than 60 correspondents reporting on National and International Affairs, Business, Science & Technology, Society and Arts & Entertainment.

BROWSE PUBLICATION

•

-

- [Related Publications](#)

Articles

The Death Of The Dissident

Newsweek | Nov 03, 2008

Russian nationalism is surging, and now even one-time liberals are turning away from the West. For centuries, a good majority of Russia's young and well-educated elite have looked westward for inspiration and role models—some of them revolutionary like Karl Marx, or more recently free marketers like Margaret Thatcher.

Hot Spot: Copenhagen

Newsweek | Nov 03, 2008

MIELCKE & HURTIGKARL A stroll through the Royal Danish Garden Society whets the appetite for the nine-course "Inspiration Menu" at this eatery, tucked into a corner of the gardens in a renovated 17th-century military installation.

Piper, Please Don't Drop Him

Newsweek | Nov 03, 2008

I sometimes say things that I later regret. We all behave differently with our kids when we think no one is watching.

I Had A 'Legitimate Cancer'

Newsweek | Oct 27, 2008

Sometimes—if you listen to your mother and the people you grew up with—you can go home again.

Madonna & Guy: Swept Away

Newsweek | Oct 27, 2008

The crumbling of Madonna and filmmaker Guy Ritchie's marriage isn't entirely surprising—long before the rumors, she herself said the couple's stubborn personalities drew them together in the first place.

A Viewer's Guide to Beijing

Newsweek | Aug 04, 2008

THE HOT RIVALRY The U.S.-China Gold Rush: Get Out Your Abacus From its inception, Beijing 2008 was ballyhooed as a nation's coming-out party, one that would presage the Chinese Century.

Travel: A Munich Milestone

Newsweek | Jul 21, 2008

This is the summer to visit Munich, as the dynamic metropolis celebrates its 850th birthday with two citywide parties.

Last American (Wireless) Virgin

Newsweek | Jul 21, 2008

Phones aimed at kids allow parents to set limits on texts, turn off the device during school hours or block calls from bullies.

Travel: Beijing Bound

Newsweek | Jul 14, 2008

Luxury hotels are redrawing Beijing's skyline as the city prepares to welcome the world to the 2008 Olympic Games.

The Other Contest: Who Will Be Iran's Next President?

Newsweek | Jul 14, 2008

Less than six months after the next American president takes office, Iran will hold its own Election Day.

[View more](#)

MY WIRE

My Channels

MANAGE

 Create a Channel

[What is this?](#)

 My Tools

 My Profile/Account

RECOMMENDATIONS

Get Personalized Recommendations.

[Register](#) (It's free)

PREMIUM ARTICLES

[Lessons in Leadership: Yuriko Koike, Former Cabinet Minister, Japan](#)  Newsweek

[Lessons From the Front Lines](#)  Newsweek

[Lessons in Leadership: Dalia Itzik, Speaker of the Knesset, Israel](#)  Newsweek

[Dell Shifts Gears](#)  Newsweek

[Lessons in Leadership: Zaha Hadid, Architect](#)  Newsweek

[view all premium](#)

[Learn about Premium Access](#)

MYWIRE

- [About MyWire](#)
- [Management](#)
- [Careers](#)
- [Contact Info](#)

MYWIRE SMARTSERVICES

- [About SmartServices](#)
- [SmartMatch](#)
- [SmartTraffic](#)

CUSTOMER SUPPORT

- [FAQ](#)
- [Terms of Use](#)
- [DMCA Guidelines](#)
- [Your Privacy](#)

SHAPE YOUR SERVICE

- [Subscribe](#)
- [Register \(Free\)](#)
- [RSS](#)

• ALL RIGHTS RESERVED

"IN THE NAME OF ONE GOD, THE MOST BENEFICENT,
THE MOST MERCIFUL" "TRUST THE BEST"



Rizubi Trading Used Cars

Japanese Used Cars Exporters & Auctions Member

[English](#)
[日本語版](#)
[عربي](#)
[Stock In Japan](#)
[Stock In UAE](#)
[Stock In Pakistan](#)

Welcome to

Rizubi Trading Used Cars & Construction Equipments Online Showroom, Cars Dismantle Services also available

We believe in your satisfaction

RIZUBI TRADING USED CARS is one of the leading automobile trading company in Japan. We are exporters and auctions member of new/ used motor vehicles and equipment from Japan to all over the world. We have also Agent offices in Dubai / Sharjah United Arab Emirates & Karachi Pakistan.

We offer high quality vehicles, competitive prices and prompt services. Through innovation and export experience since 1991, our company is shaping the new face of the export/import industry of used and new vehicles.

In our **Stock**, we have always different types of Left & Right Hand Drive vehicles, please check our **Stock List**, and advise with your comments. In our Auction Site you can find hundreds of used vehicles from various Auctions in Japan to choose best vehicle of your requirement. For You ! We can find New and Used Japanese Cars, Sports Cars, Vans, Wagons, Buses, Trucks, Commercial Vehicles of any make and model like Toyota, Honda, Nissan, Mitsubishi, Mazda, Suzuki, Isuzu, Hino, Subaru, Daihatsu, Forklift, Excavator, Machinery, Benz, BMW, Chevorlette Etc.



Please Use ID: **W34707**



Please Use ID: **V12647**

- » [Home](#)
- » [Bank Details](#)
- » [Our Stock List](#)
- » [Used Cars & Equipment Auctions](#)
- » [Stock In UAE](#)
- » [Think & Act](#)
- » [Saudi Arabia Business & Cutlure](#)
- » [Guide To Japan](#)
- » [UAE Culture](#)
- » [Contact Us](#)
- » [Advertise With Us](#)

Translate In

- » [Русско](#)
- » [Deutsch](#)
- » [Español](#)
- » [Français](#)
- » [Italiano](#)
- » [Portuguese](#)
- » [English](#)

Buy Used Cars From

- » [Asia](#)
- » [Europe](#)
- » [Africa](#)
- » [U.S.A](#)
- » [Oceana](#)

Japan Office

RIZUBI TRADING USED CARS

7103 Kaburagi Mansion, Nishi Nakanobu,

3-2-17, Shinagawa-Ku, Tokyo 142-0054, Japan [[map](#)]

For Arabic Language Call Tel: 971-50-5393142

Tel: 81-3-3784-9644, Fax: 81-3-3784-5681, Mobile: 81-90-3212-5808

[Send Us Email](#)

Dubai Agent

AL RIZVI MOTORS

P.O Box 63328,

Showroom No. 239,

Awir, Dubai, UAE [[map](#)]

Tel : 81-3-3784-9644

Fax : 81-3-3784-5681

Mobile : 971-50-4626591

: 971-50-5393142 (For Arabic)

[Send Us Email](#)

Sharjah Agent

AL RIZVI USED CARS

P.O.Box 31049, Sharjah, UAE [[map](#)]

Tel : 81-3-3784-9644

Fax : 81-3-3784-5681

Mobile : 971-50-4626591

: 971-50-5393142 (For Arabic)

[Send Us Email](#)

Pakistan Agent

ALL FAMILY MOTORS

Hyderabad Pakistan

Tel : 92-301-2586644

[Send Us Email](#)

Other Links

» [Muslim Holy Al-Qur'an](#)

» [Jesus Christ Holy Bible](#)

You Are Visitor No.

1297699

Free Counters



Tokyo Metropolitan Public Safety Commission Permit Number 302189102978

[Home](#) | [Our Stock List](#) | [Used Cars & Equipment Auctions](#) | [Stock In UAE](#) | [Think & Act](#) | [Contact Us](#)

Copyrights © Rizubi.com

Welcome to
globalcoolingjapan.com

Related Searches: [Stirling Motor](#) [Stirling Engines](#) [Stirling](#) [Hot Air Engine](#)

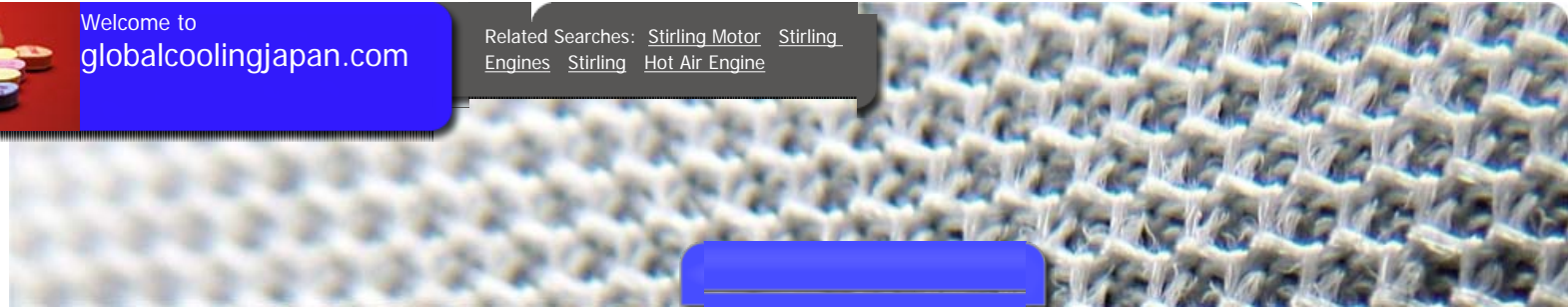

[Buy this Domain](#)

Sponsored Listings for Stirling Motor

• [Stirling Motor](#)
➔ [Hotels in Stirling](#)

Compare hotels and save up to 75%! Save time, book at Booking.com

www.booking.com/Hotels-Stirling

• [Stirling Engines](#)

➔ [Stirling Engine](#)

supplier of models as educational tools for schools and collectors

www.stirlingshop.de

• [Hot Air Engine](#)

• [Stirling Energy](#)
➔ [Stirling](#)

Know Before You Go. Read Reviews from Real Travelers.

www.TripAdvisor.com

• [Hotel In Stirling](#)

• [Stirling United](#)
➔ [B&Bs in Stirling](#)

Late Deals on Hotels and B&Bs. Up to 70% off. Book Online & Save!

www.LateRooms.com

• [Subaru Engine](#)

• [Car Engine](#)
➔ [147' Sterling For Sale](#)

Compare 2008. Magnificent View in Monaco, Crew Standing By!

SuperYachtsToyStore.com

• [Reconditioned](#)

➔ [Qdrive Cryocoolers](#)

Acoustic Stirling (Pulse-Tube) Cryocoolers from 8W-1kW at 77K.

www.qdrive.com

• [Hot Air Engine](#)

➔ [Sterling bearings](#)

AWD, China Professional Factory Supply Various Bearing Balls

WD-Bearing.Com

➔ [Revere Bowls](#)

Sterling, Pewter & Silverplated Custom Engraved - Fast Service

www.radersengraving.com

 [Veit Profi Dampfgenerator](#)

Elektro-Dampferzeuger von 2,2-60 KW Made in Germany + D-weiter Service

www.veit.de

 [The Low Carbon Economy](#)

Connect with low carbon products, services, information,opportunities

www.LowCarbonEconomy.com

Welcome to
globalcoolingjapan.com

Related Searches: [Stirling Motor](#) [Stirling Engines](#) [Stirling](#) [Hot Air Engine](#)

[Buy this Domain](#)

Sponsored Listings for Stirling Engines

• [Stirling Motor](#)
▶ [Hotels in Stirling](#)

Compare hotels and save up to 75%! Save time, book at Booking.com

www.booking.com/Hotels-Stirling

• [Stirling Engines](#)

▶ [Stirling Engine](#)

supplier of models as educational tools for schools and collectors

www.stirlingshop.de

• [Hot Air Engine](#)

• [How To Make](#)
▶ [Qdrive Cryocoolers](#)

Acoustic Stirling (Pulse-Tube) Cryocoolers from 8W-1kW at 77K.

www.qdrive.com

• [Stirling Energy](#)

▶ [Stirling engine](#)

Get the Scoop from Travelers Who Know Stirling!

www.TravelAdvisor.com

• [Gas Engines](#)

• [Combined Heat](#)
▶ [B&Bs in Stirling](#)

Late Deals on Hotels and B&Bs. Up to 70% off. Book Online & Save!

www.LateDeals.com

• [Gas Engines](#)

• [Subaru Engine](#)
▶ [Sterling bearings](#)

AWD, China Professional Factory Supply Various Bearing Balls

WD-Bearing.Com

• [China Engine](#)

▶ [The Low Carbon Economy](#)

Connect with low carbon products, services, information,opportunities

www.LowCarbonEconomy.com

▶ [Zenoah Engines and Parts](#)



Zenoah engines, plus thousands of stock and aftermarket parts.

www.davesmotors.com

 [Cogeneration - CHP](#)

Cummins Power Generation can build, and operate turnkey CHP systems.

www.cumminspower.com/cogeneration

 [Plastem - plastic piston](#)

article de pot textile piston Suroy spinning can product slider bumper

www.plastem.com/pistons_suroy.html

Welcome to
globalcoolingjapan.com

Related Searches: [Stirling Motor](#) [Stirling Engines](#) [Stirling](#) [Stirling Scotland](#)

[Buy this Domain](#)

Sponsored Listings for Stirling

• [Stirling Motor](#)
[Hotels in Stirling](#)

Book a hotel in Stirling online. No reservation costs. Great rates!

www.booking.com/Stirling-Scotland

• [Stirling Engines](#)

• [Stirling](#)
[Stirling](#)

Get the Scoop from Travelers Who Know Stirling!

www.TripAdvisor.com

• [Stirling Hotel](#)

• [Stirling Energy](#)
[B&Bs in Stirling](#)

Late Deals on Hotels and B&Bs. Up to 70% off. Book Online & Save!

www.LateRooms.com

• [Stirling United](#)

• [Stirling Liens](#)
[Stirling Engine](#)

supplier of models as educational tools for schools and collectors

www.stirlingshop.de

• [Stirling](#)

• [Stirling Loud](#)
[Qdrive Cryocoolers](#)

Acoustic Stirling (Pulse-Tube) Cryocoolers from 8W-1kW at 77K.

www.stirlingloud.com

• [Stirling Tourism](#)

• [Stirling houses](#)
[Stirling Accommodation](#)

B&Bs, guest houses, hotels Online Reservations 365 Days

www.scottishaccommodationindex.com

• [Stirling NJ](#)
[Apartments with Rent.com](#)

Search Stirling NJ apartments Report your lease and get \$100.

www.Rent.com

• [Stirling](#)
[Map of Stirling Hotels](#)

Stirling Hotels and Attractions. Reserve today, pay on departure.

www.somewheretogo.co.uk

 [The Low Carbon Economy](#)

Connect with low carbon products, services, information, opportunities

www.LowCarbonEconomy.com

 [Scottish Gifts](#)

Huge selection of gifts from Scotland. Free shipping.

www.scotwebstore.com

Welcome to
globalcoolingjapan.com

Related Searches: [Stirling Motor](#) [Stirling Engines](#) [Stirling](#) [Global Warming Kyoto Protocol](#)

[Buy this Domain](#)

Sponsored Listings for Kyoto Global Warming

- [Stirling Motor](#)

➔ [Global Warming Myth](#)
 Facts and News Articles About Climate Change & Global Warming
www.FT.com/climate
 - [Stirling Engines](#)
- [Global Warming](#)

➔ [No Global Warming](#)
 No significant warming since 1995 Read in Facts & Arts
www.factsandarts.com
 - [Global Warming](#)
- [Kyoto Temperature](#)

➔ [Kyoto Temperature](#)
 Know Before You Go. Read Reviews from Real Travelers.
www.TripAdvisor.com
 - [Global Warming](#)
- [Global Warming?](#)

➔ [Global Warming?](#)
 What is the Christian view on Global Warming? Read now.
ChristianityToday.com/ct
 - [Climate Change](#)
- [Climate Change MediaWatch](#)

➔ [Climate Change MediaWatch](#)
 Weekly Updates on News Coverage Trends, Analyses & Visualizations
www.ecoresearch.net/climate
 - [Greenhouse](#)
- [Greener aviation](#)

➔ [Greener aviation](#)
 Find out what the aviation industry is doing
www.Enviro.aero
 - [Global Warming](#)
- [Global Warming For Kids](#)

➔ [Global Warming For Kids](#)
 Learn How to Stop Global Warming w/ Cool Games, Books & More. Visit us!
www.GlobalWarmingKids.net
 - [Global Warming](#)
- [Carbon Markets Africa](#)

➔ [Carbon Markets Africa](#)

Voluntary Carbon Markets & Forestry Opportunities in Africa

www.GreenPowerConferences.com

 [Effects of global warming](#)

A Complete Academic Resource 384 Pages of Related Content

BookRags.com

 [Greenhouse Certificate](#)

Online Courses On GHG Accounting. Earn a Certificate. Sign Up Now!

www.GHGInstitute.org

Welcome to
globalcoolingjapan.com

Related Searches: [Stirling Motor](#) [Stirling Engines](#) [Stirling](#) [Tourist Japan](#)



[Buy this Domain](#)

Sponsored Listings for Japan Video

- [Stirling Motor](#)

➔ [Executive Apartment Tokyo](#)
 Owner of 2100 exclusive apartments in the heart of Tokyo. No agent fee
www.sumitomo-latour.jp
 - [Stirling Engines](#)
- [Stirling](#)

➔ [Japan](#)
 Visiting Japan? Find Deals & Read Hotel Reviews!
www.TripAdvisor.com
 - [Tourist Japan](#)
- [Japan Girls](#)

➔ [Outdoor Travel Japan](#)
 • [Japan Roommate](#)
 Ski & Adventure Holidays All Season Discount Packages and tours NOW
www.outdoortraveljapan.com
 - [Hiroshima Japan](#)
- [Saitama Japan](#)

➔ [Japanese tea](#)
 All about the Japanese tea culture The best teas of Marukyu Koyamaen
japantea.hu
 - [Japan Railways](#)
- [Japan Sexy](#)

➔ [100% Sexy](#)
 • [Japan Roommate](#)
 See Sexy Beyonce Photos! Vibe.com - the Home of Hip Hop
www.Vibe.com/galleries/
 - [Yokohama Japan](#)
- [Japan Women](#)

➔ [Japanese Golf Club Sale](#)
 Every Japanese golf brand is Here! All on Sale. Lowest prices Ever
www.toursspecgolf.com/proshop
- ➔ [Japan Business News](#)
 Get major business news of Japanese companies.
www.teikoku.com
- ➔ [Wife Leave](#)

Learn to Be Nice to Your Wife, or Pay the Price. Read Full Story.

www.washingtonpost.com

 [Rizubi Used Cars Japan](#)

Used Cars Exporter, Auction Agent Japan Used Cars & Const.Equipment

www.rizubi.com

 [Furano Skifront Apartment](#)

Ski Legendary Hokkaido Powder. Ideal location 30 m from Gondola.

www.freshpowder.com

Welcome to
globalcoolingjapan.com

Related Searches: [Stirling Motor](#) [Stirling Engines](#) [Stirling](#) [Acid Rain And Global Warming](#)

[Buy this Domain](#)

Sponsored Listings for Global Warming And Acid Rain

- [Stirling Motor](#)

➔ [Global Warming Effects](#)

Facts & News Stories Surrounding Today's Most Important Global Issue

[www.FT.com/climate](#)

 - [Stirling Engines](#)
- ➔ [No Global Warming](#)

No significant warming since 1995 Read in Facts & Arts

[www.factsandarts.com](#)

 - [Acid Rain And](#)
- ➔ [Global Warming?](#)

What is the Christian view on Global Warming? Read now.

[ChristianityToday.com/ct](#)

 - [Global Warming](#)
- ➔ [Plexus Online Software](#)

For Discrete World Six Sigma, CAPA, PPAP, APQP, Poka-Yoke & More

[www.Plex.com/Quality](#)

 - [Global Warming](#)
- ➔ [Aviation and environment](#)

Industry and innovation, news and issues.

[www.Enviro.aero](#)

 - [Co2](#)
- ➔ [Climate Change MediaWatch](#)

Weekly Updates on News Coverage Trends, Analyses & Visualizations

[www.ecoresearch.net/climate](#)

 - [Global](#)
- ➔ [Free Selection Guide](#)

Mobile dehumidifiers for water damage restoration

[www.dantherm-air-handling.com](#)

 - [Acid Rain And](#)
- ➔ [Carbon Markets Africa](#)



How Clean Development Mechanism aid African emission reduction projects

www.GreenPowerConferences.com

 [Global Warming For Kids](#)

Learn How to Stop Global Warming w/ Cool Games, Books & More. Visit us!

www.GlobalWarmingKids.net

 [Fix Your Damaged Heart](#)

Your Stem Cells Can Fix Your Heart! A Finer Quality of Life is Possible

www.vescell.com/adult-stem-cells

Welcome to
globalcoolingjapan.com

Related Searches: [Stirling Motor](#) [Stirling Engines](#) [Stirling](#) [Effects Of Global Warming](#) [Info](#)

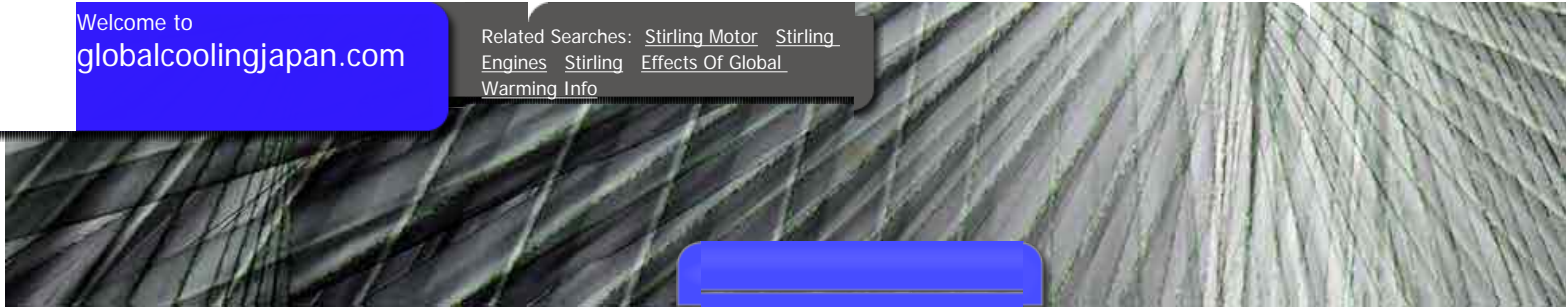

[Buy this Domain](#)

Sponsored Listings for The History Of Global Warming

- [Stirling Motor](#)
[Global Warming Effects](#)
 Facts & News Stories Surrounding Today's Most Important Global Issue
www.FT.com/climate
 • [Stirling Engines](#)
- [Global Warming](#)
[No Global Warming](#)
 No significant warming since 1995 Read in Facts & Arts
www.factsandarts.com
 • [Effects Of Global](#)
- [Global Warming?](#)
[Global Warming?](#)
 What is the Christian view on Global Warming? Read now.
ChristianityToday.com/ct
 • [Global Warming](#)
- [Greenhouse](#)
[Aircraft emissions](#)
 70 % reduction in 40 years, where next?
www.Enviro.aero
- [Black History](#)
[Climate Change MediaWatch](#)
 Weekly Updates on News Coverage Trends, Analyses & Visualizations
www.ecoresearch.net/climate
 • [History of](#)
- [Medieval History](#)
[Effects of global warming](#)
 A Complete Academic Resource 384 Pages of Related Content
BookRags.com
 • [American History](#)
- [Medieval History](#)
[Kids Global Warming Site](#)
 We Have Fun Kids Links For Global Warming Causes & Effects. Visit us!
www.GlobalWarmingKids.net
- [As Seen on O's Show](#)

Wrinkles gone in 60 seconds! The product that got a 5-Star Rating.

www.dremu.com/Oprah

 [History Of Jesus](#)

Read Or Watch The Video Of The Story Of Jesus Christ. Visit Now!

www.JesusCentral.com

 [Carbon Markets Africa](#)

Carbon Finance – How To Expand Investment in the CDM in Africa.

www.GreenPowerConferences.com

Welcome to
globalcoolingjapan.com

Related Searches: [Stirling Motor](#) [Stirling Engines](#) [Stirling](#) [Sea Level Rise](#) [Climate Change](#)

[Buy this Domain](#)

Sponsored Listings for [Glaciers Melting Due To Global Warming](#)

• [Stirling Motor](#)
➡ [Glacier Global Warming](#)

Facts and News Articles About Climate Change & Global Warming

• [www.FT.com/climate](#)
• [Stirling Engines](#)

➡ [No Global Warming](#)

No significant warming since 1995 Read in Facts & Arts

• [Sea Level Rise](#)
[www.factsandarts.com](#)

➡ [Global Warming?](#)

What is the Christian view on Global Warming? Read now.

• [ChristianityToday.com/ct](#)
• [Glaciers Global](#)

➡ [Greener aviation](#)

Find out what the aviation industry is doing

• [www.Enviro.aero](#)
• [Melting Ice](#)

➡ [Icy Cools - Made in USA](#)

Reusable Cubes, Mats, Snakes Innovating Hot/Cold for 10 Years

• [www.Greencold.com](#)

➡ [Tilting Crucible Furnace](#)

Automatic Tilting Crucible Furnace For Melts Up To 1300C

• [www.flamefast.co.uk/heat-treatment](#)
• [Global Warming](#)

➡ [Climate Change MediaWatch](#)

Weekly Updates on News Coverage Trends, Analyses & Visualizations

• [www.ecoresearch.net/climate](#)

➡ [Global Climate Change](#)

For students, schools, teachers. Science Museums. Portal website.

www.climatechangeeducation.org

 [Greenhouse Certificate](#)

Online Courses On GHG Accounting. Earn a Certificate. Sign Up Now!

www.GHGInstitute.org

 [Ovulation Calculator](#)

Charts & Calendars To Predict Your Ovulation, Signs, Symptoms & More

www.FitPregnancy.com

Welcome to
globalcoolingjapan.com

Related Searches: [Stirling Motor](#) [Stirling Engines](#) [Stirling](#) [Icebergs Melting](#)

[Buy this Domain](#)

Sponsored Listings for Melting Ice Age

• [Stirling Motor](#)
➔ [Melting Ice Age](#)

Facts & News Stories Surrounding Today's Most Important Global Issue

[www.ft.com/climate](#)
• [Stirling Engines](#)

➔ [Hannah McKeand](#)

Polar explorer, guide, speaker. Antarctica and the Arctic

• [Icebergs Melting](#)
[www.hannahmckeand.com](#)

• [Sea Level Rise](#)
➔ [Icy Cools - Made in USA](#)

Reusable Cubes, Mats, Snakes Innovating Hot/Cold for 10 Years

• [Melting Ice](#)
[www.icycools.com](#)

• [Melting Glaciers](#)
➔ [Tilting Crucible Furnace](#)

Automatic Tilting Crucible Furnace For Melts Up To 1300C

• [Greenland](#)
[www.flamefast.co.uk/heat-treatment](#)

• [Antarctic Melting](#)
➔ [Cerro Alloys and HTA](#)

We supply and sell Cerro Alloys Made in America for the world

• [Japan](#)
[www.hitechalloys.com](#)
• [North Pole](#)

➔ [industrial microwave](#)

industrial microwave manufacturers competitive price

• [China](#)
[www.ccare.cn](#)

➔ [Induction Heating Machine](#)

Leading manufacturer and supplier. Value, quality and service.

[www.wvchina.com](#)

➔ [Ice Rinks](#)

Europes leading manufacturer of temporary and permanent ice rinks!

www.ast.at

 [Merckens Chocolate](#)

Merckens Chocolate Melting Wafers Delicious and so easy to use.

www.CustomChocolateShop.com

 [Agarose Electrophoresis](#)

DNA / RNA Electrophoresis Products Agaroses, Buffers, Markers, Stains

www.nbsbio.co.uk

Welcome to
globalcoolingjapan.com

Related Searches: [Stirling Motor](#) [Stirling Engines](#) [Stirling](#) [Sea Level Rise](#) [Climate Change](#)

[Buy this Domain](#)

Sponsored Listings for Arctic Warming

• [Stirling Motor](#)
➡ [Glacier Global Warming](#)

Facts and News Articles About Climate Change & Global Warming

[www.FT.com/climate](#)

• [Stirling Engines](#)

➡ [No Global Warming](#)

No significant warming since 1995 Read in Facts & Arts

[www.factsandarts.com](#)

➡ [Hannah McKeand](#)

Polar explorer, guide, speaker. Antarctica and the Arctic

[www.hannahmckeand.com](#)

• [Arctic Ice](#)

➡ [Stern Report](#)

The Economics of Climate Change Browse 100,000+ environment books

[www.nhbs.com](#)

• [Glaciers Global](#)

➡ [Aviation and environment](#)

Industry and innovation, news and issues.

[www.Enviro.aero](#)

• [Arctic Science](#)

➡ [Climate Change MediaWatch](#)

Weekly Updates on News Coverage Trends, Analyses & Visualizations

[www.GlobalWarming.net/climate](#)

➡ [Global Climate Change](#)

For students, schools, teachers. Science Museums. Portal website.

[www.climatechangeeducation.org](#)

➡ [Icy Cools - Made in USA](#)

Reusable Cubes, Mats, Snakes Innovating Hot/Cold for 10 Years

www.icycools.com

 [Global Warming?](#)

What is the Christian view on Global Warming? Read now.

ChristianityToday.com/ct

 [Arctic Challenge Videos](#)

Home of the exclusive webcast, competition & post-event highlights

www.go211.com

Welcome to
globalcoolingjapan.com

Related Searches: [Stirling Motor](#) [Stirling Engines](#) [Stirling](#) [Sea Level Rise](#) [Climate Change](#)

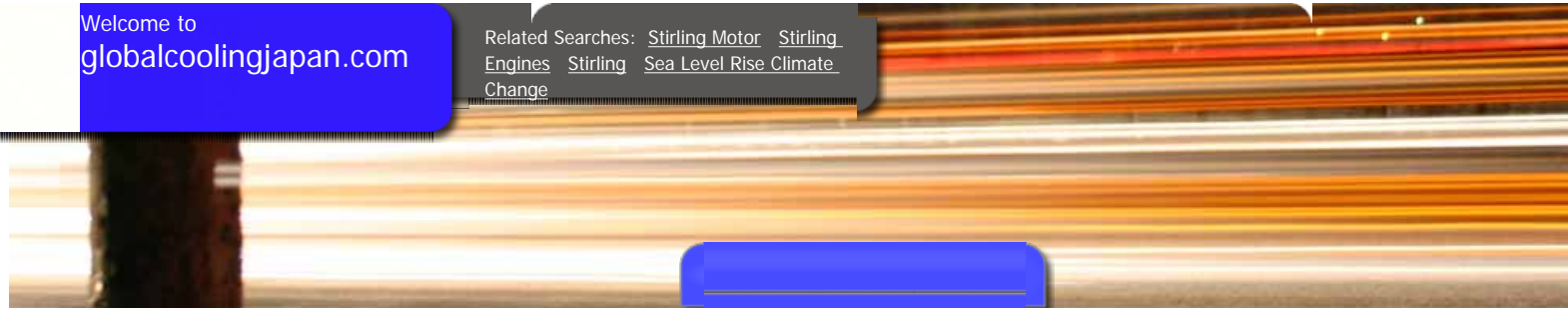

[Buy this Domain](#)

Sponsored Listings for Arctic Temperature

• [Stirling Motor](#)
➔ [Sea Temperature](#)

Facts & News Stories Surrounding Today's Most Important Global Issue

[www.ft.com/climate](#)
• [Stirling Engines](#)

➔ [Environmental Chambers](#)

New & Used Test Chambers Service, Rent & Lease, Lab Services

• [Sea Level Rise](#)
[www.wi-ii.com](#)

➔ [Temporal Thermometer](#)

Accurate temperature with a gentle forehead scan. Doctor recommended.

[www.exergen.com](#)
• [Arctic](#)

➔ [EMSL Analytical, Inc.](#)

Moisture Meters - Inspection Tools Infrared Cam (888) 958-8170

[www.emsl.com](#)
• [Global Warming](#)

➔ [TCXO Crystal Oscillators](#)

High perform. Hi-Rel OCXO, TCXO, SMD VCXO & SMD XO oscillators

• [Arctic Sea Ice](#)
[www.bliley.com](#)
• [Global Warming](#)

➔ [Hannah McKeand](#)

Polar explorer, guide, speaker. Antarctica and the Arctic

• [Arctic Melt](#)
[www.hannahmckeand.com](#)

➔ [Temperature](#)

Free Tool from The Weather Channel Temps, Alerts, News, Traffic & More

[www.weather.com/desktop](#)

➔ [Icy Cools - Made in USA](#)



xperts

Reusable Cubes, Mats, Snakes Innovating Hot/Cold for 10 Years

www.icycools.com

 [Light Measurement Systems](#)

LED, Laser and Sunlight UV-VIS-NIR Ranges 200-2300nm

www.StellarNet.us

 [AdTech Ceramics](#)

Custom Hi Rel multi layer ceramic packages in HTCC, AlN and LTCC

www.AdTechCeramics.com

Welcome to
globalcoolingjapan.com

Related Searches: [Stirling Motor](#) [Stirling Engines](#) [Stirling](#) [Solar Radiation](#)

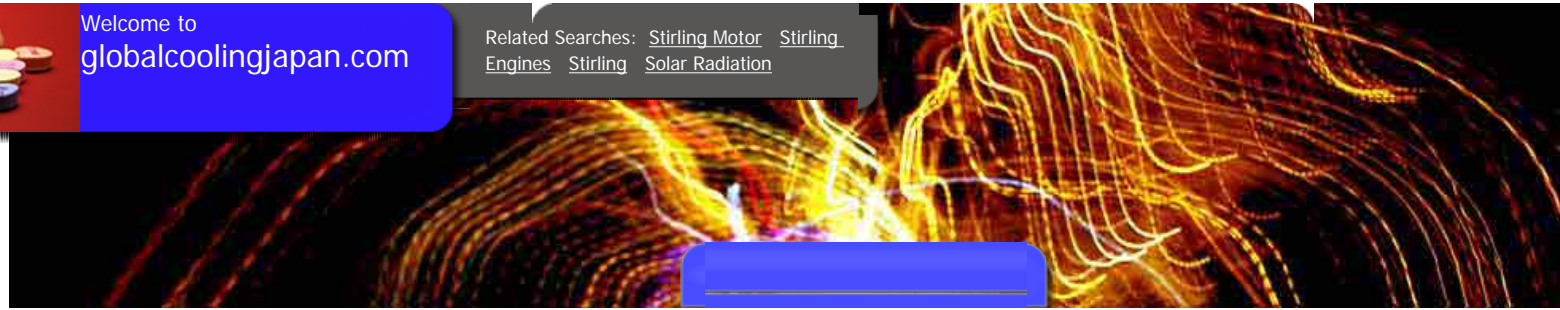

[Buy this Domain](#)

Sponsored Listings for Albedo Effect

- [Stirling Motor](#)

➔ [Albedo Effect](#)
 Facts & News Stories Surrounding Today's Most Important Global Issue
www.FT.com/climate
 - [Stirling Engines](#)
- [Stirling](#)

➔ [METEONORM](#)
 Global meteorological database for Engineers, Planners and Education
www.meteonorm.com
 - [Solar Radiation](#)
- [Sea Level Rise](#)

➔ [Light Measurement Systems](#)
 LED, Laser and Sunlight UV-VIS-NIR Ranges 200-2300nm
www.StellarNet.us
 - [Solar Irradiance](#)
- [Global Warming](#)

➔ [Solar Radiation Sensors](#)
 Pyranometers and Dataloggers UVA, UVB, UVA+UVB spectrums
www.SolarLight.com
 - [Global Radiation](#)
- [Arctic](#)

➔ [WLAN Solar Inselsysteme](#)
 WLAN System mit autonomer Energie- versorgung Solar + Windkraft
www.MikroTik-Store.eu
 - [Causes Global](#)
- [Global Shortwave](#)

➔ [Net Radiometer](#)
 Separable shortwave and longwave Compact, rugged, lightweight design
www.apogee-inst.com
- ➔ [Make Solar And Wind Power](#)
 How Much Are You Set To Save? 100% Guarantee Read Now
www.earth4energy.com/
- ➔ [No Global Warming](#)

No significant warming since 1995 Read in Facts & Arts

www.factsandarts.com

 [Renewable Energy](#)

Products, News, Information Jobs, Services, Opportunities

www.LowCarbonEconomy.com

 [DAV-6450 Solar Sensor](#)

Davis VP Solar Radiation Sensor From the Vantage Pro Experts!

www.skyview.co.uk/davis

TourSpecGolf - your all inclusive golf connection



- [Home](#)
- [Pro Shop](#)
- [Forums](#)
- [Gallery](#)
- [Videos](#)
- [About TSG](#)

[NEW PRODUCTS](#)

[SALE ITEMS](#)

[BEST SELLERS](#)

[CUSTOMIZABLE GEAR](#)

[RARE & LIMITED](#)

[NEED HELP?](#)

[REGISTER](#)

- ➔ TSG PARTNERS
- > EPON JAPAN FORGED
- > GOLD'S FACTORY
- > GEORGE SPIRITS
- > GEOTECH GOLF COMPONENTS

- ➔ BROWSE
- > DRIVERS
- > FAIRWAY WOODS/UTILITES
- > IRON SETS
- > WEDGES
- > PUTTERS
- > COMPONENTS
- > LEFT-HANDED
- > LADIES
- > SHAFTS AND GRIPS
- > ACCESSORIES
- > APPAREL

🔍 PRODUCT SEARCH

[Advanced search](#)

➔ GOLF JAPAN BY BRAND

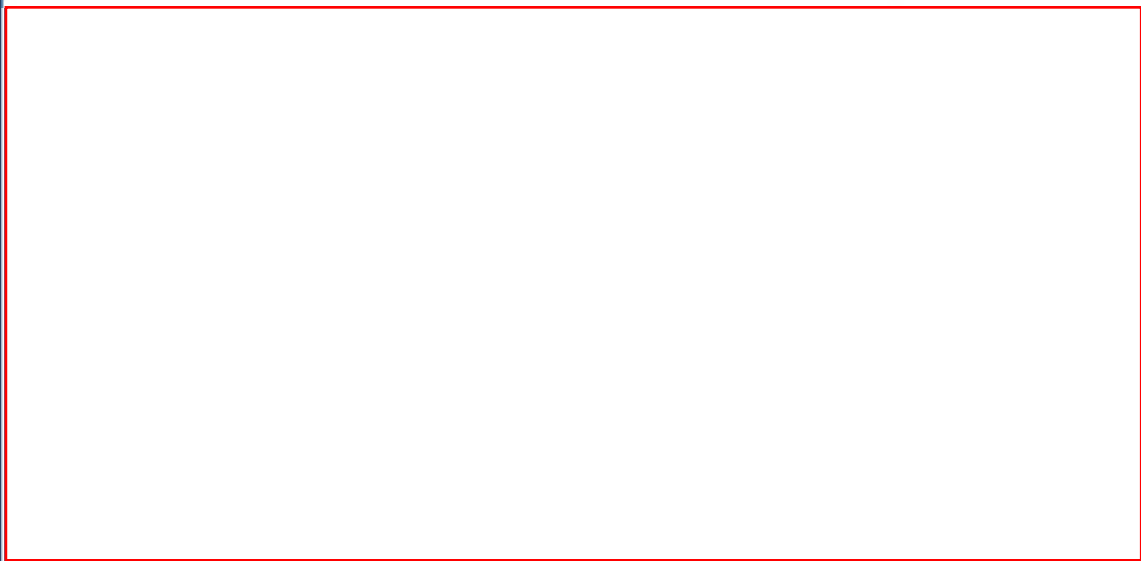

EPON FORGED JAPAN
PREMIUM FORGED GOLF CLUBS FROM ENDO JAPAN



[View More](#)

GOLD'S FACTORY
UNIQUE MASTERPIECES CUSTOMIZED FOR YOUR GAME



[View More](#)

🛒 SHOPPING CART

Total Items: 0
Total Price: \$0.00

[CHECKOUT](#) [VIEW CART](#)

ControlScan™

CONTROLSCAN REGISTERED MEMBER 

BUSINESS BACKGROUND REVIEWED 

Internet Security By ControlScan

VERIFIED 30-OCT

→ YOUR J-SPEC SOURCE



Tourspecgolf's online pro shop is the number one English source for Japanese golf clubs and high end golf gear on the internet. As fellow equipment junkies and enthusiasts of the game of golf, we strive to make the best golf gear in Japan available to customers worldwide.



From high end shafts like Daiwa Roddio Pentacross and Diamana special edition all'islei to rare sets of irons like ONOFF's CB-247 or Miura Giken's Miuraism line, we can get it for you. At TSG we work hard to provide customers with the honest information they need to make a good purchase to match their budget and game.



All our products are 100% authentic, come directly from Japan and are high quality and visually stunning, made from the best materials, strict manufacturing processes and world class workmanship. Brands like Epon, Tourstage, Srixon, Fourteen, Mizuno, Honma, Yamaha, Taylormade Japan and many others will make you stand out from the crowd. [Tourspecgolf - Golf to Impress!](#)

GEORGE SPIRITS
DESIGNED FOR THE ATHLETE GOLFER BY GEORGE TAKEI

▶ View More

GEOTECH GOLF COMPONENTS
AMAZING PERFORMANCE AND VALUE FROM JAPAN

▶ View More

Callaway Japan 2009 Legacy Forged Iron 5



Callaway Japan

introduces their all new Legacy Forged iron for 2009! The Legacy design was supervised by Roger Cleveland specifica...

MSRP:
\$1,260.00 **\$1,140.00**

▶ More info

Roddio Tricross W-5EX W/ Installation



Roddio is a

subsidiary of Daiwa Golf Japan. Tricross is a multi-axial carbon weave made to minimize vibrations whi...

MSRP:
\$399.00

▶ More info

Mach Line Premium Shafts

NGS



introduces their all new Mach Line Premium shaft. The Mach Line premium is a light weight low torque shaft aimed at control an...

MSRP:

\$315.00 **\$275.00**

[▶ More info](#)

Mach Line e Driver Shafts

NGS



introduces their new Mach Line e driver shafts. Designed for the smooth swinger looking for a forgiving shaft that squares to ...

MSRP:

\$275.00 **\$249.00**

[▶ More info](#)

Mach Line e FW Shafts

NGS



introduces their new Mach Line e FW shafts. Designed for the smooth swinger looking for a forgiving shaft that squares to...

MSRP:

\$195.00 **\$175.00**

[▶ More info](#)

Como!Come! 2009 Standard Caddy Bag

Como!
Come!



introduces their all new Standard Caddy bag for the 2009 season. The new Standard Bag weighing 4.2kg and is m...

MSRP:

\$367.50

[▶ More info](#)

Como!Come! Ladies Knit Half Sleeve Shirt



Como!
Come!'s
new
2008-
2009
Winter
Lineup
includes
new top

quality golf knit wear. The ladies Knit Half Sleeve shirt is made of...

MSRP:
\$142.50

[More info](#)

Como!Come! Ladies Knit Mini Skirt



Como!
Come!'s
new
2008-
2009
Winter
Lineup
includes
new top

quality golf knit wear. The ladies Knit Mini Skirt is made of 100% W...

MSRP:
\$189.00

[More info](#)

Como!Come! Ladies Knit High Neck Border



Como!
Come!'s
new
2008-
2009
Winter
Lineup

includes new top quality golf knit wear. The ladies Knit High Neck Border shirt is ma...

MSRP:
\$189.00

[More info](#)

Como!Come! Ladies Knit Half Sleeve Parka



Como!
Come!'s
new
2008-
2009
Winter
Lineup

includes new top quality golf knit wear. The ladies Half Sleeve Knit Parka is ma...

MSRP:
\$247.50

[More info](#)

Como!Come! Men's Knit Half Sleeve Shi



Como!
Come!'s
new
2008-
2009
Winter
Lineup
includes
new top

quality golf knit wear. The men's
Half Sleeve Knit Shirt is made...

MSRP:
\$157.50

[▶ More info](#)

Como!Come! Men's Knit 2 Way Zip Jacke



Como!
Come!'s
new
2008-
2009
Winter
Lineup

includes new top quality golf knit
wear. The men's 2 Way Zip Up
Jacket is made of...

MSRP:
\$285.00

[▶ More info](#)

Gold's Factory USA Limited G Wedge Se



The
Gold's
Factory
USA G
Wedge
is based
on the
GF
Original

Forged Wedge, a unqiue design
created by Master Sasaya. The sole
of...

MSRP:
\$1,500.00

[▶ More info](#)

Gold's Factory USA Limited Hearts Pro



The
Gold's
Factory
USA
Hearts

Prototype Wedge is based on the
GF Original Forged Wedge, a
unqiue design created by Master
Sasa...

MSRP:
\$1,600.00

[▶ More info](#)

Gold's Factory USA Limited Skull Wedg



AUGUST 15TH

UPDATE: SOLD OUT! The Gold's Factory USA Skull Wedge is based on the GF Original Forged Wedge, a unqie desig...

MSRP: \$1,900.00

[More info](#)

Gold's Factory USA Limited Red Fire P



Gold's Factory USA

introduces their Element line of tour putters. The Red Fire putter is based on 2 different Gold's Facto...

MSRP: \$1,975.00

[More info](#)

Gold's Factory USA Limited Blue Ice P



Gold's Factory USA

introduces their Element line of tour putters. The Blue Ice putter is based on 2 different Gold's Facto...

MSRP: \$2,200.00

[More info](#)

Gold's Factory USA Limited Lucky Clov



The Gold's Factory USA Lucky Clover putter is a limited

edition Tour putter based on the Private Stock No.1 model from Gold ...

MSRP: \$1,780.00

[More info](#)

Gold's Factory USA Limited
STEALTH Pu



The Gold's Factory USA Stealth putter is based on the Private

Stock No.2 anser model. Forged from the most expensive S20C stee...

MSRP:
\$2,150.00

[More info](#)

Gold's Factory USA Limited
Independen



The Gold's Factory USA

Independence Tour Putter in Red, White and Blue is based on Gold's Factory's Private Stock No.1...

MSRP:
\$1,680.00

[More info](#)

Tourstage 2009 X-01 B+ Ball
Tourstage



introduces it's all new 2009 X-01 Series ball. The new X-01 was created based on R&D focusing on lower compression i...

MSRP:
\$75.00

[More info](#)

Tourstage 2009 X-01 G+ Ball
Tourstage



introduces it's all new 2009 X-01 Series ball. The new X-01 was created based on R&D focusing on lower compression i...

MSRP:
\$75.00

[More info](#)

Tourstage 2009 X-01 R+ Ball
Tourstage



introduces it's all new 2009 X-01 Series ball. The new X-01 was created based on R&D focusing on lower compression i...

MSRP:
\$75.00

[More info](#)

Ping Japan 2009 Rapture V2 J 5-PW



Ping
Japan

introduces their all new Rapture V2 J iron for 2009! The Rapture V2 J is specifically made for the Japanese m...

MSRP:
\$1,260.00 **\$1,110.00**

[More info](#)

Gold's Factory Handmade Bag Tag



Each
Gold's
Factory
bag tag

is machine milled from 5mm thick aluminum then hand grinded and polished individually to...

MSRP:
\$65.00

[More info](#)

Gold's Factory Sword Oil



Introducing
Sword
Oil
created
by
Gold's
Factory
for

protecting your putters and golf clubs. In ancient Japanese times, Japanes...

MSRP:
\$23.50

[More info](#)

Tourstage 2009 X-Drive 901 Driver
Tourstage has



introduced it's all new X-Drive lineup for 2009! The new lineup consists of 4 all titanium models, the...

MSRP:
\$892.50 **\$769.00**

[▶ More info](#)

Tourstage 2009 X-Drive 701 Driver
Tourstage has



introduced it's all new X-Drive lineup for 2009! The new lineup consists of 4 all titanium models, the...

MSRP:
\$892.50 **\$769.00**

[▶ More info](#)

Tourstage 2009 X-Drive 701G Driver



Tourstage has

introduced it's all new X-Drive lineup for 2009! The new lineup consists of 4 all titanium models, the...

MSRP:
\$892.50 **\$769.00**

[▶ More info](#)

Tourstage 2009 X-Drive GR Driver
Tourstage has



introduced it's all new X-Drive lineup for 2009! The new lineup consists of 4 all titanium models, the...

MSRP:
\$661.50 **\$569.00**

[▶ More info](#)

Tourstage 2009 X-Blade GR P-1 5-PW

Tourstage



introduces the all new X-Blade GR P-1 for 2009. The new GR C-1 is a SUS431 iron with high MOI and a large sweet are...

MSRP:
\$945.00 **\$845.00**

[▶ More info](#)

Tourstage 2009 X-Blade GR C-1 5-PW

Tourstage



introduces the all new X-Blade GR C-1 for 2009. The new GR C-1 is a soft forged iron with high MOI and a large swee...

MSRP:
\$1,070.00 **\$919.00**

[▶ More info](#)

Tourstage 2009 X-Blade 701G CB 5-PW

Tourstage



introduces it's all new 2009 X-Blade 701G cavity back iron. The 701G is a compact CB like the 701 however it also us...

MSRP:
\$1,135.00 **\$975.00**

[▶ More info](#)

Tourstage 2009 X-Blade 701 CB 5-PW

Tourstage



introduces its all new X-Blade 701 for the 2009 season. The X-Blade 701 is a compact premium forged cavity back with min...

MSRP:
\$1,135.00 **\$975.00**

[▶ More info](#)

Tourstage 2009 Limited X-Blade
901 5-PW



The new X-Blade 901 from

Tourstage for 2009 is a compact blade featuring minimal offset and a lower center of gravity focusin...
MSRP:

\$1,197.00 ~~\$1,027.00~~

[More info](#)

Tourstage 2009 X-Wedge 101
Tourstage



introduces it's all new X-Wedge 101 for 2009. The 101 wedge is a compact tear drop shaped wedge with straight neck a...
MSRP:

\$189.00 ~~\$165.00~~

[More info](#)

Tourstage 2009 X-Wedge 102HB
Tourstage's new 2009 X-Wedge 102HB is a larger round shaped



wedge with semi goose neck. It is designed to be "automatic" for i...
MSRP:

\$189.00 ~~\$165.00~~

[More info](#)

Tourstage 2009 901 Limited Pro Spec Wedg
Tourstage



introduces it's all new 2009 Limited Edition 901 Pro Spec Wedge set. This set of wedges comes with two premium ...
MSRP:

\$525.00 ~~\$489.00~~

[More info](#)

Tourstage 2009 X-Drive GR FW
Fairway Woo

Tourstage



introduces their all new 2009 X-Drive GR Fairway wood. The new GR FW is for the better player looking for a shallo...

MSRP:
\$346.50 **\$299.00**

[▶ More info](#)

Tourstage 2009 X-Drive 701FW
Fairway Woo

Tourstage



introduces it's all new X-Drive 701FW for the better player. A mid-compact head with a square face, the 701FW is mad...

MSRP:
\$325.50 **\$279.00**

[▶ More info](#)

Tourstage 2009 X-UT 101w Wood
Utility

Tourstage



introduces two new utilities in their X lineup for 2009. The second utility is the X-UT 101w, a utility geared at the be...

MSRP:
\$295.00 **\$255.00**

[▶ More info](#)

Tourstage 2009 X-UT 101i Iron
Utility

Tourstage



introduces two new utilities in their X lineup for 2009. The first is the X-UT 101i, a driving iron utility for those lo...

MSRP:
\$262.50 **\$235.00**

[▶ More info](#)

Diamana 2009 kai'li Shaft



Mitsubishi
Rayon

introduces an all new shaft for the 2009 season, the new kai'li. The kai'li is a multi dimensional design...

MSRP:
\$420.00 **\$299.00**

[▶ More info](#)

ONOFF 2008 Pro Shoe OS0108



ONOFF
golf

introduces their new Pro Golf Shoe. The new OS0108 model is designed to be light but stable providing maximum grip and ...

MSRP:
\$169.00

[▶ More info](#)

Dance With Dragon Pyramid Studs Belt D3-



Dance
with

Dragons all new Pyramid Studs Belt is a stylish all cow leather belt covered in black and silver studs spelling out D.W...

MSRP:
\$169.00

[▶ More info](#)

Mizuno 2009 Custom MP Craft R1 Driver



Mizuno

introduces it's all new and redesigned MP Craft Driver for 2009. The new MP craft is a 460cc all Titanium driver availa...

MSRP:
\$892.50 **\$799.00**

[▶ More info](#)

Mizuno 2009 Custom MP Craft T1 Driver

Mizuno



introduces it's all new and redesigned MP Craft Driver for 2009. The new MP craft is 460cc all Titanium driver availabl...

MSRP:

~~\$892.50~~ **\$799.00**

[▶ More info](#)

Epon 2008 Ball Marker

Epon's stylish ball marker includes two ball



markers, a black/gold marker and a white/gold marker, and a hat cl...

MSRP:

\$26.50

[▶ More info](#)

Epon 2009 Pro Cap



Epon's new stylish 2009 Pro cap is free size and

available in 3 awesome colors. A must for any Epon Japan Forged Fan! ...

MSRP:

\$35.00

[▶ More info](#)

Tourstage 2008 Caddy Bag CBTV87



Tourstage's new 2008 CBTV87 Caddy bag is made of durable

poly urethane and weighs 4.5kg. It features a 9" opening and V Tread ...

MSRP:

\$304.50

[▶ More info](#)

Tourstage 2008 Caddy Bag CBTV88



The
new
CBTV
Caddy
Bag
from

Tourstage is a stylish 4.6kg bag with 9" opening and Bridgestone's Tread grip bottom. It is made o...

MSRP:

\$346.50

[▶ More info](#)

Tourstage 2008 ViQ Deep Driver Tourstage



introduces their all new ViQ Deep driver based on the top selling and performing 2008 ViQ driver. The new ViQ Deep featu...

MSRP:

\$787.50 ~~\$675.00~~

[▶ More info](#)

Tourstage 2008 Pro Model Tread Shoe SHV8



Tourstages
all new
2008
SHV850
Pro
shoe is

worn several players on the Japanese tour. Weighing a stable 410g and featuring To...

MSRP:

\$199.50

[▶ More info](#)

Miura 2008 CB-2006 Irons 3-PW Miura Giken Japan



introduces their all new cavity back for 2008 the CB-2006. Miura based this new cavity on a clean and flow...

MSRP:

\$1,120.00 ~~\$999.00~~

[▶ More info](#)

Bettinardi Pro Caddy Bag BCB0701



Bettinardi's new Pro Caddy bag is a full sized caddy bag

featuring a three point harness and a 9" opening. It is made of high ...

MSRP:

\$378.00

[▶ More info](#)

Gold's Factory Anser No.2 Fe



Gold's Factory clubs are the pinnacle of quality and high

end clubs in Japan. Gold's Factory founder, master grinder a...

MSRP:

\$525.00

[▶ More info](#)

Fujikura Rombax F Series Shaft



Fujikura Shaft

releases the all new Rombax F with a pearl white design. The concept of the F shaft is that it is a shaft that fits...

MSRP:

\$388.50 ~~\$289.00~~

[▶ More info](#)

Yamaha 2008 Inpres X PT-201 Putter



Yamaha

introduces its all new Inpres X PT-201 putter. The PT-201 features a super soft Magnesium Aluminum mix insert for ama...

MSRP:

\$220.00 ~~\$199.00~~

[▶ More info](#)

Yamaha 2008 Inpres X PT-101
Putter



Yamaha

introduces its all new Inpres X PT-101 putter. The PT-101 features a super soft Magnesium Aluminum mix insert for ama...

MSRP:
\$220.00 **\$199.00**

[▶ More info](#)

Royal Collection 2008 RC Star P2
Putter



The new 2008 RC Star P2 Putter from Royal

Collection is a unique Neo-Mallet style putter featuring super soft SUS304 construction....

MSRP:
\$275.00 **\$260.00**

[▶ More info](#)

[MORE NEW PRODUCTS](#)

[Tour Spec Golf Pro Shop](#) | [Contact Us](#) | [My Account](#) | [Track Order](#) | [About TourSpecGolf](#) | [Privacy Policy](#) | [Site Map](#)
[Japanese Golf Clubs](#) | [Golf Accessories](#) | [Golf Balls](#) | [Golf Apparel](#) | [Golf Clubs and Equipment](#) | [Golf Bags](#) | [Golf Club Manufacturers](#)
[Golf Drivers](#) | [Fairway woods](#) | [Driving Irons](#) | [Golf Iron Sets](#) | [Golf Wedges](#) | [Golf Putter](#)s | [Golf Club Shafts](#) | [Golf Club Grips](#)
[Golf Gifts](#) | [Custom Golf Club Fitting](#) | [Golf Head Covers](#)

Copyright ©2008 TourSpecGolf - All Rights Reserved - [Terms of Use](#)

All website designs, text, graphics, art work, photographs, and selection and arrangement there of are the copywritten works of TourSpecGolf.

To sign up for exclusive email only specials and offers, [Click Here](#)

823376

Enviro.aero

- [What's the problem?](#)
- [Finding solutions](#)
- [Plane Talking](#)
- [Media Centre](#)
- [The Hold](#)
- [The Flight Path](#)
- [About us](#)

[This website requires the Flash plug-in to be installed. Click here to get Flash](#)

