

# E-AC



## Low Cost, Small Package, 120VAC Microstepping Drive

Compumotor's new E-AC is a low-cost, high-performance, high-reliability microstepping drive in a small package. The design of the E-AC is based on the design of our proven Zeta and OEM750 microstepping drives. It provides up to 3.5 Amps of current to the motor and accepts 120VAC direct-online power only. All step motors are subject to mid-range instability or oscillations. The E-AC incorporates an anti-resonance circuitry that aggressively and effectively suppresses these oscillations, thus taking advantage of the full capabilities of the step motor.

### Features

#### Performance

- Designed for use with motor inductance of 0.5 mH - 80 mH
- 3-state current control allows the drive and motor to run cooler and more efficiently than 2-state drives
- Selectable resolution up to 50,800 steps/rev
- Auto standby reduces motor current (and heating) at rest
- Provides 0.02 Amps to 3.5 Amps (peak)
- 95 - 132VAC power supply input
- Four predefined current waveforms to optimize smoothness

#### Protection

- Optically isolated step and direction inputs
- Short circuit protection – phase-to-phase and phase-to-ground
- Auto-run feature to verify proper system operation
- Over temperature circuitry protects the drive from thermal damage

#### Physical

- Status/fault LED indicators to confirm proper operation
- ASIC and surface-mount technologies minimize product footprint, overall package size and increase product reliability
- Optically isolated fault output for embedded applications
- Simplified, 2-screw mounting
- Overall dimensions: 2.25 x 4.3 x 1.9 in. (133 x 109 x 48 mm)
- Certified as UL-recognized component
- Approvals: CE (LVD), and CE (EMC)

**E-AC Specifications**

	Parameter	Value
<b>Power Input</b>	AC	95 - 132 VAC @ single phase 50/60 Hz
<b>Performance</b>	Accuracy	±5 arc min (0.0833°) typical. Unloaded-bidirectional with Compumotor supplied motors. Other motors may exhibit different absolute accuracy. ±1 arc min (0.0167°) typical/per each frictional load equal to 1% rated torque. Loaded-in addition to unloaded accuracy.
	Repeatability	±5 arc sec (0.0014°) typical. Unloaded-one revolution returning to start point from same direction.
	Hysteresis	Less than 2 arc min (0.0334°) unloaded-bidirectional.
	Resolution	16 selectable choices: 200, 400, 1000, 2000, 5000, 10000, 12800, 18000, 20000, 21600, 25000, 25400, 25600, 36000, 50000, 50800
	Waveform	Selectable. Allows waveform shaping for optimum smoothness or relative accuracy. Pure sine; -4%, -6%, -8%, 3rd harmonic.
<b>Amplifier</b>	Type	20 kHz fixed frequency, variable duty cycle pulse width modulated (PWM ) Current Controlled, bipolar chopper
	Number of Phases	2
	Output Current	0.02–3.5 Amps peaks of Sine
	Standby Current Reduction	50% of selected motor current
	Nominal Chopping Frequency	20 kHz
	Max Stepping Rate	2 MHz max pulse rate; 50 rps max speed
	Step Input	High-going pulse, 200 nsec min width; max pulse rate is 2 MHz; User-supplied driver for the step and direction inputs should be capable of providing a minimum of 6.5 mA to maximum of 15 mA
	Direction Input	Logic High = positive (CW) rotation—3.5–5.0V Logic Low = negative (CCW) rotation—0–0.4V User-supplied driver for the step and direction inputs should be capable of providing a minimum of 6.5 mA to a maximum of 15 mA. The direction input must be stable for at least 200 µsec before the drive receives the first pulse
	Fault Output	Open-Collector/Emitter, Vce = 70 VDC, Vce sat = 0.3 VDC, Ic = 40 mA (max) Maximum dissipation = 40 mW Conducting = normal operation Non conduction = drive fault
<b>Protective Circuits</b>	Short Circuit*	Phase-to-phase, phase-to-ground If AC supply drops below 85VAC
	Overtemperature*	The drive will fault if heat plate exceeds 55°C
<b>Environmental</b>	Drive Temp	Max allowable ambient temperature is 122°F (50°C). Fan cooling may be required if airflow is restricted.
	Humidity	0 to 95%, Non-condensing
<b>Physical</b>	Drive Dimensions	5.35 x 4.34 x 1.89in (135 x 110 x 48 mm)
	Weight	1.2 lbs
<b>Motor</b>	Type	Two-phase hybrid permanent magnet, 1.8°
	Number of Leads	4, 6, or 8
	Inductance Range	0.5 minimum; 5 to 50 mH recommended range; 100 mH max

\* Drive shuts down in conditions listed. Power must be cycled or drive reset to resume operations.

See Servo Drive section for the full line of Gemini servo drives and drive/controllers.



## Lower-Cost DC Power Input Microstepping Drive

Compumotor's new E-DC microstepping drive is designed for a 48VDC input power requirement and provides current up to 4.8 Amps peak of current to the motor.

### Features

#### Performance

- Designed for use with motor inductance range of 0.2 mH–80 mH
- Three-state current control allows the drive and motor to run cooler and more efficiently than two-state drives
- Selectable resolution up to 50,800 steps/rev
- Auto standby reduces motor current (and heating) at rest
- Provides 0.2 Amps to 4.8 Amps (peak)
- Single 24-48 VDC power supply input
- Compatible with a variety of motors
- Six predefined current waveforms to optimize smoothness

#### Protection

- Optically isolated step and direction inputs
- Short circuit protected—phase-to-phase, and phase-to-ground
- Power dump circuitry to protect drive from regeneration caused by large inertial loads
- Self-test feature to verify proper system operation
- Overtemperature circuitry protects the drive from thermal damage

#### Physical

- Status/fault LED indicators to confirm proper operation
- ASIC and surface mount technologies minimize product footprint, overall package size, and increase product reliability
- Removable snap-on molded cover for convenient configuration and protection against contaminants
- Optically isolated fault output for embedded applications
- Heat plate design allows thermal dissipation through a suitable heat dissipating mounting surface
- Simplified, two-screw mounting
- Right-angle screw terminal allows side-to-side mounting or Eurorack compatibility
- Overall dimensions 5.0 x 3.6 x 1.6 in. (127 x 91 x 41 mm)
- Convenient configuration DIP switches
- Certified as UL-recognized component
- CE (LVD & EMC)

**E-DC Drive Specifications**

	Parameter	Value
<b>Power Input</b>	DC	24–48 VDC @ 2.0 Arms (motor dependent)
	<b>Performance</b>	
	Accuracy	±5 arc min (0.0833°) typical. Unloaded-bidirectional with Compumotor supplied motors. Other motors may exhibit different absolute accuracy. ±1 arc min (0.0167°) typical/per each frictional load equal to 1% rated torque. Loaded-in addition to unloaded accuracy.
	Repeatability	±5 arc sec (0.0014°) typical. Unloaded-one revolution returning to start point from same direction.
	Hysteresis	Less than 2 arc min (0.0334°) unloaded-bidirectional.
	Resolution	16 selectable choices: 200, 400, 1000, 2000, 5000, 10000, 12800, 18000, 20000, 21600, 25000, 25400, 25600, 36000, 50000, 50800
	Waveform	Selectable. Allows waveform shaping for optimum smoothness or relative accuracy. Pure sine; -4%, -6%, -8%, -10% 3rd harmonic.
<b>Amplifier</b>	Type	20 kHz fixed frequency, variable duty cycle pulse width modulated (PWM ) Current Controlled, bipolar chopper
	Number of Phases	2
	Output Current	0.2–4.8 amps current per phase peak (selectable)
	Drive Supply Voltage	24–48 VDC (dependent on external power supply)
	Standby Current Reduction	25%, 50%, or 75% of selected motor current
	Nominal Chopping Frequency	20 kHz
	Max Stepping Rate	2 MHz max pulse rate; 50 rps max speed
	Step Input	High-going pulse, 200 nsec min width; max pulse rate is 2 MHz; User-supplied driver for the step and direction inputs should be capable of providing a minimum of 6.5 mA to maximum of 15 mA
	Direction Input	Logic High = positive (CW) rotation—3.5–5.0V Logic Low = negative (CCW) rotation—0–0.4V User-supplied driver for the step and direction inputs should be capable of providing a minimum of 6.5 mA to a maximum of 15 mA. The direction input must be stable for at least 200 µsec before the drive receives the first pulse
	Fault Output	Open-Collector/Emitter, Vce = 70 VDC, Vce sat = 0.3 VDC, Ic = 10 mA (max) Maximum dissipation = 55 mW Conducting = normal operation Non conduction = drive fault
<b>Protective Circuits</b>	Short Circuit*	Phase-to-phase, phase-to-ground
	Undervoltage	If DC supply drops below 24 VDC
	Overtemperature*	The drive will fault if heat plate exceeds 55°C
<b>Environmental</b>	Drive Temp	Max allowable ambient temperature is 122°F (50°C). Fan cooling may be required if airflow is restricted. Max allowable heatplate temperature is 55°C.
	Humidity	0 to 95%, Non-condensing
<b>Physical</b>	Drive Dimensions	5.0 x 3.6 x 1.6 in (127 x 91 x 41 mm)
	Weight	12 oz
<b>Motor</b>	Type	Two-phase hybrid permanent magnet, 1.8°
	Number of Leads	4, 6, or 8
	Inductance Range	0.2 mH–80 mH

\* Drive shuts down in conditions listed. Power must be cycled or drive reset to resume operations.

See Servo Drive section for the full line of Gemini servo drives and drive/controllers.

E Series Connections

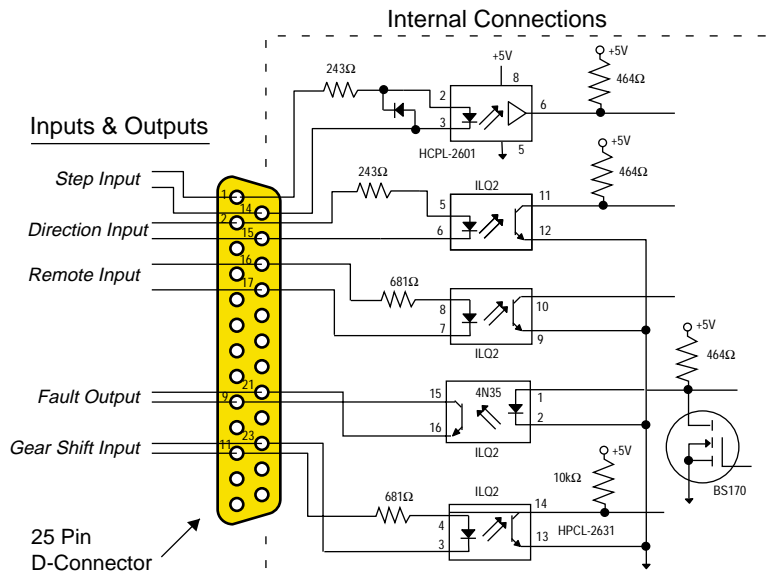

E Series Screw-Terminal	
Pin No	Signal
1 (Top)	LINE
2	NEUTRAL
3	GND
4	MOTOR GND
5	A+
6	A-
7	B+
8 (Bottom)	B-

E-AC Dimensions

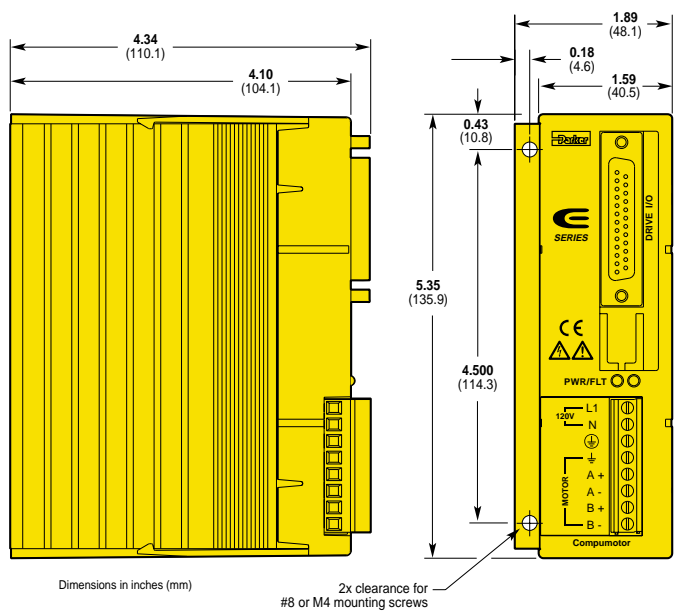

E-DC Drive Dimensions

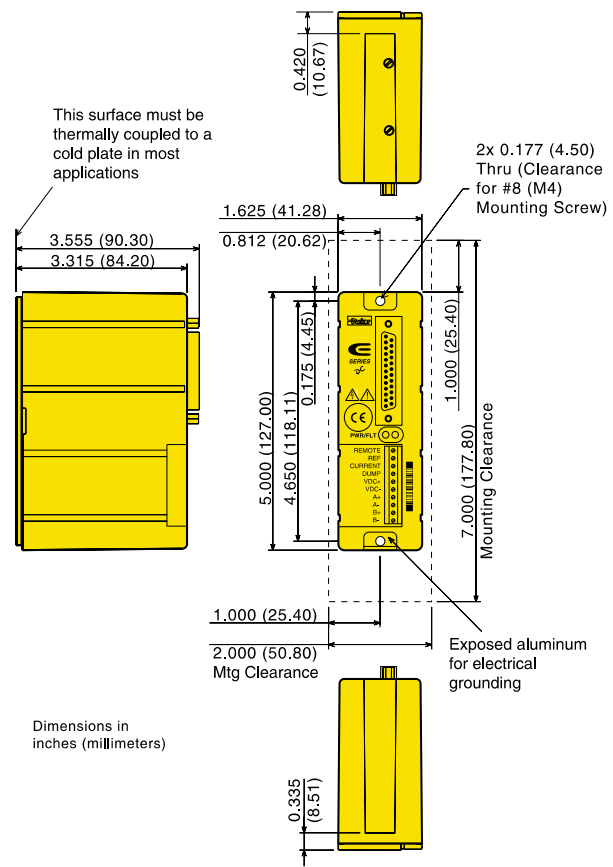

**OS Series  
 Motor Specifications  
 Size 23 Frame**

Parameters		E-DC			E-AC		
		OS2HA	OS21A	OS22A	OS2HB	OS21B	OS22B
Static torque	oz-in	49.1	114	186	61.35	126.5	238
	(Nm)	(0.35)	(0.81)	(1.31)	(0.43)	(0.84)	(1.68)
Rotor inertia	oz-in <sup>2</sup>	0.39	0.66	1.39	0.39	0.66	1.39
	(kg-cm <sup>2</sup> )	(0.07)	(0.12)	(0.25)	(0.07)	(0.12)	(0.25)
Drive Current Apk (Arms)	Series	3.0 (2.12)	4.8 (3.39)	4.8 (3.39)	1.76 (1.24)	1.88 (1.33)	2.38 (1.68)
	Parallel	NA	NA	NA	3.25 (2.30)	3.5 (2.47)	3.5 (2.47)
Phase Inductance (mH)	Series	1.7	1.8	2.8	8.6	12	16.6
	Parallel	NA	NA	NA	2.2	3	4.2
Detent Torque	oz-in	2.5	4.0	7.0	2.5	4.0	7.0
	(N-m)	(0.02)	(0.03)	(0.05)	(0.02)	(0.03)	(0.05)
<b>Bearings Information</b>							
Thrust Load	lb	13	13	13	13	13	13
	(kg)	(5.9)	(5.9)	(5.9)	(5.9)	(5.9)	(5.9)
Radial Load	lb	20	20	20	20	20	20
	(kg)	(9.1)	(9.1)	(9.1)	(9.1)	(9.1)	(9.1)
End Play (Reversing load equal to 1 lb)	in	0.001	0.001	0.001	0.001	0.001	0.001
	(mm)	(0.025)	(0.025)	(0.025)	(0.025)	(0.025)	(0.025)
Radial Play (Per 0.5 lb load)	in	0.0008	0.0008	0.0008	0.0008	0.0008	0.0008
	(mm)	(0.02)	(0.02)	(0.02)	(0.02)	(0.02)	(0.02)
Motor Weight	lb	1	1.5	2.5	1	1.5	2.5
	(kg)	(0.5)	(0.7)	(1.1)	(0.5)	(0.7)	(1.1)
Certifications	UL recognized	Pending	Pending	Pending	Pending	Pending	Pending
	CE (LVD)	Yes	Yes	Yes	Yes	Yes	Yes
	CE (EMC & LVD)	No	No	No	No	No	No

See Servo Drive section for the full line of Gemini servo drives and drive/controllers.

**VS Series  
 Motor Specifications  
 Size 17, 23 and 34 Frame**

Parameters		Size 17 Frame		Size 23 Frame			Size 34 Frame	
		VS12B	VS13B	VS21B	VS22B	VS23B	VS31B	VS32B
Static torque - E-AC	oz-in	55.27	72.8	115.5	194.5	334.5	551.8	1269.67
	(Nm)	(0.39)	(0.51)	(0.82)	(1.37)	(2.36)	(3.90)	(8.97)
Static torque - E-DC	oz-in	58	81	115	156	330	442	664
	(Nm)	(0.41)	(0.57)	(0.81)	(1.10)	(2.33)	(3.12)	(4.69)
Rotor inertia	oz-in <sup>2</sup>	0.3	0.37	0.66	1.64	2.62	7.65	14.8
	(kg-cm <sup>2</sup> )	(0.054)	(0.068)	(0.12)	(0.3)	(0.48)	(1.4)	(2.7)
Drive Current Apk (Arms) - E-AC	Series	1.0 (0.71)	1.01(0.71)	2.26 (1.6)	2.01 (1.42)	2.01 (1.42)	3.0 (2.12)	3.13 (2.21)
	Parallel	2.0 (1.42)	2.02 (1.43)	3.5 (2.47)	3.5 (2.47)	3.5 (2.47)	3.5 (2.47)	3.5 (2.47)
Drive Current Apk (Arms) - E-DC	Series	NA	NA	NA	NA	NA	NA	NA
	Parallel	3.0 (2.12)	3.0 (2.12)	4.8 (3.39)	4.0 (2.83)	4.8 (3.39)	4.8 (3.39)	4.8 (3.39)
Phase Inductance (mH)	Series	12.8	11.2	5	12	15.4	15.8	25.0
	Parallel	(3.2)	(2.8)	(1.25)	(3.0)	(3.85)	(3.95)	(6.25)
Detent Torque	oz-in	2.5	4.0	7.0	8.8	18.0	27.0	50
	(N-m)	(0.02)	(0.03)	(0.05)	(0.06)	(0.13)	(0.19)	(0.35)
<b>Bearings Information</b>								
Thrust Load	lb	11.0	11.0	17.6	17.6	17.6	35.3	35.3
	(kg)	(5)	(5)	(8)	(8)	(8)	(16)	(16)
Radial Load	lb	7.7	7.7	15.0	15.0	15.0	30.9	30.9
	(kg)	(3.5)	(3.5)	(6.8)	(6.8)	(6.8)	(14)	(14)
End Play (with 2.2 lbs axial load)	in	0.003	0.003	0.003	0.003	0.003	0.0032	0.0032
	(mm)	(0.075)	(0.075)	(0.075)	(0.075)	(0.075)	(0.080)	(0.080)
Radial Play (with 1.1 lb radial load)	in	0.001	0.001	0.001	0.001	0.001	0.0008	0.0008
	(mm)	(0.025)	(0.025)	(0.025)	(0.025)	(0.025)	(0.020)	(0.020)
Motor Weight	lb	0.55	0.77	1.03	1.54	2.2	3.86	6.18
	(kg)	(0.25)	(0.35)	(0.47)	(0.7)	(1.0)	(1.75)	(2.8)
Certifications	UL recognized	No	No	No	No	No	No	No



**Motor Speed-Torque Performance Curves**  
**E-AC with OS and VS Series motors, 17, 23 and 34 frame**

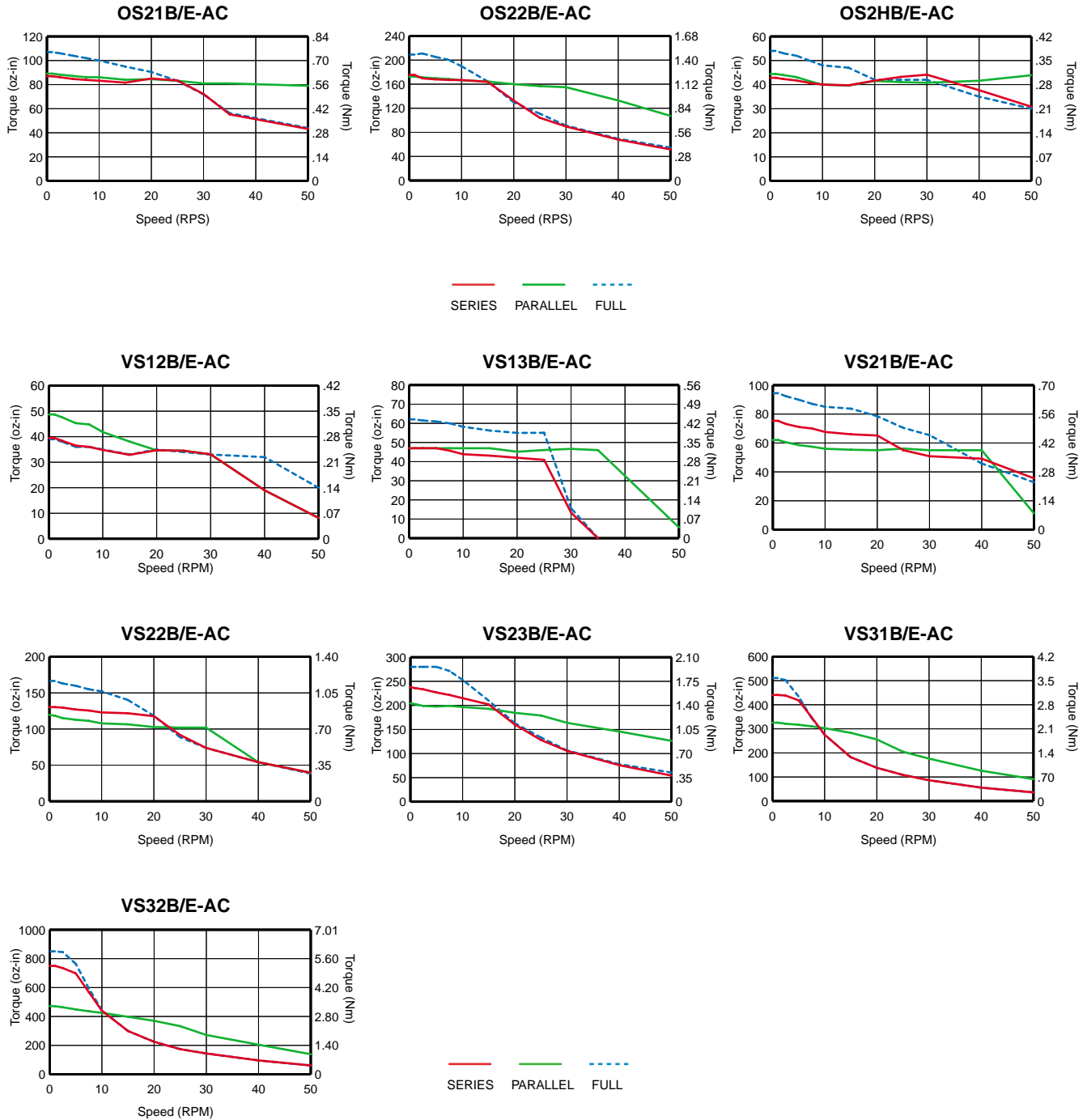

See Servo Drive section for the full line of Gemini servo drives and drive/controllers.

# Motor Speed-Torque Performance Curves

E-DC Drive with OS and VS Series motors, 17, 23 and 34 frame

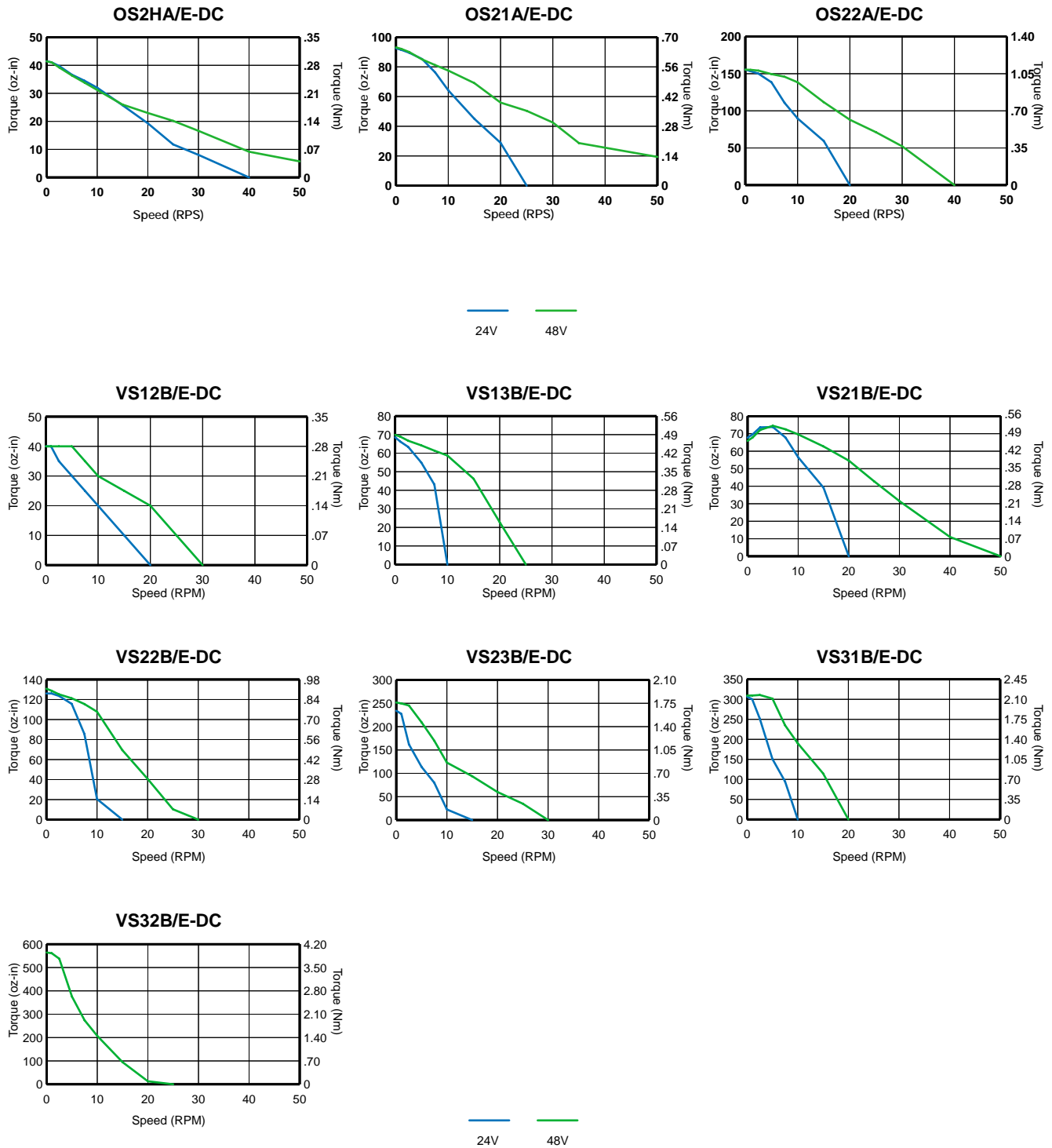

# Dimensional Drawings

## VS Series Motors, Size 17 Frame

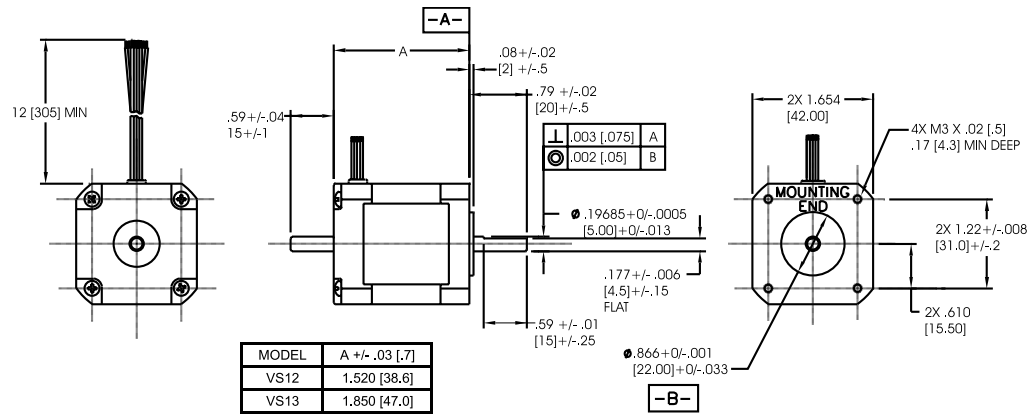

## Size 23 Frame

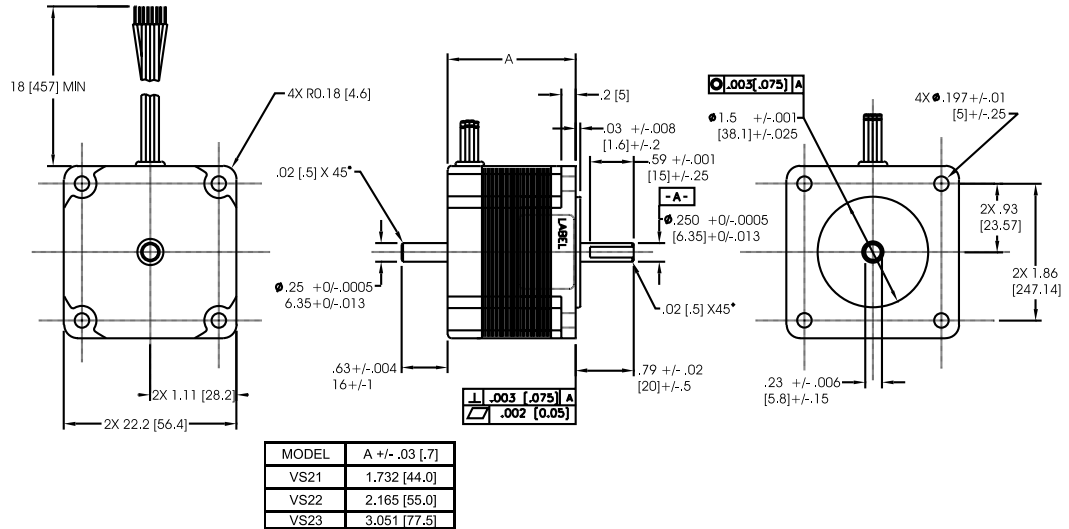

## Size 34 Frame

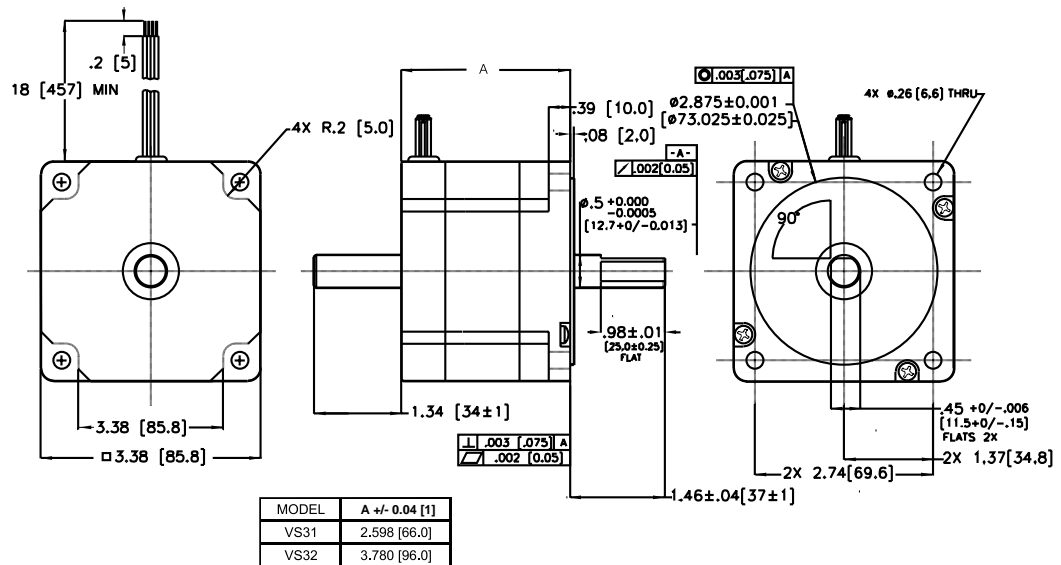

See Servo Drive section for the full line of Gemini servo drives and drive/controllers.