

ZETA Series CE Motor Dimensional Drawings

Size 23 Frame, O Series

Dimensions in inches (mm)

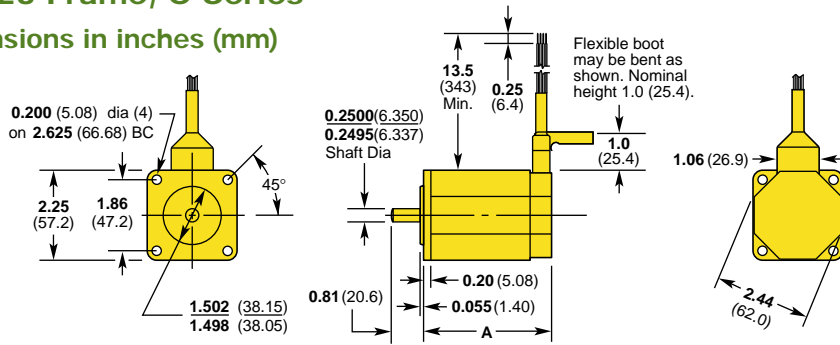

Model	A	
OS2HA (OEM57-40)	1.60 (40.6)	
OS21HA (OEM57-51)	2.06 (52.3)	
OS22HA (OEM57-83)	3.10 (87.7)	

Size 34 Frame, R Series

Dimensions in inches (mm)

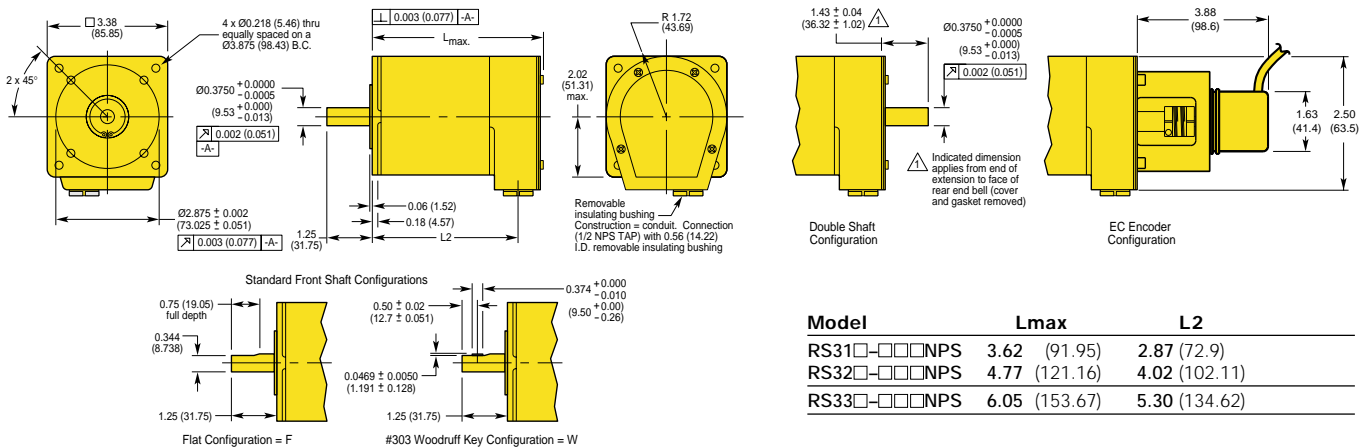

Model	Lmax	L2
RS31□-□□□NPS	3.62 (91.95)	2.87 (72.9)
RS32□-□□□NPS	4.77 (121.16)	4.02 (102.11)
RS33□-□□□NPS	6.05 (153.67)	5.30 (134.62)

Size 42 Frame, R Series

Dimensions in inches (mm)

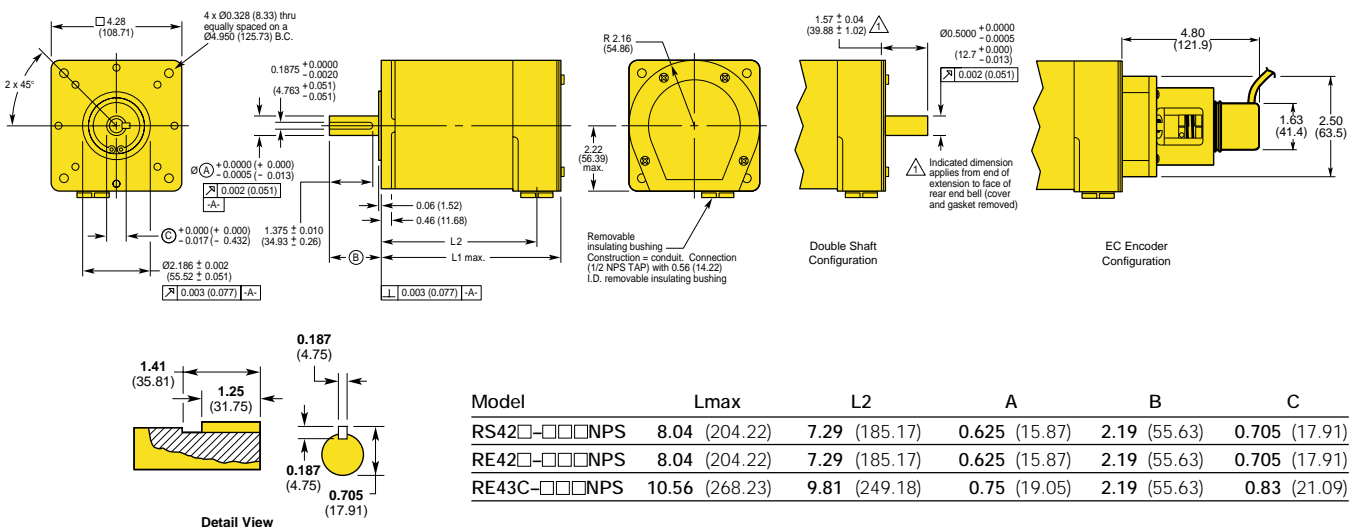

Model	Lmax	L2	A	B	C
RS42□-□□□NPS	8.04 (204.22)	7.29 (185.17)	0.625 (15.87)	2.19 (55.63)	0.705 (17.91)
RE42□-□□□NPS	8.04 (204.22)	7.29 (185.17)	0.625 (15.87)	2.19 (55.63)	0.705 (17.91)
RE43C-□□□NPS	10.56 (268.23)	9.81 (249.18)	0.75 (19.05)	2.19 (55.63)	0.83 (21.09)

ZETA Series: True Innovation in Microstepping Technology. Call 1-800-358-9070 Today.

ZETA Series CE Motor Dimensional Drawings

Size 34 Frame, T Series

Dimensions in inches (mm)

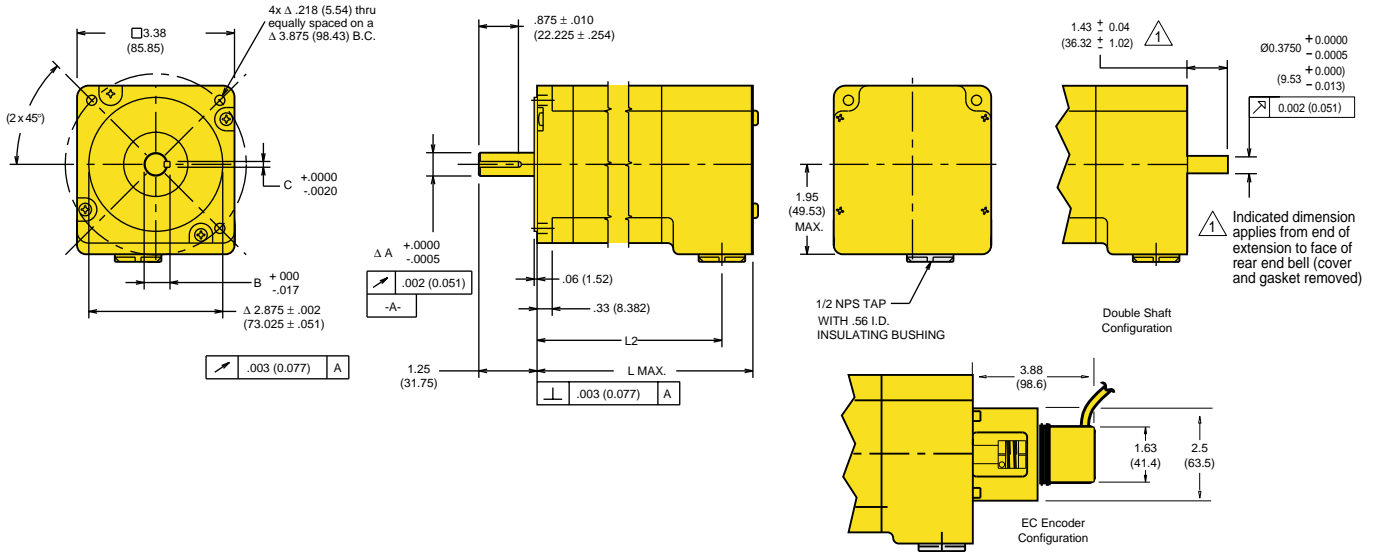

Size 42 Frame, T Series

Dimensions in inches (mm)

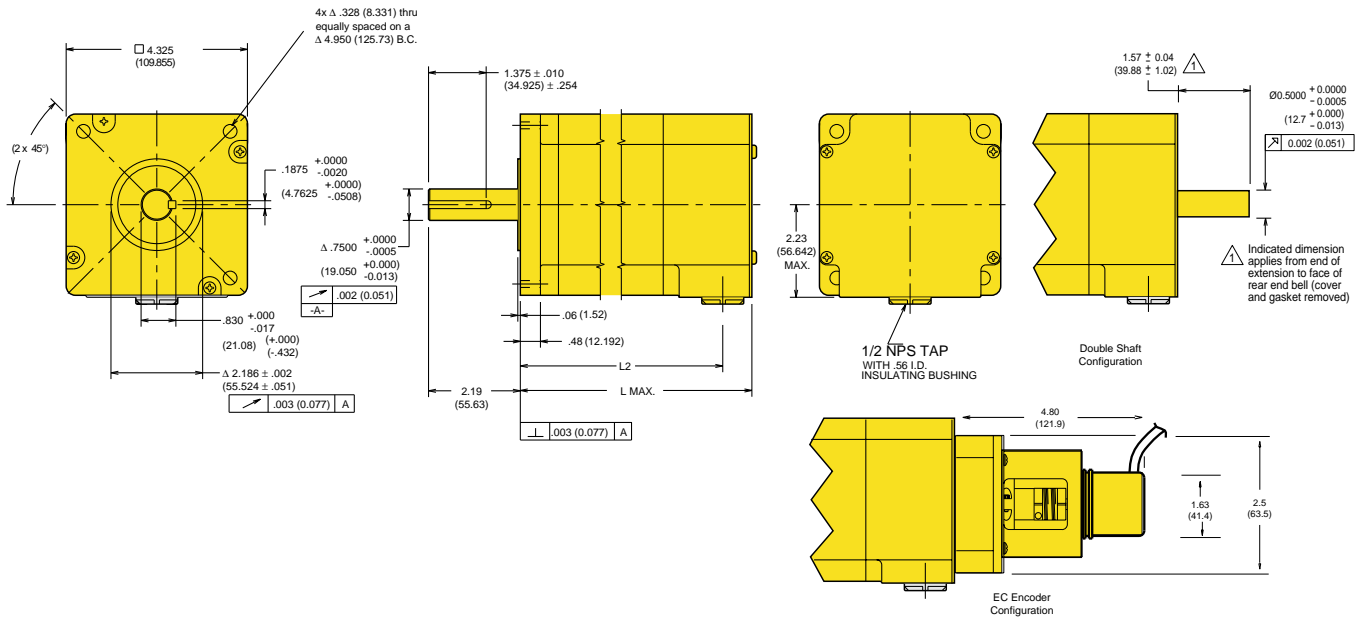

For ZETA Series Motor Specifications and dimensions, please refer to the E Series Motor Specifications located in the Gemini Section.

Model	Lmax	L2
TS41B-□K□NPS	5.20 (132.08)	4.46 (113.28)
TS42B-□K□NPS	7.22 (183.39)	6.48 (164.59)
TS43B-□K□NPS	9.23 (234.44)	8.49 (215.65)

Drives & Drive/Controllers

controllers
 drives
 motors