

View A

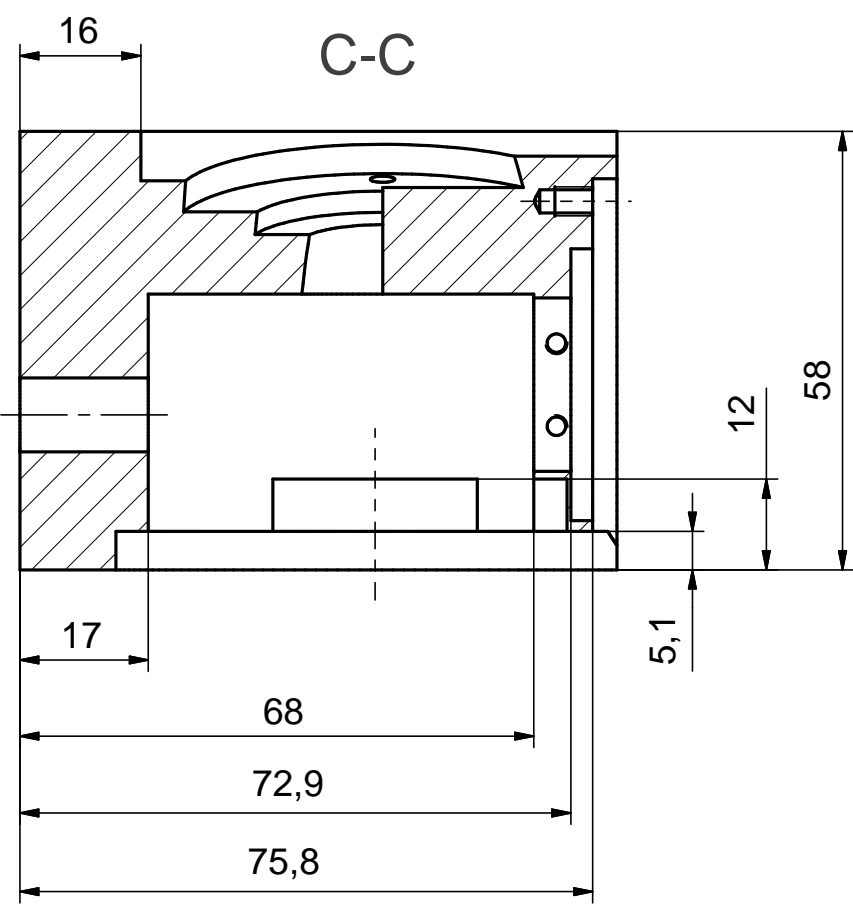
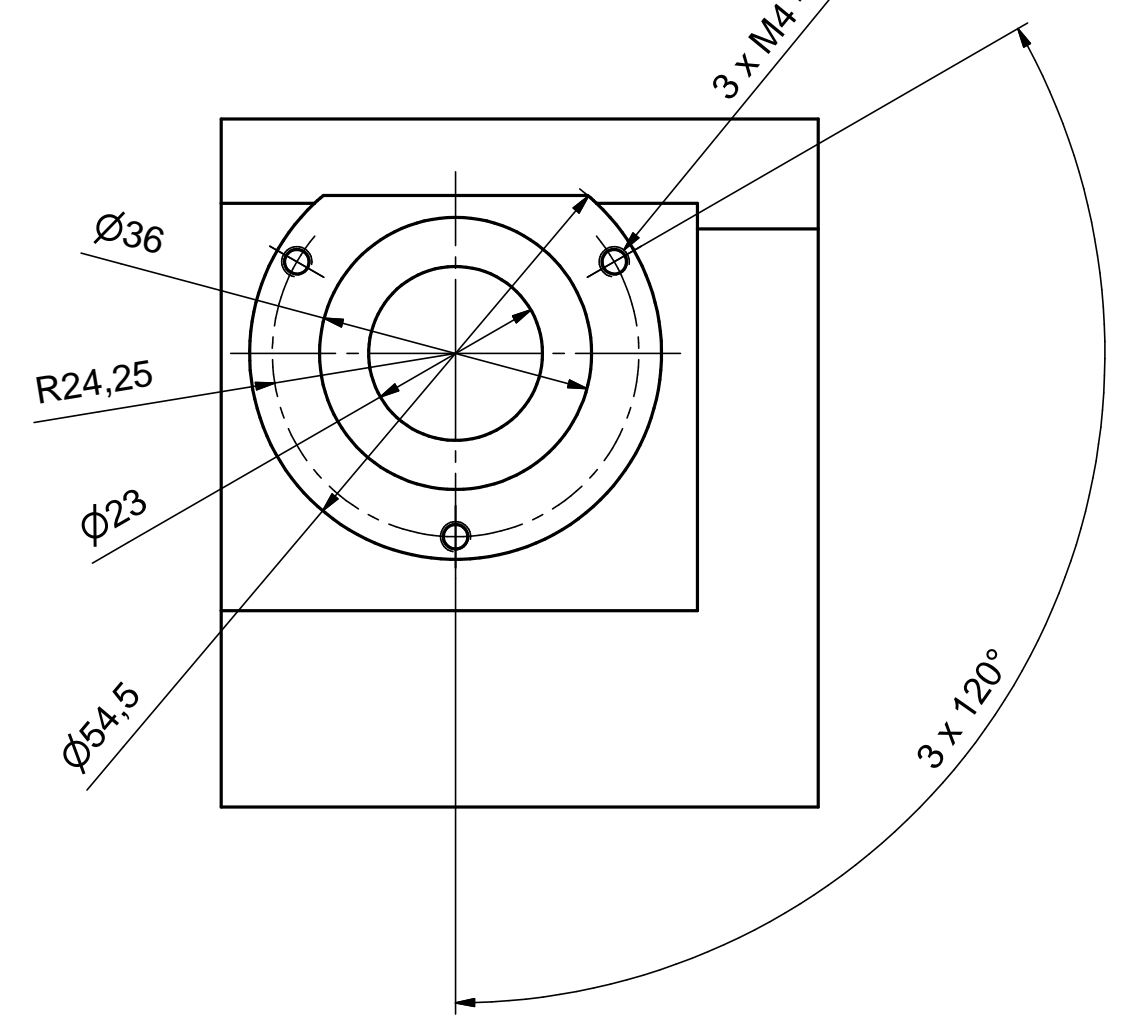

Volume: 2,025E+005 mm<sup>3</sup>

First angle projection. All dimensions in mm.		Shrinkage (est.):			
Material: 3.2315 AlMgSi1		Length:	Across:		
Surface treatment:		Not indicated			
		Draft:	Fillets:		
<b>Inventor NG World Cup</b> <b>Original model by Torsten Stein</b>					
Heat treatment:		Scale:	Tolerances acc. to standard:	Rev. No.:	Signature / date:
		1:1			
www.ambu.com		Drawn:	TS	04-02-14	August04
		Appr.:			