

LED Drivers for High-Brightness Lighting

Solutions Guide

national.com/LED

2009 Vol. 1

General Illumination LED Drivers

Technology Overview

Product Highlights

Application Information

Design Examples

Articles

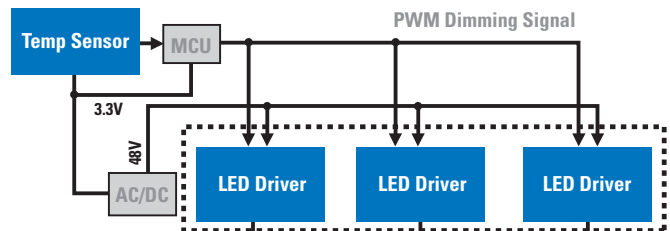

High-Brightness LED Lighting

Overview

Regardless of type, color, size, or power, all LEDs work best when driven with a constant current. LED manufacturers specify the characteristics (such as lumens, beam pattern, color) of their devices at a specified forward current (I_f) not at a specific forward voltage (V_f).

Most power supply ICs are designed to provide constant voltage outputs over a range of currents (see below), hence it can be difficult to ascertain which parts will work for a given application from the device datasheet alone.

With an array of LEDs, the main challenge is to ensure every LED in the array is driven with the same current. Placing all the LEDs in a series string ensures that exactly the same current flows through each device.

High-Brightness LEDs: Input Voltage and Forward Voltage

Sources of input voltage for LED arrays come from batteries or power supplies that have a certain tolerance. An automotive battery, for example, may supply 8V to 16V depending on the load and the age of the battery. The 'silver box' power supply inside a desktop CPU may supply $12V \pm 10\%$.

High-brightness (HB) LEDs also give a range of forward voltage. A typical HB LED might be characterized at a forward current of 350 mA. The forward voltage of the LED when $I_f = 350$ mA is specified with a range that includes a typical value as well as over-temperature maximum and minimum values. To ensure that a true constant current is delivered to each LED in an array, the power topology must be able to deliver an output voltage equal to the sum of the maximum forward voltages of every device placed in the string.

Manufacturers bin their devices for color, brightness, and forward voltage. Binning for all three characteristics is expensive, and forward voltage is often the specification that is allowed to vary the most. Adding this to the shift in forward voltage as the LED die temperature changes gives rise to the need for constant current regulators that have a wide range of output voltage.

Constant Voltage Regulator

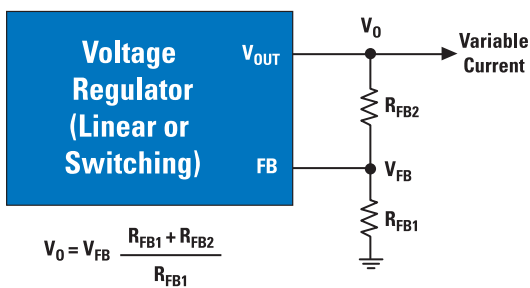

Constant Current Regulator

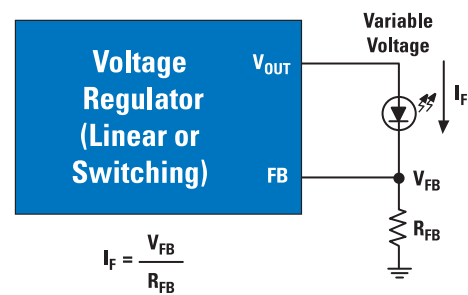

When Input Voltage Exceeds LED Voltage

If input voltage always exceeds the sum of the maximum forward voltages of every LED in a string, then two options are available: linear regulators and buck regulators.

A linear regulator introduces efficiency and thermal drawbacks, but is the simplest design option. In order to provide constant current, the linear regulator must be an adjustable type that uses a pair of feedback resistors. Replacing the top feedback resistor with the LED string and placing a current-sensing resistor in the bottom position 'tricks' the former constant voltage source into adjusting the output voltage until enough current flows through the current sensing resistor to equal the feedback voltage of the IC.

Linear regulators have the advantages of simplicity and low parts count, and generate very little EMI. They can deliver constant current as long as the V_F in the LED string does not exceed their dropout limited output voltage. The disadvantage lies in efficiency and thermal dissipation. Loss in a linear regulator LED driver is approximately equal to $(V_{IN} - n \times V_F) \times I_F$, where 'n' is the number of LEDs in the string. At currents of 350 mA and above, the linear solution may require a heatsink, adding cost and size to the design.

The more efficient option when input voltage always exceeds the LED voltage is a step-down or buck regulator. As with linear regulators, this must be an adjustable type, and the same method can be used to turn almost any buck regulator into a constant current source for LEDs. Buck regulators enjoy high efficiency and eliminate the need for a heatsink, at the cost of a more complex circuit and the addition of switching noise. Many recent buck regulators switch at 1 MHz and above, making their external components so small that at currents under 1A they may actually use less space than a linear regulator.

When Input Voltage is Less than LED Voltage

When the minimum forward voltage of all the LEDs in a string will always exceed the maximum input voltage, a step-up, or boost regulator is needed.

The inductive-boost converter is the simplest regulator that can deliver currents above 350 mA with a varying output voltage. As with linear and buck regulators, a boost converter with a feedback-divider network can be modified to become a constant current source. One important distinction between the buck regulator and boost regulator must be made when the power switch is internal to the control IC. Such monolithic systems have a fixed current limit.

In buck regulators, the internal switch passes the same DC current as the LED. A boost converter differs in that the internal switch sees a higher current that varies with input voltage; the greater the difference between V_{IN} and V_{OUT} , the higher the internal switch current. Care must be taken to evaluate a monolithic boost regulator-based LED drive to make sure that it will not hit the fixed current limit over the range of input voltage.

When Input Voltage Range Overlaps LED Voltage Range

As HB LEDs are adopted into more and more applications, situations will arise when the input voltage varies above and below the forward voltage of the LED string. For these cases, a current regulator is needed that can both buck and boost as required by the input and output conditions. Possible topologies include the buck-boost, SEPIC, Cuk, flyback, and V_{IN} referenced buck-boost (also called the floating buck-boost).

In all of these topologies, the power-switch current exceeds the LED current and varies with input voltage. The same attention to peak switch current must be made over the full range of input voltage, especially if a regulator with an internal power switch and fixed current limit is implemented. For more information about National's LED products, samples, design simulation tools, and more, visit:

www.national.com/LED.

LED Drivers Selection Tables

Buck (Step-down) High-Brightness LED Drivers

Product ID	V _{in} Range (V)	V _{out} (V)	I _o (A)	No. of LED	Multi-output	Internal SWITCH	Topology	Key Features
LM3401	4.5 to 35	Up to 35	3	1 to 9	No	No	Buck	Dual-side hysteresis, very low reference voltage and short propagation delay
LM3402/HV	6 to 42/6 to 75	Up to 37/67	0.425	1 to 9/15	No	Yes	Buck	200 mV feedback voltage, fast PWM dimming
LM3404/HV	6 to 42/6 to 75	Up to 37/67	1	1 to 9/15	No	Yes	Buck	200 mV feedback voltage, fast PWM dimming
LM3405A	3 to 22	Up to 20	1	1 to 3	No	Yes	Buck	200 mV feedback voltage, fast PWM dimming, thin package
LM3406/HV	42/6 to 75	Up to 37/67	1.5	1 to 9/15	No	Yes	Buck	200 mV feedback voltage, fast PWM or two-wire dimming, true average current control
LM3407	4.5 to 30	Up to 27	0.35	1 to 7	No	Yes	Floating Buck	Constant frequency PWM with true average current control
LM3409/HV	6 to 42/6 to 75	Up to 42/75	3+	1 to 9/15	No	No	Buck	External high-side P-FET current source with differential current sensing and analog current adjust
LM3421	4.5 to 75	Adjustable	3+	1 to 16	No	No	Floating Buck	20 mV to 1.235V adjustable differential current sense voltage, 50 kHz max PWM dimming
LM3423	4.5 to 75	Adjustable	3+	1 to 16	No	No	Floating Buck	20 mV to 1.235V adjustable differential current sense voltage, 50 kHz max PWM dimming; fault timer; LED ready flag; high-side dimming
LM3433	-9 to -14	Up to 6	20+	—	No	No	Negative SYNC Buck	Negative output voltage capability allows LED anode to be tied directly to chassis for max. heat sink efficacy

Boost (Step-up) High-Brightness LED Drivers

Product ID	V _{in} Range (V)	V _{out} (V)	I _{sw} (A)	No. of LED	Multi-output	Internal SWITCH	Topology	Key Features
LM3410	2.7 to 5.5	24	2.1 ⁽¹⁾	1 to 5	No	Yes	Boost	Ultra-low stand by current of 80 nA, internally compensated
LM3431	5 to 36	40	0.15	3 x 10	Yes	No	Boost	LED protection: short, open and thermal
LM3421	4.5 to 75	Adjustable	3+	1 to 20	No	No	Boost	20 mV to 1.235V adjustable differential current sense voltage, 50 kHz max PWM dimming
LM3423	4.5 to 75	Adjustable	3+	1 to 20	No	No	Boost	20 mV to 1.235V adjustable differential current sense voltage, 50 kHz max PWM dimming; fault timer; LED ready flag; high-side dimming

Note ⁽¹⁾ Specified in ISW

Buck-Boost High-Brightness LED Drivers

Product ID	V _{in} Range (V)	V _{out} (V)	I _{sw} (A)	No. of LED	Multi-output	Internal SWITCH	Topology	Key Features
LM3410	2.7 to 5.5	24	2.1 ⁽¹⁾	1 to 5	No	Yes	SEPIC	Ultra-low stand by current of 80 nA, internally compensated
LM3421	4.5 to 75	Adjustable	3+	1 to 20	No	No	Floating Buck-Boost SEPIC	20 mV to 1.235V adjustable differential current sense voltage, 50 kHz max PWM dimming
LM3423	4.5 to 75	Adjustable	3+	1 to 20	No	No	Floating Buck-Boost SEPIC	20 mV to 1.235V adjustable differential current sense voltage, 50 kHz max PWM dimming; fault timer; LED ready flag; high-side dimming

Note ⁽¹⁾ Specified in ISW

Offline HB LED Driver Solutions

Product ID	V _{in} Range (V)	V _{out_max} (V)	I _o (A)	No. of LED	Multi-output	Internal SWITCH	Topology	Key Features
LM3445	80 to 270	Adjustable	1+	1 to 14+	No	No	Floating Buck	Integrated TRIAC dim decoder circuit for LED dimming. Adaptive programmable off-line allows for constant ripple current. No 120/100 Hz flicker

Key Products Overview

LM3401 Hysteretic PFET Controller for High-Power LED Driver

Theory of Operation

The LM3401 drives an external P-MOSFET switch for buck regulators. It delivers constant current within $\pm 6\%$ accuracy to a wide variety and number of series connected LEDs. Output current is adjusted with an external current sensing resistor to drive high-power LEDs in excess of 1A.

For improved accuracy and efficiency, the LM3401 features dual-side hysteresis, very low reference voltage, and short propagation delay. A cycle-by-cycle current limit provides protection against over current and short circuit failures. Additional features include adjustable hysteresis and a CMOS compatible input pin for PWM dimming.

Typical Application Circuit

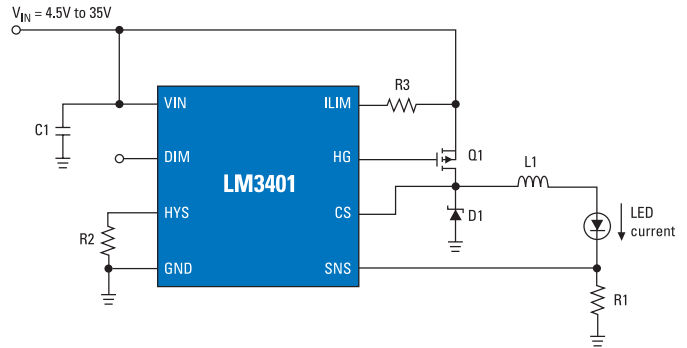

LM3406/06HV PowerWise® 1.5A Constant-Current Buck Regulator for Driving High Power LEDs

Theory of Operation

The LM3406/06HV is buck regulator with a wide-input voltage range, low-voltage reference, and a two-wire dimming functions. These features combine to make the LM3406/06HV ideal for use as a constant current source for LEDs with forward currents as high as 1.5A. The controlled on-time (COT) architecture uses a comparator and a one-shot on timer that varies inversely with input and output voltage instead of a fixed clock.

The LM3406/06HV also employs an integrator circuit that averages the output current. When the converter runs in continuous conduction mode (CCM) the controlled on-time maintains a constant switching frequency over changes in both input and output voltage. These features combine to give the LM3406/06HV an accurate output current, fast transient response and constant switching frequency over a wide range of conditions.

Typical Application Circuit

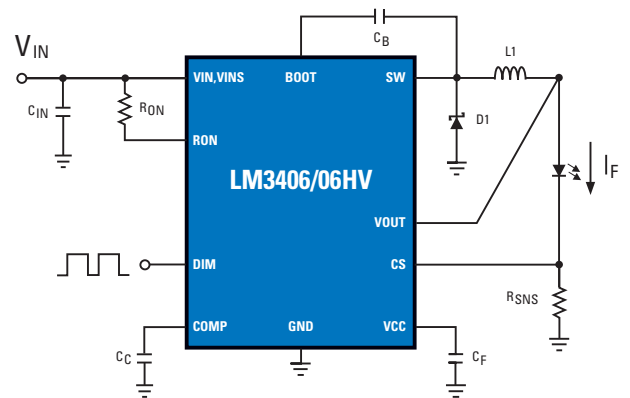

Key Products Overview

LM3431 PowerWise® 3-Channel Constant-Current LED Driver with Integrated Boost Controller

Theory of Operation

The LM3431 is a 3-channel linear current controller combined with a boost switching controller ideal for driving LED backlight panels in space critical applications. The LM3431 drives 3 external NPN transistors or MOSFETs to deliver high accuracy constant current to 3 LED strings. Output current is adjustable to drive strings in excess of 200 mA.

The boost controller drives an external NFET switch for step-up regulation from input voltages between 5V to 36V. The LM3431 features LED cathode feedback to minimize regulator headroom and optimize efficiency.

A DIM input pin controls LED brightness from analog or digital control signals. Dimming frequencies up to 25 kHz are possible with a contrast ratio of 100:1. Contrast ratios greater than 1000:1 are possible at lower dimming frequencies.

The LM3431 eliminates audible noise problems by maintaining constant output voltage regulation during LED dimming. Additional features include LED short and open protection, fault delay/error flag, cycle-by-cycle current limit, and thermal shutdown for both the IC and LED array.

Typical Application Circuit

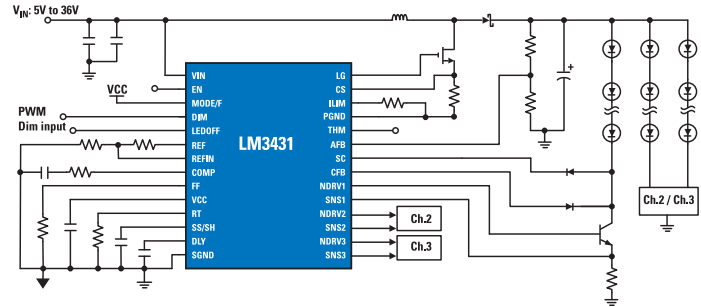

LM3433 PowerWise Common Anode Capable High-Brightness LED Driver with High-Frequency Dimming

Theory of Operation

The LM3433 is an adaptive constant on-time DC/DC buck constant current controller (a true current source). It provides a constant current for illuminating high power LEDs.

The output configuration allows the anodes of multiple LEDs to be tied directly to the ground referenced chassis for maximum heat sink efficacy. The high-frequency capable architecture allows the use of small external passive components and no output capacitor while maintaining low LED ripple current.

The PWM functions by shorting out the LED with a parallel switch allowing high PWM dimming frequencies. Additional features include thermal shutdown, V_{CC} under-voltage lockout, and logic level shutdown mode.

Typical Application Circuit

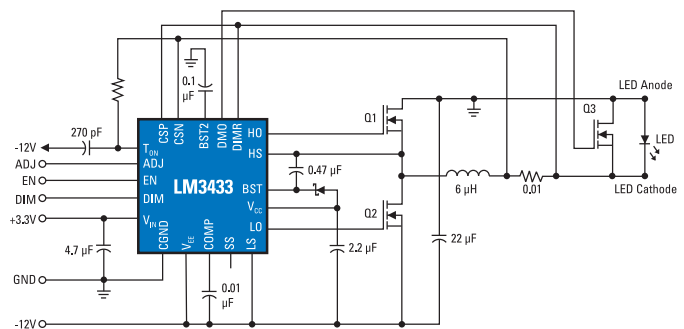

High-Brightness LED Applications

General Illumination

MR16

MR16 Basic Architecture

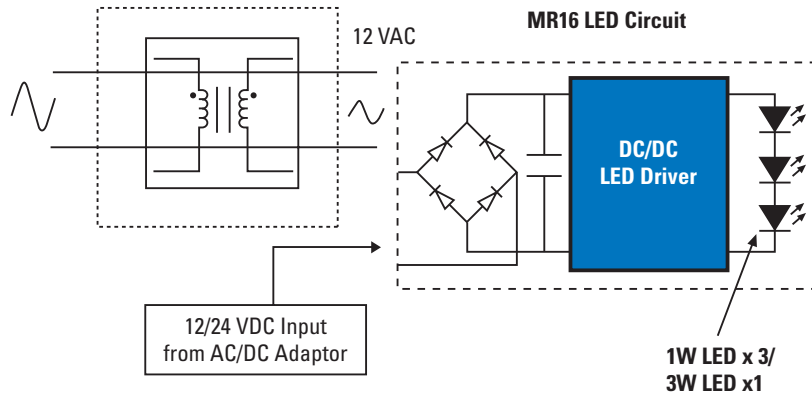

MR16 Driver Solutions

Vin	No. of LED	LED Type	I _{led} (mA)	Recommended Part No.	Key Features
12 VDC/12 VAC	3	1W	350	LM3405A XMK	Small size, tiny SOT23 package
12-24 VDC	3	1W	350	LM3407	High efficiency, high precision of LED current
12 VDC/12 VAC	1	3W	600	LM3405A XMK	Small size, tiny SOT23 package eMSOP-8
12 VDC/12 VAC	1	3W	750	LM3405A XMY	Thermally enhanced package of LM3405A
12-48 VDC	1	5W	350	LM3406	Two-wire dimming, high efficiency
12-24 VDC	3	1W	350	LM3401	100% duty cycle

Design 1: MR16 Using LM3405A

Description:

- This circuit is designed to drive a 3W High Brightness LED from an input of 12 VDC/12 VAC for halogen MR16 lamp replacement.

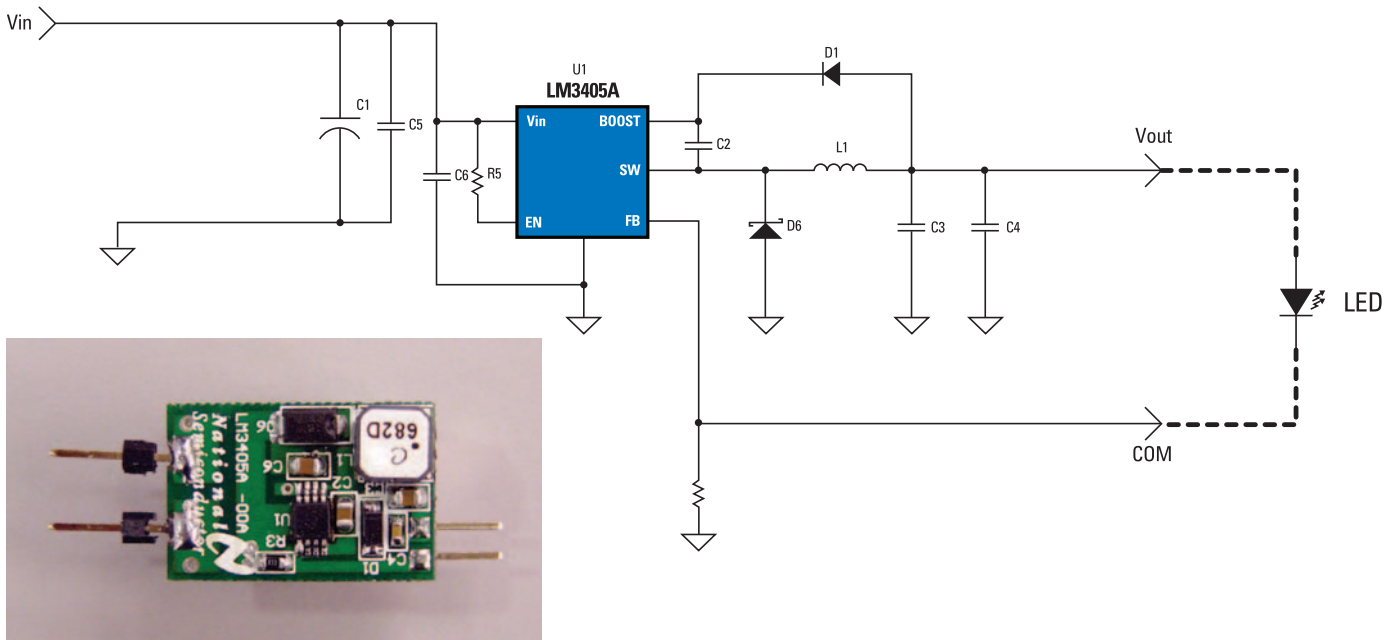

Test Data:

1: Output Voltage & Current

Parameter		Reading	
Vin	Loading	Vo	Io
12 VDC	LED = 1 pcs	3.8V	0.70A

2: Efficiency

	Reading				
Input Voltage	Vin	Iin	Vo	Io	Efficiency
12.00V	12.00V	0.274A	3.80V	0.70A	80.9%

BOM (Main Component)

Item	Designation	Description	Part No.	Vendor
1	U1	LED Driver IC, LM3405A	LM3405A (eMSOP-8)	National
2	C1	16V, 220 μ F, 8 x 7 mm	SG or YK, 220 μ F, 16V	Lelon or Rubycon
3	L1	Inductor 6.8 μ H, 0.095 Ω , 2.6A	LPS6225-682MLB	Coilcraft
4	Co	CAP0805, 0.47 μ F	GRM188R71C474KA88	Murata

High-Brightness LED Applications

General Illumination

Design 2: MR16 Using LM3407

Description:

- This circuit is designed to drive an array of 3 series-connected 1W LEDs from an input of 12 VDC/12 VAC for MR16 halogen lamp replacement.

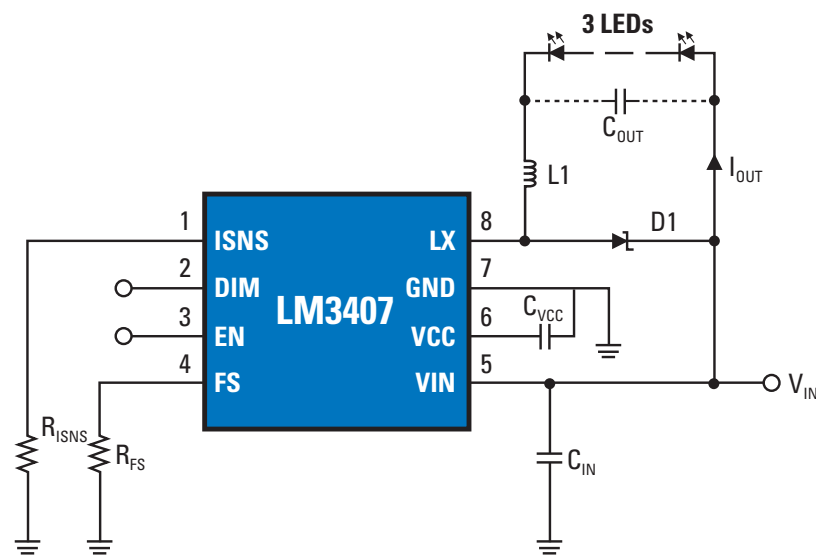
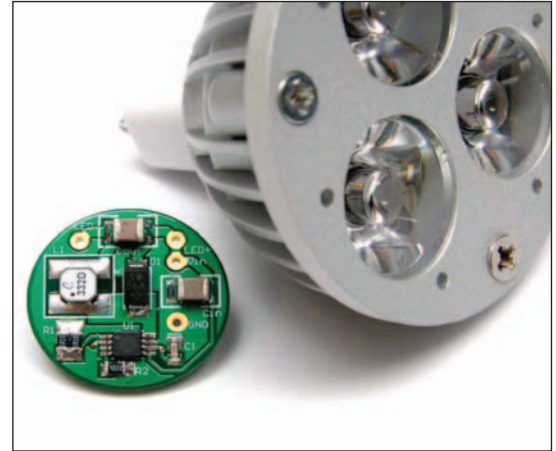

Test Data:

1: Output Voltage & Current

Parameter		Reading	
Vin	Loading	Vo	Io
12 VDC	LED = 3 pcs	9.71V	0.35A

2: Efficiency

Input Voltage	Reading				
Vin	lin	Vo	Io	Efficiency	
12.00V	12.01V	0.30A	9.71V	0.35A	94.06%

BOM (Main Component)

Item	Designation	Description	Part No.	Vendor
1	U1	LED Driver IC, LM3407	LM3407 (eMSOP-8)	National
2	L1	Inductor 33 μ H, 0.58A	LPS-4018-333ML	Coilcraft
3	Cin	Cap MLCC 50V, 4.7 μ F, X7R	GRM32ER71H475K88L	Murata
4	Cout	Cap MLCC 25V, 2.2 μ F, X7R	GRM31MR71E225MA93	Murata

Design 3: MR16 with Two-Wire Dimming Driven by the LM3406

Description:

- This circuit is designed to drive a 1.5A high-brightness LED from an input of 12 VDC for MR16 halogen lamp replacement.
- The two-wire dimming feature of LM3406 enables PWM dimming over the power input line.

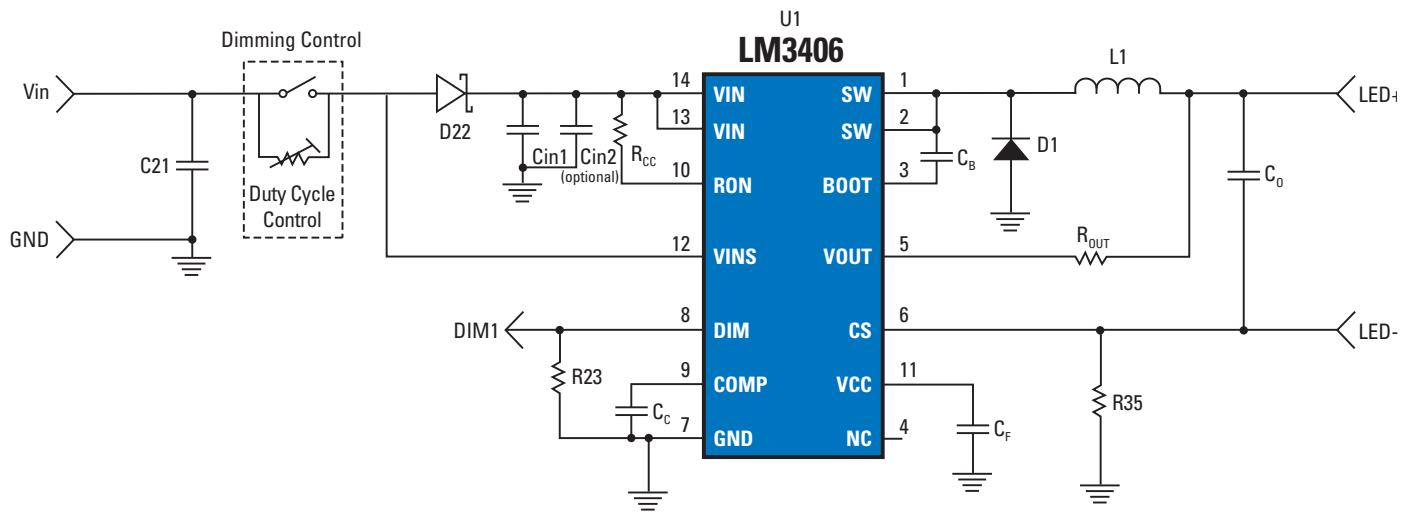

Test Data:

1: Output Voltage & Current

Parameter		Reading	
Vin	Loading	Vo	Io
12 VDC	LED = 2 pcs	4.20V	1.50A

2: Efficiency

Input Voltage	Reading				
Vin	lin	Vo	Io	Efficiency	
12.00V	12.00V	0.62A	4.20V	1.50A	84.68%

BOM (Main Component)

Item	Designation	Description	Part No.	Vendor
1	U1	LED Driver IC, LM3406	LM3406 (eTSSOP-14)	National
2	L1	15 μ H, 2.2A, 47 m Ω	SLF10145T-150M2R2-P	TDK
3	Cin1	3.3 μ F, 50V	C3225X7R1H335M	TDK
4	Co	0.15 μ F, 50V	C3216X7R1H105M	TDK

High-Brightness LED Applications

General Illumination

QR111, PAR30 and PAR38

Description:

- This circuit is designed to drive an array of 5-8 series-connected 3W LEDs from an input of 12 VDC/12 VAC for existing QR111, PAR30/38 luminaire form factor.
- Since the total forward voltage of the LED string is higher than the input voltage, the step-up (boost) topology with LM3421 is employed.

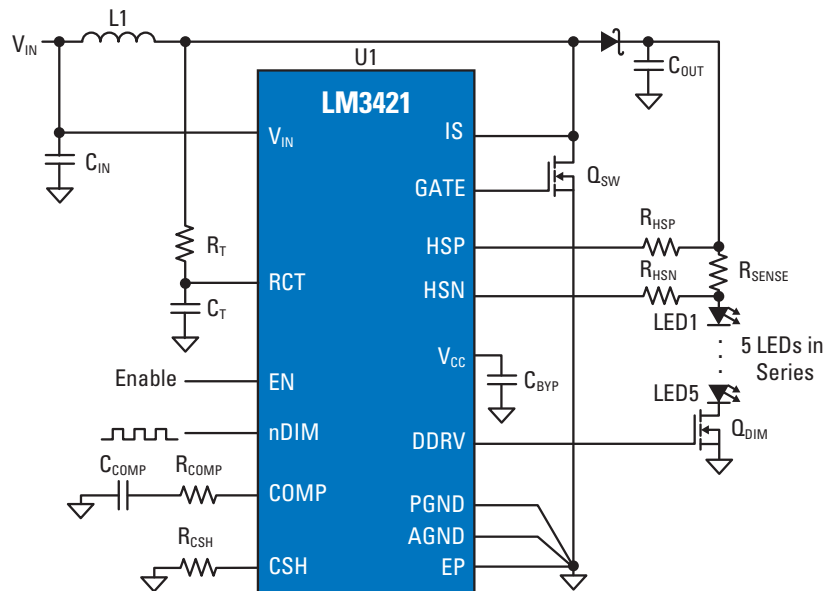

Test Data:

1: Output Voltage & Current

Parameter		Reading	
Vin	Loading	Vo	Io
12 VDC	5 LEDs	19.98V	0.72A

2: Efficiency

	Reading				
Input Voltage	Vin	Iin	Vo	Io	Efficiency
12.00V	12.00V	1.27A	19.98V	0.72A	94.50%

BOM (Main Component)

Item	Designation	Description	Part No.	Vendor
1	U1	Low-side controller for constant-current LED drivers	LM3421 (TSSOP-16)	National
2	L1	15 µH	7447709150	Coilcraft
3	Cin	150 µF/50V	Aluminum electrolytic capacitor, EEEFK1H151P	Panasonic
4	Cout	150 µF/50V	Aluminum electrolytic capacitor, EEEFK1H151P	Murata

48V Bus Street Lamp

LED Street Lamp Architecture

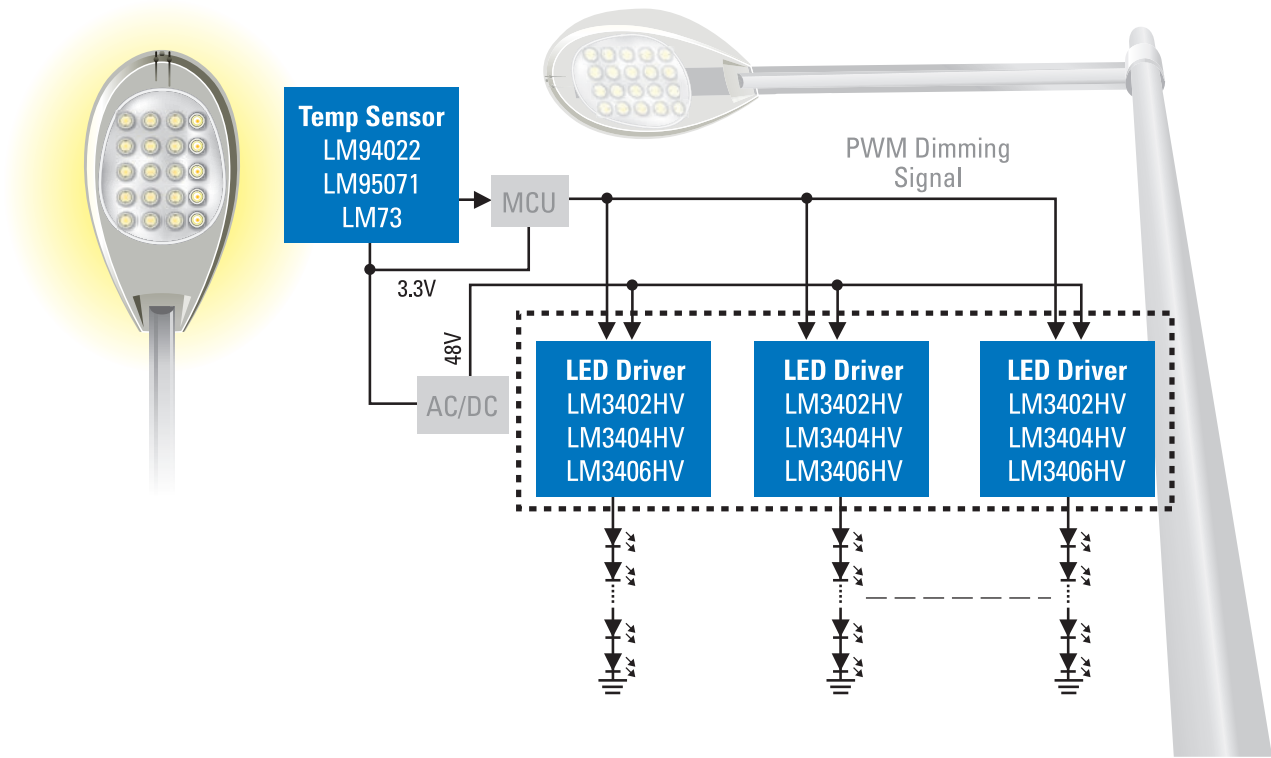

Key Benefits of LM3402/4/6HV in 48V (or higher) Bus LED Street Lamp System

- High operating V_{in} buck LED driver
 - Maximize the number of LEDs per string (~10 – 12 LEDs in series for 1 LED driver)
 - Lower total system solution cost
- Ultra-high-efficiency LED driving solution
 - 96% + efficiency with 10 LEDs connected in series
 - Enhanced thermal performance in the harsh streetlamp working environment
- Integrated FET LED driver, and no compensation is required
 - Easy to use

High-Brightness LED Applications

General Illumination

Street Lamp

Design 1: 1W LED String Using LM3402HV

Description:

- This circuit is designed to drive an array of 10-12 series-connected 1W LEDs from the source of 48V output AC/DC SMPS.
- Multiple LM3402HV LED drivers are used in the LED streetlamp system, depending on the streetlamp's output wattage.
- Each LM3402HV LED driver provides constant current for a single LED string. This enables consistent brightness of each LED in the LED streetlamp.

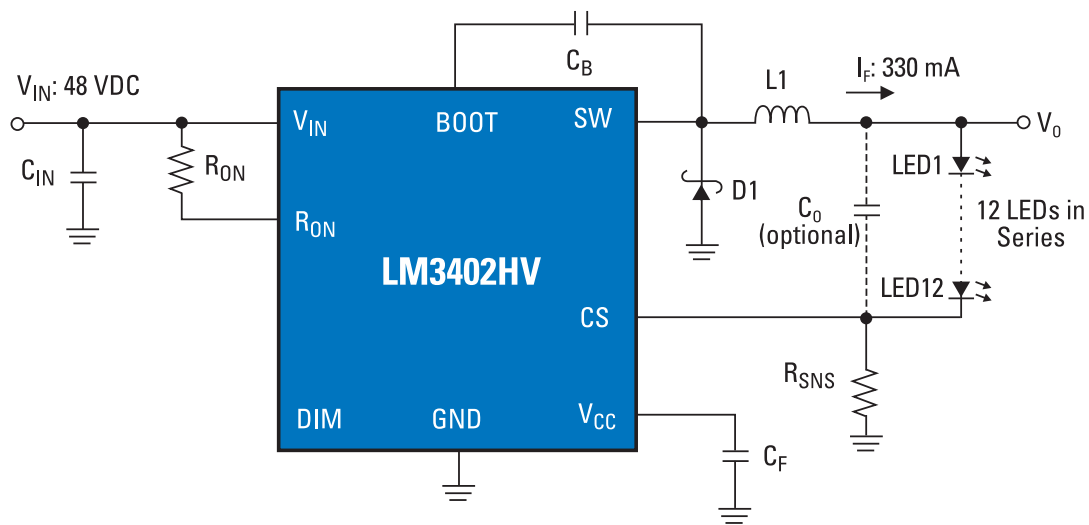

Test Data:

1: Output Voltage & Current

Parameter		Reading	
Vin	Loading	Vo	Io
48 VDC	LED = 12 pcs	38.20V	0.33A

2: Efficiency

		Reading				
Input Voltage	Vin	Iin	Vo	Io	Efficiency	
48.00V	47.91V	0.27A	38.20V	0.33A	98.04%	

BOM (Main Component)

Item	Designation	Description	Part No.	Vendor
1	U1	75V, 0.5A LED Driver	LM3402HV (SO-8 or PSOP8)	National
2	L1	18.5 x 15.4 x 7.1 mm 330 μ H, 1.9A, 0.56 Ω	D05022P-334	Coilcraft
3	Cin	2.2 μ F/100V/1812	C4532X7R2A225M	TDK
4	Co	0.15 μ F, 100V, 1206	C3216X7R2A154M	TDK

Design 2: 3W LED String Using LM3404HV

Description:

- Designed to drive an array of 10-12 series-connected 3W LEDs from a 48V output AC/DC SMPS.
- Multiple LM3404HV LED drivers are used in the LED streetlamp system, depending on the streetlamp's output wattage.
- Each LM3404HV LED driver provides constant current for a single LED string. This guarantees consistent brightness of each LED in the LED streetlamp.

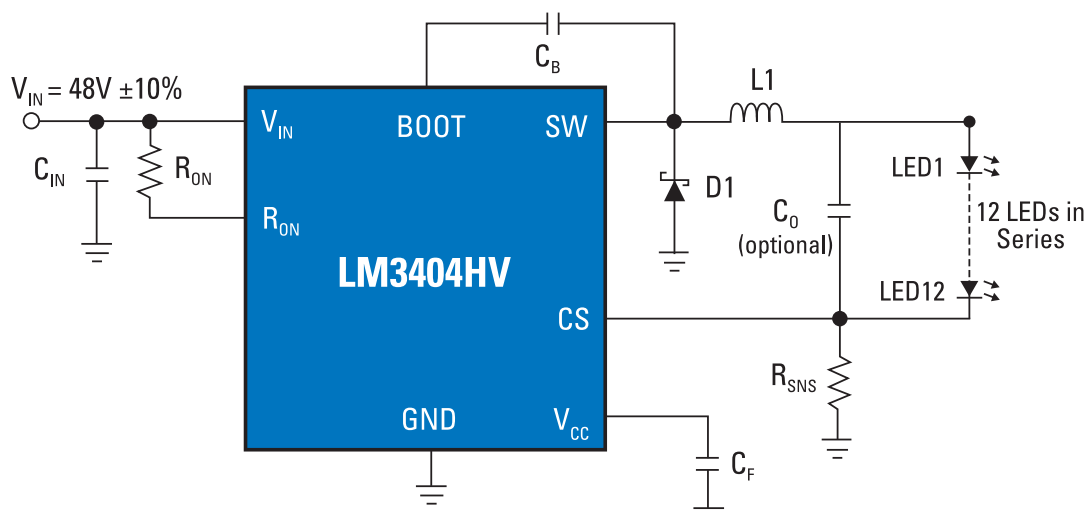

Test Data:

1: Output Voltage & Current

Parameter		Reading	
Vin	Loading	Vo	Io
52 VDC	LED = 12 pcs	41.975V	1.071A

2: Efficiency

Input Voltage	Reading				
	Vin	Iin	Vo	Io	Efficiency
52.00V	51.97V	1.017A	41.975V	1.017A	96.97%

BOM (Main Component)

Item	Designation	Description	Part No.	Vendor
1	U1	75V, 1.2A LED Driver	LM3404HV (SO-8 or PSOP8)	National
2	L1	Inductor 220 μ H, 0.229 Ω , 2.2A	MSS1278-184KL	Coilcraft
3	Cin	2.2 μ F/100V/1812	C4532X7R2A225M	TDK
4	Co	0.15 μ F, 100V, 1206	C3216X7R2A154M	TDK

High-Brightness LED Applications

LED Light Source for Office Equipment

Portable Projector

- The LM3433 is a high-power constant-current LED driver controller which employs a negative synchronous buck topology, perfect for applications where a common anode LED system is used for high current output.
- An example power architecture of a portable projector using LM3433 is shown below. The -12 VDC isolated AC/DC SMPS is used for powering LM3433 LED drivers while the floating buck-boost LM3481 is used to generate positive outputs for other logic and interface.

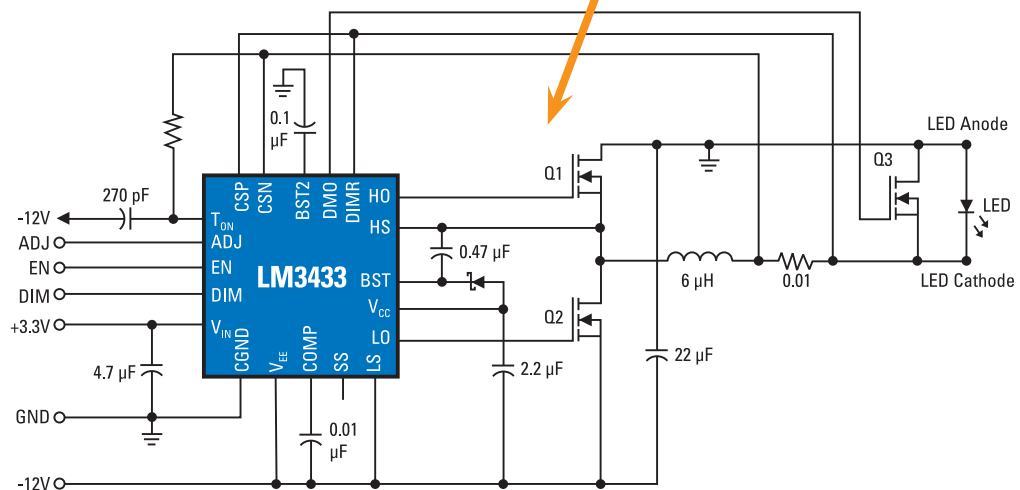
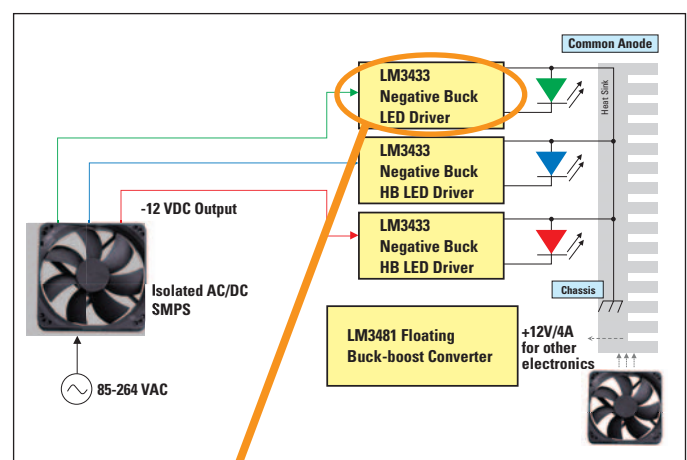
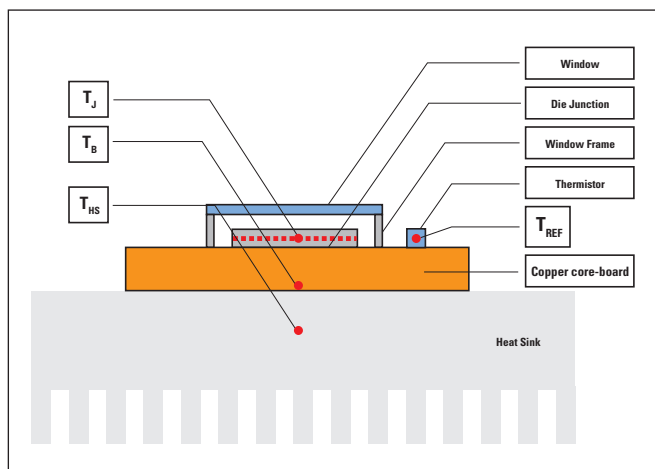

LED Projector Using LM3433

Description:

- Designed to drive a high-brightness common anode LED module from a -12 VDC source derived from an isolated AC/DC SMPS for portable projector applications.
- In LED-based portable projector systems, green, blue and red high-brightness common anode LED modules are used as light sources. Each color requires one LM3433 driver.

Typical Application Circuit

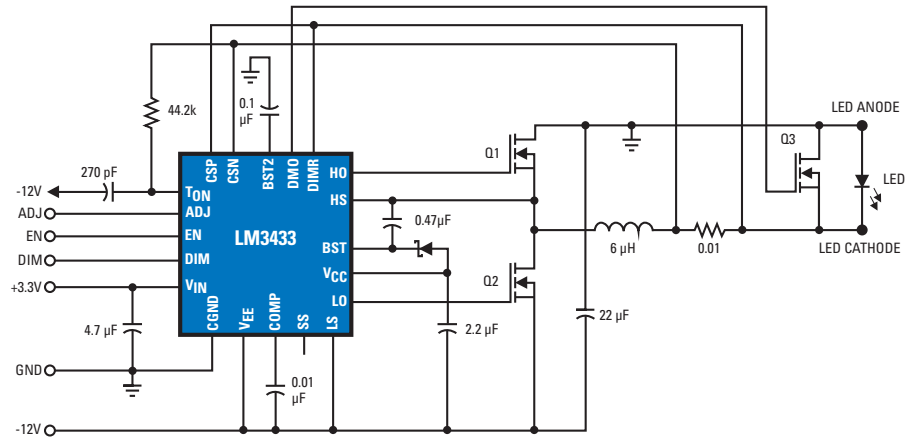

Test Data:

1: Output Voltage & Current

Parameter		Reading	
Vin	Loading	Vo	Io
-12 VDC	LED = 1 pcs	4.60V	6.00A

2: Efficiency

Input Voltage	Reading				
Vin	Iin	Vo	Io	Efficiency	
-12.00V	-12.00V	2.47A	-4.60V	6.00A	93.00%

BOM (Main Component)

Item	Designation	Description	Part No.	Vendor
1	U1	Common Anode Capable High Brightness LED Driver with High Frequency Dimming	LM3433 (LLP-24)	National
2	L2	12 µH, 14A	GA3252-AL	Coilcraft
3	C3	150 µF, 16V	16SA150M	MULTICAP
4	C4	1210 22 µF x 2, 16V	GRM32ER61C226KE20L	Murata
5	C6	1210 47 µF, 16V	GRM32ER61C476ME15L	Murata
6	MOSFET (Q1,Q2,Q3,Q4)	PowerPAK 30V, 9.5 mΩ	Si7386DP	Vishay
7	LED	6A	PT39	Luminus

High-Brightness LED Applications

LED Light Source for Office Equipment

Scanner/Multi-function Printer

- Traditionally, CCFLs have been widely used as a light source for multi-function printers even though it requires longer warm-up time before the image scanning process can begin, especially when the MFP has just powered up or is in energy saving mode.
- CCFL is not an environmentally friendly light source due to the mercury inside. This is why high-brightness LEDs are used as the light source for new model MFPs.
- A comparison between a CCFL and an LED in MFP light source applications is shown below.

Conventional Light Source vs LED

	CCFL	LED
Efficiency	Good (50 lm/W~)	Good (50 lm/W~)
Brightness	Low	Depends on Current and Number of LEDs
Start up	Slow	Fast
Dimming	NA	Available

More Advantages of LEDs:

- Longer life time
- No hazardous materials
- Easier to drive

General scanning action on MFP, copier or scanner

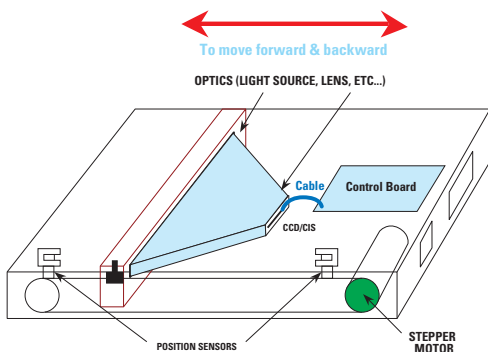

Side-Lit LEDs Scanning Light Bar



Side Lit LEDs

- 1 side or both sides
- 1 or 2 LED at each side

Back-Lit LEDs Scanning Light Bar

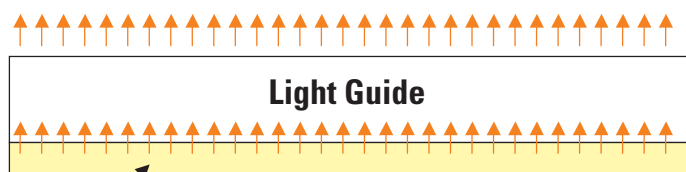

LED Array

The brightness variation of each LED is a problem

Design 2: Scanner/MFP Using LM3402

Description:

- Designed to drive multiple strings of 6 series-connected LEDs from 24V AC/DC adapter for scanner/MFP application to replace the conventional CCFL lamp.

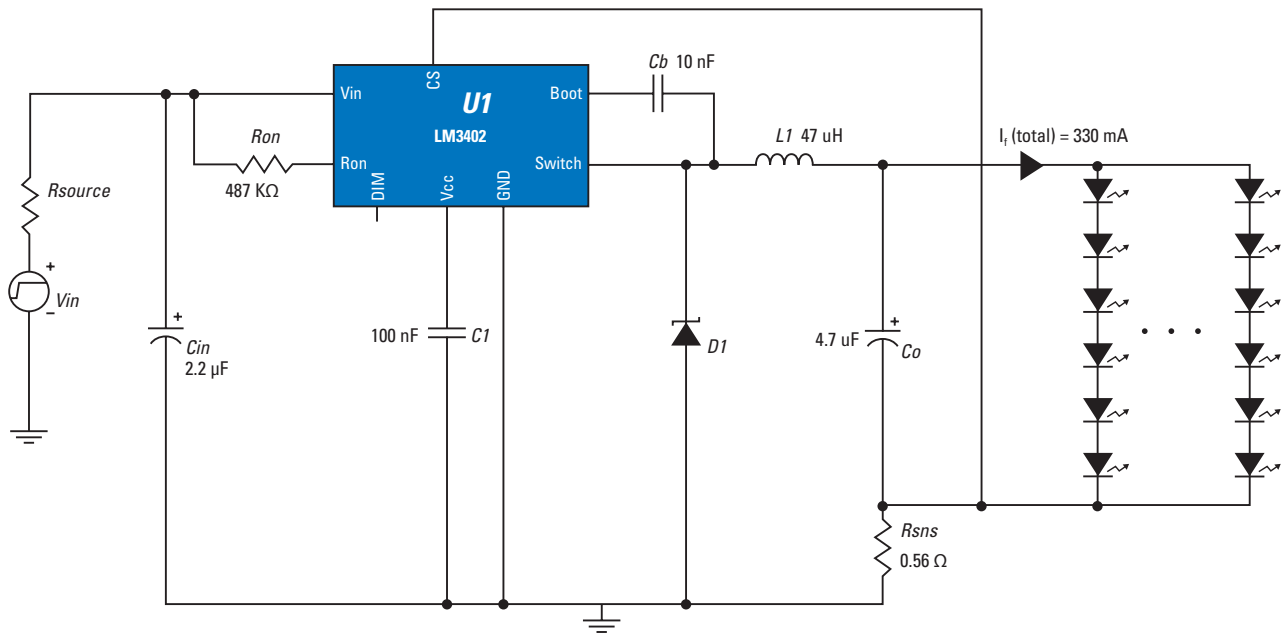

* For the above configuration of LED array, binning of Vf may be required to balance the current of each LED.

Test Data:

1: Output Voltage & Current

Parameter		Reading	
Vin	Loading	Vo	Io
24 VDC	Multiple strings of 6 series-connected white LEDs	20.4V	330 mA

2: Efficiency

Input Voltage	Reading				
Vin	Iin	Vo	Io	Efficiency	
24 VDC	24V	0.293A	20.4V	330 mA	95.8%

BOM (Main Component)

Item	Designation	Description	Part No.	Vendor
1	U1	42V, 0.5A LED Driver	LM3402 (SO-8)	National
2	Cin	2.2 μF	C3225X7R1H225M	TDK
3	L1	47 μH, 0.15Ω	SLF7045T-470MR75	TDK
4	Co	4.7 μF	C3225X7R1E475M	TDK

High-Brightness LED Applications

Automotive Lighting

From headlights to LCD backlighting in infotainment systems, LEDs are an integral part of the driving experience. National's portfolio of LED drivers offer key features like PWM dimming, accurate Under Voltage Lockout (UVLO), and high-side current sensing. Plus, low

LED ripple current and external oscillator sync capabilities allow designers to reduce issues with EMI. These LED drivers provide maximum efficiency and effectiveness in any automotive lighting system.

Features	Benefits
High efficiency	Better thermal management
High-side current sensing	LEDs grounded to chassis for better thermal dissipation
Accurate current control	Extends LED lifetime
PWM and analog dimming	Easily reduces current when battery is low to avoid excessive battery drain
Wide-voltage range	Stable under instant on, low and high battery, high voltage transients
External oscillator sync capability	External spread spectrum for low EMI

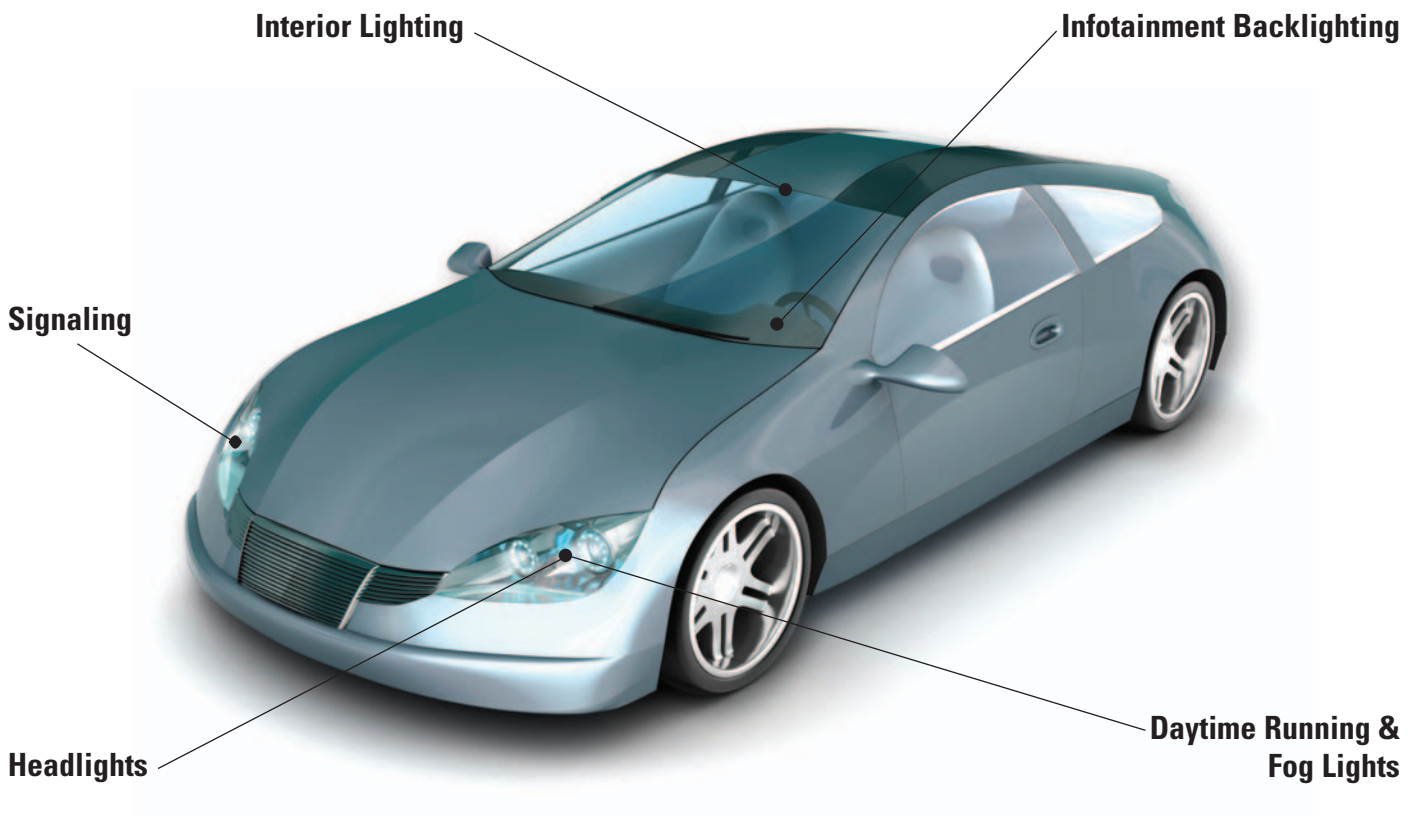

Design 1: Driving Daytime Running Lamp (DRL) with LM3423 Boost LED Driver

Description:

- Designed to drive a single string of 12 series-connected 1W LEDs from the battery input for daytime running lamps (DRL) in passenger cars.
- Since the total forward voltage of the LED string is higher than the battery input voltage, a boost (step-up) LED driver is required.

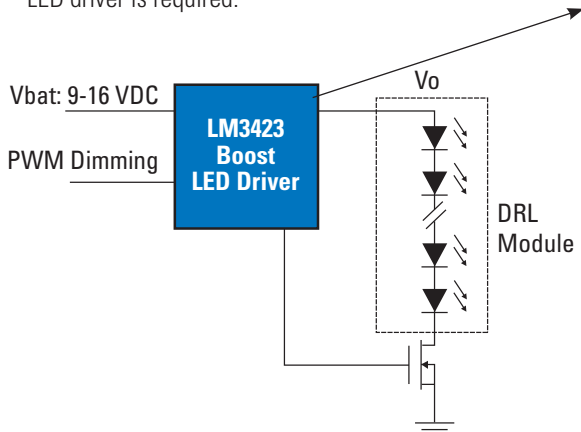

DEMO Board

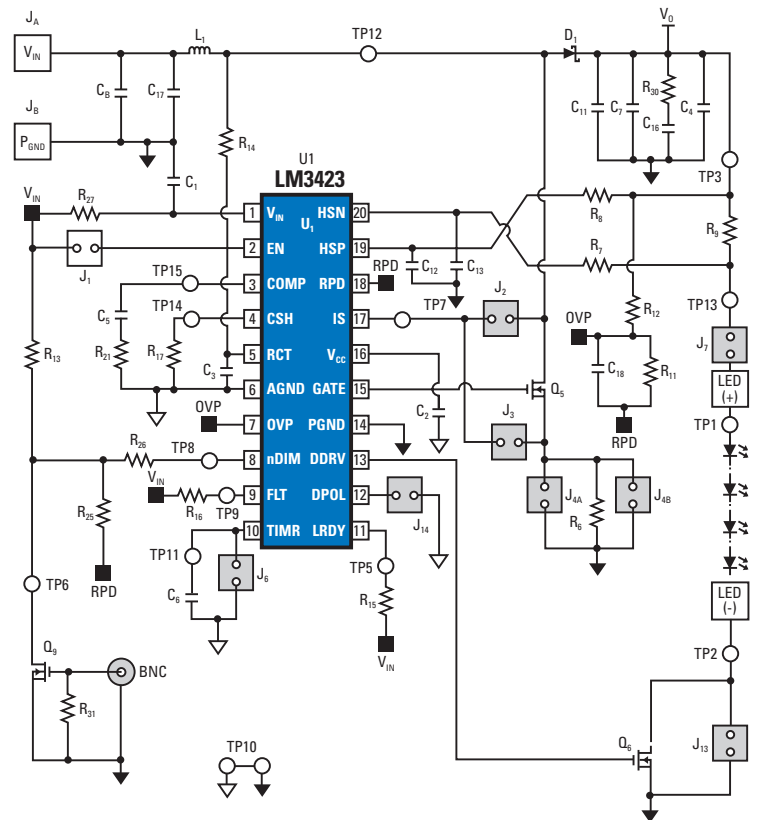

LM3423 DEMO Board Test Data:

1: Output Voltage & Current

Parameter		Reading	
V _{in}	Loading	V _o	I _o
12 VDC	LED module	46.00V	0.40A

2: Efficiency

		Reading				
Input Voltage	V _{in}	I _{in}	V _o	I _o	Efficiency	
12.00V	12.00V	1.65A	46.00V	0.40A	92.93%	

BOM (Main Component)

Item	Designation	Description	Part No.	Vendor
1	U1	Low-side controller for constant-current LED drivers	LM3423 (TSSOP-20)	National
2	L1	22 µH	DO5040H	Coilcraft
3	C8 (Cin)	330 µF, 35V 5 mm	ECA-1VM331	Panasonic
4	C7 (Cout1)	330 µF, 35V 5 mm	ECA-1VM331	Panasonic
5	C11 (Cout2)	1210 10 µF, 25V	ECJ-4YB1E106M	Panasonic

High-Brightness LED Applications

Automotive Lighting

Design 2: Headlamp Using LM3423 Buck-Boost LED Driver

Description:

- Designed to drive a single string of 6 series-connected 3W LEDs from both a 12V and a 24V bus battery input for automotive headlamp applications.
- Since the total forward voltage drop of the LED string can be either higher or lower than the input voltage, a buck-boost LED driver is required.

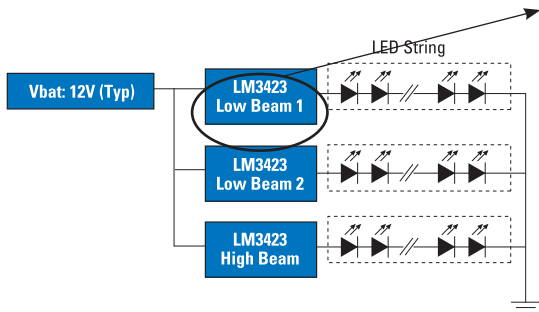

Demo Board Schematic

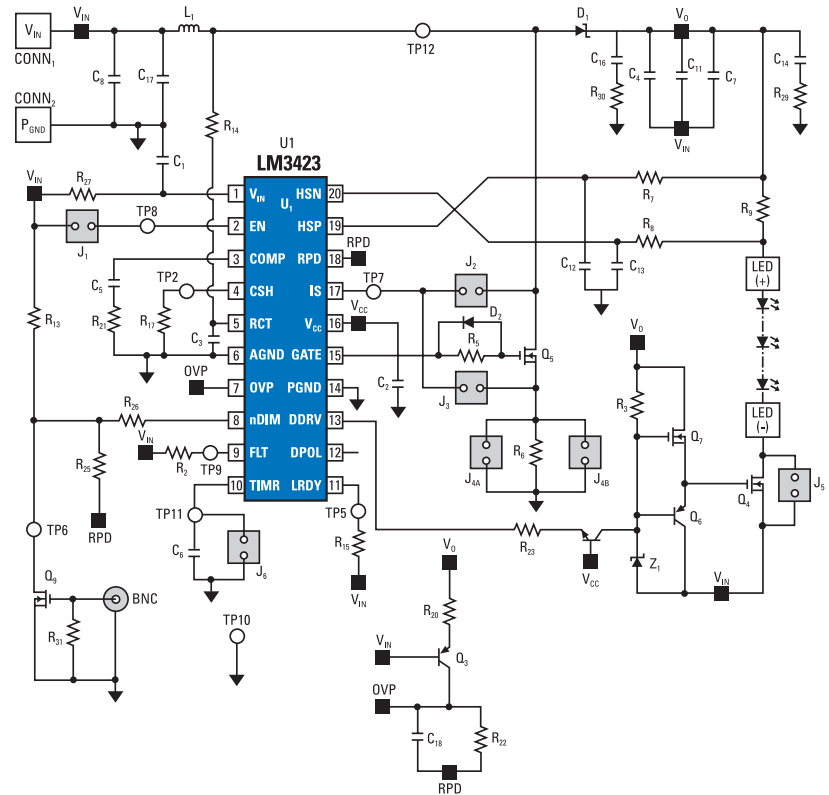

Floating Buck-Boost Demo Test Data:

1: Output Voltage & Current

Parameter		Reading	
V _{in}	Loading	V _o	I _o
6-32 VDC	20V at 1A	20.00V	1.00A

2: Efficiency

Input Voltage	V _{in}	I _{in}	V _o	I _o	Efficiency
12.00V	12.00V	1.87A	20.00V	1.00A	88.98%
24.00V	24.00V	0.93A	20.00V	1.00A	89.51%

BOM (Main Component)

Item	Designation	Description	Part No.	Vendor
1	U1	Buck-boost controller for constant-current LED drivers	LM3423 (TSSOP-20)	National
2	L1	22 µH	DO5040H	Coilcraft
3	C8 (Cin)	330 µF/35V 5 mm Lead	ECA-1VM331	Panasonic
4	C7 (Cout1)	330 µF/35V 5 mm Lead	ECA-1VM331	Panasonic
5	C11 (Cout2)	1210 10 µF, 25V	ECJ-4YB1E106M	Panasonic

Design 3: LED Backlighting Applications Using LM3431

LED Backlighting for TFT Displays



LED Backlighting for Dashboards



Description:

- Designed to drive four channels of 8 series-connected 140 mA LEDs from a 12V bus battery input for automotive LED backlighting in a TFT display.

Vin: 8-18V, 4 strings of 8 LEDs, 140 mA per string.

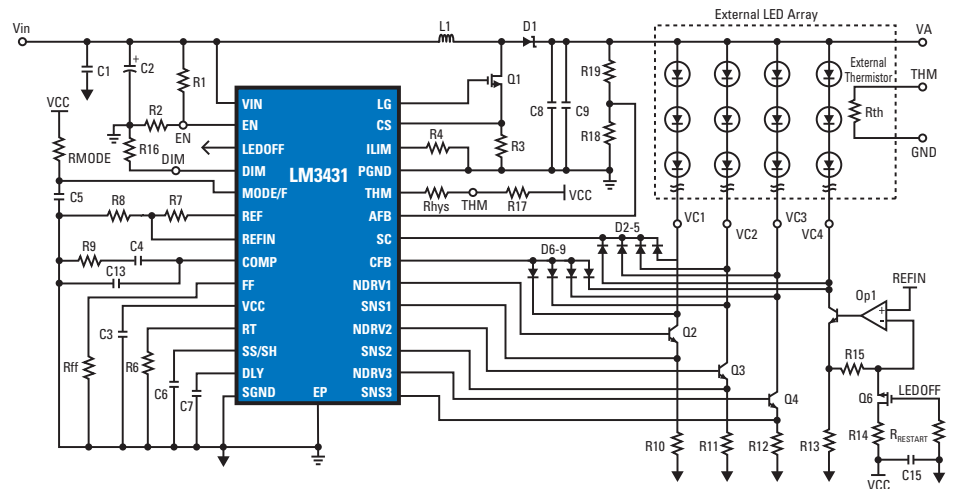

Test Data:

1: Output Voltage & Current

Parameter		Reading	
Vin	Loading	Vo	Io
8-18 VDC	4 strings of 8 pcs LED, Vf: 3.2V	25.60V	0.14A

2: Efficiency

Input Voltage	Reading				
	Vin	Iin	Vo	Io	Efficiency
12.00V	12.00V	0.34A	25.60V	0.14A	88.00%

BOM (Main Component)

Item	Designation	Description	Part No.	Vendor
1	U1	Boost controller for multi-channel constant-current LED drivers	LM3431 (TSSOP-28)	National
2	L1	7 μ H 3.1A inductor	MSS1038-702NL	Coilcraft
3	C2 (Cin_1)	10 μ F 50V electrolytic	UUD1H100MCL	Nichicon
4	C1 (Cin_2)	1 μ F 50V B ceramic	GRM32RB11H105KA01	Murata
5	C3 & C8 (Cout)	2 x 4.7 μ F 50V X7R ceramic	GRM32ER71H475KA88L	Murata
6	Q1	60V 200 mA N-channel MOSFET	2N7002K	Vishay

High-Brightness LED Applications

TRIAC Dimming

TRIAC Dimmable LED Lamp Using LM3445

- The TRIAC phase-control dimmer is today's most popular and common dimming method, but it is designed to interface to a purely resistive load, such as incandescent or halogen light bulbs. Since an LED does not appear as a resistive load to the TRIAC dimmer, dimming an LED using a conventional TRIAC wall dimmer does not achieve good dimming performance.
- National's newly released LM3445 TRIAC dimmable offline LED driver, overcomes the issue and enables LEDs to be used as a direct replacement for incandescent or halogen lamp systems which are currently interfaced to a TRIAC wall dimmer. The LM3445 is an offline solution that offers 100:1 full range uniform dimming capability, is free of flicker at 100/120 Hz, and supports Master/Slave Operation.

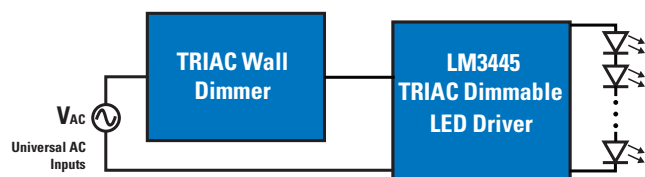

Design 1: TRIAC Dimmable LED Lamp with LM3445

Description:

This design is configured to support 90 VAC to 135 VAC inputs to drive 7 or 8 series-connected LEDs at an average current of 350 mA for TRIAC dimmable LED lamp applications.

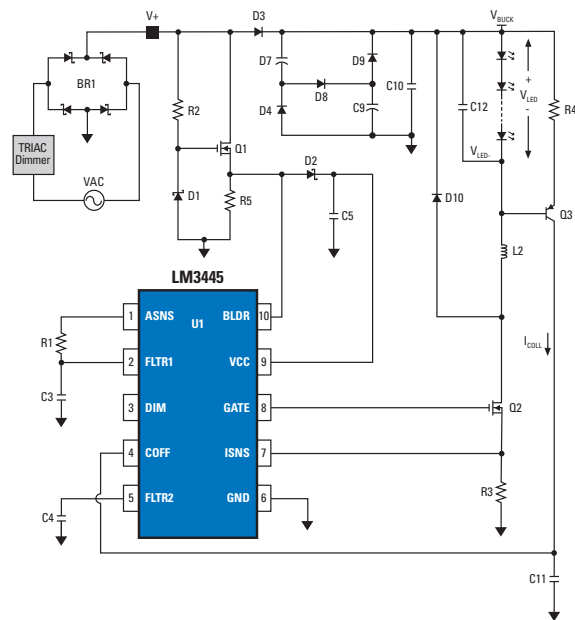

Test Data:

1: Output Voltage & Current

Parameter		Reading	
Vin	Loading	Vo	Io
110 VAC	LED = 12 pcs	46 VDC	0.35A

2: Efficiency

Input Voltage	Reading				
	Vin	Iin	Vo	Io	Efficiency
110 VAC	—	—	46.0V	0.35A	84.20%

BOM (Main Component)

Item	Designation	Description	Part No.	Vendor
1	U1	IC, LED driver controller, MSOP10	LM3445MM	National
2	BR1	Bridge Rectifier, SMT, 400V, 800 mA	HD04-T	Diode
3	L2	Inductor. SHLD. SMT, 1A, 470 µH	Coilcraft	MSS1260-474KLB
4	C7, C9	Cap, AL, 200V, 105C, 20%, 33 µF	UCC	EKXG201ELL330MK15L
5	D4, D9	Diode, FR, SOD123, 200V, 1A	Rohm	RF071M2S
6	D10	Diode, FR, SMB, 400V, 1A	On Semi	MURS140T3G
7	Q1, Q2	XSTR, NFET, DPAK, 300V, 4A	Fairchild	FQD7N30TF

Light Matters Part 1: The ABC's of LEDs

— By Sameh Sarhan & Chris Richardson, Applications Engineer

Introduction

Light and lighting represent basic and crucial elements in the life of humankind. The pursuit of new lighting sources has been a trend of our civilization. This pursuit is generally driven by technological advancements, needs, challenges, and, sometimes, by luxury. Now that we are waking up to realize the consequences of abusing our world's limited resources, the push towards energy conservation has come to be a mandate, not a choice. Therefore, our world's current challenge is how to balance between the needs of our modern, possibly spoiled, lifestyle and the necessity to 'go green'. When it comes to lighting, it is quite easy to imagine the impact of globally improving the efficiency of lighting sources by 10%. But what if it could be improved by 1000%? The use of newly enhanced Light Emitting Diodes (LEDs) as lighting sources has the potential to achieve these efficiency improvements while maintaining outstanding performance and reliability that supersede many of the currently used sources. Part One of this two part series sheds some light on the basics of LEDs physical structure, colors, efficiency, applications, and drivers.

Anatomy

The physical anatomy of LEDs resembles p-n junction diodes. As in p-n junctions, the electrons and the holes flow towards the junction when a positive differential voltage is applied between the anode (p-side), and cathode (n-side). Once an electron is recombined with a hole, it releases energy. Depending on the physical properties of the p-n junction materials, the released energy can be non-radiative, as in normal diode materials, or may produce optical emissions in the form of photons with LED materials. For an LED, the wavelength of the emitted light (its color) depends on the band gap characteristics of its p-n junction material. Performance-wise, LED materials have

relatively low reverse breakdown voltages since they have relatively low band gaps.

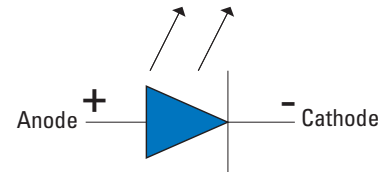
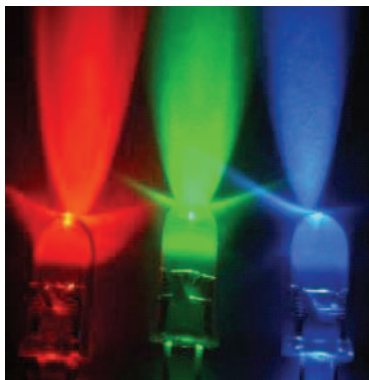

Figure 1: LED Symbol

Colors

Red LEDs were the first to become commercially available in late 1960s, and, as one acquaintance put it: "A dark cave was needed to see the light". Despite the low light output, they were commonly used in seven segment displays. Thanks to the advancements in material science, nowadays LEDs are commercially available in a variety of colors with some of them having light outputs that would blind you if you stared directly at them. (Please do not try that at home!)

My favorite color, blue, became widely available a few years ago. Mixing blue LEDs with red and green LEDs produces white light (think triad pixel). This technique of generating white light provides a large color gamut, dynamic light tuning, and excellent color rendering (CRI), which is well suited for high-end backlighting applications. A simpler and more economical way of producing white light is to use blue LEDs and a phosphor coating that converts some of the blue light to yellow. The yellow light stimulates the red and green receptors of the eye, therefore, mixing the blue and yellow lights gives the appearance of white. This scheme can provide good CRI but the LED's light output may suffer from inconsistent color temperatures due to manufacturing discrepancies and varying thicknesses in the phosphor coating layer.



Wavelength (nm)	Color Name	Fwd Voltage (V, @ 20 mA)	LED Dye Material
940	Infrared	1.5	GaAlAs/GaAs – Gallium Aluminum Arsenide/Gallium Arsenide
635	High Eff. Red	2	GaAsP/GaP – Gallium Arsenic Phosphide/Gallium Phosphide
570	Super Lime Green	2	InGaAlP – Indium Gallium Aluminum Phosphide
430	Ultra Blue	3.8	SiC/GaN – Silicon Carbide/Gallium Nitride
8000K	Cool White	3.6	SiC/GaN – Silicon Carbide/Gallium Nitride

Figure 2: LED's Color Chart for the Basic Colors

Designer's Corner

Efficiency

High efficiency has been the buzz word for LED-based light sources. When it comes to lighting, efficiency is defined as the light output per unit power. Thus, in the metric system, it is measured as lumens (lm) per watt (W). Recently some LED manufactures introduced LEDs with promised efficiencies hitting the 150 lm/W mark. In comparison, incandescent comes at 15 lm/W, and fluorescent provides 70 lm/W. So could LEDs put incandescent and fluorescent out of business any time soon? Maybe, but, unfortunately some of these LED's efficiency numbers are subject to specmanship. Here is the problem: the LED inefficiency has to do more with the fact that a considerable portion of the produced light is reflected at the surface of the packing material back into the LED die. This reflected light is likely to be absorbed by the semiconductor material and turned into heat. Utilizing anti-reflection coating and minimizing the reflection angles by using a half-sphere package with the LED placed at the center reduce the amount of reflected light and improve efficiency. However, these techniques are subject to manufacturing variations and may require high premiums to ensure a consistent performance. Otherwise, you can always opt out to specmanship to show off! In a nut shell, there is a rapidly-increasing adoption of LEDs by the electronics industry, but the change is far from complete.

Applications

There are many factors which make LEDs eye-catching for high-performance modern electronics. For example, their higher light output per watt is well suited for portable applications as it extends the battery life. On the other hand, LEDs' fast turn-on/turn-off characteristics fit perfectly with automotive tail lights needs, especially the brake lights, since it improves safety by providing drivers more response time. Using RGB LEDs in backlighting complies with ROHS standards, since LEDs do not contain lead or mercury. LED lighting facilitates a full-spectrum light source with larger color gamut. LEDs have an exceptionally long life span which enables their use in applications where long term reliability is highly desirable, such as traffic lights. Machine vision systems require a focused, bright, and homogeneous light source – LEDs are a great match. LEDs, with their simple-to-implement dynamic light-tuning, would also allow you to set the light in your living room to green when you need to relax and to red when it's time for bullfighting.

Drivers

LEDs are inherently current-driven devices since their brightness varies with their forward current, I_f . Depending on the color as well as the forward current, the LEDs' forward voltage drop, V_f , varies as well. Thus, driving LEDs with a constant current is essential to achieve the desired color and brightness level. An LED driver scheme can be as simple as a voltage source and a ballast resistor (**Figure 3A**). This solution works

best for narrow-input range, low-current applications in which the LED's forward voltage drop is slightly below the input supply voltage. Variations in the input supply voltage or the LED forward voltage drop will increase the LED current and, therefore, the light intensity and the color will shift. Linear regulators can be used to provide tighter LED current control in small step-down ratio applications (**Figure 3B**). In the case of low-current step-up requirements, switching capacitor circuits can be utilized (**Figure 3C**).

For wide-input range, high-current applications, simple driver schemes such as those mentioned above will yield high power dissipation and poor efficiency. For example, a linear regulator based LED driver yields 70% efficiency when supplying 1A from a 5V input source to a typical white InGaN LED ($V_f = 3.5V$). Under the same operating conditions, the driver's efficiency will drop to approximately 30% when the input voltage increases to 12V. In addition to degrading the overall performance of an LED based application, such poor efficiencies would require impractical thermal management schemes.

Consequently, more efficient and relatively more complex solutions such as switching regulators would be needed (**Figure 3D**). Switching regulators process power by interrupting the power flow and controlling the conversion duty cycle which results in pulsating current and voltage. They can be configured in isolated and non-isolated configurations to realize voltage or current step-down (buck), step-up (boost) or both (buck-boost) functions.

In general, a switching-regulator topology is selected based on a tradeoff between cost and desired performance at a given power conversion requirement. On the other hand, in order to properly drive LEDs, the switching regulators should be configured as constant current sources.

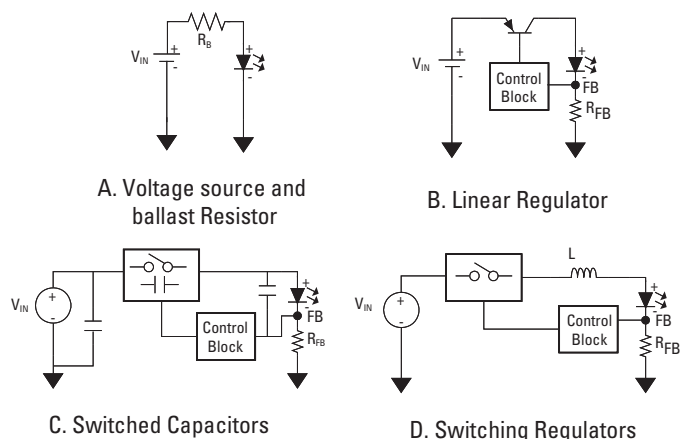

Figure 3: Simplified LED Drivers Schemes

Switching Regulators

To improve the conversion efficiency, switching regulators interrupt the power flow while controlling the conversion duty cycle to program the desired output voltage or output current. Interrupting the power flow results in pulsating current and voltage and therefore it necessitates the use of energy storage elements (inductors and/or capacitors) to filter these pulsating waveforms. Contrary to linear regulators, switching regulators can be configured in different arrangements to realize voltage or current step-down (buck), step-up (boost) or both (buck-boost) functions. They are also capable of achieving high conversion efficiencies across wide input/output range. Replacing the linear regulator with a buck-based LED driver in the previous example yields 95% to 98% efficiency across 5V to 12V input range. The configuration flexibility and the efficiency improvements of switching regulators come at the expense of higher noise generation caused by the periodic switching events, as well as higher premiums and reduced reliability due to their perceived complexity. Utilizing switching regulators to drive constant current LEDs favors regulator topologies that can be simply configured as a constant-current source. The selected topology should also combine high performance with minimum component-count to increase the driver's reliability and to reduce cost. It should also facilitate the use of various dimming techniques to take advantage of the LEDs dynamic light tuning characteristic. Fortunately, the most basic step-down (buck) switching topology enjoys all these characteristics, making it the regulator of choice to drive LEDs whenever possible.

Constant-Current Power Stage

Switching regulators are most commonly known as voltage regulators. **Figure 4A** illustrates a basic constant-voltage buck regulator. The buck controller maintains a constant output voltage as the line voltage changes by varying the operating duty cycle (D) or the switching frequency. The desired output voltage set point is programmed using the following equation:

$$V_O = V_{FB} \frac{R_{FB1} + R_{FB2}}{R_{FB1}} \quad \text{Eq1}$$

The inductor, L, is selected to set the peak-to-peak current ripple, ΔI_{pp} , while the capacitor, Co, is selected to program a desired output-voltage ripple and to provide output-voltage hold-up under load transients. The average inductor current in a buck converter is equal to the load current, and, therefore, the load current can be programmed by controlling the peak-to-peak inductor-current ripple. This significantly simplifies the conversion of a constant-voltage source into a constant-current source. **Figure 4B** illustrates a basic constant-current buck regulator. Similarly, constant-current

buck regulators provide line regulation by adjusting the conversion duty cycle or the switching frequency, and the LED current, I_F , is programmed using the following equation:

$$I_F = \frac{V_{FB}}{R_{FB}} \quad \text{Eq2}$$

Setting the LED current, I_F , requires the proper sensing of the inductor current. Theoretically, multiple current sense schemes such as MOSFET $R_{ds(on)}$ sensing and inductor DCR sensing can be used. However, practically, the current sense precision of some of these would not meet the required LED current set point accuracy (5% to 15% for High Brightness LED). Directly sensing I_F through an inline resistor, R_{FB} , yields the needed precision, but may lead to excessive power dissipation in the current sense resistor. Lowering the feedback voltage, V_{FB} , allows the use of lower resistance value for the same I_F (**Eq2**), which minimizes losses. Newly-released dedicated LED drivers generally offer reference voltages (feedback voltages) within the range of 50 mV to 200 mV.

Uniquely, constant-current buck-driven regulators can be configured without output capacitance. The use of the output capacitor, Co, in these regulators is limited to AC current filtering since they inherently do not experience load transients and have continuous output currents. Configuring a constant-current buck regulator without output capacitance substantially increases the converter's output impedance and, in turn, boosts the converter's ability to rapidly change its output voltage so that it can maintain a constant current. As a result, the dimming speed and dimming range of the converter improve significantly. Wide dimming range is a highly demanded feature in applications such as backlighting and machine visions. On the other hand, lacking the output capacitance AC-current-ripple filtering necessitates the use of higher inductance values in order to meet the LED manufactures recommended ripple current ($\Delta I_F = \pm 5\%$ to $\pm 20\%$ of the DC forward current). At the same current rating, higher inductance values would increase the size and cost of the LED driver. Consequently, the use of output capacitors in constant-current buck-based LED drivers is governed by a tradeoff between cost and size on one hand, versus dimming speed and dimming range on the other hand. For example, to drive a single white LED ($V_F \approx 3.5V$) at 1A with a ripple current, ΔI_F , of $\pm 5\%$ from an input of 12V at 500 kHz would require a 50 μH inductor with a current rating of 1.1A. However if the inductor ripple-current is allowed to increase to $\pm 30\%$ then the inductance required is less than 10 μH . For the same core material and at approximately the same current rating, a 10 μH inductor will be typically offered at roughly half the size and the cost of a 50 μH inductor. To attain the desired ΔI_F ($\pm 5\%$) using the 10 μH inductor, the output capacitance

Designer's Corner

required is calculated based on the dynamic resistance, r_D , of the LED, the sense resistance, R_{FB} , and the impedance of the capacitor at the switching frequency, using the following expressions:

$$C_o = \frac{I}{2 \pi f_{sw} (Z_c - ESR)} \quad \text{Eq3}$$

Where:

$$Z_c = \frac{\Delta I_F}{\Delta I_L - \Delta I_F} (R_{FB} + r_D) \quad \text{Eq4}$$

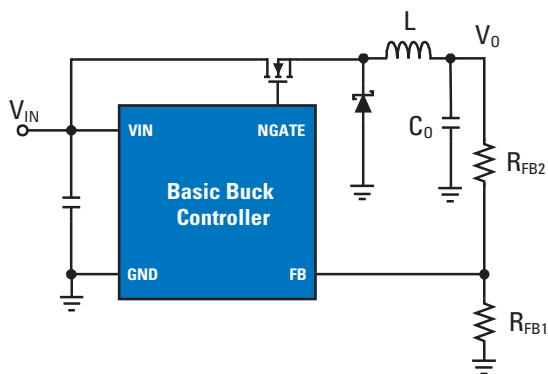

Figure 4A: Basic Step-Down (Buck) Voltage Regulator Figure

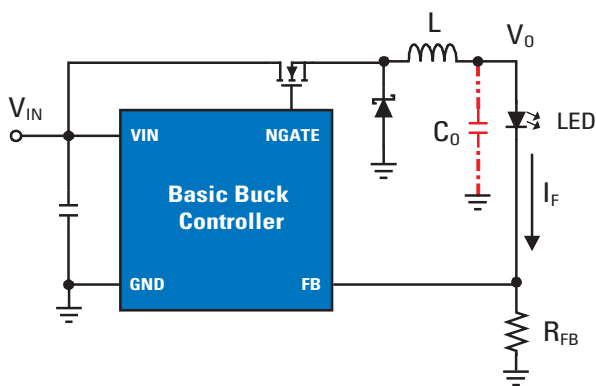

Figure 4B: Basic Step-Down (Buck) Current Regulator

Control-Loop schemes

Buck-based power stages are well-matched to several control-loop schemes and free of stability limitations such as right-half-plane zeros. They uniquely facilitate the shunt PWM dimming approach in addition to being compatible with other dimming methods. This provides the system designer with configuration flexibility when designing an LED driver for specific requirements. Hysteretic control is well-suited for applications such as light bulbs and traffic lights, in which variable switching frequencies are tolerated or where narrow input voltage range supplies are used. Hysteretic control does not experience control-loop bandwidth restrictions, which eliminates the need for loop compensation because of its inherent stability. Utilizing hysteretic control to drive a buck-based LED driver (**Fig 5A**) greatly simplifies the design as well as reduces the component count, and the cost of the driver. This configuration also yields superior PWM dimming ranges that outperform other buck-based schemes. Using hysteretic buck-based LED drivers with the shunt-dimming approach is well-suited for applications that require ultra-wide dimming ranges at high dimming frequencies and that can tolerate variable switching frequencies. Quasi-hysteretic buck-based LED drivers offer a good compromise between fixed-frequency operation and hysteretic control for applications in which variable switching frequencies may not be desired. The controlled on-time (quasi-hysteretic) buck-based LED driver (**Fig. 5B**) employs a control scheme based on a hysteretic comparator and a one-shot on-timer which is used to set a controlled on-time. This controlled on-time is programmed so that it is inversely proportional to the input voltage, and, therefore, it minimizes the switching frequency variations as the line voltage changes. Using this scheme also eliminates the need for control-loop bandwidth limitations, enabling it to achieve wide dimming ranges when used with different dimming configurations. In some cases, as in a number of automotive applications, synchronizing the LED driver(s) to an external clock or to each other may be required to minimize noise interference. Implementing the frequency synchronization feature with the non-clock-based hysteretic and quasi-hysteretic scheme can be challenging. In contrast, this feature can be simply realized in clock-based regulators such as the fixed-frequency buck LED driver shown in **Fig. 5C**. Fixed frequency control generally yields a more complex solution, and it limits the dimming range of the driver regardless of the dimming approach due to its dynamic response limitations.

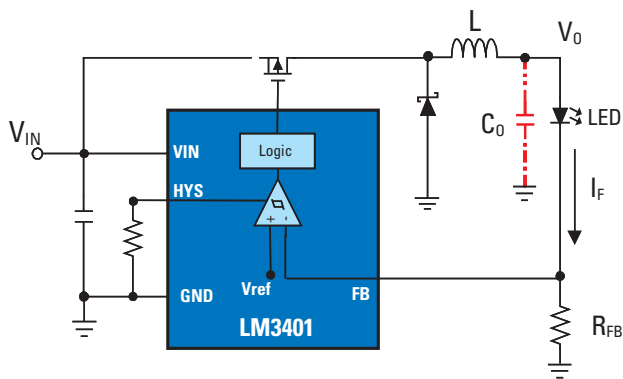

Figure 5A: Basic Hysteretic Buck-Based LED Driver

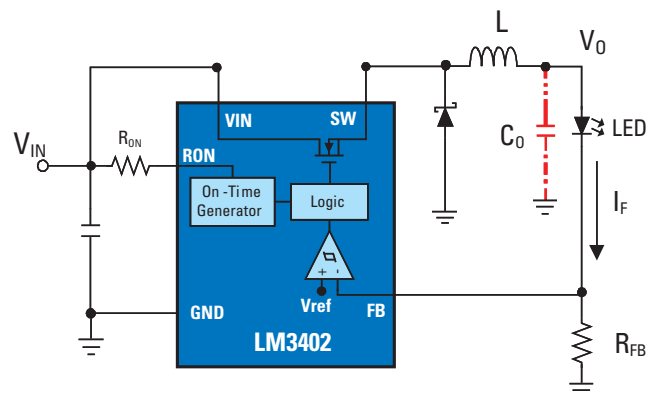

Figure 5B: Basic Controlled On-Time Buck-Based LED Driver

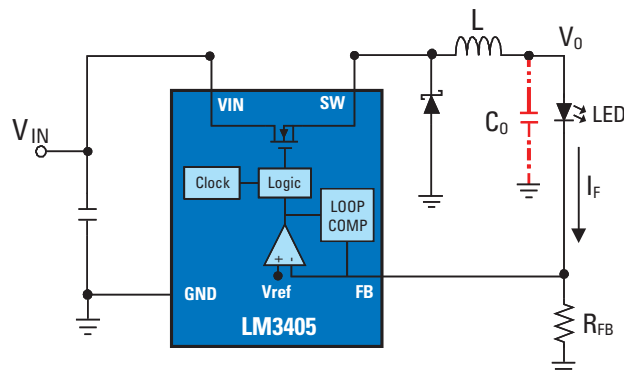

Figure 5C: Basic Fixed-Frequency Buck-Based LED Driver

Conclusion

There are many characteristics which make buck-based regulators attractive LED drivers. They are simple to configure as a current source and can be realized with minimum component counts, which simplifies the design process, improves the drivers' reliability, and reduces cost. Buck-based LED drivers also provide configuration flexibility since they are compatible with multiple control schemes. They also allow for high-speed dimming as well as wide dimming ranges since they can be configured without output capacitance and are well-matched to various dimming approaches including shunt dimming. All these features make buck-based (step-down) LED drivers the topology of choice whenever the

application permits. Now, the question is: what if the application does not permit? Applications such as residential and commercial lighting require thousands of lumens, creating a need to drive LED strings. The total forward voltage drop of an LED string is equal to the sum of the forward voltage drops of all the LEDs in the string. In some cases, the input voltage range of the system can be lower than the forward voltage drop of the LED string, or it can vary so that sometimes it's lower and sometimes it's higher. These scenarios would require either boost, or buck-boost switching regulators. The next article will discuss, in detail, the challenges of using boost and buck-boost topologies to drive LEDs as well as LED dimming with these schemes.

Designer's Corner

Light Matters Part 2: Boosting, Buck-Boosting and Dimming

— By Sameh Sarhan & Chris Richardson, Applications Engineer

Introduction

Although the buck is preferred, the boost regulator is finding more use as a direct drive for LEDs as the number of LEDs used in LED lighting applications increases. Designers are targeting large-scale general illumination and systems that require thousands of lumens. Examples include street lighting, residential and commercial lighting, stadium lighting, and decorative or architectural lighting of spaces both interior and exterior.

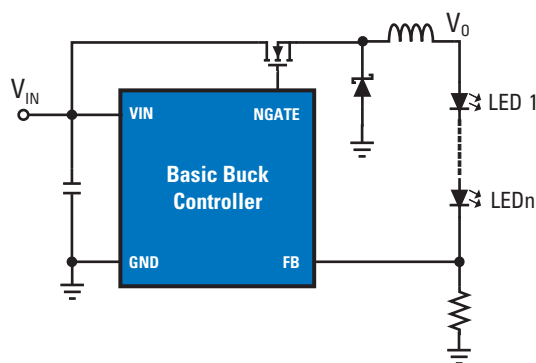

$$V_0 = n \times V_F$$

$$V_0 < V_{IN}$$

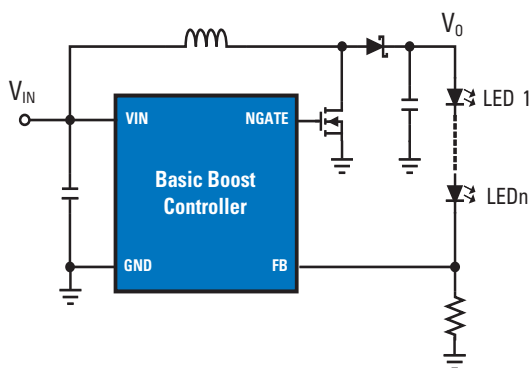

$$V_0 = n \times V_F$$

$$V_0 > V_{IN}$$

Figure 1: Buck and Boost LED Drivers with V_0 Calculation

Ideally every LED in every light source would be placed in a single series chain, ensuring that the same current flows through each device. Even though most general lighting is powered from AC line voltage, in many cases an intermediate DC bus voltage is used,

derived from an AC-DC regulator that takes a universal AC input and provides PFC, isolation, and filtering. Safety standards and electrical codes such as U.L. and C.E. limit the output voltage of the AC-DC power supply that forms the input to an LED driver. Common rails are 12V and 24V, and in some cases 48V. Rarely are these intermediate bus rails higher than 60V, which is the cutoff for DC voltages under U.L. Class 2.

The Challenge of Boost

Boost regulators are more difficult to design and control than buck regulators, regardless of whether the output voltage or the output current is being controlled. Boost regulators require design review at the limits of input voltage to ensure correct design of the inductor, especially the peak current rating. A boost LED driver adds a variable output voltage that influences duty cycle and therefore the inductance and current rating of the main inductor. To prevent inductor saturation, the maximum average and peak currents must be evaluated at both V_{IN-MIN} and V_{O-MAX} . The more LEDs are placed in series, the greater the gap between V_{O-MIN} and V_{O-MAX} .

Unlike the buck regulator with its output inductor, the boost converter has a discontinuous output current. An output capacitor is required to keep the output voltage and output current continuous. In a current regulator the output capacitor functions purely as an AC current filter, and capacitance is made as low as possible while still maintaining the desired LED ripple current.

Another serious challenge for boost converters is the control loop. Most boost converters use peak current mode control, where the impedance of the load has a strong effect on both the DC gain and the low-frequency system pole. For voltage regulators the load impedance is determined by dividing output voltage by output current. LEDs are diodes, with a dynamic resistance. This dynamic resistance can only be determined by plotting the V_F vs. I_F curve and then taking the tangent line to find the slope at the desired forward current. As shown in **Figure 1**, the current regulator uses the load itself as a feedback divider to close the control loop. This reduces the DC gain by a factor of $(R_{SNS} / (R_{SNS} + r_D))$. It is tempting to compensate a boost LED driver with a simple integrator, sacrificing bandwidth for stability. The reality is that many, if not most LED driver applications requiring dimming. Whether dimming is done by linear adjustment of I_F (Analog Dimming) or by turning the output on and off at high frequency (Digital, or PWM Dimming) the system requires high bandwidth and fast transient response just a voltage regulator does.

Further Challenge: Buck-Boost

LEDs for lighting are being adopted much faster than the standards for solid state illumination have developed, and one result is that the input voltages for LED lighting systems often overlap the output voltage (remember, $V_o = n \times V_f$). Every buck-boost topology stores the entire energy delivered to the load during each cycle in an inductor, transformer or a capacitor, which results in higher peak currents, higher peak voltages or both in the power switches. In particular, evaluation of the converter at the corners of both input voltage and output voltage is necessary because peak switch current occurs at V_{IN-MIN} and V_{O-MAX} , but peak switch voltage occurs at V_{IN-MAX} and V_{O-MAX} .

The single inductor buck-boost can be built with the same parts count as a buck regulator or boost regulator, making it attractive from a system cost standpoint. One disadvantage of this topology is that the polarity of V_o is inverted (**Figure 2a**) or regulated with respect to V_{IN} (**Figure 2b**). Level-shifting or polarity inverting circuitry must be employed. Like the boost converter, they have a discontinuous output current, and require an output capacitor to maintain a continuous LED current. The power MOSFET suffers a peak current of I_{IN} plus I_F and a peak voltage of V_{IN} plus V_o .

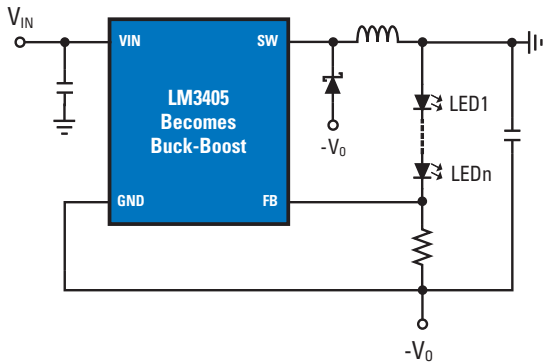

Figure 2a: High-side Buck-Boost

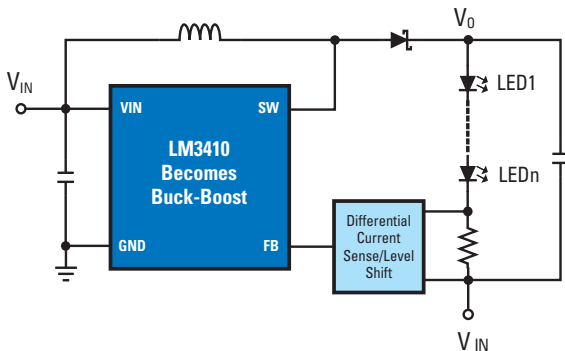

Figure 2b: Low-side Buck-Boost

The SEPIC converter and Cuk converters both use low-side regulators and have the advantage of a continuous input current due to the input inductor. Their disadvantage lies in needing two inductors, (they can be coupled inductors) and an additional capacitor. The SEPIC requires an output capacitor to maintain a smooth LED current but has a positive V_o , where the Cuk can eliminate the output capacitor but has a negative V_o .

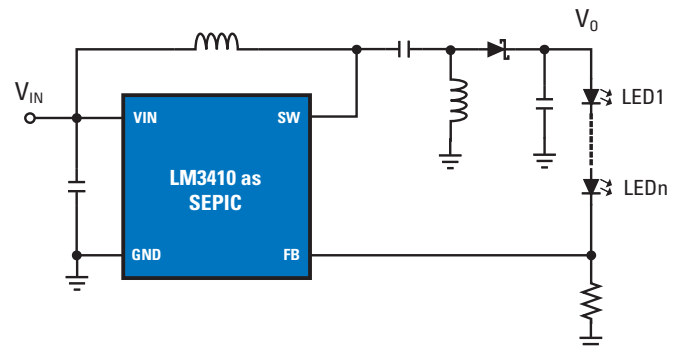

Figure 3: SEPIC LED Driver

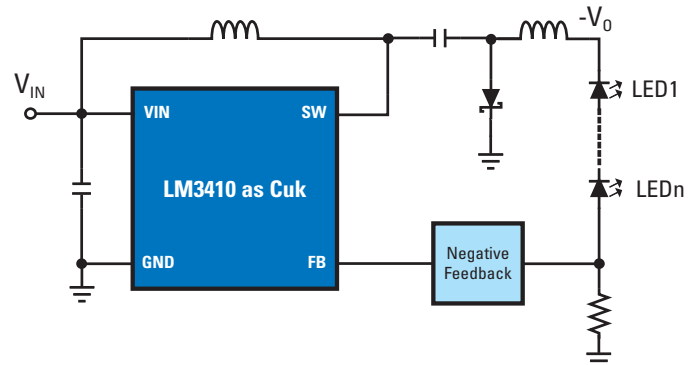

Figure 4: Cuk Regulator

Control LED Light: Dimming

Two main choices for LED light control exist: adjust the LED current linearly (analog dimming) or turning the current on and off at a frequency high enough for the eye to average the light output (digital dimming). Using PWM to set the period and duty cycle is the traditional way to accomplish digital dimming.

Designer's Corner

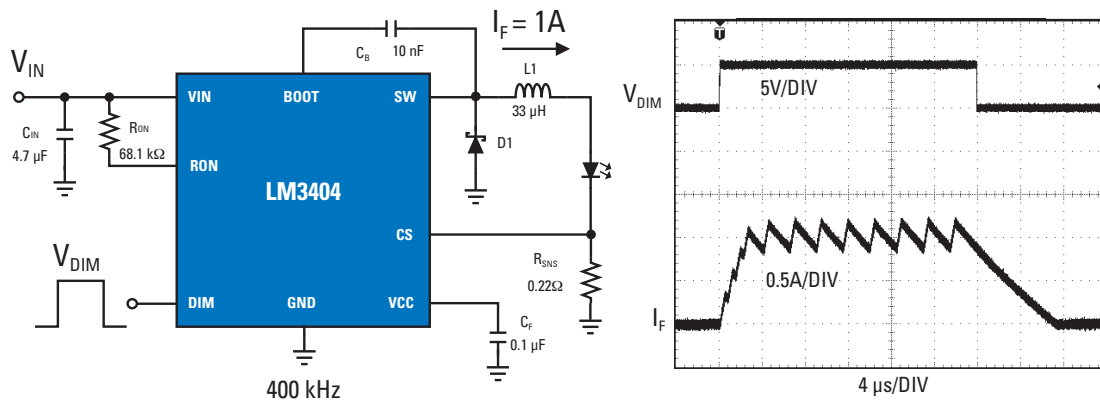

Figure 5: LED Driver Using PWM Dimming with Waveforms

PWM Dimming Preferred

Analog dimming is often simpler to implement, however PWM dimming is used in many designs due to a fundamental property of LEDs: correlated color temperature (white LEDs) or dominant wavelength shifts in proportion to the average drive current. To make white LEDs a blue LED is coated with a broad range phosphor. At low current the light looks more yellow (warm white) but at high current the blue emission dominates and the light becomes more bluish, or cool white. LED manufacturers specify a certain drive current in the electrical characteristics tables of their products where they guarantee the dominant wavelength or CCT. Dimming with PWM ensures that the LEDs emit the color that the lighting designer needs regardless of the intensity.

Analog dimming also presents a challenge to the output current accuracy. Almost every LED driver uses a resistor in series with the output to sense current. The current sense voltage, V_{SNS} , is selected as a compromise between low power dissipation and high signal-to-noise ratio, SNR. To reduce output current in a closed-loop system, V_{SNS} must be lowered, reducing the output current accuracy in proportion.

Dimming Frequency vs. Contrast Ratio

Every LED driver has a finite response time when responding to a PWM dimming signal. Three types of delay are shown in **Figure 6**, and the longer these delays are the lower the achievable contrast ratio (a measure of control over lighting intensity).

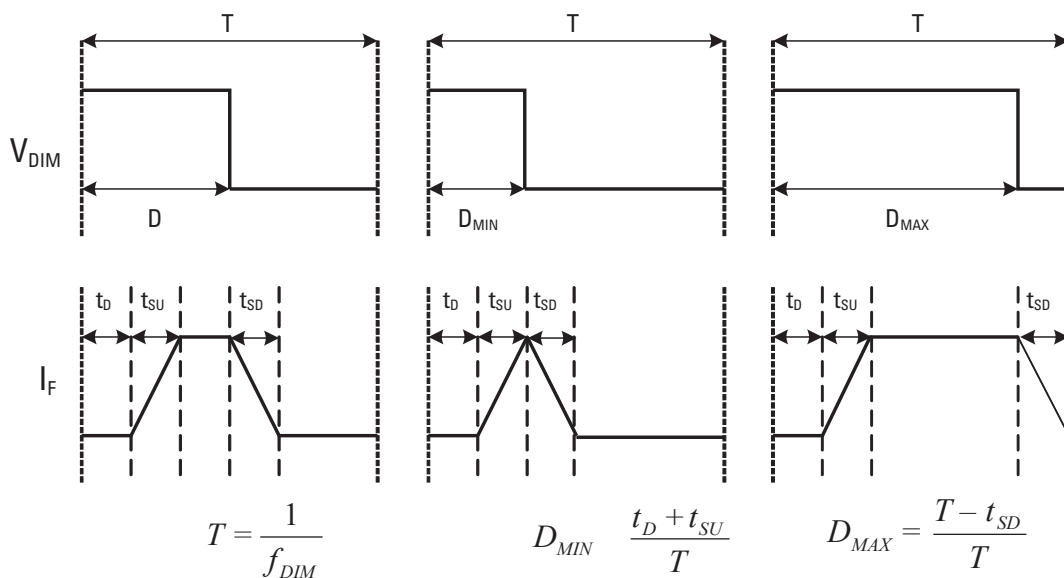

Figure 6: Dimming Delays

In **Figure 6**, the quantity t_D represents the propagation delay from when V_{DIM} goes high to when LED current begins to rise. The quantity t_{SU} represents the LED current slew up time, and the quantity t_{SD} represents the slew down time. In general, the lower the dimming frequency, f_{DIM} , the higher contrast ratio, as these fixed delays consume a smaller portion of the dimming period, T_{DIM} . The lower limit for f_{DIM} is approximately 120 Hz, below which the eye no longer blends the pulses into a perceived continuous light. The upper limit is determined by the minimum contrast ratio that is required. Contrast ratio is typically expressed as the inverse of the minimum on-time:

$$CR = I / t_{ON-MIN} : I$$

$$t_{ON-MIN} = t_D + t_{SU}$$

Dimming with a Switching Regulator

Switching regulators designed for standard power supplies often have an enable or shutdown pin to which a logic-level PWM signal can be applied, but the associated delays are often quite long. This is because the silicon design emphasizes low shutdown current over response time. Dedicated switching regulations for driving LEDs will do the opposite, keeping their internal control circuits active while the enable pin is logic low to minimize delay.

Optimizing light control with PWM requires minimum slew-up and slew-down delays not only for best contrast ratio, but to minimize the time that the LED spends between 0 and the target level. Where a standard switching regulator will have a soft-start and often a soft-shutdown, dedicated LED drivers do everything within their control to reduce these slew rates. Reducing t_{SU} and t_{SD} involves both the silicon design and the topology of switching regulator that is used.

Buck regulators are superior to all other switching topologies with respect to fast slew rates, for two distinct reasons. First, the buck regulator is the only switching converter that delivers power to the

output while the control switch is on. This makes the control loops of buck regulators with voltage-mode or current-mode PWM (not to be confused with the dimming via PWM) faster than the boost regulator or the various buck-boost topologies. Power delivery during the control switch on-time also adapts easily to hysteretic control, which is even faster than the best voltage-mode or current-mode control loops. Second, the buck regulator's inductor is connected to the output during the entire switching cycle. This ensures a continuous output current and means that the output capacitor can be eliminated. Without an output capacitor the buck regulator becomes a true, high impedance current source, capable of slewing the output voltage very quickly. Cuk and zeta converters can claim continuous output inductors, but fall behind when their slower control loops (and lower efficiency) are factored in.

Faster than the Enable Pin

Some applications need high PWM dimming frequency and high contrast ratio, which requires faster slew rates and shorter delay times than even a hysteretic buck without output capacitance can provide. The PWM dimming frequency must often be pushed to beyond the audio band, to 25 kHz or more. Total rise and fall times for the LED current, including propagations delays, must be reduced to the nanosecond range.

Starting with a fast buck regulator with no output capacitor, the delays in turning the output current on and off come from the IC's propagation delay and the physical properties of the output inductor. The best way to bypass both is by using a power switch in parallel to the LED chain, shown in **Figure 7**. To turn the LEDs off, the drive current is shunted through the switch, which is typically an N-MOSFET. The IC continues to operate and the inductor current continues to flow. Some power is wasted while the LEDs are off, but the output voltage drops to equal the current sense voltage during this time.

Dimming with a shunt FET causes rapid shifts in the output voltage,

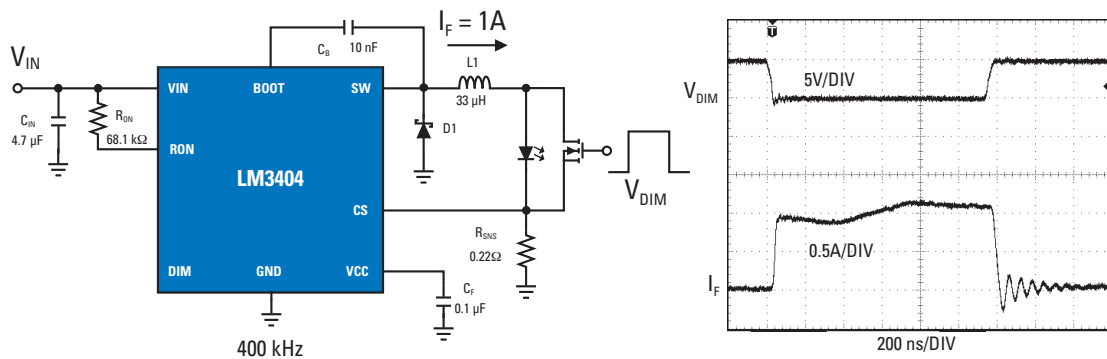

Figure 7: Shunt FET Circuit with Waveforms

Designer's Corner

to which the IC's control loop must respond in an attempt to keep the output current constant. As with logic-pin dimming, the faster the control loop, the better the response, and again buck regulators with hysteretic control provide the best response.

Fast PWM with Boost and Buck-Boost

Neither the boost regulator nor any of the buck-boost topologies are well suited to PWM dimming. Their slower control loops and mandatory output capacitors (except for C_{uk}) make logic pin dimming much slower than bucks. Trying to dim the output of a boost with

parallel FETs will cause an input short circuit, and will cause runaway input inductor current in SEPIC or C_{uk} . A two-stage system that uses boost and then a buck regulator as the second, LED driving stage is one possibility. When space and cost do not permit this approach, the next best choice is a series switch, shown in **Figure 8**. Series FET dimming is difficult to achieve without a dedicated LED driver IC because interruption of the LED current also disconnects the feedback to the control loop, which causes the output voltage to rise uncontrollably.

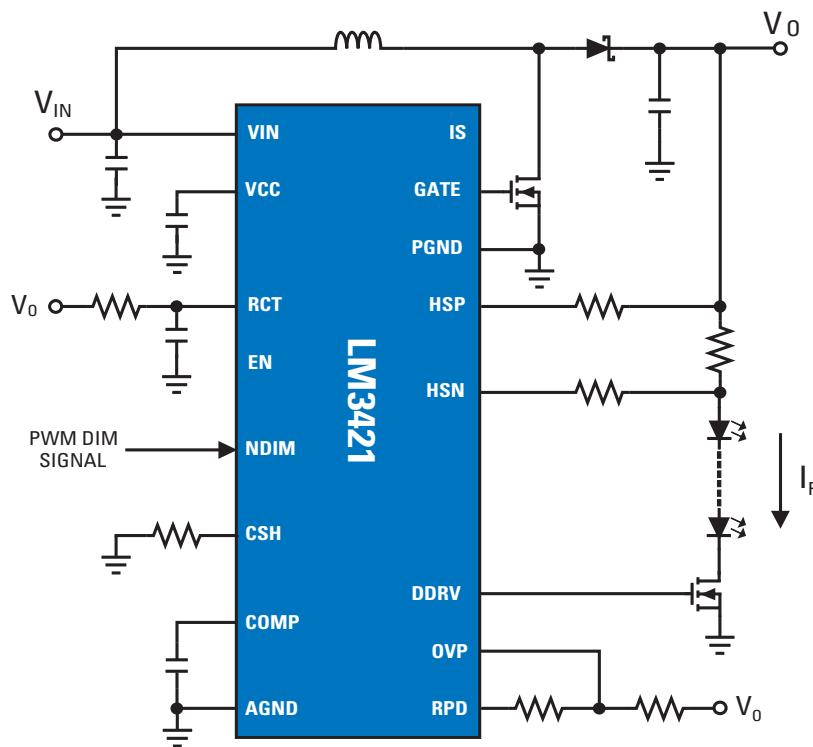

Figure 8: Boost Regulator with Series DIM Switch

EMI Design for LED Streetlamp Application

The LM3402HV circuitry shown in **Figure 1** is based on a street lamp application. The input is 48 VDC, output is 12 pcs of 1W LEDs in series. To address the EMI concerns, the schematic and PCB layout were modified. As a result of the modifications, as shown in **Figure 2** below, better EMI performance was achieved and the EN55022 standard was passed. The modifications are:

- 1: One resistor R_z (50 Ω) is added between the SW pin and Cb pin. This changes the SW node waveform from **Figure 3** to **Figure 4**. The criterion of R_z selection is dependent on the SW turn-on slew rate and its ringing. The smaller the ringing, the better.
- 2: 1 μF output cap is added across LED connection port.
- 3: Input loop area should be kept as small as possible, which is shown in dash-red area of **Figure 5**. C_{in} should be connected with anode of catch diode directly.
- 4: The SW node should be kept as short as possible.

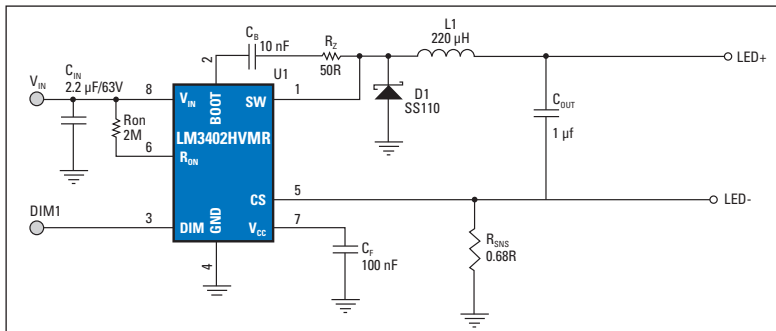

Figure 1

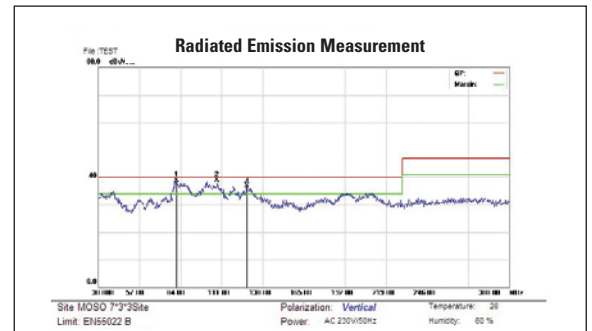

Figure 2

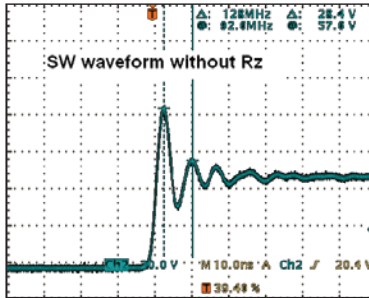

Figure 3

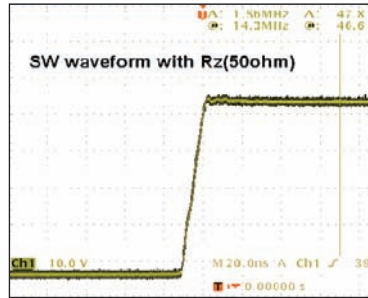

Figure 4

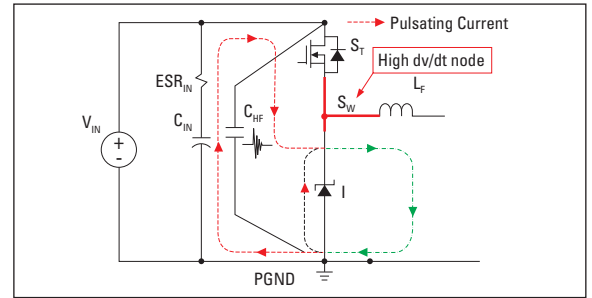

Figure 5

Designer's Corner

Two-Wire Dimming

LM3406 Two-Wire Dimming

Adding an external input diode and using the internal V_{INS} comparator allows the LM3406/06HV to sense and to provide PWM dimming of LED by chopping of the input voltage. This method is also referred to as "Two-Wire Dimming", and a typical application circuit is shown below.

If the V_{INS} pin voltage falls 70% below the V_{IN} pin voltage, the LM3406/06HV disables the internal power FET and shuts off the current to the LED array. The support circuitry (driver, bandgap, V_{CC}) remains active in order to minimize the time needed to the turn the LED back on when the V_{INS} pin voltage rises and exceeds 70% of V_{IN} . This minimizes the response time for turning the LED array back on.

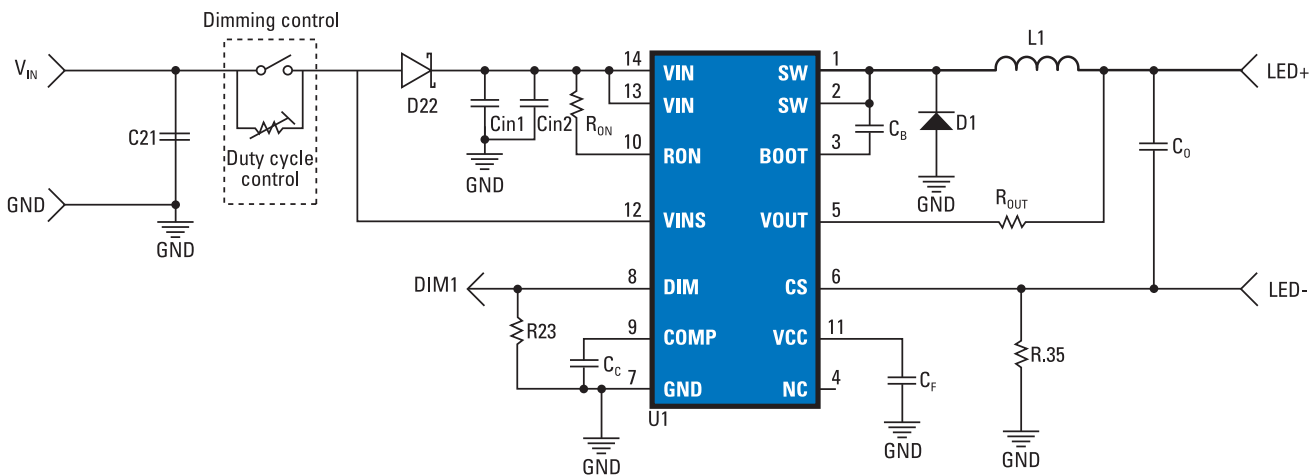

The benefit of two-wire dimming:

One wire less than traditional PWM dimming, further reducing the wiring cost.

Design Tools and Packaging

WEBENCH® LED Designer Fully Supports LED Partners

Create Your Next Lighting Design in Minutes

The WEBENCH LED Designer Tool Recommends the Optimal LED for Your Specifications and Delivers a Complete Power Supply Design in Minutes



1. Choose an LED at national.com/led

Enter your requirements and receive a list of LEDs from the leading manufacturers

2. Design Your Power Supply

Select a PowerWise® LED driver from the optimized short list provided

3. Complete and Verify Your Design

Optimize between efficiency and size

4. Order a Customized Prototype Kit

What's More

National's LED reference design library provides specifications, schematic diagrams, BOMs, layout guidelines, and application downloads to help you implement and jump-start your design. Visit www.national.com/webench/ledrefdesigns.do

Packaging Solutions



Leadless Leadframe Package (LLP®)

National's LLP® package provides excellent power dissipation capability in a very small footprint.

AVAILABLE
LEAD-FREE



TSOP6
 θ_{JA} 118°C/W



LLP-6
 θ_{JA} 80°C/W



MSOP-8
 θ_{JA} 151°C/W



PSOP8
 θ_{JA} 50°C/W



SO-8
 θ_{JA} 118°C/W



MSOP-10
 θ_{JA} 121°C/W



eMSOP-10
 θ_{JA} 100°C/W



TSSOP14
 θ_{JA} 50°C/W



TSSOP16 EP
 θ_{JA} 37.4°C/W



TSSOP20 EP
 θ_{JA} 34°C/W



LLP-24
 θ_{JA} 39°C/W



TSSOP28
 θ_{JA} 32°C/W

Worldwide Design Centers and Manufacturing Facilities



- Design Centers
- Manufacturing Facilities

Design Centers

USA:

Arlington, Texas
 Calabasas, California
 Chandler, Arizona
 Federal Way, Washington
 Fort Collins, Colorado
 Grass Valley, California
 Indianapolis, Indiana
 Longmont, Colorado
 Norcross, Georgia
 Phoenix, Arizona
 Rochester, New York
 Salem, New Hampshire
 San Diego, California
 Santa Clara, California
 South Portland, Maine
 Tucson, Arizona

EUROPE:

Delft, Netherlands
 Unterhaching, Germany
 Greenock, Scotland
 Milan, Italy
 Oulu, Finland
 Tallinn, Estonia

ASIA:

Bangalore, India
 Hangzhou, China
 (joint with Zhejiang University)
 Hong Kong, China
 Tokyo, Japan

Manufacturing Facilities

Wafer (Die) Fabrication:

Arlington, Texas USA
 South Portland, Maine USA
 Greenock, Scotland

Chip Test and Assembly:

Melaka, Malaysia
 Suzhou, China

World Headquarters

2900 Semiconductor Drive
 Santa Clara, CA 95051
 USA
 +1 408 721 5000
www.national.com

Mailing Address:

PO Box 58090
 Santa Clara, CA 95052
support@nsc.com

European Headquarters

Livry-Gargan-Str. 10
 82256 Fürstfeldbruck
 Germany
 +49 8141 35 0
national.com/support
europe.support@nsc.com

Asia Pacific Headquarters

2501 Miramar Tower
 1 Kimberley Road
 Tsimshatsui, Kowloon
 Hong Kong
 +852 2737 1800
ap.support@nsc.com

Japan Headquarters

Beside KIBA
 2-17-16
 Kiba, Koto-ku
 Tokyo, 135-0042, Japan
 +81 3 5639 7300
jpn.feedback@nsc.com

