

1A WHITE LED DRIVER WITH PWM DIMMING CONTROLLER

DESCRIPTION

The SD42511 is a step-down PWM control LED driver with a built-in internal power MOSFET. It achieves 1A continuous output current over a wide input supply range. It provides thermal shutdown circuit, current limiting circuit and PWM dimming circuit.

SD42511 adopts current mode control. Current mode operation provides fast transient response and simple loop stabilization design. SD42511 has high efficiency up to more than 90%, and has excellent constant current characteristic when the input/output voltage changed, with the excellent current accuracy within $\pm 1\%$. With the high input voltage of up to 25V and built-in slope compensation, it can drive 6 LEDs.

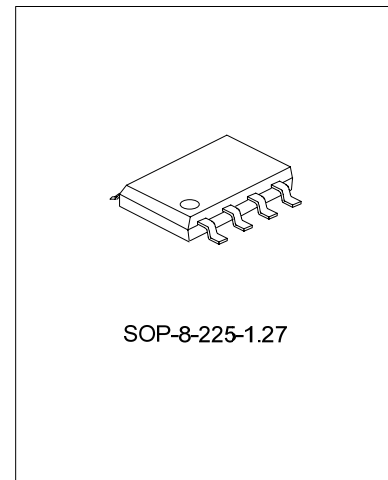

FEATURES

- * Maximum 1A output current
- * 0.25 Ω built-in power MOSFET
- * PWM dimming function
- * 280KHz fixed frequency
- * Excellent constant current accuracy $\pm 1\%$
- * High efficiency up to 90%
- * Thermal shutdown
- * Cycle-by-cycle over current protection
- * 6-25V input voltage range
- * Drive LED string

ORDERING INFORMATION

Device	Package
SD42511	SOP-8-225-1.27

APPLICATIONS

- * Power LED driver

BLOCK DIAGRAM

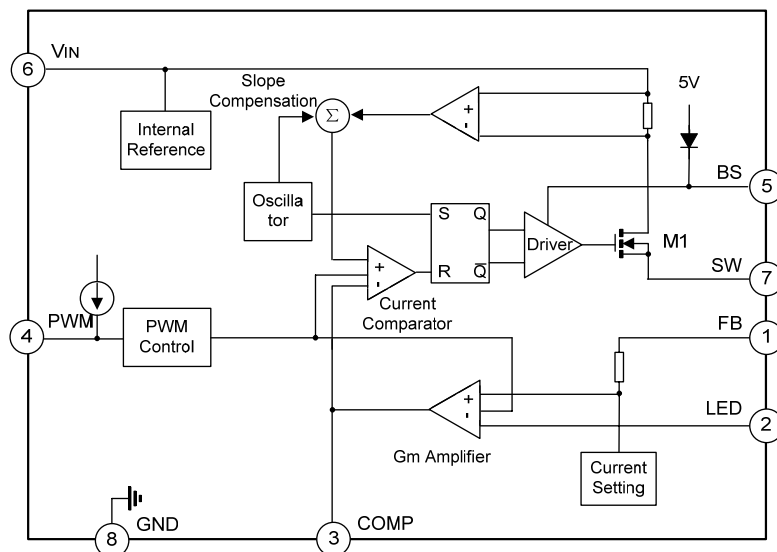

ABSOLUTE MAXIMUM RATING

Characteristics	Symbol	Ratings	Unit
Supply Voltage	VIN	28	V
Switch Voltage	VSW	-1~VIN+1	V
Boost Voltage	VBS	VSW+6	V
Feedback Voltage	VFB	-0.3~VIN	V
PWM Voltage	VPWM	-0.3~6	V
Comp Voltage	VCOMP	-0.3~6	V
LED Voltage	VLED	-0.3~VIN	V
Junction Temperature	Tj	150	°C
Lead Temperature	TL	260	°C
Storage Temperature	TSTG	-65~150	°C
Input Voltage	VIN	5~25	V
Operating Temperature	TOPR	-40~125	°C

ELECTRICAL CHARACTERISTICS (Unless otherwise specified, VIN=12V, Tamb=25°C)

Characteristics	Symbol	Test Condition	Min.	Typ.	Max.	Unit
Operating Current	IIN	VFB≥3.5V		2.0	2.3	mA
Upper Switch Leakage	IL	VSW=0V		0	10	μA
Current Limit	ILIM		1.3	1.6	2.0	A
Maximum Duty Cycle	Dmax	VFB=0V	--	93	--	%
Oscillator Frequency	fosc		250	280	310	kHz
PWM Dimming Threshold Voltage	VPWMTH		1.2	1.5	1.8	V
PWM pull-down current	IPWM1	VPWM=5V		50	60	μA
PWM pull-up current	IPWM1	VPWM=0V		60	70	μA
COMP Clamp Voltage	VCOMP	Open without load	1.9	2.2	2.5	V
Switch Transistor on Resistance	RONH		--	0.25	--	Ω

PIN CONFIGURATION

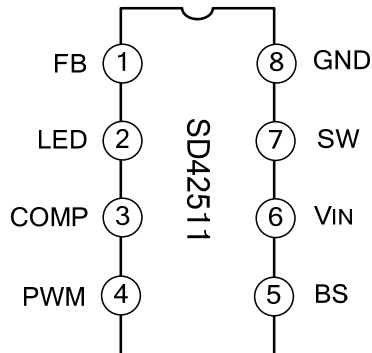

PIN DESCRIPTION

Pin No.	Pin Name	I/O	Description
1	FB	I	Current sense pin ,connect inductance and sense resistor.
2	LED	O	LED positive connecting end, the other end connects to the sense resistor.
3	COMP	I/O	Compensation pin, connects to external capacitor
4	PWM	I	PWM dimming pin, connects PWM signal to change the output current.
5	BS	I	Bootstrap pin, used to increase the power MOSFET voltage
6	VIN	I	Input supply voltage.
7	SW	O	Power output.
8	GND	-	Ground.

FUNCTION DESCRIPTION

The SD42511 is a current mode LED driver. The voltage on compensation pin COMP is proportional to the current delivered to the load.

At the beginning of a cycle: the upper transistor M1 is off; the COMP pin voltage is higher than the current sense amplifier output; and the current comparator's output is low. The rising edge of the 280KHz CLK signal sets the RS Flip-Flop. Its output turns on M1 thus connecting the SW pin and inductor to the input supply. The inductor current is sensed and amplified by the current sense amplifier. Ramp compensation is summed to current sense amplifier output and compared to the Gm amplifier output by the current comparator. When the current sense amplifier plus ramp compensation signal exceeds the comp pin voltage, the RS Flip-Flop is reset and the chip reverts to its initial M1 off state. If the current sense amplifier plus slope compensation signal does not exceed the comp voltage, then the falling edge of the CLK resets the Flip-Flop.

The Gm amplifier compares the output current to the threshold current (threshold current is set by internal). When the output current is higher than threshold current, the COMP pin's voltage is lower down. Since the COMP pin's voltage is proportional to the peak inductor current a decrease in its voltage decreases current delivered to the output. When the output current is lower than threshold current, the COMP pin's voltage is up while the output current increases. The output current is stable at the set value by the adjusting of the loop.

1. PWM Dimming Function

SD42511 has internal PWM dimming function. When PWM voltage is open or connects to high level, the chip is working normally; when PWM voltage connects to low level, COMP pin disconnects with the chip, the charge of the capacitor is in hold state, voltage level holds, and the output of current comparator is high, transistor is off without output current. When PWM signal is high, COMP pin is connected with the chip to improve the startup speed of the chip. Adjust the output current by control the duty of external PWM signal.

The minimum setup time of SD42511 PWM dimming is less than 20 μ S, and the maximum PWM dimming ratio is up to 500:1. When high dimming ratio is needed, the dimming frequency is recommended 500Hz below; or else the dimming frequency can be up to 2 KHz. When PWM pin is low, output is shutdown. In normal station, LED pin holds above 2V, and if the LED or other components have electric leakage which makes the LED pin is low and caused change on PWM dimming, we recommend to increase the output capacitor, then the LED level will not be too low when shutdown to maintain the normal PWM dimming.

2. Output Current Setting

The output current is determined by the sampling resistor and setting voltage. The sampling voltage of VFB-VLED is divided into 86mV and 81mV, and adjust the output current by adjusting the sampling resistor Rs (refer to Typical Application Circuit).

$$I_{OUT} = \frac{V_{FB} - V_{LED}}{R_S}$$

3. Bootstrap Circuit

SD42511 has Bootstrap circuit, which provides grid drive voltage to power MOSFET; the chip has diode to charge the bootstrap capacitor by 5V standard voltage.

4. Current Limiting Function

SD42511 has internal current limiting function, and the voltage on COMP is clamped at about 2.2V, the output current of the power MOSFET is limited at about 1.6A by current comparator.

COMPONENTS SELECTION

1. Input Capacitor Selection

The input capacitor provides the pulse current when the power MOSFET is on, and charge the capacitor when the power MOSFET is off, thus to keep the stability of the input voltage. The input capacitor is recommended to be more than 10 μ F, which can reduce the peak current drawn from input source and the switch noise. The input capacitor should be near to the input pin when in real routing.

2. Output Capacitor Selection

Parallel connecting a capacitor between the two ends of LED can reduce the output voltage ripple accordingly reduce the ripple current of LED, while this capacitor will not effect the operating frequency and efficiency, but the start time will be longer by reducing the rising speed of the voltage on LED. The larger the output capacitor is, the smaller the current ripple on LED is. We recommend use the capacitor of 4.7 μ F.

3. Inductance Selection

The inductance is used to keep the output current constant, the bigger the inductance is, the smaller the output current ripple is; while the bigger the physical size is, the bigger the series-wound resistor is. The selected effective current (RMS current rating)of inductance current should be bigger than the maximum output current, and the saturation current should be 30% bigger than maximum output current. In order to improve the efficiency, the series-wound resistor (DCR) of inductance should be smaller than 0.2 Ω .

The relation between inductance and ripple:

$$L = V_{OUT} * \frac{V_{IN} - V_{OUT}}{V_{IN} * f * \Delta I}$$

Where: L: Inductance value

F: Oscillator frequency

ΔI is ripple current

When select inductance, you should consider the combination of various factors to select suitable inductance. When output current is 1A, 47 μ H inductance is recommended.

4. Diode Selection

SD42511 is a non-synchronous step-down adjuster, so the diode should provide continuous current when the power MOSFET is off. Because the forward voltage of Schottky diode is small, and the reverse continuous current time is short, so it is usually used for continuous current. During the power MOSFET is conducting, the diode will withstand high voltage, so the reverse voltage of selected diode should be bigger than the input voltage.

The average current through the diode is I_D :

$$I_D = (1-D) * I_{LED} \quad I_{LED} \text{ is the current of LED}$$

When the input voltage is high with a small duty, I_D increases, so the selected maximum continuous current diode should be bigger than the output current.

TYPICAL APPLICATION CIRCUIT

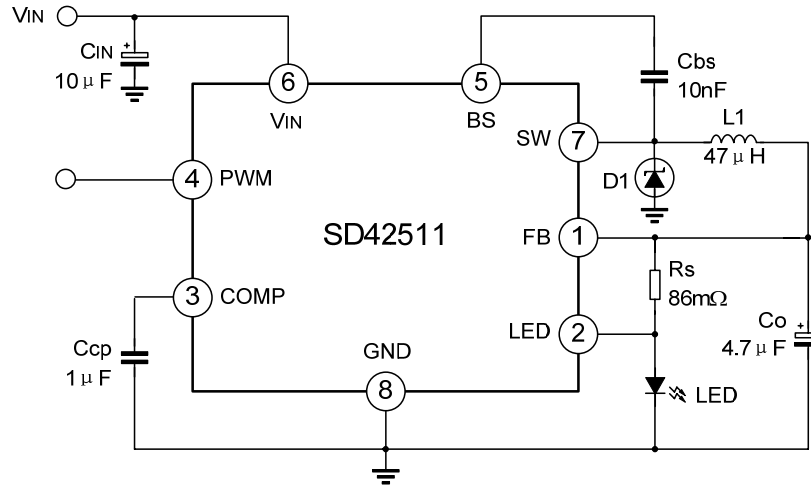

6~25V input voltage, 1A output LED driver

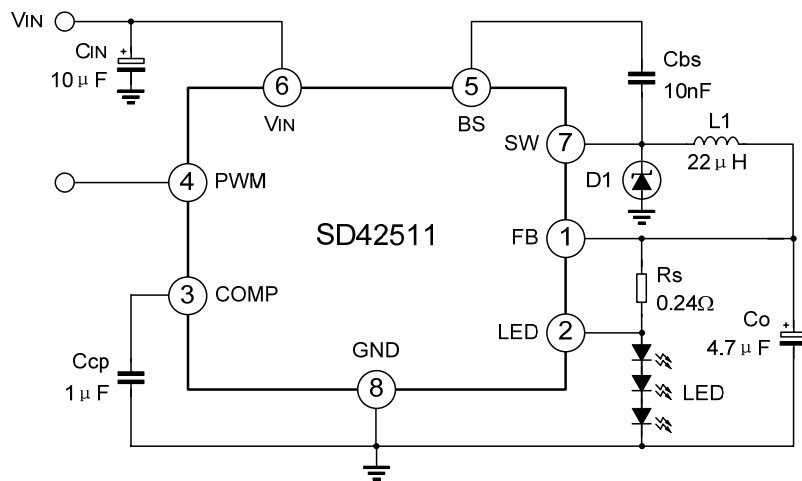

12V input voltage, 350mA output three strings of LED driver

Note: The circuit and parameters are reference only, please set the parameters of the real application circuit based on the real test .

ELECTRICAL CHARACTERISTICS CURVE

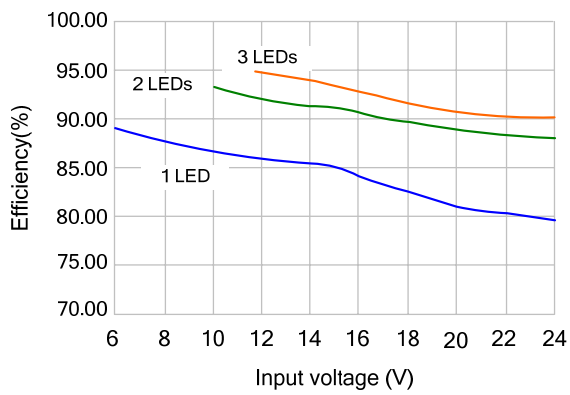

Output 350mA efficiency changed with input voltage

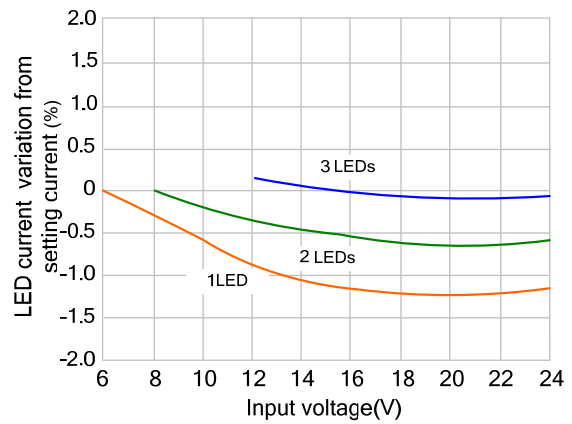

Output 350mA current changed with the rate of input voltage change

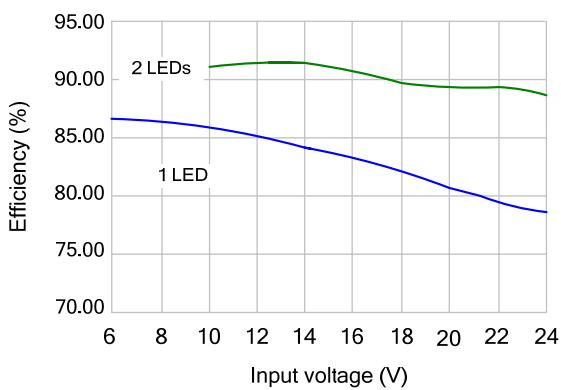

Output 700mA efficiency changed with input voltage

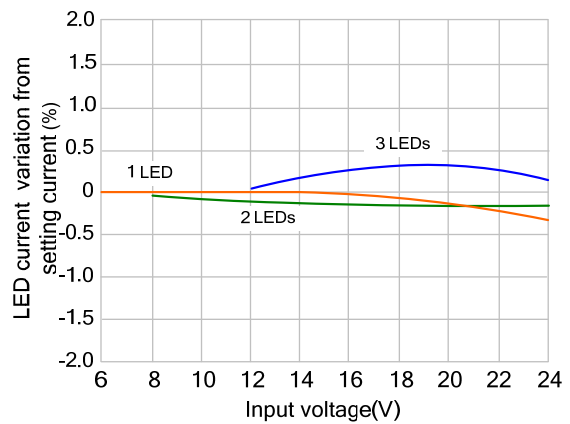

Output 700mA current changed with the rate of input voltage change

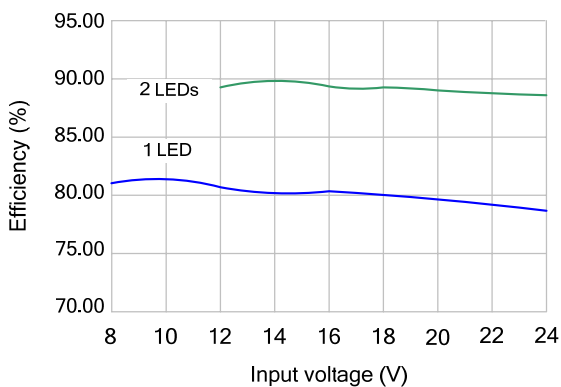

Output 1A efficiency changed with input voltage

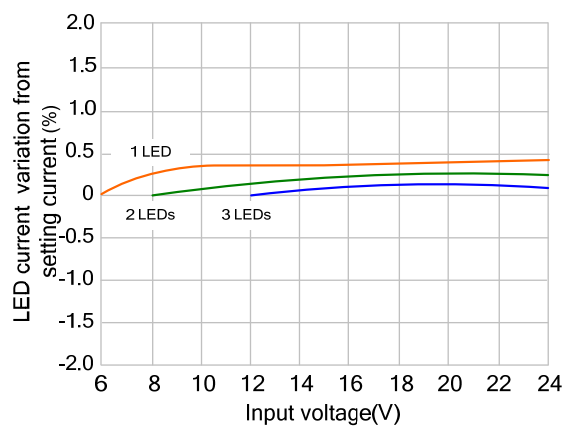

Output 1A current changed with the rate of voltage change

ELECTRICAL CHARACTERISTICS CURVE (continued)

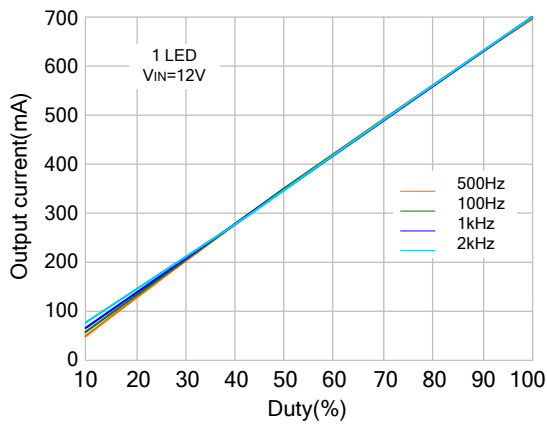

PWM dimming behavior of 1 LED(700mA)

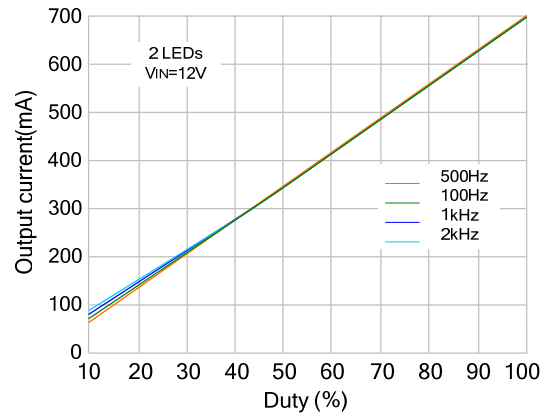

PWM dimming behavior of 2 LEDs(700mA)

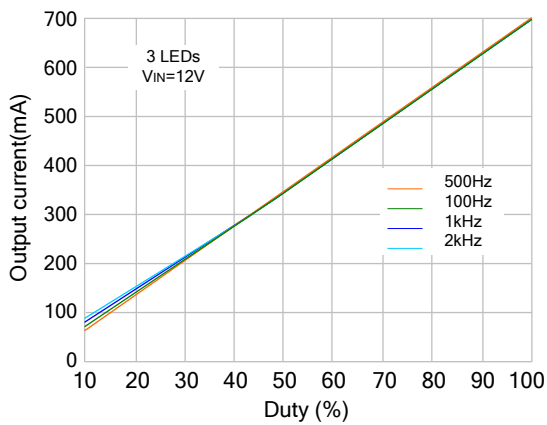

PWM dimming behavior of 3 LEDs(700mA)

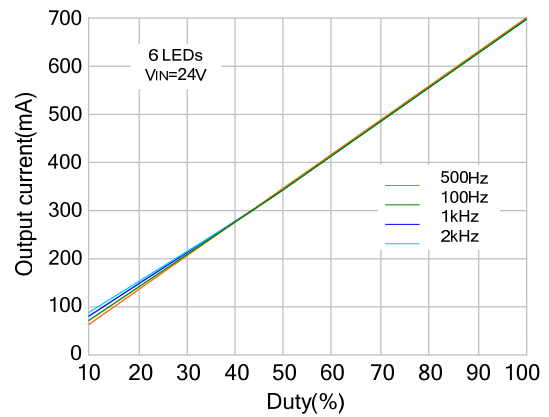

PWM dimming behavior of 6 LEDs(700mA)

PACKAGE OUTLINE

SOP-8-225-1.27

UNIT: mm

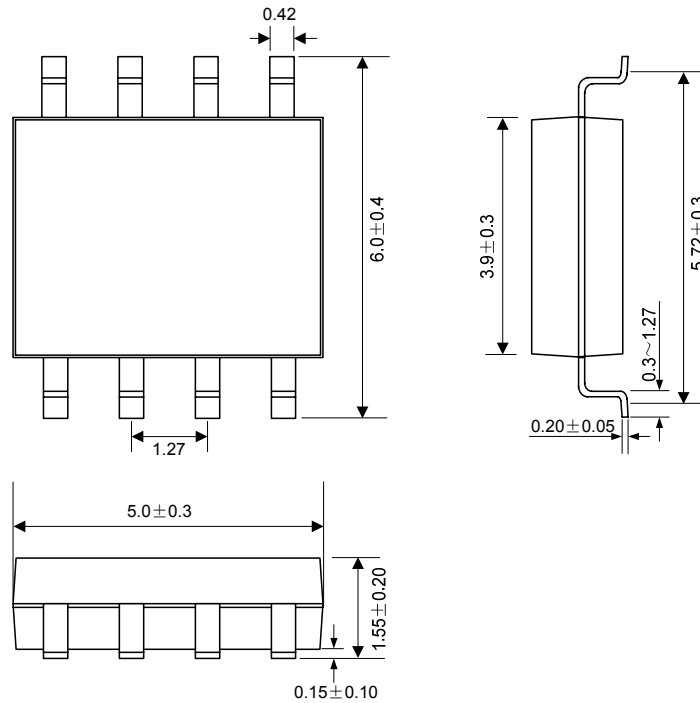

Note: Silan reserves the right to make changes without notice in this specification for the improvement of the design and performance.
Silan will supply the best possible product for customers.