

**Instructions for making a  
Piston Valve Engine  
from mainly junk materials.**

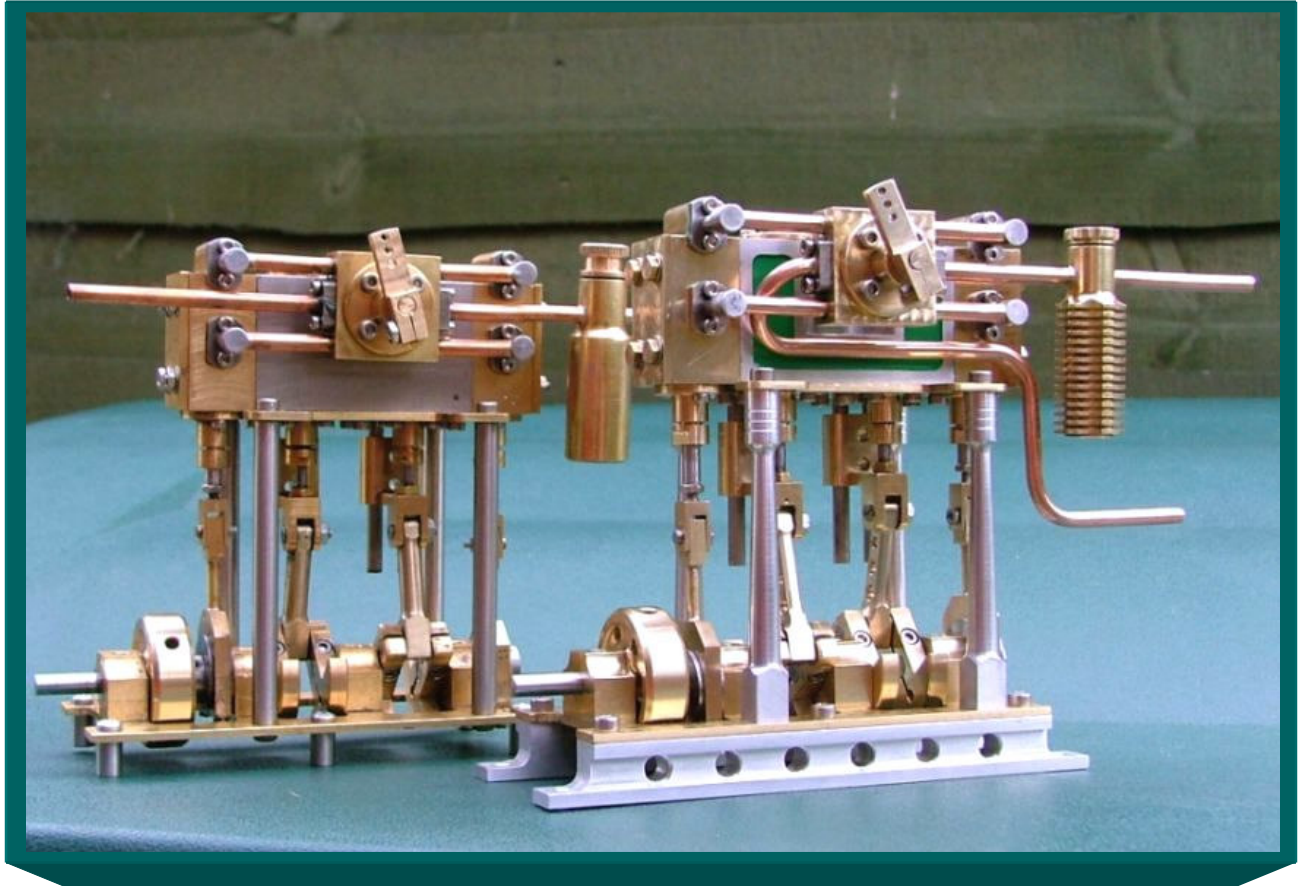

***Reproduced from postings  
by John (“Bogstandard”)  
on the  
Paddleducks Forum at***

<http://www.paddleducks.co.uk/forum/viewtopic.php?t=2872&postdays=0&postorder=asc&start=0>

Here are videos of my own design 10mm bore X 20mm stroke piston valve steam engine:

<http://www.youtube.com/watch?v=QwOhxvGc5VY>

here:

[http://www.youtube.com/watch?v=l8UCWr\\_BeqE](http://www.youtube.com/watch?v=l8UCWr_BeqE)

and here:

<http://youtube.com/watch?v=gTuET23Tkal>

## **Document Notes**

**The length of this document has necessitated its being split into smaller portions to comply with file upload limitations on host servers.**

**Consequently, it has been arbitrarily divided into six chapters, plus an appendix containing the design sketches in full size (also sub-divided into two parts). While this may not be as convenient to users as single file, it nevertheless permits the file to be made available in the first instance, and it will facilitate downloads for those with limited Internet access. (Note that internal document hyperlinks do not work in the PDF version of the document.)**

**The text and accompanying photos and sketches have been extracted from posts by “Bogstandard” (John) to the Paddleduck’s Forum over the period May to July, 2007, describing the step-by-step design and build of a model steam engine.**

**Also included are those comments, suggestions and questions that were posted to the Forum during the build period and which are considered to add to the knowledge transfer by other members of the Forum.**

**For reference purposes, the Chapters contain the following pages:**

**Chapter 1 – Cover page to page 14  
Chapter 2 – Pages 15-29  
Chapter 3 – Pages 30-45  
Chapter 4 – Pages 46-60  
Chapter 5 – Pages 61-73  
Chapter 6 – Pages 74-84  
Appendix 1/Part A – Pages 85-100  
Appendix 1/Part B – Pages 101-113**

# Table of Contents

(If in MS Word, use "Ctrl-Click" to jump to desired page.)

CHAPTER 1.....	1
Introduction/Tools Required .....	1
Safety.....	2
Project Overview.....	2
Main Block - Now.....	3
Machining Notes .....	4
To Get Square out of Round .....	4
Metalworking Guides.....	5
Comment – Milling Vice Datum Face .....	6
Comment - Tolerance Adjustment .....	7
Drilling Block Holes .....	7
Reaming the Block Holes.....	8
Top Caps, Packing Glands and Pistons.....	10
Crossheads.....	12
CHAPTER 2.....	15
Main Block Mounting Holes.....	15
First Holes: Top caps and gland seals .....	15
Second Holes: Block Mounting Plate .....	16
“Tweaking” Tips .....	16
Engine Turning.....	17
Crosshead Support Bars .....	18
Building Up.....	18
Bearing Blocks .....	19
Tip- Lapping Bearing Blocks.....	21
Baseplate .....	22
Comment - Boiler.....	23
Crankwebs Part 1 – Blanks (and Flywheel) .....	24
Comment - Crankweb Fabrication & Jig .....	25
Milling Caution .....	26
Crankwebs Part 2 - Shaping.....	26
Crankwebs Part 3 - Crankshaft Assembly.....	27
Comment – Crank Positioning .....	29
Comment – Crankshaft Construction.....	29
CHAPTER 3.....	30
Eccentrics .....	30
Conrods .....	33
Question – What Speed/Reverse Control? .....	33
Comment – Fourth Main Bearing .....	34
Steam Chest Intro (Piston Valve Control Block).....	34
Steam Chest – Part 1 .....	35

# Table of Contents

(If in MS Word, use "Ctrl-Click" to jump to desired page.)

Steam Chest – Part 2 .....	36
Comment – Drilling Deep Holes - Introduction.....	39
Comment - Small Boring Tool.....	41
Comment – Deep Hole Drilling - General notes.....	41
Response – Deep Hole Drilling.....	41
Steam Chest Blanking Plate .....	42
Response – Deep Drilling, Tooling Availability.....	43
Comment – Tapping Holes .....	44
Response – Helicoils, Spool Valves.....	44
Comment – Cutting Fluids .....	45
CHAPTER 4.....	46
Initial Assembly .....	46
Tip – Reamers .....	46
Prepared for 1 <sup>st</sup> Run.....	47
Comment – Regulator/Throttle, Video.....	48
Response – Video, Throttle.....	48
Spool Valves .....	48
Explanation – Valve Operation.....	50
Comment – Variation in Engine Speed.....	51
Response – Speed Variations .....	52
Comment – Running on Compressed Air .....	52
Response – Compressed Air .....	52
Eccentric Straps.....	53
Eccentric Connecting Joint.....	54
Piston Valve Packing Gland.....	55
Comment – Live Steam.....	56
Steam Flanges - General .....	56
Steam Flanges – Holes and Tubes.....	58
CHAPTER 5.....	61
Silver Soldering.....	61
Silver Solder - Problems .....	63
Flanges – Drilling Out.....	64
Steam Control Block – Part 1.....	65
Comment – Pickling Solution Options.....	66
Response – Pickling Solution.....	66
Steam Control Block – Soldering.....	67
Comment – Chamfer? .....	68
Response – Chamfer.....	68
Comment – High Silver Content Solder .....	69
Steam Control Block – Part 2.....	70
Lubricator .....	73

# Table of Contents

*(If in MS Word, use "Ctrl-Click" to jump to desired page.)*

CHAPTER 6.....	74
Valve Timing.....	74
Question – Match Marking and Torque Settings .....	77
Response – Match Marking and Torque Settings .....	77
Tip – Packing Steam Glands .....	77
Comment – Finding True Dead Centres .....	79
Tip – Locating Top Dead Centre.....	81
Comment – Lack of Comments .....	82
Custom Engine .....	82
Question – Milling the Custom Block.....	84
Answer .....	84
Question – Tightening Bolts .....	84
Answer .....	84
APPENDIX 1 – Design Sketches.....	85

## CHAPTER 1

### Introduction/Tools Required

Having carried out a full site poll, half way down a topic somewhere and having immense response, really, I have decided to show how I build my engines from scratch (and junk), hopefully to inspire at least one person to have a go.

This opening post will be to try and convince you that making is not too difficult or overly expensive if you just have a few basic engineering tools.

Its always nice to have a fully equipped workshop, but even by buying a cheap lathe, Arc Eurotrade do one for just over £100 with maybe another £50 for some basic bits to go with it, can work wonders for your modelling, not just engineering, you can make most of your metal, wood and plastic fittings yourself.

A small vertical slide to fit the lathe will allow you to do not only basic milling but more complicated things as you get used to it. In fact what I do is use the machines to make more bits for the machines. An el cheapo drill press is a worthwhile investment, and can be obtained everywhere for just over £30.

For basic hand tools I use an engineers square, a little gizmo for finding the centre of roundish thingies, its actually called a centre square; again you can buy sets of these from somewhere like Chronos for just over £25 (this is great, spending someone else's money).

A selection of files, scribe, a good six inch rule, centre punch, hammer, the list goes on, but most people have the necessary things already, you can buy purpose made deburring tools, but I use a Stanley knife, by scraping the sharp edges at 45 deg, instant deburr, just change the blade every couple of months.

A flat surface and a sheet of very fine wet & dry takes care of lapping any faces, I used a piece of plate glass until recently, in fact it was the platen glass out of an old photocopier, (it only needs to be about 12" square), I had used it for about the last ten years, not just for lapping but anytime I needed a flat surface, just scrape the glue off before using it to lap. Unfortunately, glass, big lumps of metal and fumbling fingers don't mix.

A cheap digital vernier calliper is a very good investment. Last one I bought was about £9 from Aldi.

Please bear in mind, with the machinery I have I can easily remove 5 or 6mm at a time, with a very small lathe or miller you will be lucky to remove one tenth of this, so you have to do a lot of small cuts. Usually the larger the machine the better, what will do a lot will also do a little, but not the other way round.

I am not saying that you could build an engine like this on the small lathe that I mentioned, but I would love you to prove me wrong. That was just to show that it needn't cost a fortune to start in engineering.

Now a few of my famous drawings showing the basic setup for calculating what is needed. This engine will not be a good looker by any stretch of the imagination; it looks very spindly, that is because again I have gone for the same bore and stroke 10X20 long stroke.

The next bit I submit will be even more long winded than this, because I want to mention a little about safety in a workshop environment. It needs to be done, and I promise, only the once. I have picked up more body parts from people alive and not so alive than I care to remember, so I can talk thru experience.

Digest this lot if you can, will do the next post either late tonight or early tomorrow. It will get better.

# “Bogstandard”: Building a Steam Engine from mainly Junk Materials

## Chapter 1

### Safety

Before I go any further, the most boring bits, but the most important. Ignore the warnings at your own peril!!! If you can't follow the basic rules, you shouldn't be anywhere near this post!!!!

From now on alcohol is banned from the workshop. Well that's got rid of 99% of the readers; we'll just carry on without them. In fact I'm most probably writing this post to myself.

Safety is a must, the eyes need careful protection, without them your modelling days are over; get a pair of safety glasses, AND USE THEM!!!!.

Machinery has no feelings; it will take your fingers off just as easily as it removes metal. Keep your bodily bits away until the machine has stopped. Long hair and shirt cuffs have an affinity for moving parts. Remember, don't become another piece of your latest project.

Metal that has been machined produces heat, and a lot of it. When I'm cutting some tough stuff it actually glows. Let it cool down before you touch it, and for goodness sake don't drop hot metal into water to cool it down, you might find that the metal has become hard as glass and you won't be able to do any more machining operations on it.

When metal has been machined, very sharp edges are produced; it will cost you a fortune in plasters. Don't put away a piece of metal until it has been properly deburred. In fact I deburr after every operation, if you don't, aside from the safety aspect will, if put against a datum face, will throw all your machining calculations out of the window.

It seems mundane, but getting splinters of metal in you skin can have drastic repercussions. Get a piece of brass embedded in your skin and leave it for a few days, the puss filled, weeping, gory open festering wound will wish you had got it out with a pair of tweezers as soon as it got in there. Remember there will be minute bits of metal everywhere, keep your hands away from it, sweep it up or better still get an old vacuum in there and suck it up as often as needed.

If you can add any more please do, I can't think for everyone, it is up to you to keep yourself safe and healthy, no-one else - YOU!!!. In fact in industry you can be prosecuted for having an accident, lose your fingers, get prosecuted, what a bummer. But you only do it the once. Lecture over, it does get better, but it had to be said.

### Project Overview

#### The Main reason you are reading this.

**Project** - To build a twin cylinder slide valve steam engine with the same bore and stroke as my previous oscillator, namely 10mm bore x 20mm stroke. This will allow parts designs from my previous engine to be used with this one. This will save a lot of time having to design new parts. All measurements are metric. Hopefully there will be no 'bit' measurements; I will try to keep everything to the nearest 1/2mm. I am also building in a few adjustable bits for those of us who are not quite as accurate ([Pic 01](#)).

Please be aware that I design and make as I go along, aided by a few sketches. If anyone wants to build one you will have to strip it down and measure it

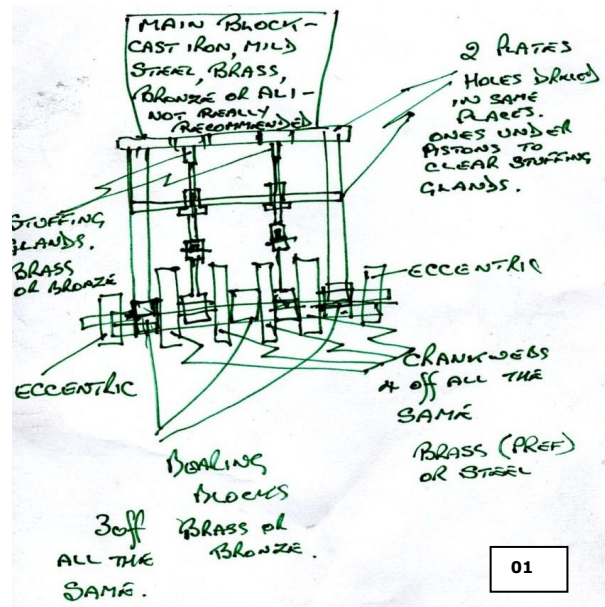



“Bogstandard”: Building a Steam Engine from mainly Junk Materials  
Chapter 1

up, and give me a copy of the drawings.

Or else ask and I will post what workings sketches I have. [Pic 02](#) and [Pic 03](#) are more examples of the type of sketch I'm talking about and depict the other key dimensions of the engine.

I will be building two engines in parallel so if you see two of everything don't worry, I am hopefully going to make one horizontal, and not by drinking alcohol.

Most of the raw materials for this build will come from the yard of many skips, or have been donated freebies from people that say "give it to that nutter John, save us having to take it to the tip". Little do they know about the cost of raw materials!

95% of my raw materials for building are not the correct size or shape - you have to go with an open mind and envisage what is in there trying to get out. I expect this engine - excluding fasteners - to cost me less than £10 in raw materials. Your local scrap man will become your best friend, slip him a couple of quid and he will be happy to hack old material into smaller bits, it will save hours in the workshop trying to cut it down yourself.

Throw no materials away. If while machining say a bit of brass and you cut off a 10mm long piece to get to size, don't throw that piece away, if you cut a bolt down, anything you cut off over say 6mm long, save it, great for making studs and joiners, saves time as well. Nothing is truly done for until it can no longer be used for anything else. It is people that don't follow these rules that get me all the raw materials from the scrapman.

The one thing that I do invest in is good quality fasteners, and I get them from here - <http://microscrews.easywebstore.co.uk/>. If it is not on the site just give them a call, only about 10% is shown on the site but they stock everything in stainless screwed fasteners, but only in metric I think, up to 4mm, and very reasonably priced as well. By the way: I have no affiliation to these suppliers, other than being a very satisfied customer

What I do is during the build I use any old crappy screws that I have lying around, and when the engine is up and running I put shiny new ones in.

**Main Block - Now to start (and hopefully finish!)**

Metal for the main block or 'How to hopefully recycle a useless bit of metal into a bit of metal with a use'

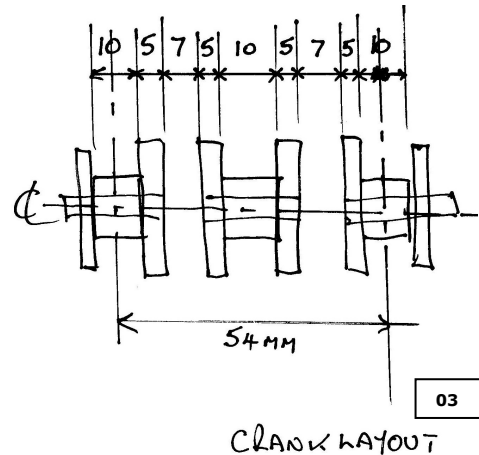
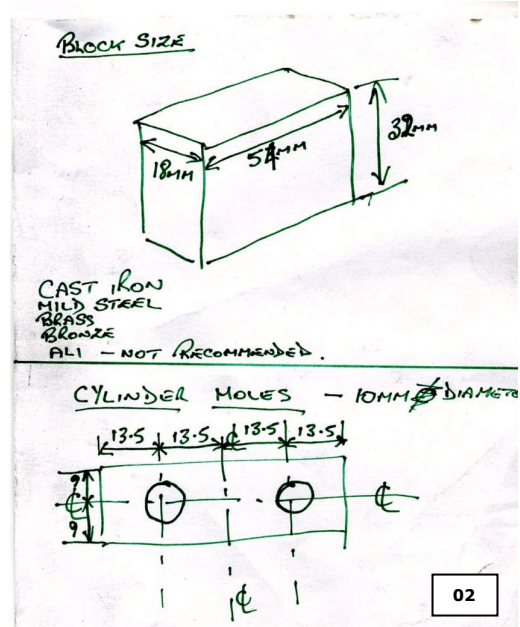

Pic 04 - The junkman's mull, gently eased apart to show the tempting secrets within.

Pic 05 - With even more teasing further treasures are revealed.



# “Bogstandard”: Building a Steam Engine from mainly Junk Materials

## Chapter 1

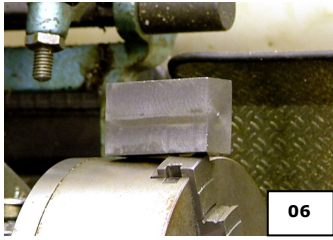

Pic 06 - After an hour's hard fumbling the sheer beauty is revealed, silky smooth, soft to the touch and a delight to fondle.

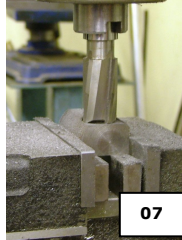

Pic 07 - Hacking off the outer skin to get a nice square block.

Not bad for a lump of scrap cast iron from the scrap yard that cost 30p (35mm cast iron bar, over £10 if bought from a metal supplier, over 90p per inch). Will be able to get about 6 engine blocks (5p each) out of one sash weight and is most probably up to a hundred years old and you won't get much better seasoned material than that.

This has been a long haul post but it sets things into the correct frame of mind. Just to reiterate:

- safety first and foremost,
- clean and deburred,
- get to know your friendly scrapman,
- don't be put off if you bodge it up, and
- if it can be put right it was never wrong in the first place.

Lay back a little. Metal doesn't just up and run away out of your chuck or vice (unless of course you didn't tighten up enough then it will chase you round the workshop), so take your time, the world won't end if you don't get the bit machined tonight, go and have a pint, be nice to the missus for a change. It is when you rush, get tired, fed up or whatever that accidents and mistakes happen, it will still be there in the morning. You are not in a production environment, unlike Sandy, who has to get things out on time otherwise his employees don't eat. Get to enjoy yourself, because if you don't enjoy it you shouldn't be doing it.

I don't use tolerances (this is a designed figure that you can work to, and if kept within the figures will ensure that the mating parts will fit together and carry out their designed function). Because these engines would be classed as prototypes, I make everything to fit individually. If you go slightly over or under on the bores, make the pistons to fit, the grim reaper won't call just because one bore is 0.02mm bigger than the other. So I try to keep to exact size, but I don't worry if not.

### **Machining Notes**

To get an idea of using a vertical slide on a lathe, when you see a picture of my milling setup, swing the picture thru 90 deg and imagine the cutter being in your lathe chuck and the vice as being the vice on your vertical slide, you can do everything I can do with my miller, maybe not as quickly, but as mentioned above, why rush.

Use a dial test indicator for setting the fixed jaw of your machine vice totally parallel and square to the cutting action of the cutter. This can be done without a DTI just by machining a piece of metal and measuring the results.

The fixed jaw of the vice now becomes your datum face, don't move it unless you really have to. After you have been doing any heavy cutting, check it again, just in case it has moved.

#### ***To Get Square out of Round.***

Put material in vice, and face off the side. Then clean off the swarf, deburr both cut edges and remount into vice putting the now flat face against the datum jaw. Take a cut across the face, this will give you two sides square to each other, again clean and deburr.

The face you have just cut goes down into the vice with the same datum face that you used before against the fixed jaw. I set my piece onto parallels and tap the material onto that until it just grips the parallels, that way I know that everything will be square and parallel. But if the jaw is square to the base of the vice you

# “Bogstandard”: Building a Steam Engine from mainly Junk Materials

## Chapter 1

should be ok.

Now machine the third side down to the required thickness, again, as usual, clean and deburr.

Put the first machined side down into the vice with one of the now machined and parallel sides against the fixed jaw, tap down the material and then cut the fourth side down to required thickness.

If all is well you should now have a piece of bar that has opposing faces parallel and square to adjoining faces.

If you can get this right everything else is almost easy.

### ***Metalworking Guides***

Here is a website to give you a few basic instructions in metalworking, and explains things a lot easier than I can - [http://www.nmri.go.jp/eng/khirata/metalwork/index\\_e.html](http://www.nmri.go.jp/eng/khirata/metalwork/index_e.html) . There is some pigeon English but most of it is understandable.

If there is anything at all that you don't understand, just go to Google and type in what you want, i.e. 'using a vertical slide' or 'how to use a boring bar in the lathe'; the answers to most questions will give you all the info you require and just add the sites to your favourites for later reference.

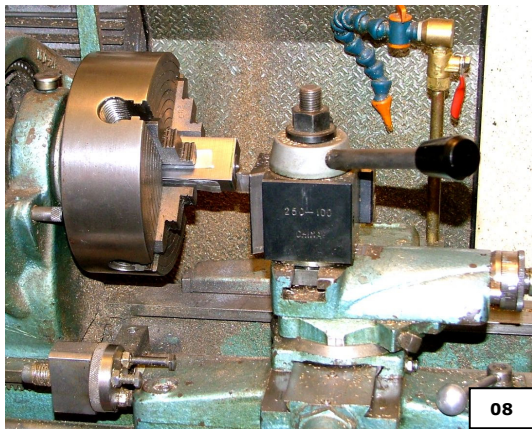

Pic 08 shows a lot more than you think.

I have already faced one end of the cylinder block, now is the time to get it to the right dimension.

At the bottom left and right of the picture are two of my most useful bits on the lathe. The right hand one is the saddle clamp that locks the saddle solid, the left hand one is a saddle stop that I made for this lathe, it doesn't have to be this complicated but it can stop you ruining your lathe.

It stops the toolpost going too far and hitting the chuck, usually with irreparable damage. This is usually a fairly simple thing to make and you will wonder how you ever lived without it. The way I use it for facing is bring the saddle to it and lock the saddle. Then I can use the top compound slide to give very fine cuts without having to worry about the saddle being pushed back by the pressure of the cut.

I am using my four jaw chuck to hold the material, the material doesn't have to be centralized when end facing, in fact with a little bit of ingenuity the whole block could have been machined in the four jaw.

I am a stickler for a good surface finish, and will spend hours lapping and polishing, so you will notice that I have used a bit of cut up drinks can (I prefer Pepsi Max, but almost any will do) between the jaws and the material, this is to protect the surface finish, chuck jaws are very hard and will mark most materials.

On the metal sticking out of the jaw, near to the cutting tool, you can just notice a felt tip mark near to the end. This allows me to rough cut up to that mark, leaving me about 1/2mm to go to length. Then I take a very fine facing cut (maybe 0.02mm: 0.001"). Then remove the piece from the chuck and measure the length. This will tell you how much you have left to come off to get to size. Remount in chuck with Pepsi Max, bring the tool to just touching the face then take your cuts, the last one being like before, very fine. You will find that you should have now a piece of material to the correct length.

The last bit in this picture is rather indistinct, that is the cutting tool itself. I started using one of these so called 'profile' tools about 5 years ago, and it is one of my most prized possessions in getting my own back

## “Bogstandard”: Building a Steam Engine from mainly Junk Materials Chapter 1

against lumps of metal. They are obtainable from a lot of places but here is about the cheapest - <http://www.rdgtools.co.uk/>

Go to the bottom of the page and all will be explained. I bought five tips for it when originally purchased - I am just on the last one now. The beauty of these is that when the tip wears you just turn it a few degrees and you have a brand new cutting edge, and the surface finish is superb. About £3 a year running costs, not bad, and it is used daily for facing, reducing to size and of course a little bit of profiling.



Pic 09 is the blocks finished to size, blued up (this is not really necessary, but you don't have to scribe such a deep line to see it) and marked out for the job tomorrow, namely putting the big holes in.

Oh! and a little message for Eddy, here is the first wart (or pimple), the block was a bit tight to get out of the rough cast material and is in fact 0.15mm (0.006") too short on the height, but as I said, don't worry; all I will do is take the same measurement off the top of the piston and all will be right with the world.

### **Comment – Milling Vice Datum Face**

*John.....Looks good so far, however, just a couple of additional tips for everyone.....when using a milling vice...*

#### **Quote:**

The face you have just cut goes down into the vice with the same datum face that you used before against the fixed jaw. I set my piece onto parallels and tap the material onto that until it just grips the parallels, that way I know that everything will be square and parallel. But if the jaw is square to the base of the vice you should be ok.

*This will only work well providing your milling vice, or vertical slide vice, are of high quality...cheap vices are just not true enough....The inside (datum) face of the fixed jaw must be absolutely vertical (90 deg.) to the top face of the vice base, which in turn must be set truly parallel to the cutter. Ideally, the top face of the fixed jaw should also be absolutely parallel to the top face of the vice base (if not then use the top surface of the base as your second datum), but on anything but a high quality, or tool room standard milling vice, it is highly unlikely that any of these requirements will be the case.*

*There are other methods, using an angle plate, parallels and suitable clamps, but I will leave it to John to enlarge on this for you, should he choose to do so...after all, it is his article.*

“Bogstandard”: Building a Steam Engine from mainly Junk Materials  
Chapter 1

**Comment - Tolerance Adjustment**

**Quote:**

Oh! and a little message for Eddy, here is the first wart (or pimple), the block was a bit tight to get out of the rough cast material and is in fact 0.15mm (0.006") too short on the height, but as I said, don't worry, all I will do is take the same measurement off the top of the piston and all will be right with the world.

*I would not be too concerned about 0.006" after all you have got, or should have, approx 0.031" clearance volume at each end of the bore...if you adjust the con-rod length (the big end or piston will I assume be screwed on) you can make this -0.003" at each end of the stroke...no worries.*

*BTW John, I hope you got the gist of my explanation on eccentric location/orientation...if not then let me know and I will try to explain it in a different way...sorry if it confused you, but it is an important detail.*

*As for standard direction of rotation....on single screw vessels the majority would have clockwise prop rotation when looking towards the bow from astern.*

*On twin, or multi screw vessels then Port side screws would turn counter-clockwise and Stb screws would turn clockwise...again looking from astern.*

*This is known as outward turning...in other words the topmost blades turn outwards, away from the rudder/s.*

Many thanks for the comments, all duly noted.

Hopefully the article will not now be as long winded. I just wanted to get across the basic understanding of machining metal and what is involved, and put over how I cope with the odd situations.

The eccentric bit did confuse me because you switched ends half way thru. The way I see it now, is that when viewed from the output end (the end connected to the shaft), engine going in a clockwise direction, with the nearest piston in the fully upstroke position, the eccentric will be 90deg to the right, the rear piston is on its downstroke and its big end at 90 degrees to the right (the same position as the front eccentric) and its eccentric 90 degrees forward of that at full bottom stroke, or should the rear piston be on its upstroke and its eccentric be at the same position as the front pistons big end? Or doesn't it matter?

When I asked about direction of rotation of props: as far as I'm concerned, on the full size it is pointy bit at front, blunt bit at back, don't know what's underneath, can't see it unless I get wet. On models, as far as I was aware, you always went for the safety factor and a single screw always went anticlockwise when viewed from the rear, so the shaft was screwing the prop on tighter (the same as the port side setup when viewing a twin output).

**Drilling Block Holes** - Now to get back on track.



# “Bogstandard”: Building a Steam Engine from mainly Junk Materials

## Chapter 1

I will sometimes mention a couple of words that need a bit of explaining and they are related. These are CONcentric and ECcentric.

**Concentric** means in our situation that the outside diameter has the same centre as the inside diameter, a good example is a well made washer.

**Eccentric** means the outer and inner diameters have different centres, like the holes on a button, stick it on a shaft and spin it and it wobbles up and down.

Found this site today - <http://www.ijitrain.com/vms/library.html> .Almost everything you need to know about using the things and operations I use on the lathe and milling machine can be found here. Be very careful though, if you are just starting out in machining the hours will fly by while surfing on this site. Videos and all sorts on here.



When drilling holes bigger than 2mm you should always if possible use a centre drill, if drilling large holes say of above 6mm, egg 10mm. Start with the centre drill, then use something like 4mm followed by one around 7mm, then 9mm and finish off with the 10mm. You will find that the holes will be a lot more accurate than stuffing a 10mm straight in.

For sheet metal drilling I find that cone drills do a wonderful job, they don't snatch when breaking through. Pic 10 shows centre drills and cone drills (another great buy from Aldi).



Pic 11 shows the steps I will use to drill the bores through the main block. I will finish off with a 10mm reamer, but if doing it on a lathe you can bore the holes or just drill them either mounted into a four jaw chuck or vertical slide, but you must make sure that you don't drill into the holding chuck or vice. Two other things to note on this picture. The first is showing block sitting on parallels to allow drills to penetrate right thru without doing any damage. The other is that just behind the block is what is called a back stop, this allows me quickly to flip the block around and without having to re-measure, drill the second hole. Backstops are also used on a lathe; I will point it out when I come to use one.

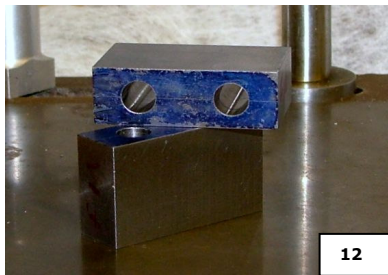

Pic 12 shows cylinders bored and reamed. The surface finish in the bore looks really grotty, but in real life they are like a mirror.

Work has now finished on the blocks for the time being, the next bit is to make and fit the pistons and rods.

### Reaming the Block Holes - Back to the article.

I said last time that we had finished with the blocks for the moment.

I forgot that not all of you will have the means to get a good enough finish on the bore: they will most probably vary from a slightly dull surface, thru what looks like screw cutting to digging out the hole with a hammer and chisel.

If you can borrow a reamer, and your hole is still slightly undersize, use one, otherwise this is how I would get an acceptable finish. You can go out and buy adjustable laps, but that costs a lot, just to get a couple of holes cleaned out, this isn't the totally correct way but it will be better than what you've got at the

# “Bogstandard”: Building a Steam Engine from mainly Junk Materials

## Chapter 1

moment.

Start with the largest hole, stick the last drill you used through them and wiggle about side to side, the one with the biggest wiggle is the biggest hole.

Mark the largest hole with a felt tip. Now chuck up a piece of material to make the lap out of, have it sticking out of the chuck by 1.5 times the length of the hole plus 25mm (1"), I use hard nylon but aluminium or brass will also suffice, I get better results with the softer materials.

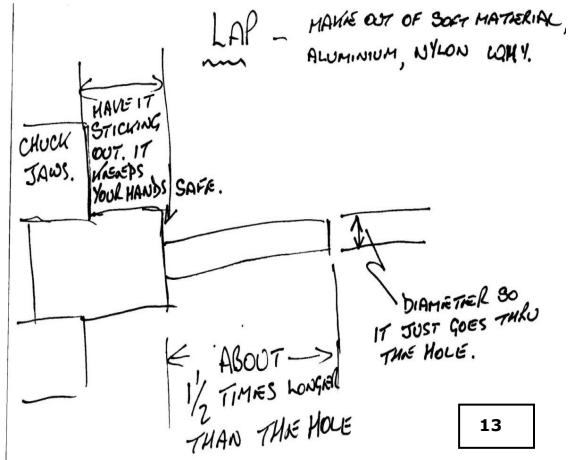

Carefully (no heavy cuts here, material sticking a long way out of chuck) and turn down the rod until it just pushes through the hole for a length of 1.5 times the length of hole (like [Pic 13](#)).

Now we need to spend a bit of money unless you are from the old school and have some in your garage. We need to buy some fine and coarse grinding paste, Halfords is about the cheapest at about £3 and you get a grinding stick with that as well. This quantity will last you for the rest of your life.

Dab a bit of the coarse stuff along the length of the lap, you don't need a lot. Get a piece of hardwood and with a rolling action in combination with turning the chuck by hand (you have stopped the lathe I hope) embed the

surface of the lap with grinding paste, what you are doing is making a very accurate round file.

Select the lowest speed on your lathe and switch on. Keeping well away from the chuck feed the hole to be lapped onto the lap, get ready to let go on this initial feed in just in case it bind up and sticks. If all is well the lap will be turning (without you going round with it) in the hole. Now just gently move the block up and down the lap in a sort of rotary twisting motion. You need to keep the lap fully into the hole at all times.

Change the block position 90 deg around the lap every so often, eventually you will get the feel and a rhythm going.

Do this for a couple of minutes, stop machine and check the bore, it should have started to smooth out. Repeat as necessary, wipe off, recharge, turn the block around and come from the other end of the hole, until the rough stuff has gone, then wipe off coarse grinding paste with white spirits and recharge with fine. Repeat the operation.

You should after a while end up with a nice round, parallel bore showing slight scratch marks on the surface, these scratches will help the bedding in process as they retain oil while the pistons and bores are wearing against each other.

Clean off the grinding paste and turn down the lap to fit the smaller hole, and repeat the process again. When finished give the bores a very good clean out to get rid of any remaining grinding paste.

If you remember from before, the pistons are going to be made to fit the bores, so they don't need to be the same size.

Put the lap you have just made in a safe place, you might make something else where you can readjust the size and use it again. I will do the pistons in the next article; it will give time for the batteries to recharge on my camera.

“Bogstandard”: Building a Steam Engine from mainly Junk Materials  
Chapter 1

**Top Caps, Packing Glands and Pistons (Sketches at Pics 21 & 22)**

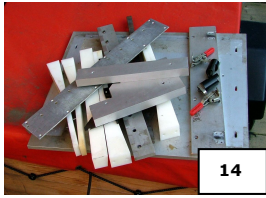

Anyway, remember how I said in the first posts about scrap materials and turning nothing away. A friend (yes I do have them) came at weekend and dropped this lot off (Pic 14), they were moving to a new factory and were dumping old fixtures, so he thought of me and brought the metal; the bottom plate is about 15mm thick and 600mm square. So as I said, tell everyone what your hobby is, and sometimes Christmas comes early.



Pic 15 is some hex bar offcuts from the scrapyards for less than £1 and turned down to 18mm for top caps and stuffing glands, there is enough here for 4 or 5 engines.

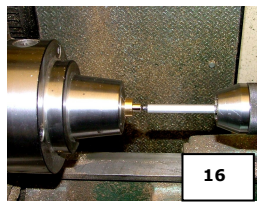

Pic 16 is a tip how I get all my holes to the same depth. This can be used anywhere you use a twist drill. Get a piece of tube just a bit bigger than the drill and slip it over the end, then adjust the position of the drill to the correct depth sticking out of the end, so when you get to the correct depth the tube is trapped between the drill chuck and the job, so stopping the drill going any deeper.

Hopefully in a couple of days I will be able to post more pictures of where I am up to.

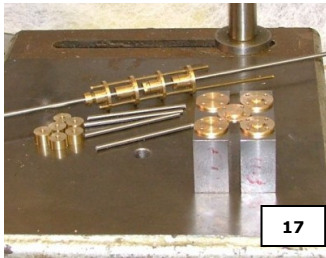

There's no stopping me now, a pack of real paper and when I went to the bank I found a brand new pen, but some idiot had chained it to the counter, but being a prepared engineer I just happened to have a set of bolt cutters in my inside pocket.

I am not going to go thru all the operations from now on, just tips when they are being machined: if you need to know how to do it just ask.

Pic 17 shows top caps, packing (stuffing) glands and raw pistons (always make more than you need).

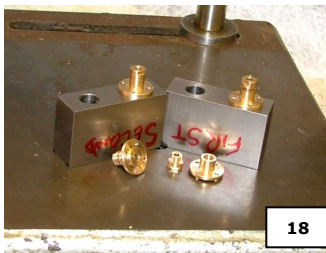

Pic 18 is the finished packing glands.

Pic 19 shows piston rods in blank pistons.

Pic 20 shows the finished pistons, with one having had an o-ring fitted.

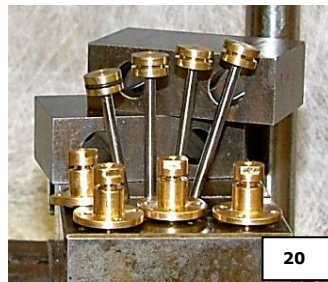
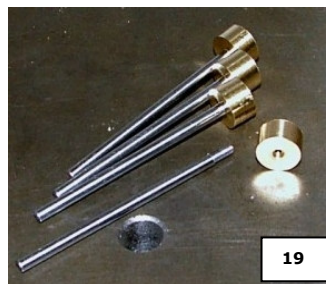



“Bogstandard”: Building a Steam Engine from mainly Junk Materials  
Chapter 1

**TIPS:** First tip is for packing glands (Pic 21): make the screw-in bit first, do not drill any holes thru them until you get to the stage where they can be screwed together with the main part still chucked in the lathe. Then screw them together and drill your hole thru them, this will keep them concentric. Keep them together in matched pairs.

For the top caps, you can have them as high as you want - on the picture there are two different top profiles.

I left the pistons until last, the sketch (Pic 22) shows the finished size but make them initially to about 10.5mm diameter and 6mm long. The recess in the piston thread is to allow the thread to screw all the way in and sit against the shoulder on the shaft. Assemble the two together with Loctite and leave for 24 hours. Your chuck must run very true for turning the piston OD - it has to be as concentric as possible. If this is not possible, ask and I will draw a sketch to show a very easy way to do it.

**DO NOT** remove the piston assembly from the chuck until it is finished. Turn the piston to length first (if you make the thread a little longer as well you will end up with a nice flat topped piston). The OD is turned down in minute cuts until it only just fits inside the cylinder (no floppy fits here, if so start again), stick a piece of very fine wet or dry paper or emery to a flat stick of wood and hold this against the side of the piston (no heavy pressure) until the piston just starts to slide nicely in the bore, you are looking for a clearance of about 0.02 - 0.03mm (0.001"-0.0015") if you can.

The groove is put in half way along (I make mine to fit a Viton o-ring) and can be left empty so it uses collected oil to form the seal or it can be packed with either gland material (messy) or twisted up plumbers PTFE tape (fiddly) or like myself an o-ring.

Keep these assemblies **matched to the bores**.

**IMPORTANT** - ALL sharp edges on the piston need to be 'knocked' off with a file while still in the chuck, this will allow the oil to penetrate correctly for lubrication, but more importantly the sharp edges actually break down the oil preventing it from doing its job properly.

All holes that ANY shafts on the engine pass thru should have a small chamfer at each end - this is to allow oil penetration.

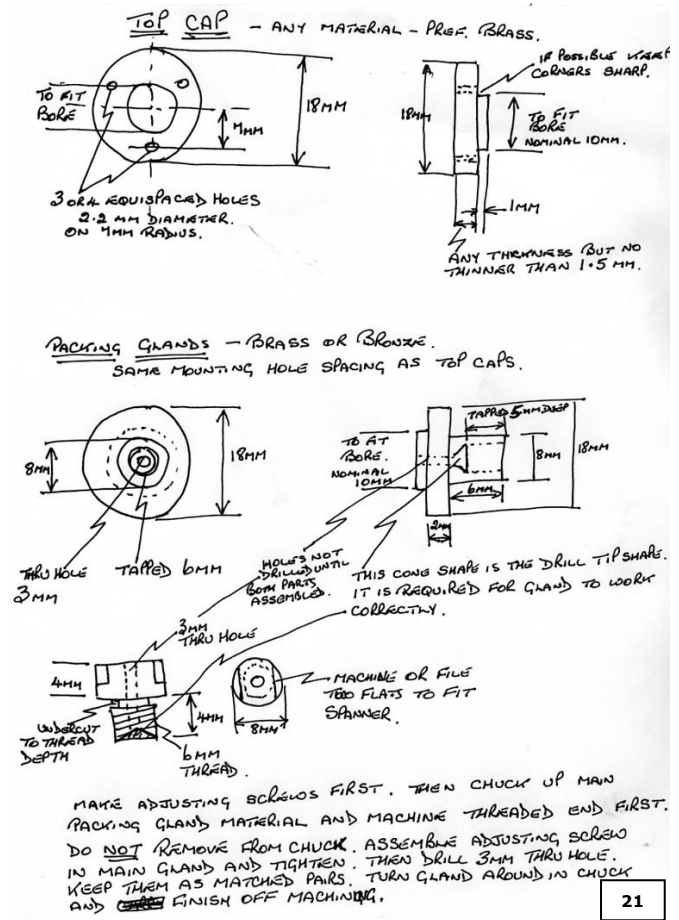

# “Bogstandard”: Building a Steam Engine from mainly Junk Materials

## Chapter 1

PISTONS - BRASS OR BRONZE

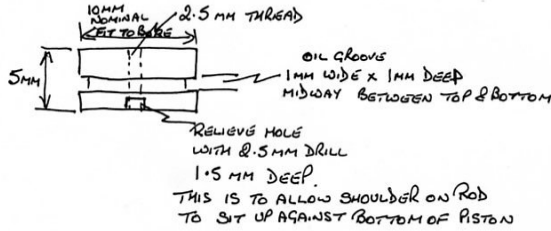

PISTON ROD - 3MM DIAM. STAINLESS STEEL OR SILVER STEEL

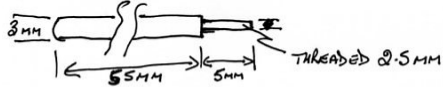

THE 55MM ROD LENGTH IS THERE TO ALLOW FOR MODIFICATION AS AND WHEN NEXT AREA IS FINISHED.

WARNING - KEEP AWAY FROM HATCHED AREAS BOTH TOP AND BOTTOM. THESE ARE RESERVED FOR PORT DRILLING

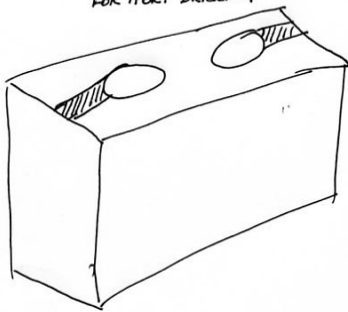

22

Please take note of the sketch with the block on it ([Pic 22](#)): this is nowhere near finished at the moment so you have to avoid certain areas if you want to start putting the end caps and packing glands on.

The rods on the pistons are not finished yet; I am still designing and making the middle part of the engine, so these will be finished off when all this area is proven to work.

The rest of the sketches for **TOP CAPS**, **PACKING GLANDS** and **PISTONS** are self explanatory.

## Crossheads

The crosshead is the link between the linear motion of the piston shaft and the rotary motion of the crankshaft/conrod. There are a lot of side loads imparted onto the piston and rod by the conrod so the crosshead transfers this side load to a more substantial bearing area than the bottom of the packing gland. I hope I explained that right, I am sure someone will let me know if I didn't.

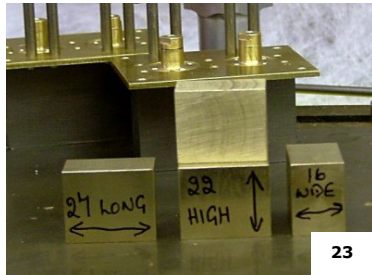

The crosshead blocks that I am showing now are going to be the hardest part on the engine to make; if you can make these you will have no further problems making this engine.

Pic 23 shows blocks prepared for machining, fully deburred and cleaned. All holes to be put thru this block should be done before any other work; this will make sure that they should be square and parallel.

"Bogstandard": Building a Steam Engine from mainly Junk Materials  
Chapter 1

Pic 24 shows two blocks fully machined the raw one on the left and the partially dressed one on the right, you can use the raw version with no problems but I always think that the components should look the best they can.

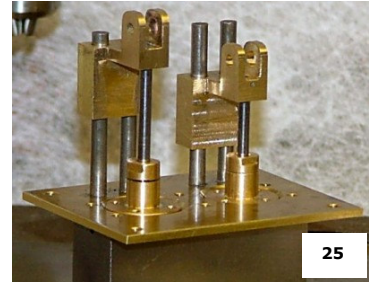
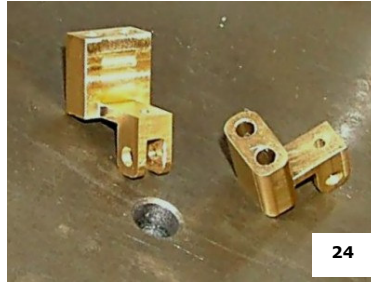

Pic 25 shows how the crossheads will fit onto the engine. The support plate and crosshead rods are not finished yet; these will be in the next post, plus a little bit of machining of the block to a stage where we can start to think about the crankshaft.

The sketch (Pic 26) should be self explanatory. Pic 26A shows why we need a crosshead(s).

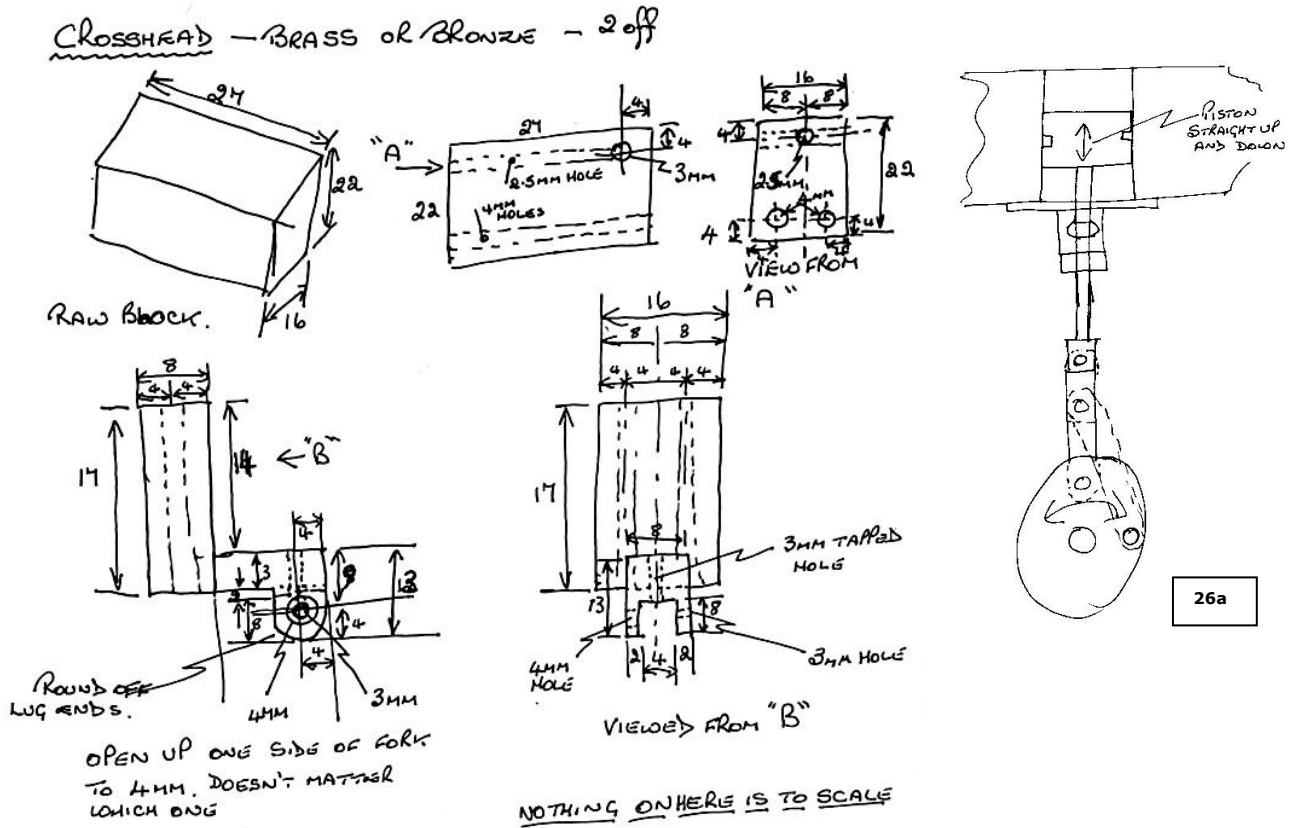

ALL THE THRU HOLES SHOULD BE DRILLED BEFORE ANY OTHER MACHINING IS CARRIED OUT. AFTER THE FORK IS MACHINED OPEN ONE SIDE ONLY TO 4MM. IF USING A MACHINE 4MM REAMER FOR LONG HOLES. DO IT AS YOU DRILL THE HOLES. THE 2.5MM HOLE ISN'T TAPPED OUT UNTIL ALL MACHINING IS FINISHED - ENSURE TOTALLY SQUARE AND PARALLEL TO 4MM VERTICAL HOLES. THE HOLE DOESN'T HAVE TO GO ALL THE WAY TO THE CROSS DRILLED HOLE, IT CAN BE STOPPED ABOUT 2MM SHORT (ABOUT 19MM DEEP)

26

“Bogstandard”: Building a Steam Engine from mainly Junk Materials  
Chapter 1

*John.....I am so pleased to see that you have fitted a proper crosshead arrangement...looks great and should work just fine.  
When I looked at your initial sketch (1st post) and saw the arrangement this showed I was going to comment on it, however, since you were still in the design stage at that time I had a feeling you would re-consider the original method (which would not have given any support at all, at least not after the first few minutes of running)...well done!*

Thanks for the encouragements lads, shame I can't get better photos.

You were right Sandy, after a couple of hours pondering I knew exactly what was required for the crossheads, the problem is keeping it easy enough for people to have a go, there are so many designs that could have been used but this was one of the simpler ones, and keeping within the format of no complicated decimal places is another restriction. Also for the few who cannot be as accurate there has to be an inbuilt element to allow for 'tweaking' to get the parts to run correctly.