

1

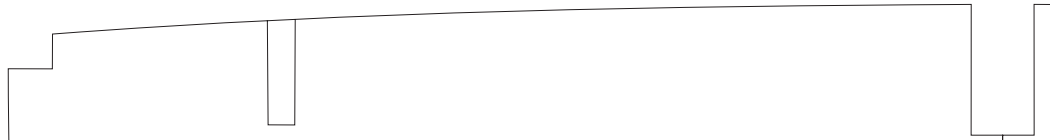

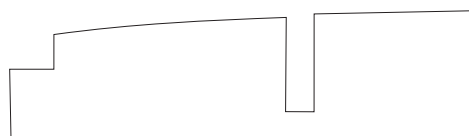

6

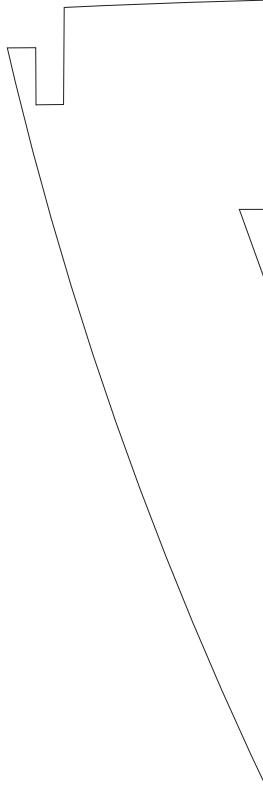
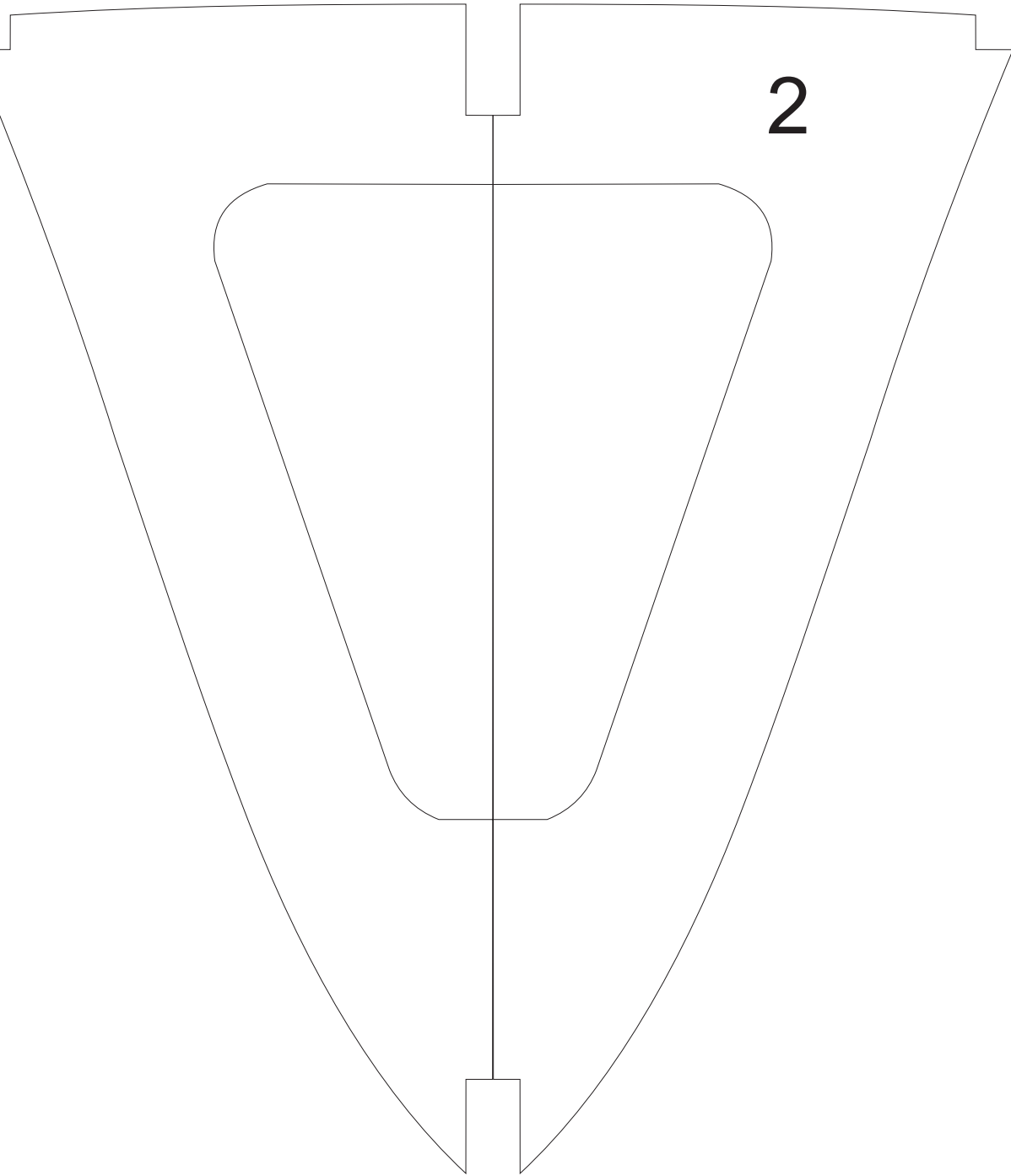
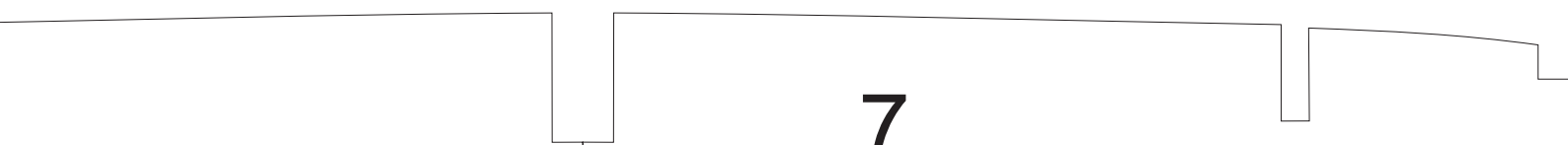
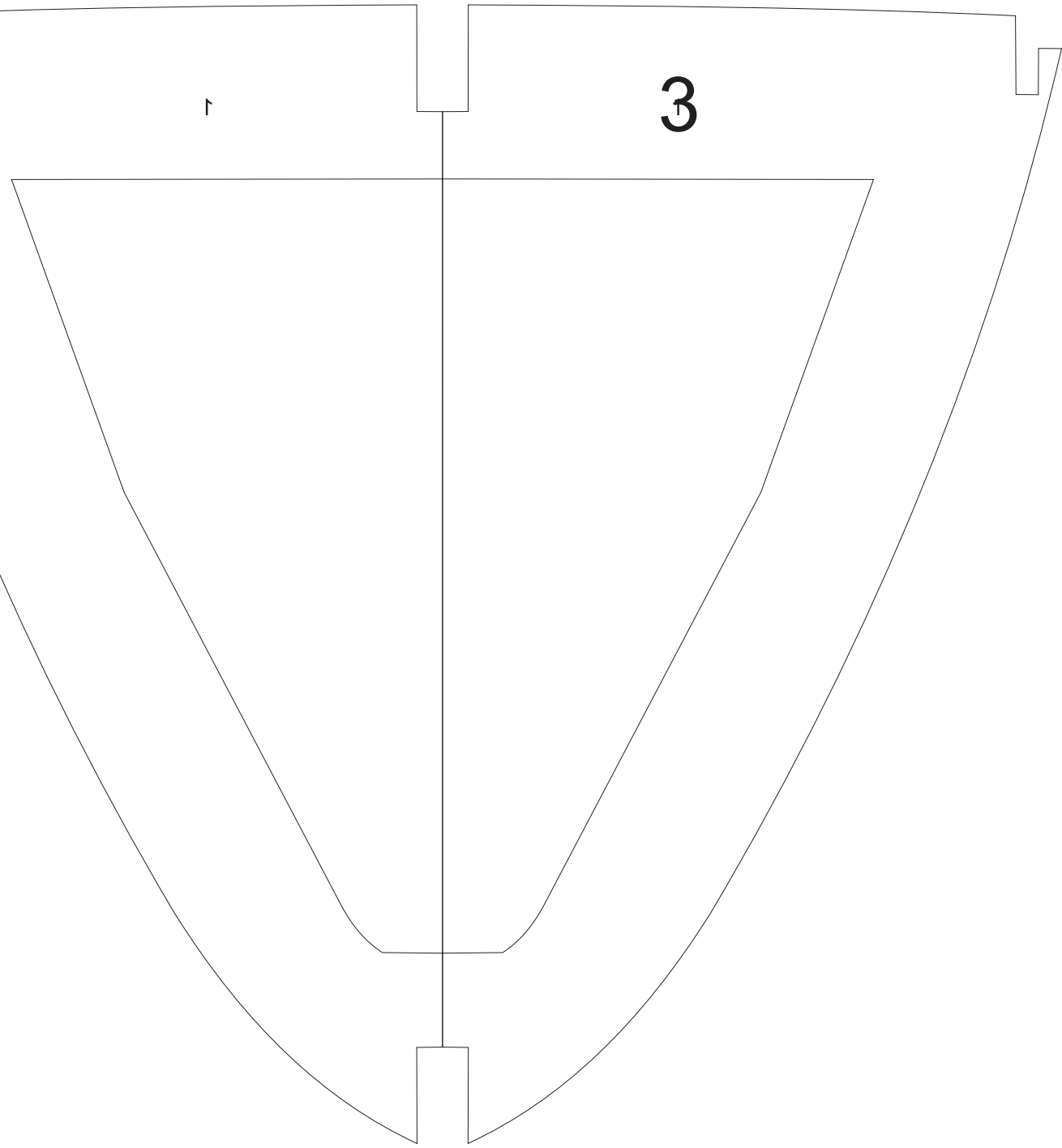



4

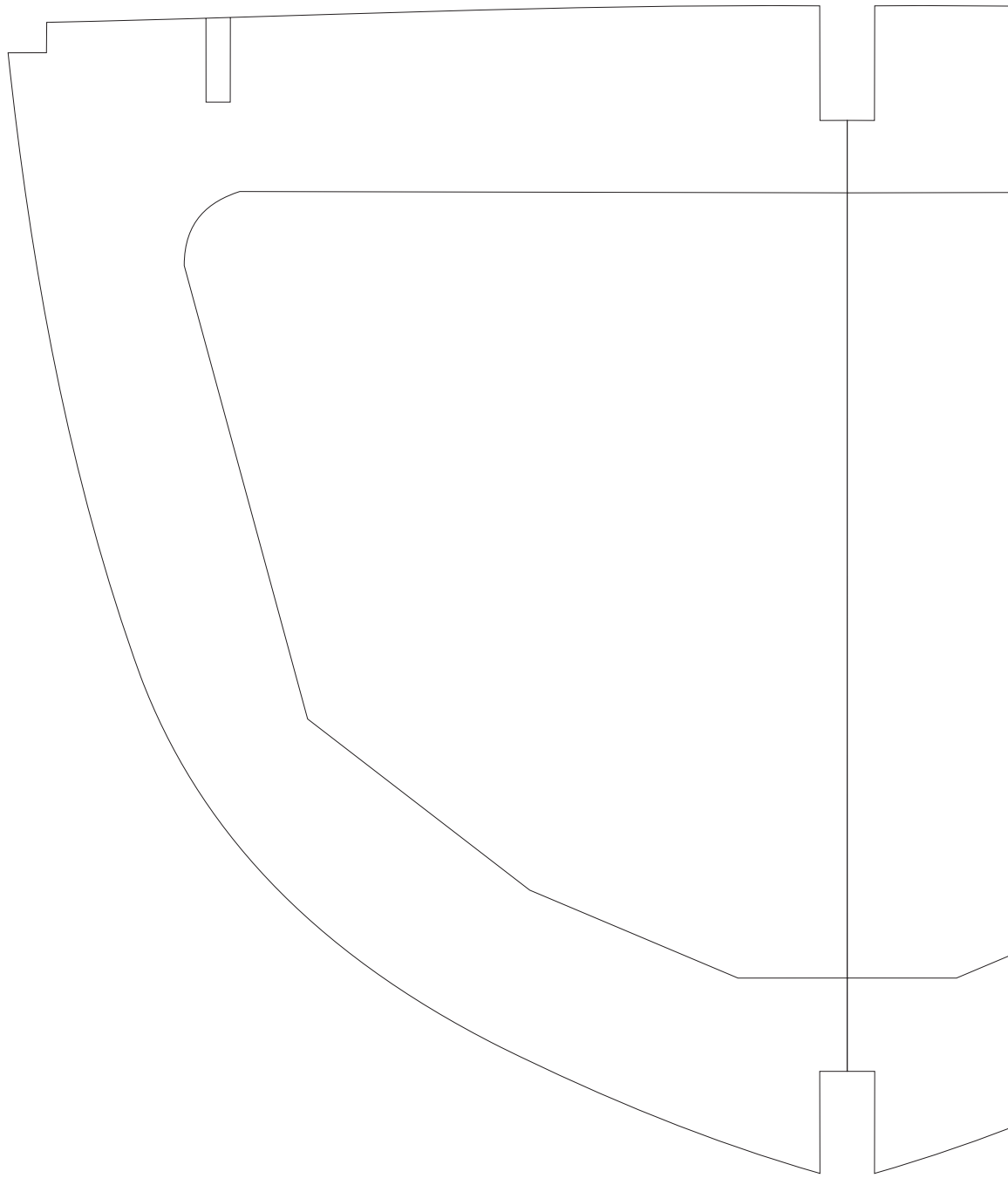
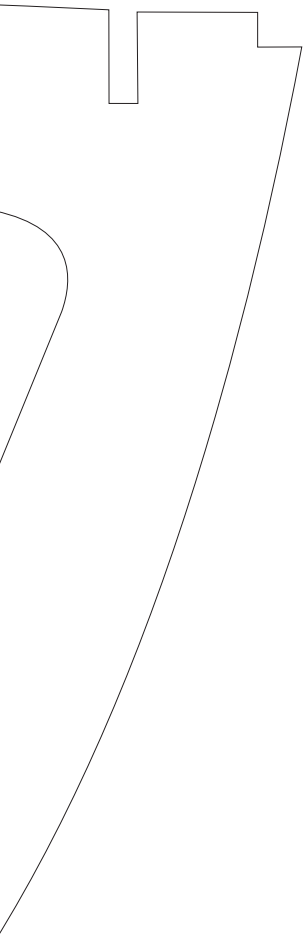

5

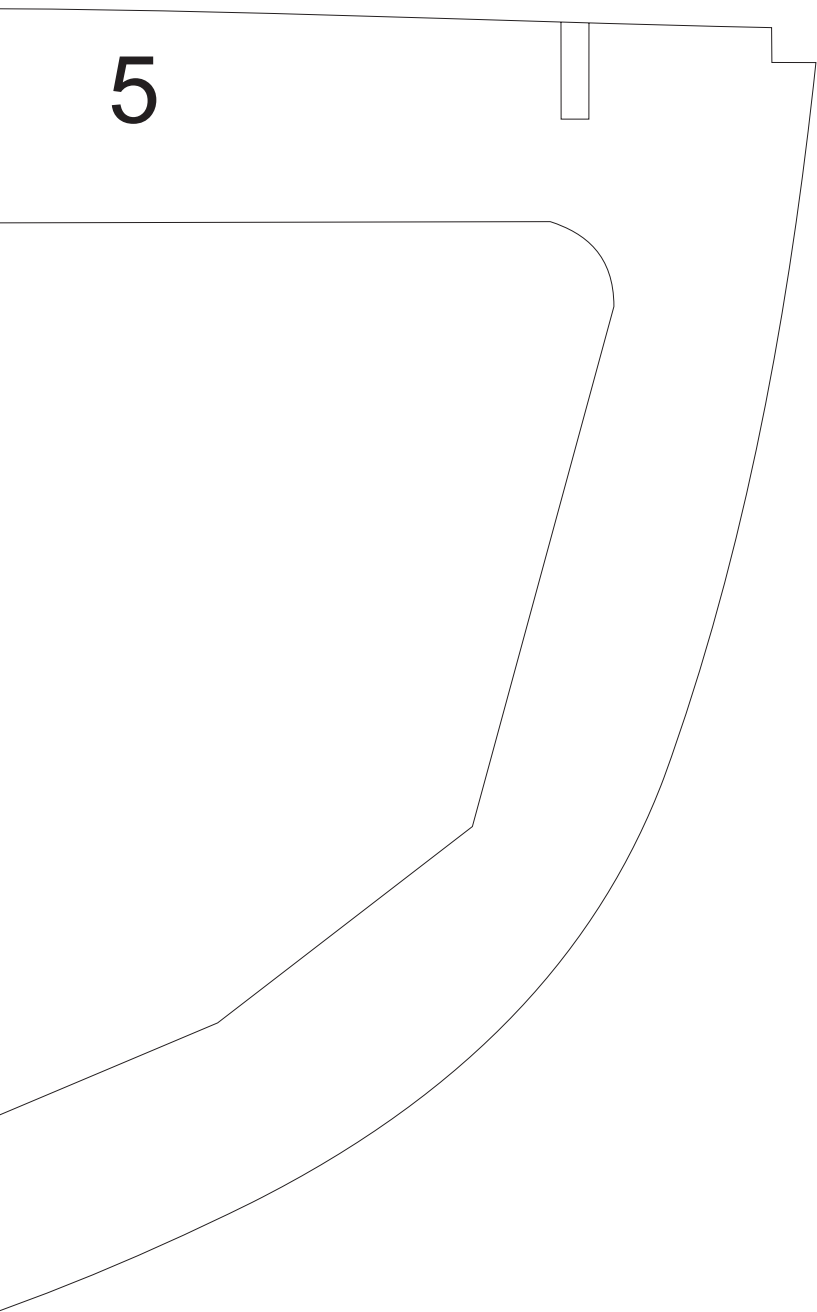

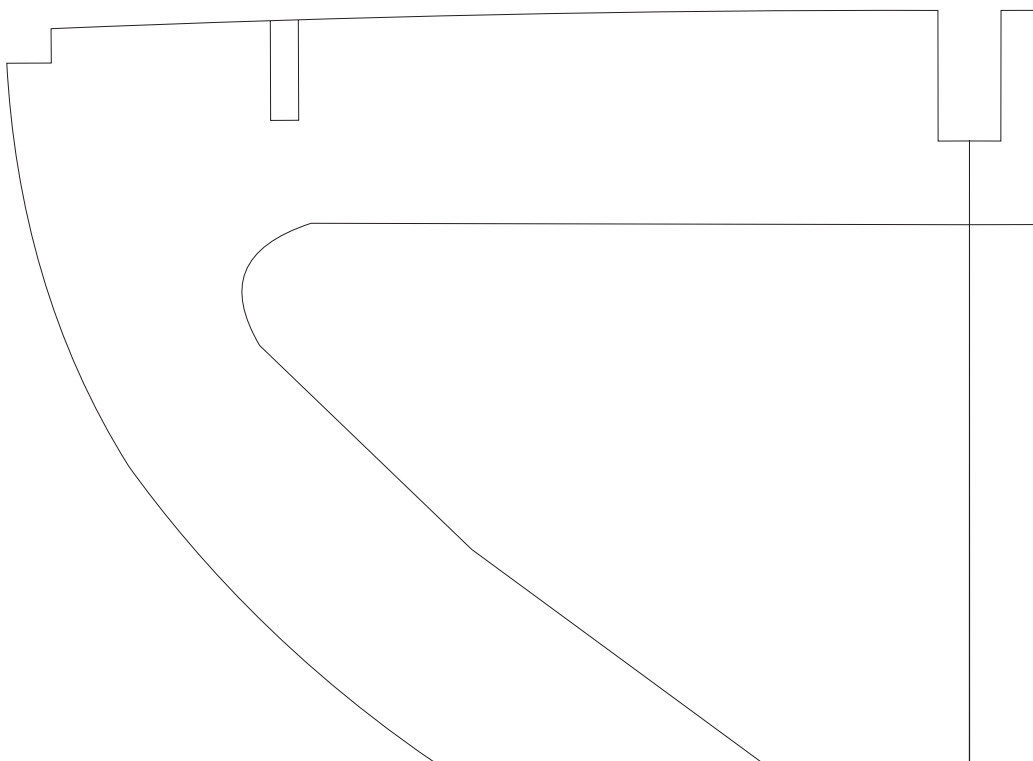
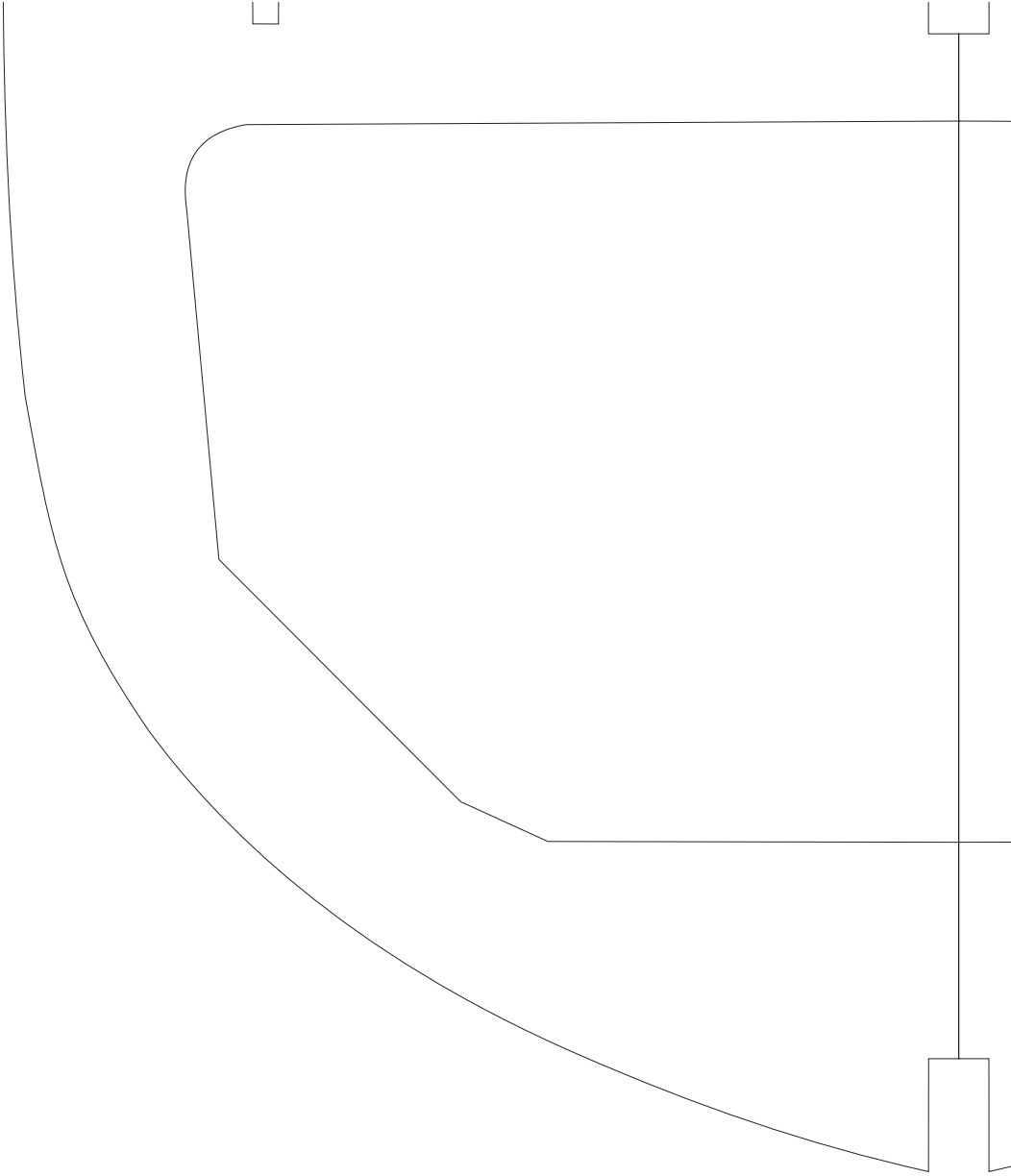

6

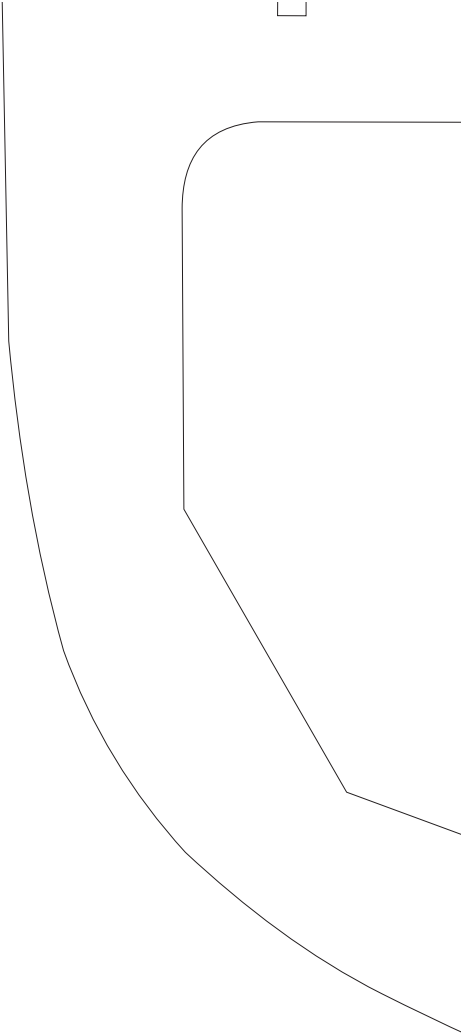

10

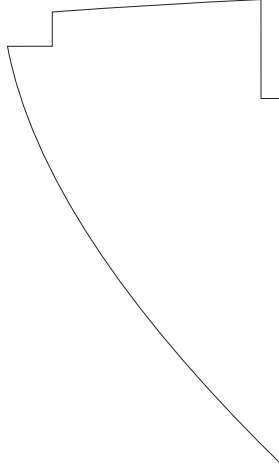
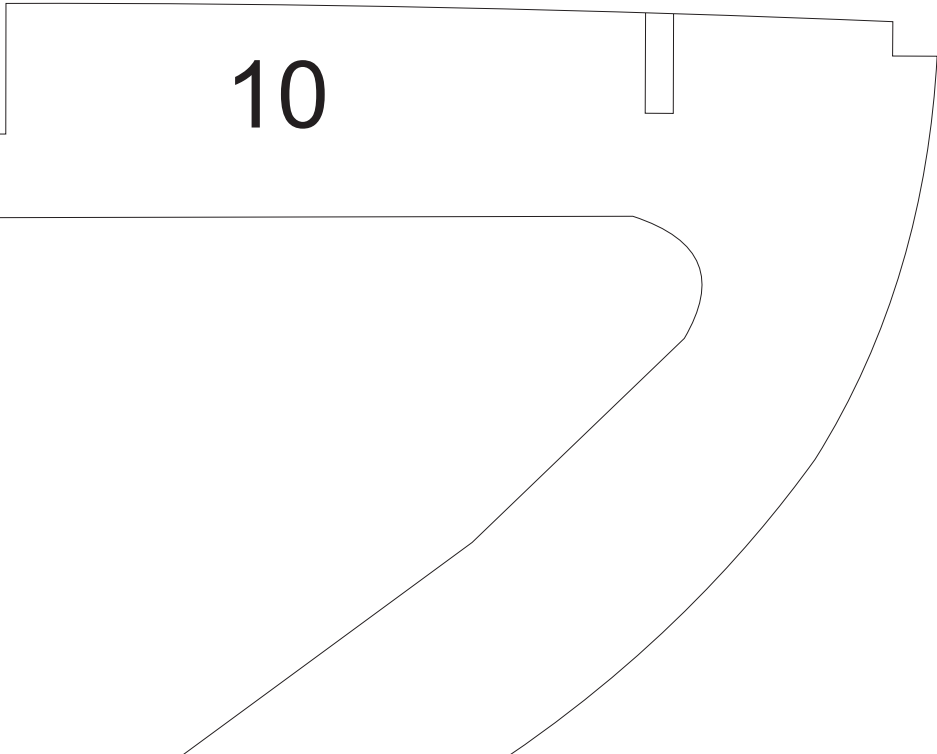

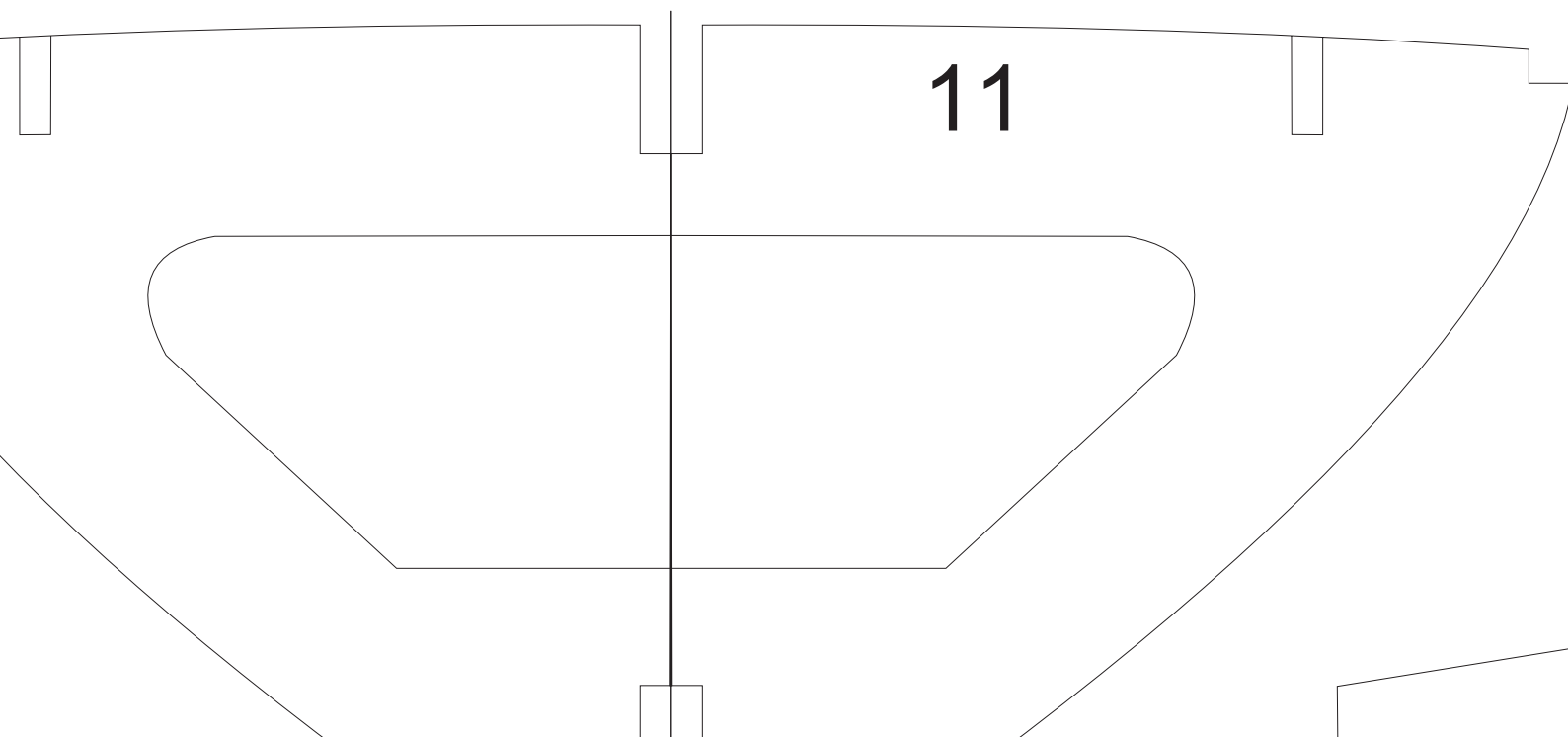
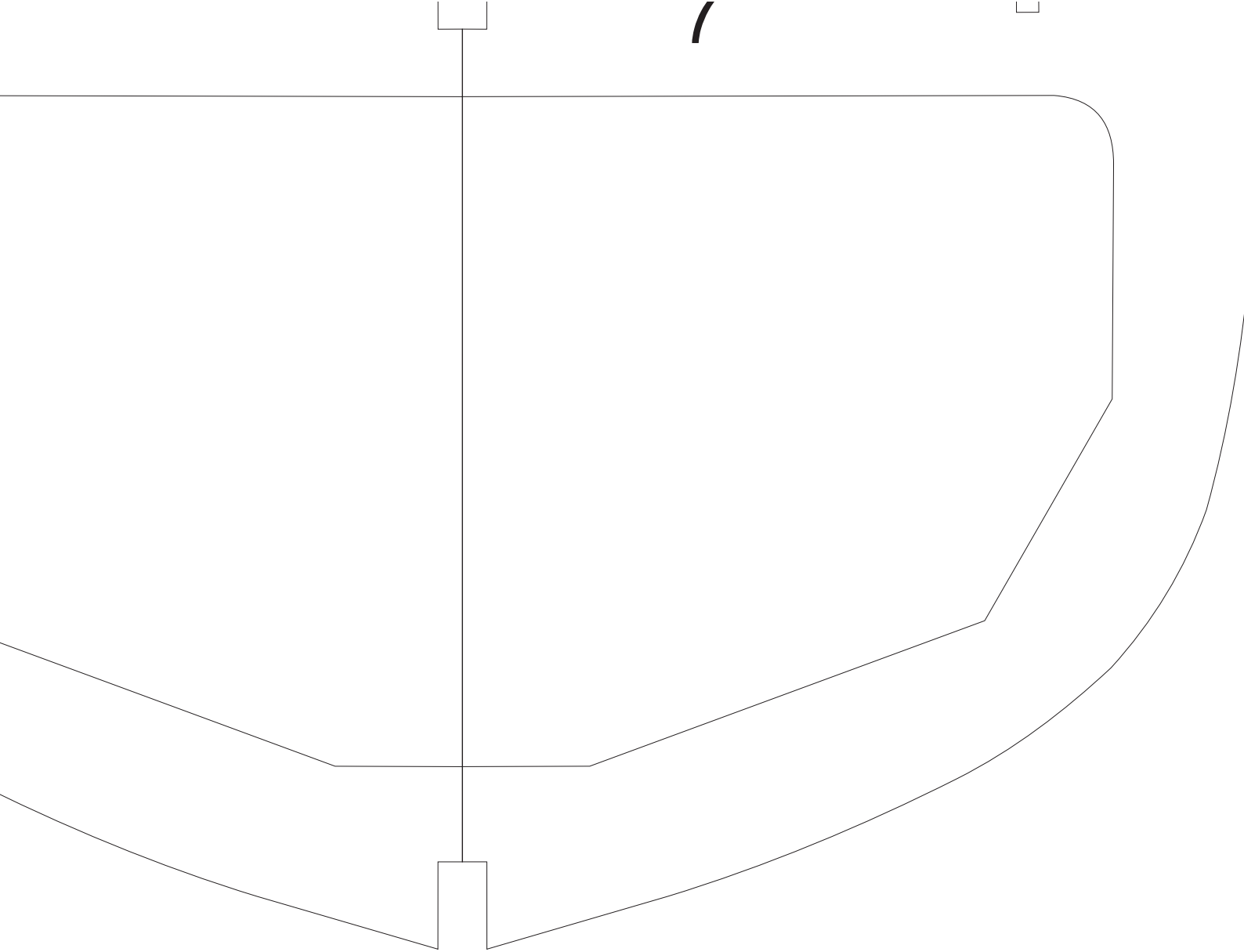

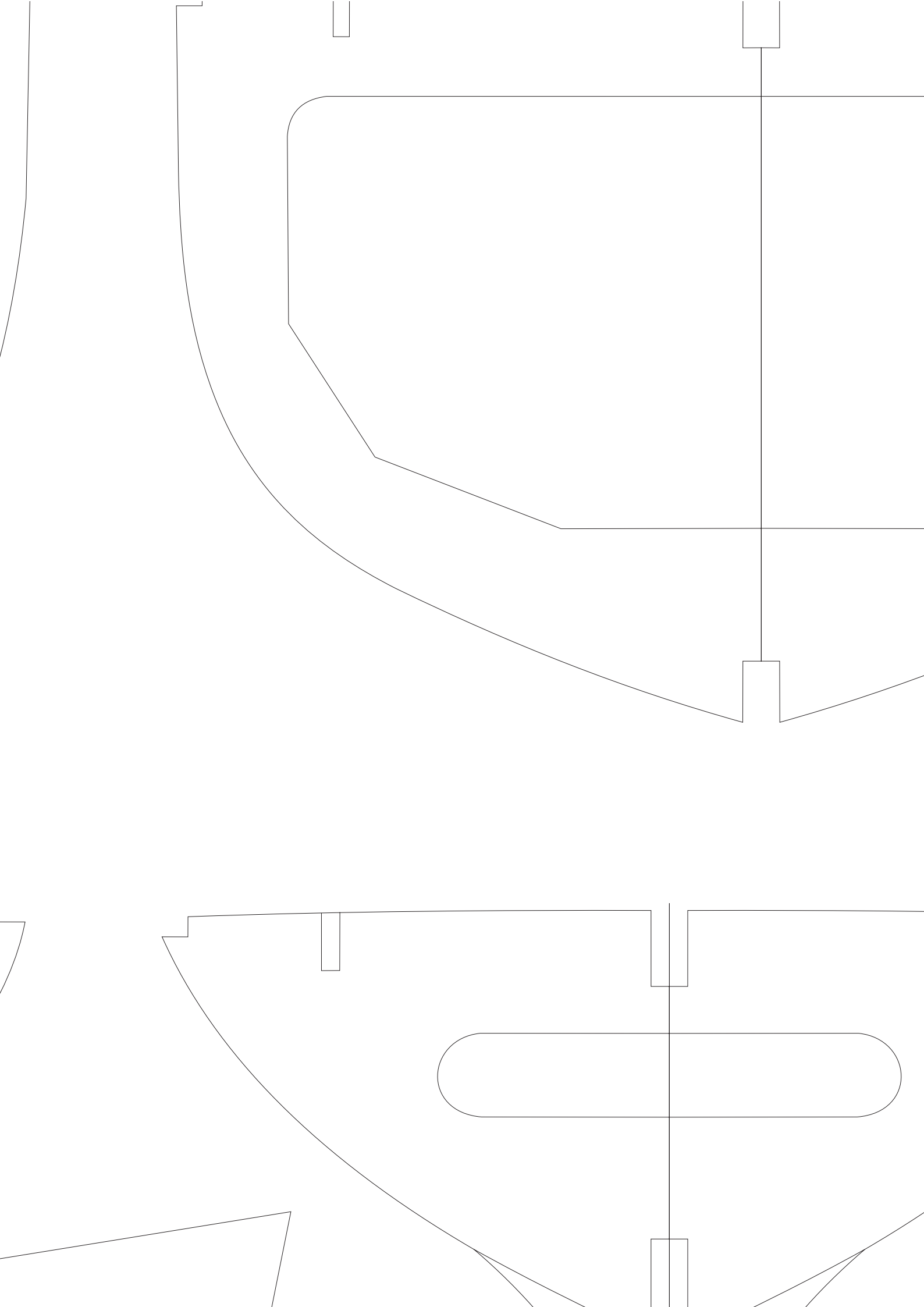

8

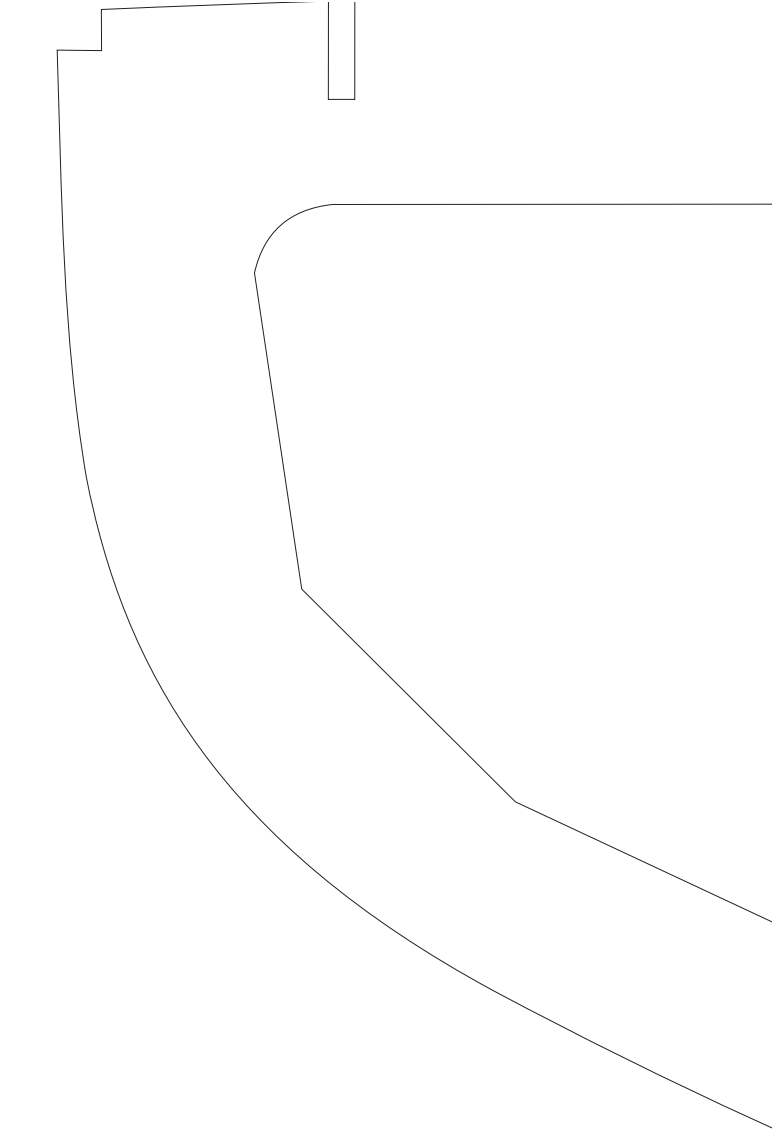
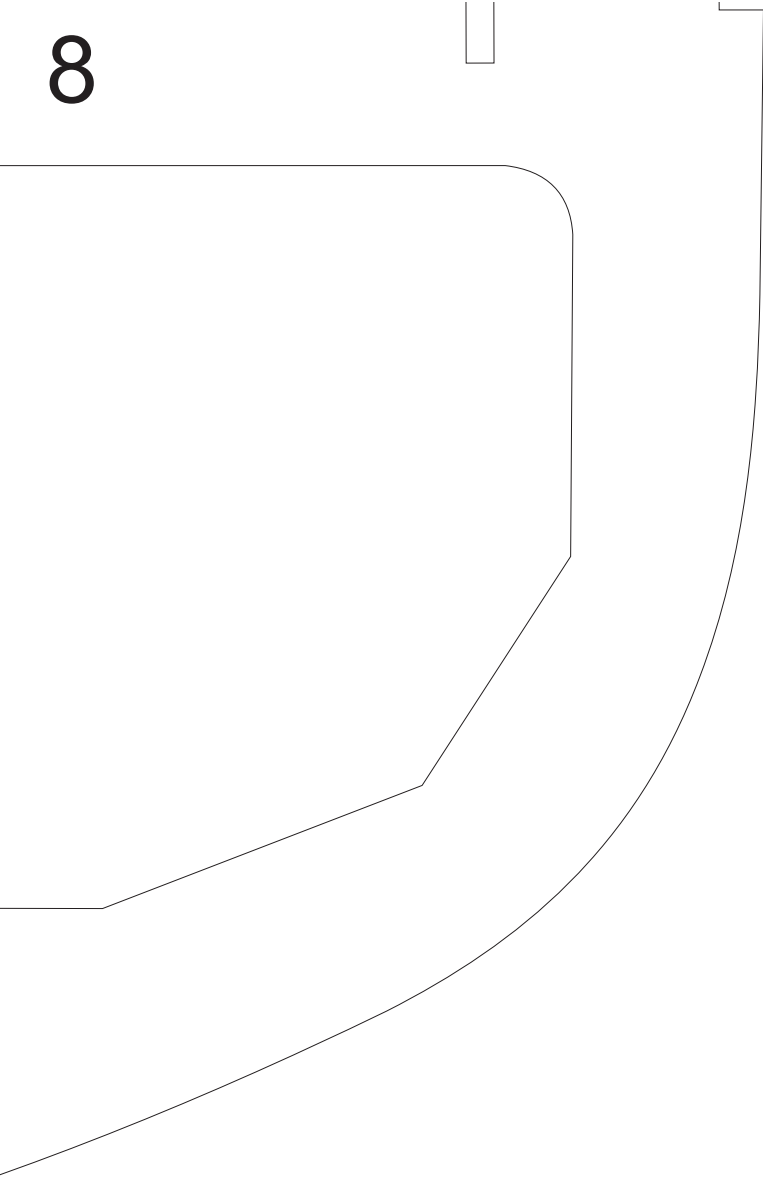

12

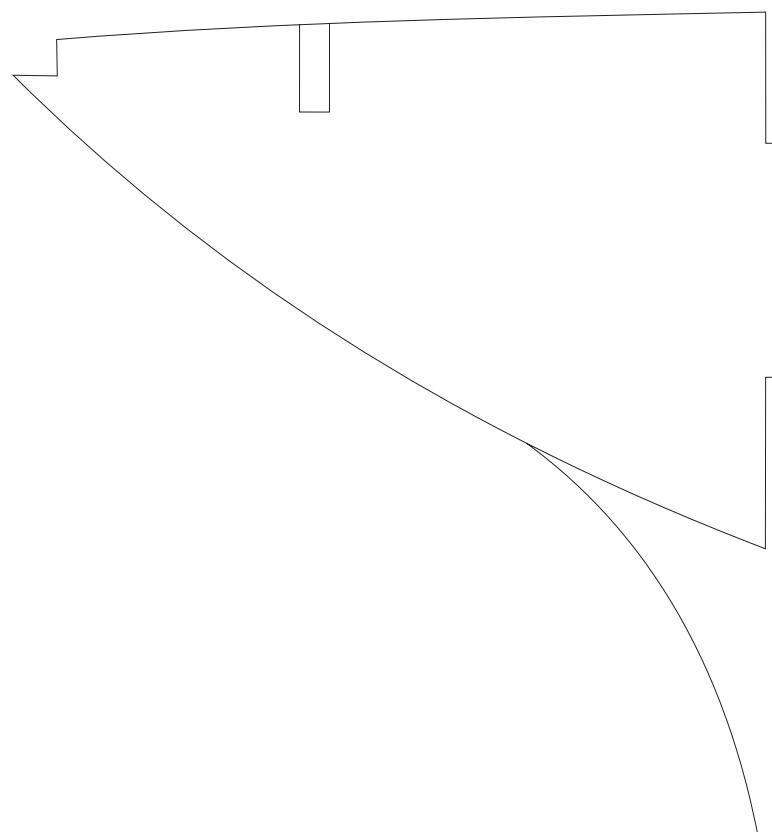
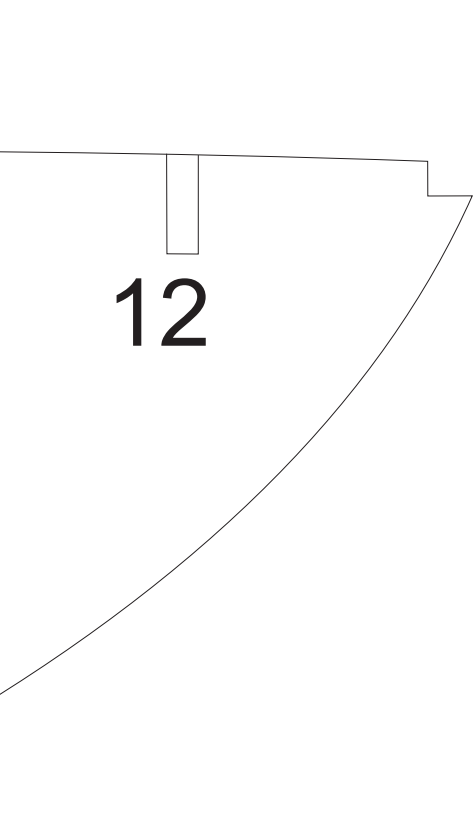

9

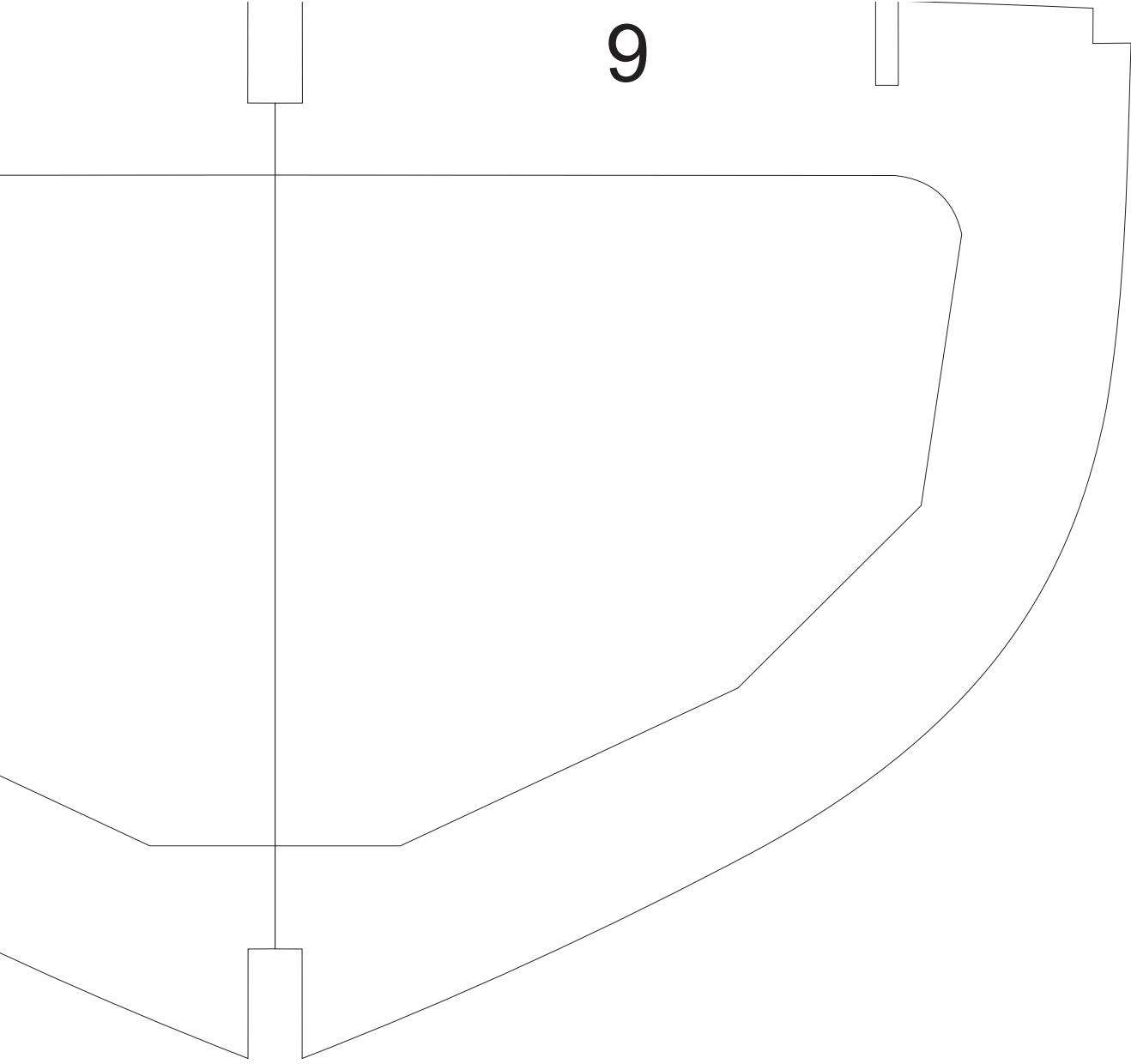

13

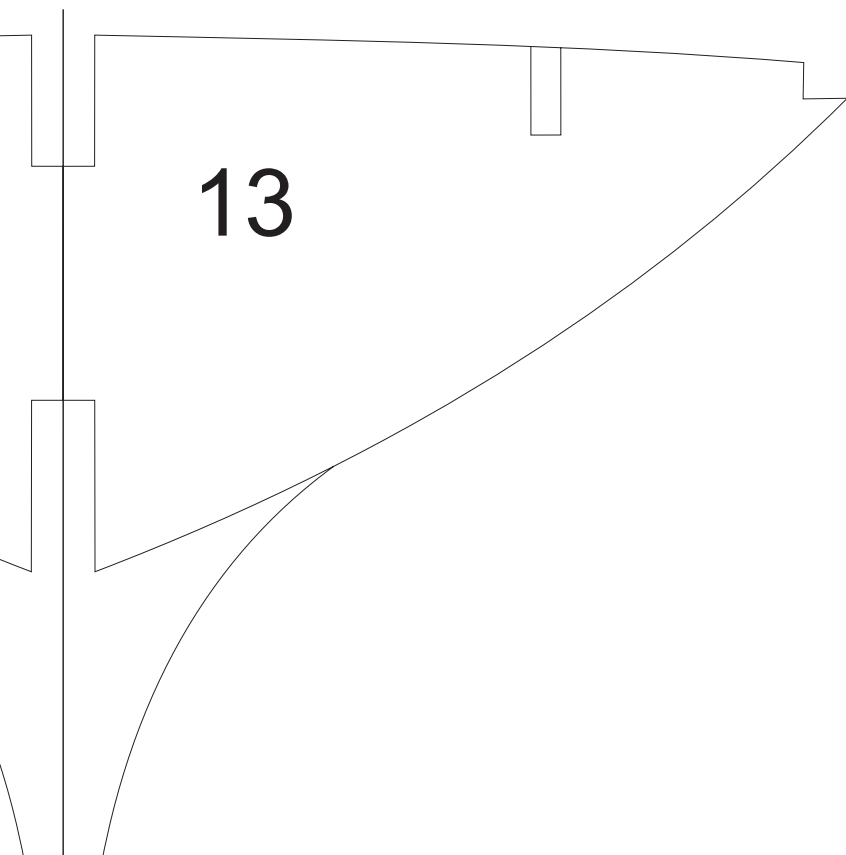

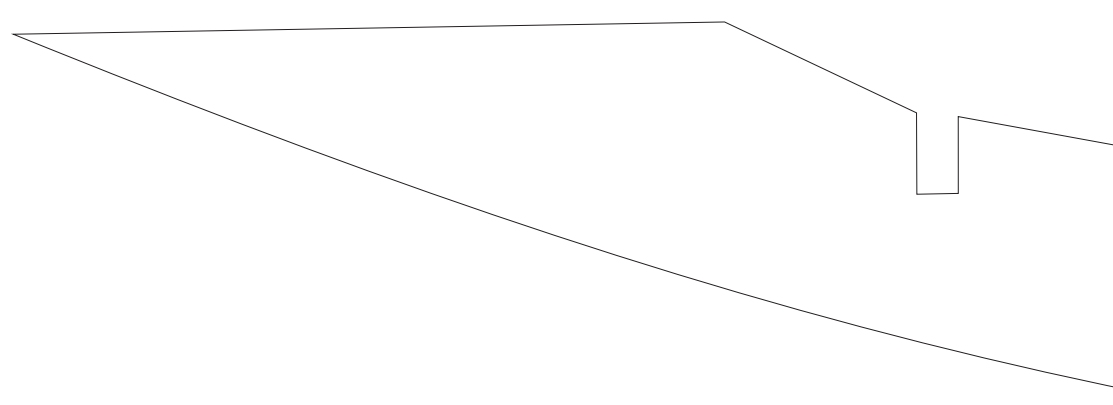
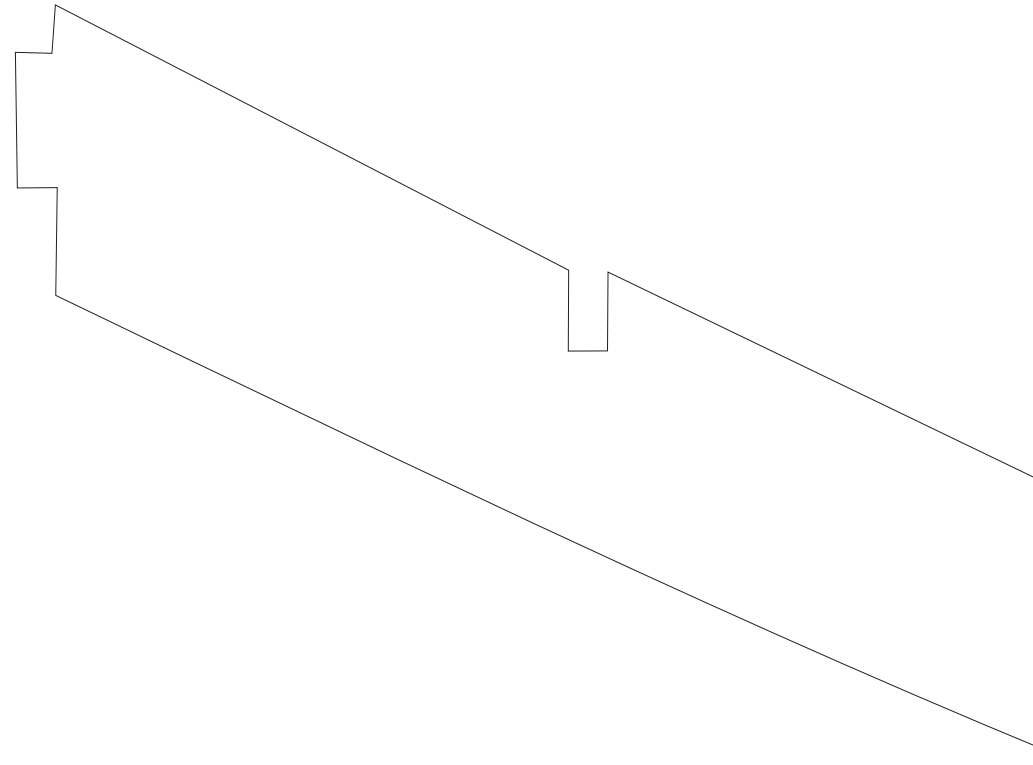
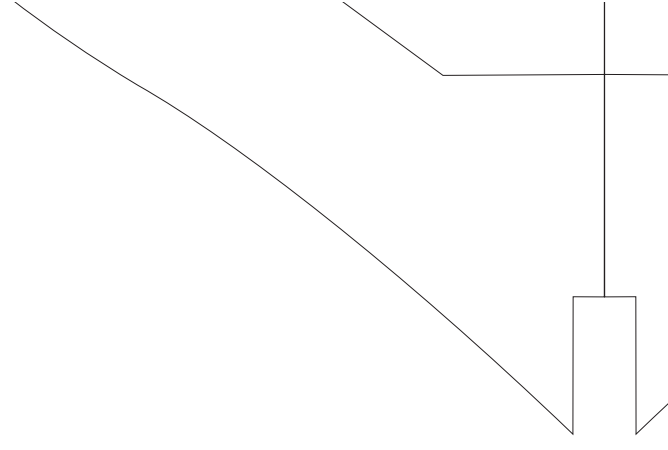

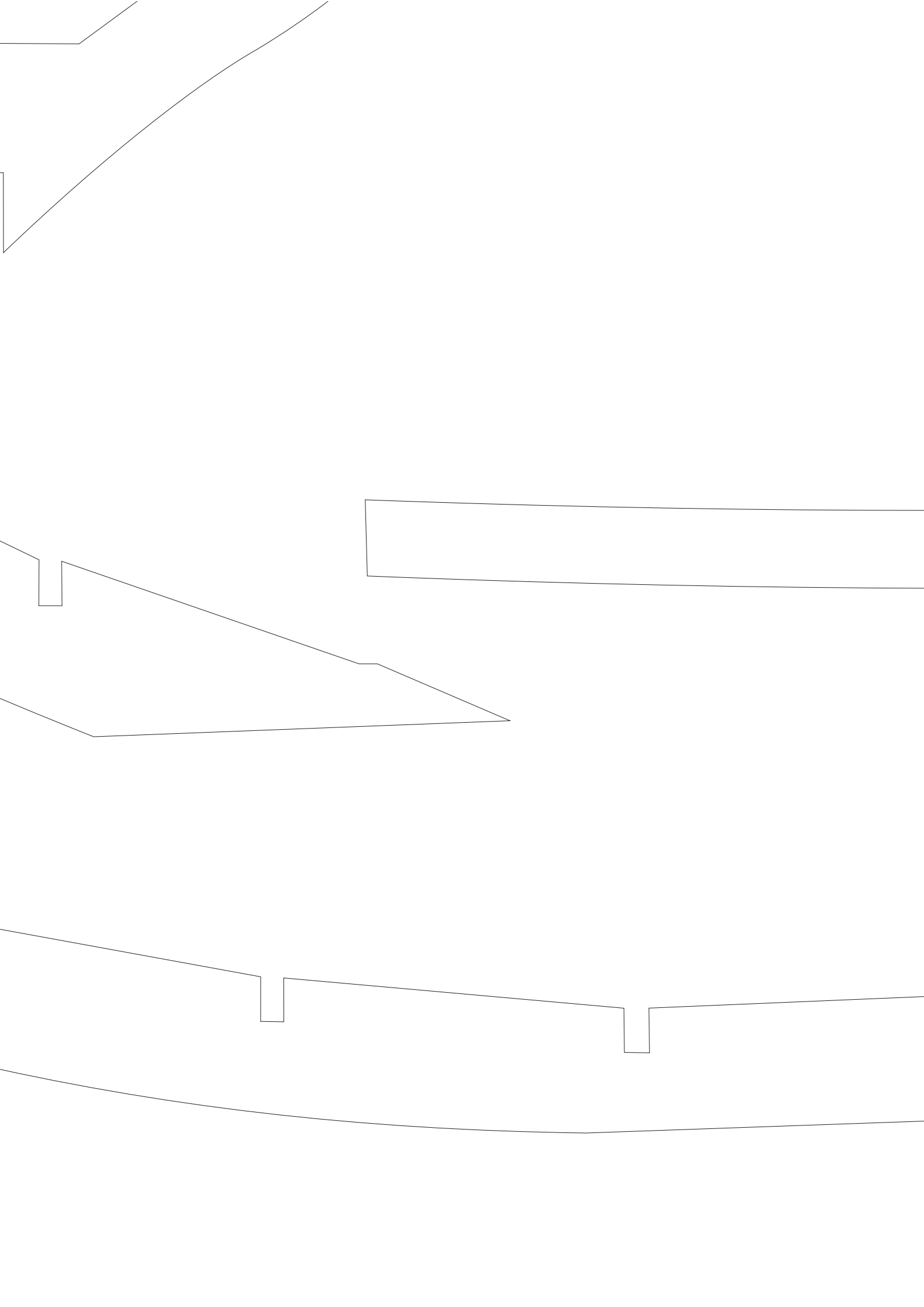

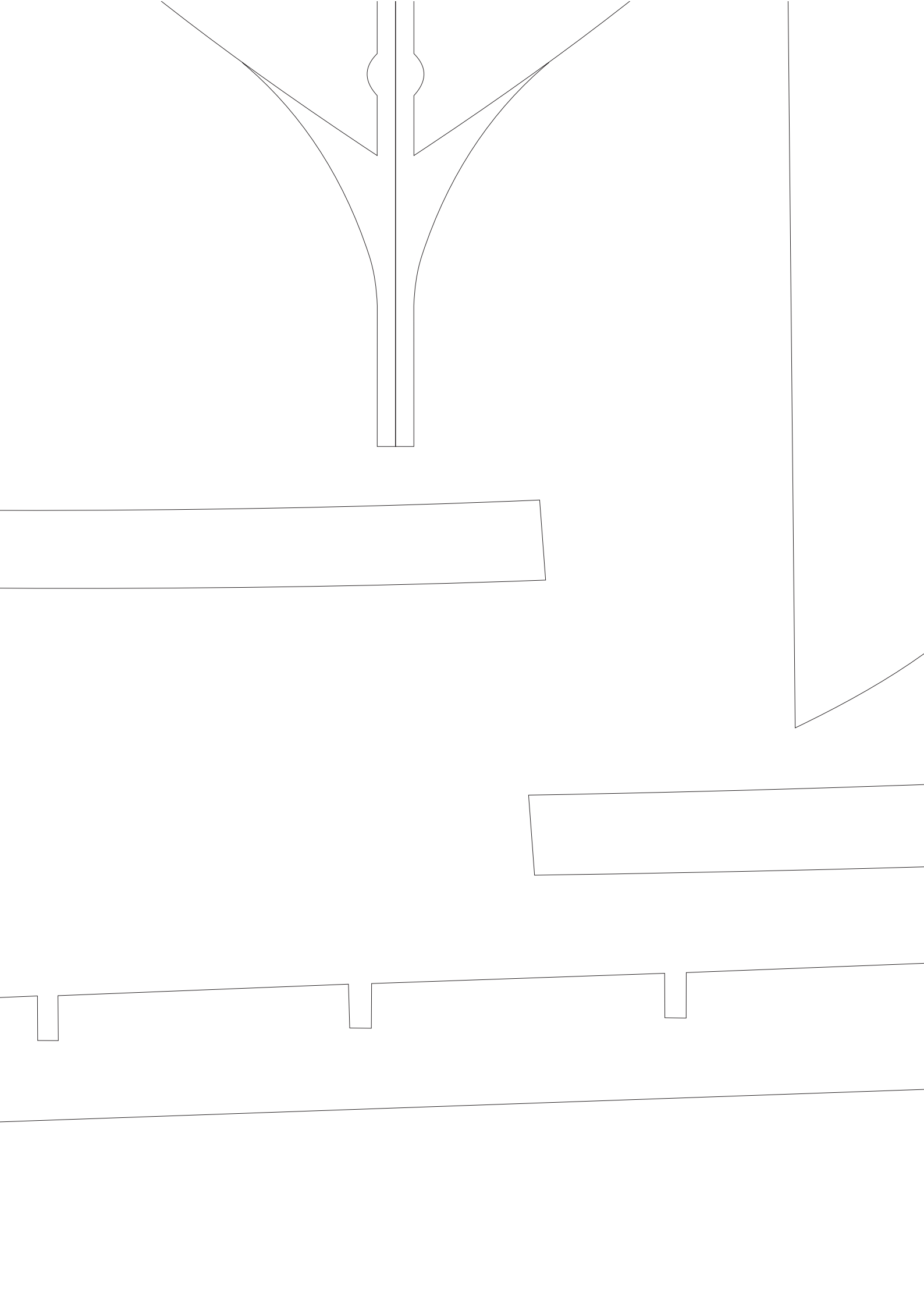



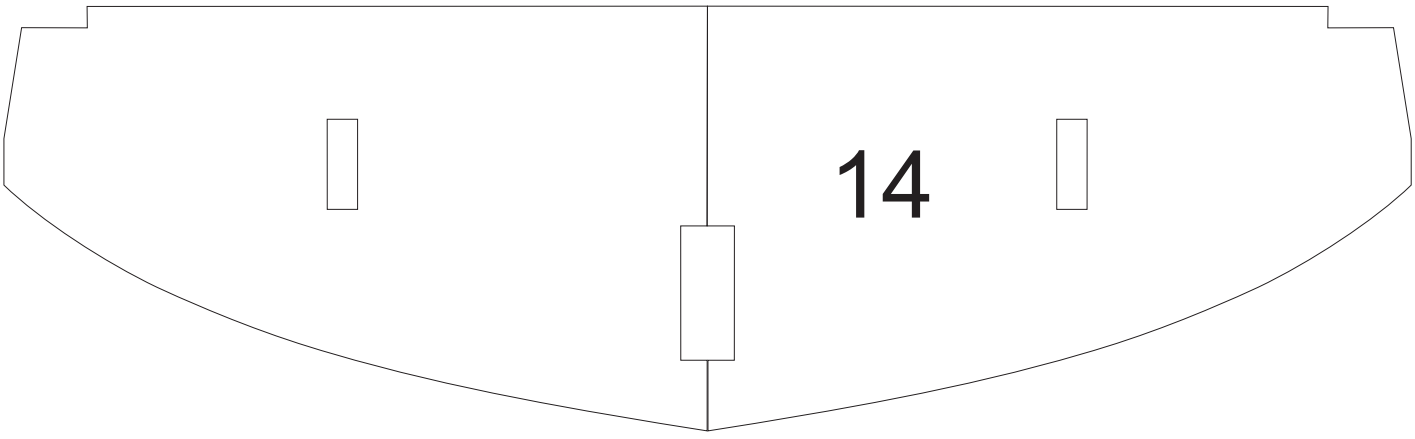

14

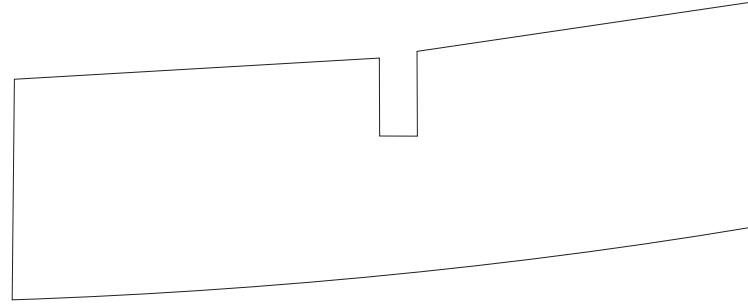
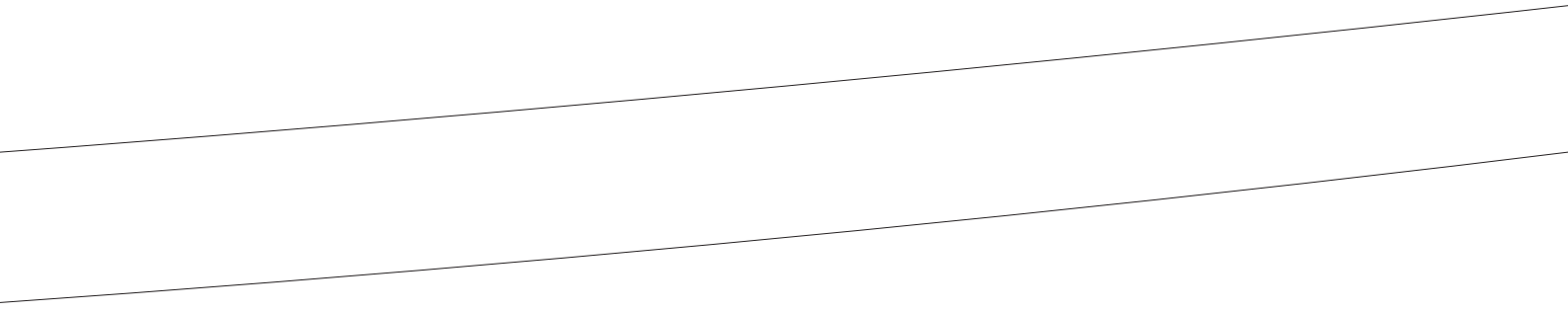

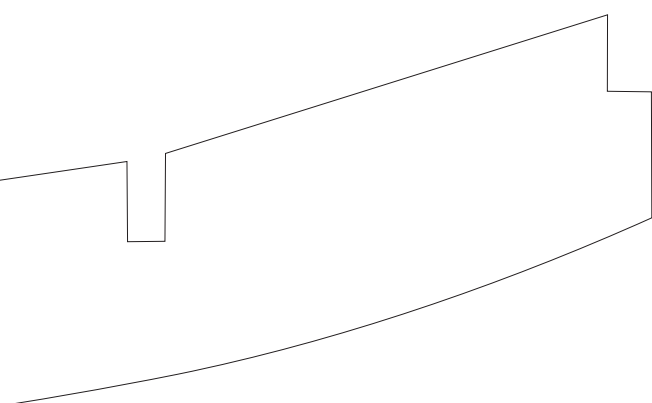
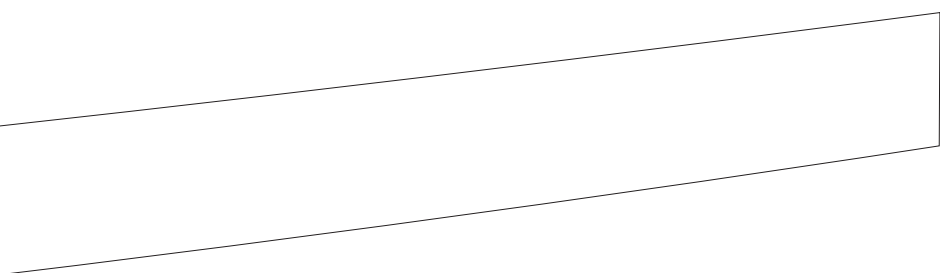
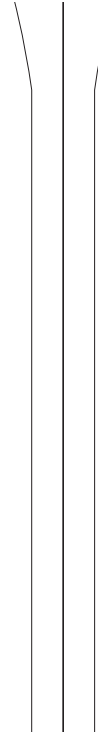

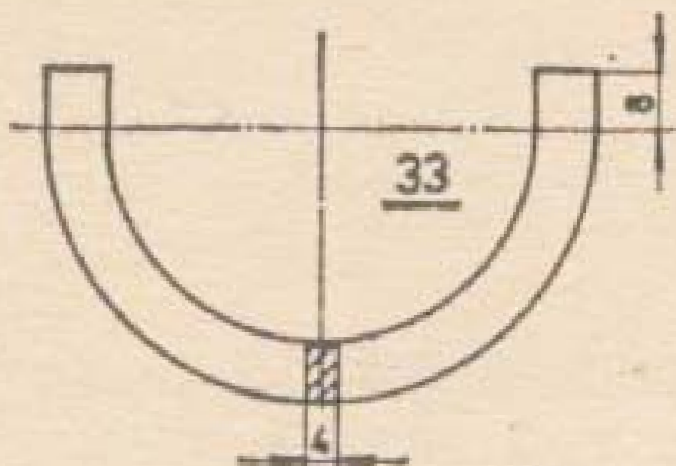

49

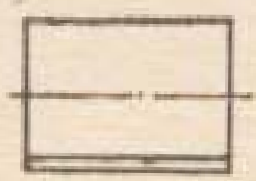

19

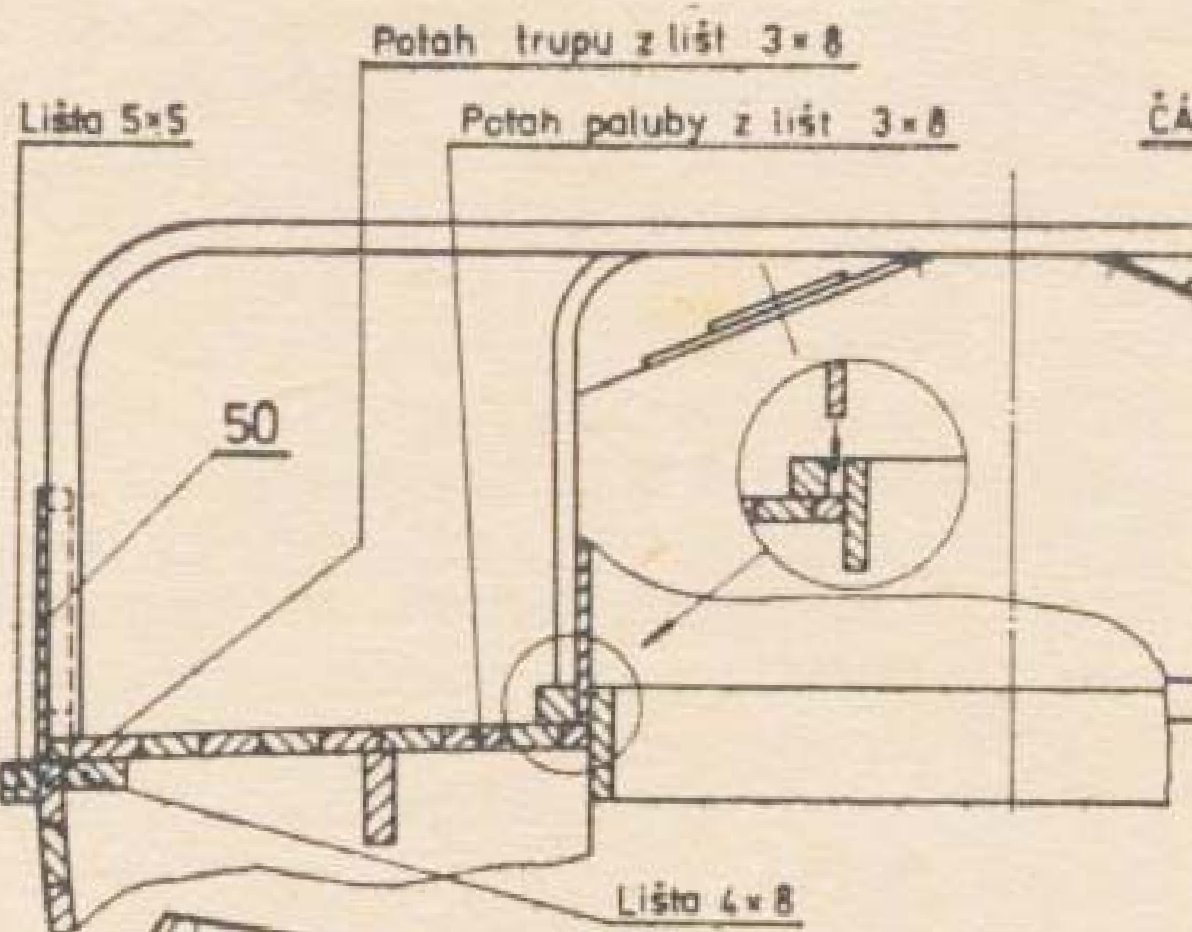
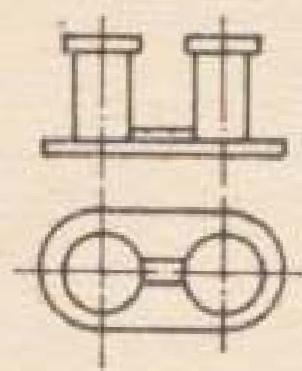
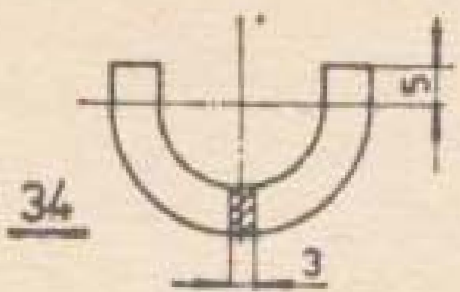

ČA

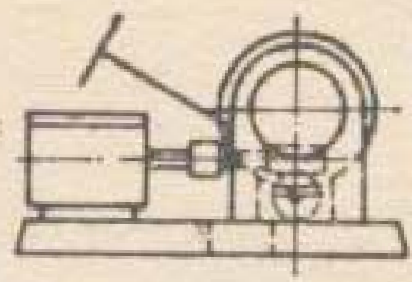

20

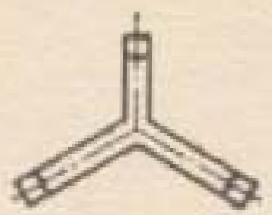
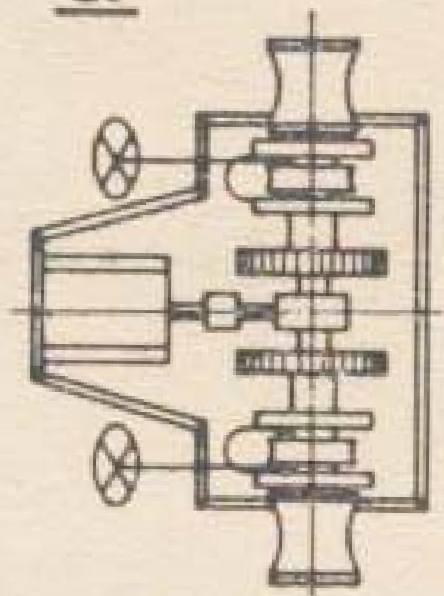

ČÁSTEČNÝ P

ČÁSTEČNÝ POHLED S

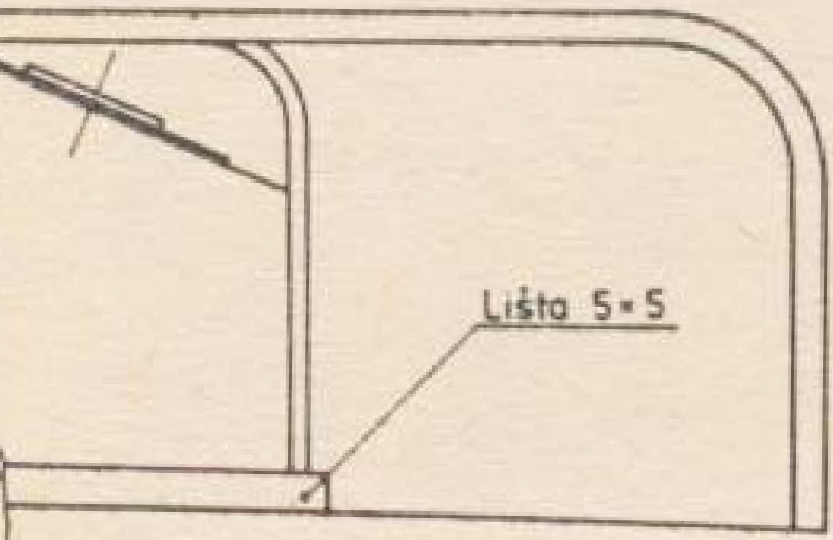

Lišta 5x5

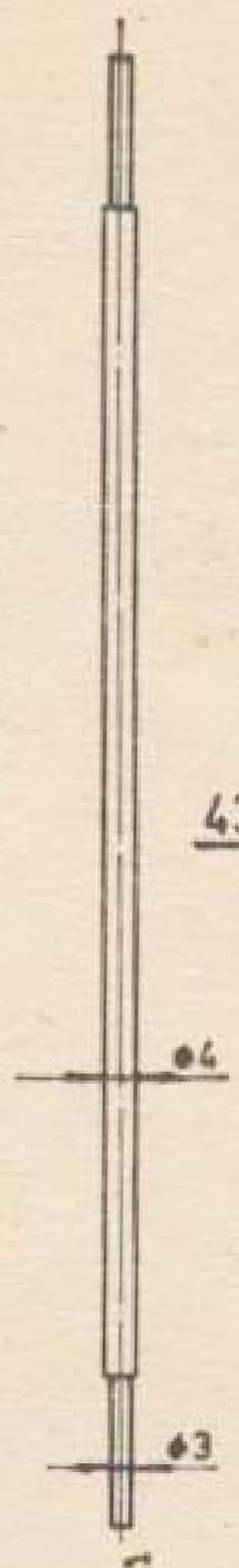

43

ø4

ø3

S →

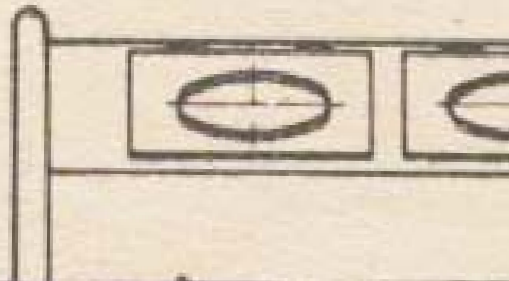

54

58

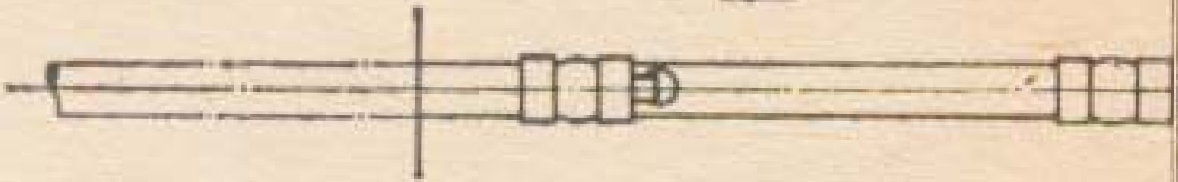

POHLED R

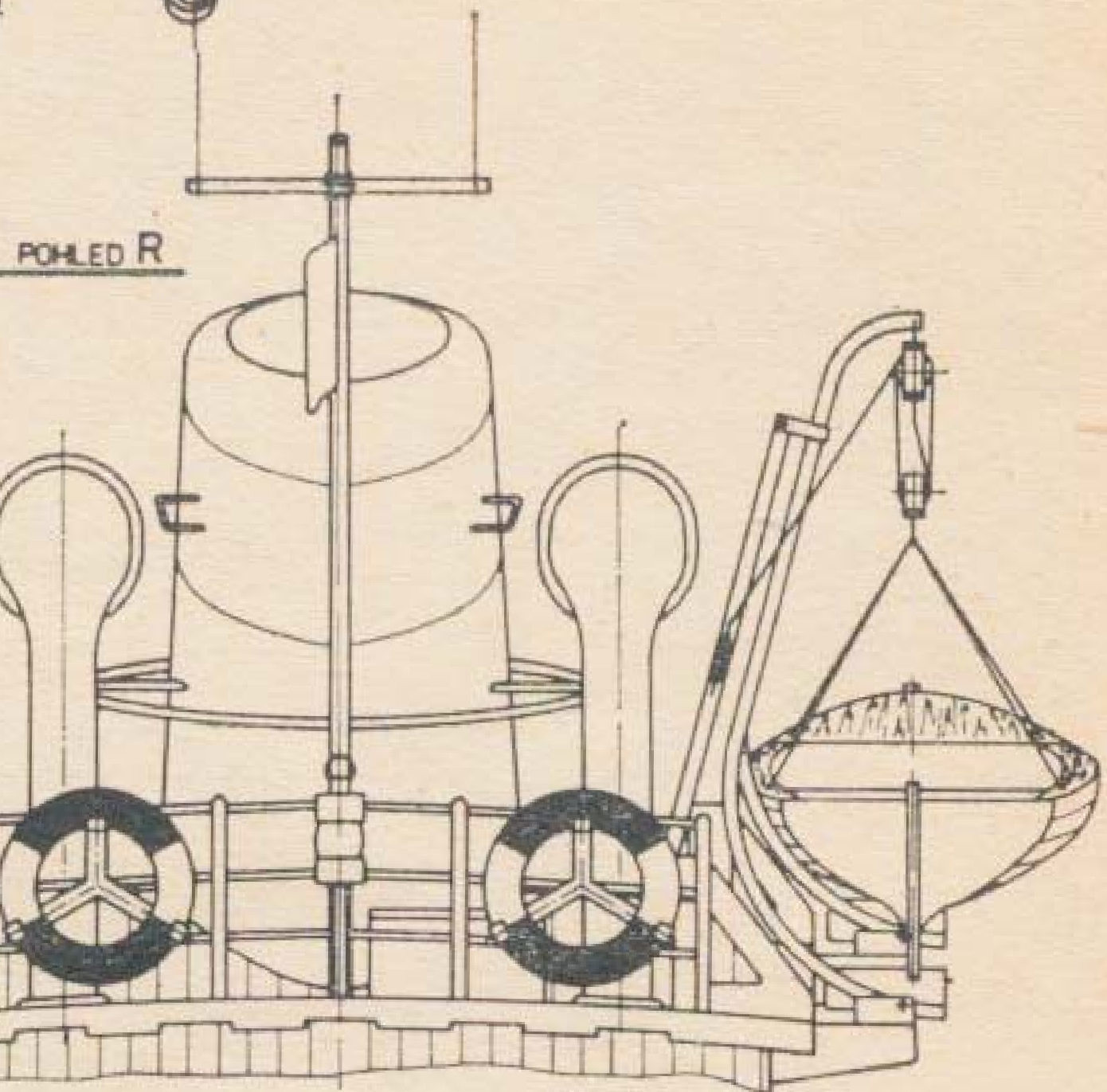

R

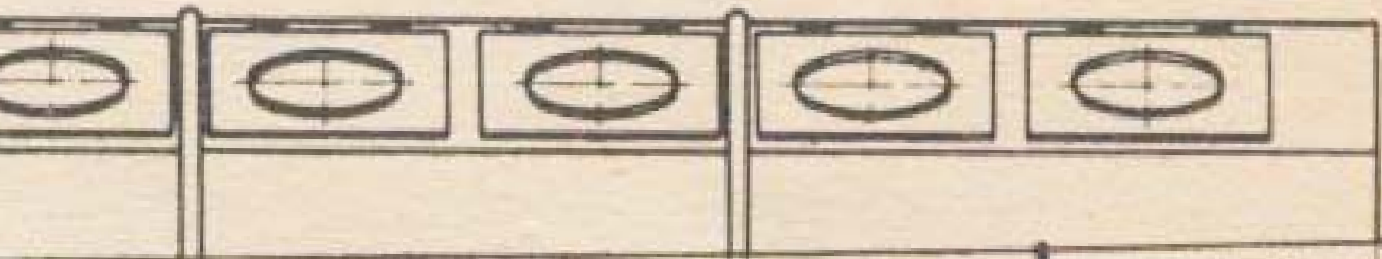

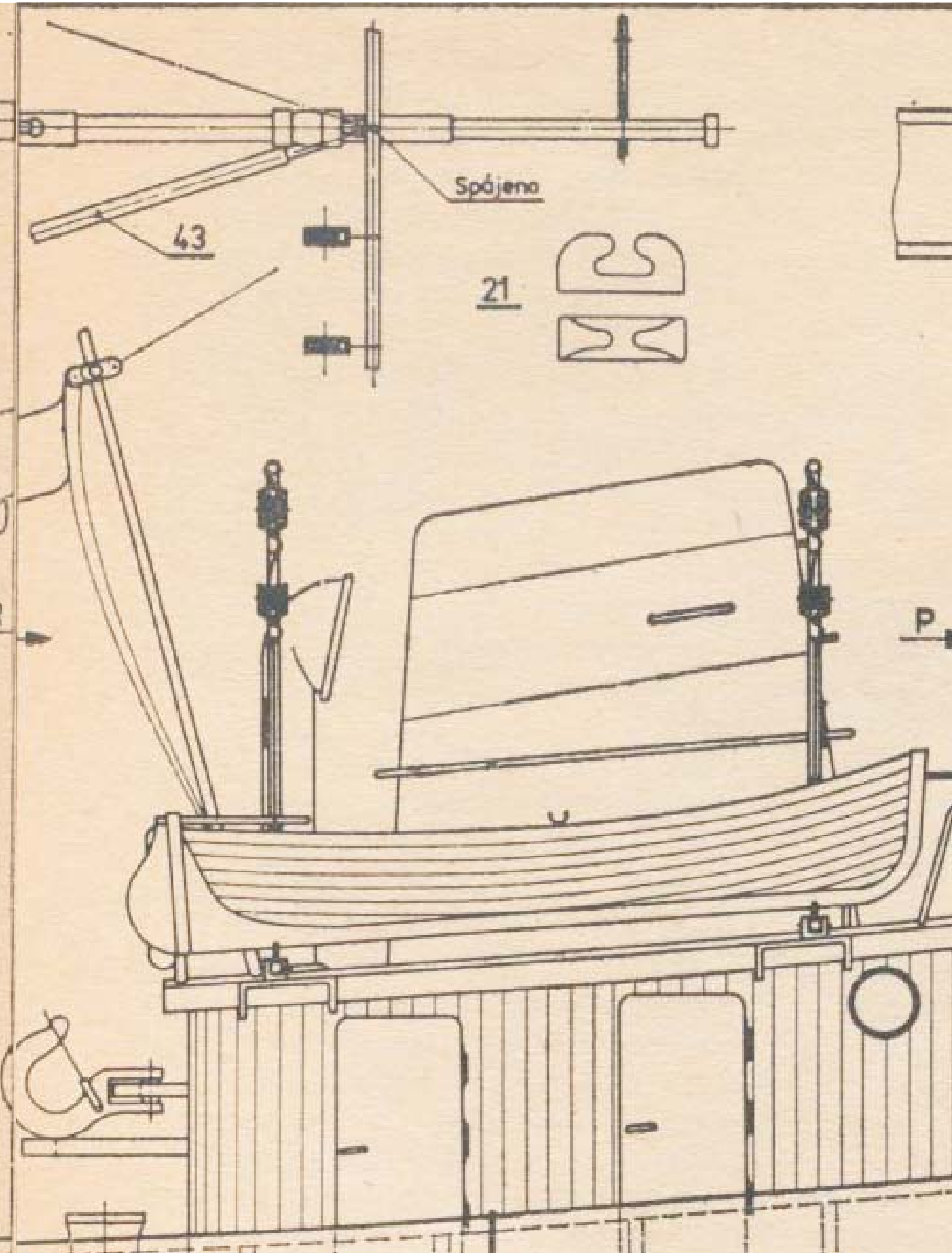

POHLED T

POHLED

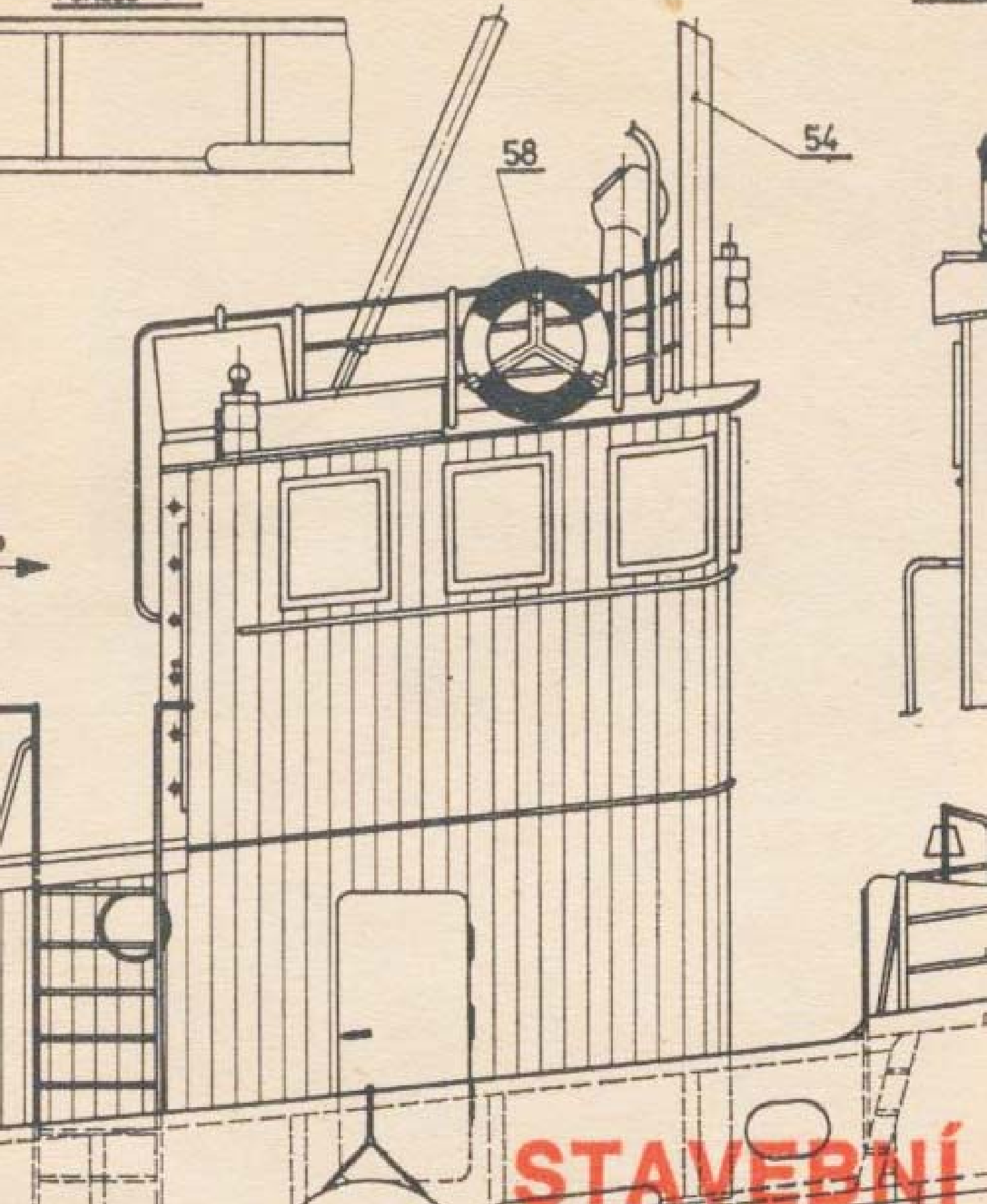

STAVEBNÍ

ED P

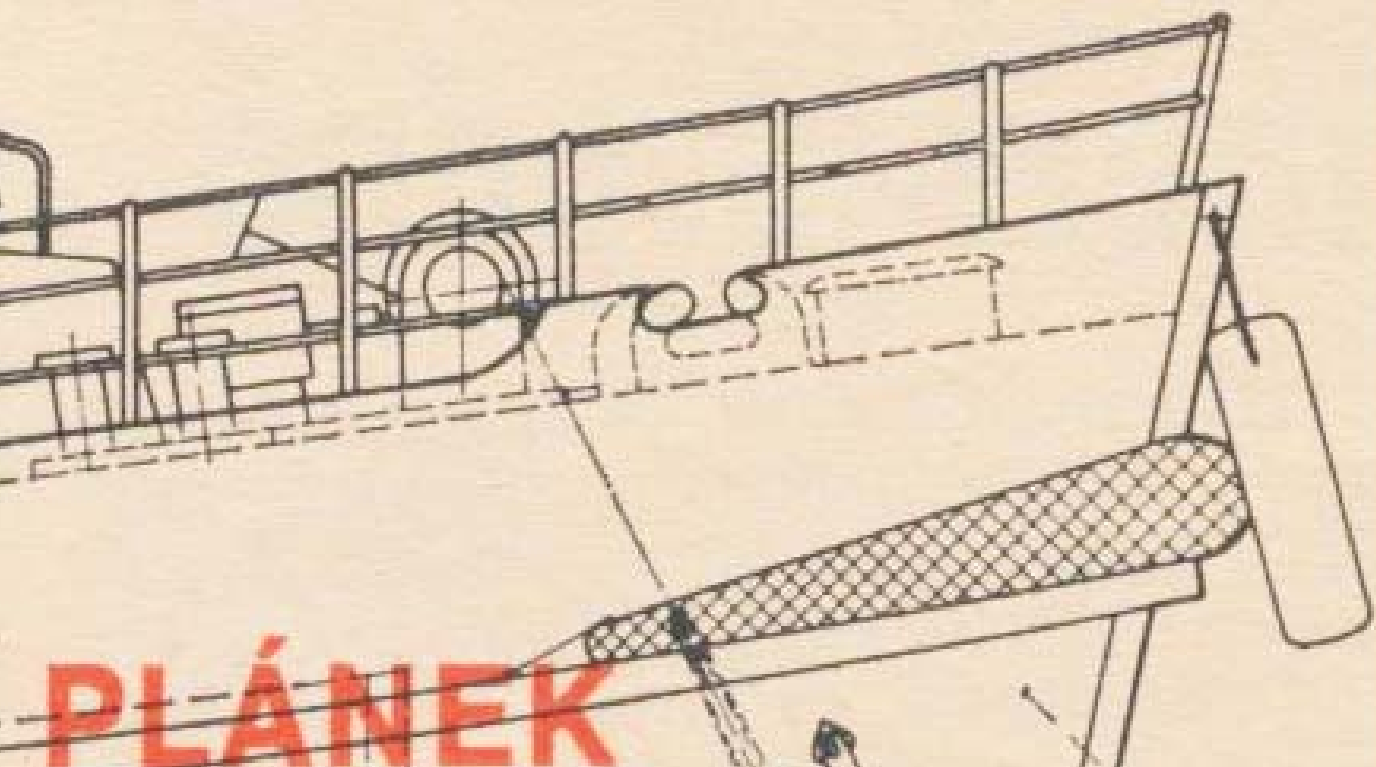
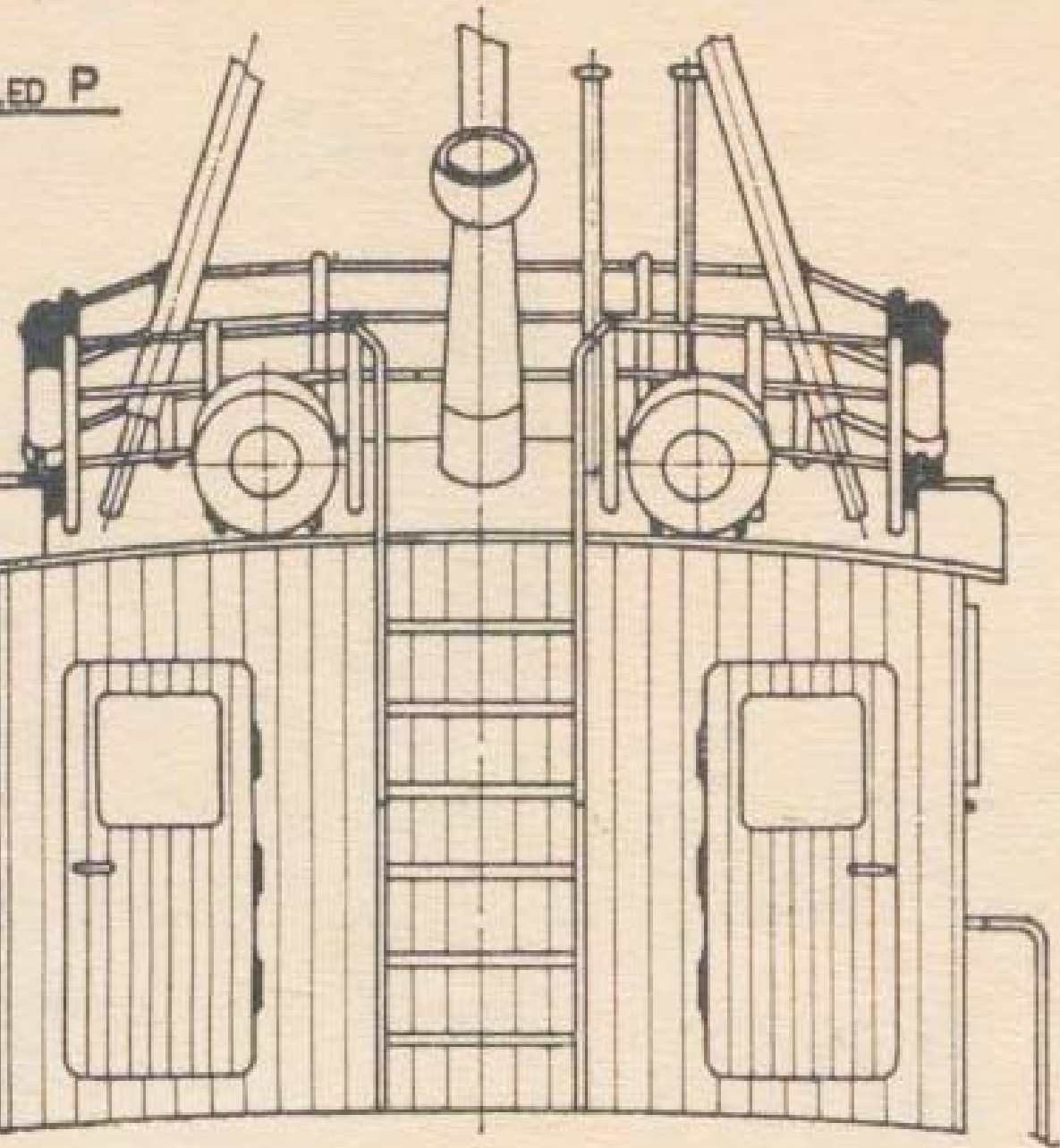

PLÁNEK

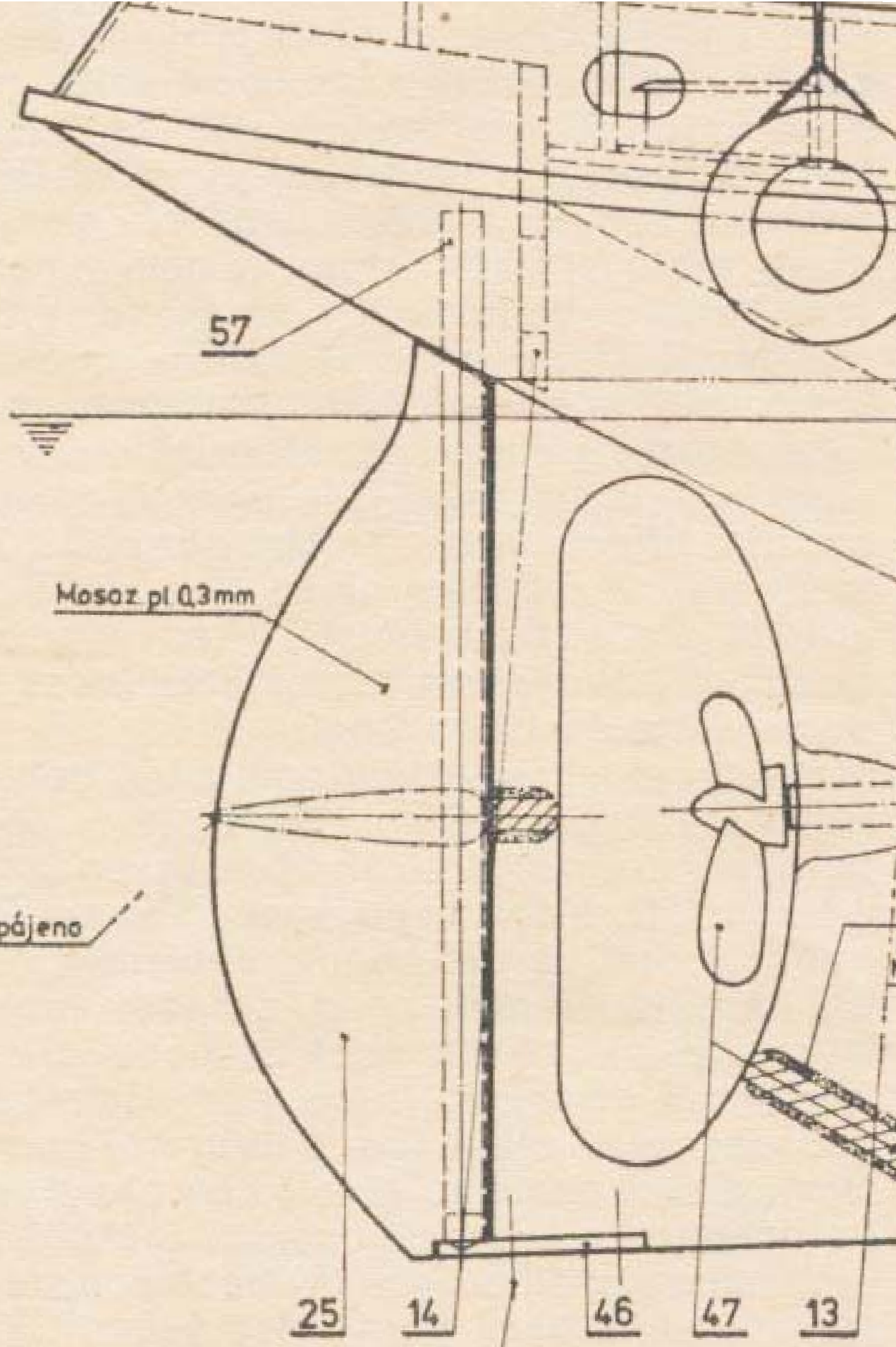

Šroub M3×12 - 2ks



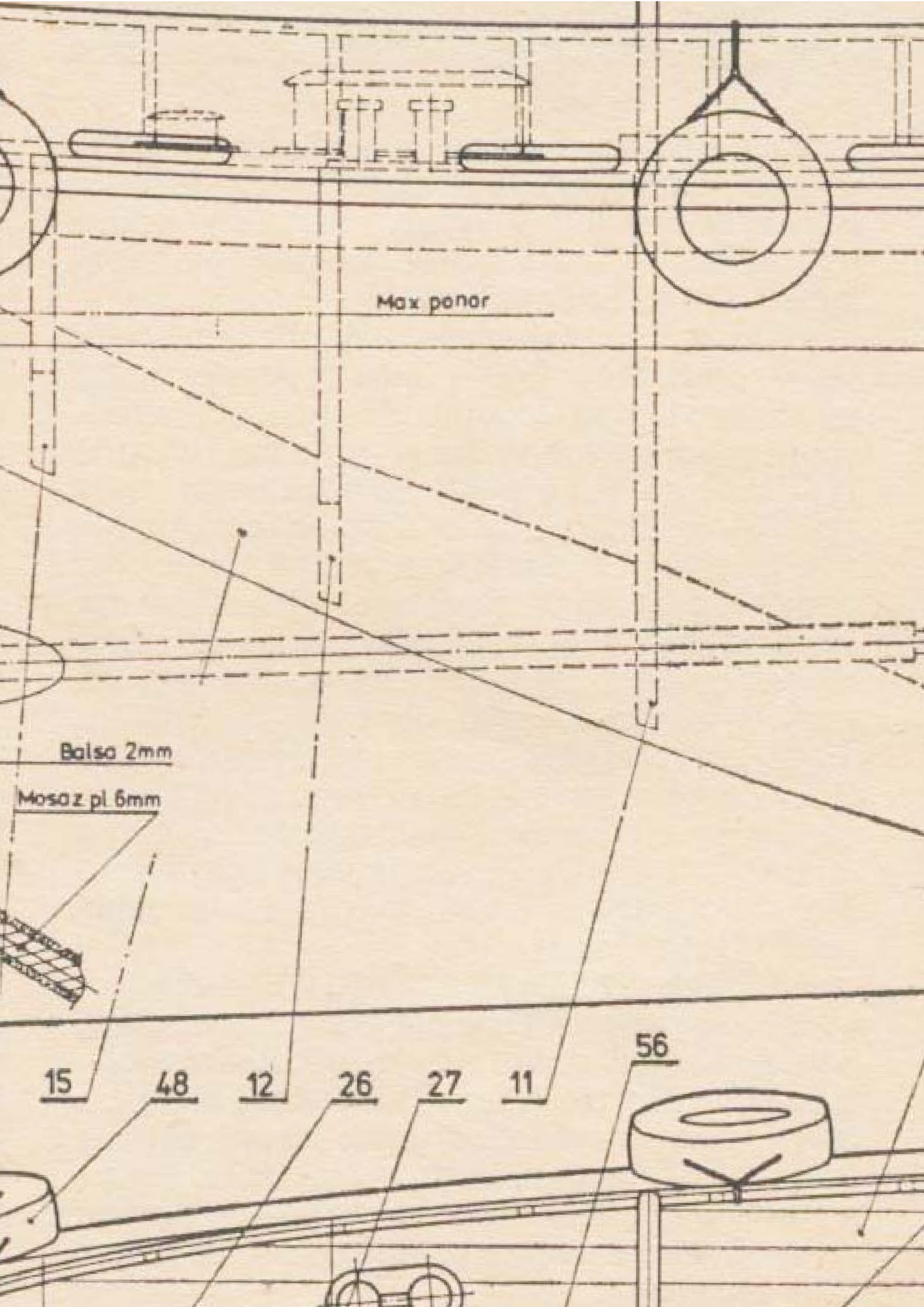

Max ponor

Balsa 2mm

Mosa z pl 6mm

15

48

12

26

27

11

56

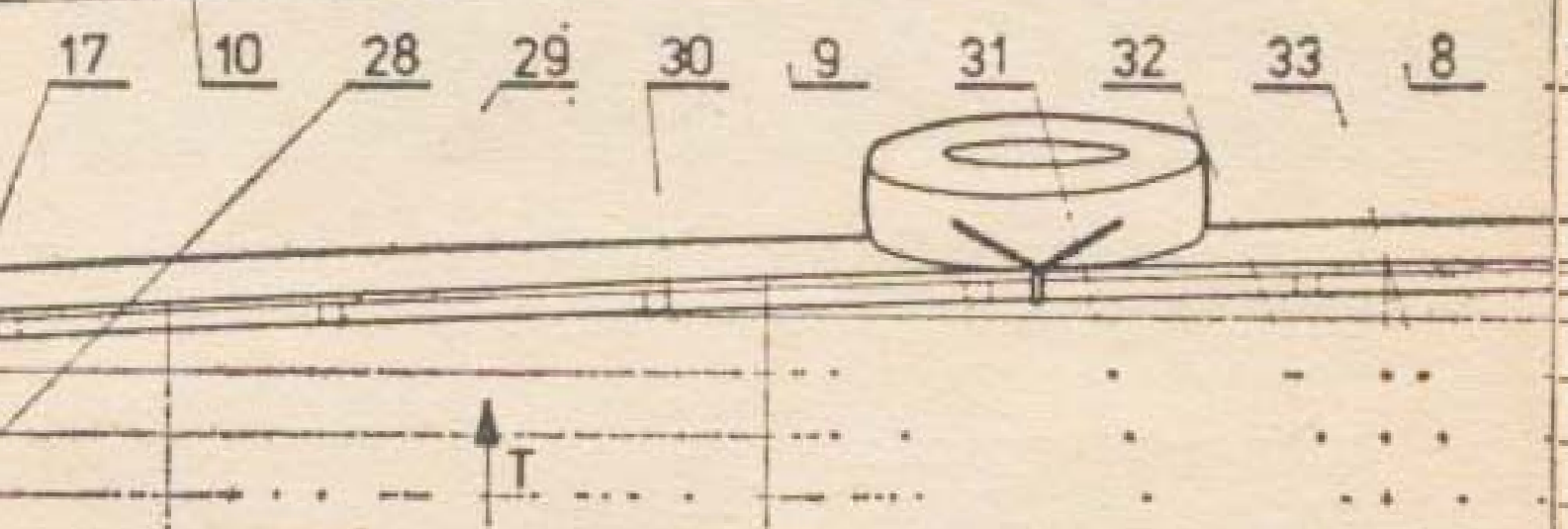
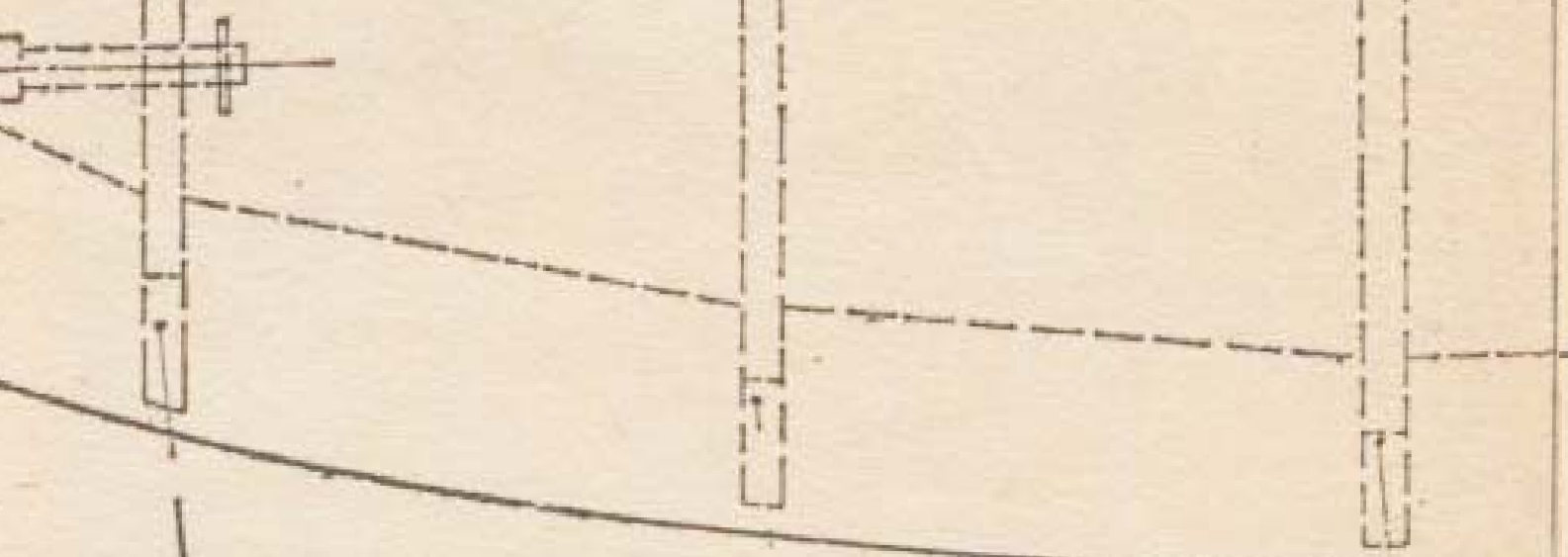
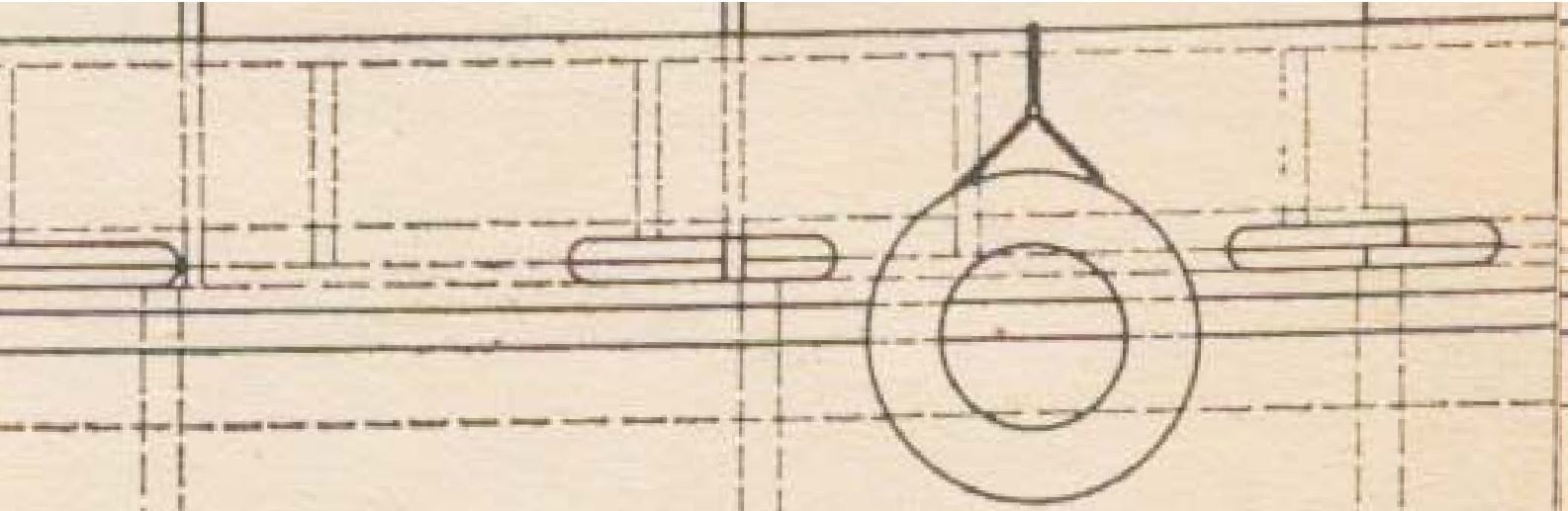

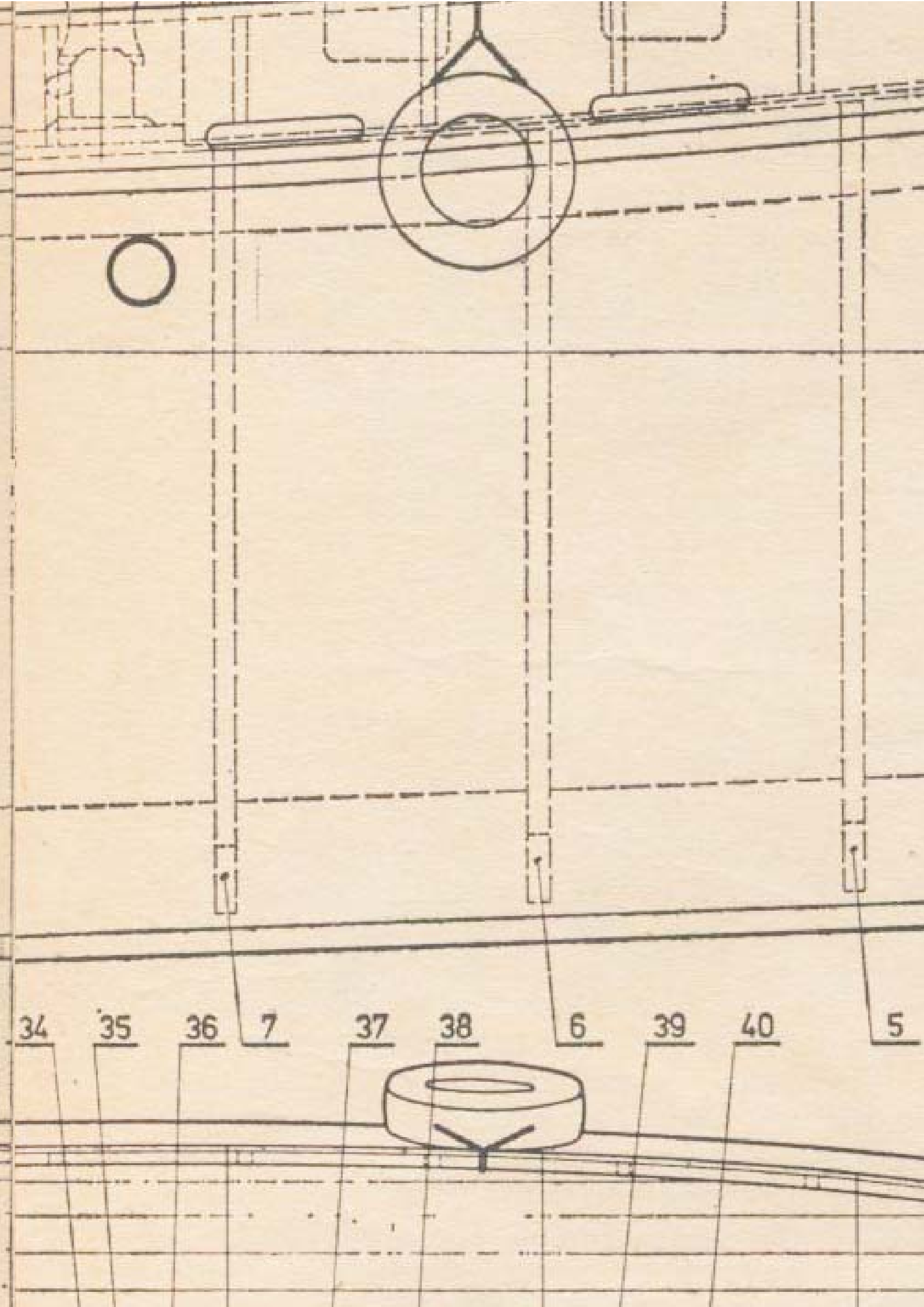

ve skutečné velikosti (máta A1) vyjde po
ve speciální řadě
Cena výtisku je 1
PAOLO-M přijde
ských prodejen as
1977, jeho vyjiti oz
sopise. Prosíme, a
dovoli plánek dříve
neurychlí, naopak

PLAN „**PAOLO-**
aeromodellers can
(scale 1:1) on edi
MODELÁŘ, Jung
110 00 Praha 1, CS

DEN BAUPLAN „
natürlicher Größe
nen die ausländis
bauer in der Reda
LÄß Jungmannov

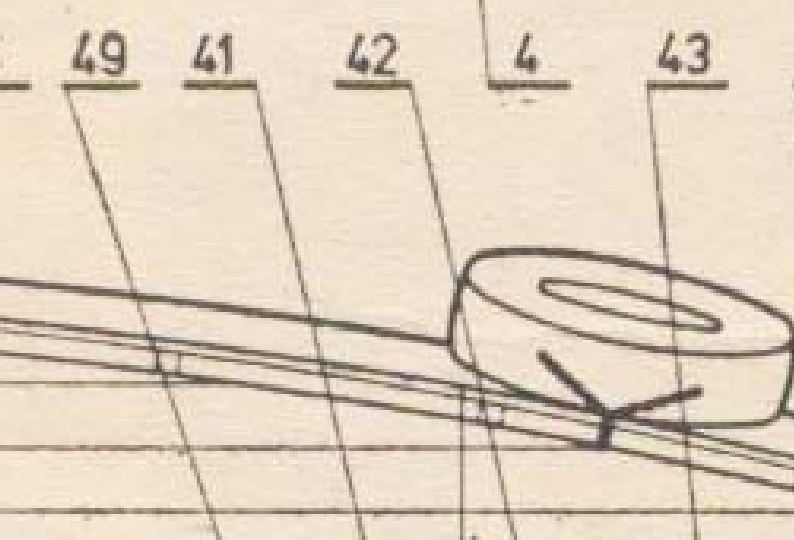
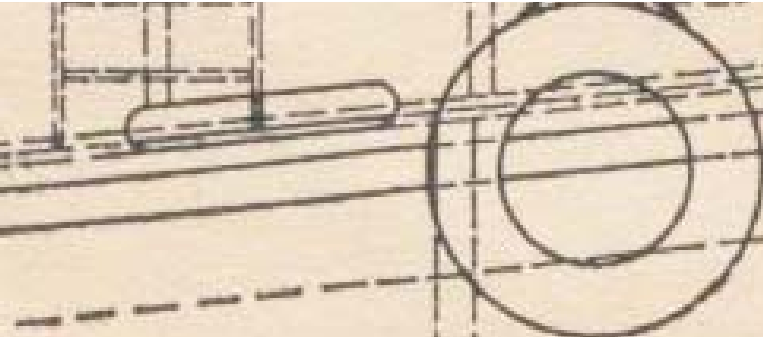

PLÁNEK

osti (tři listy for-
od číslem 80 (s)
ě **MODELÁŘ.**

Vrut 2,5-16

12 Kčs. Plánek
do modelář-
si ve 2. čtvrtletí
oznámíme v ča-
abyste nevyža-
e, vydání se tím

-M“ Foreign
n order the plan
litor's address:
gmannova 24,
SSR

,**PAOLO-M**“ in
e (M 1:1) kön-
schen Modell-
laktion **MODE-**
ya 24 110.00

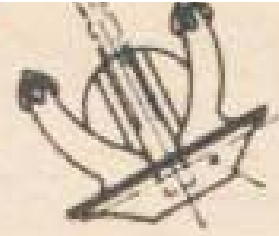

- 55
- 53
- 51
- 52

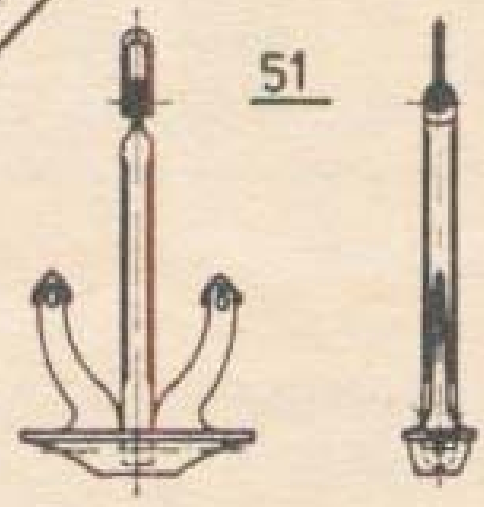

- 2
- 16
- 18
- 19
- 1
- 20
- 21
- 22
- 23

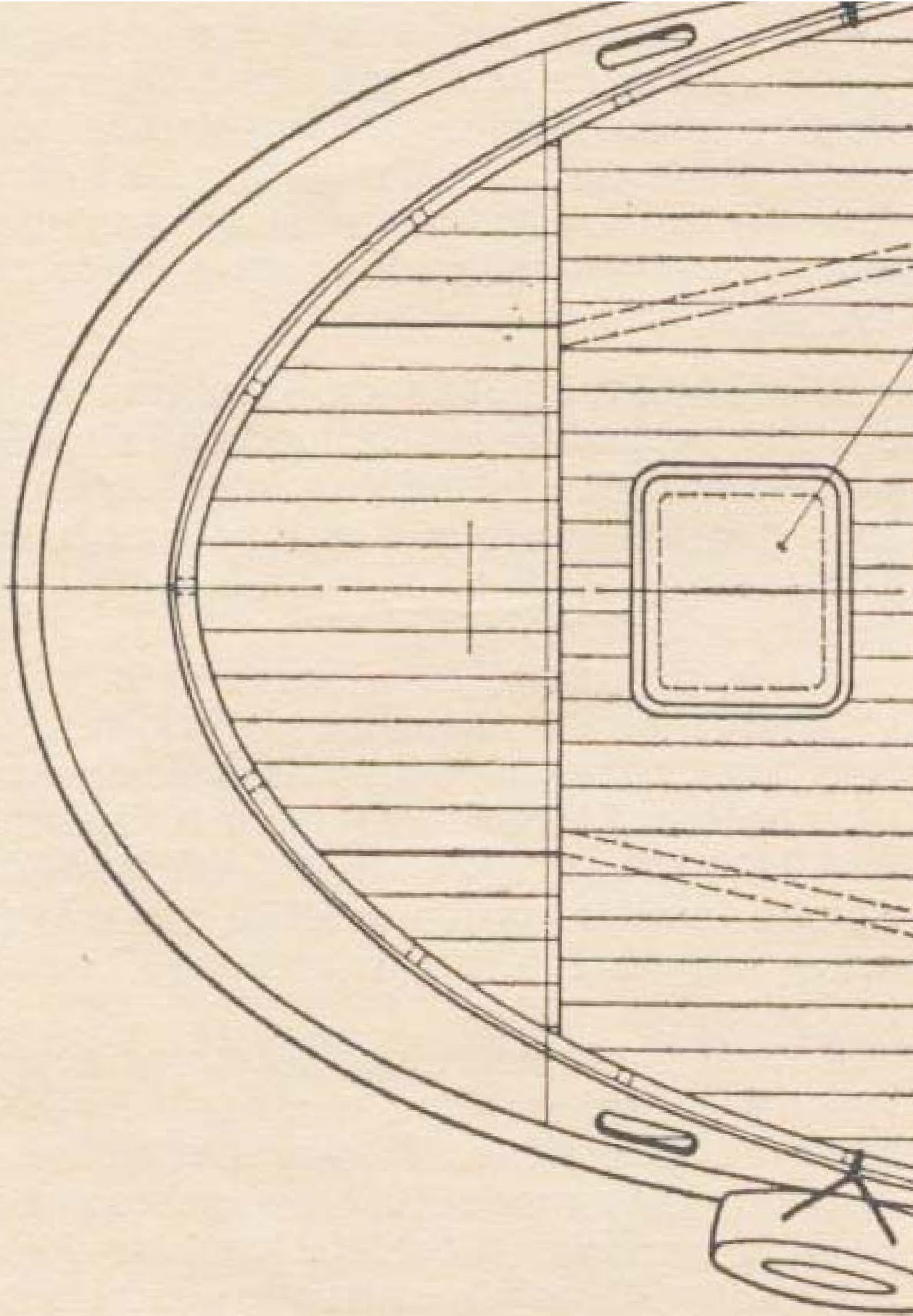

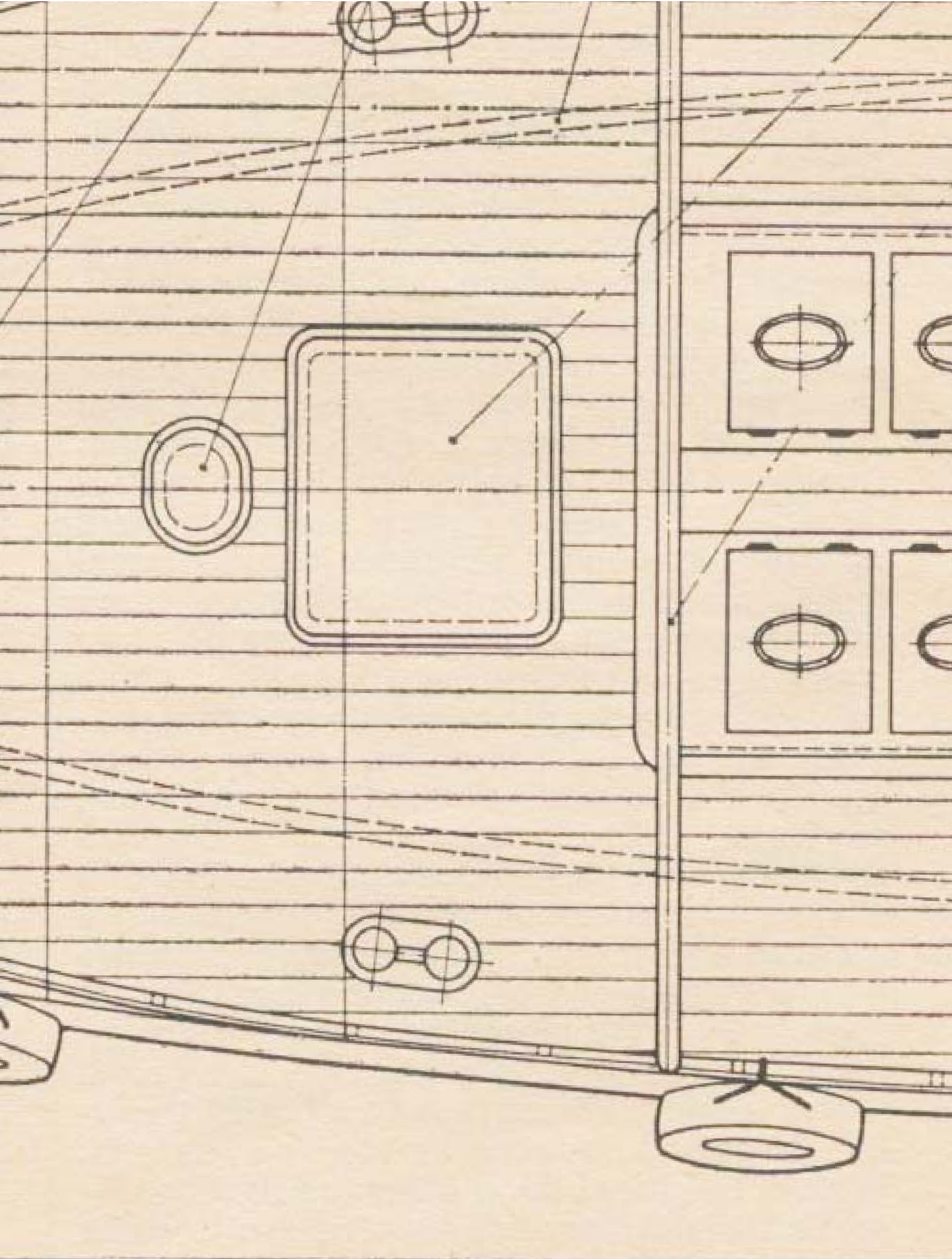

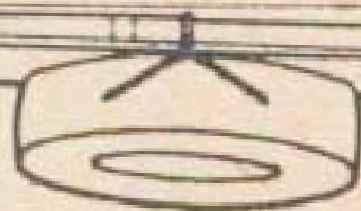
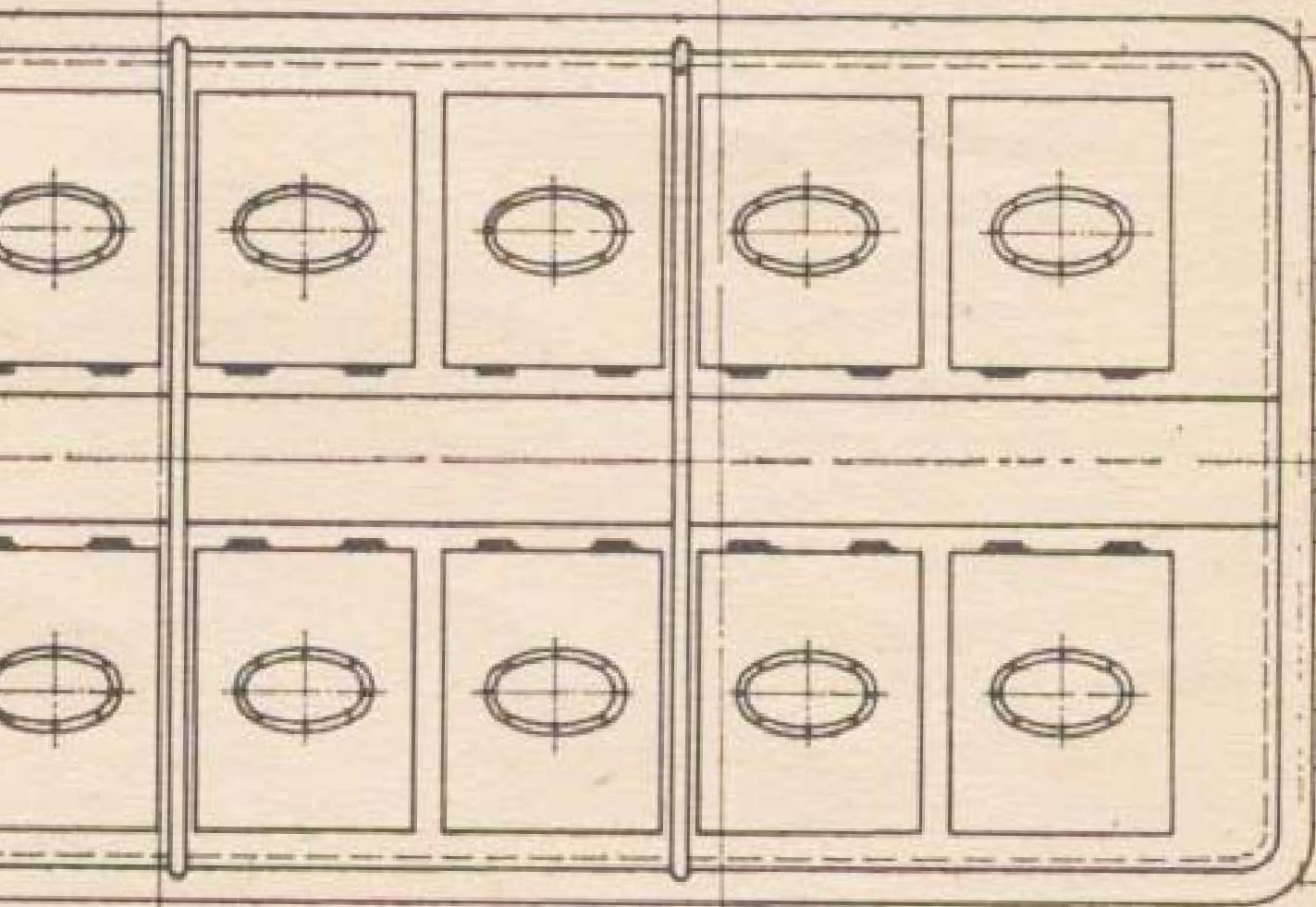

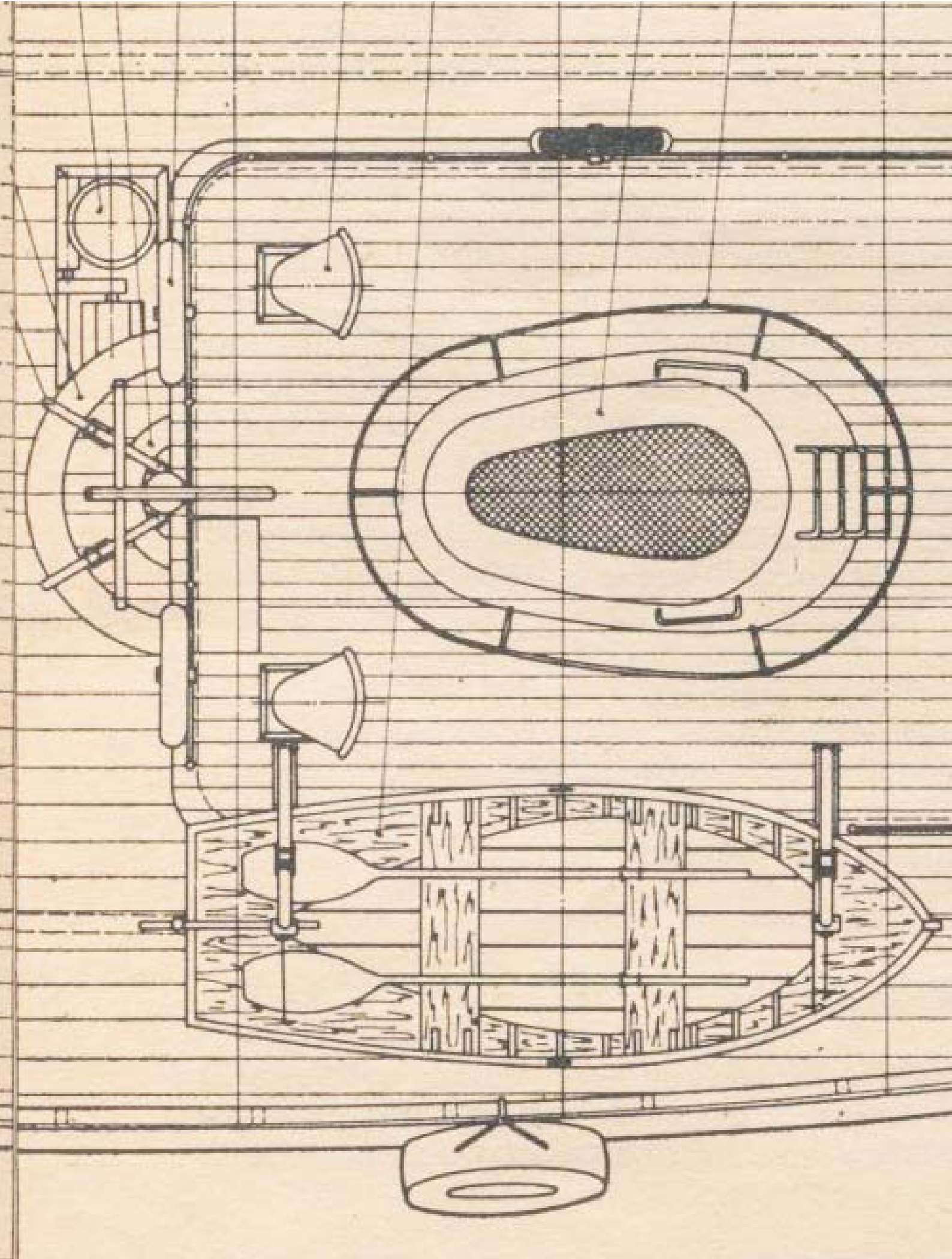

LAF, Jungmannov
Praha 1, CSSR, be

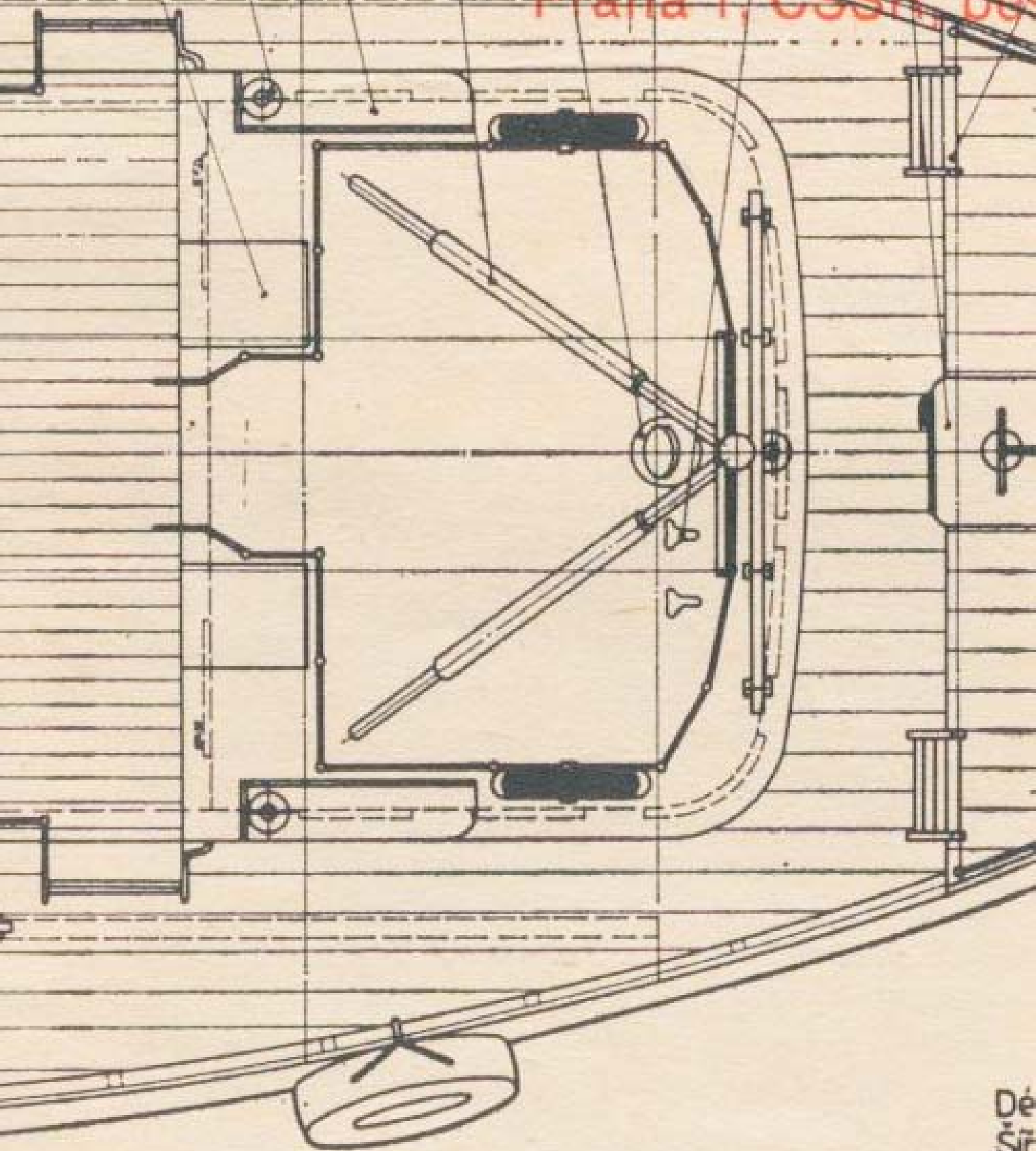

Kresleno na 3 listech

JSK

Dé
Št
Po
Mě

va 24, 110 00
stellen.

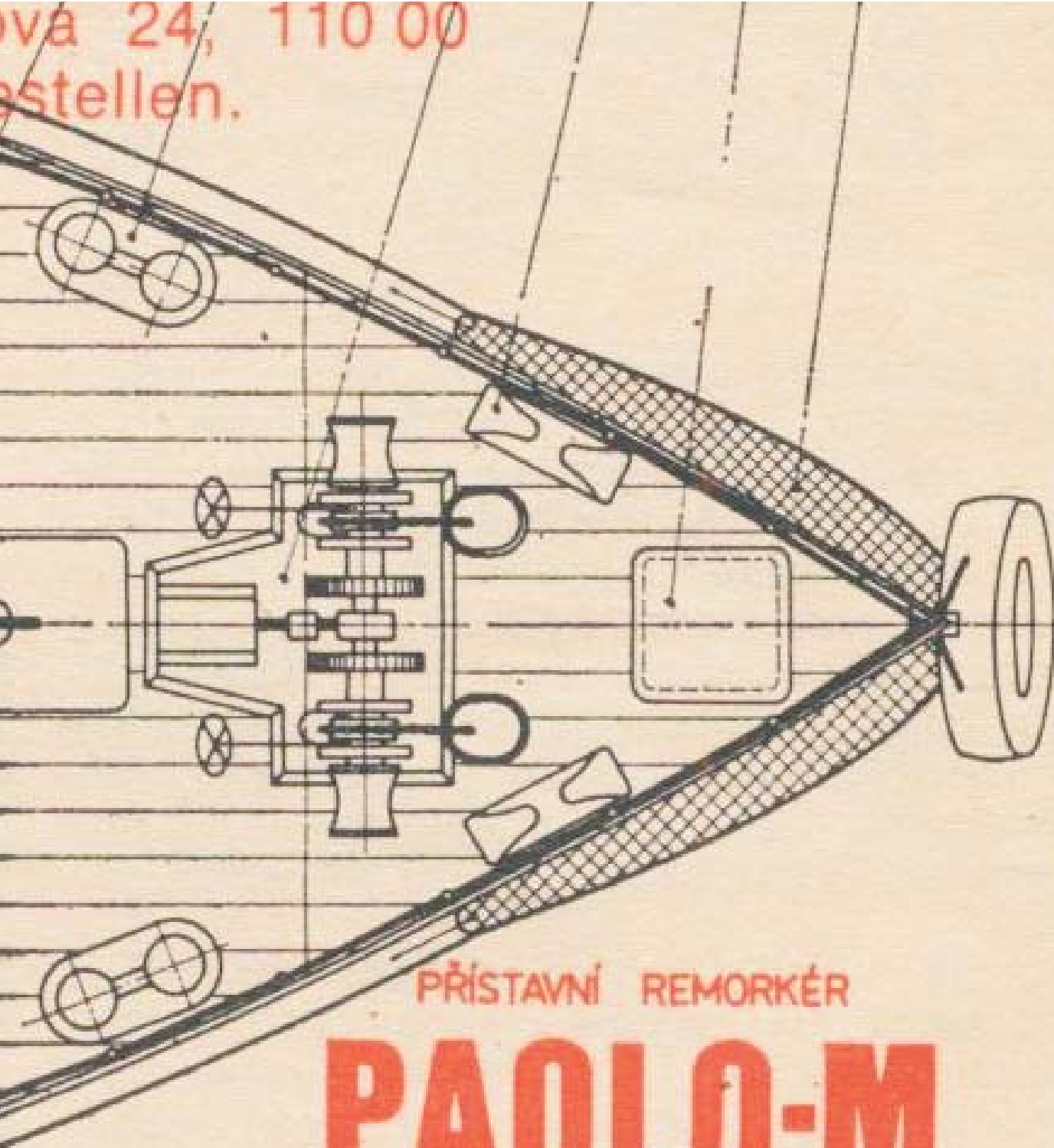

PŘÍSTAVNÍ REMORKÉR

PAOLO-M

Konstrukce: Z.Hladký, J.Staněk
Kreslil: J.Staněk - Praha

Délka lodě
Šířka
Ponor
Měřítko

28,65m
7,15m
4,5m
1:25

Délka modelu
Šířka
Ponor
Hmotnost

1,146m
0,280m
0,140m
16+20kg